

Nortronics/world leader in magnetic tape heads



MASTER FILE OF CATALOGUED TAPE HEADS

### Experience and Imagination

More than 150 combined years of engineering experience, a heavy research budget, and a stimulating environment for imagination are important elements in Nortronics' efforts to design and build better tape heads.

Nortronics' innovations which are now standard throughout the industry include use of the hyperbolic tape head face to eliminate pressure pads, laminated cores, and quartz-deposited gaps for popular priced tape heads; all-metal-face heads; 8-track stereo tape heads for automobiles; "no-mount" snap-in heads; quick-kit mounting adapters; terminal plugs with standard pin spacing and centering; 3-leg "Z combo" stereo record-play-erase heads in a single case; cassette heads which reverse without flip-over; and many more.

### Unequaled Research and Manufacturing Facilities

The new 40,000 square foot Nortronics building was designed to provide control of dust, noise, humidity and temperature. Equipment, from the research laboratory's binocular Unitron metallurgical microscope with Xenon light source, to the production line's 10-7 Torr vacuum quartz gap depositors, is the best available, much of it designed and built at Nortronics, to accommodate new departures in product design requiring equally dramatic departures in manufacturing technique.

### Quality control

Between incoming inspection and use tests just before packaging, each head undergoes an average of 30 inspections, and is subjected to an average of seven different microscopic, visual, and electrical tests. Mechanically, the two half sections of a Nortronics head must be precision lapped to flatness tolerances of one-quarter wave length of monochromatic helium light. Electrically, completed heads are checked for inductance, impedance, DC resistance, long and short wave length response, record and biasing parameters, interchannel and adjacent channel cross-talk, shorts, opens and proper grounding.

**Nortronics**  
COMPANY, INC.

8101 Tenth Avenue North • Minneapolis, Minnesota 55427 • Phone: (612) 545-0401  
CABLE ADDRESS: NORINC TELEEX NO. 29-0304





## Complete Range of Mechanical Configurations and Electrical Specifications

The following pages indicate the enormous variety of head styles and sizes catalogued by and available from Electronics. This is the industry's most complete and comprehensive grouping of types, functions, sizes etc. Our catalogued line includes two, four, eight full track units; multi-channel, stereo, mono; inductances of 50, 100, 200, 400 and 800 mhy; Standard, Premium, and Professional performance criteria; base mount, side mount, rear mount, and no mount; Stereo, Record, Record/Playback, and R/P/E.

## Value Analysis and Heads For Special Requirements

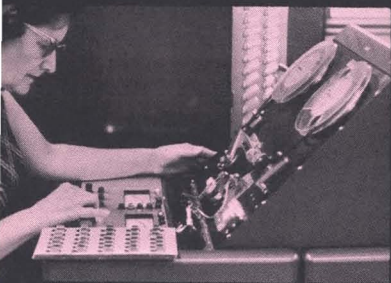
Our Marketing Engineering department will assist you in determining the head best suited to your application. It is easy to over-specify, particularly on tape heads for many instrumentation applications. We can frequently demonstrate how a slight modification in the circuitry will permit enormous reductions in the cost of the tape heads. If your requirements cannot be met by our catalogued line, our engineers will evaluate your problems and will develop special designs to satisfy your needs.



*"The future of magnetic recording... and magnetic heads depends  not so much on what we can do, as on what we can think of doing."*

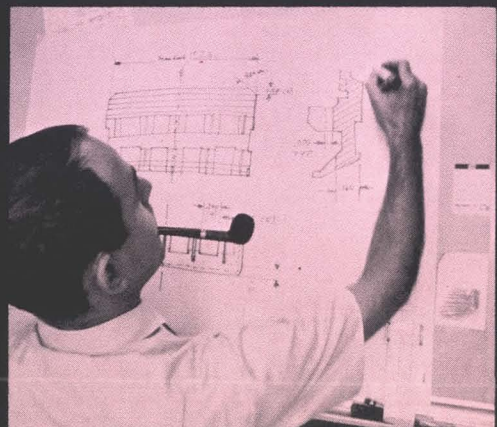
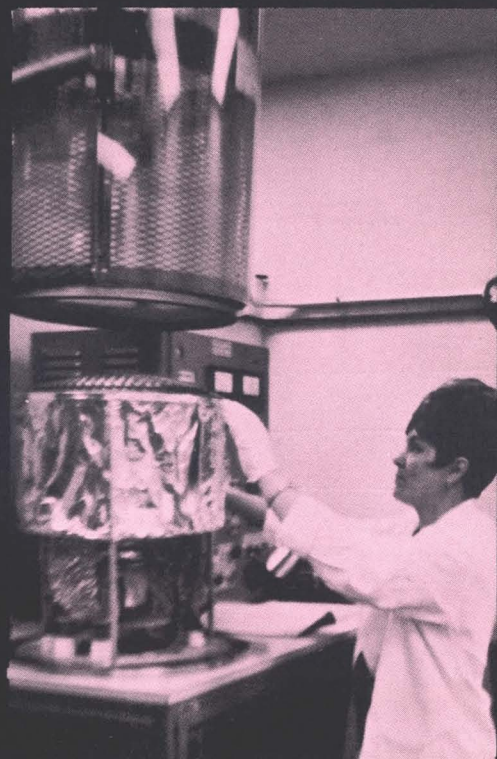



# HOW TO SPECIFY

Selecting the proper tape head for your application can be accomplished by referring to the information below. Technical data on all Nortronics tape heads listed in the following index is contained on the individual pages referenced.

In determining the part number for your application, please refer to the step-by-step selection guide below. Please note that on most items listed in specification charts, Basic part numbers are shown. The guide below can be referred to for exact head characteristics.

1	2	3	4	5	6	7	8
<b>DESIGNATE SERIES</b> P=Premium series XP=Extended tip-premium PR or WP=Professional series (Standard Has No Prefix)	<b>DESIGNATE CASE STYLE</b> List proper letter designation from case outline dwgs on each page	<b>NUMBER OF CHANNELS</b> 1=mono 2=stereo 3=3 channel 4=4 channel	<b>NUMBER OF TRACKS</b> H=2 track (half track) Q=4 track (quarter track) L=8 track	<b>TRACK LOCATION</b> (mono heads only) NONE=Standard stereo offset C=Centered track Y=.020 off center (GIHY) .040 off center (BIHY)	<b>ERASE ELECTRICAL CODE</b> (combo heads only) List code from specification chart	<b>R/P ELECTRICAL CODE</b> List code from specification chart	<b>MOUNTING STYLE</b> List proper mounting shown on individual
<b>EXAMPLE:</b>							
P	A	1	Q	C	4	6K-S	
series	case style	channels	tracks	track location	case code	electrical code	mounting

**PREMIUM SERIES:**

"A" case style; 1 channel (mono); 4 track; centered track; combination erase - R/P head; No. 4 erase electrical code; No. 6K R/P electrical code; side mount with erase section to the left.



# NORTRONICS PRODUCT LOCATOR

## INSTRUMENTATION & COMPUTER HEADS

Mini-digital heads described on Pages 6-7.  
Consult Nortronics Marketing Engineering Department of technical information and product literature on other instrumentation and computer heads.

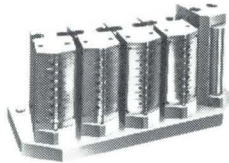

- Custom built to your specifications
- Digital and analog designs, IRIG and IBM formats
- Read, write, and erase heads
- Available with adjustable mount, fixed precision ground base, and as complete assemblies

Head assembly pictured illustrates two seven channel read heads and two seven channel write heads which interlace to provide fourteen channels on one inch tape. Full track ferrite core erase head completes the head configuration precision aligned on machined base plate.

## STUDIO SERIES HEADS

Page 8



- Uncompromised excellence for use with two-inch, one-inch or half-inch tape
- For professional audio and mastering recorders
- Standard SMPTE formats

## CASSETTE HEADS

Page 9

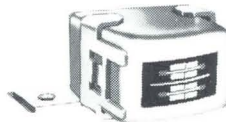

- Units for mono, stereo, and language lab track configurations
- Unique bi-directional design permits record-play-erase in both directions without flipover

## MINIATURE HEADS

Page 10



- Flush face for use with tape
- Relieved face for drum, disc, and film stripe applications

## NARROW TRACK HEADS

Pages 12 and 16

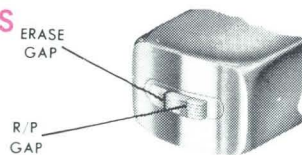

- Ideal for dictation machines, card readers, film stripe
- Close-coupled gaps for simplified circuitry, accurate editing
- Extended tip or flush face

## PROFESSIONAL SERIES HEADS

Page 11

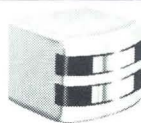

- Unexcelled response from 20 Hz to 20 KHz
- Designed for maximum head life
- Full track and two track models for 1/4" tape

## HEADS FOR 1/4" TAPE

8 TRACK .....	13
3, 4 TRACK .....	14, 15
2 TRACK .....	16, 17
FULL TRACK .....	12



- Heads for recording, duplicating, and computer instrumentation applications
- All track and channel configurations
- New concepts in Stereo Z Combo, with R/P/E functions in a single stereo head

## Z-COMBO HEADS

Pages 6, 7, 11, 13  
Bias application notes page 7



- Erase, record and playback functions in the same core structure
- Stereo, mono and special purpose units
- Very close spacing of erase and R/P gaps

## NORTRONICS ACCESSORIES

Pages 18-19



- Bias Oscillator Transformers
- Cartridge and Universal Mounting Brackets
- Plugs, Clips, and Cable Assemblies
- Contactor Heads, Guide Posts, etc.

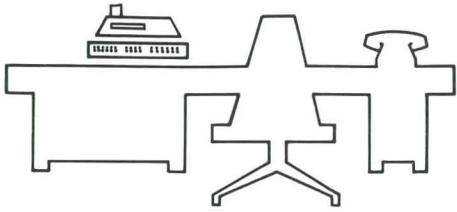

# NORTRONICS MINI-DIGITAL HEADS



*The growing need of industry for complex information fast has led to the development of a wide range of new electronic calculators, input/output systems, terminal systems, and other peripheral equipment, designed to bring the speed and selected capabilities of a computer to any desk top. A wide range of digital functions are now being performed by such mini-computer equipment.*

All specifications and read/write data are based on tests using 3M 870 tape.



MODEL NUMBER	PR-B1F8R B 7487	P-B2H8R C 5387	P-B2H8K C 5383	P-B2Q8R C 1387	P-BQQN8R B 3187	P-BQL8R B 3587	W2R8N B 1884 ZW2RK38N* B 1438	W4J8N B 2484
Tape Width (Inches)	.250	.250	.250	.250	.250	.250	.150	.150
Number of Tracks on Tape	1	2	2	4	4	8	2	4
Number of Channels in Head	1	2	2	2	4	4	2	4
Track Width (Inches)	.250	.080	.080	.042	.037	.020	.056	.021
Channel Spacing (Center to Center-Inches)	—	.160	.160	.136	.071	.0635	.088	.035
Gap Spacer	0.5 Mil	0.5 Mil	0.1 Mil	0.5 Mil	0.5 Mil	0.5 Mil	0.2 Mil	0.2 Mil
Inductance, 1 KHZ	10 Mhy	10 Mhy	20 Mhy	10 Mhy	85 Mhy	10 Mhy	10 Mhy	10 Mhy
Resistance, D.C. (Ohms)	10	28	25	32	290	70	39	68
Saturation Current—ma. to Produce 90% Peak Output @ 200 BPI (Measured Zero to Peak, Alternate Polarity)	4.8 ma.	2.7	2.1	2.1	0.9	2.6	2.7	2.8
Write Current—ma. 150% Saturation Current @ 200 BPI	7.2	4.0	3.2	3.1	1.4	3.9	4.0	4.2
Read Output—mv. P-P (Open Circuit)								
NRZI @ 200 BPI								
3.75 ips.	11.2	6.5	6.3	4.6	11.8	2.3	4.2	2
15 ips.	40	24	21	17	44	8.5	15	7.4
Read Output—mv. P-P 800 BPI Ref. 200 BPI.	85% min	85% min	85% min	85% min	85% min	85% min	85% min	85% min

\*Preliminary data—consult Nortronics Marketing Engineering Department for production specifications.



# Z-COMBO ERASE-R/P HEADS

PATENT PENDING

Nortronics Z-Combo heads offer erase plus record and playback functions in the same core structure, permitting very close spacing of erase and r/p gaps. High-frequency bias for the recording section is obtained automatically by internal magnetic leakage, so no external coupling is required between erase and record coils.

## BIAS APPLICATION NOTES:

Bias control is required as usual to set the effective record bias flux to a value which gives "peak" or optimum recording sensitivity for a 1 kHz signal. Since it is not practical to vary the internal bias coupling of the head, the bias must be controlled by changing the erase coil driving voltage.

Recommended method for bias adjustment is to vary the D.C. supply voltage to the high frequency oscillator. Since the oscillator operates "class C," its output voltage will be directly proportional to the D.C. supply voltage.

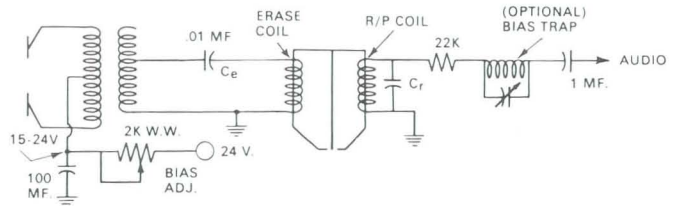

A wire wound potentiometer is placed in series with the D.C. line, as shown, to adjust the voltage. Typical sizes for this control may range from 1K to 5K, depending upon the oscillator current drain.

Adjustment of bias is best made while recording a 1 kHz signal with the record head and at the same time monitoring the playback signal with a separate, temporarily-installed, monitor head. Azimuth alignment between record and monitor heads is not important.

The actual erase voltage required for peak bias is also a function of the effective capacitor,  $C_r$ , across the coil of the r/p section, this capacitance consisting of the internal head shunt capacitance plus cable capacitance plus any additional shunt capacitor. The capacitor  $C_r$  and the audio driving circuit give a resultant source impedance at the bias frequency as seen by the record coil which has considerable effect upon head bias sensitivity.

With a high source Impedance ( $C_r$  less than 100 pf.) a higher erase voltage will be required for peak bias.

With a low source Impedance, ( $C_r$  greater than 200 pf.) a lowered erase voltage for peak bias will result. A difference of as much as two to one in erase voltage can sometimes be obtained.

Erasure is a function of the voltage applied to the erase head, so that a more complete erasure of the tape will be obtained at the higher voltage required when  $C_r$  is at a minimum. However, this may cause difficulty if the oscillator cannot supply the greater power, or the head may tend to overheat. If adequate erasure can be obtained at the lower erase voltage which will be achieved with the 200 pf. or greater  $C_r$ , this will be preferable.

Erase voltage may also be controlled by varying the coupling capacitor  $C_e$ . Bias current may be varied by tuning the bias trap provided  $C_r$  is at minimum.

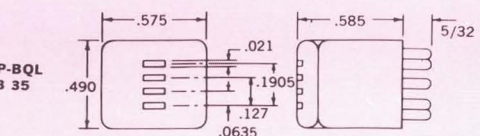
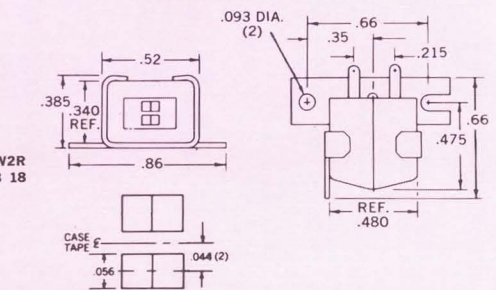
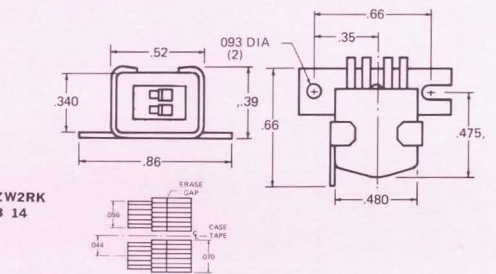
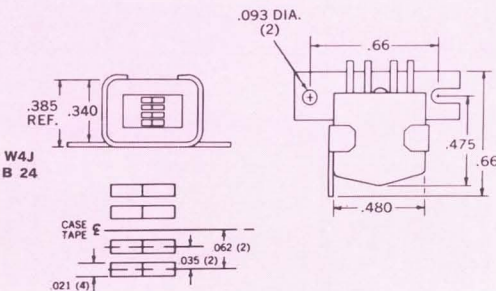
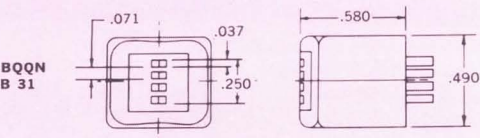
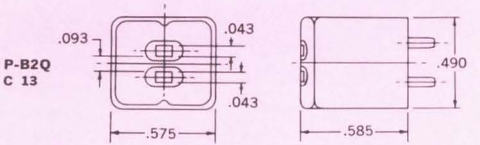
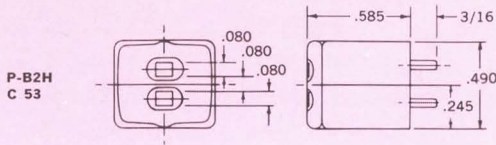
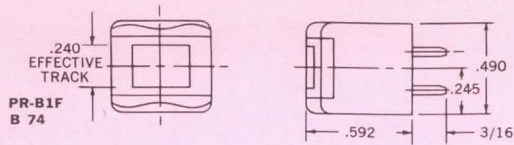



## STUDIO SERIES HEADS for 1/2", 1" and 2" tape



STR-4B

STR-8B

STR-16B

### DESIGNED ESPECIALLY ...

for professional audio or mastering recorders using one half, one, or two inch tape. Uncompromised quality dictates only the finest in design, materials and technology. Custom built to your electrical specifications and mechanical mounting requirements, the Studio Series is available in standard SMPTE track formats; 3 or 4 channels on one half inch tape, 8 or 12 channels on one inch tape, or 16 channels on two inch tape. Record and Playback heads feature ultra thin HY MU 800 laminated precision-lapped cores for minimum eddy current loss, deposited silicon monoxide gaps for maximum frequency definition and hyperbolic face contour for uniform intimate tape contact. Compatible companion erase heads are available with selective (independent) channels or full width, Ferrite core structures reduce ultra high frequency bias losses while providing erasure to virgin tape level.

### SPECIFICATIONS

TAPE WIDTH	BASIC MODEL NUMBER			
	ERASE	RECORD	PLAYBACK	
ONE HALF INCH TAPE	STE- 3B6 STE- 4B6	STR- 3B7 STR- 4B7	STP- 3B3 STP- 4B3	STP- 3B8 STP- 4B8
ONE INCH TAPE	STE- 8B6 STE-12B6	STR- 8B7 STR-12B7	STP- 8B3 STP-12B3	STP- 8B8 STP-12B8
TWO INCH TAPE	STE-16B6	STR-16B7	STP-16B3	STP-16B8
Inductance, 1 KHZ	215 UHY	4.0 MHY	300 MHY	650 MHY
Resistance, D.C. (OHMS)	1.3	8.3	245	530
Track Width (Inches)	.080	.070	.070	.070
Track Spacing (Inches)	.130	.130	.130	.130
Gap Width (Microinches)	—	500	100	200
AVERAGE RECORD/PLAYBACK CHARACTERISTICS, USING 3M 201 TAPE, BIASED FOR PEAK 1 KHZ OUTPUT AT A LEVEL OF 12 DB BELOW TAPE SATURATION @ 1 KHZ				
Erase Voltage @ 100 KHZ	11 Volts	—	—	—
Erase Current @ 100 KHZ	100 MA	—	—	—
Bias Voltage @ 180 KHZ @ 15 IPS	—	17 Volts	—	—
Bias Voltage @ 180 KHZ @ 7.5 IPS	—	16 Volts	—	—
Bias Current @ 180 KHZ @ 15 IPS	—	8.0 MA	—	—
Bias Current @ 180 KHZ @ 7.5 IPS	—	7.5 MA	—	—
Audio Record Current @ 15 IPS	—	.40 MA	—	—
Audio Record Current @ 7.5 IPS	—	.38 MA	—	—
1 KHZ OUTPUT (15 IPS)	—	—	2.1 MV	3.2 MV
1 KHZ OUTPUT (7.5 IPS)	—	—	1.9 MV	3.0 MV
10 KHZ/1 KHZ Output (15 IPS)	—	—	+11 DB	+10 DB
10 KHZ/1 KHZ Output (7.5 IPS)	—	—	+5 DB	+3 DB
15 KHZ/10 KHZ Output (15 IPS)	—	—	+1 DB	-1.5 DB
15 KHZ/10 KHZ Output (7.5 IPS)	—	—	-1 DB	-4 DB

Specifications subject to change without notice.

### PHYSICAL CHARACTERISTICS

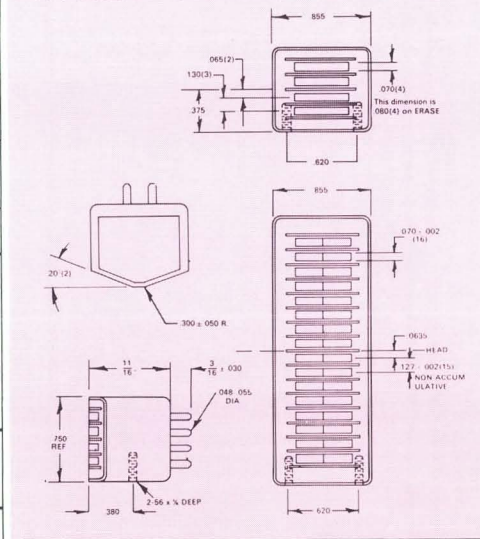

Typical Mounting Base Illustrated.

Other Mount Styles Available.

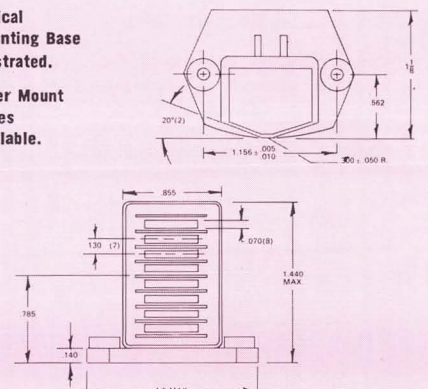





# TAPE HEADS

## Cassette Type

Nortronics features a complete line of heads for the cassette system, including a new bi-directional design that permits automatic changing, since the cassette need not be flipped over to play the second half of the tape.\*

The Nortronics bi-directional design puts all three functions on one head, permitting two capstans to be used, thus providing for automatic reversing. Nortronics also produces conventional compatible cassette heads.

Typical operating speed for commercial applications is 1.875 ips.

Designed to provide usable frequency response from 50-12,000 Hz at 1.875 ips. with an excellent signal-to-noise ratio.

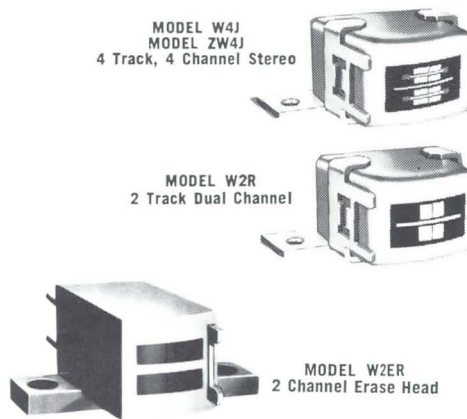

### TRACK CONFIGURATIONS

The track configurations of the cassette system have been defined on an international basis. The following configurations are available:

- Model W1R**  
2 Track Monaural Record/Playback
- Model ZW1R**  
2 Track Monaural Erase/Record/Playback
- Model W2R**  
2 Track, Dual Channel Record/Playback
- Model W2J**  
4 Track, 2 Channel Stereo Record/Playback
- Model ZW2J**  
4 Track, 2 Channel Stereo Erase/Record/Playback
- Model W4J**  
4 Track 4 Channel Stereo Record/Playback
- Model W4J**  
4 Track, 4 Channel Stereo Erase/Record/Playback
- Model W2ER**  
2 Channel Erase Head

### ELECTRICAL SPECIFICATIONS

MODEL NUMBER		W1R6F W2R6F	ZW1R36K ZW2R36K	W4J8N W2J8N	W1R8N W2R8N	ZW4J34F ZW2J34F	W4J4F W2J4F	W2ER
FUNCTION		R/P	E/R/P	R	R	E/R/P	P	E
R/P	Track Width (Inches)	.056	.056	.021	.056	.021	.021	.070
	Inductance (MHY) @ 100 MV-1 KHz	200	100	10	20	50	80	—
	Resistance, DC (OHMS)	270	200	60	50	140	150	—
R/P	Interchannel Crosstalk @ 1 KHz Rejection (DB)	—	—	—	—	1-2/3-4	30 DB	—
	Gap (Micro Inches)	50	50	50	50	2-3	50 DB	—
ERASE	Induction (MHY) @ 100 MV, 1 KHz	—	1.5	—	—	2	—	2
	Resistance DC (OHMS)	—	30	—	—	38	—	12
	Erasure From Sat. 400 Hz (DB)	—	50	—	—	50	—	60
Average constant-current unequalized R/P characteristics using 3M 272 tape. Biased for peak 1 KHz output at level 10-12 DB below tape saturation. Tape speed, 1.875 inches per second								
ERASE	Bias Voltage @ 60 KHz (Volts Rms)	20	25*	3.5	7.0	30*	—	13
	Bias Current @ 60 KHz (Ma Rms)	33	70*	1.6	1.5	60*	—	17
	Record Current (MA)	.028	.070	.130	1.40	.070	—	—
	1 KHz Playback Output (MV)	.4	.4	—	—	.15	.17	—
5 KHz Output Vs. 1 KHz Output (DB)		-1	-8	—	—	-14	—	—
10 KHz Output Vs. 1 KHz Output (DB)		—	—	—	—	—	-14	—

\* R/P section normally receives sufficient bias thru magnetic leakage from the erase section, 50 pf across R/P coil during record.

### PHYSICAL CHARACTERISTICS

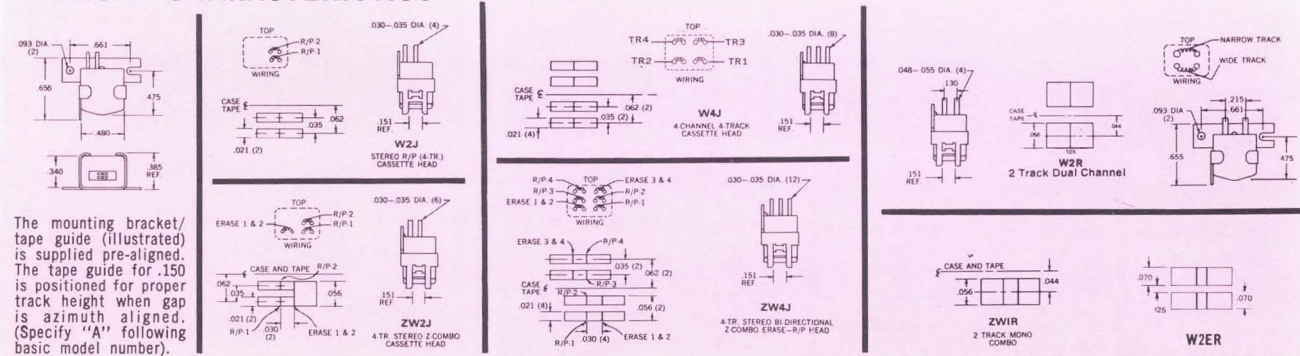

The mounting bracket/tape guide (illustrated) is supplied pre-aligned. The tape guide for .150 is positioned for proper track height when gap is azimuth aligned. (Specify "A" following basic model number).

### TYPICAL APPLICATIONS

#### ENTERTAINMENT

For monaural applications; one or two recorded tracks, .059 inches wide separated by a guard band of .030 inches on the standard .150 inch tape. For compatible stereophonic recording; four recorded tracks, each .023 inches wide, are grouped in identical adjacent pairs with .012 guard bands — permits playing monaural and stereo tapes on the same equipment without loss of program material. Despite close spacing, crosstalk rejection of stereo models is in excess of 36 db.

#### LANGUAGE LABORATORY-DUPLICATORS

Model W2R provides two 56-mil tracks for language lab applications with master on one channel and student record/playback on other. Also used for cue and audio information in pre-programmed slide projectors, for duplicating mono cassettes, and for recording audio and synchronization tracks with portable motion picture cameras.

## TAPE HEADS miniature types

### SIZES

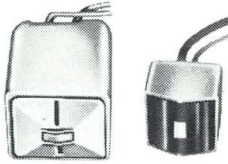

#### "L" SERIES

( $\frac{5}{16}$ "W x  $\frac{3}{16}$ "H x  $\frac{3}{8}$ "D)

#### "M" SERIES

( $\frac{1}{4}$ "W x  $\frac{1}{4}$ "H x  $\frac{1}{4}$ "D)

**"M" SERIES** — Features small size —  $\frac{1}{4}$  inch cubed. R/P track widths are .045 or .070 with compatible erase track widths of .055 or .090 inch. Face contour is either flush (as illustrated) or relieved. Standard relief for 16 mm stripe is .050 inch notch across top of face from case to core. To specify a relieved face add the number "3" to part number shown below. Available as no mount or base, side or rear mount (No. 2-56 stud).

**"L" SERIES** — Incorporates laminated cores, deposited quartz gaps and either a flush face for use with tape or a relieved face (as illustrated)

for use in drum, disc or film stripe applications. The flush face contour is hyperbolic, while the pole-tip projection is .010 to .020 inch on relieved heads. To specify a relieved face add the number "5" to part number shown below. Available as no mount or base or rear mount (No. 2-56 stud). Special track widths or specifications on custom order basis. Six-inch leads std.

**TYPICAL APPLICATIONS** — Magnetic drums and discs, magnetic stripes on motion picture film and miniature tape recorders. When used with magnetic drums, discs and film stripes, it is recommended that a projecting track version be selected.

### TYPICAL SPECIFICATIONS

#### TYPICAL MINIATURE RECORD/PLAY HEADS

MODEL NUMBER	L42R8L	L24R2K	L24R8L	L12R8K	M70R4L
TYPE OF HEAD	Record/Playback	Record/Playback	Record/Playback	Record/Playback	Record/Playback
Inductance, 1 KC	80 MHY	200 MHY	40 MHY	30 MHY	20 MHY
Impedance, 1 KC	500 $\Omega$	1.2 K	250 $\Omega$	200 $\Omega$	130 $\Omega$
Resistance, D.C.	128 $\Omega$	400 $\Omega$	125 $\Omega$	125 $\Omega$	80 $\Omega$
Gap Spacer	0.16 MIL	0.10 MIL	0.16 MIL	0.10 MIL	0.16 MIL
Track Width	.042 INCH	.024 INCH	.024 INCH	.012 INCH	.070 INCH
Average 7.5 IPS constant current Record/Playback characteristics using 3M190 tape at 1 KC and recorded 12 DB below tape saturation at 1 KC.					
Peak Bias, 60 KC	.070 MA	0.33 MA	0.65 MA	0.75 MA	2.0 MA
Record Current	60 UA	30 UA	50 UA	60 UA	100 UA
1 KC Output	1.0 MV	1.0 MV	0.45 MV	0.25 MV	0.6 MV
10 KC/1 KC Ratio	0 DB	+2 DB	0 DB	0 DB	-8 DB

#### MINIATURE ERASE HEADS

NORTRONICS MODEL NUMBER	L42E6U	M90E3U
Track Width	.042 INCH	.090 INCH
Inductance, 1 KC	5 MHY	16 MHY
Resistance, D.C.	38 $\Omega$	315 $\Omega$
†Erase Current Oper.	28-42 MA	12 MA
Impedance, 60 KC	1.2 K	4 K
Voltage, 60 KC RMS	32-48 VOLTS	50 VOLTS

† For 56 DB Erasure of Saturated Tape.

Specifications subject to change without notice.

### STANDARD MOUNTS

Variations of the mountings shown can be furnished — write for details.

#### "M" HEADS

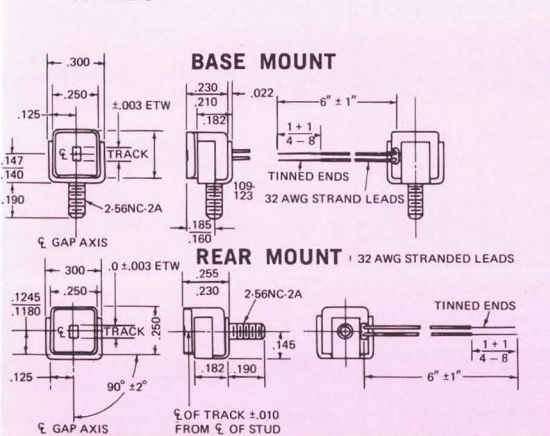

#### "L" HEADS

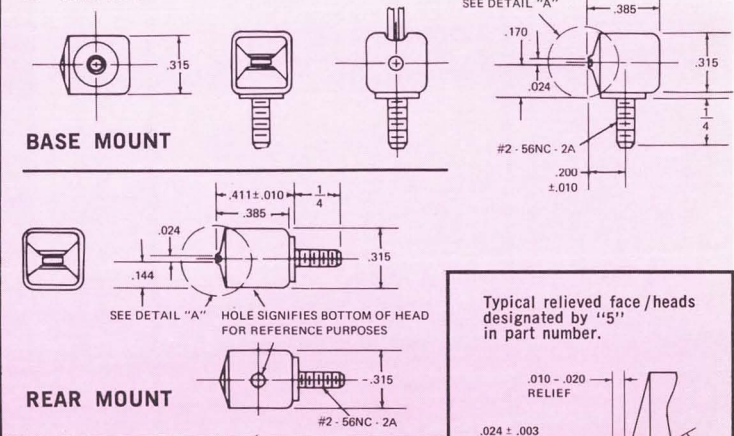

### PHYSICAL CHARACTERISTICS

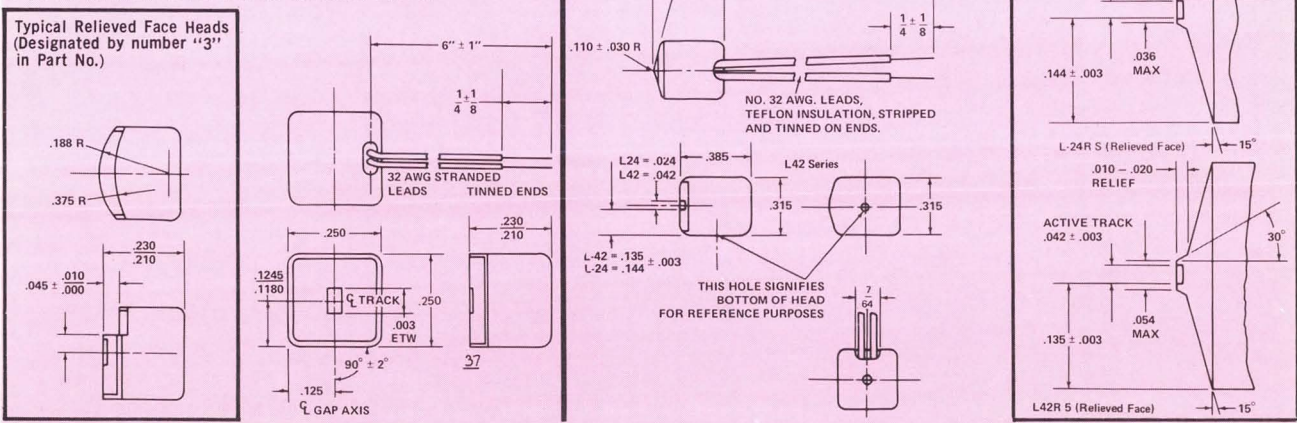



## TAPE HEADS

Narrow track/Video recorder/Extended pole piece

Extended tip or flush face — Mu Metal or Alfenol Cores  
Standard track widths: .0135 inches, .020 inches,

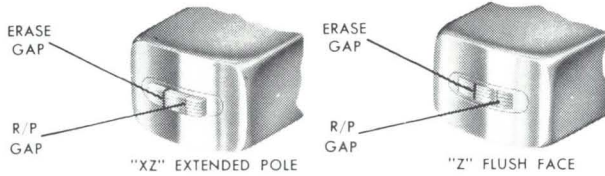

### SPECIFICATIONS

BASIC MODEL NO.	X-ZRINC	X-ZRILC	CILC RILC	ZRILC	XACILC
Track Width (Inches)	.0135	.020	.020	.020	.020
Electrical Code	75 K	96 K	7 K	47 K	13 K
Head Function	Erase—R/P	Erase—R/P	R/P	Erase—R/P	R/P
R/P Inductance	500 MHY	220 MHY	400 MHY	450 MHY	170 MHY
R/P Gap Spacer	0.1 MIL	0.1 MIL	0.1 MIL	0.1 MIL	0.1 MIL
Erase Inductance	0.3 MHY	8 MHY	—	14 MHY	—
Erase Current (Bias)	65 MA	15 MA	—	12 MA	—
Erase Voltage (Bias)	2.5 V	28 V	—	32 V	—
Record Current	35 UA	30 UA	—	22 UA	—
1 KHZ Output	0.8 MV	0.5 MV	0.8 MV	0.7 MV	0.4 MV
10 KHZ/1 KHZ Ratio	-12 DB	-12 DB	-12 DB	-15 DB	-12 DB

Typical 3.75 IPS constant current R/P characteristic using 3M190 tape. Peak biased at 60 KHZ at 1 KC and recorded 12 DB below tape saturation.

**\*Z Combo — Type Z** — Combination erase and R/P head places all three functions within a single head. Ideal for dictation machines, card readers and film stripe applications. "Close-coupled" gap provides internal bias coupling that simplifies required circuitry and permits accurate editing.

**Type XZ** offers additional advantage of extended pole tip (.010-.020 inches) for gap to oxide contact on hard or non-compliant surfaces.

**\*R/P Heads — Type X** — Extended pole tip R/P heads feature high sensitivity mu-metal cores.

**Type XA** — Extended pole tip R/P heads feature long wearing alfenol cores.

### PHYSICAL CHARACTERISTICS

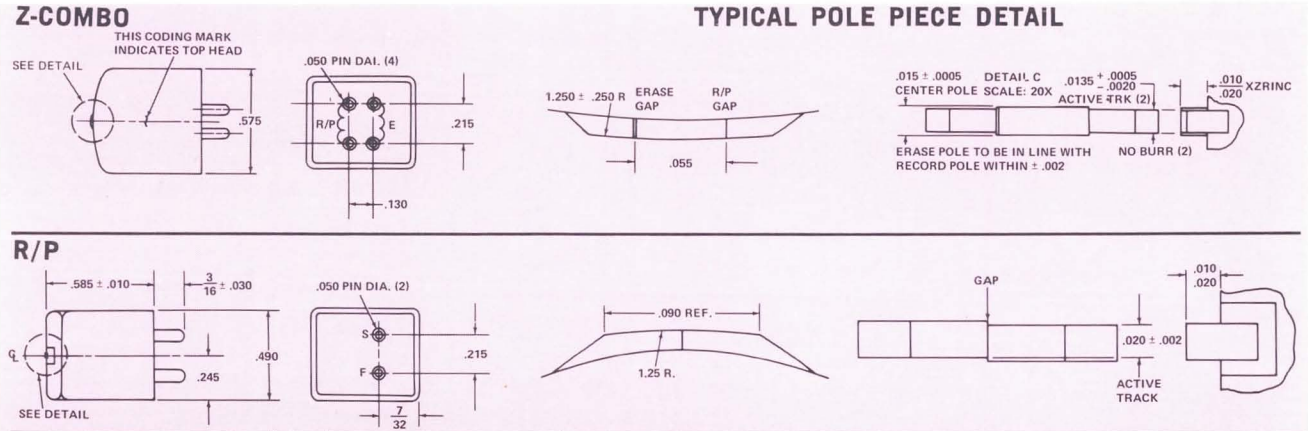

### SPECIAL Z COMBO HEADS

Features include

- Special wide cases give full-width tape support
- In-line gaps permit precise timing accuracy
- Z combo close-spaced erase gap controls editing and alignment
- Provides maximum center tape area for video information



Check with Nortronics for your special-purpose head requirements.

### AUDIO & SYNC FOR VIDEO RECORDERS

Custom built to your specifications, this series of special Z combo & R/P heads is designed specifically for video recorders. Two or three channels of sound and/or sync information can be recorded along the edges of one-half or one-inch tape.

### ERASE HEADS FOR 1" TAPE

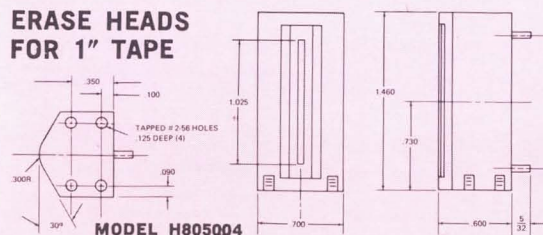

### ERASE HEADS FOR 1/2" TAPE

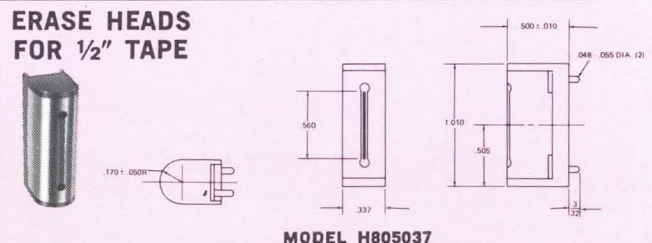

## TAPE HEADS

full-track heads for 1/4" tape

TRACK SYSTEM	FULL TRACK			
	PR-B1F			
BASIC MODEL NUMBER	4R	11R	7K	12N
ELECTRICAL CODE				
HEAD FUNCTION	Record Only	Record Only	Playback	Playback
TYPE OF CIRCUIT	Tubes/Transistors	Tubes/Transistors	Tubes/Transistors	Tubes/Transistors
Inductance, 1 KHz	55 MHY	4.0 MHY	400 MHY	650 MHY
Impedance, 1 KHz	330 Ω	27 Ω	2.5 K	4 K
Max. Bias Frequency	250 KHz	500 KHz	—	—
Resistance, D.C.	125 Ω	3.35 Ω	220 Ω	275 Ω
Gap Spacer	0.5 MIL	0.5 MIL	0.1 MIL	0.2 MIL
Average 7.5 IPS Constant Current Record/Playback Characteristics Using 3M 201 Tape, Peak Biased at 1 KHz and Recorded 12 DB Below Tape Saturation.				
Peak Bias Current, 60 KHz	.95 MA	9.0 MA	—	—
Bias Voltage RMS, 60 KHz	43 V	25 V	—	—
Record Record Current	.15 MA	.540 MA	—	—
1 KHz Output	—	—	3.5 MV	5.0 MV
10 KHz/1 KHz Ratio	—	—	+3DB	+3 DB

Specifications subject to change without notice.



PR-B1F

### PR SERIES

- Sets a new standard for high performance magnetic heads.
- Unexcelled response from 20HZ to 20KHZ.

Professional series full track — PR-B1F, designed especially for long wave length response with extra wide pick-up poles, smooth response characteristics are obtained to below 20HZ. Fine precision lapped laminated core stacks and deposited gaps extend short wavelength response. Extra deep deposited quartz gap.

Companion PR-B1EF ERASE also available.

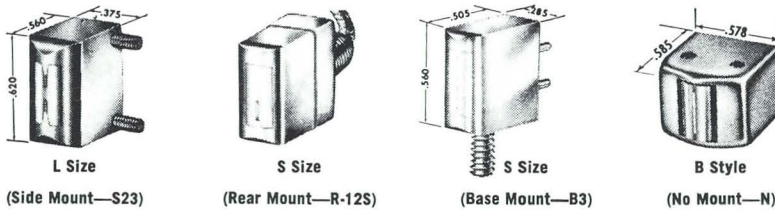

ALL NORTRONICS erase heads have efficient double-gap construction plus metal faces and cases for superior tape contact surface and heat transfer. MEF and B1EF types have same metal core construction and will erase over 60 DB. at operating frequencies up to 100 KHZ. Case sizes shown at left are "L"—large for side mount, "S"—small for base and rear mount, and "B"—standard r/p size.

PR-B1EF "PRO" series erase heads have super-efficient hybrid ferrite/laminated core structures which give erase depth in excess of 70 DB. and operate at frequencies up to 200 KHZ. Available in B-style only, with standard mounting options.

Erase heads are shown with various mounts, but all are available in your choice of base, side, rear or no mount.

TRACK SYSTEM	FULL TRACK			
	MEF-B1EF		PR-B1EF	
BASIC MODEL NUMBER	1	4	14	4
ELECTRICAL CODE				
Inductance, 1 KHz	40 MHY	4.0 MHY	.200 MHY	1.2 MHY
Resistance, D.C.	88 Ω	20 Ω	1.8 Ω	3.8 Ω
†Erase Current Oper.	13 MA	40 MA	120 MA	95 MA
Impedance, 60 KHz	12 K	1 K	80 Ω	42 Ω
Voltage, 60 KC RMS	120 V	40 V	9.3 V	40 V

Specifications subject to change without notice. †For 56 DB erasure of Saturated Tape.

To determine erase model number, select a basic model number, add the erase electrical code, add a dash (—) and add mounting designator (below). Following are typical examples:

MEF1-S23U, Full-track mono erase head, No. 1 erase electrical code, "L case," side mount, track up (studs are to left).  
Erase Mounting Designator follows model number in this fashion:

"MEF1-N0", no mount (S Size)

"L-N0", no mount (L Size)

"B3", standard base mount (Supplied S Size only).

For mono heads, add a U for up or D for down after the B3 to denote track up or track down.

"S23", standard side mount (Supplied L Size only).

For mono heads, add a U for up or a D for down after S23 to denote track up or track down.

"R-12S", standard rear mount and 12 inch shielded leads (Supplied S Size only).

"R-4U", standard rear mount and 4 inch unshielded leads (Supplied S Size only).

For "B" style erase heads, mounts are the same as for R/P heads.

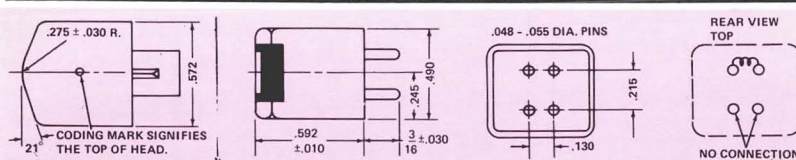

### CASE OUTLINE STYLES

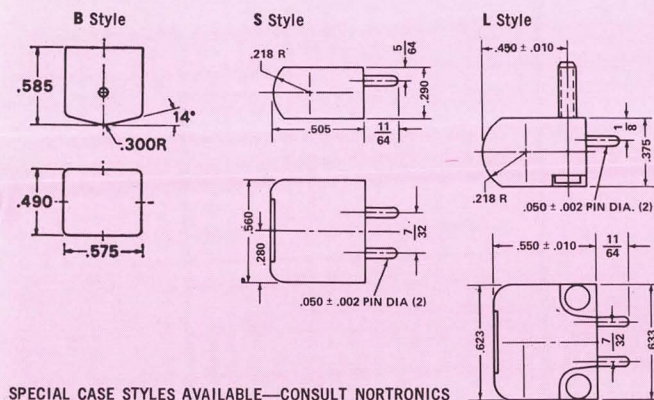

SPECIAL CASE STYLES AVAILABLE—CONSULT NORTRONICS

### MOUNT

#### SIDE MOUNT (—S)

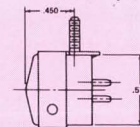

L or R Combo erase on left or right side  
U or D Mono track up or down

#### BASE MOUNT (—B)

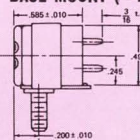

L or R Combo erase on left or right side  
U or D Mono track up or down

#### REAR MOUNT (—R-4U)

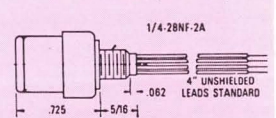

#### REAR MOUNT (—R-12S)

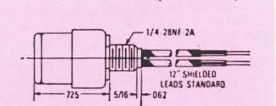



## TAPE HEADS

### 8-track heads for 1/4" tape

#### MODEL ZJ2L Z-Combo

The type ZJ2L offers combination erase and record/playback functions in one head for 8-track stereo applications. Its patented unique "Z-Combo" construction places the erase and R/P gaps only .030 apart in the same pole structure, resulting in extremely accurate height alignment and tracking. Recording and erasing for the 8-track stereo system thereby become fully practicable. Standard B-size case fits most mountings.

#### Advantages of Z-Combo Close-Coupled Gaps

- Intimate tape contact with single or no pressure pad
- Insures overlap alignment of erase when R/P section is azimuth aligned
- Prevents adjacent channel erasure in close spaced track configurations when R/P section is azimuth aligned

8-Track  
4-Channel  
P-BQL-N  
(No Mount)



8-Tr. Stereo Z-Combo  
ZJ2L  
(No Mount)

8-Tr. Stereo  
B2L-N  
(No Mount)



#### MODEL P-BQL

SUITABLE FOR HIGH SPEED DUPLICATORS, LOW SPEED LOGGING APPLICATIONS, AND GENERAL PURPOSE RECORDING AND PLAYBACK.

The NORTRONICS Premium Quality P-BQL four-channel magnetic tape head utilizes the most advanced design and manufacturing techniques. Fine-laminated cores and precision-deposited gaps give extended frequency response capability. Ideal as high speed slave heads for duplication of 8-track stereo at speeds up to 8X or 16X, with bias frequencies up to 750 KHz.

#### MODEL B2L-N

Standard playback—only or record/playback head for automobile or home type Stereo—8 tape cartridge players. Premium version of above head is available with extra-fine laminated cores for improved high frequency response to 15 KHz at 3.75 ips tape speed. Also available Alfenol Premium record-only head for heavy-duty high speed duplicating applications. Give five times normal life.

BASIC MODEL NUMBER	8-TRACK (.021 INCH WIDTH) P-BQL				8-TRACK STEREO ZJ2L	8-TRACK (.020 INCH TRACK WIDTH) STEREO B2L			8 TRACK STEREO Special Duplicating
	2 HEADS INTERLACE FOR 8 TRACKS ON 1/4" TAPE					47 K	8R	4R	
ELECTRICAL CODE	8R	4R	4K	6K	47 K	8R	4R	7K	AP-B2L14R
HEAD FUNCTION	Duplicating Record	Record Only	Record/ Playback	Record/ Playback	Erase/ Record/ Playback	Duplicating Record	Record Only	Record/ Playback	Record Only
TYPE OF CIRCUIT	Tubes/ Transistors	Tubes/ Transistors	Transistors	Tubes/ Transistors	R/P Section Data	Tubes/ Transistors	Tubes/ Transistors	Tubes/ Transistors	Alfenol/ Duplicating
Inductance, 1 KC	10 MHY	50 MHY	100 MHY	200 MHY	400 MHY	10 MHY	50 MHY	400 MHY	2 MHY
Impedance, 1 KC	65 Ω	300 Ω	650 Ω	1.5 K	2.5 K	75 Ω	400 Ω	2.5 K	—
Maximum Bias Frequency	500 KC	200 KC	100 KC	100 KC	100 KC	750 KC	250 KC	100 KC	—
Resistance, D.C. Mono	—	—	—	—	—	20 Ω	100 Ω	520 Ω	10 Ω
Resistance, D.C. Stereo	60 Ω	250 Ω	250 Ω	500 Ω	680 Ω	42 Ω	220 Ω	700 Ω	—
Gap Spacer	0.5 MIL	0.5 MIL	0.1 MIL	0.1 MIL	0.1 MIL	0.5 MIL	0.5 MIL	0.1 MIL	500 U-IN
Track Spacing	.0635 INCH	.0635 INCH	.0635 INCH	.0635 INCH	.127 INCH	.127 INCH	.127 INCH	.127 INCH	—
1 KC Crosstalk Rej.	50 DB	50 DB	50 DB	50 DB	50 DB	50 DB	50 DB	50 DB	—
For "WP" AND PREMIUM — Average 7.5 IPS Constant Current Record/Playback Characteristics Using 3M190 Tape (3M111 Within 5%) Peak Biased at 1 KC and Recorded 12 DB Below Tape Saturation.									
Peak Bias Current, 60 KC	1.8 MA	0.7 MA	0.55 MA	0.35 MA	*15 MA	1.1 MA	0.5 MA	0.15 MA	40 MA @ 30 IPS
Bias Voltage RMS, 60 KC	5 VOLTS	15 VOLTS	15 VOLTS	22 VOLTS	*45 VOLTS	2.6 VOLTS	8 VOLTS	21 VOLTS	30 VOLTS @ 500 KHz
Record Current	140 UA	55 UA	45 UA	35 UA	30 UA	88 UA	40 UA	19 UA	0.3 MA
1 KC Output	—	—	0.6 MV	0.8 MV	0.9 MV	—	—	1.0 MV	—
10 KC/1 KC Ratio	—	—	0 DB	0 DB	-3 DB	—	—	0 DB	—
For "WP" AND PREMIUM — Average 3.75 IPS Constant Current Record/Playback Characteristics Using 3M190 Tape (3M111 Within 5%) Peak Biased at 1 KC and Recorded 12 DB Below Tape Saturation.									
Peak Bias Current, 60 KC	1.5 MA	0.6 MA	0.50 MA	0.30 MA	*10 MA	1.0 MA	0.4 MA	0.12 MA	6 MA
Bias Voltage RMS, 60 KC	4.5 VOLTS	10 VOLTS	13 VOLTS	20 VOLTS	*40 VOLTS	2.3 VOLTS	7 VOLTS	18 VOLTS	3 VOLTS
Record Current	120 UA	45 UA	40 UA	32 UA	20 UA	86 UA	35 UA	35 UA	0.3 MA
1 KC Output	—	—	0.5 MV	0.6 MV	0.8 MV	—	—	0.8 MV	—
10 KC/1 KC Ratio	—	—	-12 DB	-12 DB	-12 DB	—	—	-9 DB	—
For STANDARD HEADS — Average 7.5 IPS Constant Current Record/Playback Characteristics Using 3M190 Tape (3M111 Within 5%) Peak Biased at 1 KC and Recorded 12 DB Below Tape Saturation.									
Peak Bias Current, 60 KC	Not Available				Z-J2L			.55 MA	
Bias Voltage RMS, 60 KC	in				ERASE SECTION DATA			32 VOLTS	
Record Current	Standard Series				Inductance @ 60 KC 12 MHY			30 UA	
1 KC Output	Standard Series				Erasure @ 60 KC 50 DB			0.9 MV	
10 KC/1 KC Ratio	Standard Series				Standard Series			-4 DB	

\* Provides internal bias coupling from erase to R/P section. Bias data above is fed to erase section.

## PHYSICAL CHARACTERISTICS

#### P-BQL

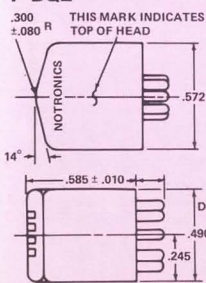

#### ZJ2L

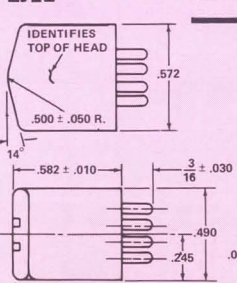

#### B2L

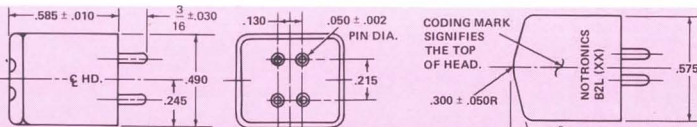

#### REAR MOUNT B2L

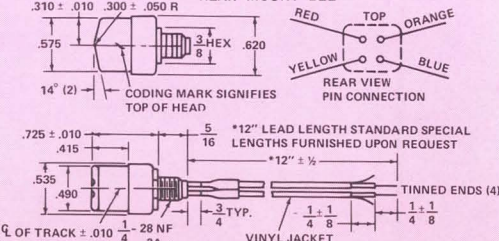



## TAPE HEADS

### 3 and 4-track heads for 1/4" tape

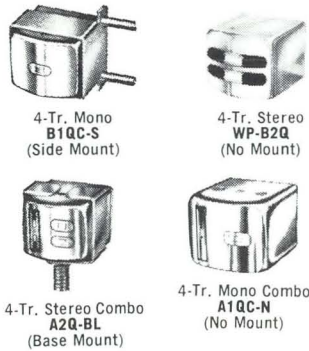

The B2Q, C2Q, G2Q heads shown represent a broad new series of 4-track stereo and monophonic record/playback heads. Each type of head is available in either a PREMIUM or STANDARD version. The PREMIUM series is a fully professional line of tape heads giving unsurpassed performance for broadcast and studio applications. Long life and extended high frequency response at slower tape speeds, are among the benefits of the features listed:

- Fine laminated, precision-lapped, low loss core structures
- Deposited quartz gaps, as fine as 50 micro-inches
- Hyperbolic face contour
- Highly polished all-metal faces
- Compatible mechanically and electrically with older model Nortronics heads
- Superbly shielded against external magnetic fields. The STANDARD versions are recommended for less critical applications where cost is a primary factor. They offer improved high frequency performance over that of conventional solid-core heads, plus the added features of hyperbolic all-metal face and precision deposited quartz gaps.

The P-A2Q, A2Q, P-A1QC and A1QC 4-track series of NORTRONICS Combination Magnetic Tape Heads contain record/playback and erase sections in one miniature case. Internal construction is based on the low-loss, laminated core design. PREMIUM Series P-A2Q and P-A1QC heads offer fully professional fine-laminated core construction where the ultimate in high frequency performance is required. STANDARD A2Q and A1QC series heads are recommended for less critical applications where cost is a primary factor. STANDARD type heads have laminated cores, providing a superior high frequency response over that of conventional solid-core heads. Deposited quartz gaps as fine as 50 micro-inches. Precision-polished metal faces for freedom from oxide buildup. Hyperbolic face contours, available on PREMIUM models, for optimum tape-to-gap contact without need for pressure pads.



#### P-B3Q SERIES

Premium series three channel R/P heads designed especially to meet N.A.B. (USA) track configuration for stereo cartridge machines, two channels for stereo program plus control channel. Precision gap co-linearity eliminates phase cancellation distortion of stereo signal, all metal face insures maximum shielding. B case to fit all mounting accessories.

TRACK SYSTEM BASIC MODEL NUMBER	4-TRACK (.043 INCH TRACK WIDTH)							3-TRACK (.043 INCH WIDTH)			
	MONO — B1QY, B1QC, A1QC							P-B3Q			
ELECTRICAL CODE	(For Premium Series Add "P" Prefix to Above Numbers)							3 CHANNELS FOR 1/4" TAPE			
	8R	4R	8K	4K	6K	7K	7F	2K	4R	6K	7K
HEAD FUNCTION	Duplicating Record	Record Only	Record/Playback	Record/Playback	Record/Playback	Record/Playback	Playback Only	Record/Playback	Record Only	Record/Playback	Record/Playback
TYPE OF CIRCUIT	Tubes/Transistors	Tubes/Transistors	Transistors	Transistors	Transistors	Tubes/Transistors	Tubes/Transistors	Tubes/Transistors	Tubes/Transistors	Transistors	Tubes/Transistors
Inductance, 1 KC	10 MHY	50 MHY	20 MHY	100 MHY	200 MHY	400 MHY	500 MHY	800 MHY	50 MHY	200 MHY	340 MHY
Impedance, 1 KC	70 Ω	400 Ω	150 Ω	650 Ω	1.3 K	2.5 K	3.3 K	5 K	400 Ω	1.3 K	2.0 K
Maximum Bias Frequency	500 KC	250 KC	250 KC	140 KC	120 KC	100 KC	100 KC	80 KC	250 KC	120 KC	100 KC
*Resistance, D.C.	22 Ω	90 Ω	22 Ω	90 Ω	110 Ω	210 Ω	210 Ω	520 Ω	260 Ω	450 Ω	800 Ω
**Resistance, D.C.	32 Ω	90 Ω	32 Ω	90 Ω	200 Ω	390 Ω	390 Ω	700 Ω			
Gap Spacer	0.5 MIL	0.5 MIL	0.1 MIL	0.1 MIL	0.1 MIL	0.1 MIL	0.05 MIL	0.1 MIL	0.5 MIL	0.1 MIL	0.1 MIL
**Track Spacing	.136 INCH	.136 INCH	.136 INCH	.136 MIL	.136 MIL	.136 MIL	.136 INCH	.136 INCH	.100 INCH	.100 INCH	.100 INCH
1 KC Crosstalk Rej.	55 DB	55 DB	55 DB	55 DB	55 DB	55 DB	55 DB	55 DB	55 DB	55 DB	55 DB
For "WP" AND PREMIUM — Average 7.5 IPS Constant Current Record/Playback Characteristics Using 3M190 Tape (3M111 Within 5%) Peak Biased at 1 KC and Recorded 12 DB Below Tape Saturation.											
Peak Bias Current, 60 KC	1.3 MA	0.65 MA	1.6 MA	0.70 MA	0.40 MA	0.25 MA	0.25 MA	0.16 MA	0.65 MA	0.40 MA	0.25 MA
Bias Voltage RMS, 60 KC	3 V	7.5 V	6 V	18 V	25 V	35 V	50 V	45 V	1.5 V	20 V	35 V
Record Current	140 UA	60 UA	150 UA	70 UA	50 UA	35 UA	30 UA	25 UA	60 UA	50 UA	35 UA
1 KC Output	—	—	0.5 MV	0.9 MV	1.3 MV	1.8 MV	1.8 MV	2.6 MV	—	1.3 MV	1.8 MV
10 KC/1 KC Ratio	—	—	0 DB	0 DB	+1 DB	+1 DB	+2 DB	+1 DB	—	+1 DB	+1 DB
For "WP" AND PREMIUM — Average 3.75 IPS Constant Current Record/Playback Characteristics Using 3M190 Tape (3M111 Within 5%) Peak Biased at 1 KC and Recorded 12 DB Below Tape Saturation.											
Peak Bias Current, 60 KC	1.2 MA	0.50 MA	1.25 MA	0.50 MA	0.32 MA	0.20 MA	0.20 MA	0.12 MA	0.50 MA	0.32 MA	0.20 MA
Bias Voltage RMS, 60 KC	2.5 V	7.0 V	5 V	13 V	20 V	25 V	35 V	35 V	7.0 V	15 V	25 V
Record Output	130 UA	50 UA	130 UA	50 UA	44 UA	30 UA	25 UA	22 UA	.50 UA	44 UA	30 UA
1 KC Output	—	—	0.4 MV	0.7 MV	1.0 MV	1.4 MV	1.4 MV	2.1 MV	—	1.0 MV	1.4 MV
10 KC/1 KC Ratio	—	—	-10 DB	-10 DB	-9 DB	-9 DB	-9 DB	-9 DB	—	-9 DB	-9 DB
For STANDARD HEADS — Average 7.5 IPS Constant Current Record/Playback Characteristics Using 3M190 Tape (3M111 Within 5%) Peak Biased at 1 KC and Recorded 12 DB Below Tape Saturation.											
Peak Bias Current, 60 KC	Not Available		1.1 MA	0.70 MA	0.42 MA	Not		0.30 MA			
Bias Voltage RMS, 60 KC	in		20 V	25 V	35 V	Available		45 V			
Record Current	Standard Series		70 UA	50 UA	35 UA	in		25 UA	Not Available		
1 KC Output	Standard Series		0.8 MV	1.2 MV	1.6 MV	Standard		2.4 MV	in		
10 KC/1 KC Ratio	Standard Series		-4 DB	-3 DB	-3 DB	Series		-3 DB	Standard Series		

\* Mono \*\* Stereo

#### CASE OUTLINE STYLES

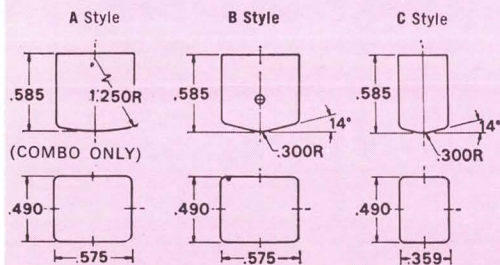

SPECIAL CASE STYLES AVAILABLE—CONSULT NORTRONICS

#### PBQQ & BQQN

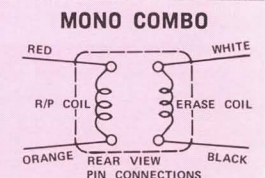
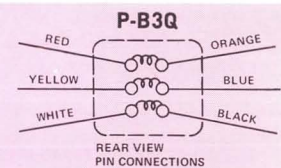
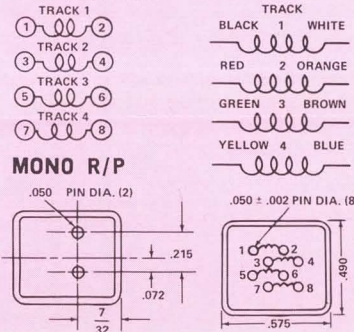



## TAPE HEADS

### 4-track heads for 1/4" tape

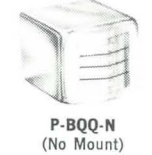

Nortronics Model P-BQQ is an instrument quality, 4-channel in-line record/reproduce magnetic tape head for 1/4-inch tape. Its fine laminated-core construction is designed for professional applications with the ultimate in high frequency performance. Deposited quartz gaps as fine as 50 micro-inches result in exceptionally clean "smear-free" gap edges. The all-metal face greatly reduces oxide loading problems and the hyperbolic contour promotes intimate tape-to-gap contact allowing reduced tape tension and elimination of pressure pads.

**Typical Applications** — Instrumentation recording including carrier modulated types such as AM, FM or Pulse, as well as straight digital and analog recording. Tracks of the P-BQQ head are compatible with the 4-track stereo system making it ideal for audio duplication, background music and 4-channel in-line stereo.

Two versions are available, offering a choice between the minimum interchannel crosstalk and lower price. The P-BQQ style has the superior interchannel crosstalk rejection of 55 db. For some applications, such as pulse recording, the 18 db crosstalk rejection of the more economical BQQN model may be acceptable.

BASIC MODEL NUMBER	PREMIUM 4-TRACK (.037 INCH WIDTH) P-BQQ 4 CHANNELS FOR 1/4" TAPE			
	23R	4R	4K	7K
ELECTRICAL CODE				
HEAD FUNCTION	Duplicating Record	Record Only	Record/Playback	Record/Playback
TYPE OF CIRCUIT	Tubes/Transistors	Tubes/Transistors	Transistors	Tubes/Transistors
Inductance, 1 KC	12 MHY	50 MHY	100 MHY	400 MHY
Impedance, 1 KC	75 Ω	320 Ω	600 Ω	2.2 K
Maximum Bias Frequency	500 KC	150 KC	100 KC	80 KC
Resistance, D.C.	55 Ω	220 Ω	220 Ω	690 Ω
Gap Spacer	0.5 MIL	0.5 MIL	0.1 MIL	0.1 MIL
Track Spacing	.071 INCH	.071 INCH	.071 INCH	.071 INCH
1 KC Crosstalk Rej.	55 DB	55 DB	55 DB	55 DB

For **PREMIUM** — Average 7.5 IPS Constant Current Record/Playback Characteristics Using 3M190 Tape (3M111 Within 5%) Peak Biased at 1 KC and Recorded 12 DB Below Tape Saturation.

	2.0 MA	0.60 MA	0.70 MA	0.30 MA
Peak Bias Current, 60 KC	2.0 MA	0.60 MA	0.70 MA	0.30 MA
Bias Voltage RMS, 60 KC	4 V	7 V	15 V	30 V
Record Current	110 UA	60 UA	60 UA	34 UA
1 KC Output	—	—	0.7 MV	1.4 MV
10 KC/1 KC Ratio	—	—	0 DB	0 DB

For **PREMIUM** — Average 3.75 IPS Constant Current Record/Playback Characteristics Using 3M190 Tape (3M111 Within 5%) Peak Biased at 1 KC and Recorded 12 DB Below Tape Saturation.

	1.6 MA	0.50 MA	0.50 MA	0.22 MA
Peak Bias Current, 60 KC	1.6 MA	0.50 MA	0.50 MA	0.22 MA
Bias Voltage RMS, 60 KC	3 V	6 V	10 V	25 V
Record Current	90 UA	50 UA	50 UA	30 UA
1 KC Output	—	—	0.5 MV	1.1 MV
10 KC/1 KC Ratio	—	—	-10 DB	-9 DB

## ERASE HEADS

All Nortronics erase heads have efficient double-gap construction plus metal faces and cases for superior heat transfer. They will operate effectively at erase frequencies up thru 100 kc, and also on d.c. Two low-cost standard case sizes, "L" and "S," in the various mounting styles as illustrated to the right and indicated below. All erase models are also available in the B-case style to match the r/p heads; example, B2EQ4-N which is identical electrically to the SEQ4.

Erase heads are shown with various mounts, but all are available in your choice of base, side, rear or no mount.

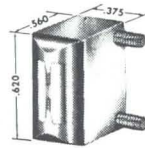

To determine erase model number, select a basic model number, add the erase electrical code, add a dash (—) and add mounting designator (below). Following is a typical example:

SEQ4-R-12S, 4-track (quarter track) stereo erase head, No. 4 erase electrical code, "S" case, rear mount, 12 inch shielded leads.

Erase Mounting Designator follows model number in this fashion:

"SEQ4-N9", no mount (S Size)

"-N", no mount (L Size)

"-B3", standard base mount (Supplied S Size only). For mono heads, add a U for up or D for down after the B3 to denote track up or track down.

"-S23", standard side mount (Supplied L Size only). For mono heads, add a U for up or a D for down after S23 to denote track up or track down.

"-R-12S", standard rear mount and 12 inch shielded leads (Supplied S Size only).

"-R-4U", standard rear mount and 4 inch unshielded leads (Supplied S Size only).

For "B" style erase heads, mounts are the same as for R/P heads.

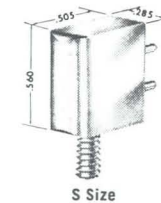
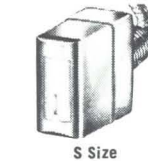

## ERASE HEADS

TRACK SYSTEM	4-TRACK		
	MONO	STEREO	MEQ — SEQ; B2EQ
NORTONICS BASIC MODEL NO.	1	2	4
ELECTRICAL CODE			
Inductance, 1 KC	80 MHY	0.13 MHY	10 MHY
Resistance, D.C.	240 Ω	1.8 Ω	38 Ω
†Erase Cur. Oper.	5 MA	120 MA	13 MA
Impedance, 60 KC	30 K	40 Ω	3 K
Volt., 60 KC RMS	120 V	5 V	40 V

† For 56 DB erasure of Saturated Tape.

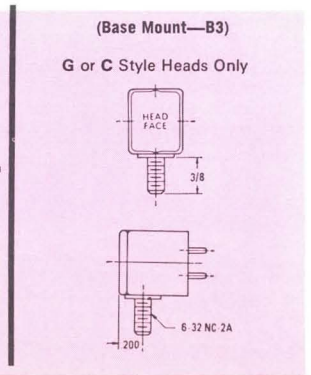
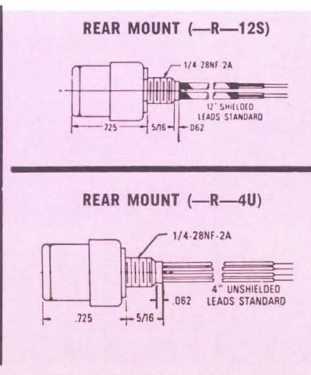
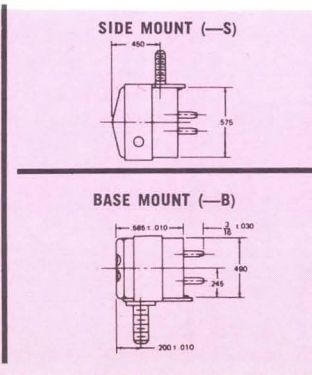
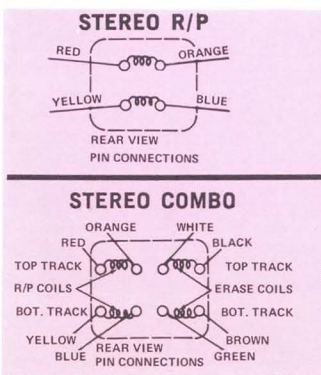

## TAPE HEADS

### 2-track heads for 1/4" tape

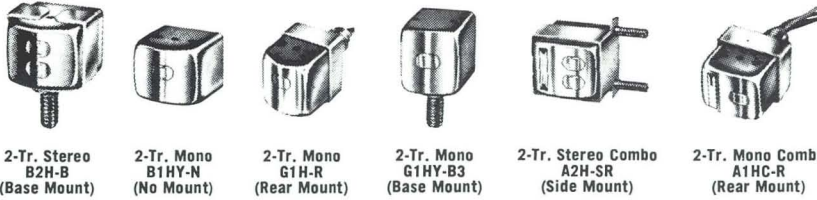

For reel-to-reel and cartridge applications. Hyperbolic all-metal faces for maximum shielding, optimum tape-to-gap contact. Precision deposited quartz gaps, as fine as 50 micro-inches. PREMIUM version offers extra long life, extended frequency response, especially at slower tape speeds.

BASIC MODEL NUMBER	2-TRACK (.080 INCH TRACK WIDTH)								2 Track STEREO Z-J2H
	MONO — B1HY, G1H, G1HY, A1HC STEREO — B2H, A2H (See opposite page for PR-B2H series)								
ELECTRICAL CODE	8R	4R	8K	4K	6K	7K	7F	2K	46K
HEAD FUNCTION	Duplicating Record	Record Only	Record/Playback	Record/Playback	Record/Playback	Record/Playback	Record/Playback	Record/Playback	ERASE
TYPE OF CIRCUIT	Tubes/Transistors	Tubes/Transistors	Transistors	Transistors	Transistors	Tubes/Transistors	Tubes/Transistors	Tubes	R/P Section Data
Inductance, 1 KC	10 MHY	50 MHY	20 MHY	100 MHY	200 MHY	400 MHY	450 MHY	800 MHY	200 MHY
Impedance, 1 KC	72 Ω	320 Ω	150 Ω	650 Ω	1.3 K	2.5 K	3.3 K	5 K	1.3 K
Maximum Bias Frequency	500 KC	200 KC	250 KC	150 KC	100 KC	100 KC	80 KC	60 KC	100 KC
Resistance, D.C. Mono	14 Ω	70 Ω	14 Ω	70 Ω	110 Ω	165 Ω	165 Ω	400 Ω	—
Resistance, D.C. Stereo	27 Ω	130 Ω	27 Ω	130 Ω	245 Ω	410 Ω	410 Ω	720 Ω	260 Ω
Gap Spacer	0.5 MIL	0.5 MIL	0.1 MIL	0.1 MIL	0.1 MIL	0.1 MIL	0.05 MIL	0.1 MIL	0.1 MIL
Track Spacing Stereo	.160 INCH	.160 INCH	.160 INCH	.160 INCH	.160 INCH	.160 INCH	.160 INCH	.160 INCH	.160 INCH
1 KC Crosstalk Rej.	55 DB	55 DB	55 DB	55 DB	55 DB	55 DB	55 DB	55 DB	50 DB

For "WP" AND PREMIUM — Average 7.5 IPS Constant Current Record/Playback Characteristics Using 3M190 Tape (3M111 Within 5%) Peak Biased at 1 KC and Recorded 12 DB Below Tape Saturation.

Peak Bias Current, 60 KC	1.7 MA	0.70 MA	2.0 MA	0.80 MA	0.40 MA	0.33 MA	0.46 MA	0.25 MA	*30 MA
Bias Voltage RMS, 60 KC	3.3 V	9 V	7.5 V	20 V	30 V	40 V	55 V	55 V	*40 V
Record Current	200 UA	75 UA	220 UA	80 UA	60 UA	40 UA	46 UA	30 UA	UA
1 KC Output	—	—	0.7 MV	1.2 MV	1.8 MV	2.4 MV	2.2 MV	3.6 MV	MV
10 KC/1 KC Ratio	—	—	0 DB	0 DB	+1 DB	+1 DB	+2 DB	+1 DB	-3 DB

For "WP" AND PREMIUM — Average 3.75 IPS Constant Current Record/Playback Characteristics Using 3M190 Tape (3M111 Within 5%) Peak Biased at 1 KC and Recorded 12 DB Below Tape Saturation.

Peak Bias Current, 60 KC	1.5 MA	0.60 MA	1.8 MA	0.70 MA	0.30 MA	0.22 MA	0.37 MA	0.20 MA	*80 MA
Bias Voltage RMS, 60 KC	2.8 V	8 V	6.5 V	15 V	25 V	30 V	45 V	40 V	*25 V
Record Current	180 UA	60 UA	200 UA	66 UA	45 UA	30 UA	37 UA	22 UA	46 UA
1 KC Output	—	—	0.6 MV	0.9 MV	1.2 MV	1.8 MV	1.5 MV	2.5 MV	1.2 MV
10 KC/1 KC Ratio	—	—	-10 DB	-10 DB	-9 DB	-9 DB	-7 DB	-9 DB	-12 DB

For Standard Heads — Average 7.5 IPS Constant Current Record/Playback Characteristics Using 3M190 Tape (3M111 Within 5%) Peak Biased at 1 KC and Recorded 12 DB Below Tape Saturation.

Peak Bias Current, 60 KC	—	—	—	1.1 MA	0.80 MA	0.6 MA	—	0.4 MA	ERASE SECTION DATA
Bias Voltage RMS, 60 KC	—	—	—	20 V	30 V	45 V	—	65 V	INDUCTANCE @ 1 KC
Record Current	—	—	—	80 UA	60 UA	40 UA	—	30 UA	0.9 MHY
1 KC Output	—	—	—	1.1 MV	1.7 MV	2.2 MV	—	3.4 MV	ERASURE
10 KC/1 KC Ratio	—	—	—	-4 DB	-3 DB	-3 DB	—	-3 DB	50 DB

\* Provides internal bias coupling from erase to R/P section. Bias data above is fed to erase section.

Specifications Subject to Change Without Notice.

### CASE OUTLINE STYLES

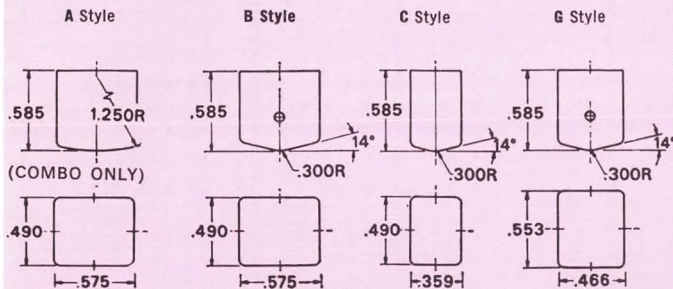

SPECIAL CASE STYLES AVAILABLE—CONSULT NORTRONICS

### NO MOUNT (—N) MONO R/P G CASE

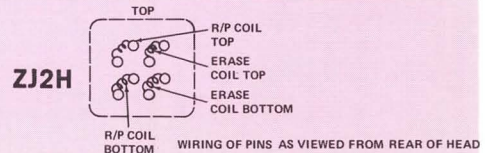
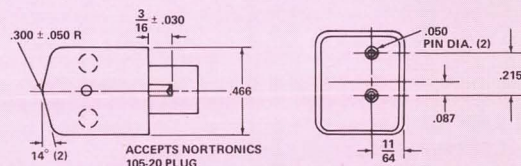



## TAPE HEADS

### 2-track heads for 1/4" tape



BASIC MODEL NUMBER	PROFESSIONAL PR-B2H 2 TRACK (.080 INCH TRACK WIDTH)				
	8R	4R	11R	7K	12L
ELECTRICAL CODE					
HEAD FUNCTION	Record Only	Record Only	Record Only	Record/Playback	Playback
Inductance, 1 KHz	10 MHY	50 MHY	4.5 MHY	400 MHY	700 MHY
Impedance, 1 KHz	68 Ω	320 Ω	33 Ω	2500 Ω	4400 Ω
Resistance, D.C.	24 Ω	130 Ω	15 Ω	410 Ω	570 Ω
Gap Spacer	.5 MIL	.5 MIL	.5 MIL	.1 MIL	.160 MIL
Track Spacing	.160	.160	.160	.160	.160
1 KHz Crosstalk Rej.	55 DB	55 DB	55 DB	55 DB	55 DB

For PROFESSIONAL HEADS — Average 7.5 IPS Constant Current Record/Playback Characteristics Using 3M 201 Tape, Peak Biased at 1 KHz and Recorded 12 DB Below Tape Saturation.

Peak Bias Current, 60 KHz	3.3 MA	0.7 MA	5.8 MA	.33 MA	—
Bias Voltage RMS, 60 KHz	14 V	9 V	18 V	40 V	—
Record Current	.190 MA	.075 MA	.360 MA	.040 MA	—
1 KHz Output	—	—	—	2.4 MV	2.9 MV
10 KHz/1 KHz Ratio	—	—	—	+1 DB	+3 DB

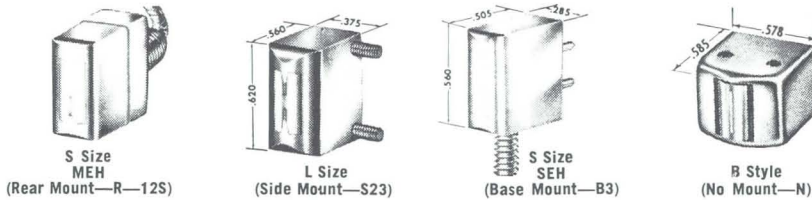

#### PR SERIES

- Sets a new standard for high performance magnetic heads.
  - Unexcelled response from 20 HZ to 20KHZ.
- Professional series R/P heads. Designed especially for long wave length response with extra wide pickup poles, smooth response characteristics are obtained to below 20HZ. Fine precision lapped laminated core stacks and deposited gaps extend short wavelength response. Extra deep deposited quartz gap.

ALL NORTRONICS erase heads have efficient double-gap construction plus metal faces and cases for superior tape contact surface and heat transfer. MEH, SEH and B2EH types have same metal core construction and will erase over 60 DB. at operating frequencies up to 100 KHZ. Case sizes shown at left are "L"—large for side mount, "S"—small for base and rear mount, and "B"—standard r/p size.

PR-B2EH "PRO" series erase heads have superior efficient hybrid ferrite/laminated core structures which give erase depth in excess of 70 DB. and operate at frequencies up to 200 KHZ. Available in B-style only, with standard mounting options.

Erase heads are shown with various mounts, but all are available in your choice of base, side, rear or no mount.

To determine erase model number, select a basic model number, add the erase electrical code, add a dash (—) and add mounting designator (below). Following are typical examples:

MEH1-S23U, 2-track (half track) mono erase head, No. 1 erase electrical code, "L case," side mount, track up (studs are to left).

Erase Mounting Designator follows model number in this fashion:

For "B" style erase heads, mounts are the same as for R/P heads.

"SEH2-N9", no mount (S Size)

"-N", no mount (L Size)

"-B3", standard base mount (Supplied S Size only). For mono heads, add a U for up or D for down after the B3 to denote track up or track down.

"-S23", standard side mount (Supplied L Size only).

For mono heads, add a U for up or a D for down after S23 to denote track up or track down.

"-R-12S", standard rear mount and 12 inch shielded leads (Supplied S Size only).

"-R-4U", standard rear mount and 4 inch unshielded leads (Supplied S Size only).

#### ERASE HEADS

##### TRACK SYSTEM — 2-TRACK

NORTRONICS BASIC MODEL NO.	MONO — MEH STEREO — SEH; B2EH			STEREO — PRB2EH	
	1	2	4	14	4
ELECTRICAL CODE					
Inductance, 1 KC	50 MHY	0.20 MHY	8 MHY	.225 MHY	5.5 MHY
Resistance, D.C.	160 Ω	1.8 Ω	30 Ω	3.6 Ω	30 Ω
†Erase Cur. Oper.	6 MA	120 MA	20 MA	70 MA	17 MA
Impedance, 60 KC	20 K	50 Ω	2 K	85 Ω	2 K
Volt., 60 KC RMS	120 V	6 V	40 V	6 V	34 V

† For 56 DB Erase of Saturated Tape.

#### SIDE MOUNT (—S)

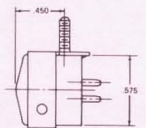

L or R  
Combo erase on left  
or right side  
U or D  
Mono track up or down

#### BASE MOUNT (—B)

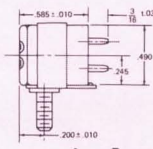

L or R  
Combo erase on left  
or right side  
U or D  
Mono track up or down

#### BASE MOUNT (—B3)

##### G or C Style Heads Only

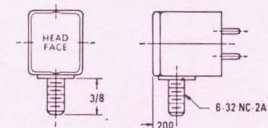

U or D  
Mono track up or down

#### Stereo R/P

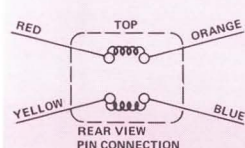

#### Stereo Combo R/P Erase

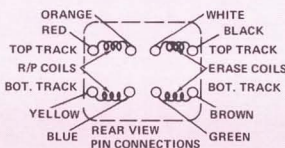

#### Mono Combo

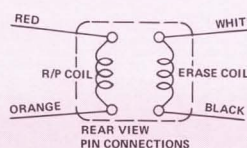

#### REAR MOUNT (—R—12S)

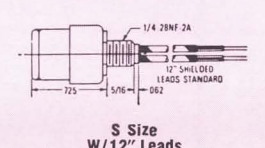

S Size  
W/12" Leads  
(—R—4U) W/4" Leads (unshielded)



# BIAS OSCILLATOR TRANSFORMERS

# NORTRONICS

## TO DRIVE RECORD AND ERASE HEADS

- Heavy-duty Ferrite E-core construction assures minimum external magnetic field.
- High efficiency, high Q, clean waveform, and good voltage regulation.
- Wide frequency and voltage range.
- Output voltage at secondary of transformer may be varied by adjustment of the D.C. power supply voltage to the oscillator.
- Power handling up to 3 watts.

Model Number	Circuit Type and Mount	Application	Typical Operating Frequency (KHz)	Secondary Voltage (RMS)	Compatible Nortronics Heads
T70-T2	Transistor, PC Board	General Purpose	50-120	40, 80, 120	No. 4 & No. 1 Erase
T60-T2	Transistor, Can & Lug	General Purpose	60-110	40, 80, 120	No. 4 & No. 1 Erase
T70-T6	Transistor, PC Board	Duplicating	230-500	70	Drives 10 No. 8R Record
T60-T6	Transistor, Can & Lug	Duplicating	230-500	70	Drives 10 No. 8R Record
T70-T5	Transistor, PC Board	Professional	150-200	—	PR Series Erase
T60-E	Vacuum Tube, Can & Lug	General Purpose	40-70	7 & 120	No. 2 & No. 1 Erase
T60-F	Vacuum Tube, Can & Lug	General Purpose	60-100	60 & 150	No. 4 & No. 1 Erase

Table and circuit list the various methods of operation for the T70-T2 oscillator circuit, to obtain power for Nortronics #4 erase heads, at three different frequencies.

## T-70 SERIES

for printed circuit board circuit

- Pin terminals provide for plug-in and soldering
- Nylon case measures 1 1/4" x 1 1/2" x 1 1/8"
- May be used with standard transistor push-pull or single-ended Class "C" oscillator circuits.

### T70-T2 ERASE OPERATION

Frequency ER. V. RMS	EB D.C. Volts	SEC. Taps	CC MF.
60 KHZ.	20 V.	4 - 5*	.01
40 V.A.C.	15 V.	4 - 5	.002
	10 V.	5 - 6	.01
80 KHZ.	25 V.	4 - 5*	.01
50 V.A.C.	20 V.	4 - 5	.002
	13 V.	5 - 6	.01
100 KHZ.	30 V.	4 - 5*	.0047
60 V.A.C.	25 V.	4 - 5	.002
	18 V.	5 - 6	.0047

\* Preferred

### PARAMETER TABLE

	T70-T2	T70-T5	T70-T6
Pri. Induct. (1-3)	130 UHY.	60 UHY.	18 UHY.
Pri. D.C. Res. (1-3) Ohms	0.35	0.2	0.06
Sec. D.C. Res. (4-6) Ohms	15	0.3	0.22
Turns Ratio (1-3):(4-5)	1:15	1:0.5	—
Turns Ratio (1-3):(5-6)	1:3	1:1	—
Turns Ratio (1-3):(4-6)	1:45	1:15	1:1.67
*Out Volts (4-5)	40 V.	12 V.	—
*Out Volts (5-6)	80 V.	24 V.	—
*Out Volts (4-6)	120 V.	36 V.	50 V.
Tun. Cap. CF (60 KHZ.)	.047	—	—
Tun. Cap. CF (100 KHZ.)	.015	.038	—
Tun. Cap. CF (150 KHZ.)	—	.016	—
Tun. Cap. CF (250 KHZ.)	—	.0047	.033
Tun. Cap. CF (500 KHZ.)	—	—	.0075

\*No Load RMS Oscillator Voltages with 20 Volt D.C. Supply Output Voltage is Directly Proportional to D.C. Supply Voltage at Transformer Center Tap.

## T-60 SERIES for chassis mounting

- Color coded leads, anodized aluminum case (1 1/8" diameter, 1 3/8" high)
- Two 6-32 x 3/8" spade lugs
- Units for transistor and vacuum tube applications

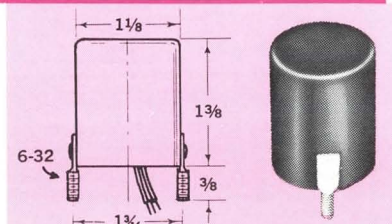

## CONNECTOR PLUG

MODEL 106-20

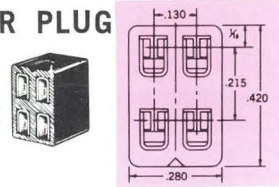

4-Pin Black Phenolic Plugs permit instant connection to all 4 pins of Stereo Heads and 2 pins of Mono Heads. 105-20 plug is for all Nortronics heads except BQQ, P-B3Q and P-BQL.

## PLUG & CABLE ASSEMBLY

MODELS 139-70

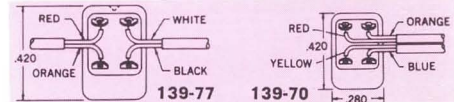

Assemblies ready to plug onto Head Terminal Pins. Consist of proper plug and two shielded cables (nominal length 18" each). 139-70 is used with all Nortronics stereo heads, with cable pairs connected to the upper pair of pins and lower pair of pins. 139-77 is used with Nortronics mono-combo and certain cassette heads, with cable pairs connected to the right pair of pins and left pair of pins.

## PIN CLIPS

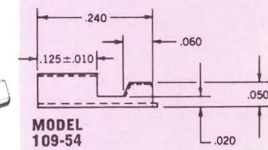

The 109-54 is a gold plated beryllium copper push-on clip formed to fit the terminal pins of all Nortronics heads. Lead wires may be soldered easily to the small end of the clip, leaving the larger end open to push on to the terminal pins. Pin clips permit ready attachment or removal of leads to terminals of heads, and also eliminate damage to head caused by soldering leads directly to pins.

## PIN CLIP & CABLE ASSEMBLIES

139 SERIES

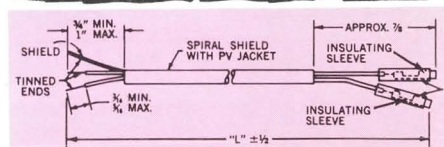

Provided to make neat and simple electrical connections to the terminal pins of Nortronics heads. Two conductor (No. 26) shielded wire insulated with vinyl jacket, with 109-54 pin clips. Available in 2 lengths, 4 color combinations:

	9 inch	24-inch
Red-Orange	139-55	139-78
Yellow-Blue	139-56	139-79
White-Black	139-57	139-80
Green-Brown	139-58	139-81



# ACCESSORIES

## CONTACTOR HEAD

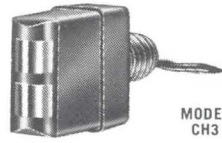
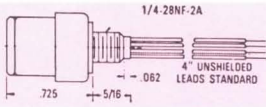

MODEL CH3

Use with metal-foil cueing to operate relay. Has two isolated contactor shoes. Model CH3-R-4U has rear mount and 4" leads. Model CH3-N9 is no-mount small-case size. CH3-B3 is base mount.

## TAPE GUIDE POST

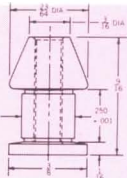

MODEL 173-13

A universal precision-made guide post for 1/4" tape — may readily be mounted to control the path of tape travel. Chrome plated brass insures long life and friction-free operation. Height is readily adjustable by loosening the locking set screw and rotating the threaded post.

## CARTRIDGE MOUNTING BRACKETS

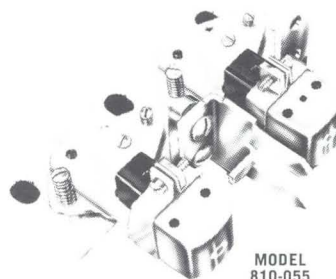
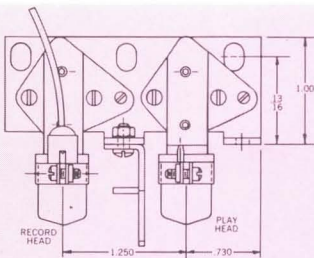

MODEL 810-045

Unique head mounting assembly for endless loop cartridge tape handlers (Fidelipac and Viking types). Eliminates awkward mounting and adjustment problems of rear-mount style heads. Offers "Micrometer" adjustments of head height, azimuth, and face perpendicularity. Lock screw on each head bracket "freezes" adjustments. Heads fastened to bracket with quick-release screw clamp. Replacement time is a matter of seconds when heads are connected with plug and cable assemblies provided with kits.

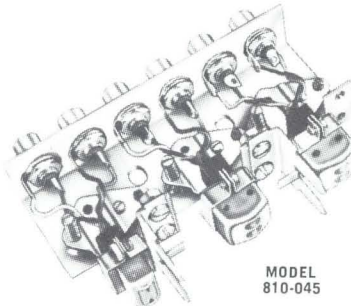
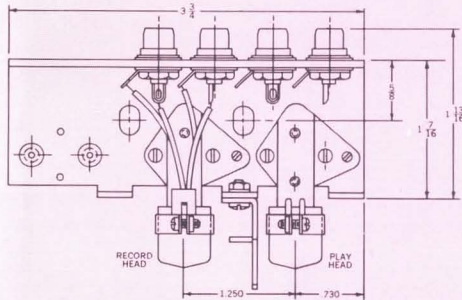

MODEL 810-046

**#810-045 "B" Cartridge-Mount Kit.** Up to three heads may be mounted on this assembly, using two no-mount R/P heads of the "A" or "B" size. A small case erase head may be added in the third position on the channel base by means of a #810-044 head bracket. Kit supplied unassembled, includes base channel, four jacks, two #810-042 brackets for the R/P  $\phi$  Combo heads, one #173-16 tape guide fork, and two plug and cable assemblies.

**#810-046 "G" Cartridge-Mount Kit.** As above, but with two #810-043 brackets for "G" or "T" size mono R/P heads.

**#810-055 "B" Two Head Cartridge-Mount Kit.** Accommodating two no-mount R/P heads of "A" or "B" size. Vertical back rail and jacks have been eliminated. Connection to the heads may be made by use of the 18" shielded plug and cable assemblies (provided).

**#810-056 "G" Two Head Cartridge-Mount Kit.** As above, but with #810-043 brackets "G" or "T" size mono R/P heads.

**#173-17 Brake-Release Guide** — for larger Viking metal cartridges.

## UNIVERSAL MOUNTING BRACKETS

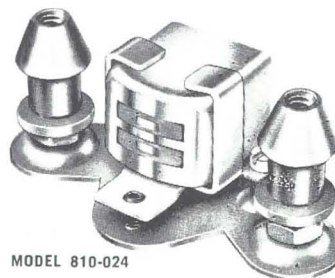
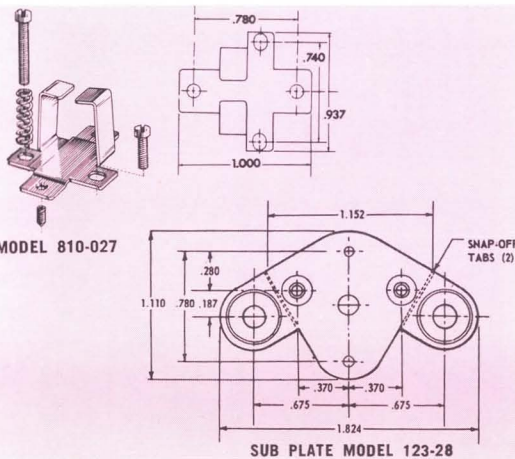

MODEL 810-024

Designed for simplified mounting plus ease in adjustments.

These universal head mounting brackets provide for convenient adjustment of head azimuth height and tilt. Heads are easily snapped in and out of brackets, which are accurately positioned by means of "Micrometer" adjustment screws. Brackets are made of cadmium-plated steel and are supplied with mounting screws and spring—and can be combined with other Nortronics accessories to make various mounting assemblies.

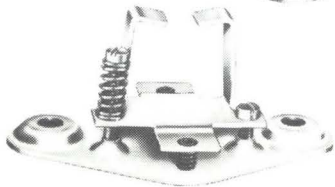

**#810-024 Head Nest.** Includes bracket, guide posts and mounting plate for "A" and "B" Heads.

**#810-027 Bracket.** For "A", "B", and "E" style no-mount heads.

**#810-028 Bracket.** For "G" size heads.

**#810-041 Bracket.** For small-case no-mount erase heads.



# NORTRONICS DISTRIBUTOR PART NUMBER CROSS-REFERENCE

For laboratory, prototype, and replacement needs, get Nortronics heads from your local distributor. He offers immediate delivery of the wide variety of heads listed below, at factory prices. Check the cross-reference for the head you need and the applicable distributor part number.

O.E.M. NUMBER	DISTRIBUTOR EQUIVALENT	O.E.M. NUMBER	DISTRIBUTOR EQUIVALENT	O.E.M. NUMBER	DISTRIBUTOR EQUIVALENT	O.E.M. NUMBER	DISTRIBUTOR EQUIVALENT
PB2L4R-N	5813	PB2H2K-N	2000	PA2H44R-N	6101	SSEH1-N	2200
PB2L8R-N	5810	PB2H3R-N	8203	PA2H47-N	6100	SSEH1-R	2250
B2L7K-N	5800	PB2H4K-N	2002	PA1HC44R-N	6126	SSEH2-N	2202
ZJ2L47K-N	6800	PB2H4K-R	2052	PA1HC47K-N	6127	SSEH4-N	2201
PB2Q2K-N	8600	PB2H4R-N	2003	A1HC11K-N	6125	SSEH4-R	2251
PB2Q6K-N	8607	PB2H4R-R	2053	A1HC47R-N	6129	SSEH9-N	2203
PB2Q8K-N	8610	PB2H6K-N	2007	A1HC47R-R	7457	LSEH1-N	2200L
PB2Q14R-N	8614	PB2H6K-R	2057	A1HC46K-N	6128	LSEH4-N	2201L
PB2Q2K-R	1250	PB2H7F-N	2021	PRB1F11R-N	9104	LMEH1-N	3600L
PB2Q3R-N	8602	PB2H7K-R	2051	PRB1F11R-B	9101	LMEH4-N	601L
PB2Q2K-N	1200	PB2H7K-N	2001	PRB1F12N-N	9102	SMEH1-N	3600
PB2Q4K-N	1202	PB2H7R-R	2055	PRB1F12N-B	9100	SMEH1B-1	7408
PB2Q4K-R	1252	PB2H7R-N	2005	PRB1F8R-N	9103	SMEH1-R	3650
PB2Q4R-N	1203	PB2H8R-N	2010	SLFH3L-R	4150	SMEH1A-N	7407
PB2Q6K-N	1207	B2H2K-N	1800	SLFH3L-N	4100	SMEH2-N	3602
PB2Q6K-R	1257	B2H2K-R	1850	SLFH4L-N	4102	SMEH4-N	3601
PB2Q7F-N	1221	B2H4K-N	1802	SLFH4L-R	4152	SMEH4-R	3651
PB2Q7K-R	1251	B2H4K-R	1852	SLFH4R-N	4101	SMEH9-N	3604
PB2Q7K-N	1201	B2H7K-N	1801	SLFH6L-N	8008	LMEF1-N	4400
PB2Q7R-N	1205	B2H7K-R	1851	SLFH7R-N	4103	LMEF4-N	4401L
PB2Q8R-N	8604	APB2H14R-N	8215	PB3Q4K-N	5702	SMEF1J-N	4400
B2Q2K-N	1000	APB2H8K-N	8211	PB3Q4K-R	5752	SMEF4J-N	4401
B2Q2K-R	1050	WPB1HY2K-N	8400	PB3Q4R-N	5703	SMEF4-R	4451
B2Q2N2-N	1009	WPB1HY7F-N	8406	PB3Q4R-R	5753	SMEF9J-N	4402
B2Q4K-N	1002	WPB1HY7K-N	8403	PB3Q6K-N	5707	PRB1EF14-B	9130
B2Q4K-R	1052	WPB1HY8K-N	8402	PB3Q6K-R	5757	PRB1EF9-N	9125
B2Q6K-N	1007	WPB1HY9K-N	8409	PB3Q7K-N	5701	PRB2EH14-B	9221
B2Q6N2-N	1008	PG1H2K-R	3250	PB3Q7K-R	5751	PRB2EH4-N	9226
B2Q7K-N	1001	PG1H2K-N	3200	PB3Q8R-N	5710	PRB2EH5-N	9222
B2Q7K-R	7654	PG1H4K-R	3252	PBQL14R-N	5836	B2EQ1-N	8704
B2Q8K-R	1051	PG1H4K-N	3202	PBQL4K-N	5833	B2EQ2-N	8702
G2Q2K-N	7600	PG1H4R-R	3253	PBQL4R-N	5834	B2EQ4-N	8701
G2Q6K-N	7603	PG1H4R-N	3203	PBQL6K-N	5832	B2EQ8-N	8708
PB1QY6F-N	7610	PG1H7K-R	3251	PBQL8R-N	5835	B1EH1-N	8501
PA2Q17K-N	6000	PG1H7K-N	3201	PBOQ23R-N	5604	B1EH4-N	8504
PA2Q44R-N	6004	PG1H7R-R	3255	PBQQ4K-R	5652	B1EH6-N	8506
PA2Q47K-N	6002	PG1H7R-N	3205	PBQQ4K-N	5602	B1EH9-N	8509
PA2Q48R-N	6006	PB1HY2K-N	2600	PBQQ4L-N	5600	B2EH1-N	8301
A2Q42N2-N	6009	PB1HY4K-N	2602	PBQQ4R-N	5601	B2EH2-N	8302
A2Q46K-R	6055	PB1HY4R-N	2603	PBQQ4R-R	5651	B2EH4-N	8304
UA2Q22K-N	6003	PB1HY6K-N	8408	PBQQ7K-N	5603	B2EH6-N	8306
UA2Q46K-N	6005	PB1HY7K-N	2601	PBQQ7K-R	5653	B2EH9-N	8309
A1QC22K-N	6025	PB1HY8R-N	8401	L42E6U-R	5360	B1EF1J-N	8101
A1QC47K-N	6026	XPC1HC7K-R	7458	L24R8L5-R	4950	B1EF2J-N	8102
PRB2H11R-N	9204	G1H2K-R	3050	LSEQ1-N	1400L	B1EF4J-N	8104
PRB2H12L-N	9202	G1H2K-N	3000	LSEQ4-N	1401L	B1EF5J-N	8105
PRB2H8R-N	9203	G1H4K-R	3052	SSEQ1-N	1400	B1EF6J-N	8106
WPB2H2K-N	8200	G1H4K-N	3002	SSEQ1-R	1450	B1EF9J-N	8109
WPB2H6K-N	8202	G1H7K-R	3051	SSEQ2-N	1402	STP4B7	9461
WPB2H7F-N	8208	G1H7K-N	3001	SSEQ3-N	1404	STP4B8	9460
WPB2H7K-N	8209	G1HY2K-R	7456	SSEQ4-N	1401	STE4B6	9470
WPB2H8K-N	8210	G1HY5L-N	7406	SSEQ4-R	1451	STP4B6	9470
PB2H14R-N	8214	B1HY2K-R	7450	SSEQ7-N	1407		
PB2H2K-R	2050			SSEQ8-N	1408		

Standard Side and Base Mounting Brackets (as illustrated on previous pages) are normally supplied attached to head as specified. They may, however, be ordered separately. Mounting brackets for Distributor heads must be purchased separately. Specify as follows:

	O.E.M. NUMBER	"B" SIZE CASE	"G" SIZE CASE	ERASE "S" SIZE
<b>BASE MOUNT CLIP</b>	<b>DISTRIBUTOR EQUIVALENT</b>	109-146	109-154	-
	<b>DISTRIBUTOR EQUIVALENT</b>	QK-66	QK-21	QK-19
<b>SIDE MOUNT CLIP</b>	<b>O.E.M. NUMBER</b>	109-188	109-20	-
	<b>DISTRIBUTOR EQUIVALENT</b>	QK-38	QK-20	QK-18



FOR  
MORE  
INFORMATION  
ABOUT  
NORTRONICS  
PRODUCTS  
and  
SERVICES,  
SEND US  
THE  
POSTAGE-FREE  
CARD

(Cards all gone?) Write—



**Nortronics**  
COMPANY, INC.

8101 Tenth Avenue, North  
Minneapolis, Minn. 55427

*I'd like more information about Nortronics products and services,  
as indicated below.*

- Send catalog data on digital heads
- Send a duplicate copy of this catalog for a colleague \_\_\_\_\_  
for library use \_\_\_\_\_
- Send name of local distributor
- Please have your sales engineer call
- Send information on \_\_\_\_\_

Name \_\_\_\_\_ Title \_\_\_\_\_

Company \_\_\_\_\_

City \_\_\_\_\_ State \_\_\_\_\_ Zip \_\_\_\_\_

Phone: Area Code \_\_\_\_\_ Number \_\_\_\_\_ Extension \_\_\_\_\_

*I'd like more information about Nortronics products and services,  
as indicated below.*

- Send catalog data on digital heads
- Send a duplicate copy of this catalog for a colleague \_\_\_\_\_  
for library use \_\_\_\_\_
- Send name of local distributor
- Please have your sales engineer call
- Send information on \_\_\_\_\_

Name \_\_\_\_\_ Title \_\_\_\_\_

Company \_\_\_\_\_

City \_\_\_\_\_ State \_\_\_\_\_ Zip \_\_\_\_\_

Phone: Area Code \_\_\_\_\_ Number \_\_\_\_\_ Extension \_\_\_\_\_

*I'd like more information about Nortronics products and services,  
as indicated below.*

- Send catalog data on digital heads
- Send a duplicate copy of this catalog for a colleague \_\_\_\_\_  
for library use \_\_\_\_\_
- Send name of local distributor
- Please have your sales engineer call
- Send information on \_\_\_\_\_

Name \_\_\_\_\_ Title \_\_\_\_\_

Company \_\_\_\_\_

City \_\_\_\_\_ State \_\_\_\_\_ Zip \_\_\_\_\_

Phone: Area Code \_\_\_\_\_ Number \_\_\_\_\_ Extension \_\_\_\_\_

**BUSINESS REPLY MAIL** *No postage stamp necessary if mailed in the United States*

*Postage will be paid by*

**NORTRONICS**  
8101 Tenth Avenue North  
Minneapolis, Minnesota 55427

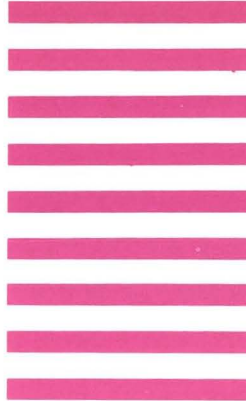

FIRST CLASS  
PERMIT NO. 7614  
MINNEAPOLIS, MINN.

**BUSINESS REPLY MAIL** *No postage stamp necessary if mailed in the United States*

*Postage will be paid by*

**NORTRONICS**  
8101 Tenth Avenue North  
Minneapolis, Minnesota 55427

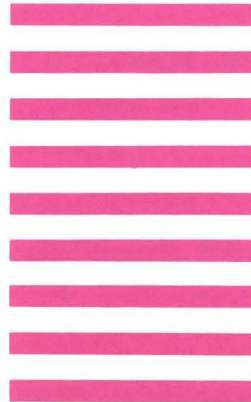

FIRST CLASS  
PERMIT NO. 7614  
MINNEAPOLIS, MINN.

**BUSINESS REPLY MAIL** *No postage stamp necessary if mailed in the United States*

*Postage will be paid by*

**NORTRONICS**  
8101 Tenth Avenue North  
Minneapolis, Minnesota 55427

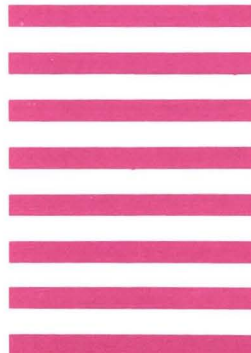

FOR  
MORE  
INFORMATION  
ABOUT  
NORTRONICS  
PRODUCTS  
and  
SERVICES,  
SEND US  
THE  
POSTAGE-FREE  
CARD

(Cards all gone?) Write-



**Nortronics**  
COMPANY, INC.

8101 Tenth Avenue, North  
Minneapolis, Minn. 55427



# NORTRONICS

## magnetic recording reference list

As a service to its customers, Nortronics presents a list of publications and books dealing with the theory and practice of magnetic recording. The complete technical library should be stocked with all or most of the following titles.

### RECORDING THEORY AND PRACTICE (SEMITECHNICAL)

**ABC'S OF TAPE RECORDING.** Crowhurst. 96 pp. Non-technical. (*Howard Sams Publication No. 20395*) \$1.50

**TAPE RECORDING FOR THE HOBBYIST.** Zuckerman. 160 pp. 1968 (*Howard Sams Publication No. 20593*) \$3.95

**TAPE RECORDERS — HOW THEY WORK.** Westcott & Dubbe. 234 pp. 1964. Excellent general-purpose semi-technical reference for audio recorders. Goes into motors, heads, circuits, equalization, etc. (*Howard Sams Publication No. 20290*) \$2.50

**PRACTICAL GUIDE TO TAPE RECORDERS.** Audell's. 277 pp. 1965 (*Howard Sams Publication No. 60127*) \$4.95

### RECORDING THEORY AND PRACTICE (TECHNICAL — GENERAL)

**MAGNETIC RECORDING TECHNIQUES.** Stewart. 270 pp. 1958. Basic reference and text. (*McGraw-Hill*)

**MAGNETIC TAPE RECORDING.** Spratt. 369 pp. 1964. Basic reference and text. (*Temple Press Books Ltd., London, England*)

**PHYSICS OF MAGNETIC RECORDING, VOL. II.** C.D. Mee. 270 pp. 1964. Fundamental theory and concepts, much on magnetic tape. (*John Wiley & Sons*)

**MAGNETIC TAPE RECORDING.** Athey. 326 pp. 1966. Mostly on instrumentation recording, with many photos and descriptions of specialized recorders for space probes, etc. (*NASA No. SP-5038, National Aeronautics and Space Administration, Washington, D.C.*) Order from: U.S. Government Printing Office, Washington, D.C. 20402. \$1.25

**MAGNETIC RECORDING IN SCIENCE AND INDUSTRY.** Pear. 450 pp. 1967. Principles, recording media, transports, accessories, analog, digital, drums, discs and control applications. (*Reinhold Publishing Corporation, New York*) \$19.50

**DIGITAL MAGNETIC RECORDING.** Albert Hoaglund. 154 pp. 1963. Theory of magnetic recording as applied to the digital field; media, mass storage, heads, writing, reading, etc. With mathematical treatment. (*John Wiley*)

**MAGNETIC TAPE INSTRUMENTATION.** Gomer Davis. 263 pp. 1961. Instrumentation and digital recording. Basic reference. (*McGraw-Hill*)

**MAGNETIC RECORDING HANDBOOK.** Howard and Ferguson. 50 pp. 1966. Application notes on FM recording. (*A.N. 89, Hewlett Packard, Mountain View, California 94040*)

**MAGNETIC RECORDING THEORY FOR INSTRUMENTATION.** Lowman and Angerbauer. 112 pp. 1963. Application Notes and Theory on analog and digital recording. Used as basis of a course on instrumentation recording theory. (*Ampex Corporation Training Department, Redwood City, California 94063*)

### CIRCUITRY FOR MAGNETIC RECORDING

**TRANSISTOR AUDIO AMPLIFIERS.** Dwight Jones and Richard Shea. 267 pp. 1968. Basic theory of transistors and FET's, amplifiers, equalization and feedback, plus practical operating circuits. Includes an excellent section on tape recording amplifiers and functional circuits on stereo recording and playback amplifiers. (*John Wiley & Sons*)

**ELEMENTS OF TAPE RECORDER CIRCUITS.** Herman Burstein. 223 pp. 1966. (*Gernsback Library*)

**HANDBOOK OF TRANSISTOR CIRCUITS.** Alan Lytel. 200 circuits on counters, timers, flip-flops, amplifiers, oscillators, etc. (*Howard Sams Publication No. 20399*) \$5.50

**INDUSTRIAL TRANSISTOR CIRCUITS.** 111 pp. 1968. (*Howard Sams Publication No. 20245*) \$2.75

### VIDEO RECORDING

**VIDEO RECORDING.** Julian Bernstein. 268 pp. 1960. Semi-technical basic reference. (*John F. Rider Publications*)

**TELEVISION TAPE RECORDING FUNDAMENTALS.** Harold Ennes. 256 pp. (*Howard Sams Publication No. 20065*) \$5.95

### SERVICING AND REPAIR OF RECORDERS

**TAPE RECORDER SERVICE MANUAL AND TROUBLESHOOTING WORKBOOK.** Robert Marshall. 128 pp. 1962. (*Chilton Company, Philadelphia*)

**"TR" TAPE RECORDER SERIES MANUALS.** Over 50 service manuals (TR-1, TR-2, etc.) issued on a continuing basis, from 1958 to present, covering U.S. and foreign reel-to-reel, Cartridge and Cassette record/playback (not play-only) machines. Each volume has complete index by models of all recorders covered previously. (*Howard W. Sams & Company, Indianapolis, Indiana*) \$4.95 each



## SERVICING AND REPAIR OF RECORDERS

**"HTP" SERIES, HOME TAPE PLAYER SERVICE MANUALS.** (HTP-1, HTP-2, etc.) This manual series covers machines which play pre-recorded tape cartridges, but which do not make recordings. Included are those using the endless-loop 8-Track Stereo ("Stereo-8") and 4-track stereo cartridges, plus the CASSETTE type reel-to-reel cartridge players. Home players only are covered — see Auto Radio series below for automobile tape players. (Howard W. Sams) \$4.95 each

**"AR" SERIES, AUTO RADIO AND TAPE PLAYER SERVICE MANUALS.** (AR-1, AR-2, etc.) Covers Cartridge and Cassette type auto tape players along with radios. Each manual has complete index by model. (Howard W. Sams) \$4.95 each

**NORTRONICS TAPE HEAD REPLACEMENT AND CONVERSION GUIDE. 6TH EDITION.** Full listing of thousands of U.S. and foreign tape recorders by model numbers, with recommended NORTRONICS replacement or conversion heads. Also cross-indexed by original head part number, showing equivalent NORTRONICS head model. (NORTRONICS COMPANY, INC., 8101 10th Avenue North, Minneapolis, Minnesota 55427) \$5.00 for Complete Guide. Free for Condensed Guide.

### STANDARDS — MAGNETIC RECORDING

**NAB REEL-TO-REEL MAGNETIC TAPE RECORDING AND REPRODUCING STANDARD.** 30 pp. 1965. (National Association of Broadcasters, 1771 N-Street N.W., Washington, D.C. 20006)

**NAB CARTRIDGE TAPE RECORDING AND REPRODUCING STANDARD.** 27 pp. 1964. Two and three-channels on 1/4-inch tape cartridges for radio station applications. (Above address)

**RIAA STANDARDS FOR MAGNETIC TAPE RECORDS, E-5.** 4 pp. 1969. Covers primarily home entertainment 1/4-inch pre-recorded tapes; reel-to-reel and endless-loop cartridges. Two, four, and eight-track dimensional information is presented. (Record Industry Association of America, Inc., One East 57th Street, New York, New York 10022)

**IRIG TELEMETRY STANDARDS NO. 106-66.** March, 1966. (Defense Documentation Center for Scientific and Technical Information, Cameron Station, Alexandria, Virginia 22314)

**"DIN" GERMAN INDUSTRIAL STANDARDS (Deutsche Industrie Normen).** Complete series of European standards on tape, heads, system performance, etc. In German, with many items available in English Translation. Write to: USASI, 10 East 40th Street, New York, New York 10016 for listing and prices.

**LIST OF PUBLISHED STANDARDS RELATING TO MAGNETIC SOUND RECORDING.** March, 1966. Fairly complete listing which includes S.M.P.T.E. standards on 8 mm., 16 mm. and 35 mm. magnetic sound stripe, plus various foreign and U.S. Government standards. (J.G. McKnight, AMPEX CORPORATION, P.O. 1166, Los Gatos, California 95030)

**1. TEST TAPE APPLICATIONS. 2. LEVEL AND FREQUENCY RESPONSE STANDARDIZATION IN MAGNETIC SOUND RECORDING.** Morrison and McKnight, 1967. Two pamphlets with articles reprinted from the Journal of the Audio Engineering Society. (Ampex Corporation, P.O. 1166, Los Gatos, California 95030)

(Electronic Industries Association, 2001 Eye Street N.W., Washington, D.C. 20006) Minimum \$1.00 per order:

**RS-288 AUDIO MAGNETIC PLAYBACK CHARACTERISTICS AT 7-1/2 IPS.** 1963. \$0.50

**RS- CP-II. (EIA Co-Planar Type II.) CASSETTE TAPE CARTRIDGE STANDARDS.** Under consideration; to be issued in 1970.

**RS-264 MAGNETIC RECORDING TAPE CARTRIDGE DIMENSIONS.** (Endless-loop type). 1962. \$0.50

**RS-224 MAGNETIC RECORDING TAPES.** 1959. \$0.60

**RS-332 DIMENSIONAL STANDARDS — ENDLESS LOOP MAGNETIC TAPE CARTRIDGES, TYPES EL-1, EL-2, and EL-3.** 1967. \$1.60

**RS-342 MAGNETIC TAPE, ELECTRICAL RESISTANCE COATING, RECOMMENDED TEST METHOD OF.** 1967. \$1.40

**RS-346 TYPE A REELS AND HUBS FOR MAGNETIC TAPE.** 1968. \$0.80

**RS-347 1/2 INCH TYPE B PLASTIC REEL.** 1968. \$0.80

**RS- EIA OPEN REEL REPRODUCER TEST TAPE.** (From S.P. 1030) For 7.5 and 3.75 ips tape speeds, includes reference level, azimuth and frequency response measurement sections. To be issued in 1970.

**RS-338 STANDARD FOR UNRECORDED MAGNETIC TAPE FOR REEL-TO-REEL INSTRUMENTATION.** 1967. \$0.50

**RS-362 TENSILE PROPERTIES OF MAGNETIC TAPE — TESTS.** June, 1969

**Nortronics**  
COMPANY, INC.



8107 Tenth Avenue North Minneapolis, Minnesota 55427  
Phone: (612) 545-0401