

The Engineering Staff of  
TEXAS INSTRUMENTS INCORPORATED  
Semiconductor Group



**The  
Interface  
Circuits  
Data Book**  
for  
**Design Engineers**

**Second Edition**

**TEXAS INSTRUMENTS**  
INCORPORATED



GENERAL INFORMATION	1
THERMAL INFORMATION	2
ORDERING INSTRUCTIONS AND MECHANICAL DATA	3
PERIPHERAL DRIVERS	4
LINE CIRCUITS	5
SENSE AMPLIFIERS	6
MOS DRIVERS	7
MEMORY DRIVERS	8
DISPLAY DRIVERS	9
JAN MIL-M-38510 INTEGRATED CIRCUITS	10
38510 MACH IV PROCUREMENT SPECIFICATION	11
IC SOCKETS	12

# TI Sales Offices

**ALABAMA:** Huntsville, 500 Wynn Drive, Suite 514, Huntsville, AL 35805, (205) 837-7530.

**ARIZONA:** Phoenix, P.O. Box 35160, 8102 N. 23rd Ave., Suite A, Phoenix, AZ 85069, (602) 249-1313.

**CALIFORNIA:** El Segundo, 831 S. Douglas St., El Segundo, CA 90245, (213) 972-2571; Irvine, 17620 Fitch, Irvine, CA 92714, (714) 545-5210; Sacramento, 1900 Point West Way, Suite 171, Sacramento, CA 95815, (916) 929-1521; San Diego, 4333 View Ridge Ave., Suite B, San Diego, CA 92123, (714) 278-9600; Sunnyvale, P.O. Box 9064, 775 Palomar Ave., Sunnyvale, CA 94068, (408) 732-1840.

**COLORADO:** Denver, 9725 E. Hampden St., Suite 301, Denver, CO 80231, (303) 695-2800.

**CONNECTICUT:** Wallingford, 9 Barnes Industrial Park Rd., Barnes Industrial Park, Wallingford, CT 06492, (203) 269-0074.

**FLORIDA:** Clearwater, 2280 U.S. Hwy. 19 N., Suite 232, Clearwater, FL 33515, (813) 325-1861; Ft. Lauderdale, 2765 N.W. 62nd St., Ft. Lauderdale, FL 33309, (305) 873-8502; Winter Park, 1850 Lee Rd., Suite 115, Winter Park, FL 32789, (305) 644-3535.

**GEORGIA:** Atlanta, 3300 Northeast Expy., Building 9, Atlanta, GA 30341, (404) 452-4600.

**ILLINOIS:** Arlington Heights, 515 W. Algonquin, Arlington Heights, IL 60005, (312) 640-2934.

**INDIANA:** Ft. Wayne, 2020 Inwood Dr., Ft. Wayne, IN 46805, (219) 424-5174; Indianapolis, 2346 S. Lynnhurst, Suite J-400, Indianapolis, IN 46241, (317) 248-8555.

**MARYLAND:** Baltimore 1 Rutherford Pl., 7133 Rutherford Rd., Baltimore, MD 21207, (301) 944-8600.

**MASSACHUSETTS:** Waltham, 504 Totten Pond Rd., Waltham, MA 02154, (617) 890-7400.

**MICHIGAN:** Southfield, Central Park Plaza, 26211 Central Park Blvd., Suite 215, Southfield, MI 48076, (313) 353-0830.

**MINNESOTA:** Edina, 7625 Parklawn, Edina, MN 55435, (612) 830-1600.

**MISSOURI:** Kansas City, 8080 Ward Pkwy., Kansas City, MO 64114, (816) 523-2500; St. Louis, 11861 Westline, Industrial Line Drive, St. Louis, MO 63141, (314) 569-7600.

**NEW JERSEY:** Clark, 292 Terminal Ave. West, Clark, NJ 07066, (201) 574-9800.

**NEW MEXICO:** Albuquerque, 5907 Alice N.E., Suite E, Albuquerque, NM 87110, (505) 265-8491.

**NEW YORK:** East Syracuse, 6700 Old Collamer Rd., East Syracuse, NY 13057, (315) 463-9291; Endicott, 112 Nanticoke Ave., P.O. Box 618, Endicott, NY 13760, (607) 754-3900; Melville, 1 Huntington Quadrangle, Suite 3C10, P.O. Box 2936, Melville, NY 11747, (516) 454-6600; Poughkeepsie, 201 South Ave., Poughkeepsie, NY 12601, (914) 473-2900; Rochester, 1210 Jefferson Rd., Rochester, NY 14623, (716) 424-5400.

**NORTH CAROLINA:** Charlotte, 8 Woodlawn Green, Woodlawn Rd., Charlotte, NC 28210, (704) 527-0930.

**OHIO:** Beachwood, 23408 Commerce Park Rd., Beachwood, OH 44122, (216) 464-6100; Dayton, Kingsley Bldg., 4124 Linden Ave., Dayton, OH 45432, (513) 258-3877.

**OKLAHOMA:** Tulsa, 3105 E. Skelly Dr., Suite 512, Tulsa, OK 74105, (918) 749-9547.

**OREGON:** Beaverton, 6700 SW 105th St., Suite 110, Beaverton, OR 97005, (503) 643-6758.

**PENNSYLVANIA:** Ft. Washington, 575 Virginia Dr., Ft. Washington, PA 19034, (215) 643-6450.

**TENNESSEE:** Johnson City, P.O. Drawer 1255, Erwin Hwy., Johnson City, TN 37601, (615) 461-2129.

**TEXAS:** Austin, 12501 Research Bldg., P.O. Box 2909, Austin, TX 78723, (512) 250-7655; Dallas, P.O. Box 225012, Dallas, TX 75265, (214) 955-6531; Houston, 9000 Southwest Fwy., Suite 400, Houston, TX 77036, (713) 778-6592.

**UTAH:** Salt Lake City, 3672 West 2100 South, Salt Lake City UT 84120, (801) 973-6310.

**VIRGINIA:** Fairfax, 3001 Prosperity, Fairfax, VA 22031, (703) 849-1400; Midlothian, 13711 Sutter's Mill Circle, Midlothian, VA 23113, (804) 744-1007.

**WASHINGTON:** Redmond, 2723 152nd Ave., N.E. Bldg. 6, (206) 881-3089, Redmond, WA 98052.

**CANADA:** Ottawa, 436 McClellan St., Ottawa, Canada, K2P0M8, (613) 233-1177; Richmond Hill, 280 Centre St., Richmond Hill L4C1B1, Ontario, Canada, (416) 884-9181; St. Laurent, Ville St. Laurent Quebec, 9460 Trans Canada Hwy., St. Laurent, Quebec, Canada H4S1R7, (514) 334-3635. K

# TI Distributors

**ALABAMA:** Huntsville, Hall-Mark (205) 837-8700.

**ARIZONA:** Phoenix, Kierulff Electronics (602) 243-4101; R.V. Weatherford (602) 272-7144; Tempe, Marshall Industries (602) 968-6181; Tucson, Kierulff (602) 624-9986.

**CALIFORNIA:** Anaheim, R.V. Weatherford (714) 634-9600; Canoga Park, Marshall Industries (213) 999-5001; Chatsworth, JACO (213) 998-2200; Costa Mesa, TI Supply (714) 979-5391; El Monte, Marshall Industries (213) 686-0141; El Segundo, TI Supply (213) 973-5150; Glendale, R.V. Weatherford (213) 849-3451; Galea, RPS (805) 964-8823; Irvine, JACO (714) 540-5600; Marshall Industries (714) 556-6400; Los Angeles, Kierulff Electronics (213) 725-0325; RPS (213) 748-1271; Palo Alto, Kierulff Electronics (415) 968-6292; Pomona, R.V. Weatherford (714) 623-1261; Sacramento, TI Supply (916) 924-8521; San Diego, Arrow Electronics (714) 585-4800; Kierulff Electronics (714) 278-2112; Marshall Industries (714) 578-9600; R.V. Weatherford (714) 278-7400; Santa Barbara, R.V. Weatherford (805) 465-8551; Santa Clara, United Components (408) 496-8900; Sunnyvale, Arrow Electronics (408) 745-8600; Marshall Industries (408) 732-1100; Time Electronics (408) 734-9888; TI Supply (408) 732-5555; United Components (408) 496-8900; Torrance, Time Electronics (213) 320-0880; Tuslin, Kierulff Electronics (714) 731-5711.

**COLORADO:** Denver, Arrow Electronics (303) 758-2100; Diploma/Denver, (303) 740-8300; Kierulff Electronics (303) 371-6500; Englewood, R.V. Weatherford (303) 770-9762.

**CONNECTICUT:** Orange, Milgray/Connecticut (203) 795-0714; Wallingford, Arrow Electronics (203) 265-7741; Marshall Industries (203) 265-3822; TI Supply (203) 281-4669.

**FLORIDA:** Clearwater, Diplomat/Southland (813) 443-4514; Ft. Lauderdale, Arrow Electronics (305) 973-8502; Diplomat/Ft. Lauderdale (305) 971-7160; Hall-Mark/Miami (305) 971-9280; Orlando, Hall-Mark/Orlando (305) 855-4020; Palm Bay, Arrow Electronics (305) 725-1480; Diplomat/Florida (305) 725-4520; St. Petersburg, Kierulff Electronics (813) 576-1966; Winter Park, Milgray Electronics (305) 647-5747.

**GEORGIA:** Norcross, Arrow Electronics (404) 449-8252; Marshall Industries (404) 923-5750.

**ILLINOIS:** Arlington Heights, TI Supply (312) 640-2964; Bensenville, Hall-Mark/Chicago (312) 860-3800; Elk Grove Village, Kierulff Electronics (312) 640-0200; Chicago, Newark Electronics (312) 638-4411; Schaumburg, Arrow Electronics (312) 893-9420.

**INDIANA:** Ft. Wayne, Ft. Wayne Electronics (219) 423-3422; Indianapolis, Graham Electronics (317) 634-8202; Arrow Electronics (317) 243-9353; TI Supply (800) 325-1039.

**IOWA:** Cedar Rapids, Deeco (319) 365-7551.

**KANSAS:** Lenexa, Component Specialties (913) 492-3555; Shawnee Mission, Hall-Mark/Kansas City (913) 888-4747; Wichita, LCOMP Inc. (316) 265-9507.

**MARYLAND:** Baltimore, Arrow Electronics (202) 737-1700, (301) 247-5200; Hall-Mark/Baltimore (301) 796-9300; Columbia, Diplomat/Maryland (301) 995-1226; Rockville, Milgray/Washington (301) 466-8400.

**MASSACHUSETTS:** Billerica, Kierulff Electronics (617) 667-8331; Burlington, Marshall Industries (617) 272-8200; Waltham, TI Supply (617) 890-0510; Woburn, Arrow Electronics (617) 933-8130; Time Electronics (617) 935-8080.

**MICHIGAN:** Ann Arbor, Arrow Electronics (313) 971-8200; Oak Park, Newark Electronics (313) 967-0600; Farmington, Diplomat (313) 477-3200; Grand Rapids, Newark Electronics (616) 241-6681.

**MINNESOTA:** Edina, Arrow Electronics (612) 830-1800; Kierulff Electronics (612) 835-4388; Minneapolis, Diplomat (612) 788-8601.

**MISSOURI:** Earth City, Hall-Mark/St. Louis (314) 291-5350; Kansas City, LCOMP Inc.-Kansas City (816) 221-2400; TI Supply (816) 753-4750; St. Louis, Arrow Electronics (314) 567-6888; LCOMP Inc.-St. Louis (314) 291-6200; TI Supply (314) 569-2258.

**NEW HAMPSHIRE:** Manchester, Arrow Electronics (603) 668-6968.

**NEW JERSEY:** Camden, General Radio Supply (609) 964-8580; Cherry Hill, Hall-Mark (609) 424-0880; Clark, TI Supply (201) 382-6400; Clifton, Marshall Industries (201) 340-1900; Fairfield, Kierulff Electronics (201) 575-6750; Marlton, Milgray/Delaware Valley (609) 424-1300; Moorestown, Arrow Electronics (609) 235-1900; Saegertown, Arrow Electronics (201) 797-5600; Totowa, Diplomat/New Jersey (201) 785-1830.

**NEW MEXICO:** Albuquerque, Arrow Electronics (505) 243-4566; International Electronics (505) 345-8127; United Components (505) 345-9981.

**NEW YORK:** Endwell, Marshall Industries (607) 754-1570; Freeport, Milgray Electronics (516) 546-5800, N.Y. (800) 645-3986; Hauppauge, Arrow Electronics (516) 231-1000; JACO (516) 273-5500; Liverpool, Arrow/Syracuse (315) 652-1000; Diplomat (516) 652-5000; Melville, Diplomat (516) 454-6400; Rochester, Arrow/Rochester (716) 275-0300; Rochester Radio Supply (716) 454-7800; Marshall Industries (716) 235-7620.

**NORTH CAROLINA:** Raleigh, Arrow Electronics (919) 876-3132; Hall-Mark (919) 832-4465; Winston-Salem, Arrow Electronics (919) 725-8711.

**OHIO:** Centerville, Arrow Electronics (513) 435-5563; Cleveland, TI Supply (216) 464-6100; Cincinnati, Graham Electronics (513) 732-1631; Columbus, Hall-Mark/Ohio (614) 846-1882; Dayton, ESCO Electronics (513) 226-1133; Marshall Industries (513) 236-8088; Highland Heights, Hall-Mark/Cleveland (216) 473-2907; Sion, Arrow Electronics (216) 248-3990.

**OKLAHOMA:** Tulsa, Component Specialties (918) 664-2820; Hall-Mark/Tulsa (918) 835-8458; TI Supply (918) 749-9543.

**OREGON:** Beaverton, Almac/Stroum Electronics (503) 641-9070; Portland, Kierulff Electronics (503) 641-9150.

**PENNSYLVANIA:** Pittsburgh, Arrow Electronics (412) 856-7000.

**TEXAS:** Austin, Component Specialties (512) 837-8922; Hall-Mark/Austin (512) 837-2814; Harrison Equipment (512) 458-3555; Dallas, Component Specialties (214) 357-6511; Hall-Mark/Dallas (214) 341-1147; International Electronics, (214) 233-9323; TI Supply (214) 238-6882; El Paso, International Electronics (915) 778-9761; Houston, Component Specialties (713) 771-7237; Hall-Mark/Houston (713) 781-6100; Harrison Equipment (713) 652-4700; TI Supply (713) 776-6530.

**UTAH:** Salt Lake City, Diplomat/Altland (801) 466-4134; Kierulff Electronics (801) 973-6913.

**WASHINGTON:** Redmond, United Components (206) 885-1985; Seattle, Almac/Stroum Electronics (206) 763-2300; Kierulff Electronics (206) 575-4420; Tukwila, Arrow Electronics (206) 575-0607.

**WISCONSIN:** Oak Creek, Arrow Electronics (414) 764-6600; Hall-Mark/Milwaukee (414) 761-3000; Waukesha, Kierulff Electronics (414) 784-8160.

**CANADA:** Calgary, Cam Gard Supply (403) 287-0520; Future Electronics (403) 259-6408; Downsview, CESCO Electronics (416) 661-0220; Edmonton, Cam Gard Supply (403) 426-1805; Halifax, Cam Gard Supply (902) 454-8581; Kamloops, Cam Gard Supply (604) 372-3336; Moncton, Cam Gard Supply (506) 855-2200; Montreal, CESCO Electronics (514) 735-5511; Future Electronics (514) 731-7441; Ottawa, CESCO Electronics (613) 729-5118; Future Electronics (613) 820-8313; Quebec City, CESCO Electronics (418) 687-4231; Regina, Cam Gard Supply (306) 325-1317; Saskatoon, Cam Gard Supply (306) 652-8424; Toronto, Future Electronics (416) 663-5563; Vancouver, Cam Gard Supply (604) 291-1441; Future Electronics (604) 438-5545; Winnipeg, Cam Gard Supply (204) 786-8481. A

## TEXAS INSTRUMENTS INCORPORATED



# The Interface Circuits Data Book

for  
**Design Engineers**

**Second Edition**



**TEXAS INSTRUMENTS**  
INCORPORATED

LCC5921  
71001-51-G

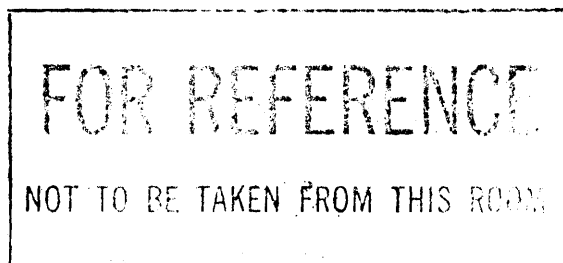

Printed in U.S.A.

## IMPORTANT NOTICES

Texas Instruments reserves the right to make changes at any time in order to improve design and to supply the best product possible.

TI cannot assume any responsibility for any circuits shown or represent that they are free from patent infringement.

Information contained herein includes data previously published in:

*The Interface Circuits Data Book, First Edition LCC4330*

*The Line Driver and Line Receiver Data Book, 1981 LCC4290A*

*The Peripheral Driver Data Book, 1981 LCC4280A*

*The Memory Interface Data Book, 1977 LCC4300*

*The Display Driver Data Book, 1977 LCC4310*

Some corrections to the previously published data have been made in this book, which represents the most recent data on these interface circuits at the time of publication.

ISBN 0-89512-109-3

Library of Congress catalog number: 81-51166

Copyright © 1981

Texas Instruments Incorporated

# General Information

10/10/10 10:10:10

## TABLE OF CONTENTS

	PAGE
Alphanumeric Index . . . . .	1-4
Interchangeability Guide . . . . .	1-6
Thermal Information . . . . .	2-3
Ordering Instructions and Mechanical Data . . . . .	3-3
Peripheral Driver Selection Guide . . . . .	4-2
Peripheral Driver Data Sheets . . . . .	4-5
Peripheral Driver Applications . . . . .	4-117
Line Driver and Line Receiver Selection Guide . . . . .	5-3
Line Driver and Line Receiver Data Sheets . . . . .	5-11
Line Circuits Applications . . . . .	5-261
Sense Amplifier Selection Guide . . . . .	6-2
Sense Amplifier Data Sheets . . . . .	6-3
MOS Driver Selection Guide . . . . .	7-2
MOS Driver Data Sheets . . . . .	7-5
Memory Driver Selection Guide . . . . .	8-2
Memory Driver Data Sheets . . . . .	8-3
Display Driver Selection Guide . . . . .	9-2
Display Driver Data Sheets . . . . .	9-5
JAN MIL-M-38510 Integrated Circuits . . . . .	10-1
38510/MACH IV Procurement Specification . . . . .	11-1
IC Sockets . . . . .	12-1



## ALPHANUMERIC INDEX

		PAGE			PAGE
	AM26LS31C	5-11	SN55138	SN75138	5-121
	AM26LS32AC	5-15	SN55140	SN75140	5-127
	AM26LS33AC	5-15	SN55141	SN75141	5-127
AM26S10M	AM26S10C	5-21	SN55142A	SN75142A	5-127
AM2611M	AM26S11C	5-21	SN55143A	SN75143A	5-127
DS7831	DS8831	5-25		SN75150	5-135
DS7832	DS8832	5-25	SN55151	SN75151	5-139
	MC3446	5-31		SN75152	5-146
	MC3486	5-35	SN55153	SN75153	5-139
	MC3487	5-39		SN75154	5-153
	N8T26	5-43		SN75156*	5-158
	N8T26A	5-43	SN55157	SN75157	5-159
SN5520	SN7520	6-3	SN55158	SN75158	5-162
SN5522	SN7522	6-3		SN75159	5-166
SN5524	SN7524	6-3		SN75160A	5-171
SN5528	SN7528	6-3		SN75161A	5-177
	SN75064	4-5		SN75162A	5-177
	SN75065	4-5		SN75163A	5-184
	SN75066	4-5		SN75172	5-187
	SN75067	4-5		SN75173	5-192
	SN75068	4-9		SN75174	5-197
	SN75069	4-9		SN75175	5-202
	SN75074	4-13		SN75176	5-207
	SF75075	4-13		SN75177	5-215
SN55107A	SN75107A	5-49		SN75178	5-215
SN55107B	SN75107B	5-49	SN55180,		7-5
SN55108A	SN75108A	5-49	SN55182	SN75182	5-223
SN55108B	SN75108B	5-49	SN55183	SN75183	5-223
SN55109A	SN75109A	5-61		SN75186*	5-234
SN55110A	SN75110A	5-61		SN75187*	5-235
	SN75112	5-61		SN75188	5-237
→SN55113	SN75113	5-69		SN75189	5-241
SN55114	SN75114	5-69		SN75189A	5-241
SN55115	SN75115	5-69		SN75207	5-245, 6-53
SN55116	SN75116	5-87		SN75207B	5-245, 6-53
SN55117	SN75117	5-87		SN75208	5-245, 6-53
SN55118	SN75118	5-87		SN75208B	5-245, 6-53
SN55119	SN75119	5-87	SN55232	SN75232	6-3
SN55121	SN75121	5-95	SN55234	SN75234	6-3
SN55122	SN75122	5-95	SN55238	SN75238	6-3
	SN75123	5-101		SN75270	6-59, 9-5
	SN75124	5-101		SN75320	7-8
	SN75125	5-107		SN75321	7-8
	SN75126*	5-111		SN75322	7-13
	SN75127	5-107		SN75324	8-3
	SN75128	5-112	SN55325	SN75325	8-10
	SN75129	5-112	SN55326	SN75326	8-25
	SN75130*	5-116	SN55327	SN75327	8-25
	SN75136	5-117		SN75328	8-31

\* Future products, to be announced



## ALPHANUMERIC INDEX

	PAGE		PAGE
SN75330	8-31	SN75467	4-73
SN75350	7-17	SN75468	4-73
SN75355	7-21	SN75469	4-73
SN75357	7-25	SN55470	4-81
SN75361A	7-30	SN55471	4-81
SN75363	7-39	SN55472	4-81
SN75364	7-43	SN55473	4-81
SN75365	7-48	SN55474	4-81
SN75366	7-57	SN75476	4-91
SN75367	7-63	SN75477	4-91
SN75368	7-67	SN75478	4-91
SN75369	7-75	SN75479	4-91
SN75370	7-81	SN75480	9-13
SN75375	7-99	SN75481	9-17
SN75401	4-17	SN75490	9-21
SN75402	4-17	SN75491	9-25
SN75403	4-17	SN75491A	9-25
SN75404	4-17	SN75492	9-25
SN75411	4-21	SN75492A	9-25
SN75412	4-21	SN75493	9-33
SN75413	4-21	SN75494	9-33
SN75414	4-21	SN75496	9-37
SN75416	4-25	SN75496A	9-37
SN75417	4-25	SN75497	9-39
SN75418	4-25	SN75498	9-39
SN75419	4-25	SN75500A	9-43
SN55426B	9-9	SN75501A	9-47
SN55427B	9-9	SN75502A	9-43
SN75430	4-29	SN75503A	9-47
SN75431	4-29	SN75510	9-51
SN75432	4-29	SN75511	9-55
SN75433	4-29	SN75580	9-59
SN75434	4-29	SN75584A	9-65
SN75437	4-39	uA9636AC	5-251
SN75441	4-43	uA9637AC	5-255
SN75446	4-47	uA9638C	5-258
SN75447	4-47	UDN2841	4-95
SN75448	4-47	UDN2845	4-95
SN75449	4-47	ULN2001A	4-97
SN55450B	4-51	ULN2002A	4-97
SN55451B	4-51	ULN2003A	4-97
SN55452B	4-51	ULN2004A	4-97
SN55453B	4-51	ULN2005A	4-97
SN55454B	4-51	ULN2064	4-105
SN55460	4-63	ULN2065	4-105
SN55461	4-63	ULN2066	4-105
SN55462	4-63	ULN2067	4-105
SN55463	4-63	ULN2068	4-109
SN55464	4-63	ULN2069	4-109
SN75465	4-73	ULN2074	4-113
SN75466	4-73	ULN2075	4-113

## INTERFACE CIRCUITS INTERCHANGEABILITY GUIDE (MANUFACTURERS ARRANGED ALPHABETICALLY)

Direct replacements were based on similarity of electrical and mechanical characteristics as shown in currently published data. Interchangeability in particular applications is not guaranteed. Before using a device as a substitute, the user should compare the specifications of the substitute device with the specifications of the original.

Texas Instruments makes no warranty as to the information furnished and buyer assumes all risk in the use thereof. No liability is assumed for damages resulting from the use of the information contained in this list.

### ADVANCED MICRO DEVICES

#### EXAMPLE OF NOMENCLATURE

AM  
Prefix

75325  
Device Type

N
Package Type
N = Plastic DIP (second source designation for TI Plastic DIP)
P = Plastic DIP
J = Ceramic DIP (second source designation for TI Ceramic DIP)
D = Ceramic DIP

AMD	TI DIRECT REPLACEMENT	TI CLOSEST REPLACEMENT	AMD	TI DIRECT REPLACEMENT	TI CLOSEST REPLACEMENT
AM0026C		SN75369	AM8832	DS8832	
AM1488	SN75188		AM8T26A		SN75136
AM1489	SN75189		AM9614C	SN75114	
AM1489A	SN75189A		AM9614M	SN55114	
AM26LS31C	AM26LS31C		AM9615C	SN75115	
AM26LS32C	AM26LS32AC		AM9615M	SN55115	
AM26LS33C	AM26LS33AC		AM55107B	SN55107B	
AM26S10C	AM26S10C		AM55108B	SN55108B	
AM26S10M	AM26S10M		AM55109	SN55109A	
AM26S11C	AM26S11C		AM55110	SN55110A	
AM26S11M	AM26S11M		AM55234	SN55234	
AM5520	SN5520		AM55235	SN55234	
AM5521	SN5520		AM55238	SN55238	
AM5524	SN5524		AM55239	SN55238	
AM5525	SN5524		AM55325	SN55325	
AM7520	SN7520		AM75107B	SN75107B	
AM7521	SN7520		AM75108B	SN75108B	
AM7524	SN7524		AM75109	SN75109A	
AM7525	SN7524		AM75110	SN75110A	
AM7820A	SN55182		AM75207	SN75207	
AM7830	SN55183		AM75208	SN75208	
AM7831	DS7831		AM75234	SN75234	
AM7832	DS7832		AM75235	SN75234	
AM8820A	SN75182		AM75238	SN75238	
AM8830	SN75183		AM75239	SN75238	
AM8831	DS8831		AM75325	SN75325	

# FAIRCHILD

## EXAMPLE OF NOMENCLATURE

75450B  
Device Type

D
Package Type
D = Ceramic DIP
P = Plastic DIP
R = Ceramic Mini DIP
T = Plastic Mini DIP
H = Metal Can
F = Flat Package

C
Temperature Range
C = Commercial
0°C to 70°C or 75°C
M = Military
-55°C to 125°C

FAIRCHILD	TI DIRECT REPLACEMENT	TI CLOSEST REPLACEMENT	FAIRCHILD	TI DIRECT REPLACEMENT	TI CLOSEST REPLACEMENT
μA8T13M	SN55121		9626C		SN75136
μA8T13C	SN75121		9627C		SN75152
μA8T14M	SN55122		9634C		SN75159
μA8T14C	SN75122		9636AC	μA9636AC	
μA8T23C	SN75123		9637AC	μA9637AC	
μA8T24C	SN75124		9637AM		SN55157
μA1488C	SN75188		9638C	μA9638C	
μA1489C	SN75189		9638M		SN55158
μA1489AC	SN75189A		9640C	AM26S10C	
5524M	SN5524		9640M	AM26S10M	
5525M	SN5524		9641C	AM26S11C	
5528M	SN5528		9641M	AM26S11M	
5529M	SN5528		9643		{ SN75322
5534M		SN55232	9644C		{ SN75363
5535M		SN55232	9664C		{ SN75361A
5538M		SN55238	9665AC	SN75492	
5539M		SN55238	9665AC	SN75466	
7524C	SN7524		9665C	ULN2001A	
7525C	SN7524		9666AC	SN75467	
7528C	SN7528		9666C	ULN2002A	
7529C	SN7528		9667AC	SN75468	
7534C		SN75232	9667C	ULN2003A	
7535C		SN75232	9668AC	SN75469	
7538C		SN75238	9668C	ULN2004A	
7539C		SN75238	55107AM	SN55107A	
9612C		SN75158	55107BM	SN55107B	
9614M	SN55114		55108AM	SN55108A	
9614C	SN75114		55108BM	SN55108B	
9615M	SN55115		55109M	SN55109A	
9615C	SN75115		55110M	SN55110A	
9616C		{ SN75188	55121M	SN55121	
		{ SN75150	55122M	SN55122	
		{ SN75152			
		{ SN75154			
9617C		{ SN75189			
		{ SN75189A			

FAIRCHILD	TI DIRECT REPLACEMENT	TI CLOSEST REPLACEMENT	FAIRCHILD	TI DIRECT REPLACEMENT	TI CLOSEST REPLACEMENT
55224M		SN55234	75154C	SN75154	
55225M		SN55234	75207C	SN75207	
55232M	SN55232		75208C	SN75208	
55233M	SN55232		75224C		SN75234
55234M	SN55234		75225C		SN75234
55235M	SN55234		75232C	SN75232	
55238M	SN55238		75233C	SN75232	
55239M	SN55238		75234C	SN75234	
55325M	SN55325		75235C	SN75234	
55326M	SN55326		75238C	SN75238	
55327M	SN55327		75239C	SN75238	
55450AM	SN55450B		75325C	SN75325	
55450BM	SN55450B		75326C	SN75326	
55451AM	SN55451B		75327C	SN75327	
55451BM	SN55451B		75430C	SN75430	
55452AM	SN55452B		75431C	SN75431	
55452BM	SN55452B		75432C	SN75432	
55453AM	SN55453B		75433C	SN75433	
55453BM	SN55453B		75434C	SN75434	
55454AM	SN55454B		75450AC	SN75450B	
55454BM	SN55454B		75450BC	SN75450B	
55460M	SN55460		75451AC	SN75451B	
55461M	SN55461		75451BC	SN75451B	
55462M	SN55462		75452AC	SN75452B	
55463M	SN55463		75452BC	SN75452B	
55464M	SN55464		75453AC	SN75453B	
55470M	SN55470		75453BC	SN75453B	
55471M	SN55471		75454AC	SN75454B	
55472M	SN55472		75454BC	SN75454B	
55473M	SN55473		75460C	SN75460	
55474M	SN55474		75461C	SN75461	
75107AC	SN75107A		75462C	SN75462	
75107BC	SN75107B		75463C	SN75463	
75108AC	SN75108A		75464C	SN75464	
75108BC	SN75108B		75470C	SN75470	
75109C	SN75109A		75471C	SN75471	
75110C	SN75110A		75472C	SN75472	
75112C	SN75112		75473C	SN75473	
75121C	SN75121		75474C	SN75474	
75122C	SN75122		75491C	SN75491	
75123C	SN75123		75491AC	SN75491A	
75124C	SN75124		75492C	SN75492	
75150C	SN75150		75492AC	SN75492A	

# ITT

## EXAMPLE OF NOMENCLATURE

ITT  
Prefix

75450  
Device Type

-5
Temperature Range
-1 = -55° C to 125° C
-5 = 0° C to 70° C

D
Package
D = Ceramic DIP
N = Plastic DIP

ITT	TI DIRECT REPLACEMENT	TI CLOSEST REPLACEMENT
ITT491	SN75491	
ITT492	SN75492	
ITT493	SN75493	
ITT494	SN75494	
ITT1488	SN75188	
ITT1489	SN75189	
ITT1489A	SN75189A	
ITT5520	SN5520	
ITT5521	SN5520	
ITT5522	SN5522	
ITT5523	SN5522	
ITT5524	SN5524	
ITT5525	SN5524	
ITT5528	SN5528	
ITT5529	SN5528	
ITT5534		SN55232
ITT5535		SN55232
ITT7520	SN7520	
ITT7521	SN7520	
ITT7522	SN7522	
ITT7523	SN7522	
ITT7524	SN7524	
ITT7525	SN7524	
ITT7528	SN7528	
ITT7529	SN7528	
ITT7534		SN75232
ITT7535		SN75232
ITT9614	SN75114	
ITT9615	SN75115	
ITT55107A	SN55107A	
ITT55107B	SN55107B	
ITT55108A	SN55108A	
ITT55108B	SN55108B	
ITT55109	SN55109A	
ITT55110	SN55110A	
ITT55138	SN55138	
ITT55234	SN55234	
ITT55235	SN55234	

ITT	TI DIRECT REPLACEMENT	TI CLOSEST REPLACEMENT
ITT55324	SN55324	
ITT55325	SN55325	
ITT55450	SN55450B	
ITT55451	SN55451B	
ITT55452	SN55452B	
ITT55453	SN55453B	
ITT55454	SN55454B	
ITT55460	SN55460	
ITT55461	SN55461	
ITT55462	SN55462	
ITT55463	SN55463	
ITT55464	SN55464	
ITT75107A	SN75107A	
ITT75107B	SN75107B	
ITT75108A	SN75108A	
ITT75108B	SN75108B	
ITT75109	SN75109A	
ITT75110	SN75110A	
ITT75138	SN75138	
ITT75207	SN75207	
ITT75208	SN75208	
ITT75234	SN75234	
ITT75235	SN75234	
ITT75322	SN75322	
ITT75324	SN75324	
ITT75325	SN75325	
ITT75450	SN75450B	
ITT75451	SN75451B	
ITT75452	SN75452B	
ITT75453	SN75453B	
ITT75454	SN75454B	
ITT75460	SN75460	
ITT75461	SN75461	
ITT75462	SN75462	
ITT75463	SN75463	
ITT75464	SN75464	
ITT9614	SN75114	
ITT9615	SN75115	

# MOTOROLA

1

## EXAMPLE OF NOMENCLATURE

MC  
Prefix

75325  
Device Type

P
Package
P = Plastic DIP
L = Ceramic DIP
G = Metal Can
F = Flat Package

MOTOROLA	TI DIRECT REPLACEMENT	TI CLOSEST REPLACEMENT	MOTOROLA	TI DIRECT REPLACEMENT	TI CLOSEST REPLACEMENT
MMH0026C		SN75369	MC7523	SN7522	
MC8T13	SN75121		MC7524	SN7524	
MC8T14	SN75122		MC7525	SN7524	
MC8T23	SN75123		MC7528	SN7528	
MC8T24	SN75124		MC7529	SN7528	
MC8T26		SN75136	MC7534		SN75232
MC1411	ULN2001A		MC7535		SN75232
MC1412	ULN2002A		MC7538		SN75238
MC1413	ULN2003A		MC7539		SN75238
MC1416	ULN2004A		MC55107	SN55107A	
MC1488	SN75188		MC55108	SN55108A	
MC1489	SN75189		MC55325	SN55325	
MC1489A	SN75189A		MC75107	SN75107A	
MC26S10	AM26S10C		MC75108	SN75108A	
MC26S11	AM26S11C		MC75109	SN75109A	
MC3443		SN75138	MC75110	SN75110A	
MC3446	MC3446		MC75140	SN75140	
MC3447		SN75160A	MC75325	SN75325	
MC3453		SN75110A	MC75358	SN75368	
MC3481	SN75126		MC75365	SN75365	
MC3485	SN75130		MC75368	SN75368	
MC3486	MC3486		MC75450	SN75450B	
MC3487	MC3487		MC75451	SN75451B	
MC5522	SN5522		MC75452	SN75452B	
MC5523	SN5522		MC75453	SN75453B	
MC5524	SN5524		MC75454	SN75454B	
MC5525	SN5524		MC75460	SN75460	
MC5528	SN5528		MC75461	SN75461	
MC5529	SN5528		MC75462	SN75462	
MC5534		SN55232	MC75463	SN75463	
MC5535		SN55232	MC75464	SN75464	
MC5538		SN55238	MC75491	SN75491	
MC5539		SN55238	MC75492	SN75492	
MC7522	SN7522				



# NATIONAL

## EXAMPLE OF NOMENCLATURE

DS  
Prefix

75325  
Device Type

N  
Package  
N = Plastic DIP  
J = Ceramic DIP  
W = Flat Package  
H = Metal Can

NATIONAL	TI DIRECT REPLACEMENT	TI CLOSEST REPLACEMENT	NATIONAL	TI DIRECT REPLACEMENT	TI CLOSEST REPLACEMENT
DS0026C		SN75369	DS5539		SN55238
DS1488	SN75188		DS7520	SN7520	
DS1489	SN75189		DS7520A		SN7520
DS1489A	SN75189A		DS7521	SN7520	
DS1611		SN55471	DS7522	SN7522	
DS1612		SN55472	DS7522A		SN7522
DS1613		SN55473	DS7523	SN7522	
DS1614		SN55474	DS7524	SN7524	
DS26LS31	AM26LS31C		DS7524A		SN7524
DS26LS32	AM26LS32AC		DS7525	SN7524	
DS26S10C	AM26S10C		DS7528	SN7528	
DS26S10M	AM26S10M		DS7528A		SN7528
DS26S11C	AM26S11C		DS7529	SN7528	
DS26S11M	AM26S11M		DS7534		SN75232
DS3486	MC3486		DS7534A		SN75232
DS3487	MC3487		DS7535		SN75232
DS3611		SN75471	DS7538		SN75238
DS3612		SN75472	DS7538A		SN75238
DS3613		SN75473	DS7539		SN75238
DS3614		SN75474	DS7800	SN55180	
DS3629		SN75324	DS7820	SN55182	
DS5520	SN5520		DS7820A	SN55182	
DS5520A		SN5520	DS7830	SN55183	
DS5521	SN5520		DS7831	DS7831	
DS5522	SN5522		DS7832	DS7832	
DS5522A		SN5522	DS8T26A	NBT26A	
DS5523	SN5522		DS88LS20		SN75182
DS5524	SN5524		DS8820	SN75182	
DS5524A		SN5524	DS8820A	SN75182	
DS5525	SN5524		DS8830	SN75183	
DS5528	SN5528		DS8831	DS8831	
DS5528A		SN5528	DS8832	DS8832	
DS5529	SN5528		DS8880	SN75480	
DS5534		SN55232	DS55107	SN55107B	
DS5534A		SN55232	DS55108	SN55108B	
DS5535		SN55232	DS55109	SN55109A	
DS5538		SN55238	DS55110	SN55110A	
DS5538A		SN55238			

1

NATIONAL	TI DIRECT REPLACEMENT	TI CLOSEST REPLACEMENT
DS55113	SN55113	
DS55114	SN55114	
DS55115	SN55115	
DS55121	SN55121	
DS55122	SN55122	
DS55325	SN55325	
DS55450	SN55450B	
DS55451	SN55451B	
DS55452	SN55452B	
DS55453	SN55453B	
DS55454	SN55454B	
DS55460	SN55460	
DS55461	SN55461	
DS55462	SN55462	
DS55463	SN55463	
DS55464	SN55464	
DS75107	SN75107B	
DS75108	SN75108B	
DS75109	SN75109A	
DS75110	SN75110A	
DS75113	SN75113	
DS75114	SN75114	
DS75115	SN75115	
DS75121	SN75121	
DS75122	SN75122	
DS75123	SN75123	
DS75124	SN75124	

NATIONAL	TI DIRECT REPLACEMENT	TI CLOSEST REPLACEMENT
DS75150	SN75150	
DS75154	SN75154	
DS75207	SN75207B	
DS75208	SN75208B	
DS75322	SN75322	
DS75324	SN75324	
DS75325	SN75325	
DS75361	SN75361A	
DS75362		SN75365
DS75364	SN75364	
DS75365	SN75365	
DS75450	SN75450B	
DS75451	SN75451B	
DS75452	SN75452B	
DS75453	SN75453B	
DS75454	SN75454B	
DS75460	SN75460	
DS75461	SN75461	
DS75462	SN75462	
DS75463	SN75463	
DS75464	SN75464	
DS75491	SN75491	
DS75492	SN75492	
DS75493	SN75493	
DS75494	SN75494	
DS78LS20		SN55182
DS88LS20		SN75182

## SIGNETICS

### EXAMPLE OF NOMENCLATURE

**75454B**  
Device Type

**V**  
Package  
A = 14 pin Plastic DIP  
FH = 14 pin Ceramic DIP  
V = 8 pin Plastic DIP  
T = 8 pin Metal Can  
B = 16 pin Plastic DIP  
FJ = 16 pin Ceramic DIP

SIGNETICS	TI DIRECT REPLACEMENT	TI CLOSEST REPLACEMENT
N8T13	SN75121	
N8T14	SN75122	
N8T15		SN75150
N8T16		SN75152
N8T23	SN75123	
N8T24	SN75124	
N8T26	N8T26	
N8T26A	N8T26A	
S8T13	SN55121	
S8T14	SN55122	55454B
DM7820	SN55182	
DM7830	SN55183	
DM8820	SN75182	
DM8830	SN75183	
DM8880	SN75480	
MC1488	SN75188	
MC1489	SN75189	
MC1489A	SN75189A	
3207A		SN75365
3207A-1		SN75365
7520	SN7520	
7521	SN7520	

SIGNETICS	TI DIRECT REPLACEMENT	TI CLOSEST REPLACEMENT
7522	SN7522	
7523	SN7522	
7524	SN7524	
7525	SN7524	
55325	SN55325	
55450B	SN55450B	
55451B	SN55451B	
55452B	SN55452B	
55453B	SN55453B	
55454B	SN55454B	
75S107		SN75107A
75S108		SN75108A
75S207		SN75207
75S208		SN75208
75324	SN75324	
75325	SN75325	
75361A	SN75361A	
75450B	SN75450B	
75451B	SN75451B	
75452B	SN75452B	
75453B	SN75453B	
75454B	SN75454B	

## SPRAGUE

### EXAMPLE OF NOMENCLATURE:

**ULN**  
Prefix

**2068**  
Type Number

**B**  
Package  
A = Plastic DIP (N designation for TI)  
B = Plastic DIP with heatsink lead frame  
(NE designation for TI)  
M = Plastic mini-DIP (P designation for TI)  
J = Ceramic DIP (TI designation)

SPRAGUE	TI DIRECT REPLACEMENT	TI CLOSEST REPLACEMENT
UDN2841	UDN2841	
UDN2845	UDN2845	
UDN3611	SN75471	
UDN3612	SN74572	
UDN3613	SN75473	
UDN3614	SN75474	
UDN5711	SN75476	
UDN5712	SN75477	
UDN5713	SN75478	
UDN5714	SN75479	
ULN2001A	ULN2001A	
ULN2002A	ULN2002A	

SPRAGUE	TI DIRECT REPLACEMENT	TI CLOSEST REPLACEMENT
ULN2003A	ULN2003A	
ULN2004A	ULN2004A	
ULN2005A	ULN2005A	
ULN2064	ULN2064	
ULN2065	ULN2065	
ULN2066	ULN2066	
ULN2067	ULN2067	
ULN2068	ULN2068	
ULN2069	ULN2069	
ULN2074	ULN2074	
ULN2075	ULN2075	



# Thermal Information





# THERMAL INFORMATION

## THERMAL RESISTANCE

PACKAGE	PINS	JUNCTION-TO-CASE THERMAL RESISTANCE $R_{\theta JC}$ ( $^{\circ}C/W$ )	JUNCTION-TO-AMBIENT THERMAL RESISTANCE $R_{\theta JA}$ ( $^{\circ}C/W$ )
J ceramic dual-in-line (glass-mounted chips)	14 thru 20	60	122
J ceramic dual-in-line† (alloy-mounted chips)	14 thru 20	29†	91†
JG ceramic dual-in-line (glass-mounted chips)	8	58	151
JG ceramic dual-in-line† (alloy-mounted chips)	8	26†	119†
N plastic dual-in-line	14 thru 20	44	108
	22	39	94
NE plastic dual-in-line	14, 16	10	60
P plastic dual-in-line	8	45	125
W ceramic flat package	14		125

† In addition to those products so designated on their data sheets, all devices having a type number prefix of "SNC" or "SNM," or a suffix of "/883" have alloy-mounted chips.

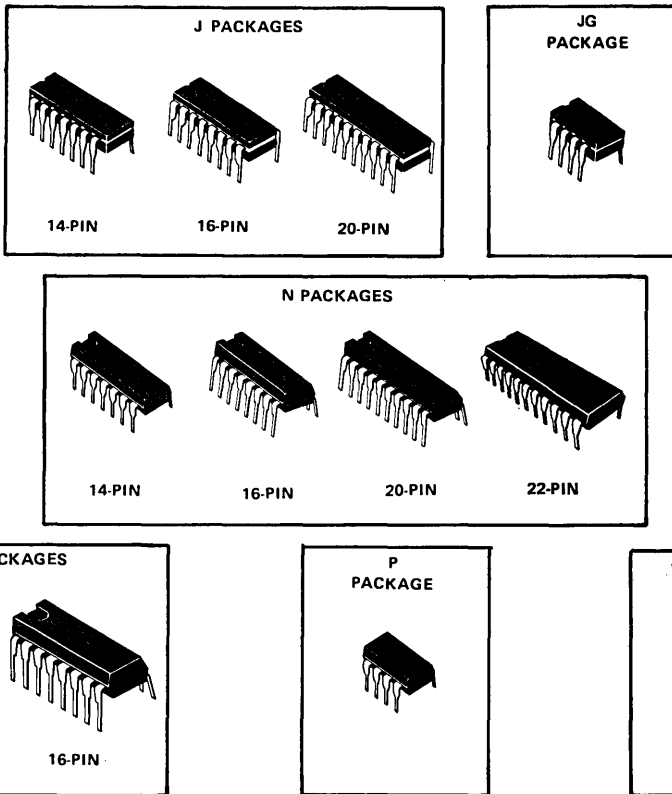

TEXAS INSTRUMENTS  
INCORPORATED

POST OFFICE BOX 225012 • DALLAS, TEXAS 75265

# THERMAL INFORMATION

## CERAMIC DUAL-IN-LINE PACKAGES

These curves are for use with the continuous dissipation ratings specified on the individual data sheets. Those ratings apply up to the temperature at which the rated level intersects the appropriate derating curve or the maximum operating free-air temperature.

DISSIPATION DERATING CURVE

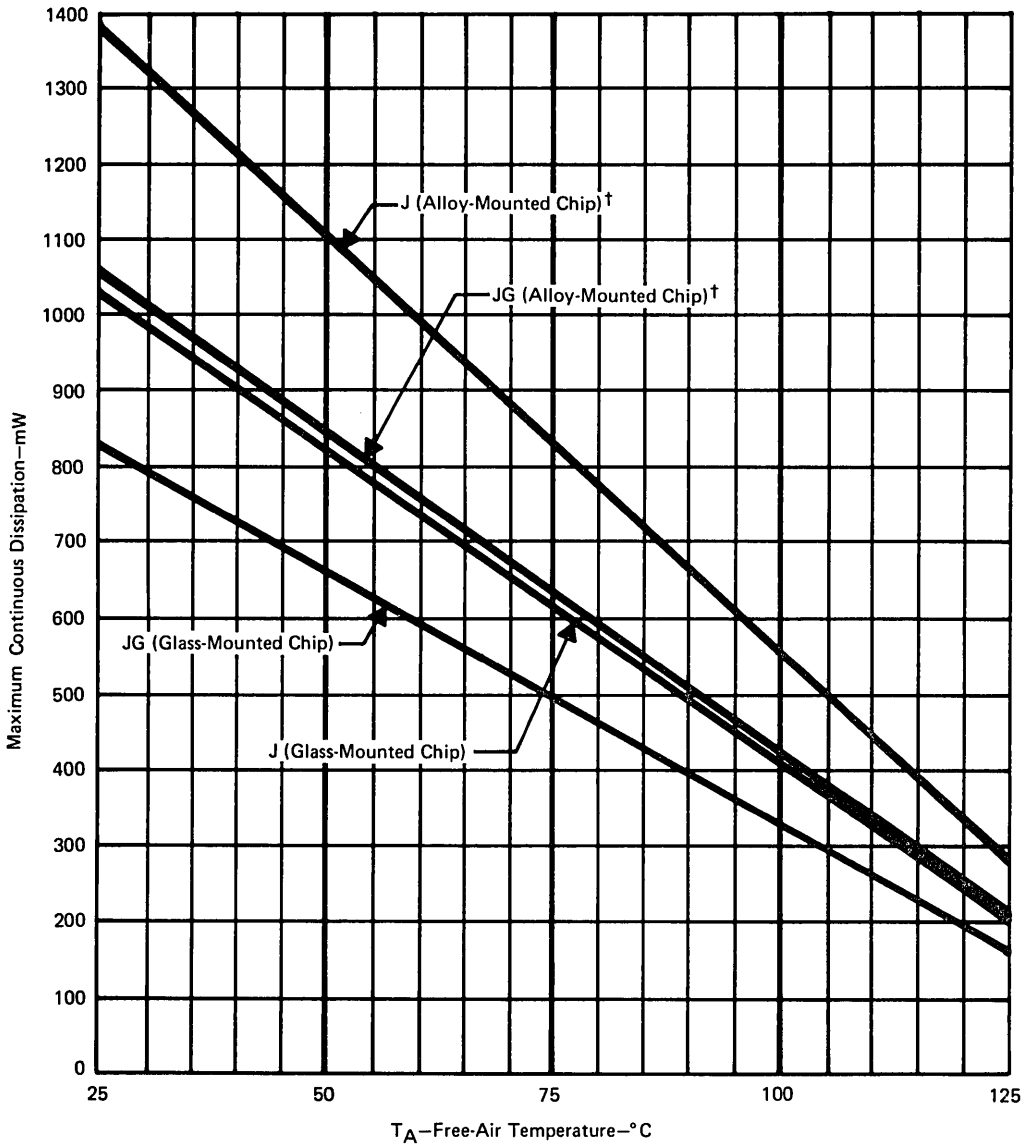

† In addition to those products so designated on their data sheets, all devices having a type number prefix of "SNC" or "SNM", or a suffix of "/883" have alloy-mounted chips.

# THERMAL INFORMATION

## PLASTIC DUAL-IN-LINE PACKAGES

These curves are for use with the continuous dissipation ratings specified on the individual data sheets. Those ratings apply up to the temperature at which the rated level intersects the appropriate derating curve or the maximum operating free-air temperature.

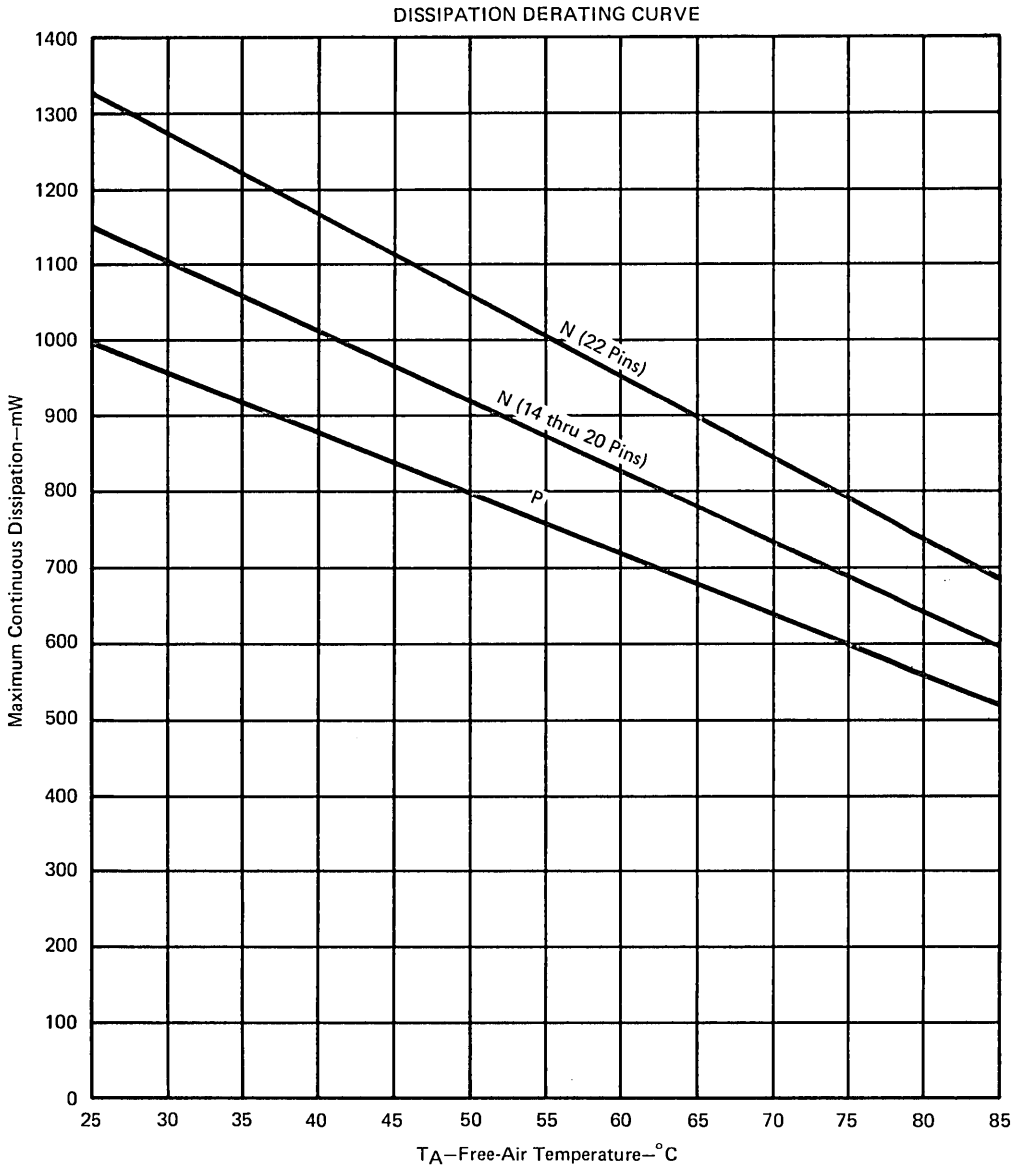

**TEXAS INSTRUMENTS**  
INCORPORATED

POST OFFICE BOX 225012 • DALLAS, TEXAS 75265

# THERMAL INFORMATION

## PLASTIC MEDIUM-POWER DUAL-IN-LINE PACKAGE

These curves are for use with the continuous dissipation ratings specified on the individual data sheets. Those ratings apply up to the temperature at which the rated level intersects the appropriate derating curve or the maximum operating free-air temperature.

2

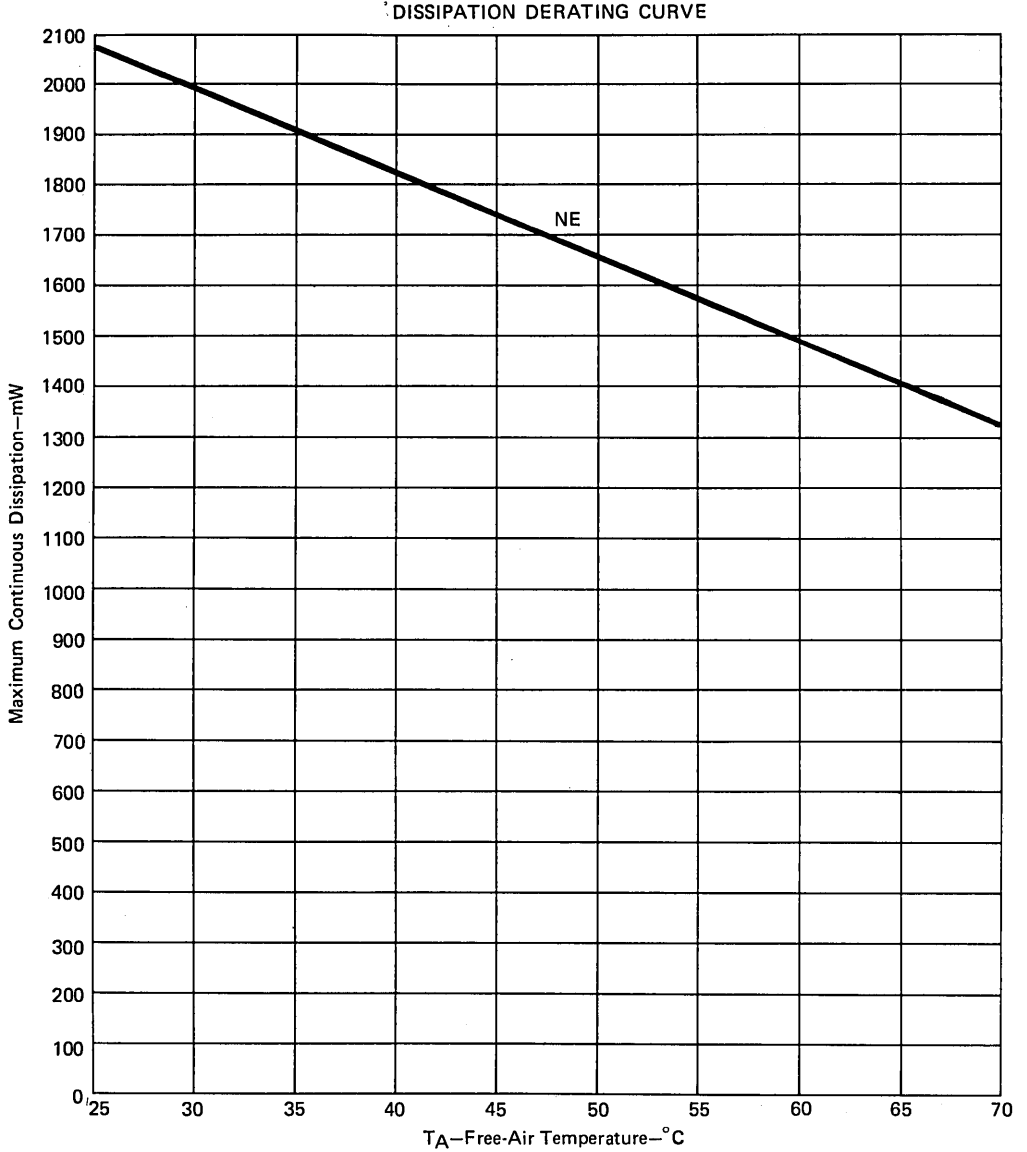

# THERMAL INFORMATION

## CERAMIC FLAT PACKAGES

These curves are for use with the continuous dissipation ratings specified on the individual data sheets. Those ratings apply up to the temperature at which the rated level intersects the appropriate derating curve or the maximum operating free-air temperature.

DISSIPATION DERATING CURVE

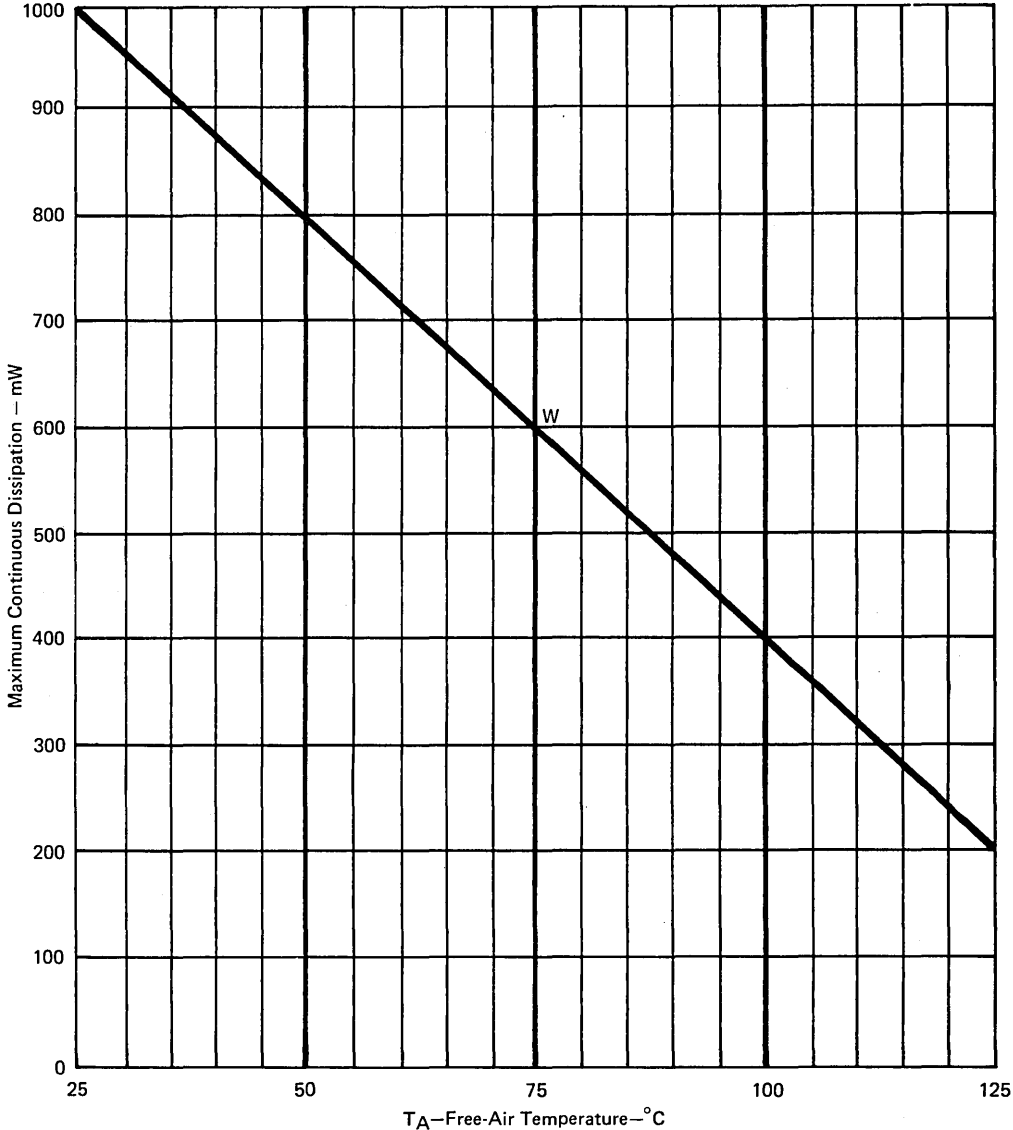

2





# **Ordering Instructions and Mechanical Data**



# ORDERING INSTRUCTIONS AND MECHANICAL DATA

## ORDERING INSTRUCTIONS

Electrical characteristics presented in this data book apply for the circuit type(s) listed in the page heading, unless otherwise noted, regardless of package. The availability of a circuit function in a particular package is indicated by an alphabetical reference above the pin-connection diagram(s). These alphabetical references refer to mechanical outline drawings shown in this section.

Factory orders for circuits described in this data book should include a three-part type number as explained in the following example.

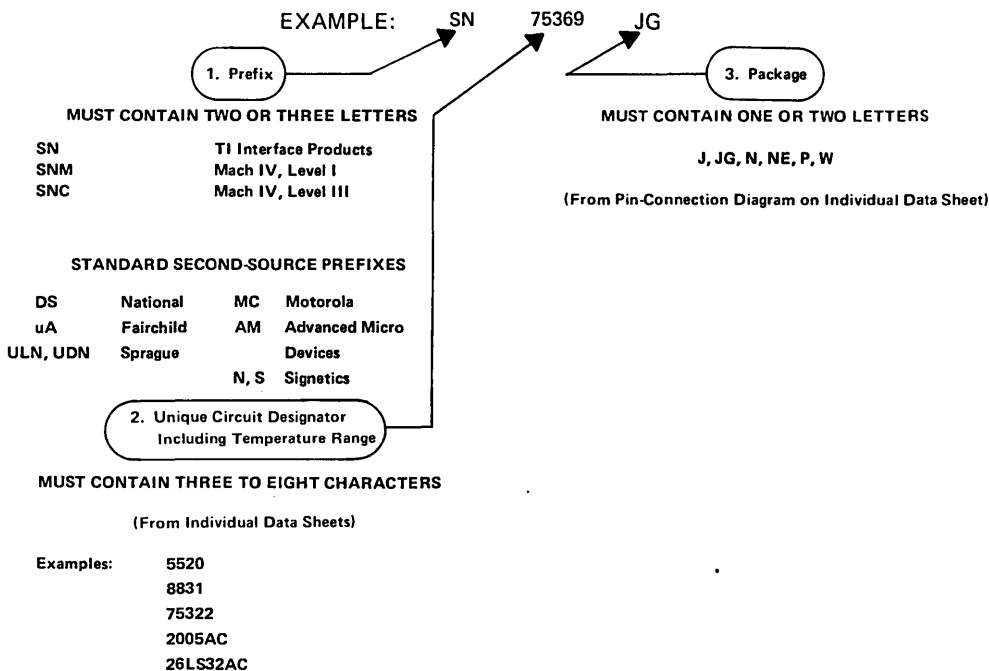

3

Circuits are shipped in one of the carriers shown below. Unless a specific method of shipment is specified by the customer (with possible additional costs), circuits will be shipped in the most practical carrier.

- Slide Magazines
- A-Channel Plastic Tubing
- Barnes Carrier
- Sectioned Cardboard Box
- Individual Plastic Box

TEXAS INSTRUMENTS  
INCORPORATED

POST OFFICE BOX 225012 • DALLAS, TEXAS 75265

3-3

# ORDERING INSTRUCTIONS AND MECHANICAL DATA

## J ceramic dual-in-line packages

These hermetically sealed dual-in-line packages consist of a ceramic base, ceramic cap, and a 14-, 16-, or 20-lead frame. Hermetic sealing is accomplished with glass. The packages are intended for insertion in mounting-hole rows on 0.300 (7,62) centers (see Note a). Once the leads are compressed and inserted, sufficient tension is provided to secure the package in the board during soldering. Tin-plated ("bright-dipped") leads require no additional cleaning or processing when used in soldered assembly.

3

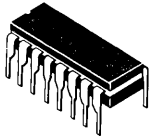
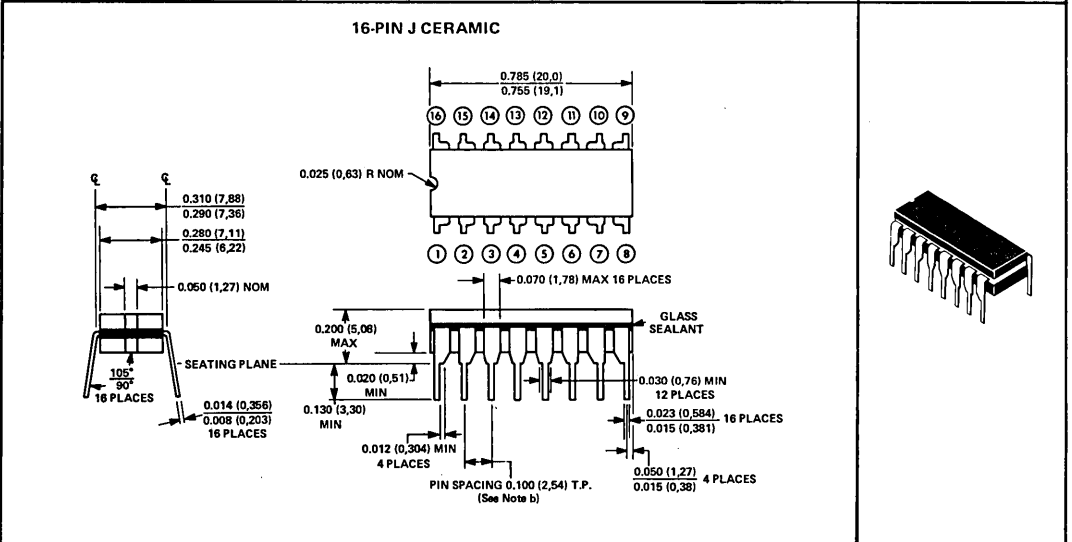
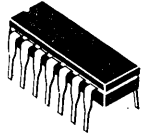
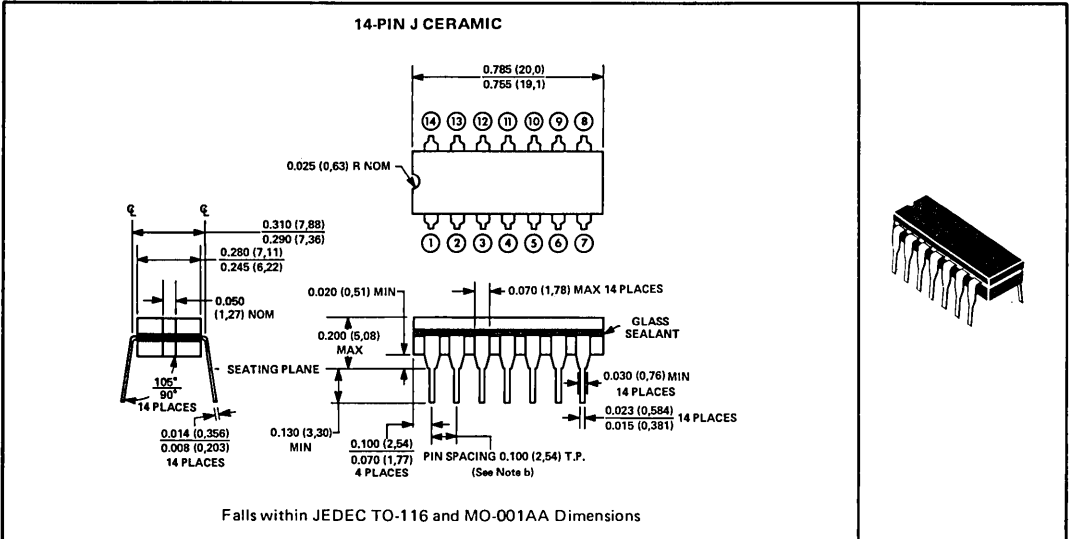

NOTES: a. All dimensions are in inches and parenthetically in millimeters. Inch dimensions govern.  
 b. Each pin centerline is located within 0.010 (0,26) of its true longitudinal position.

# ORDERING INSTRUCTIONS AND MECHANICAL DATA

## J ceramic dual-in-line packages (continued)

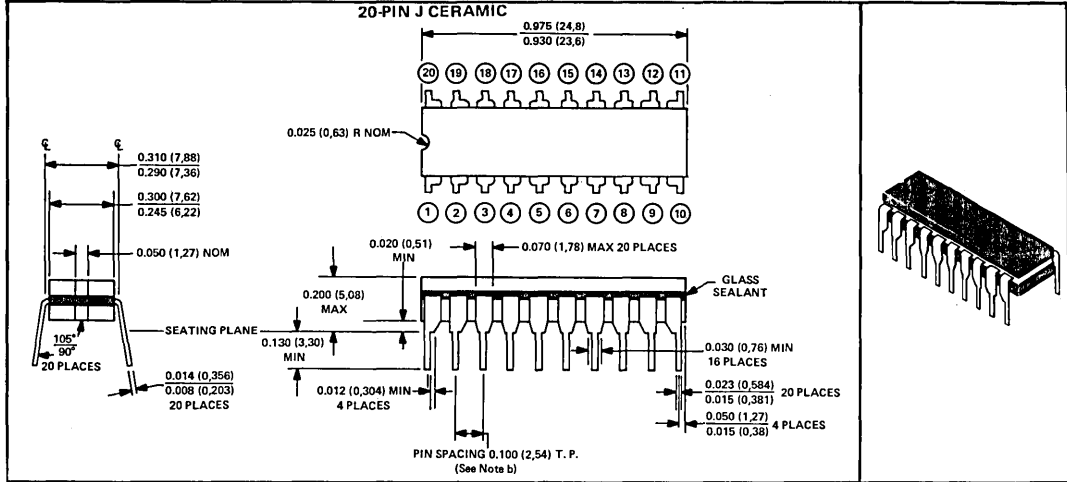

## JG ceramic dual-in-line package

This hermetically sealed dual-in-line package consists of a ceramic base, ceramic cap, and 8-lead frame. Hermetic sealing is accomplished with glass. The package is intended for insertion in mounting-hole rows on 0.300 (7,62) centers (see Note a). Once the leads are compressed and inserted, sufficient tension is provided to secure the package in the board during soldering. Tin-plated ("bright-dipped") leads require no additional cleaning or processing when used in soldered assembly.

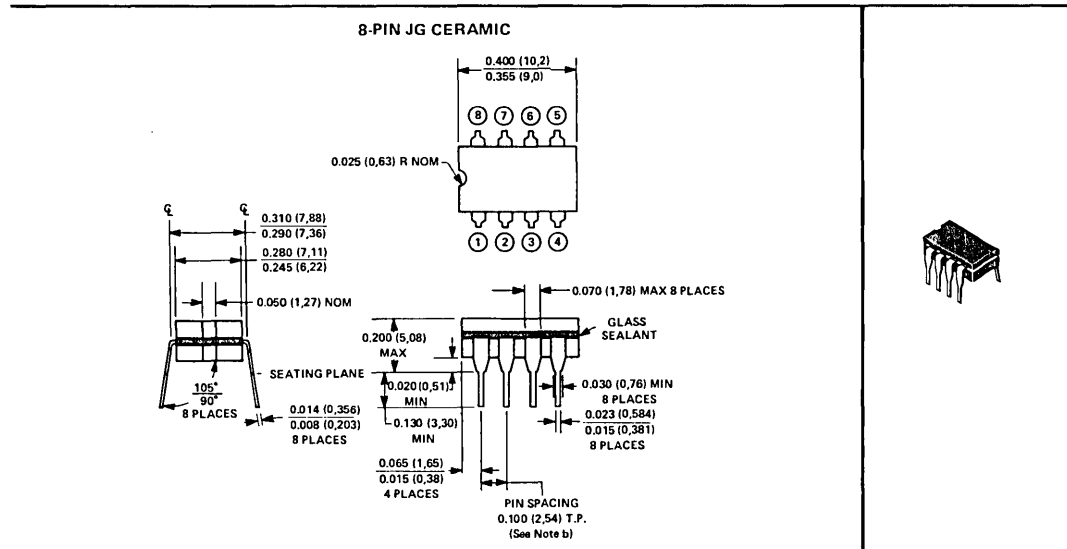

- NOTES: a. All dimensions are in inches and parenthetically in millimeters. Inch dimensions govern.  
b. Each pin centerline is located within 0.010 (0,26) of its true longitudinal position.

# ORDERING INSTRUCTIONS AND MECHANICAL DATA

## N and NE plastic dual-in-line packages

These dual-in-line packages consist of a circuit mounted on a 14- or 16-lead frame and encapsulated within an electrically nonconductive plastic compound. The compound will withstand soldering temperature with no deformation and circuit performance characteristics remain stable when operated in high-humidity conditions. The packages are intended for insertion in mounting-hole rows on 0.300 (7,62) centers (see Note a). Once the leads are compressed and inserted, sufficient tension is provided to secure the package in the board during soldering. Leads require no additional cleaning or processing when used in soldered assembly. The NE package has internal metal tabs connecting the two or three central leads on each side for better heat dissipation.

### 14-PIN N AND NE PLASTIC

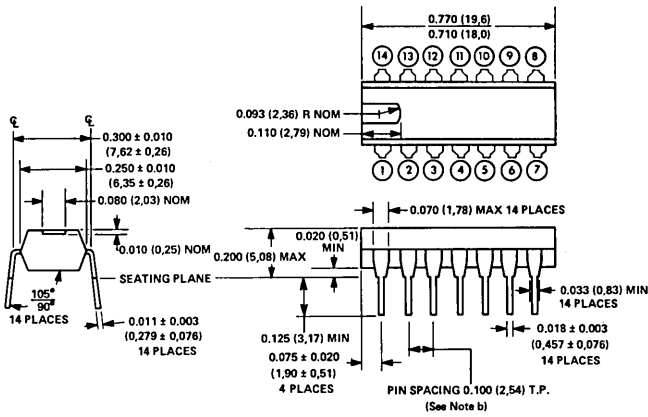

Falls Within JEDEC TO-116 and MO-001AA Dimensions

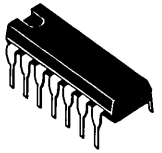

### 16-PIN N AND NE PLASTIC

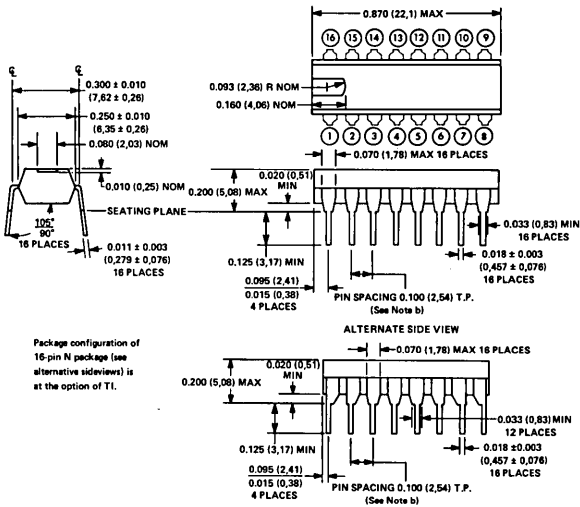

Package configuration of 16-pin N package (see alternative sideviews) is at the option of TI.

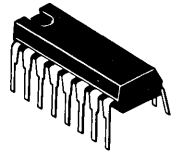

- NOTES: a. All dimensions are in inches and parenthetically in millimeters. Inch dimensions govern.  
b. Each pin centerline is located within 0.010 (0.26) of its true longitudinal position.

# ORDERING INSTRUCTIONS AND MECHANICAL DATA

## N dual-in-line plastic packages (continued)

### 20-PIN N PLASTIC

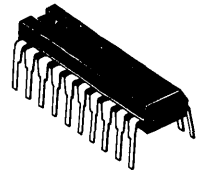
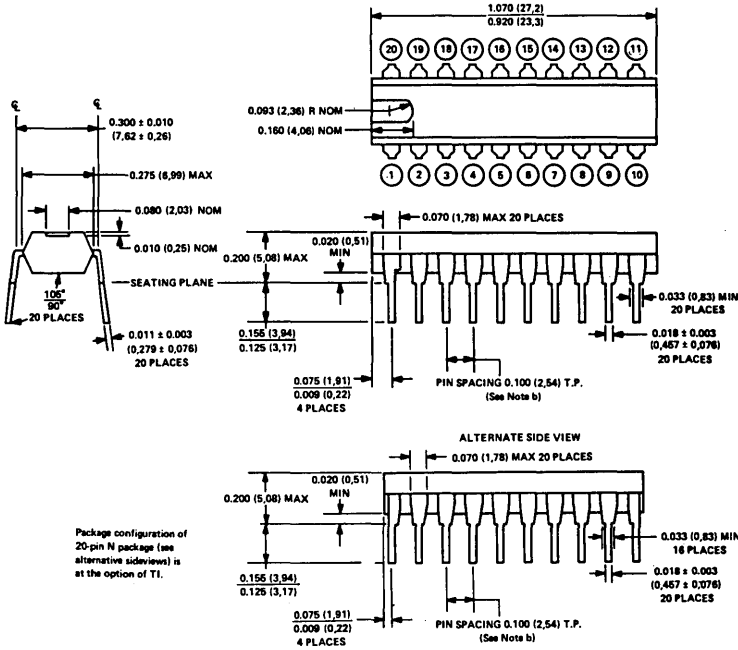

3

### 22-PIN N PLASTIC

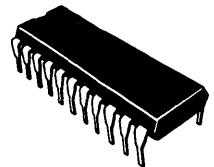
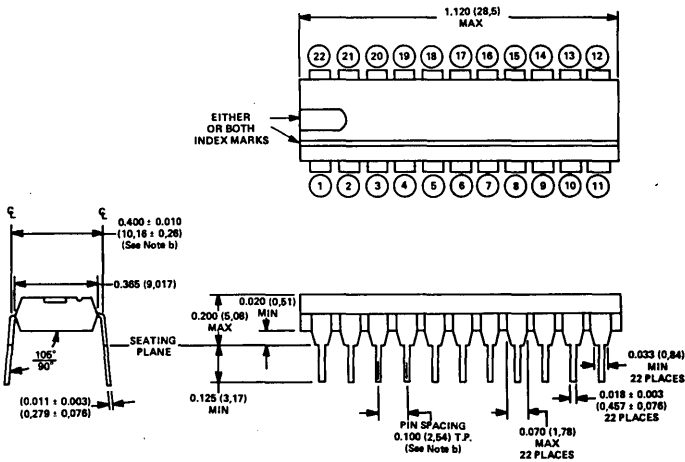

NOTES: a. All dimensions are in inches and parenthetically in millimeters. Inch dimensions govern.  
 b. Each pin centerline is located within 0.010 (0,26) of its true longitudinal position.

**TEXAS INSTRUMENTS**  
 INCORPORATED

POST OFFICE BOX 226012 • DALLAS, TEXAS 75265

# ORDERING INSTRUCTIONS AND MECHANICAL DATA

## P dual-in-line plastic package

This dual-in-line package consists of a circuit mounted on an 8-lead frame and encapsulated in an electrically nonconductive plastic compound. The compound will withstand soldering temperature with no deformation and circuit performance characteristics remain stable when operated under high-humidity conditions. This package is intended for insertion in mounting hole rows on 0.300 (7,62) centers (see Note a). Once the leads are compressed and inserted, sufficient tension is provided to secure the package in the board during soldering. Leads require no additional cleaning or processing when used in soldered assembly.

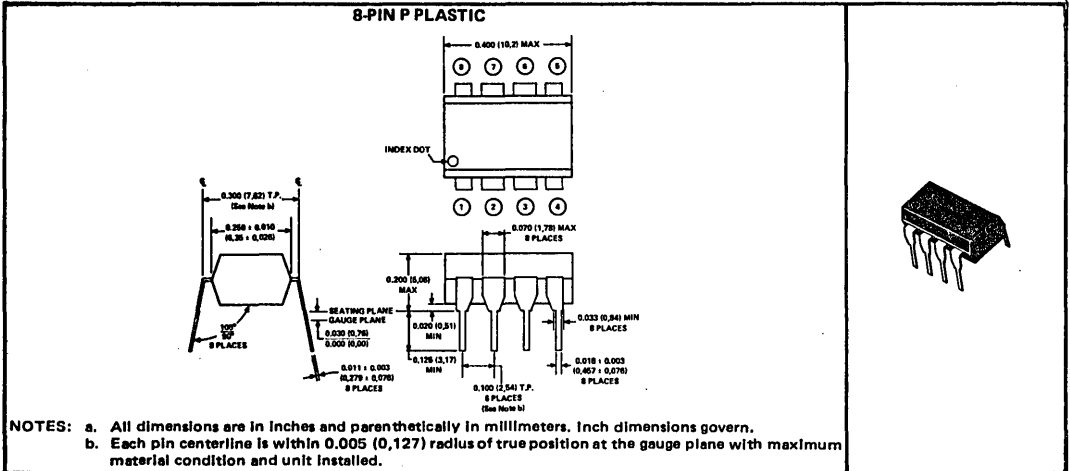

## W ceramic flat package

These hermetically sealed flat packages consist of an electrically nonconductive ceramic base and cap, and a 14-lead frame. Hermetic sealing is accomplished with glass. Tin-plated ("bright-dipped") leads (-00) require an additional cleaning or processing when used in soldered assembly.

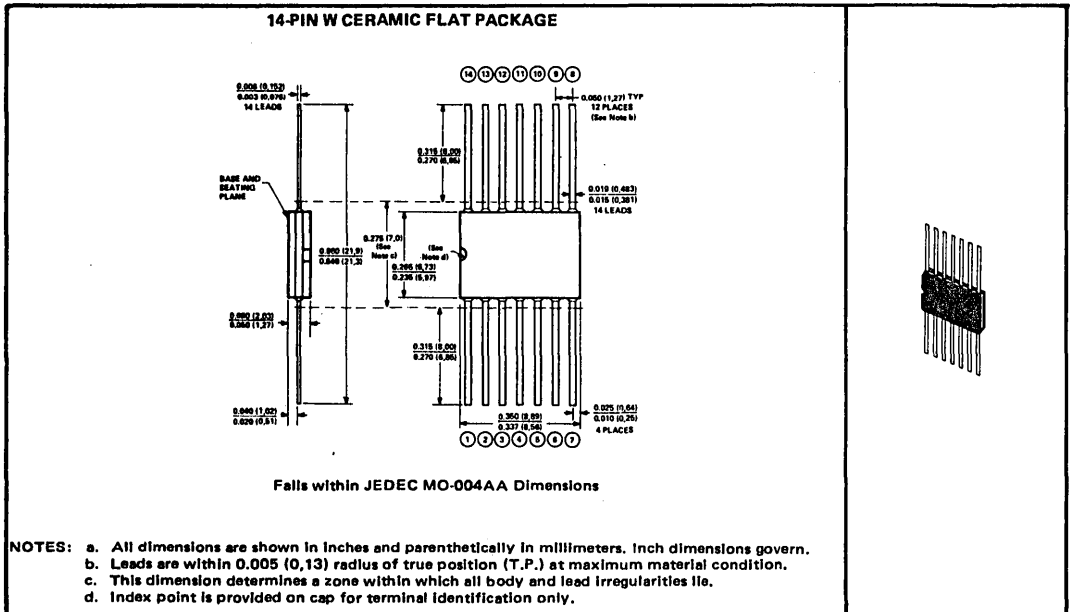

**TEXAS INSTRUMENTS**  
INCORPORATED

POST OFFICE BOX 225012 • DALLAS, TEXAS 75265



# Peripheral Drivers

# PERIPHERAL DRIVER SELECTION GUIDE

## DRIVERS WITH LOGIC GATES

### Military Temperature Range (-55°C to 125°C)

SWITCHING VOLTAGE	MAX RECOMMENDED OUTPUT CURRENT	DRIVERS PER PACKAGE	INTERNAL CLAMP DIODES	LOGIC GATE FUNCTION				PAGE NUMBER
				AND	NAND	OR	NOR	
20 V	300 mA	2	-	SN65450B				4-51
				SN55451B	SN55452B	SN55453B	SN55454B	4-51
30 V	300 mA	2	-	SN55460				4-63
				SN55461	SN55462	SN55463	SN55464	4-63
55 V	300 mA	2	-	SN55470				4-81
				SN55471	SN55472	SN55473	SN55474	4-81

4

### Commercial Temperature Range (0°C to 70°C)

SWITCHING VOLTAGE	MAX RECOMMENDED OUTPUT CURRENT	DRIVERS PER PACKAGE	INTERNAL CLAMP DIODES	LOGIC GATE FUNCTION				PAGE NUMBER
				AND	NAND	OR	NOR	
15 V	300 mA	2	-	SN75430				4-29
				SN75431	SN75432	SN75433	SN75434	4-29
20 V	100 mA	2	-			SN75441		4-43
	300 mA	2	-	SN75450B				4-51
				SN75451B	SN75452B	SN75453B	SN75454B	4-51
	30 V	300 mA	2	-	SN75460			
500 mA		2	-	SN75461	SN75462	SN75463	SN75464	4-63
35 V	500 mA	4	YES	SN75401	SN75402	SN75403	SN75404	4-17
					SN75437			4-39
55 V	300 mA	2	-	SN75470				4-81
			YES	SN75471	SN75472	SN75473	SN75474	4-81
	YES	SN75476	SN75477	SN75478	SN75479	4-91		
	YES	SN75446	SN75447	SN75448	SN75449	4-47		
	500 mA	2	-	SN75411	SN75412	SN75413	SN75414	4-21
			YES	SN75416	SN75417	SN75418	SN75419	4-25

# PERIPHERAL DRIVER SELECTION GUIDE

## DRIVERS WITHOUT LOGIC GATES

Commercial Temperature Range (0°C to 70°C)

SWITCHING VOLTAGE	MAX RECOMMENDED OUTPUT CURRENT	DRIVERS PER PACKAGE	INTERNAL CLAMP DIODES	DEVICE TYPES			PAGE NUMBER
35 V	1.25 A	4	YES	ULN2064	ULN2066		4-105
			YES	ULN2068			4-109
			YES	SN75064	SN75066		4-5
			YES	SN75068			4-9
			—	SN75074			4-13
			—	ULN2074			4-113
50 V	1.5 A	4	—	UDN2841	UDN2845		4-95
	350 mA	7	YES	ULN2001A	ULN2002A	ULN2003A	4-97
			YES	ULN2004A	ULN2005A		4-97
	1.5 A	4	YES	ULN2065	ULN2067		4-105
			YES	ULN2069			4-109
			YES	SN75065	SN75067		4-5
			YES	SN75069			4-9
			—	SN75075			4-13
			—	ULN2075			4-113
	60 V	350 mA	7	YES	SN75465	SN75466	SN75467
YES				SN75468	SN75469		4-73

VOLTAGE CAPABILITY  
OF PERIPHERAL DRIVERS

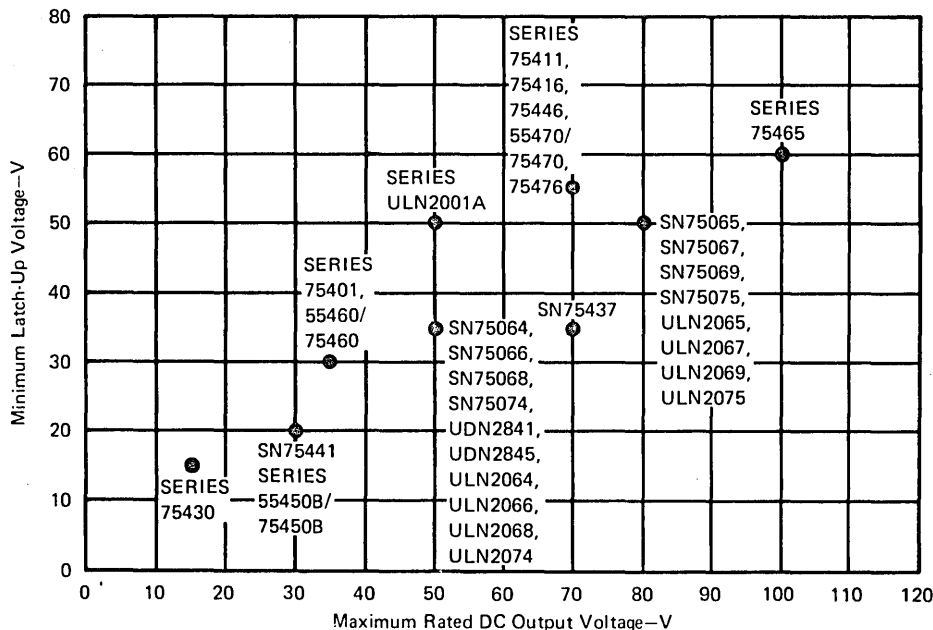

**TEXAS INSTRUMENTS**  
INCORPORATED

POST OFFICE BOX 225012 • DALLAS, TEXAS 75265

# PERIPHERAL DRIVER SELECTION GUIDE

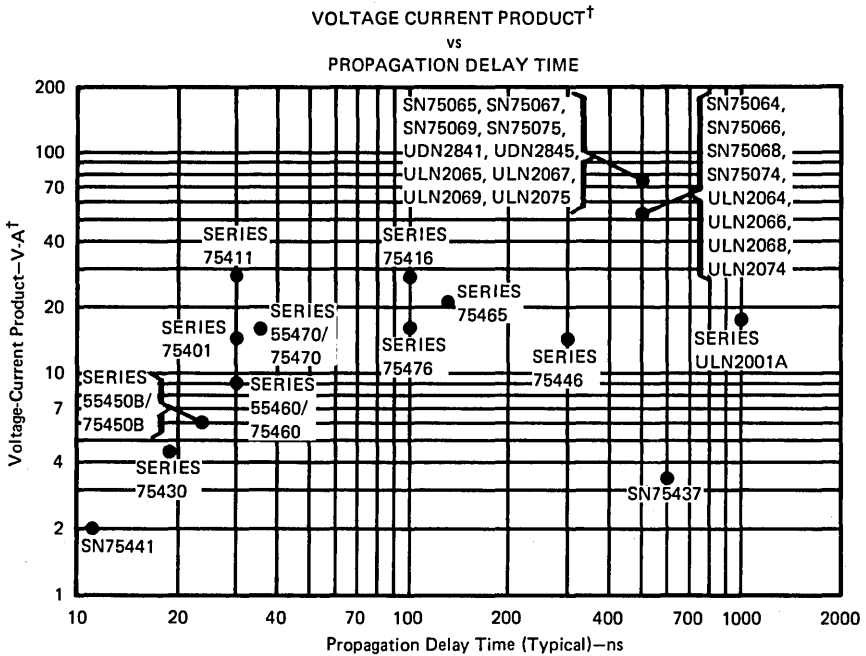
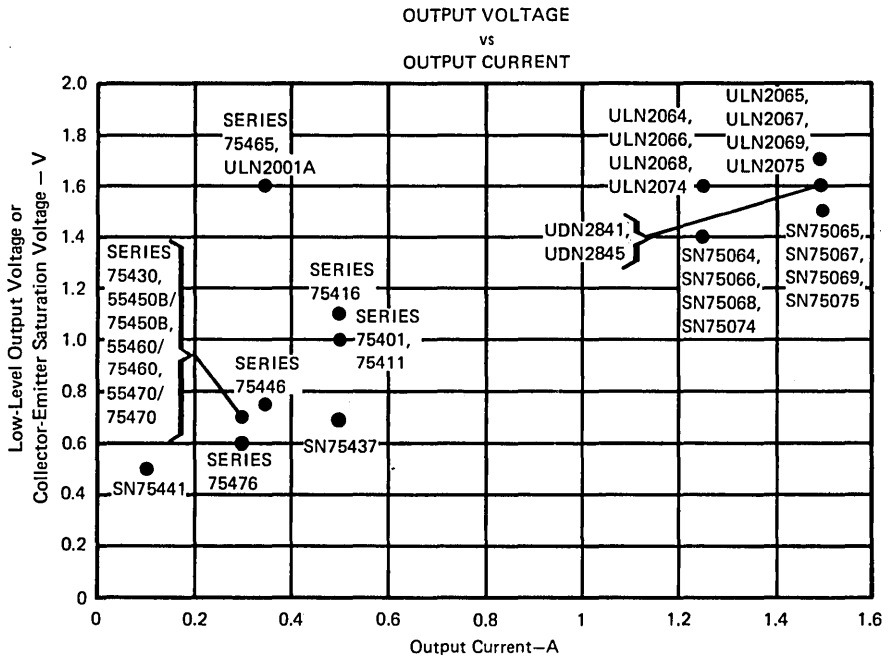

<sup>†</sup>This is the product of the minimum latch-up voltage and the maximum recommended output current.

# INTERFACE CIRCUITS

# TYPES SN75064, SN75065, SN75066, SN75067 QUADRUPLE HIGH-CURRENT DARLINGTON SWITCHES

BULLETIN NO. DL-S 12788, NOVEMBER 1980—REVISED FEBRUARY 1981

- Output Collector Current . . . 1.5 A Max
- 2-W Dissipation Rating
- High Output-Voltage Capability
- Outputs Diode-Clamped for Inductive Loads
- Common-Emitter Circuit for Current Sink
- SN75064 and SN75065 Have TTL-and DTL-Compatible Inputs
- SN75066 and SN75067 Have CMOS-and PMOS-Compatible Inputs
- Functionally Interchangeable with ULN2064 thru ULN2067, Respectively

## description

The SN75064, SN75065, SN75066, and SN75067 are monolithic high-voltage, high-current darlington transistor switches. Each comprises four n-p-n darlington pairs. All units feature high-voltage outputs with common-cathode clamp diodes for switching inductive loads. Outputs and inputs may each be paralleled for higher current capability. Applications include relay drivers, hammer drivers, lamp drivers, display drivers (LED and gas discharge), line drivers, and logic buffers. These common-emitter circuits are designed to operate as current sinks to the load.

The SN75064 and SN75065 are intended for use with TTL, DTL, and 5-volt MOS logic. The SN75066 and SN75067 are intended for use with PMOS and higher voltage CMOS logic.

The SN75064 and SN75067 are characterized for operation from 0°C to 70°C.

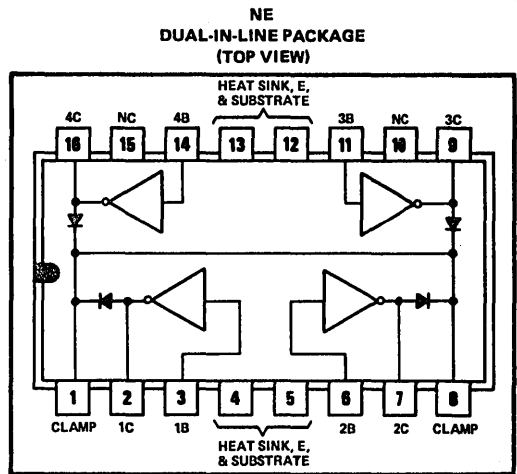

NC — No internal connection

## schematic (each darlington pair)

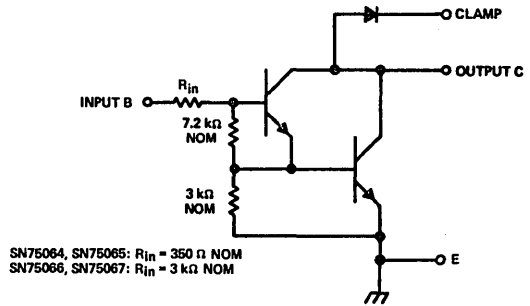

## absolute maximum ratings at 25°C free-air temperature for each switch (unless otherwise noted)

	SN75064	SN75065	SN75066	SN75067	UNIT
Collector-emitter voltage	50	80	50	80	V
Input voltage (see Note 1)	15	15	30	30	V
Peak collector current (see Figures 11, 12, and 13)	1.5	1.5	1.5	1.5	A
Input current	25	25	25	25	mA
Total power dissipation at (or below) 25°C free-air temperature (see Note 2)	2075	2075	2075	2075	mW
Operating free-air temperature range	0 to 70	0 to 70	0 to 70	0 to 70	°C
Storage temperature range	-55 to 150	-55 to 150	-55 to 150	-55 to 150	°C
Lead temperature 1/16 inch (1.6 mm) from the case for 10 seconds	260	260	260	260	°C

NOTES: 1. All voltage values (unless otherwise noted) are with respect to the emitter/substrate terminal E.

2. For operation above 25°C free-air temperature, derate total power to 1328 mW at 70°C at the rate of 16.6 mW/°C.

Copyright © 1981 by Texas Instruments Incorporated

TEXAS INSTRUMENTS  
INCORPORATED

POST OFFICE BOX 225012 • DALLAS, TEXAS 75265

# TYPES SN75064, SN75065, SN75066, SN75067 QUADRUPLE HIGH-CURRENT DARLINGTON SWITCHES

electrical characteristics at 25°C free-air temperature (unless otherwise noted)

PARAMETER	TEST FIGURE	TEST CONDITIONS	SN75064		SN75065		SN75066		SN75067		UNIT
			MIN	MAX	MIN	MAX	MIN	MAX	MIN	MAX	
$V_{CE(sus)}$ Collector sustaining voltage	1	$V_I = 0.4\text{ V}, I_C = 100\text{ mA}$	35		50		35		50		V
$I_{CEX}$ Collector output cutoff current	2	$V_{CE} = 50\text{ V}$	100				100				$\mu\text{A}$
		$V_{CE} = 50\text{ V}, T_A = 70^\circ\text{C}$	500				500				
		$V_{CE} = 80\text{ V}$			100				100		
		$V_{CE} = 80\text{ V}, T_A = 70^\circ\text{C}$			500				500		
$I_{I(on)}$ On-state input current	3	$V_I = 2.4\text{ V}$	2	4.3	2	4.3					mA
		$V_I = 3.75\text{ V}$	4.5	9.6	4.5	9.6					
		$V_I = 5\text{ V}$					0.9	1.8	0.9	1.8	
		$V_I = 12\text{ V}$					2.75	5.2	2.75	5.2	
$V_{I(on)}$ On-state input voltage	4	$V_{CE} = 2\text{ V}, I_C = 1\text{ A}$	2		2		6.5		6.5		V
		$V_{CE} = 2\text{ V}, I_C = 1.5\text{ A},$ See Note 3	2.5		2.5		10		10		
$V_{CE(sat)}$ Collector-emitter saturation voltage	5	$I_I = 625\text{ }\mu\text{A}, I_C = 500\text{ mA}$	1.13		1.13		1.13		1.13		V
		$I_I = 935\text{ }\mu\text{A}, I_C = 750\text{ mA}$	1.25		1.25		1.25		1.25		
		$I_I = 1.25\text{ mA}, I_C = 1\text{ A}$	1.4		1.4		1.4		1.4		
		$I_I = 2\text{ mA}, I_C = 1.25\text{ A},$ See Note 3	1.6				1.6				
$I_R$ Clamp-diode reverse current	6	$V_R = 50\text{ V}$	50				50				$\mu\text{A}$
		$V_R = 50\text{ V}, T_A = 70^\circ\text{C}$	100				100				
		$V_R = 80\text{ V}$			50				50		
		$V_R = 80\text{ V}, T_A = 70^\circ\text{C}$			100				100		
$V_F$ Clamp-diode forward voltage	7	$I_F = 1\text{ A}$	1.75		1.75		1.75		1.75		V
		$I_F = 1.5\text{ A},$ See Note 3	2		2		2		2		

NOTE 3: These parameters must be measured on one output at a time using pulse techniques.  $t_w = 10\text{ ms}$ , duty cycle  $\leq 10\%$ .

switching characteristics at 25°C free-air temperature,  $V_{CC} = 5\text{ V}$

PARAMETER	TEST CONDITIONS	MIN	TYP	MAX	UNIT
$t_{PLH}$ Propagation delay time, low-to-high-level output	See Figure 8			1	$\mu\text{s}$
$t_{PHL}$ Propagation delay time, high-to-low-level output				1.5	$\mu\text{s}$

## PARAMETER MEASUREMENT INFORMATION

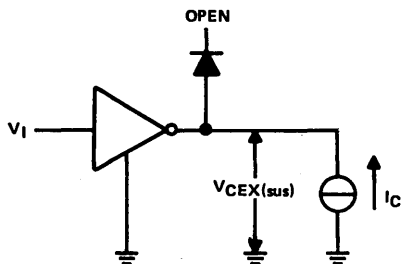

FIGURE 1— $V_{CE(sus)}$

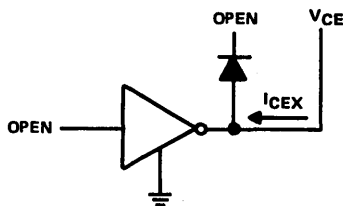

FIGURE 2— $I_{CEX}$

# TYPES SN75064, SN75065, SN75066, SN75067 QUADRUPLE HIGH-CURRENT DARLINGTON SWITCHES

## PARAMETER MEASUREMENT INFORMATION

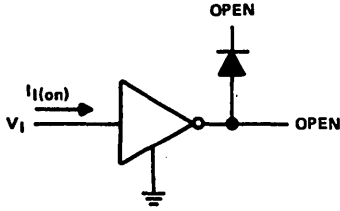

FIGURE 3— $I_{I(on)}$

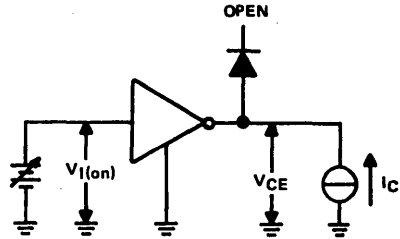

FIGURE 4— $V_{I(on)}$

4

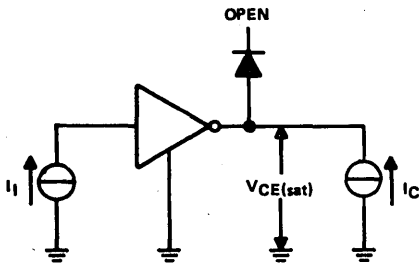

FIGURE 5— $V_{CE(sat)}$

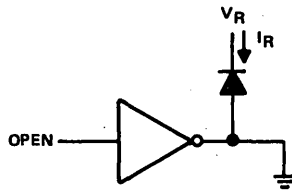

FIGURE 6— $I_R$

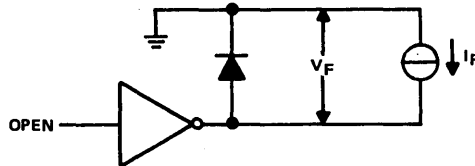
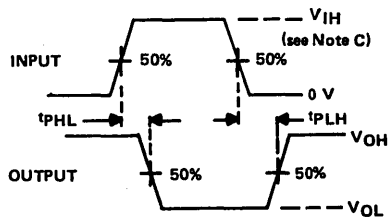
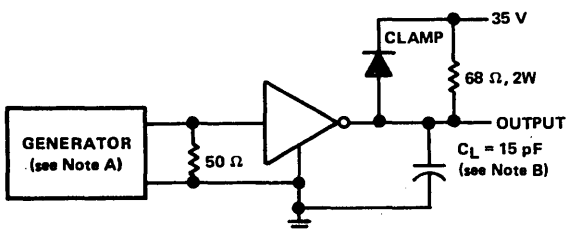

FIGURE 7— $V_F$



NOTES: A. The input pulse is supplied by a generator having the following characteristics: PRR = 50 kHz, duty cycle = 10%,  $Z_o = 50 \Omega$ .  
 B.  $C_L$  includes all probe and stray capacitance.  
 C.  $V_{IH} = 2.5$  V for SN75064 and SN75065.  $V_{IH} = 10$  V for SN75066 and SN75067.

FIGURE 8—SWITCHING TIMES

**TEXAS INSTRUMENTS**  
INCORPORATED

POST OFFICE BOX 225012 • DALLAS, TEXAS 75265

# TYPES SN75064, SN75065, SN75066, SN75067 QUADRUPLE HIGH-CURRENT DARLINGTON SWITCHES

## ELECTRICAL CHARACTERISTICS

SN75064, SN75065

INPUT CURRENT  
vs  
INPUT VOLTAGE

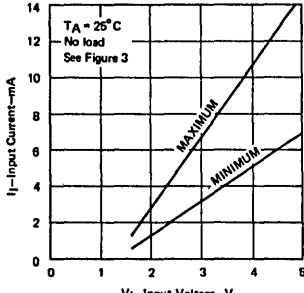

FIGURE 9

SN75066, SN75067

INPUT CURRENT  
vs  
INPUT VOLTAGE

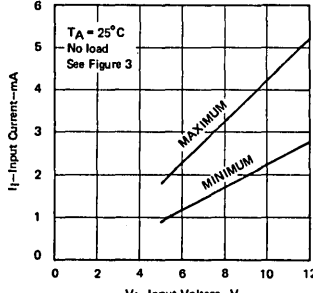

FIGURE 10

COLLECTOR CURRENT  
vs  
BASE CURRENT

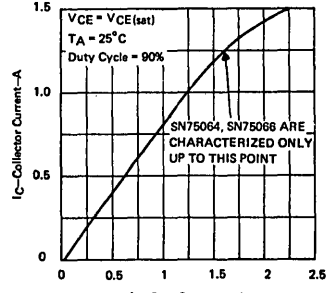

FIGURE 11

## THERMAL INFORMATION

MAXIMUM COLLECTOR CURRENT  
vs  
DUTY CYCLE

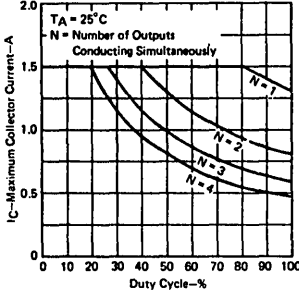

FIGURE 12

MAXIMUM COLLECTOR CURRENT  
vs  
DUTY CYCLE

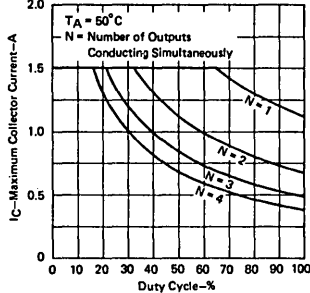

FIGURE 13

MAXIMUM COLLECTOR CURRENT  
vs  
DUTY CYCLE

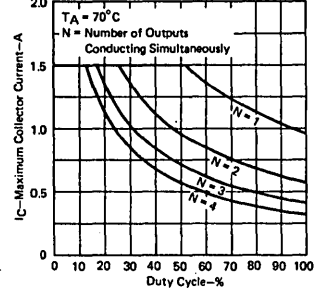

FIGURE 14

## TYPICAL APPLICATION DATA

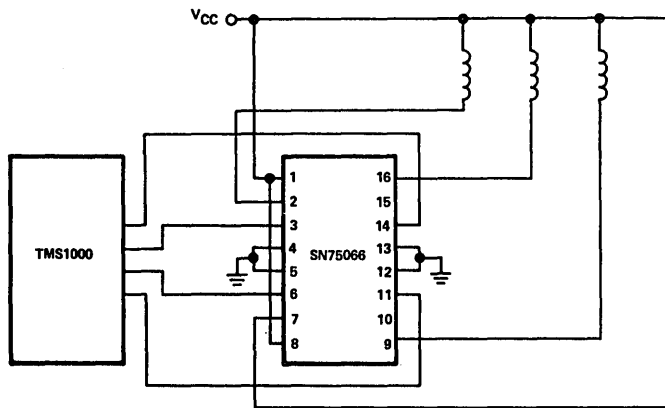

FIGURE 15—RELAY DRIVER INTERFACE



# INTERFACE CIRCUITS

# TYPES SN75068, SN75069 QUADRUPLE HIGH-CURRENT DARLINGTON SWITCHES

BULLETIN NO DL-S 12789, DECEMBER 1979 - REVISED FEBRUARY 1981

- Output Collector Current . . . 1.5 A Max
- 2-W Dissipation Rating
- High Output-Voltage Capability
- Preamp for High Current Gain
- Outputs Diode-Clamped for Inductive Loads
- Common-Emitter Circuit for Current Sink
- Inputs Compatible with TTL and 5-Volt CMOS
- Functionally Interchangeable with ULN2068 and ULN2069

### description

The SN75068 and SN75069 are monolithic integrated circuits each consisting of four high-voltage, high-current n-p-n cascaded transistor switches. Each switch includes a first stage compatible with both TTL and 5-volt CMOS signal levels. The second and third stages form uncommitted-collector outputs with common-cathode clamp diodes for switching inductive loads.

The SN75068 and SN75069 can sink up to 1.5 amperes per switch. Applications include logic buffers, MOS drivers, memory drivers, line drivers, relay drivers, hammer drivers, lamp drivers, and display drivers (LED and gas discharge).

The SN75068 and SN75069 are characterized for operation from 0°C to 70°C.

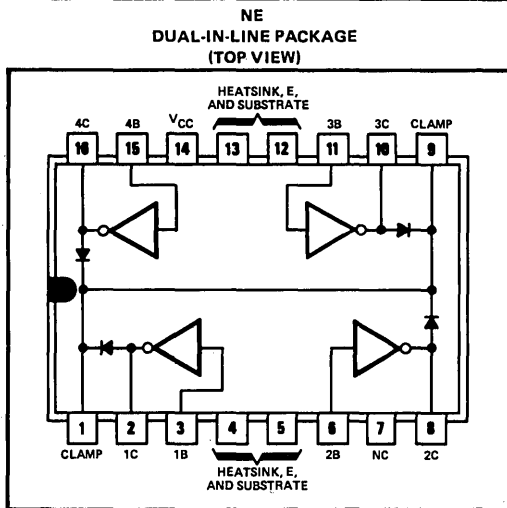

NC—No internal connection

### schematic (each switch)

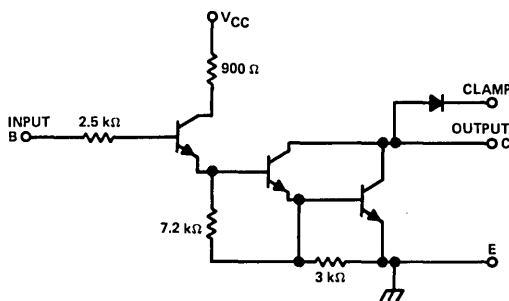

Resistor values shown are nominal.

### absolute maximum ratings at 25°C free-air temperature for each switch (unless otherwise noted)

	SN75068	SN75069	UNIT
Collector-emitter voltage	50	80	V
Supply voltage, $V_{CC}$ (see Note 1)	10	10	V
Input voltage	15	15	V
Peak collector current (see Figures 10, 11, and 12)	1.5	1.5	A
Total power dissipation at (or below) 25°C free-air temperature (see Note 2)	2075	2075	mW
Operating free-air temperature range	0 to 70	0 to 70	°C
Storage temperature range	-55 to 150	-55 to 150	°C
Lead temperature 1/16 inch (1,6 mm) from the case for 10 seconds	260	260	°C

- NOTES: 1. All voltage values (unless otherwise noted) are with respect to the emitter/substrate terminal E.  
2. For operation above 25°C free-air temperature, derate total power to 1328 mW at 70°C at the rate of 16.6 mW/°C.

Copyright © 1981 by Texas Instruments Incorporated

TEXAS INSTRUMENTS  
INCORPORATED

POST OFFICE BOX 225012 • DALLAS, TEXAS 75265

# TYPES SN75068, SN75069

## QUADRUPLE HIGH-CURRENT DARLINGTON SWITCHES

electrical characteristics at 25°C free-air temperature,  $V_{CC} = 5\text{ V}$  (unless otherwise noted)

PARAMETER	TEST FIGURE	TEST CONDITIONS	SN75068		SN75069		UNIT	
			MIN	MAX	MIN	MAX		
$V_{CE(sus)}$ Collector sustaining voltage	1	$V_I = 0.4\text{ V}$ , $I_C = 100\text{ mA}$	35		50		V	
$I_{CEX}$ Collector output cutoff current	2	$V_{CE} = 50\text{ V}$		100			$\mu\text{A}$	
		$V_{CE} = 50\text{ V}$ , $T_A = 70^\circ\text{C}$		500				
		$V_{CE} = 80\text{ V}$				100		
		$V_{CE} = 80\text{ V}$ , $T_A = 70^\circ\text{C}$				500		
$I_{I(on)}$ On-state input current	3	$V_I = 2.4\text{ V}$		250		250	$\mu\text{A}$	
		$V_I = 3.75\text{ V}$		1000		1000		
$V_{I(on)}$ On-state input voltage	4	$V_{CE} = 2\text{ V}$ , $I_C = 1.5\text{ A}$ , See Note 3		2.4		2.4	V	
$V_{CE(sat)}$ Collector-emitter saturation voltage	5	$V_I = 2.4\text{ V}$ , $I_C = 500\text{ mA}$		1.13		1.13	V	
		$V_I = 2.4\text{ V}$ , $I_C = 750\text{ mA}$		1.25		1.25		
		$V_I = 2.4\text{ V}$ , $I_C = 1\text{ A}$		1.4		1.4		
		$V_I = 2.4\text{ V}$ , $I_C = 1.25\text{ A}$ , See Note 3		1.6				
		$V_I = 2.4\text{ V}$ , $I_C = 1.5\text{ A}$ , See Note 3				1.7		
$I_R$ Clamp-diode reverse current	6	$V_R = 50\text{ V}$		50			$\mu\text{A}$	
		$V_R = 50\text{ V}$ , $T_A = 70^\circ\text{C}$		100				
		$V_R = 80\text{ V}$				50		
		$V_R = 80\text{ V}$ , $T_A = 70^\circ\text{C}$				100		
$V_F$ Clamp-diode forward voltage	7	$I_F = 1\text{ A}$		1.75		1.75	V	
		$I_F = 1.5\text{ A}$ , See Note 3		2		2		
$I_{CC}$ Supply current (only one switch conducting)	8	$V_I = 2.4\text{ V}$ , $I_C = 500\text{ mA}$		6		6	$\text{mA}$	

NOTE 3: These parameters must be measured on one output at a time using pulse techniques.  $t_w = 10\text{ ms}$ , duty cycle  $\leq 10\%$ .

switching characteristics at 25°C free-air temperature,  $V_{CC} = 5\text{ V}$

PARAMETER	TEST CONDITIONS	MIN	TYP	MAX	UNIT
$t_{PLH}$ Propagation delay time, low-to-high-level output	See Figure 9			1	$\mu\text{s}$
$t_{PHL}$ Propagation delay time, high-to-low-level output				1.5	$\mu\text{s}$

### PARAMETER MEASUREMENT INFORMATION

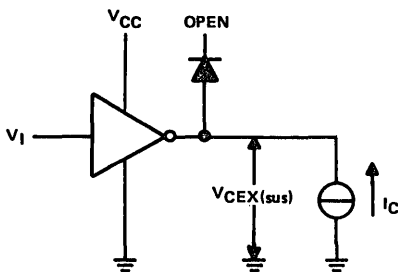

FIGURE 1— $V_{CE(sus)}$

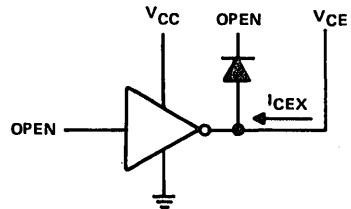

FIGURE 2— $I_{CEX}$

# TYPES SN75068, SN75069 QUADRUPLE HIGH-CURRENT DARLINGTON SWITCHES

## PARAMETER MEASUREMENT INFORMATION

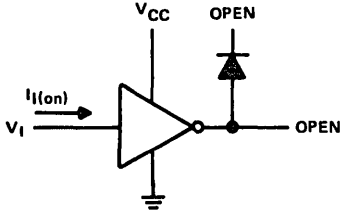

FIGURE 3— $I_{I(on)}$

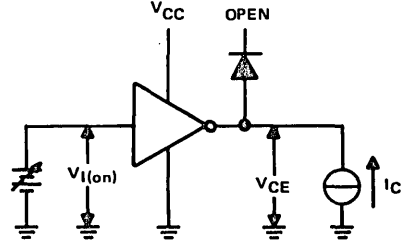

FIGURE 4— $V_{I(on)}$

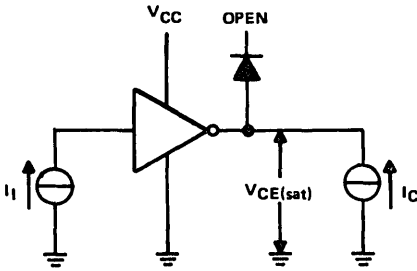

FIGURE 5— $V_{CE(sat)}$

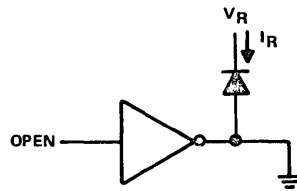

FIGURE 6— $I_R$

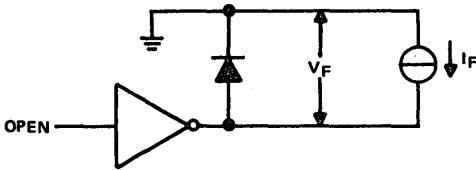

FIGURE 7— $V_F$

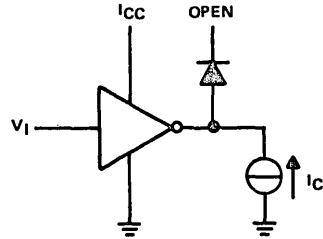
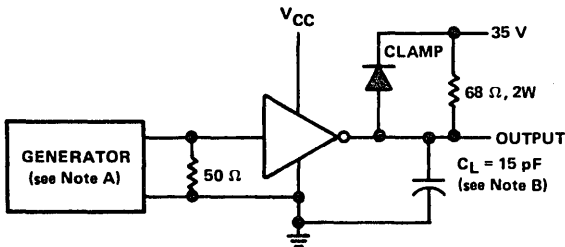
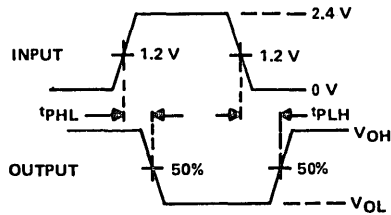

FIGURE 8— $I_{CC}$



TEST CIRCUIT



VOLTAGE WAVEFORMS

NOTES: A. The input pulse is supplied by a generator having the following characteristics: PRR = 50 kHz, duty cycle = 10%,  $Z_0 = 50 \Omega$ .  
B.  $C_L$  includes all probe and stray capacitance.

FIGURE 9—SWITCHING TIMES

# TYFES SN75068, SN75069 QUADRUPLE HIGH-CURRENT DARLINGTON SWITCHES

## THERMAL INFORMATION

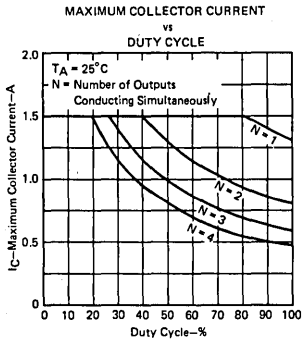

FIGURE 10

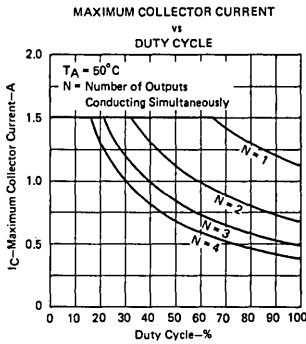

FIGURE 11

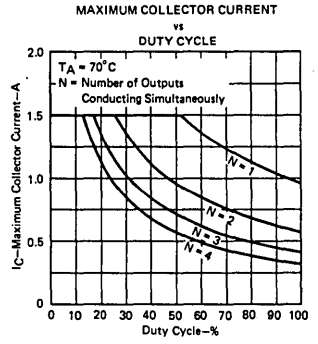

FIGURE 12

## TYPICAL APPLICATION DATA

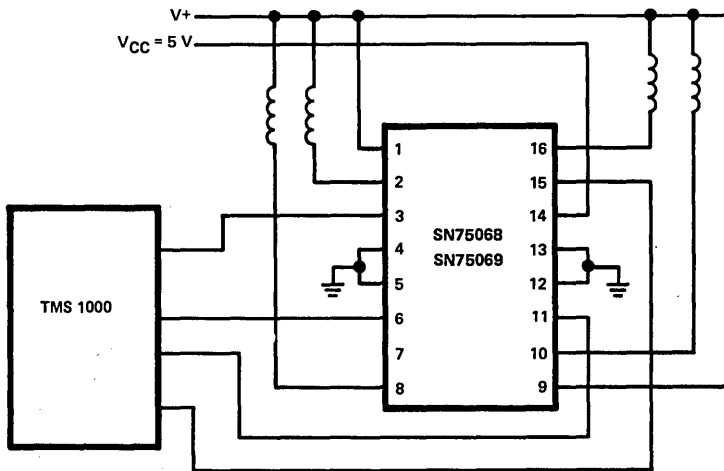

FIGURE 13—RELAY DRIVER INTERFACE

# INTERFACE CIRCUITS

# TYPES SN75074, SN75075 QUADRUPLE HIGH-CURRENT DARLINGTON SWITCHES

BULLETIN NO. DL-S 12792, NOVEMBER 1980 — REVISED FEBRUARY 1981

- Output Collector Current . . . 1.5 A Max
- 2-W Dissipation Rating
- High Output-Voltage Capability
- Output Sink- or Source-Current Capabilities
- Input Compatible With TTL or 5-V CMOS
- Functionally Interchangeable with ULN2074 and ULN2075

## description

The SN75074 and SN75075 are monolithic, quadruple, high-voltage, high-current n-p-n darlington-transistor amplifier devices. They feature high-voltage outputs with collector-current ratings of 1.5 amperes for each darlington pair.

The SN75074 and SN75075 are unique general purpose devices, each featuring uncommitted collectors and emitters to allow for either sinking or sourcing the output current. These devices offer the system designer the flexibility of tailoring the circuit to the application. Typical applications include logic buffers, relay drivers, lamp drivers, and hammer drivers.

The SN75074 and SN75075 are characterized for operation from 0°C to 70°C.

NE  
DUAL-IN-LINE PACKAGE  
(TOP VIEW)

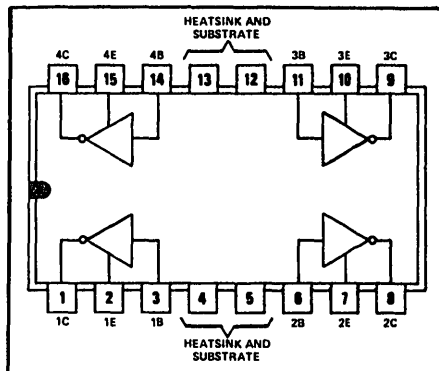

schematic (each switch)

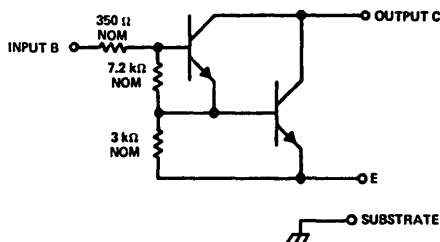

absolute maximum ratings at 25°C free-air temperature for each switch (unless otherwise noted)

	ULN2074	ULN2075	UNIT
Collector-emitter voltage	50	80	V
Input voltage with respect to substrate	30	60	V
Peak collector current (see Figures 9, 10, and 11)	1.5	1.5	A
Input current	25	25	mA
Total power dissipation at (or below) 25°C free-air temperature (see Note 1)	2075	2075	mW
Operating free-air temperature range	0 to 70	0 to 70	°C
Storage temperature range	-55 to 150	-55 to 150	°C
Lead temperature 1/16 inch (1,6 mm) from the case for 10 seconds	260	260	°C

NOTE 1: For operation above 25°C free-air temperature, derate total power to 1328 mW at 70°C at the rate of 16.6 mW/°C.

Copyright © 1981 by Texas Instruments Incorporated

TEXAS INSTRUMENTS  
INCORPORATED

POST OFFICE BOX 225012 • DALLAS, TEXAS 75265

# TYPES SN75074, SN75075

## QUADRUPLE HIGH-CURRENT DARLINGTON SWITCHES

electrical characteristics at 25°C free-air temperature (unless otherwise noted)

PARAMETER	TEST FIGURE	TEST CONDITIONS	SN75074		SN75075		UNIT
			MIN	MAX	MIN	MAX	
$V_{CEX(sus)}$ Collector sustaining voltage	1	$V_I = 0.4\text{ V}$ , $I_C = 100\text{ mA}$	35		50		V
$I_{CEX}$ Collector output cutoff current	2	$V_{CE} = 50\text{ V}$	100				$\mu\text{A}$
		$V_{CE} = 50\text{ V}$ , $T_A = 70^\circ\text{C}$	500				
		$V_{CE} = 80\text{ V}$			100		
		$V_{CE} = 80\text{ V}$ , $T_A = 70^\circ\text{C}$			500		
$I_{I(on)}$ On-state input current	3	$V_I = 2.4\text{ V}$	2	4.3	2	4.3	mA
		$V_I = 3.75\text{ V}$	4.5	9.6	4.5	9.6	
$V_{I(on)}$ On-state input voltage	4	$V_{CE} = 2\text{ V}$ , $I_C = 1\text{ A}$	2		2		V
		$V_{CE} = 2\text{ V}$ , $I_C = 1.5\text{ A}$ , See Note 2	2.5		2.5		
$V_{CE(sat)}$ Collector-emitter saturation voltage	5	$I_I = 625\ \mu\text{A}$ , $I_C = 500\text{ mA}$	1.13		1.13		V
		$I_I = 935\ \mu\text{A}$ , $I_C = 750\text{ mA}$	1.25		1.25		
		$I_I = 1.25\text{ mA}$ , $I_C = 1\text{ A}$	1.4		1.4		
		$I_I = 2\text{ mA}$ , $I_C = 1.25\text{ A}$ , See Note 2	1.6				
		$I_I = 2.25\text{ mA}$ , $I_C = 1.5\text{ A}$ , See Note 2				1.7	

NOTE 2: These parameters must be measured on one output at a time using pulse techniques,  $t_w = 10\text{ ms}$ , duty cycle  $< 10\%$ .

### switching characteristics at 25°C free-air temperature

PARAMETER	TEST CONDITIONS	MIN	TYP	MAX	UNIT
$t_{PLH}$ Propagation delay time, low-to-high-level output	See Figure 6			1	$\mu\text{s}$
$t_{PHL}$ Propagation delay time, high-to-low-level output				1.5	$\mu\text{s}$

### PARAMETER MEASUREMENT INFORMATION

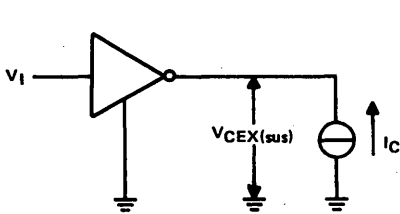

FIGURE 1— $V_{CEX(sus)}$

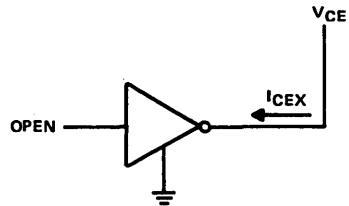

FIGURE 2— $I_{CEX}$

# TYPES SN75074, SN75075 QUADRUPLE HIGH-CURRENT DARLINGTON SWITCHES

## PARAMETER MEASUREMENT INFORMATION

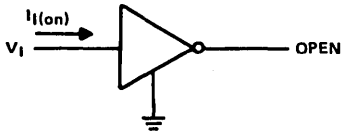

FIGURE 3— $I_{I(on)}$

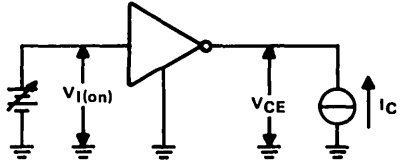

FIGURE 4— $V_{I(on)}$

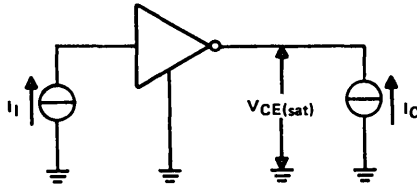
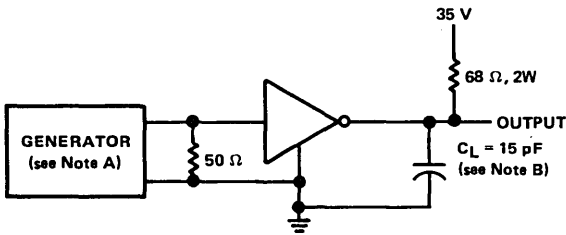
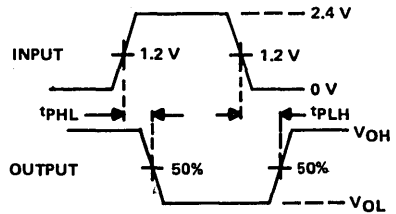

FIGURE 5— $V_{CE(sat)}$



TEST CIRCUITS



VOLTAGE WAVEFORMS

NOTES: A. The input pulse is supplied by a generator having the following characteristics: PRR = 50 kHz, duty cycle = 10%,  $Z_0 = 50 \Omega$ .  
B.  $C_L$  includes all probe and stray capacitance.

FIGURE 6—SWITCHING CHARACTERISTICS

# TYPES SN75074, SN75075 QUADRUPLE HIGH-CURRENT DARLINGTON SWITCHES

## ELECTRICAL CHARACTERISTICS

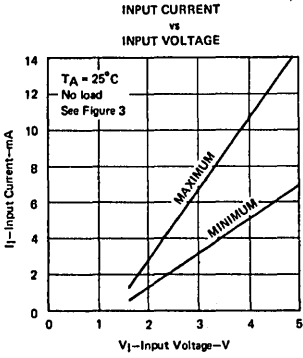

FIGURE 7

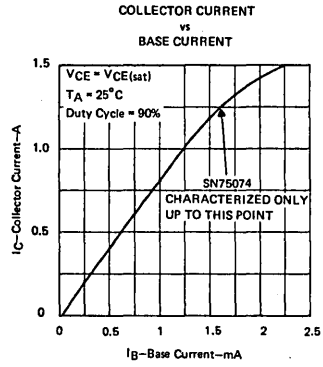

FIGURE 8

## THERMAL INFORMATION

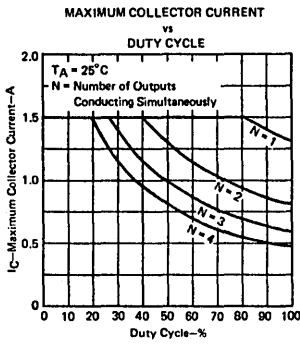

FIGURE 9

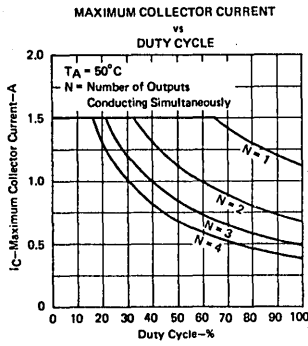

FIGURE 10

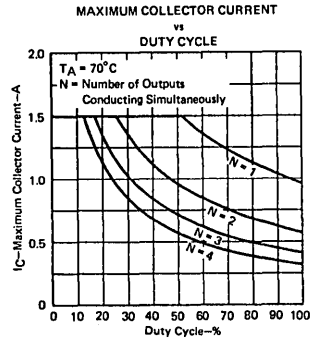

FIGURE 11

## TYPICAL APPLICATION DATA

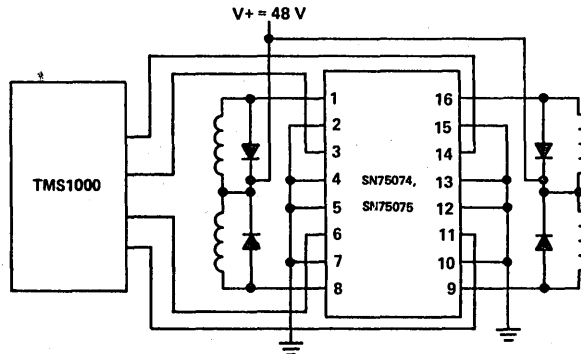

FIGURE 12—RELAY DRIVER INTERFACE WITH EXTERNAL CLAMP DIODES



## PERIPHERAL DRIVERS FOR HIGH-VOLTAGE, VERY HIGH-CURRENT DRIVER APPLICATIONS

### performance

- 2-W Dissipation Rating
- Characterized for Use to 500 mA
- High-Voltage Outputs
- No Output Latch-Up at 30 V (After Conducting 300 mA)
- Medium-Speed Switching

### ease-of-design

- Circuit Flexibility for Varied Applications and Choice of Logic Function
- TTL or DTL Compatible Diode-Clamped Inputs
- Standard Supply Voltage

### description

Series 75401 dual peripheral drivers are a family of versatile devices designed for use in systems that employ DTL or TTL logic. SN75401, SN75402, SN75403, and SN75404 provide AND, NAND, OR, and NOR drivers, respectively, (assuming positive logic) and are identical to SN75461 through SN75464 except that the package allows the output current capability to be increased to 500 mA. Diode-clamped inputs simplify circuit design. Typical applications include high-speed logic buffers, power drivers, relay drivers, lamp drivers, MOS drivers, line drivers, and memory drivers. Series 75401 drivers are characterized for operation from 0°C to 70°C.

### schematics of inputs and output

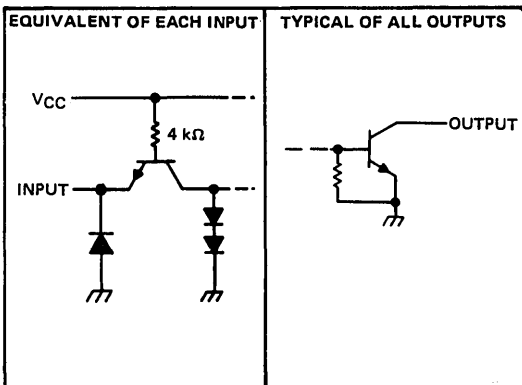

SN75401

NE DUAL-IN-LINE PACKAGE (TOP VIEW)

FUNCTION TABLE  
(EACH AND DRIVER)

INPUTS		OUTPUT
A	B	Y
L	L	L
L	H	L
H	L	L
H	H	H

H = high-level  
L = low-level

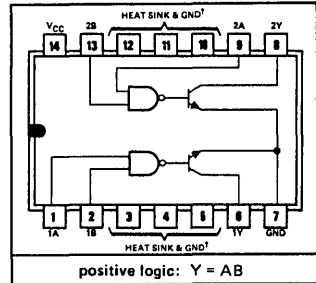

SN75402

NE DUAL-IN-LINE PACKAGE (TOP VIEW)

FUNCTION TABLE  
(EACH NAND DRIVER)

INPUTS		OUTPUT
A	B	Y
L	L	H
L	H	H
H	L	H
H	H	L

H = high-level  
L = low-level

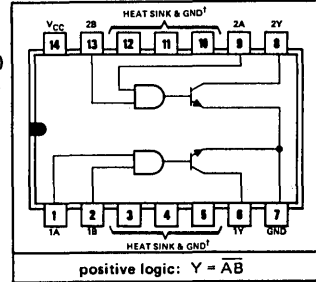

SN75403

NE DUAL-IN-LINE PACKAGE (TOP VIEW)

FUNCTION TABLE  
(EACH OR DRIVER)

INPUTS		OUTPUT
A	B	Y
L	L	L
L	H	H
H	L	H
H	H	H

H = high-level  
L = low-level

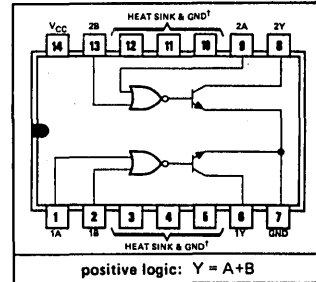

SN75404

NE DUAL-IN-LINE PACKAGE (TOP VIEW)

FUNCTION TABLE  
(EACH NOR DRIVER)

INPUTS		OUTPUT
A	B	Y
L	L	H
L	H	L
H	L	L
H	H	L

H = high-level  
L = low-level

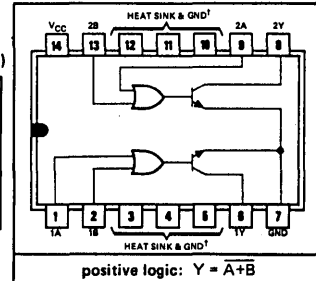

<sup>†</sup>Heat-sink pins are internally connected to pin 7.

# SERIES 75401

## DUAL PERIPHERAL DRIVERS

absolute maximum ratings over operating free-air temperature range (unless otherwise noted)

Supply voltage, $V_{CC}$ (see Note 1)	7 V
Input voltage	5.5 V
Intermitter voltage (see Note 2)	5.5 V
Off-state output voltage	35 V
Continuous output current (see Note 3)	550 mA
Peak output current ( $t_W \leq 10$ ms, duty cycle $\leq 40\%$ , see Note 3)	1000 mA
Continuous total power dissipation at (or below) 30°C free-air temperature (see Note 4)	2 W
Operating free-air temperature range	0°C to 70°C
Storage temperature range	-65°C to 150°C
Lead temperature 1/16 inch from case for 10 seconds	260°C

- NOTES: 1. Voltage values are with respect to network ground terminal unless otherwise specified.  
 2. This is the voltage between two emitters of a multiple-emitter transistor.  
 3. Both halves of these dual circuits may conduct rated current simultaneously; however, power dissipation averaged over a short time interval must fall within the continuous dissipation rating.  
 4. For operation above 30°C free-air temperature, refer to Dissipation Derating Curves in the Thermal Information section, which starts on page 2-1.

recommended operating conditions

	MIN	NOM	MAX	UNIT
Supply voltage, $V_{CC}$	4.75	5	5.25	V
Operating free-air temperature, $T_A$	0		70	°C

electrical characteristics over recommended operating free-air temperature range (unless otherwise noted)

PARAMETER		TEST CONDITIONS	MIN	TYP†	MAX	UNIT		
$V_{IH}$	High level input voltage		2			V		
$V_{IL}$	Low level input voltage				0.8	V		
$V_{IK}$	Input clamp voltage	$V_{CC} = 4.75$ V, $I_I = -12$ mA	-1.2	-1.5		V		
$I_{OH}$	High-level output current	$V_{CC} = 4.75$ V, $V_{IH} = 2$ V, $V_{IL} = 0.8$ V, $V_{OH} = 35$ V			100	μA		
$V_{OL}$	Low-level output voltage	$V_{CC} = 4.75$ V, $I_{OL} = 100$ mA	0.15	0.4		V		
		$V_{IH} = 2$ V, $I_{OL} = 300$ mA	0.36	0.7				
		$V_{IL} = 0.8$ V, $I_{OL} = 500$ mA	0.5	1				
$I_I$	Input current at maximum input voltage	$V_{CC} = 5.25$ V, $V_I = 5.5$ V			1	mA		
$I_{IH}$	High-level input current	$V_{CC} = 5.25$ V, $V_I = 2.4$ V			40	μA		
$I_{IL}$	Low-level input current	$V_{CC} = 5.25$ V, $V_I = 0.4$ V	-1	-1.6		mA		
$I_{CCH}$	Supply current, outputs high	$V_{CC} = 5.25$ V		SN75401	$V_I = 5$ V	8	11	mA
				SN75402	$V_I = 0$	13	17	
				SN75403	$V_I = 5$ V	8	11	
				SN75404	$V_I = 0$	14	19	
$I_{CCL}$	Supply current, outputs low	$V_{CC} = 5.25$ V		SN75401	$V_I = 0$	61	76	mA
				SN75402	$V_I = 5$ V	65	76	
				SN75403	$V_I = 0$	63	76	
				SN75404	$V_I = 5$ V	72	85	

† All typical values are at  $V_{CC} = 5$  V,  $T_A = 25^\circ$  C.

switching characteristics,  $V_{CC} = 5\text{ V}$ ,  $T_A = 25^\circ\text{C}$

PARAMETER	TEST CONDITIONS	SN75401			SN75402			SN75403			SN75404			UNIT
		MIN	TYP	MAX	MIN	TYP	MAX	MIN	TYP	MAX	MIN	TYP	MAX	
$t_{PLH}$ Propagation delay time, low-to-high-level output	$I_O \approx 200\text{ mA}$ ,	30	55		45	65		30	55		40	65	ns	
$t_{PHL}$ Propagation delay time, high-to-low-level output	$C_L = 15\text{ pF}$ ,	25	40		30	50		25	40		30	50	ns	
$t_{TLH}$ Transition time, low-to-high-level output	$R_L = 50\ \Omega$ ,	8	20		13	25		8	25		8	20	ns	
$t_{THL}$ Transition time, high-to-low-level output	See Figure 1	10	20		10	20		10	25		10	20	ns	
$V_{OH}$ High-level output voltage after switching	$V_S = 30\text{ V}$ , $I_O \approx 300\text{ mA}$ , See Figure 2	$V_S - 10$			$V_S - 10$			$V_S - 10$			$V_S - 10$			mV

PARAMETER MEASUREMENT INFORMATION

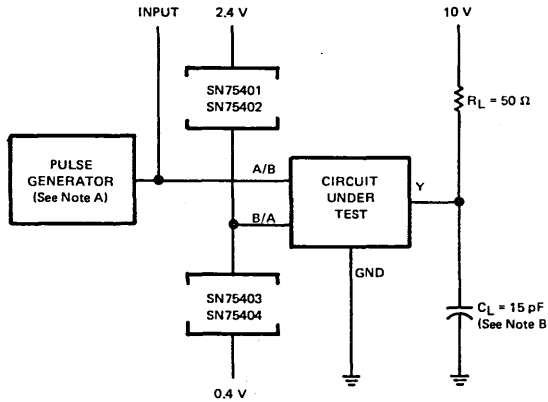

TEST CIRCUIT

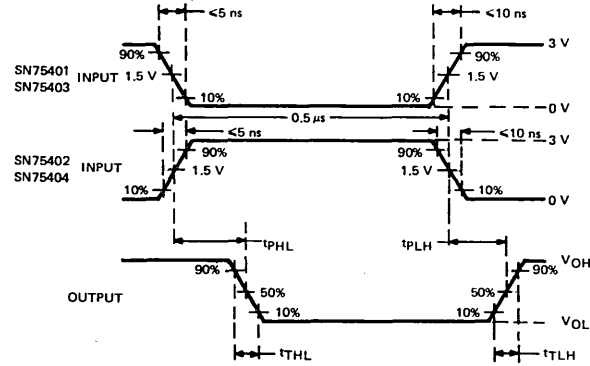

VOLTAGE WAVEFORMS

NOTES: A. The pulse generator has the following characteristics: PRR = 1 MHz,  $Z_{out} \approx 50\ \Omega$ .  
B.  $C_L$  includes probe and jig capacitance.

FIGURE 1—SWITCHING TIMES



# SERIES 75401 DUAL PERIPHERAL DRIVERS

## PARAMETER MEASUREMENT INFORMATION

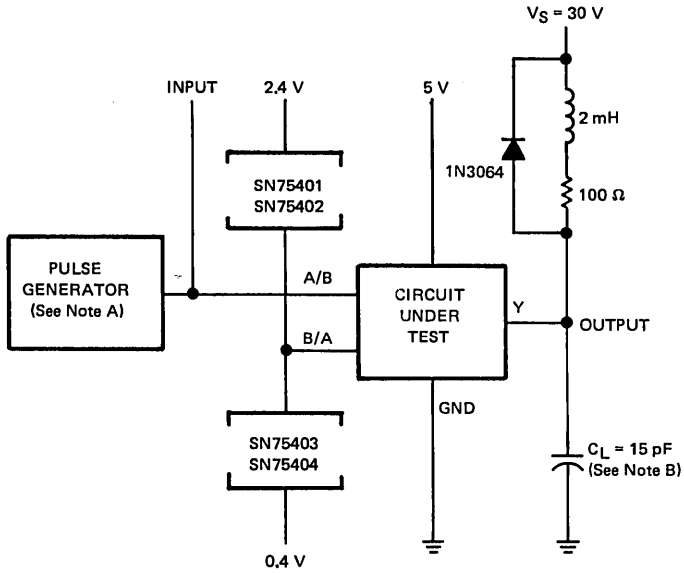

TEST CIRCUIT

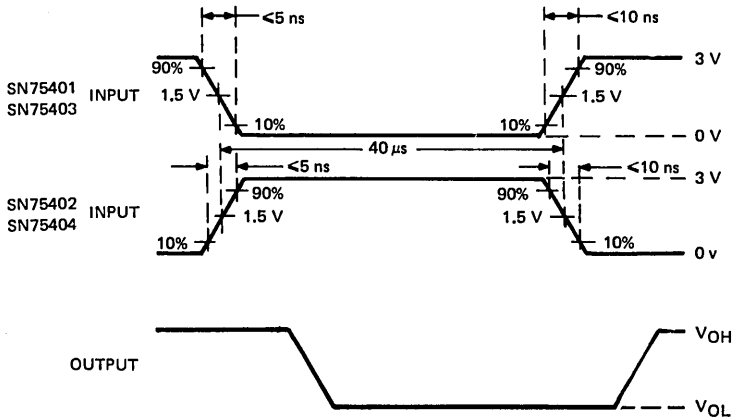

VOLTAGE WAVEFORMS

- NOTES: A. The pulse generator has the following characteristics: PRR = 12.5 kHz,  $Z_{out} = 50 \Omega$ .  
B.  $C_L$  includes probe and jig capacitance.

FIGURE 2—LATCH-UP TEST

## PERIPHERAL DRIVERS FOR HIGH-VOLTAGE, VERY HIGH-CURRENT DRIVER APPLICATIONS

### performance

- 2-W Dissipation Rating
- Characterized for Use to 500 mA
- High-Voltage Outputs
- No Output Latch-Up at 55 V (After Conducting 300 mA)
- Medium-Speed Switching

### ease-of-design

- Circuit Flexibility for Varied Applications and Choice of Logic Function
- TTL or DTL Compatible Diode-Clamped Inputs
- Standard Supply Voltage

### description

Series 75411 dual peripheral drivers are a family of versatile devices designed for use in systems that employ DTL or TTL logic. SN75411, SN75412, SN75413, and SN75414 provide AND, NAND, OR, and NOR drivers, respectively, (assuming positive logic) and are identical to SN75471 through SN75474 except that the package allows the output current capability to be increased to 500 mA. Diode-clamped inputs simplify circuit design. Typical applications include high-speed logic buffers, power drivers, relay drivers, lamp drivers, MOS drivers, line drivers, and memory drivers. Series 75411 drivers are characterized for operation from 0°C to 70°C.

### schematics of inputs and output

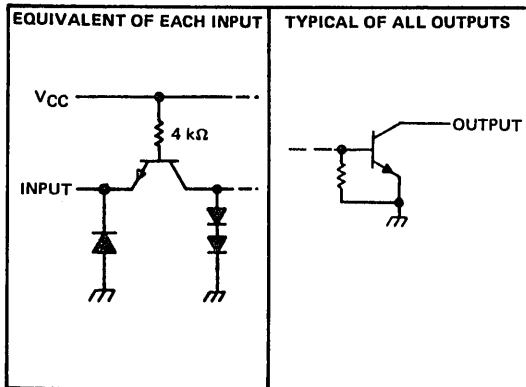

### SN75411

### NE DUAL-IN-LINE PACKAGE (TOP VIEW)

### FUNCTION TABLE (EACH AND DRIVER)

INPUTS		OUTPUT
A	B	Y
L	L	L
L	H	L
H	L	L
H	H	H

H = high-level  
L = low-level

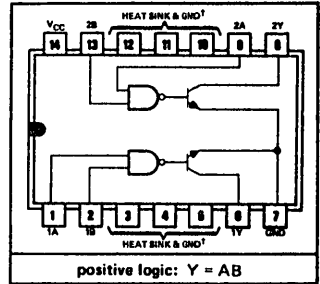

### SN75412

### NE DUAL-IN-LINE PACKAGE (TOP VIEW)

### FUNCTION TABLE (EACH NAND DRIVER)

INPUTS		OUTPUT
A	B	Y
L	L	H
L	H	H
H	L	H
H	H	L

H = high-level  
L = low-level

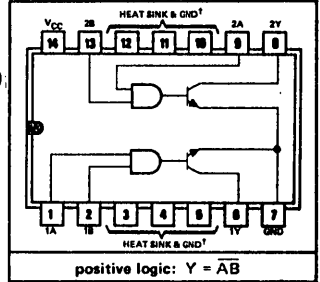

### SN75413

### NE DUAL-IN-LINE PACKAGE (TOP VIEW)

### FUNCTION TABLE (EACH OR DRIVER)

INPUTS		OUTPUT
A	B	Y
L	L	L
L	H	H
H	L	H
H	H	H

H = high-level  
L = low-level

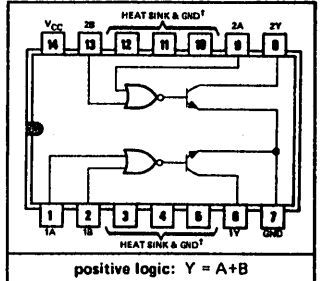

### SN75414

### NE DUAL-IN-LINE PACKAGE (TOP VIEW)

### FUNCTION TABLE (EACH NOR DRIVER)

INPUTS		OUTPUT
A	B	Y
L	L	H
L	H	L
H	L	L
H	H	L

H = high-level  
L = low-level

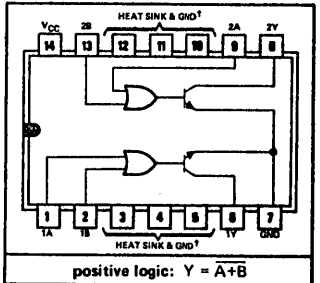

† Heat-sink pins are internally connected to pin 7.

# SERIES 75411

## DUAL PERIPHERAL DRIVERS

absolute maximum ratings over operating free-air temperature range (unless otherwise noted)

Supply voltage, $V_{CC}$ (see Note 1)	7 V
Input voltage	5.5 V
Interemitter voltage (see Note 2)	5.5 V
Off-state output voltage	70 V
Continuous output current (see Note 3)	550 mA
Peak output current ( $t_w \leq 10$ ms, duty cycle $\leq 40\%$ , see Note 3)	1000 mA
Continuous total power dissipation at (or below) 30°C free-air temperature (see Note 4)	2 W
Operating free-air temperature range	0°C to 70°C
Storage temperature range	-65°C to 150°C
Lead temperature 1/16 inch from case for 10 seconds	260°C

- NOTES: 1. Voltage values are with respect to network ground terminal unless otherwise specified.  
 2. This is the voltage between two emitters of a multiple-emitter transistor.  
 3. Both halves of these dual circuits may conduct rated current simultaneously; however, power dissipation averaged over a short time interval must fall within the continuous dissipation rating.  
 4. For operation above 30°C free-air temperature, refer to Dissipation Derating Curves in the Thermal Information section, which starts on page 2-1.

recommended operating conditions

	MIN	NOM	MAX	UNIT
Supply voltage, $V_{CC}$	4.75	5	5.25	V
Operating free-air temperature, $T_A$	0		70	°C

electrical characteristics over recommended operating free-air temperature range (unless otherwise noted)

PARAMETER		TEST CONDITIONS	MIN	TYP <sup>‡</sup>	MAX	UNIT	
$V_{IH}$	High level input voltage		2			V	
$V_{IL}$	Low level input voltage				0.8	V	
$V_{IK}$	Input clamp voltage	$V_{CC} = 4.75$ V, $I_I = -12$ mA	-1.2	-1.5		V	
$I_{OH}$	High-level output current	$V_{CC} = 4.75$ V, $V_{IH} = 2$ V, $V_{IL} = 0.8$ V, $V_{OH} = 70$ V			100	μA	
$V_{OL}$	Low-level output voltage	$V_{CC} = 4.75$ V, $I_{OL} = 100$ mA	0.15	0.4		V	
		$V_{IH} = 2$ V, $I_{OL} = 300$ mA	0.36	0.7			
		$V_{IL} = 0.8$ V, $I_{OL} = 500$ mA	0.5	1			
$I_I$	Input current at maximum input voltage	$V_{CC} = 5.25$ V, $V_I = 5.5$ V			1	mA	
$I_{IH}$	High-level input current	$V_{CC} = 5.25$ V, $V_I = 2.4$ V			40	μA	
$I_{IL}$	Low-level input current	$V_{CC} = 5.25$ V, $V_I = 0.4$ V	-1	-1.6		mA	
$I_{CCH}$	Supply current, outputs high	SN75411	$V_{CC} = 5.25$ V	$V_I = 5$ V	8	11	mA
		SN75412		$V_I = 0$	13	17	
		SN75413		$V_I = 5$ V	8	11	
		SN75414		$V_I = 0$	14	19	
$I_{CCL}$	Supply current, outputs low	SN75411	$V_{CC} = 5.25$ V	$V_I = 0$	61	76	mA
		SN75412		$V_I = 5$ V	65	76	
		SN75413		$V_I = 0$	63	76	
		SN75414		$V_I = 5$ V	72	85	

<sup>‡</sup>All typical values are at  $V_{CC} = 5$  V,  $T_A = 25^\circ\text{C}$ .

switching characteristics,  $V_{CC} = 5\text{ V}$ ,  $T_A = 25^\circ\text{C}$

PARAMETER	TEST CONDITIONS	SN75411			SN75412			SN75413			SN75414			UNIT
		MIN	TYP	MAX	MIN	TYP	MAX	MIN	TYP	MAX	MIN	TYP	MAX	
$t_{pLH}$ Propagation delay time, low-to-high-level output	$I_O \approx 200\text{ mA}$ ,	30	55		45	65		30	55		40	65	ns	
$t_{pHL}$ Propagation delay time, high-to-low-level output	$C_L = 15\text{ pF}$ ,	25	40		30	50		25	40		30	50	ns	
$t_{TLH}$ Transition time, low-to-high-level output	$R_L = 50\ \Omega$ ,	8	20		13	25		8	25		8	20	ns	
$t_{THL}$ Transition time, high-to-low-level output	See Figure 1	10	20		10	20		10	25		10	20	ns	
$V_{OH}$ High-level output voltage after switching	$V_S = 55\text{ V}$ , $I_O \approx 300\text{ mA}$ , See Figure 2	$V_S - 18$			$V_S - 18$			$V_S - 18$			$V_S - 18$			mV

PARAMETER MEASUREMENT INFORMATION

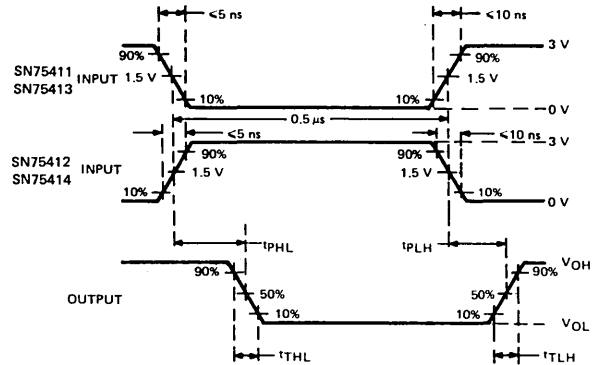
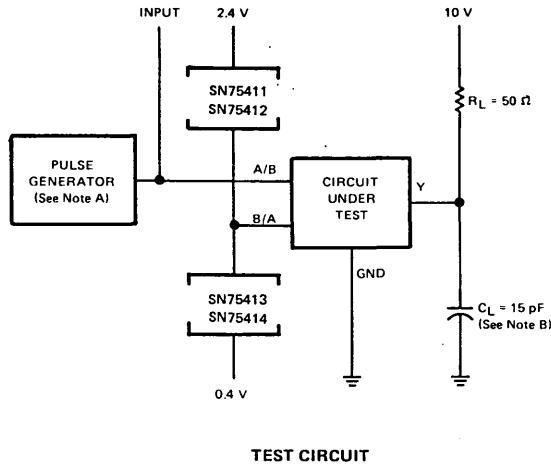

NOTES: A. The pulse generator has the following characteristics: PRR = 1 MHz,  $Z_{out} \approx 50\ \Omega$ .  
B.  $C_L$  includes probe and jig capacitance.

FIGURE 1—SWITCHING TIMES

# SERIES 75411 DUAL PERIPHERAL DRIVERS

## PARAMETER MEASUREMENT INFORMATION

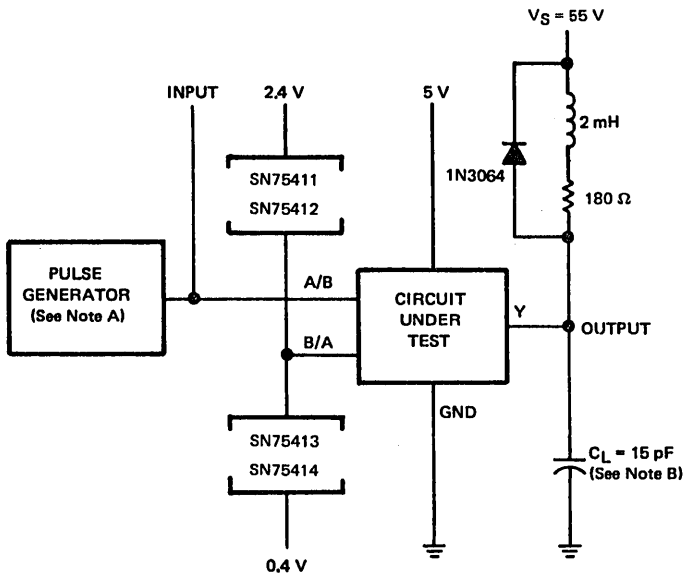

TEST CIRCUIT

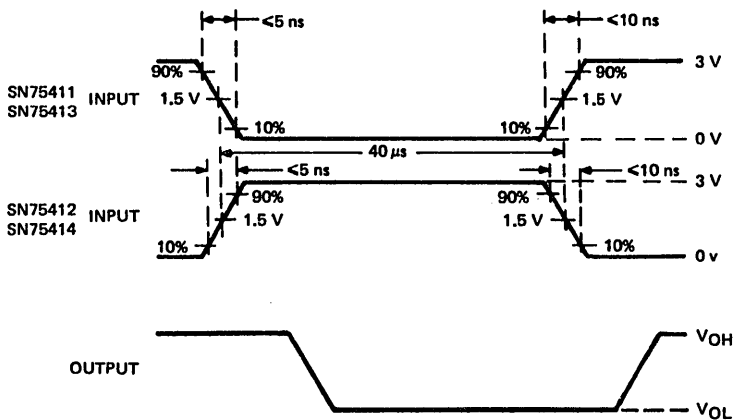

VOLTAGE WAVEFORMS

- NOTES: A. The pulse generator has the following characteristics: PRR = 12.5 kHz,  $Z_{out} = 50 \Omega$ .  
 B.  $C_L$  includes probe and jig capacitance.

FIGURE 2—LATCH-UP TEST



# INTERFACE CIRCUITS

# SERIES 75416 DUAL PERIPHERAL DRIVERS

BULLETIN NO. DL-S 12481, DECEMBER 1976 — REVISED NOVEMBER 1980

- Characterized for Use to 500 mA
- No Output Latch-Up at 55 V (After Conducting 500 mA)
- High-Voltage Outputs (100 V Typical)
- High-Speed Switching
- Output Clamp Diodes for Transient Suppression (500 mA, 70 V)
- TTL- or MOS-Compatible Diode-Clamped Inputs
- P-N-P Inputs Reduce Input Current
- Standard Supply Voltage
- Suitable for Hammer-Driver Applications
- Available in the 14-Pin NE Package
- 2-Watt Power Dissipation Capability

## description

Series 75416 dual peripheral drivers are designed for use in systems that require high output voltage, high current, and fast switching times. The SN75416, SN75417, SN75418, and SN75419 provide AND, NAND, OR, and NOR functions respectively. The devices have diode-clamped inputs as well as high-current, high-voltage inductive clamp diodes on the outputs. Each device has a 2-watt power dissipation capability.

Series 75416 drivers are characterized for operation from 0°C to 70°C.

## schematics of inputs and outputs

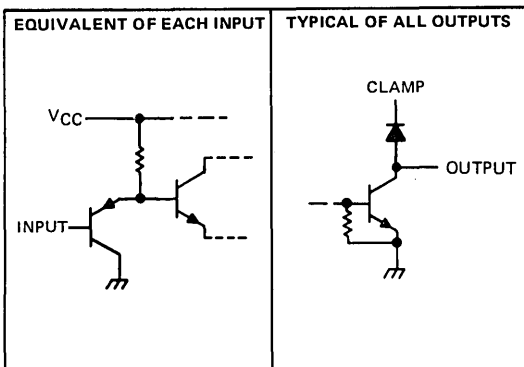

### SN75416

### NE DUAL-IN-LINE PACKAGE (TOP VIEW)

FUNCTION TABLE  
(EACH AND DRIVER)

INPUTS		OUTPUT
A	S	Y
L	L	L
L	H	L
H	L	L
H	H	H

H = high level  
L = low level

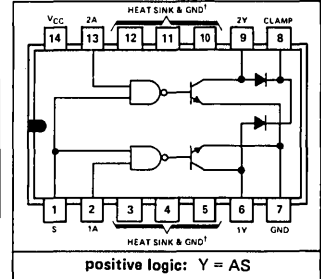

### SN75417

### NE DUAL-IN-LINE PACKAGE (TOP VIEW)

FUNCTION TABLE  
(EACH NAND DRIVER)

INPUTS		OUTPUT
A	S	Y
L	L	H
L	H	H
H	L	H
H	H	L

H = high level  
L = low level

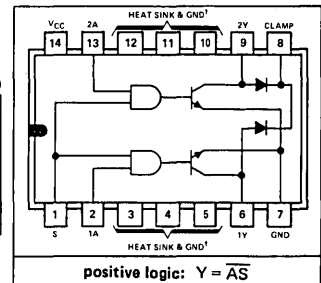

### SN75418

### NE DUAL-IN-LINE PACKAGE (TOP VIEW)

FUNCTION TABLE  
(EACH OR DRIVER)

INPUTS		OUTPUT
A	S	Y
L	L	L
L	H	H
H	L	H
H	H	H

H = high level  
L = low level

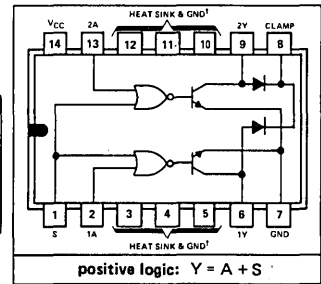

### SN75419

### NE DUAL-IN-LINE PACKAGE (TOP VIEW)

FUNCTION TABLE  
(EACH NOR DRIVER)

INPUTS		OUTPUT
A	S	Y
L	L	H
L	H	L
H	L	L
H	H	L

H = high level  
L = low level

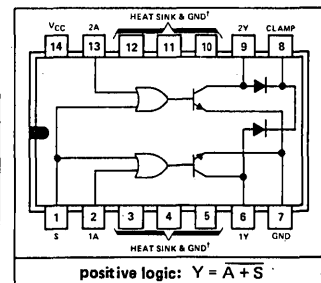

<sup>†</sup>Heat-sink pins are internally connected to pin 7.

Copyright © 1980 by Texas Instruments Incorporated

TEXAS INSTRUMENTS  
INCORPORATED

POST OFFICE BOX 225012 • DALLAS, TEXAS 75265

# SERIES 75416

## DUAL PERIPHERAL DRIVERS

absolute maximum ratings over operating free-air temperature range (unless otherwise noted)

Supply voltage, $V_{CC}$ (see Note 1)	7 V
Input voltage	5.5 V
Continuous output current (see Note 2)	550 mA
Peak output current: $t_w \leq 10$ ms, duty cycle $\leq 40\%$	1 A
$t_w \leq 30$ ns, duty cycle $\leq 0.002\%$	3 A
Output clamp diode current	550 mA
Continuous total dissipation at (or below) 25°C free-air temperature (see Note 3)	2 W
Operating free-air temperature	0°C to 70°C
Storage temperature range	-65°C to 150°C

recommended operating conditions

	MIN	NOM	MAX	UNIT
Supply voltage, $V_{CC}$	4.75	5	5.25	V
Operating free-air temperature	0		70	°C

NOTES: 1. Voltage values are with respect to network ground terminal.

2. Both halves of this dual circuit may conduct rated current simultaneously; however, power dissipation averaged over a short time interval must fall within the continuous dissipation ratings.

3. For operation above 25°C free-air temperature, refer to Dissipation Derating curves in the Thermal Information Section, which starts on page 2-1.

electrical characteristics over recommended operating free-air temperature range (unless otherwise noted)

PARAMETER		TEST CONDITIONS	MIN	TYP†	MAX	UNIT	
$V_{IH}$	High-level input voltage		2			V	
$V_{IL}$	Low-level input voltage				0.8	V	
$V_{IK}$	Input clamp voltage	$I_I = -12$ mA	-0.95		-1.5	V	
$I_{OH}$	High-level output current	$V_{CC} = 4.75$ V, $V_{IH} = 2$ V, $V_{IL} = 0.8$ V, $V_{OH} = 70$ V		1	100	μA	
$V_{OL}$	Low-level output voltage	$V_{CC} = 4.75$ V, $I_{OL} = 100$ mA		0.16	0.3	V	
		$V_{IH} = 2$ V, $I_{OL} = 300$ mA		0.33	0.6		
		$V_{IL} = 0.8$ V, $I_{OL} = 500$ mA		0.5	1.1		
$V_{(BR)O}$	Output breakdown voltage	$V_{CC} = 4.75$ V, $I_{OH} = 100$ μA	70	100		V	
$V_{R(K)}$	Output clamp diode reverse voltage	$V_{CC} = 4.75$ V, $I_R = 100$ μA	70	100		V	
$V_{F(K)}$	Output clamp diode forward voltage	$V_{CC} = 4.75$ V, $I_F = 500$ mA	0.8	1.25	1.6	V	
$I_{IH}$	High-level input current	$V_{CC} = 5.25$ V, $V_I = 5.5$ V		0.01	10	μA	
$I_{IL}$	Low-level input current	A input		-80	-110	μA	
		Strobe S	$V_{CC} = 5.25$ V, $V_I = 0.8$ V	-160	-220		
$I_{CCH}$	Supply current, outputs high	SN75416	$V_{CC} = 5.25$ V	$V_I = 5$ V	20	35	mA
		SN75417		$V_I = 0$	20	35	
		SN75418		$V_I = 5$ V	20	35	
		SN75419		$V_I = 0$	20	35	
$I_{CCL}$	Supply current, outputs low	SN75416	$V_{CC} = 5.25$ V	$V_I = 0$	75	130	mA
		SN75417		$V_I = 5$ V	75	130	
		SN75418		$V_I = 0$	75	130	
		SN75419		$V_I = 5$ V	75	130	

† All typical values are at  $V_{CC} = 5$  V,  $T_A = 25^\circ\text{C}$ .

switching characteristics,  $V_{CC} = 5\text{ V}$ ,  $T_A = 25^\circ\text{ C}$

PARAMETER	TEST CONDITIONS	SN75416			SN75417			SN75418			SN75419			UNIT
		MIN	TYP	MAX	MIN	TYP	MAX	MIN	TYP	MAX	MIN	TYP	MAX	
$t_{PLH}$ Propagation delay time, low-to-high-level output	$C_L = 30\text{ pF}$ , $R_L = 100\ \Omega$ , See Figure 1	100	200		100	200		100	200		100	200		ns
$t_{PHL}$ Propagation delay time, high-to-low-level output		200	300		200	300		200	300		200	300		ns
$t_{TLH}$ Transition time, low-to-high-level output		50	100		50	100		50	100		50	100		ns
$t_{THL}$ Transition time, high-to-low-level output		50	100		50	100		50	100		50	100		ns
$V_{OH}$ High-level output voltage after switching	$V_S = 55\text{ V}$ , $I_O \approx 500\text{ mA}$ , See Figure 2	$V_S - 11$			$V_S - 11$			$V_S - 11$			$V_S - 11$			mV

PARAMETER MEASUREMENT INFORMATION

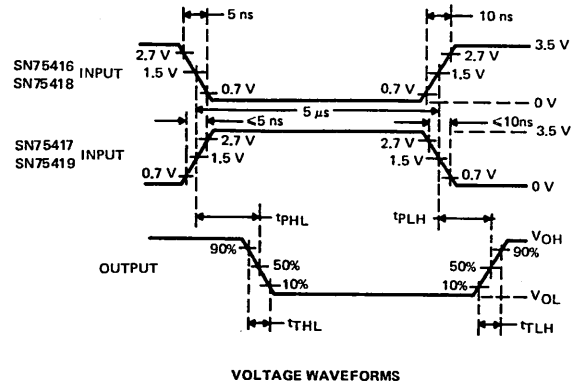
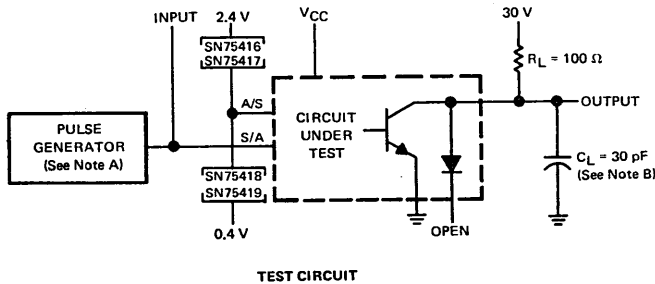

NOTES: A. The pulse generator has the following characteristics: PRR = 1 MHz,  $Z_{out} = 50\ \Omega$ .  
B.  $C_L$  includes probe and jig capacitance.

FIGURE 1—SWITCHING CHARACTERISTICS

# SERIES 75416 DUAL PERIPHERAL DRIVERS

## PARAMETER MEASUREMENT INFORMATION

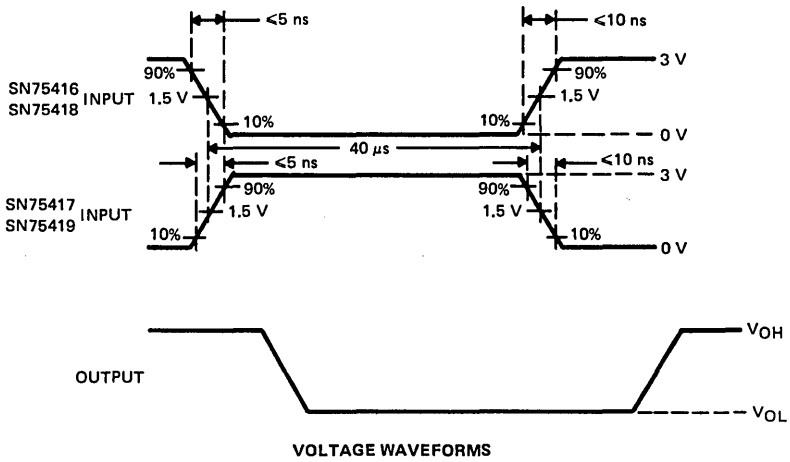
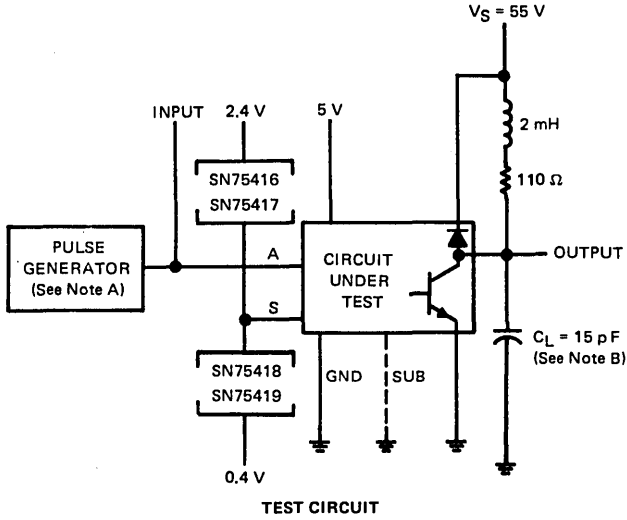

NOTES: A. The pulse generator has the following characteristics: PRR = 12.5 kHz,  $Z_{out} = 50\ \Omega$ .  
B.  $C_L$  includes probe and jig capacitance.

FIGURE 2—LATCH-UP TEST

**PERIPHERAL DRIVERS FOR  
HIGH-CURRENT SWITCHING AT VERY HIGH SPEEDS**

**performance**

- Characterized for Use to 300 mA
- No Output Latch-Up at 15 V (After Conducting 150 mA)
- Very-High-Speed Switching

**ease-of-design**

- Circuit Flexibility for Varied Applications and Choice of Logic Function
- TTL- or DTL-Compatible Diode-Clamped Inputs
- Standard Supply Voltages
- P-N Junctions Protected by Silicon Nitride
- Available in Plastic and Ceramic Packages

**SUMMARY OF SERIES 75430**

DEVICE	LOGIC OF COMPLETE CIRCUIT	PACKAGES
SN75430	Positive-AND <sup>†</sup>	J, N
SN75431	Positive-AND	JG, P
SN75432	Positive-NAND	JG, P
SN75433	Positive-OR	JG, P
SN75434	Positive-NOR	JG, P

<sup>†</sup>With output transistor base connected externally to output of gate.

**description**

Series 75430 dual peripheral drivers are a family of versatile devices designed for use in systems that employ TTL or DTL logic. Diode-clamped inputs simplify circuit design. They are mechanically interchangeable with the popular Series 75450B, Series 75460, and Series 75470 peripheral drivers. Typical applications include very-high-speed logic buffers, line drivers, MOS drivers, memory drivers, and power drivers. Series 75430 drivers are characterized for operation from 0°C to 70°C.

The SN75430 is a unique general-purpose device featuring two standard Series 54/74 TTL gates and two uncommitted, high-current, high-voltage n-p-n transistors. This device offers the system designer the flexibility of tailoring the circuit to the application.

The SN75431, SN75432, SN75433, and SN75434 are dual peripheral AND, NAND, OR, and NOR drivers, respectively, (assuming positive logic) with the output of the logic gates internally connected to the bases of the n-p-n output transistors.

CONTENTS	PAGE
Maximum Ratings and Recommended Operating Conditions . . . . .	4-30
Definitive Specifications	
Type SN75430 . . . . .	4-31
Type SN75431 . . . . .	4-33
Type SN75432 . . . . .	4-34
Type SN75433 . . . . .	4-35
Type SN75434 . . . . .	4-36
Switching Time Test Circuits and Voltage Waveforms . . . . .	4-37

# SERIES 75430

## DUAL PERIPHERAL DRIVERS

absolute maximum ratings over operating free-air temperature range (unless otherwise noted)

	SN75430	SN75431 SN75432 SN75433 SN75434	UNIT	
Supply voltage, $V_{CC}$ (see Note 1)	7	7	V	
Input voltage	5.5	5.5	V	
Interemitter voltage (see Note 2)	5.5	5.5	V	
$V_{CC}$ -to-substrate voltage	15		V	
Collector-to-substrate voltage	15		V	
Collector-base voltage	15		V	
Collector-emitter voltage (see Note 3)	15		V	
Emitter-base voltage	5		V	
Off-state output voltage		15	V	
Continuous collector or output current (see Note 4)	400	400	mA	
Peak collector or output current ( $t_W \leq 10$ ms, duty cycle $\leq 50\%$ , see Note 4)	500	500	mA	
Continuous total dissipation at (or below) 25°C free-air temperature (see Note 5)	J package	1025	mW	
	JG package	825		
	N package	1150		
	P package	1000		
Operating free-air temperature range	0 to 70	0 to 70	°C	
Storage temperature range	-65 to 150	-65 to 150	°C	
Lead temperature 1/16 inch from case for 60 seconds	J or JG package	300	300	°C
Lead temperature 1/16 inch from case for 10 seconds	N or P package	260	260	°C

- NOTES: 1. Voltage values are with respect to network ground terminal unless otherwise specified.  
 2. This is the voltage between two emitters of a multiple-emitter transistor.  
 3. This value applies when the base-emitter resistance ( $R_{BE}$ ) is equal to or less than 500  $\Omega$ .  
 4. Both halves of these dual circuits may conduct rated current simultaneously; however, power dissipation averaged over a short time interval must fall within the continuous dissipation rating.  
 5. For operation above 25°C free-air temperature, refer to Dissipation Derating Curves in the Thermal Information Section, which starts on page 2-1. In the J and JG packages, SN75430 through SN75434 chips are glass-mounted.

recommended operating conditions (see Note 6)

	MIN	NOM	MAX	UNIT
Supply voltage, $V_{CC}$	4.75	5	5.25	V
Operating free-air temperature, $T_A$	0		70	°C

NOTE 6: For the SN75430 only, the substrate (pin 8) must always be at the most-negative device voltage for proper operation.

# TYPE SN75430 DUAL PERIPHERAL POSITIVE-AND DRIVER

schematic

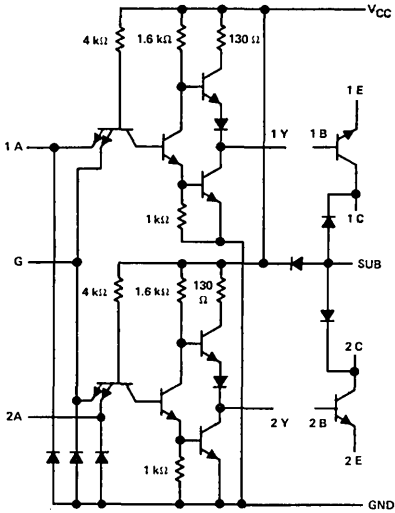

Resistor values shown are nominal.

J O R N  
DUAL-IN-LINE PACKAGE (TOP VIEW)

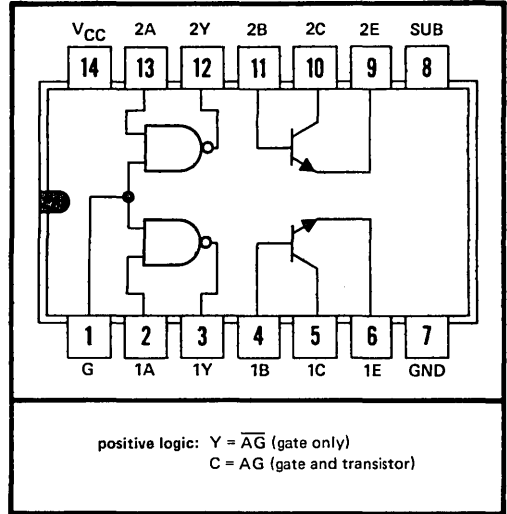

electrical characteristics over recommended operating free-air temperature range (unless otherwise noted)

TTL gates

PARAMETER		TEST CONDITIONS	MIN	TYP <sup>‡</sup>	MAX	UNIT
V <sub>IH</sub>	High-level input voltage		2			V
V <sub>IL</sub>	Low-level input voltage				0.8	V
V <sub>IK</sub>	Input clamp voltage	V <sub>CC</sub> = 4.75 V, I <sub>I</sub> = -12 mA			-1.5	V
V <sub>OH</sub>	High-level output voltage	V <sub>CC</sub> = 4.75 V, V <sub>IL</sub> = 0.8 V, I <sub>OH</sub> = -400 μA	2.4	3.3		V
V <sub>OL</sub>	Low-level output voltage	V <sub>CC</sub> = 4.75 V, V <sub>IH</sub> = 2 V, I <sub>OL</sub> = 16 mA		0.22	0.4	V
I <sub>I</sub>	Input current at maximum input voltage	input A			1	mA
		input G			2	
I <sub>IH</sub>	High-level input current	input A			40	μA
		input G			80	
I <sub>IL</sub>	Low-level input current	input A			-1.6	mA
		input G			-3.2	
I <sub>OS</sub>	Short-circuit output current <sup>§</sup>	V <sub>CC</sub> = 5.25 V	-18		-55	mA
I <sub>CCH</sub>	Supply current, outputs high	V <sub>CC</sub> = 5.25 V, V <sub>I</sub> = 0		2	4	mA
I <sub>CCL</sub>	Supply current, outputs low	V <sub>CC</sub> = 5.25 V, V <sub>I</sub> = 5 V		6	11	mA

<sup>‡</sup>All typical values are at V<sub>CC</sub> = 5 V, T<sub>A</sub> = 25°C.

<sup>§</sup>Not more than one output should be shorted at a time.

**TEXAS INSTRUMENTS**  
INCORPORATED

POST OFFICE BOX 225012 • DALLAS, TEXAS 75265

# TYPE SN75430

## DUAL PERIPHERAL POSITIVE-AND DRIVER

electrical characteristics over recommended operating free-air temperature range (unless otherwise noted)

### output transistors

PARAMETER		TEST CONDITIONS		MIN	TYP†	MAX	UNIT
$V_{(BR)CBO}$	Collector-Base Breakdown Voltage	$I_C = 100 \mu A$ ,	$I_E = 0$	15			V
$V_{(BR)CER}$	Collector-Emitter Breakdown Voltage	$I_C = 100 \mu A$ ,	$R_{BE} = 500 \Omega$	15			V
$V_{(BR)EBO}$	Emitter-Base Breakdown Voltage	$I_E = 100 \mu A$ ,	$I_C = 0$	5			V
$h_{FE}$	Static Forward Current Transfer Ratio	$V_{CE} = 3 V$ ,	$I_C = 100 mA$ ,	See Note 7	25		
		$T_A = 25^\circ C$					
		$V_{CE} = 3 V$ ,	$I_C = 300 mA$ ,		30		
		$T_A = 25^\circ C$					
		$V_{CE} = 3 V$ ,	$I_C = 100 mA$ ,		20		
		$T_A = 0^\circ C$			25		
$V_{BE}$	Base-Emitter Voltage	$I_B = 10 mA$ ,	$I_C = 100 mA$	See Note 7	0.85	1	V
		$I_B = 30 mA$ ,	$I_C = 300 mA$		1.05	1.2	
$V_{CE(sat)}$	Collector-Emitter Saturation Voltage	$I_B = 10 mA$ ,	$I_C = 100 mA$	See Note 7	0.25	0.4	V
		$I_B = 30 mA$ ,	$I_C = 300 mA$		0.5	0.7	

† All typical values are at  $V_{CC} = 5 V$ ,  $T_A = 25^\circ C$ .

NOTE 7: These parameters must be measured using pulse techniques.  $t_w = 300 \mu s$ , duty cycle  $\leq 2\%$ .

### switching characteristics, $V_{CC} = 5 V$ , $T_A = 25^\circ C$

#### TTL gates

PARAMETER	TEST FIGURE	TEST CONDITIONS	MIN	TYP	MAX	UNIT
$t_{PLH}$	1	$C_L = 15 pF$ , $R_L = 400 \Omega$	9	20		ns
$t_{PHL}$			7	13		ns

#### output transistors

PARAMETER	TEST FIGURE	TEST CONDITIONS†	MIN	TYP	MAX	UNIT
$t_d$	2	$I_C = 100 mA$ , $I_{B(1)} = 20 mA$ , $I_{B(2)} = -40 mA$ , $V_{BE(off)} = -1 V$ , $C_L = 15 pF$ , $R_L = 50 \Omega$	7	14		ns
$t_r$			10	19		ns
$t_s$			7	15		ns
$t_f$			6	15		ns

† Voltage and current values shown are nominal; exact values vary slightly with transistor parameters.

#### gates and transistors combined

PARAMETER	TEST FIGURE	TEST CONDITIONS	MIN	TYP	MAX	UNIT
$t_{PLH}$	3	$I_C \approx 100 mA$ , $C_L = 15 pF$ , $R_L = 50 \Omega$	15	26		ns
$t_{PHL}$			15	26		ns
$t_{TLH}$			7	12		ns
$t_{THL}$			9	15		ns
$V_{OH}$	4	$V_S = 15 V$ , $I_C \approx 150 mA$ , $R_{BE} = 500 \Omega$	$V_S - 10$			mV



# TYPE SN75431 DUAL PERIPHERAL POSITIVE-AND DRIVER

logic

**FUNCTION TABLE  
(EACH DRIVER)**

A	B	Y
L	L	L (on state)
L	H	L (on state)
H	L	L (on state)
H	H	H (off state)

H = high level, L = low level

JG OR P  
DUAL-IN-LINE PACKAGE (TOP VIEW)

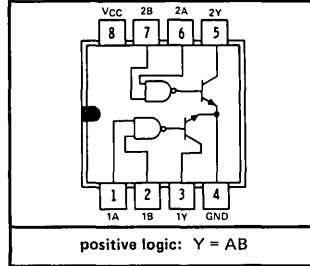

schematic (each driver)

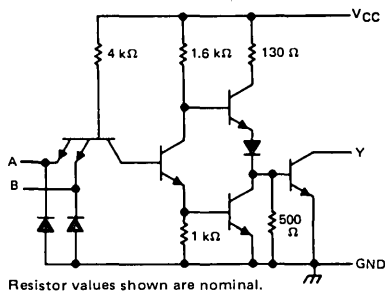

electrical characteristics over recommended operating free-air temperature range (unless otherwise noted)

PARAMETER	TEST CONDITIONS	MIN	TYP <sup>‡</sup>	MAX	UNIT
$V_{IH}$ High-level input voltage		2			V
$V_{IL}$ Low-level input voltage				0.8	V
$V_{IK}$ Input clamp voltage	$V_{CC} = 4.75 \text{ V}$ , $I_I = -12 \text{ mA}$			-1.5	V
$I_{OH}$ High-level output current	$V_{CC} = 4.75 \text{ V}$ , $V_{IH} = 2 \text{ V}$ , $V_{OH} = 15 \text{ V}$			100	$\mu\text{A}$
$V_{OL}$ Low-level output voltage	$V_{CC} = 4.75 \text{ V}$ , $V_{IL} = 0.8 \text{ V}$ , $I_{OL} = 100 \text{ mA}$		0.25	0.4	V
	$V_{CC} = 4.75 \text{ V}$ , $V_{IL} = 0.8 \text{ V}$ , $I_{OL} = 300 \text{ mA}$		0.5	0.7	
$I_I$ Input current at maximum input voltage	$V_{CC} = 5.25 \text{ V}$ , $V_I = 5.5 \text{ V}$			1	mA
$I_{IH}$ High-level input current	$V_{CC} = 5.25 \text{ V}$ , $V_I = 2.4 \text{ V}$			40	$\mu\text{A}$
$I_{IL}$ Low-level input current	$V_{CC} = 5.25 \text{ V}$ , $V_I = 0.4 \text{ V}$		-1	-1.6	mA
$I_{CCH}$ Supply current, outputs high	$V_{CC} = 5.25 \text{ V}$ , $V_I = 5 \text{ V}$		7	11	mA
$I_{CCL}$ Supply current, outputs low	$V_{CC} = 5.25 \text{ V}$ , $V_I = 0$		52	65	mA

<sup>‡</sup>All typical values are at  $V_{CC} = 5 \text{ V}$ ,  $T_A = 25^\circ\text{C}$ .

switching characteristics,  $V_{CC} = 5 \text{ V}$ ,  $T_A = 25^\circ\text{C}$

PARAMETER	TEST FIGURE	TEST CONDITIONS	MIN	TYP	MAX	UNIT
$t_{PLH}$ Propagation delay time, low-to-high-level output	3	$I_O \approx 100 \text{ mA}$ , $C_L = 15 \text{ pF}$ , $R_L = 50 \Omega$		10	20	ns
$t_{PHL}$ Propagation delay time, high-to-low-level output				17	25	ns
$t_{TLH}$ Transition time, low-to-high-level output				5	8	ns
$t_{THL}$ Transition time, high-to-low-level output				8	12	ns
$V_{OH}$ High-level output voltage after switching	4	$V_S = 15 \text{ V}$ , $I_O \approx 150 \text{ mA}$	$V_S - 10$			mV

**TEXAS INSTRUMENTS**  
INCORPORATED

POST OFFICE BOX 225012 • DALLAS, TEXAS 75265

# TYPE SN75432

## DUAL PERIPHERAL POSITIVE-NAND DRIVER

logic

FUNCTION TABLE  
(EACH DRIVER)

A	B	Y
L	L	H (off state)
L	H	H (off state)
H	L	H (off state)
H	H	L (on state)

H = high level, L = low level

JG OR P  
DUAL-IN-LINE PACKAGE (TOP VIEW)

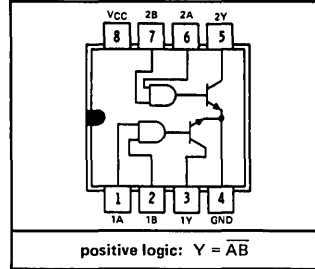

schematic (each driver)

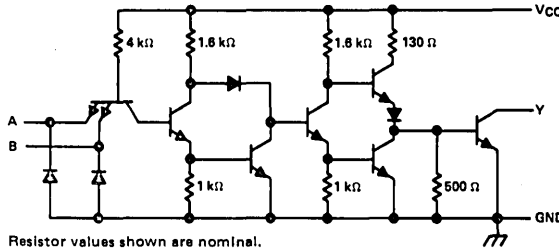

electrical characteristics over recommended operating free-air temperature range (unless otherwise noted)

PARAMETER	TEST CONDITIONS	MIN	TYP <sup>‡</sup>	MAX	UNIT	
V <sub>IH</sub>	High-level input voltage	2			V	
V <sub>IL</sub>	Low-level input voltage			0.8	V	
V <sub>IK</sub>	Input clamp voltage			-1.5	V	
I <sub>OH</sub>	High-level output current			100	μA	
V <sub>OL</sub>	Low-level output voltage	V <sub>CC</sub> = 4.75 V, V <sub>IH</sub> = 2 V, I <sub>OL</sub> = 100 mA	0.25	0.4	V	
		V <sub>CC</sub> = 4.75 V, V <sub>IH</sub> = 2 V, I <sub>OL</sub> = 300 mA	0.5	0.7		
I <sub>I</sub>	Input current at maximum input voltage			1	mA	
I <sub>IH</sub>	High-level input current			40	μA	
I <sub>IL</sub>	Low-level input current			-1	-1.6	mA
I <sub>CCH</sub>	Supply current, outputs high			11	14	mA
I <sub>CCL</sub>	Supply current, outputs low			56	71	mA

<sup>‡</sup>All typical values are at V<sub>CC</sub> = 5 V, T<sub>A</sub> = 25°C.

switching characteristics, V<sub>CC</sub> = 5 V, T<sub>A</sub> = 25°C

PARAMETER	TEST FIGURE	TEST CONDITIONS	MIN	TYP	MAX	UNIT
t <sub>PLH</sub>	3	I <sub>O</sub> ≈ 100 mA, C <sub>L</sub> = 15 pF, R <sub>L</sub> = 50 Ω	15	25		ns
t <sub>PHL</sub>			19	25		ns
t <sub>TLH</sub>			5	8		ns
t <sub>THL</sub>			8	12		ns
V <sub>OH</sub>	4	V <sub>S</sub> = 15 V, I <sub>O</sub> ≈ 150 mA	V <sub>S</sub> -10			mV

# TYPE SN75433

## DUAL PERIPHERAL POSITIVE-OR DRIVER

logic

**FUNCTION TABLE  
(EACH DRIVER)**

A	B	Y
L	L	L (on state)
L	H	H (off state)
H	L	H (off state)
H	H	H (off state)

H = high level, L = low level

**JG OR P  
DUAL-IN-LINE PACKAGE (TOP VIEW)**

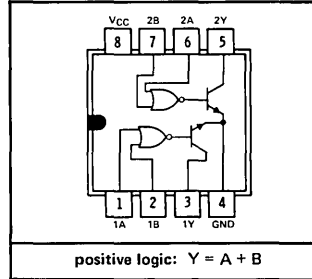

schematic (each driver)

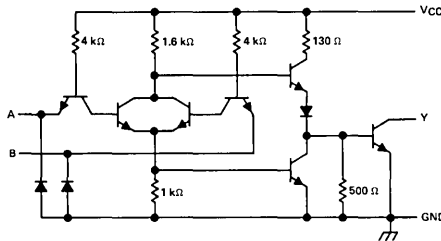

Resistor values shown are nominal.

electrical characteristics over recommended operating free-air temperature range (unless otherwise noted)

PARAMETER	TEST CONDITIONS	MIN	TYP <sup>‡</sup>	MAX	UNIT
V <sub>IH</sub> High-level input voltage		2			V
V <sub>IL</sub> Low-level input voltage				0.8	V
V <sub>IK</sub> Input clamp voltage	V <sub>CC</sub> = 4.75 V, I <sub>I</sub> = -12 mA			-1.5	V
I <sub>OH</sub> High-level output current	V <sub>CC</sub> = 4.75 V, V <sub>IH</sub> = 2 V, V <sub>OH</sub> = 15 V			100	μA
V <sub>OL</sub> Low-level output voltage	V <sub>CC</sub> = 4.75 V, V <sub>IL</sub> = 0.8 V, I <sub>OL</sub> = 100 mA		0.25	0.4	V
	V <sub>CC</sub> = 4.75 V, V <sub>IL</sub> = 0.8 V, I <sub>OL</sub> = 300 mA		0.5	0.7	
I <sub>I</sub> Input current at maximum input voltage	V <sub>CC</sub> = 5.25 V, V <sub>I</sub> = 5.5 V			1	mA
I <sub>IH</sub> High-level input current	V <sub>CC</sub> = 5.25 V, V <sub>I</sub> = 2.4 V			40	μA
I <sub>IL</sub> Low-level input current	V <sub>CC</sub> = 5.25 V, V <sub>I</sub> = 0.4 V		-1	-1.6	mA
I <sub>CCH</sub> Supply current, outputs high	V <sub>CC</sub> = 5.25 V, V <sub>I</sub> = 5 V		8	11	mA
I <sub>CCL</sub> Supply current, outputs low	V <sub>CC</sub> = 5.25 V, V <sub>I</sub> = 0		54	68	mA

<sup>‡</sup>All typical values are at V<sub>CC</sub> = 5 V, T<sub>A</sub> = 25°C.

switching characteristics, V<sub>CC</sub> = 5 V, T<sub>A</sub> = 25°C

PARAMETER	TEST FIGURE	TEST CONDITIONS	MIN	TYP	MAX	UNIT
t <sub>PLH</sub> Propagation delay time, low-to-high-level output	3	I <sub>O</sub> ≈ 100 mA, C <sub>L</sub> = 15 pF, R <sub>L</sub> = 50 Ω		10	20	ns
t <sub>PHL</sub> Propagation delay time, high-to-low-level output				15	25	ns
t <sub>TLH</sub> Transition time, low-to-high-level output				3	8	ns
t <sub>THL</sub> Transition time, high-to-low-level output				9	12	ns
V <sub>OH</sub> High-level output voltage after switching	4	V <sub>S</sub> = 15 V, I <sub>O</sub> ≈ 150 mA	V <sub>S</sub> -10			mV

**TEXAS INSTRUMENTS**  
INCORPORATED

POST OFFICE BOX 225012 • DALLAS, TEXAS 75265

# TYPE SN75434

## DUAL PERIPHERAL POSITIVE-NOR DRIVER

logic

FUNCTION TABLE  
(EACH DRIVER)

A	B	Y
L	L	H (off state)
L	H	L (on state)
H	L	L (on state)
H	H	L (on state)

H = high level, L = low level

JG OR P  
DUAL-IN-LINE PACKAGE (TOP VIEW)

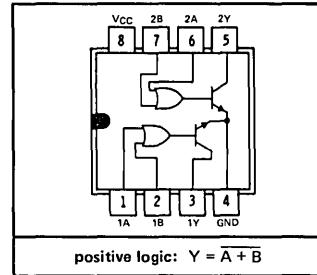

schematic (each driver)

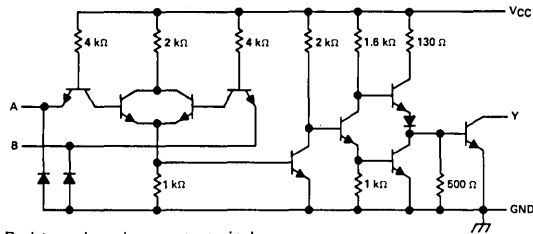

electrical characteristics over recommended operating free-air temperature range (unless otherwise noted)

PARAMETER	TEST CONDITIONS	MIN	TYP†	MAX	UNIT
$V_{IH}$ High-level input voltage		2			V
$V_{IL}$ Low-level input voltage				0.8	V
$V_{IK}$ Input clamp voltage	$V_{CC} = 4.75 \text{ V}$ , $I_I = -12 \text{ mA}$			-1.5	V
$I_{OH}$ High-level output current	$V_{CC} = 4.75 \text{ V}$ , $V_{IL} = 0.8 \text{ V}$ , $V_{OH} = 15 \text{ V}$			100	$\mu\text{A}$
$V_{OL}$ Low-level output voltage	$V_{CC} = 4.75 \text{ V}$ , $V_{IH} = 2 \text{ V}$ , $I_{OL} = 100 \text{ mA}$		0.25	0.4	V
	$V_{CC} = 4.75 \text{ V}$ , $V_{IH} = 2 \text{ V}$ , $I_{OL} = 300 \text{ mA}$		0.5	0.7	
$I_I$ Input current at maximum input voltage	$V_{CC} = 5.25 \text{ V}$ , $V_I = 5.5 \text{ V}$			1	mA
$I_{IH}$ High-level input current	$V_{CC} = 5.25 \text{ V}$ , $V_I = 2.4 \text{ V}$			40	$\mu\text{A}$
$I_{IL}$ Low-level input current	$V_{CC} = 5.25 \text{ V}$ , $V_I = 0.4 \text{ V}$		-1	-1.6	mA
$I_{CCH}$ Supply current, outputs high	$V_{CC} = 5.25 \text{ V}$ , $V_I = 0$		13	17	mA
$I_{CCL}$ Supply current, outputs low	$V_{CC} = 5.25 \text{ V}$ , $V_I = 5 \text{ V}$		61	79	mA

†All typical values are at  $V_{CC} = 5 \text{ V}$ ,  $T_A = 25^\circ \text{C}$ .

switching characteristics,  $V_{CC} = 5 \text{ V}$ ,  $T_A = 25^\circ \text{C}$

PARAMETER	TEST FIGURE	TEST CONDITIONS	MIN	TYP	MAX	UNIT
$t_{PLH}$ Propagation delay time, low-to-high-level output	3	$I_O \approx 100 \text{ mA}$ , $C_L = 15 \text{ pF}$ , $R_L = 50 \Omega$		13	25	ns
$t_{PHL}$ Propagation delay time, high-to-low-level output				17	25	ns
$t_{TLH}$ Transition time, low-to-high-level output				5	8	ns
$t_{THL}$ Transition time, high-to-low-level output				8	12	ns
$V_{OH}$ High-level output voltage after switching	4	$V_S = 15 \text{ V}$ , $I_O \approx 150 \text{ mA}$	$V_S - 10$			mV

# SERIES 75430 DUAL PERIPHERAL DRIVERS

## PARAMETER MEASUREMENT INFORMATION

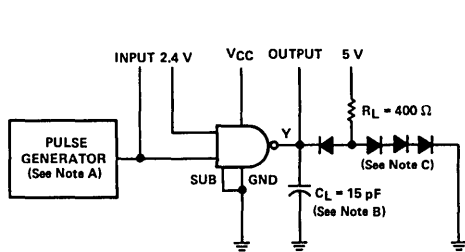

TEST CIRCUIT

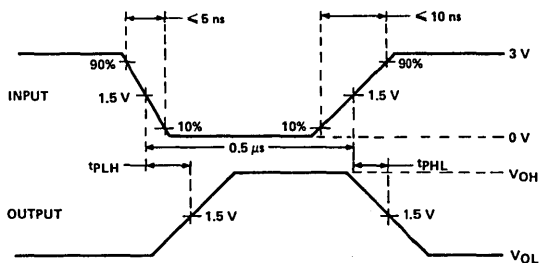

VOLTAGE WAVEFORMS

- NOTES: A. The pulse generator has the following characteristics: PRR = 1 MHz,  $Z_{out} \approx 50 \Omega$ .  
 B.  $C_L$  include probe and jig capacitance.  
 C. All diodes are 1N3064.

FIGURE 1—PROPAGATION DELAY TIMES, EACH GATE (SN75430 ONLY)

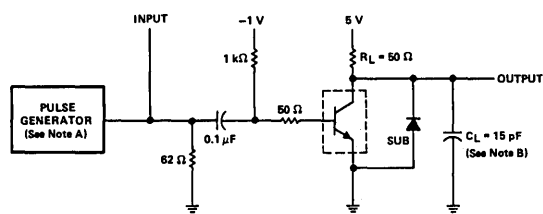

TEST CIRCUIT

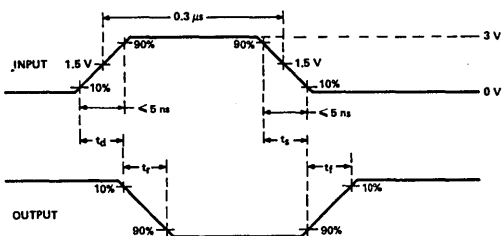

VOLTAGE WAVEFORMS

- NOTES: A. The pulse generator has the following characteristics: duty cycle  $\leq 1\%$ ,  $Z_{out} \approx 50 \Omega$ .  
 B.  $C_L$  includes probe and jig capacitance.

FIGURE 2—SWITCHING TIMES, EACH TRANSISTOR (SN75430 ONLY)

# SERIES 75430 DUAL PERIPHERAL DRIVERS

## PARAMETER MEASUREMENT INFORMATION

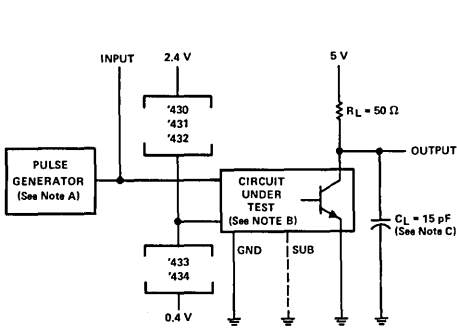

TEST CIRCUIT

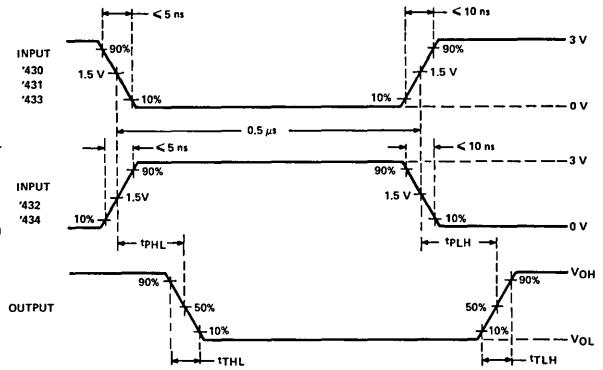

VOLTAGE WAVEFORMS

- NOTES: A. The pulse generator has the following characteristics: PRR = 1 MHz,  $Z_{out} \approx 50 \Omega$ .  
 B. When testing SN75430, connect output Y to transistor base and ground the substrate terminal.  
 C.  $C_L$  includes probe and jig capacitance.

FIGURE 3—SWITCHING TIMES OF COMPLETE DRIVERS

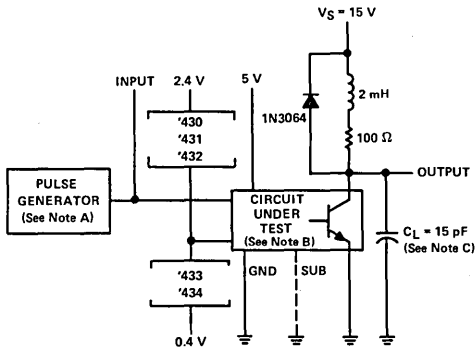

TEST CIRCUIT

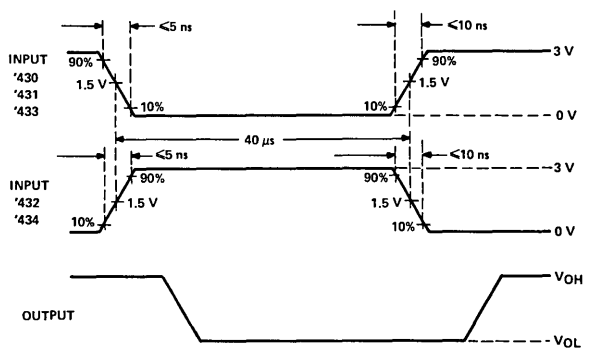

VOLTAGE WAVEFORMS

- NOTES: A. The pulse generator has the following characteristics: PRR = 12.5 kHz,  $Z_{out} = 50 \Omega$ .  
 B. When testing SN75430, connect output Y to transistor base with a 500- $\Omega$  resistor from there to ground, and ground the substrate terminal.  
 C.  $C_L$  includes probe and jig capacitance.

FIGURE 4—LATCH-UP TEST OF COMPLETE DRIVERS

# INTERFACE CIRCUITS

# TYPE SN75437 QUADRUPLE PERIPHERAL DRIVERS

BULLETIN NO. DL-S 12795, DECEMBER 1980

- Low Saturation Voltage
- Very Low Power Requirements
- Very Low Input Current
- Characterized for Use to 500 mA
- No Output Latch-Up at 35 V (After Conducting 500 mA)
- High-Voltage Outputs (70 V Min)
- Output Clamp Diodes for Transient Suppression (500 mA, 70 V)
- TTL- or MOS-Compatible Diode-Clamped Inputs
- Standard Supply Voltage
- Suitable for Hammer-Driver Applications
- 2-W Power Package
  - Low  $R_{\theta JA} \dots 60^{\circ}\text{C/W}$
  - Low  $R_{\theta JC} \dots 10^{\circ}\text{C/W}$

### description

The SN75437 Quad peripheral driver is designed for use in systems that require high current, high voltage, and high power. The SN75437 provides NAND drivers. These devices have diode-clamped inputs as well as high-current, high-voltage clamp diodes on the outputs.

### schematic of inputs and functional block diagram

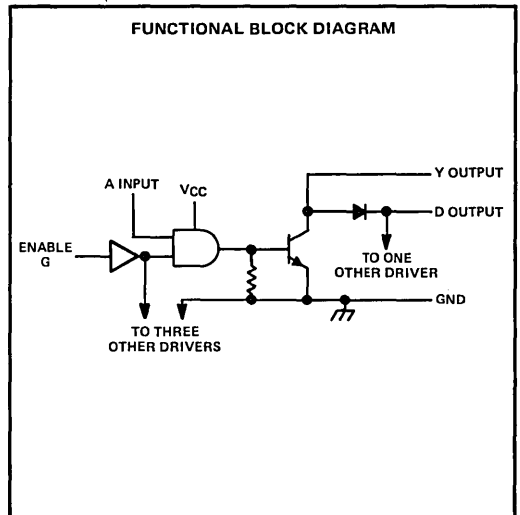
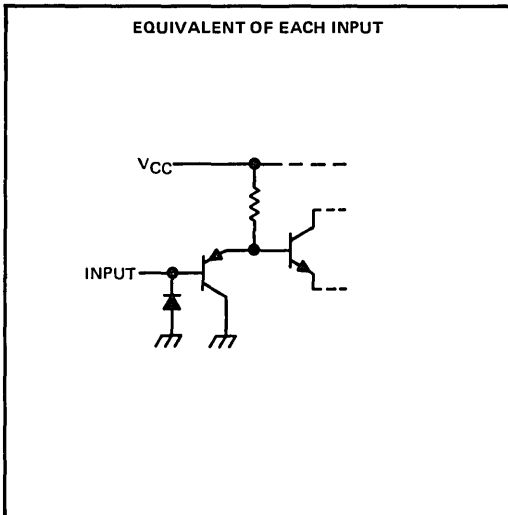

NE DUAL-IN-LINE PACKAGE  
(TOP VIEW)

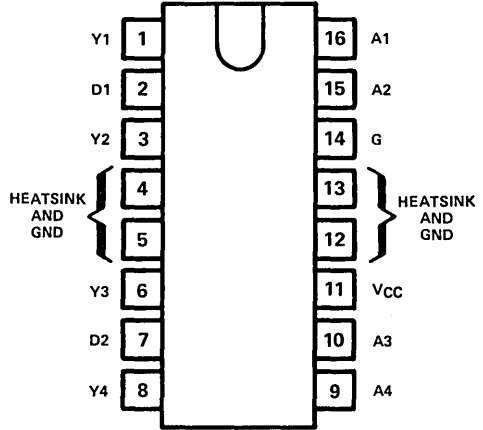

FUNCTION TABLE  
(EACH NAND DRIVER)

INPUTS		OUTPUT
A	G	Y
L	X	H
X	L	H
H	H	L

H = high level, L = low level  
X = Irrelevant

# TYPE SN75437

## QUADRUPLE PERIPHERAL DRIVERS

absolute maximum ratings over operating free-air temperature range (unless otherwise noted)

Supply voltage, $V_{CC}$ (see Note 1)	7 V
Input voltage	5.5 V
Output current (see Note 2)	600 mA
Output clamp diode current	600 mA
Continuous total dissipation at (or below) 25°C free-air temperature (see Note 3)	2075 mW
Operating free-air temperature	0°C to 70°C
Storage temperature range	-65°C to 150°C
Lead temperature 1/16 inch from case for 60 seconds: JG package	300°C
Lead temperature 1/16 inch from case for 10 seconds: P package	250°C

recommended operating conditions

	MIN	NOM	MAX	UNIT
Supply voltage, $V_{CC}$	4.75	5	5.25	V
Operating free-air temperature, $T_A$	0		70	°C

NOTES: 1. Voltage values are with respect to network ground terminal.

2. All sections of this quad circuit may conduct rated current simultaneously, however power dissipation averaged over a short time interval must fall within the continuous dissipation ratings.

3. For operation above 25°C free-air temperature, derate linearly to 1328 mW at 70°C at the rate of 16.6 mW/°C.

electrical characteristics over recommended operating free-air temperature range (unless otherwise noted)

PARAMETER	TEST CONDITIONS	MIN	TYP†	MAX	UNIT
$V_{IH}$ High-level input voltage		2			V
$V_{IL}$ Low-level input voltage				0.8	V
$V_{IK}$ Input clamp voltage	$V_{CC} = 4.75$ V, $I_I = 12$ mA	0.9		1.5	V
$I_{OH}$ High-level output current	$V_{CC} = 4.75$ V, $V_{IH} = 2$ V, $V_{OL} = 0.8$ V, $V_{OH} = 70$ V		1	100	μA
$V_{OL}$ Low-level output voltage	$V_{CC} = 4.75$ V, $V_{IH} = 2$ V	$I_{OL} = 200$ mA	0.15	0.5	V
		$I_{OL} = 400$ mA	0.30	0.6	
		$I_{OL} = 500$ mA	0.45	0.7	
$V_{(BR)O}$ Output breakdown voltage	$V_{CC} = 4.75$ V, $I_{OH} = 100$ μA	70	100		V
$V_{R(D)}$ Output clamp diode reverse voltage	$V_{CC} = 4.75$ V, $I_R = 100$ μA	70	100		V
$V_{F(D)}$ Output clamp diode forward voltage	$V_{CC} = 4.75$ V, $I_F = 500$ mA	0.6	1.2	1.6	V
$I_{IH}$ High-level input current	$V_{CC} = 5.25$ V, $V_I = 5.25$ V		0.01	10	μA
$I_{IL}$ Low-level input current	$V_{CC} = 5.25$ V, $V_I = 0.8$ V		-0.5	-10	μA
$I_{CCH}$ Supply current, outputs high	$V_{CC} = 5.25$ V, $V_I = 0$		40	65	mA
$I_{CCL}$ Supply current, outputs low	$V_{CC} = 5.25$ V, $V_I = 5$ V		40	65	mA

† All typical values are at  $V_{CC} = 5$  V,  $T_A = 25^\circ$  C.

switching characteristics,  $V_{CC} = 5$  V,  $T_A = 25^\circ$  C

PARAMETER†	TEST CONDITIONS	MIN	TYP	MAX	UNIT	
$t_{PLH}$ Propagation delay time, low-to-high-level output	$C_L = 30$ pF, $R_L = 60$ Ω, See Figure 1		750		ns	
$t_{PHL}$ Propagation delay time, high-to-low-level output			750		ns	
$t_{TLH}$ Transition time, low-to-high-level output				200		ns
$t_{THL}$ Transition time, high-to-low-level output				200		ns
$V_{OH}$ High-level output voltage after switching	$V_S = 35$ V, $I_O \approx 500$ mA, See Figure 2	$V_S - 10$			mV	



# TYPE SN75437 QUADRUPLE PERIPHERAL DRIVERS

## PARAMETER MEASUREMENT INFORMATION

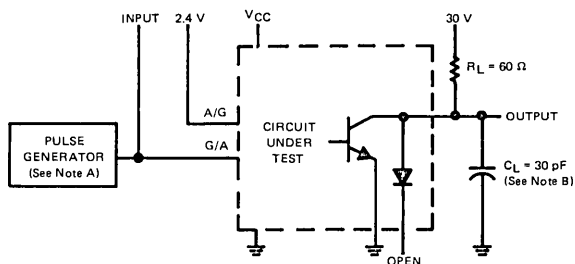

TEST CIRCUIT

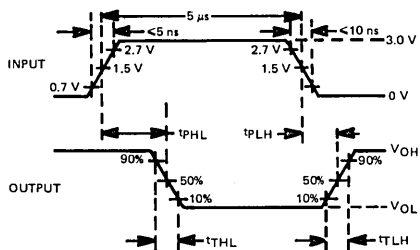

VOLTAGE WAVEFORMS

NOTES: A. The pulse generator has the following characteristics: PRR = 100 kHz,  $Z_{out} = 50 \Omega$ .  
B.  $C_L$  includes probe and jig capacitance.

FIGURE 1—SWITCHING CHARACTERISTICS

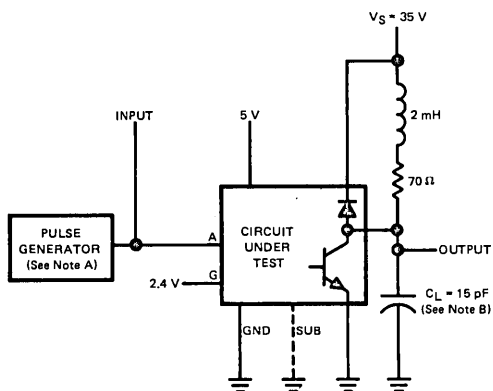

TEST CIRCUIT

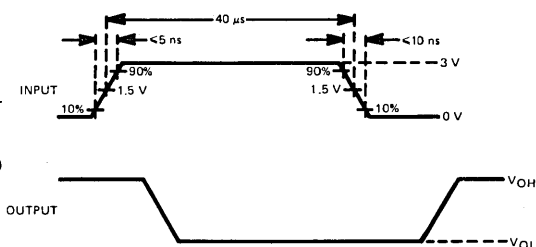

VOLTAGE WAVEFORMS

NOTES: A. The pulse generator has the following characteristics: PRR = 12.5 kHz,  $Z_{out} = 50 \Omega$ .  
B.  $C_L$  includes probe and jig capacitance.

FIGURE 2—LATCH-UP TEST

TEXAS INSTRUMENTS  
INCORPORATED

POST OFFICE BOX 225012 • DALLAS, TEXAS 75265



# INTERFACE CIRCUITS

# TYPE SN75441 DUAL ECL-COMPATIBLE PERIPHERAL DRIVER

BULLETIN NO. DL-S 12479, DECEMBER 1976—REVISED AUGUST 1977

- Characterized For Use To 100 mA
- No Output Latch-Up at 20 V (After Conducting 100 mA)
- High-Speed Switching
- Positive OR Logic
- Versatile Interface Circuits for Use Between ECL and High-Current, High-Voltage Systems
- Inputs are Compatible with Series 10000 ECL and Other Similar ECL Families
- Standard Supply Voltages

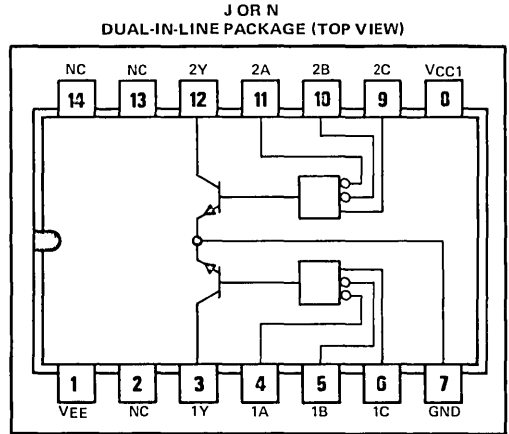

NC—No internal connection

## description

The SN75441 is a monolithic dual ECL-compatible peripheral driver and interface circuit. The device accepts standard input signals from ECL families and provides high-current and high-voltage output levels suitable for driving MOS and TTL circuits. Typical applications include high-speed logic buffers, line drivers, MOS drivers, and memory drivers.

The device has one in-phase and two out-of-phase ECL-compatible inputs per driver. By proper connections of the inputs, the SN75441 may be used three ways: positive-OR gate, differential ECL line receiver, or inverting gate. Some applications require one input per gate to be connected to an externally generated ECL reference voltage,  $V_{BB}$ .

The SN75441 operates from two standard supplies, the TTL  $V_{CC}$  supply and the ECL  $V_{EE}$  supply, and is characterized for operation from 0°C to 70°C.

FUNCTION TABLE

DIFFERENTIAL (More positive of A or B)—C	LOGIC LEVEL			OUTPUT Y
	A	B	C	
H ( $V_{ID} \geq 150$ mV)	L	H	L	H
H ( $V_{ID} \geq 150$ mV)	H	L	L	H
? ( $-150$ mV $\leq V_{ID} \leq 150$ mV)	X	X	X	INDETERMINATE
L ( $V_{ID} \leq -150$ mV)	L	L	H	L

H = high level, L = low level, X = irrelevant  
See additional function tables in Figure 3.

## schematics of inputs and outputs

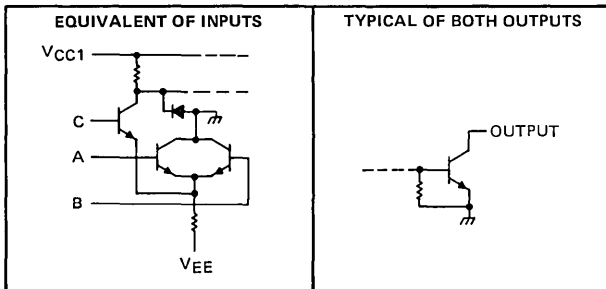

**TEXAS INSTRUMENTS**  
INCORPORATED

POST OFFICE BOX 225012 • DALLAS, TEXAS 75265

# TYPE SN75441

## DUAL ECL-COMPATIBLE PERIPHERAL DRIVER

absolute maximum ratings over operating free-air temperature range (unless otherwise noted)

Supply voltage range of $V_{CC}$ (see Note 1)	-0.5 V to 7 V
Supply voltage range of $V_{EE}$	-7 V to 0.5 V
Negative voltage at $V_{CC}$ with respect to $V_{EE}$	-0.5 V
Input voltage range	-7 V to 0.5 V
Negative voltage at any input with respect to $V_{EE}$	-1 V
Differential input voltage	5.5 V
Off-state output voltage	30 V
Output current	150 mA
Continuous total dissipation at (or below) 25°C free-air temperature (see Note 2):	
J package	1025 mW
N package	1150 mW
Operating free-air temperature range	0°C to 70°C
Storage temperature range	-65°C to 150°C
Lead temperature 1/16 inch from case for 60 seconds: J package	300°C
Lead temperature 1/16 inch from case for 10 seconds: N package	260°C

- NOTES : 1. Voltage values are with respect to network ground terminal unless otherwise noted.  
 2. For operation above 25°C free-air temperature, refer to the Dissipation Derating Curves in the Thermal Information Section, which starts on page 2-1. In the J package, the SN75441 chip is glass-mounted.

### recommended operating conditions

	MIN	NOM	MAX	UNIT
Supply voltage, $V_{CC}$	4.75	5	5.25	V
Supply voltage, $V_{EE}$	-4.68	-5.2	-5.72	V
Operating free-air temperature, $T_A$	0		70	°C

### definition of input logic levels (see Note 3)

PARAMETER	B	A	UNIT
	(Least Positive)	(Most Positive)	
$V_{IH}$ High-level input voltage at any input	-1.5	-0.7	V
$V_{IL}$ Low-level input voltage at any input	$V_{EE}$	$V_{IH}-150$ mV	
$V_{IDH}$ High-level differential input voltage (see Note 3)	150		mV
$V_{IDL}$ Low-level differential input voltage (see Note 3)		-150	mV

NOTE 3: Differential input voltage is the voltage at the more positive Inverting Input (A or B) with respect to the nonInverting Input (C) of the same gate.

# TYPE SN75441

## DUAL ECL-COMPATIBLE PERIPHERAL DRIVER

electrical characteristics over recommended ranges of  $V_{CC}$ ,  $V_{EE}$ , and operating free-air temperature (unless otherwise noted)

PARAMETER	TEST CONDITIONS	MIN	TYP†	MAX	UNIT
$I_{OH}$ High-level output current	$V_{CC} = 4.75 \text{ V}$ , $V_{IDH} = 150 \text{ mV}$ , $V_{OH} = 30 \text{ V}$			100	$\mu\text{A}$
$V_{OL}$ Low-level output voltage	$V_{CC} = 4.75 \text{ V}$ , $V_{IDL} = -150 \text{ mV}$	$I_{OL} = 10 \text{ mA}$	0.15	0.3	V
		$I_{OL} = 100 \text{ mA}$	0.35	0.5	
$I_{IH}$ High-level input current	$V_{EE} = -5.72 \text{ V}$ , $V_I = -0.7 \text{ V}$ , All other inputs at $-5.72 \text{ V}$		300	800	$\mu\text{A}$
$I_{IL}$ Low-level input current	$V_{EE} = -5.72 \text{ V}$ , All other inputs at $-0.7 \text{ V}$	$V_I = -2 \text{ V}$		-10	$\mu\text{A}$
		$V_I = -5.72 \text{ V}$		-100	
$I_{CC(H)}$ Supply current from $V_{CC}$ , all outputs high	$V_{CC} = 5.25 \text{ V}$ , $V_{EE} = -5.72 \text{ V}$ , All A and B inputs at $-0.7 \text{ V}$ , Both C inputs at $-2 \text{ V}$ , No load, $T_A = 25^\circ\text{C}$		15	22	mA
$I_{EE(H)}$ Supply current from $V_{EE}$ , all outputs high			-21	-30	
$I_{CC(L)}$ Supply current from $V_{CC}$ , all outputs low	$V_{CC} = 5.25 \text{ V}$ , $V_{EE} = -5.72 \text{ V}$ , All A and B inputs at $-2 \text{ V}$ , Both C inputs at $-0.7 \text{ V}$ , No load, $T_A = 25^\circ\text{C}$		40	56	mA
$I_{EE(L)}$ Supply current from $V_{EE}$ , all outputs low			-21	-30	

† All typical values are at  $V_{CC} = 5 \text{ V}$ ,  $V_{EE} = -5.2 \text{ V}$ , and  $T_A = 25^\circ\text{C}$ .

switching characteristics,  $V_{CC} = 5 \text{ V}$ ,  $V_{EE} = -5.2 \text{ V}$ ,  $T_A = 25^\circ\text{C}$

PARAMETER	TEST CONDITIONS	MIN	TYP	MAX	UNIT
$t_{TLH}$ Transition time, low-to-high-level output	$C_L = 15 \text{ pF}$ , $R_L = 50 \Omega$ , $I_O \approx 100 \text{ mA}$ , See Figure 1		7	12	ns
$t_{THL}$ Transition time, high-to-low-level output			11	16	
$t_{PLH}$ Propagation delay time, low-to-high-level output			19	25	
$t_{PHL}$ Propagation delay time high-to-low-level output			22	30	
$V_{OH}$ High-level output voltage after switching	$V_S = 20 \text{ V}$ , $I_O \approx 100 \text{ mA}$ , See Figure 2	$V_S - 20$			mV

### PARAMETER MEASUREMENT INFORMATION

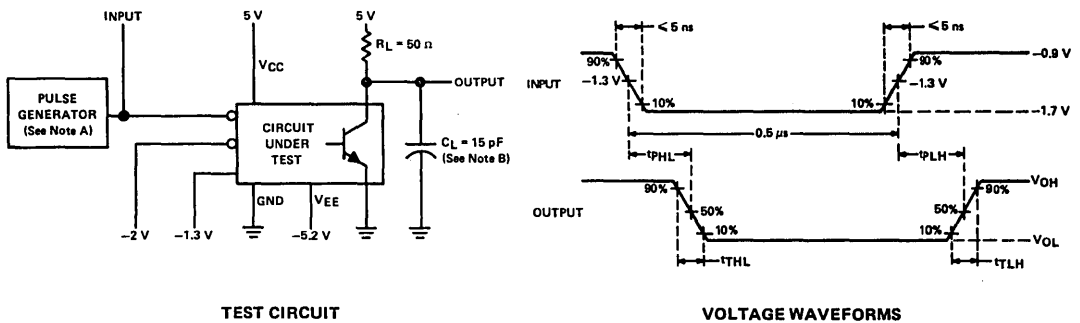

NOTES: A. The pulse generator has the following characteristics: PRR = 1 MHz,  $Z_{out} \approx 50 \Omega$ .  
B.  $C_L$  Includes probe and jig capacitance.

FIGURE 1 – SWITCHING TIMES, EACH DRIVER

# TYPE SN75441 DUAL ECL-COMPATIBLE PERIPHERAL DRIVER

## PARAMETER MEASUREMENT INFORMATION

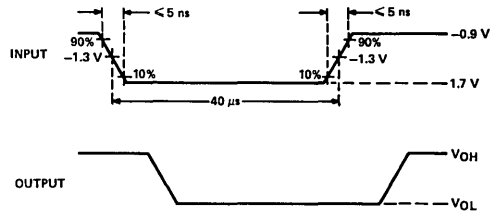
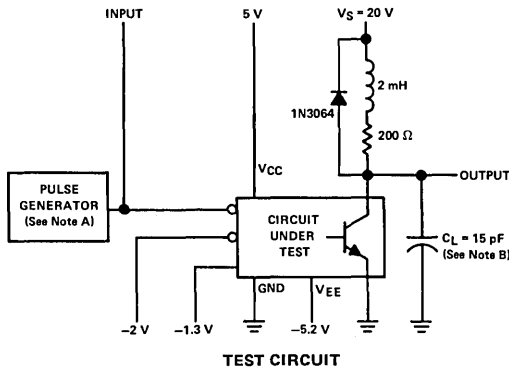

TEST CIRCUIT

VOLTAGE WAVEFORMS

NOTES: A. The pulse generator has the following characteristics: PRR = 12.5 kHz,  $Z_{out} \approx 50 \Omega$ .  
B.  $C_L$  includes probe and jig capacitance.

FIGURE 2—LATCH-UP TEST, EACH DRIVER

## TYPICAL APPLICATION DATA

### positive-OR gate

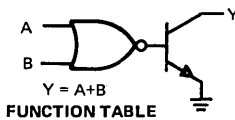

FUNCTION TABLE

CONFIGURATION	INPUTS			OUTPUT
	A	B	C	
C at $V_{BB}$	L	L	$V_{BB}$	L
	H	X	$V_{BB}$	H
	X	H	$V_{BB}$	H

### inverting gate

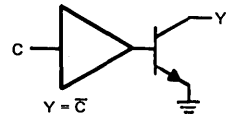

FUNCTION TABLE

CONFIGURATION	INPUTS			OUTPUT
	A	B	C	
A and B at $V_{BB}$	$V_{BB}$	$V_{BB}$	L	H
	$V_{BB}$	$V_{BB}$	H	L
A at $V_{BB}$ , B connected low	$V_{BB}$	L	L	H
B at $V_{BB}$ , A connected low	L	$V_{BB}$	L	H
A and B connected low	L	L	H	L

### differential ECL line receiver

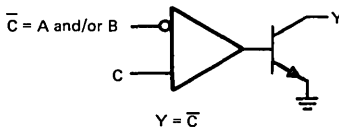

FUNCTION TABLE

CONFIGURATION	INPUTS			OUTPUT
	A	B	C	
A and B connected together	H	H	L	H
	L	L	H	L
A not used but connected low	L	H	L	H
B not used but connected low	H	L	L	H
A and B connected low	L	L	H	L

H = high level, L = low level, X = irrelevant  
 $V_{BB}$  = Reference Supply voltage for SN10000 Series ECL.

The one in-phase (C) and two out-of-phase (A and B) inputs per driver permit much flexibility when using the SN75441. By connecting the correct input to an externally generated  $V_{BB}$  (ECL reference supply voltage), positive-OR gate or inverting gate functions may be obtained. The  $V_{BB}$  reference voltage may be generated by connecting the output of any ECL gate to its out-of-phase input, by using the  $V_{BB}$  pin of certain ECL devices such as SN10115, or by other methods. By driving the correct inputs differentially, these devices may be used as differential ECL line receivers and no  $V_{BB}$  reference voltage is required. An unused out-of-phase input may be connected low or connected to the other out-of-phase input of the same gate in many applications.

FIGURE 3—FUNCTIONS

# INTERFACE CIRCUITS

# SERIES 75446 DUAL PERIPHERAL DRIVERS

BULLETIN NO. DL-S 12630, DECEMBER 1978 — REVISED NOVEMBER 1980

- Very Low Power Requirements
- Very Low Input Current
- Characterized for Use to 350 mA
- No Output Latch-Up at 50 V (After Conducting 300 mA)
- High-Voltage Outputs (70 V Min)
- Output Clamp Diodes for Transient Suppression (350 mA, 70 V)
- TTL- or MOS-Compatible Diode-Clamped Inputs
- Standard Supply Voltage
- Suitable for Hammer-Driver Applications

### description

Series 75446 dual peripheral drivers are designed for use in systems that require high current, high voltage, and fast switching times. The SN75446, SN75447, SN75448, and SN75449 provide AND, NAND, OR, and NOR drivers, respectively. These devices have diode-clamped inputs as well as high-current, high-voltage inductive-clamp diodes on the outputs.

Series 75446 drivers are characterized for operation from 0°C to 70°C.

### schematics of inputs and outputs

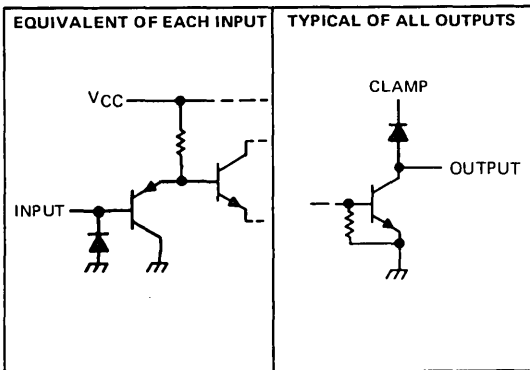

SN75446  
FUNCTION TABLE  
(EACH AND DRIVER)

INPUTS		OUTPUT
A	S	Y
L	L	L
L	H	L
H	L	L
H	H	H

H = high level  
L = low level

SN75447  
FUNCTION TABLE  
(EACH NAND DRIVER)

INPUTS		OUTPUT
A	S	Y
L	L	H
L	H	H
H	L	H
H	H	L

H = high level  
L = low level

SN75448  
FUNCTION TABLE  
(EACH OR DRIVER)

INPUTS		OUTPUT
A	S	Y
L	L	L
L	H	H
H	L	H
H	H	H

H = high level  
L = low level

SN75449  
FUNCTION TABLE  
(EACH NOR DRIVER)

INPUTS		OUTPUT
A	S	Y
L	L	H
L	H	L
H	L	L
H	H	L

H = high level  
L = low level

JG OR P DUAL-IN-LINE PACKAGE

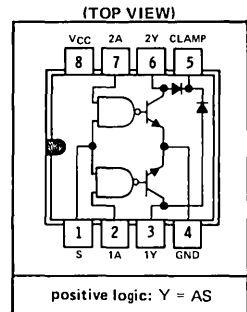

JG OR P DUAL-IN-LINE PACKAGE

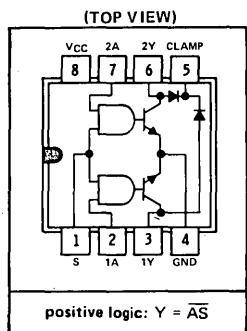

JG OR P DUAL-IN-LINE PACKAGE

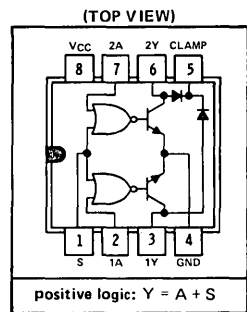

JG OR P DUAL-IN-LINE PACKAGE

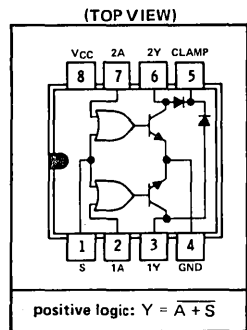

Copyright © 1980 by Texas Instruments Incorporated

TEXAS INSTRUMENTS  
INCORPORATED

POST OFFICE BOX 225012 • DALLAS, TEXAS 75285

# SERIES 75446

## DUAL PERIPHERAL DRIVERS

absolute maximum ratings over operating free-air temperature range (unless otherwise noted)

Supply voltage, $V_{CC}$ (see Note 1)	7 V
Input voltage	5.5 V
Output current (see Note 2)	400 mA
Output clamp diode current	400 mA
Continuous total dissipation at (or below) 25°C free-air temperature (see Note 3):	
JG package	825 mW
P package	1000 mW
Operating free-air temperature	0°C to 70°C
Storage temperature range	-65°C to 150°C
Lead temperature 1/16 inch from case for 60 seconds: JG package	300°C
Lead temperature 1/16 inch from case for 10 seconds: P package	260°C

recommended operating conditions

	MIN	NOM	MAX	UNIT
Supply voltage, $V_{CC}$	4.75	5	5.25	V
Operating free-air temperature	0		70	°C

- NOTES: 1. Voltage values are with respect to network ground terminal.  
 2. Both halves of this dual circuit may conduct rated current simultaneously; however, power dissipation averaged over a short time interval must fall within the continuous dissipation ratings.  
 3. For operation above 25°C free-air temperature, refer to Dissipation Derating Curves in the Thermal Information section, which starts on page 11. In the JG package, SN75446 through SN75449 chips are glass-mounted.

electrical characteristics over recommended operating free-air temperature range (unless otherwise noted)

PARAMETER		TEST CONDITIONS	MIN	TYP†	MAX	UNIT	
$V_{IH}$	High-level input voltage		2			V	
$V_{IL}$	Low-level input voltage				0.8	V	
$V_{IK}$	Input clamp voltage	$I_I = -12$ mA	-0.9		-1.5	V	
$I_{OH}$	High-level output current	$V_{CC} = 4.75$ V, $V_{IH} = 2$ V, $V_{IL} = 0.8$ V, $V_{OH} = 70$ V		1	100	μA	
$V_{OL}$	Low-level output voltage	$V_{CC} = 4.75$ V, $V_{IH} = 2$ V, $V_{IL} = 0.8$ V	$I_{OL} = 100$ mA	0.10	0.3	V	
			$I_{OL} = 200$ mA	0.22	0.45		
			$I_{OL} = 300$ mA	0.45	0.65		
			$I_{OL} = 350$ mA	0.65	0.75		
$V_{(BR)O}$	Output breakdown voltage	$V_{CC} = 4.75$ V, $I_{OH} = 100$ μA	70	100		V	
$V_{R(K)}$	Output clamp diode reverse voltage	$V_{CC} = 4.75$ V, $I_R = 100$ μA	70	100		V	
$V_{F(K)}$	Output clamp diode forward voltage	$V_{CC} = 4.75$ V, $I_F = 350$ mA	0.6	1.2	1.6	V	
$I_{IH}$	High-level input current	$V_{CC} = 5.25$ V, $V_I = 5.25$ V		0.01	10	μA	
$I_{IL}$	Low-level input current	A input	$V_{CC} = 5.25$ V, $V_I = 0.8$ V	-0.5	-10	μA	
		Strobe S		-1	-20		
$I_{CCH}$	Supply current, outputs high	SN75446	$V_{CC} = 5.25$ V,	$V_I = 5$ V	11	18	mA
		SN75447		$V_I = 0$	11	18	
		SN75448		$V_I = 5$ V	18	25	
		SN75449		$V_I = 0$	18	25	
$I_{CCL}$	Supply current, outputs low	SN75446	$V_{CC} = 5.25$ V	$V_I = 0$	11	18	mA
		SN75447		$V_I = 5$ V	11	18	
		SN75448		$V_I = 0$	18	25	
		SN75449		$V_I = 5$ V	18	25	

†All typical values are at  $V_{CC} = 5$  V,  $T_A = 25^\circ\text{C}$ .



switching characteristics,  $V_{CC} = 5\text{ V}$ ,  $T_A = 25^\circ\text{C}$

PARAMETER	TEST CONDITIONS	SN75446	SN75447	SN75448	SN75449	UNIT
		MIN TYP MAX	MIN TYP MAX	MIN TYP MAX	MIN TYP MAX	
$t_{PLH}$ Propagation delay time, low-to-high-level output	$C_L = 30\text{ pF}$ , $R_L = 100\ \Omega$ , See Figure 1	300 750	300 750	300 750	300 750	ns
$t_{PHL}$ Propagation delay time, high-to-low-level output		200 500	200 500	200 500	200 500	ns
$t_{TLH}$ Transition time, low-to-high-level output		50 100	50 100	50 100	50 100	ns
$t_{THL}$ Transition time, high-to-low-level output		50 100	50 100	50 100	50 100	ns
$V_{OH}$ High-level output voltage after switching	$V_S = 55\text{ V}$ , $I_O \approx 300\text{ mA}$ , See Figure 2	$V_S - 18$	$V_S - 18$	$V_S - 18$	$V_S - 18$	mV

PARAMETER MEASUREMENT INFORMATION

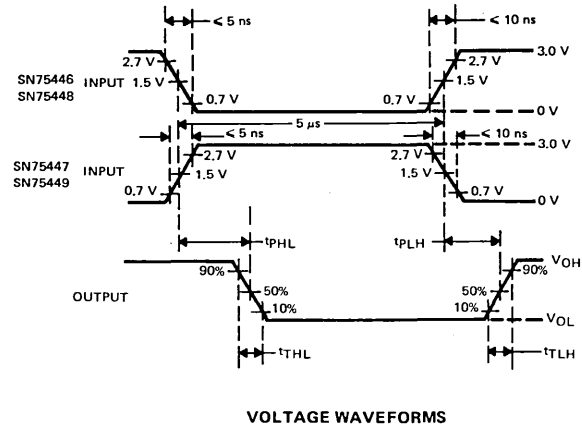
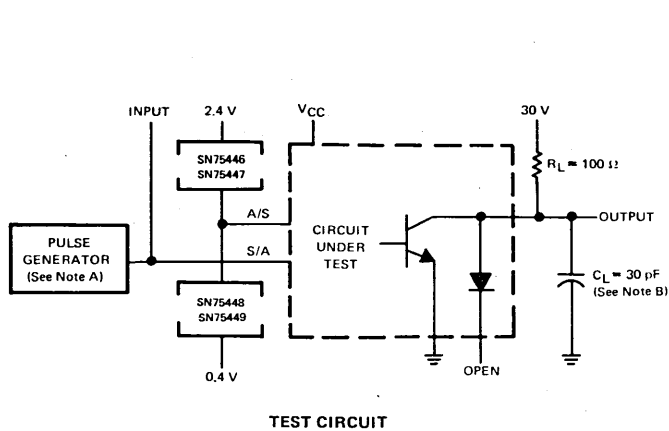

NOTES: A. The pulse generator has the following characteristics: PRR = 100 kHz,  $Z_{out} = 50\ \Omega$ .  
B.  $C_L$  includes probe and jig capacitance.

FIGURE 1—SWITCHING CHARACTERISTICS

TEXAS INSTRUMENTS  
INCORPORATED  
POST OFFICE BOX 2250112 • DALLAS, TEXAS 75285

SERIES 75446  
DUAL PERIPHERAL DRIVERS

# SERIES 75446 DUAL PERIPHERAL DRIVERS

## PARAMETER MEASUREMENT INFORMATION

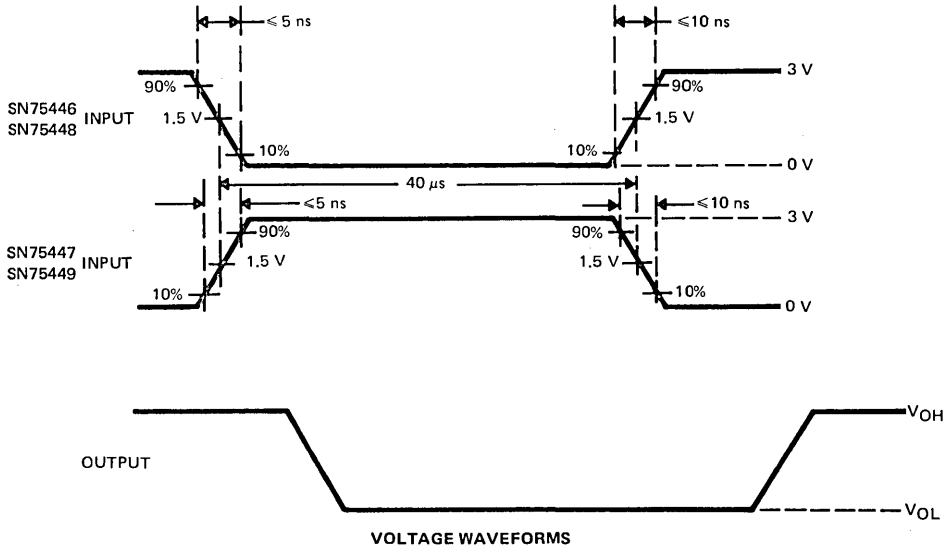
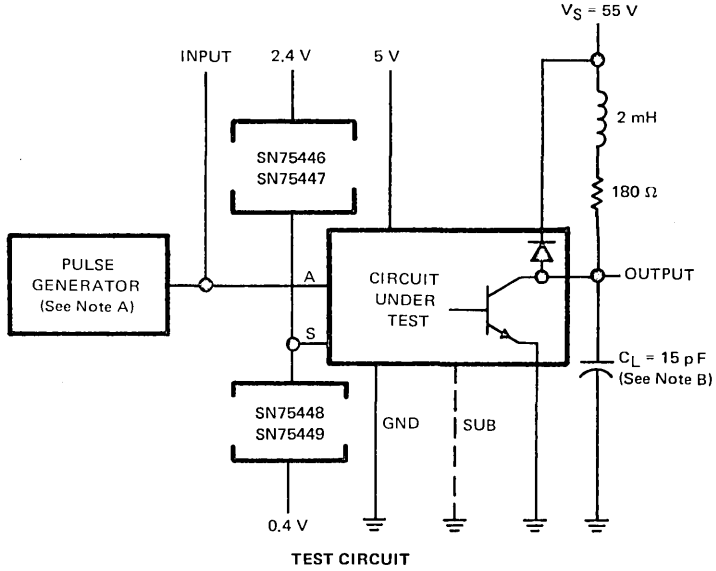

NOTES: A. The pulse generator has the following characteristics: PRR = 12.5 kHz,  $Z_{out} = 50 \Omega$ .  
B.  $C_L$  includes probe and jig capacitance.

**FIGURE 2—LATCH-UP TEST**

**PERIPHERAL DRIVERS FOR  
HIGH-CURRENT SWITCHING AT HIGH SPEEDS**

**performance**

- Characterized for Use to 300 mA
- High-Voltage Outputs
- No Output Latch-Up at 20 V (After Conducting 300 mA)
- High-Speed Switching

**ease-of-design**

- Circuit Flexibility for Varied Applications and Choice of Logic Function
- TTL- or DTL-Compatible Diode-Clamped Inputs
- Standard Supply Voltages
- Available in Plastic and Ceramic Packages

**SUMMARY OF SERIES 55450/75450**

DEVICE	LOGIC OF COMPLETE CIRCUIT	PACKAGES
SN55450B	AND <sup>†</sup>	J
SN55451B	AND	JG
SN55452B	NAND	JG
SN55453B	OR	JG
SN55454B	NOR	JG
SN75450B	AND <sup>†</sup>	J, N
SN75451B	AND	JG, P
SN75452B	NAND	JG, P
SN75453B	OR	JG, P
SN75454B	NOR	JG, P

<sup>†</sup>With output transistor base connected externally to output of gate.

**description**

Series 55450B/75450B dual peripheral drivers are a family of versatile devices designed for use in systems that employ TTL or DTL logic. The 55450B/75450B family is functionally interchangeable with and replaces the 75450 family and the 75450A family devices manufactured previously. The speed of the 55450B/75450B family is equal to that of the 75450 family and a test to ensure freedom from latch-up has been added. Diode-clamped inputs simplify circuit design. Typical applications include high-speed logic buffers, power drivers, relay drivers, lamp drivers, MOS drivers, line drivers, and memory drivers. Series 55450B drivers are characterized for operation over the full military temperature range of -55°C to 125°C; Series 75450B drivers are characterized for operation from 0°C to 70°C.

The SN55450B and SN75450B are unique general-purpose devices each featuring two standard Series 54/74 TTL gates and two uncommitted, high-current, high-voltage n-p-n transistors. These devices offer the system designer the flexibility of tailoring the circuit to the application.

The SN55451B/SN75451B, SN55452B/SN75452B, SN55453B/SN75453B, and SN55454B/SN75454B are dual peripheral AND, NAND, OR, and NOR drivers, respectively, (assuming positive logic) with the output of the logic gates internally connected to the bases of the n-p-n output transistors.

CONTENTS		PAGE
Maximum Ratings and Recommended Operating Conditions . . . . .		4-52
Definitive Specifications		
Types SN55450B, SN75450B . . . . .		4-53
Types SN55451B, SN75451B . . . . .		4-55
Types SN55452B, SN75452B . . . . .		4-56
Types SN55453B, SN75453B . . . . .		4-57
Types SN55454B, SN75454B . . . . .		4-58
Switching Time Test Circuits and Voltage Waveforms . . . . .		4-59
Typical Characteristics . . . . .		4-61

# SERIES 55450B/75450B

## DUAL PERIPHERAL DRIVERS

absolute maximum ratings over operating free-air temperature range (unless otherwise noted)

	SN55450B	SN55451B SN55452B SN55453B SN55454B	SN75450B	SN75451B SN75452B SN75453B SN75454B	UNIT
Supply voltage, $V_{CC}$ (see Note 1)	7	7	7	7	V
Input voltage	5.5	5.5	5.5	5.5	V
Interemitter voltage (see Note 2)	5.5	5.5	5.5	5.5	V
$V_{CC}$ -to-substrate voltage	35		35		V
Collector-to-substrate voltage	35		35		V
Collector-base voltage	35		35		V
Collector-emitter voltage (see Note 3)	30		30		V
Emitter-base voltage	5		5		V
Off-state output voltage		30		30	V
Continuous collector or output current (see Note 4)	400	400	400	400	mA
Peak collector or output current ( $t_w \leq 10$ ms, duty cycle $\leq 50\%$ , see Note 4)	500	500	500	500	mA
Continuous total dissipation at (or below) 25°C free-air temperature (see Note 5)	J package	1375	1025		mW
	JG package		1050	825	
	N package		1150		
	P package			1000	
Operating free-air temperature range	-55 to 125	-55 to 125	0 to 70	0 to 70	°C
Storage temperature range	-65 to 150	-65 to 150	-65 to 150	-65 to 150	°C
Lead temperature 1/16 inch from case for 60 seconds	J or JG package	300	300	300	°C
Lead temperature 1/16 inch from case for 10 seconds	N or P package	260	260	260	°C

- NOTES: 1. Voltage values are with respect to network ground terminal unless otherwise specified.  
 2. This is the voltage between two emitters of a multiple-emitter transistor.  
 3. This value applies when the base-emitter resistance ( $R_{BE}$ ) is equal to or less than 500  $\Omega$ .  
 4. Both halves of these dual circuits may conduct rated current simultaneously; however, power dissipation averaged over a short time interval must fall within the continuous dissipation rating.  
 5. For operation above 25°C free-air temperature, refer to Dissipation Derating Curves in the Thermal Information Section, which starts on page 2-1. In the J and JG packages, SN55450B through SN55454B chips are alloy-mounted; SN75450B through SN75454B chips are glass-mounted.

recommended operating conditions (see Note 6)

	SERIES 55450B			SERIES 75450B			UNIT
	MIN	NOM	MAX	MIN	NOM	MAX	
Supply voltage, $V_{CC}$	4.5	5	5.5	4.75	5	5.25	V
Operating free-air temperature, $T_A$	-55		125	0		70	°C

NOTE 6: For the SN55450B and SN75450B only, the substrate (pin 8) must always be at the most-negative device voltage for proper operation.

# TYPES SN55450B, SN75450B DUAL PERIPHERAL POSITIVE-AND DRIVERS

schematic

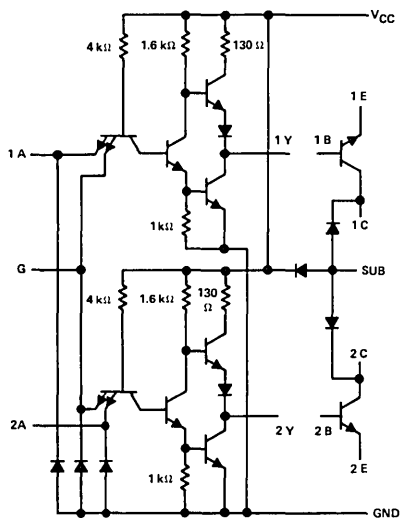

Resistor values shown are nominal.

SN55450B . . . J  
SN75450B . . . J OR N  
DUAL-IN-LINE PACKAGE (TOP VIEW)

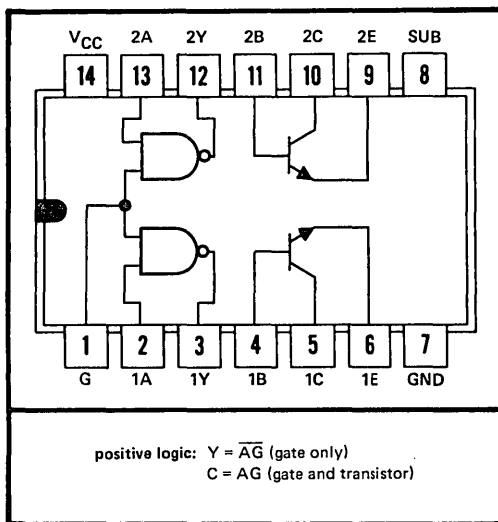

4

electrical characteristics over recommended operating free-air temperature range (unless otherwise noted)

TTL gates

PARAMETER	TEST CONDITIONS†	SN55450B		SN75450B		UNIT
		MIN	TYP‡ MAX	MIN	TYP‡ MAX	
$V_{IH}$ High-level input voltage		2		2		V
$V_{IL}$ Low-level input voltage			0.8		0.8	V
$V_{IK}$ Input clamp voltage	$V_{CC} = \text{MIN}, I_I = -12 \text{ mA}$	-1.2	-1.5	-1.2	-1.5	V
$V_{OH}$ High-level output voltage	$V_{CC} = \text{MIN}, V_{IL} = 0.8 \text{ V}, I_{OH} = -400 \mu\text{A}$	2.4	3.3	2.4	3.3	V
$V_{OL}$ Low-level output voltage	$V_{CC} = \text{MIN}, V_{IH} = 2 \text{ V}, I_{OL} = 16 \text{ mA}$	0.25	0.5	0.25	0.4	V
$I_I$ Input current at maximum input voltage	input A		1		1	mA
	input G		2		2	
$I_{IH}$ High-level input current	input A		40		40	$\mu\text{A}$
	input G		80		80	
$I_{IL}$ Low-level input current	input A		-1.6		-1.6	mA
	input G		-3.2		-3.2	
$I_{OS}$ Short-circuit output current §	$V_{CC} = \text{MAX}$	-18	-35 -55	-18	-35 -55	mA
$I_{CCH}$ Supply current, outputs high	$V_{CC} = \text{MAX}, V_I = 0$		2.8 4		2.8 4	mA
$I_{CCL}$ Supply current, outputs low	$V_{CC} = \text{MAX}, V_I = 5 \text{ V}$		7 11		7 11	mA

† For conditions shown as MIN or MAX, use the appropriate value specified under recommended operating conditions.

‡ All typical values at  $V_{CC} = 5 \text{ V}, T_A = 25^\circ\text{C}$ .

§ Not more than one output should be shorted at a time.

# TYPES SN55450B, SN75450B

## DUAL PERIPHERAL POSITIVE-AND DRIVERS

electrical characteristics over recommended operating free-air temperature range (unless otherwise noted)

### output transistors

PARAMETER	TEST CONDITIONS†	SN55450B		SN75450B		UNIT		
		MIN	TYP‡	MAX	MIN		TYP‡	MAX
V(BR)CBO	Collector-Base Breakdown Voltage $I_C = 100 \mu\text{A}, I_E = 0$	35			35		V	
V(BR)CER	Collector-Emitter Breakdown Voltage $I_C = 100 \mu\text{A}, R_{BE} = 500 \Omega$	30			30		V	
V(BR)EBO	Emitter-Base Breakdown Voltage $I_E = 100 \mu\text{A}, I_C = 0$	5			5		V	
hFE	Static Forward Current Transfer Ratio	See Note 7	$V_{CE} = 3 \text{ V}, I_C = 100 \text{ mA}, T_A = 25^\circ\text{C}$	25		25		
			$V_{CE} = 3 \text{ V}, I_C = 300 \text{ mA}, T_A = 25^\circ\text{C}$	30		30		
			$V_{CE} = 3 \text{ V}, I_C = 100 \text{ mA}, T_A = \text{MIN}$	10		20		
			$V_{CE} = 3 \text{ V}, I_C = 300 \text{ mA}, T_A = \text{MIN}$	15		25		
VBE	Base-Emitter Voltage	See Note 7	$I_B = 10 \text{ mA}, I_C = 100 \text{ mA}$	0.85	1.2	0.85	1	V
			$I_B = 30 \text{ mA}, I_C = 300 \text{ mA}$	1	1.4	1	1.2	
VCE(sat)	Collector-Emitter Saturation Voltage	See Note 7	$I_B = 10 \text{ mA}, I_C = 100 \text{ mA}$	0.25	0.5	0.25	0.4	V
			$I_B = 30 \text{ mA}, I_C = 300 \text{ mA}$	0.45	0.8	0.45	0.7	

†For conditions shown as MIN or MAX, use the appropriate value specified under recommended operating conditions.

‡All typical values are at  $V_{CC} = 5 \text{ V}, T_A = 25^\circ\text{C}$ .

NOTE 7: These parameters must be measured using pulse techniques.  $t_w = 300 \mu\text{s}$ , duty cycle  $\leq 2\%$ .

### switching characteristics, $V_{CC} = 5 \text{ V}, T_A = 25^\circ\text{C}$

#### TTL gates

PARAMETER	TEST CONDITIONS	MIN	TYP	MAX	UNIT
tPLH	$C_L = 15 \text{ pF}, R_L = 400 \Omega, \text{ See Figure 1}$	12		22	ns
tPHL		8		15	ns

#### output transistors

PARAMETER	TEST CONDITIONS‡	MIN	TYP	MAX	UNIT
t <sub>d</sub>	$I_C = 200 \text{ mA}, I_B(1) = 20 \text{ mA}, I_B(2) = -40 \text{ mA}, V_{BE}(\text{off}) = -1 \text{ V}, C_L = 15 \text{ pF}, R_L = 50 \Omega, \text{ See Figure 2}$	8		15	ns
t <sub>r</sub>		12		20	ns
t <sub>s</sub>		7		15	ns
t <sub>f</sub>		6		15	ns

‡Voltage and current values shown are nominal; exact values vary slightly with transistor parameters.

#### gates and transistors combined

PARAMETER	TEST CONDITIONS	MIN	TYP	MAX	UNIT
tPLH	$I_C \approx 200 \text{ mA}, C_L = 15 \text{ pF}, R_L = 50 \Omega, \text{ See Figure 3}$	20		30	ns
tPHL		20		30	ns
tTLH		7		12	ns
tTHL		9		15	ns
VOH	$V_S = 20 \text{ V}, I_C \approx 300 \text{ mA}, R_{BE} = 500 \Omega, \text{ See Figure 4}$	V <sub>S</sub> -6.5			mV

# TYPES SN55451B, SN75451B DUAL PERIPHERAL POSITIVE-AND DRIVERS

logic

FUNCTION TABLE  
(EACH DRIVER)

A	B	Y
L	L	L (on state)
L	H	L (on state)
H	L	L (on state)
H	H	H (off state)

H = high level, L = low level

SN55451B . . . JG  
SN75451B . . . JG OR P  
DUAL-IN-LINE PACKAGE (TOP VIEW)

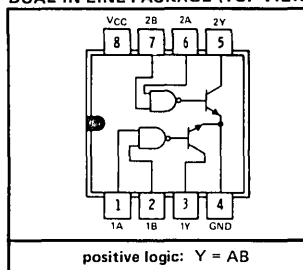

schematic (each driver)

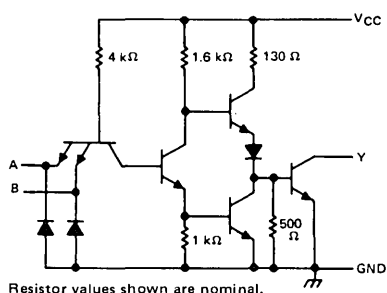

electrical characteristics over recommended operating free-air temperature range (unless otherwise noted)

PARAMETER	TEST CONDITIONS†	SN55451B			SN75451B			UNIT
		MIN	TYP‡	MAX	MIN	TYP‡	MAX	
$V_{IH}$	High-level input voltage	2			2			V
$V_{IL}$	Low-level input voltage	0.8			0.8			V
$V_{IK}$	Input clamp voltage	$V_{CC} = \text{MIN}, I_I = -12 \text{ mA}$			-1.2 -1.5			V
$I_{OH}$	High-level output current	$V_{CC} = \text{MIN}, V_{IH} = 2 \text{ V}, V_{OH} = 30 \text{ V}$			300			100 $\mu\text{A}$
$V_{OL}$	Low-level output voltage	$V_{CC} = \text{MIN}, V_{IL} = 0.8 \text{ V}, I_{OL} = 100 \text{ mA}$			0.25 0.5			V
		$V_{CC} = \text{MIN}, V_{IL} = 0.8 \text{ V}, I_{OL} = 300 \text{ mA}$			0.5 0.8			
$I_I$	Input current at maximum input voltage	$V_{CC} = \text{MAX}, V_I = 5.5 \text{ V}$			1			1 mA
$I_{IH}$	High-level input current	$V_{CC} = \text{MAX}, V_I = 2.4 \text{ V}$			40			40 $\mu\text{A}$
$I_{IL}$	Low-level input current	$V_{CC} = \text{MAX}, V_I = 0.4 \text{ V}$			-1 -1.6			-1 -1.6 mA
$I_{CCH}$	Supply current, outputs high	$V_{CC} = \text{MAX}, V_I = 5 \text{ V}$			7 11			7 11 mA
$I_{CCL}$	Supply current, outputs low	$V_{CC} = \text{MAX}, V_I = 0$			52 65			52 65 mA

† For conditions shown as MIN or MAX, use the appropriate value specified under recommended operating conditions.

‡ All typical values are at  $V_{CC} = 5 \text{ V}, T_A = 25^\circ\text{C}$ .

switching characteristics,  $V_{CC} = 5 \text{ V}, T_A = 25^\circ\text{C}$

PARAMETER	TEST CONDITIONS	MIN	TYP	MAX	UNIT
$t_{PLH}$	Propagation delay time, low-to-high-level output	18 25			ns
$t_{PHL}$	Propagation delay time, high-to-low-level output	18 25			ns
$t_{TLH}$	Transition time, low-to-high-level output	5 8			ns
$t_{THL}$	Transition time, high-to-low-level output	7 12			ns
$V_{OH}$	High-level output voltage after switching	$V_S = 20 \text{ V}, I_O \approx 300 \text{ mA}$ See Figure 4			$V_S - 6.5$ mV

TEXAS INSTRUMENTS  
INCORPORATED

POST OFFICE BOX 225012 • DALLAS, TEXAS 75265

# TYPES SN55452B, SN75452B

## DUAL PERIPHERAL POSITIVE-NAND DRIVERS

logic

FUNCTION TABLE  
(EACH DRIVER)

A	B	Y
L	L	H (off state)
L	H	H (off state)
H	L	H (off state)
H	H	L (on state)

H = high level, L = low level

SN55452B ... JG  
SN75452B ... JG OR P  
DUAL-IN-LINE PACKAGE (TOP VIEW)

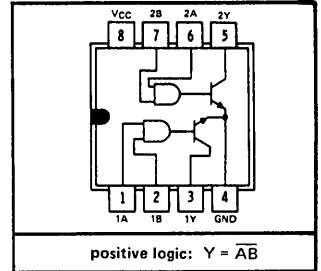

schematic (each driver)

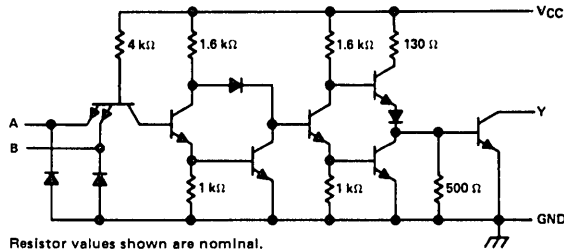

electrical characteristics over recommended operating free-air temperature range (unless otherwise noted)

PARAMETER	TEST CONDITIONS	SN55452B		SN75452B		UNIT		
		MIN	TYP <sup>†</sup>	MAX	MIN		TYP <sup>‡</sup>	MAX
$V_{IH}$	High-level input voltage	2			2		V	
$V_{IL}$	Low-level input voltage			0.8		0.8	V	
$V_{IK}$	Input clamp voltage			-1.2	-1.5	-1.2	-1.5	V
$I_{OH}$	High-level output current			300		100	$\mu$ A	
$V_{OL}$	Low-level output voltage	$V_{CC} = \text{MIN}, V_{IH} = 2 \text{ V}, I_{OL} = 100 \text{ mA}$	0.25	0.5	0.25	0.4	V	
		$V_{CC} = \text{MIN}, V_{IH} = 2 \text{ V}, I_{OL} = 300 \text{ mA}$	0.5	0.8	0.5	0.7		
$I_I$	Input current at maximum input voltage			1		1	mA	
$I_{IH}$	High-level input current			40		40	$\mu$ A	
$I_{IL}$	Low-level input current			-1.1	-1.6	-1.1	-1.6	mA
$I_{CCH}$	Supply current, outputs high			11	14	11	14	mA
$I_{CCL}$	Supply current, outputs low			56	71	56	71	mA

<sup>†</sup> For conditions shown as MIN or MAX, use the appropriate value specified under recommended operating conditions.

<sup>‡</sup> All typical values are at  $V_{CC} = 5 \text{ V}, T_A = 25^\circ \text{C}$ .

switching characteristics,  $V_{CC} = 5 \text{ V}, T_A = 25^\circ \text{C}$

PARAMETER	TEST CONDITIONS	MIN	TYP	MAX	UNIT
$t_{PLH}$	Propagation delay time, low-to-high-level output		26	35	ns
$t_{PHL}$	Propagation delay time, high-to-low-level output		24	35	ns
$t_{TLH}$	Transition time, low-to-high-level output		5	8	ns
$t_{THL}$	Transition time, high-to-low-level output		7	12	ns
$V_{OH}$	High-level output voltage after switching	$V_S = 20 \text{ V},$ See Figure 4	$I_O \approx 300 \text{ mA},$	$V_S - 6.5$	mV



# TYPES SN55453B, SN75453B DUAL PERIPHERAL POSITIVE-OR DRIVERS

logic

FUNCTION TABLE  
(EACH DRIVER)

A	B	Y
L	L	L (on state)
L	H	H (off state)
H	L	H (off state)
H	H	H (off state)

H = high level, L = low level

SN55453B . . . JG  
SN75453B . . . JG OR P  
DUAL-IN-LINE PACKAGE (TOP VIEW)

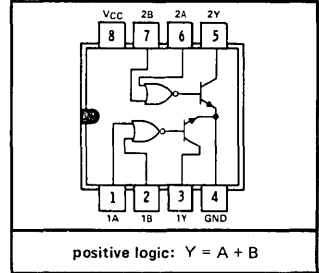

schematic (each driver)

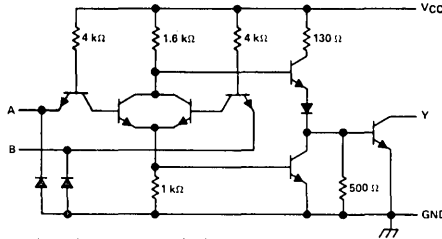

Resistor values shown are nominal.

electrical characteristics over recommended operating free-air temperature range (unless otherwise noted)

PARAMETER	TEST CONDITIONS†	SN55453B		SN75453B		UNIT		
		MIN	TYP‡	MAX	MIN		TYP‡	MAX
V <sub>IH</sub>	High-level input voltage	2			2		V	
V <sub>IL</sub>	Low-level input voltage			0.8		0.8	V	
V <sub>IK</sub>	Input clamp voltage	V <sub>CC</sub> = MIN, I <sub>I</sub> = -12 mA		-1.2	-1.5	-1.2	-1.5	V
I <sub>OH</sub>	High-level output current	V <sub>CC</sub> = MIN, V <sub>IH</sub> = 2 V, V <sub>OH</sub> = 30 V		300		100	μA	
V <sub>OL</sub>	Low-level output voltage	V <sub>CC</sub> = MIN, V <sub>IL</sub> = 0.8 V, I <sub>OL</sub> = 100 mA		0.25	0.5	0.25	0.4	V
		V <sub>CC</sub> = MIN, V <sub>IL</sub> = 0.8 V, I <sub>OL</sub> = 300 mA		0.5	0.8	0.5	0.7	
I <sub>I</sub>	Input current at maximum input voltage	V <sub>CC</sub> = MAX, V <sub>I</sub> = 5.5 V		1		1	mA	
I <sub>IH</sub>	High-level input current	V <sub>CC</sub> = MAX, V <sub>I</sub> = 2.4 V		40		40	μA	
I <sub>IL</sub>	Low-level input current	V <sub>CC</sub> = MAX, V <sub>I</sub> = 0.4 V		-1		-1.6	mA	
I <sub>CCH</sub>	Supply current, outputs high	V <sub>CC</sub> = MAX, V <sub>I</sub> = 5 V		8	11	8	11	mA
I <sub>CCL</sub>	Supply current, outputs low	V <sub>CC</sub> = MAX, V <sub>I</sub> = 0		54	68	54	68	mA

†For conditions shown as MIN or MAX, use the appropriate value specified under recommended operating conditions.

‡All typical values are at V<sub>CC</sub> = 5 V, T<sub>A</sub> = 25°C.

switching characteristics, V<sub>CC</sub> = 5 V, T<sub>A</sub> = 25°C

PARAMETER	TEST CONDITIONS	MIN	TYP	MAX	UNIT
t <sub>PLH</sub>	Propagation delay time, low-to-high-level output		18	25	ns
t <sub>PHL</sub>	Propagation delay time, high-to-low-level output		16	25	ns
t <sub>TLH</sub>	Transition time, low-to-high-level output	I <sub>O</sub> ≈ 200 mA, C <sub>L</sub> = 15 pF, R <sub>L</sub> = 50 Ω, See Figure 3	5	8	ns
t <sub>THL</sub>	Transition time, high-to-low-level output		7	12	ns
V <sub>OH</sub>	High-level output voltage after switching	V <sub>S</sub> = 20 V, See Figure 4	I <sub>O</sub> ≈ 300 mA,	V <sub>S</sub> -6.5	mV

TEXAS INSTRUMENTS  
INCORPORATED

POST OFFICE BOX 225012 • DALLAS, TEXAS 75265

# TYPES SN55454B, SN75454B

## DUAL PERIPHERAL POSITIVE-NOR DRIVERS

logic

FUNCTION TABLE  
(EACH DRIVER)

A	B	Y
L	L	H (off state)
L	H	L (on state)
H	L	L (on state)
H	H	L (on state)

H = high level, L = low level

SN55454B . . . JG  
SN75454B . . . JG OR P  
DUAL-IN-LINE PACKAGE (TOP VIEW)

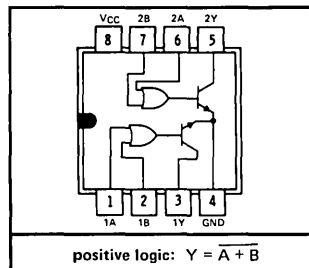

schematic (each driver)

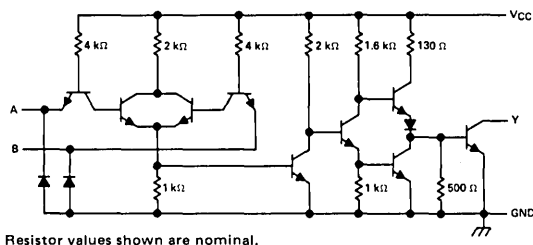

electrical characteristics over recommended operating free-air temperature range (unless otherwise noted)

PARAMETER	TEST CONDITIONS†	SN55454B		SN75454B		UNIT
		MIN	TYP‡	MAX	MIN	
$V_{IH}$ High-level input voltage		2			2	V
$V_{IL}$ Low-level input voltage				0.8		0.8
$V_{IK}$ Input clamp voltage	$V_{CC} = \text{MIN}, I_I = -12 \text{ mA}$	-1.2	-1.5	-1.2	-1.5	V
$I_{OH}$ High-level output current	$V_{CC} = \text{MIN}, V_{IL} = 0.8 \text{ V}, V_{OH} = 30 \text{ V}$		300		100	$\mu\text{A}$
$V_{OL}$ Low-level output voltage	$V_{CC} = \text{MIN}, V_{IH} = 2 \text{ V}, I_{OL} = 100 \text{ mA}$	0.25	0.5	0.25	0.4	V
	$V_{CC} = \text{MIN}, V_{IH} = 2 \text{ V}, I_{OL} = 300 \text{ mA}$	0.5	0.8	0.5	0.7	
$I_I$ Input current at maximum input voltage	$V_{CC} = \text{MAX}, V_I = 5.5 \text{ V}$		1		1	$\text{mA}$
$I_{IH}$ High-level input current	$V_{CC} = \text{MAX}, V_I = 2.4 \text{ V}$		40		40	$\mu\text{A}$
$I_{IL}$ Low-level input current	$V_{CC} = \text{MAX}, V_I = 0.4 \text{ V}$	-1	-1.6	-1	-1.6	$\text{mA}$
$I_{CCH}$ Supply current, outputs high	$V_{CC} = \text{MAX}, V_I = 0 \text{ V}$	13	17	13	17	$\text{mA}$
$I_{CCL}$ Supply current, outputs low	$V_{CC} = \text{MAX}, V_I = 5 \text{ V}$	61	79	61	79	$\text{mA}$

† For conditions shown as MIN or MAX, use the appropriate value specified under recommended operating conditions.

‡ All typical values are at  $V_{CC} = 5 \text{ V}, T_A = 25^\circ \text{C}$ .

switching characteristics,  $V_{CC} = 5 \text{ V}, T_A = 25^\circ \text{C}$

PARAMETER	TEST CONDITIONS	MIN	TYP	MAX	UNIT
$t_{PLH}$ Propagation delay time, low-to-high-level output	$I_O \approx 200 \text{ mA}, C_L = 15 \text{ pF}, R_L = 50 \Omega,$ See Figure 3		27	35	ns
$t_{PHL}$ Propagation delay time, high-to-low-level output			24	35	ns
$t_{TLH}$ Transition time, low-to-high-level output			5	8	ns
$t_{THL}$ Transition time, high-to-low-level output			7	12	ns
$V_{OH}$ High-level output voltage after switching	$V_S = 20 \text{ V},$ See Figure 4	$I_O \approx 300 \text{ mA},$		$V_S - 6.5$	$\text{mV}$

# SERIES 55450B/75450B DUAL PERIPHERAL DRIVERS

## PARAMETER MEASUREMENT INFORMATION

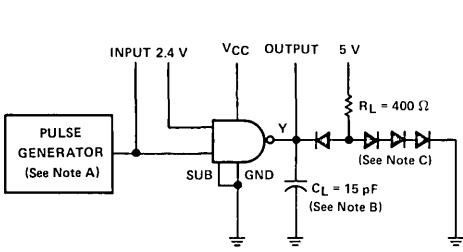

**TEST CIRCUIT**

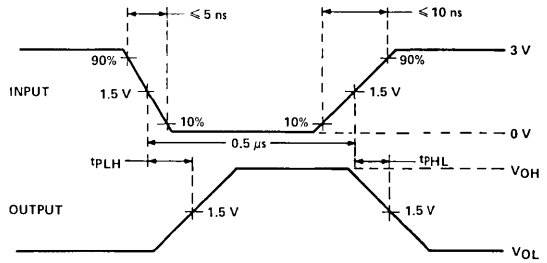

**VOLTAGE WAVEFORMS**

- NOTES: A. The pulse generator has the following characteristics: PRR = 1 MHz,  $Z_{out} \approx 50 \Omega$ .  
 B.  $C_L$  include probe and jig capacitance.  
 C. All diodes are 1N3064.

**FIGURE 1—PROPAGATION DELAY TIMES, EACH GATE (SN55450B and SN75450B ONLY)**

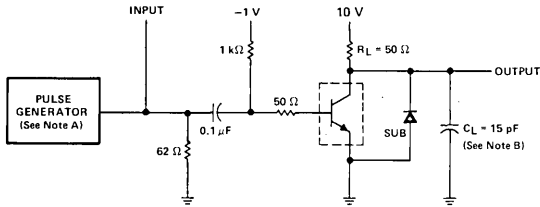

**TEST CIRCUIT**

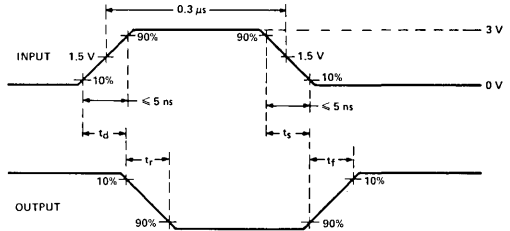

**VOLTAGE WAVEFORMS**

- NOTES: A. The pulse generator has the following characteristics: duty cycle  $\leq 1\%$ ,  $Z_{out} \approx 50 \Omega$ .  
 B.  $C_L$  includes probe and jig capacitance.

**FIGURE 2—SWITCHING TIMES, EACH TRANSISTOR (SN55450B AND SN75450B ONLY)**

# SERIES 55450B/75450B DUAL PERIPHERAL DRIVERS

## PARAMETER MEASUREMENT INFORMATION

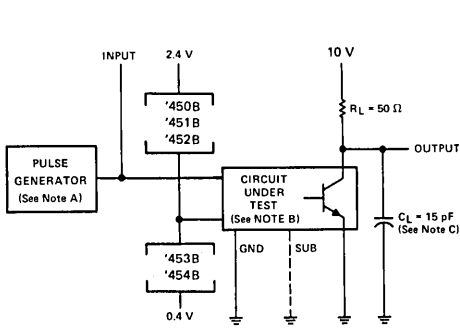

TEST CIRCUIT

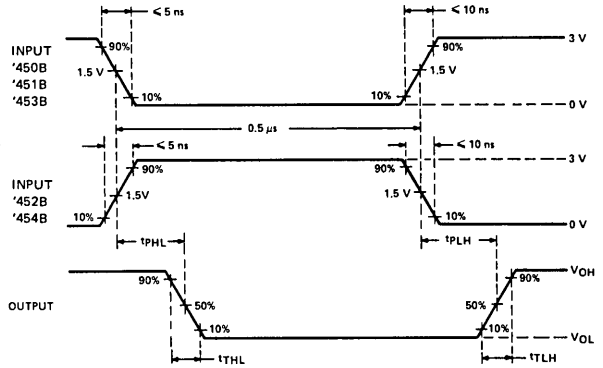

VOLTAGE WAVEFORMS

- NOTES: A. The pulse generator has the following characteristics: PRR = 1 MHz,  $Z_{out} \approx 50 \Omega$   
 B. When testing SN55450B or SN75450B, connect output Y to transistor base and ground the substrate terminal.  
 C.  $C_L$  includes probe and jig capacitance.

FIGURE 3—SWITCHING TIMES OF COMPLETE DRIVERS

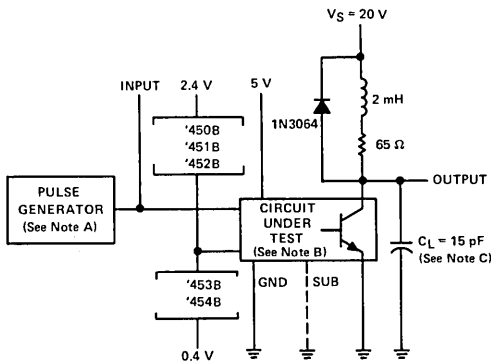

TEST CIRCUIT

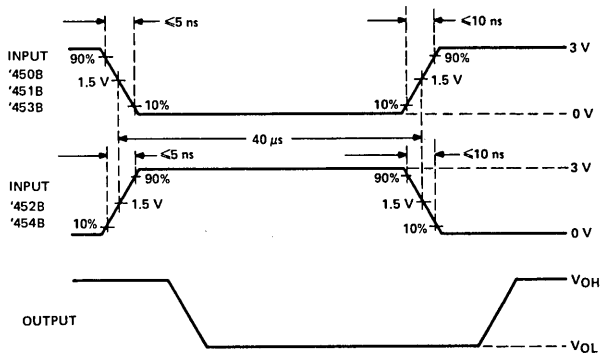

VOLTAGE WAVEFORMS

- NOTES: A. The pulse generator has the following characteristics: PRR = 12.5 kHz,  $Z_{out} = 50 \Omega$ .  
 B. When testing SN55450B or SN75450B, connect output Y to transistor base with a 500- $\Omega$  resistor from there to ground, and ground the substrate terminal.  
 C.  $C_L$  includes probe and jig capacitance.

FIGURE 4—LATCH-UP TEST OF COMPLETE DRIVERS

# SERIES 55450B/75450B DUAL PERIPHERAL DRIVERS

## TYPICAL CHARACTERISTICS

SN55450B, SN75450B  
TTL GATE  
HIGH-LEVEL OUTPUT VOLTAGE  
vs  
HIGH-LEVEL OUTPUT CURRENT

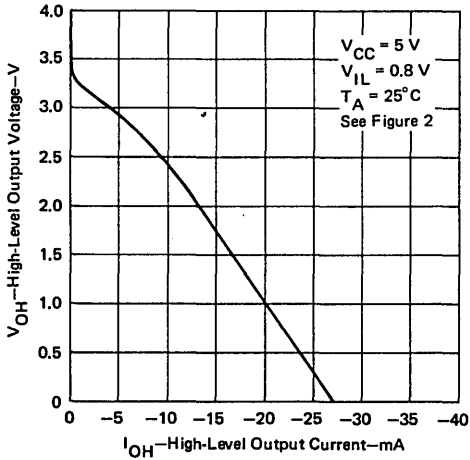

FIGURE 5

SN55450B, SN75450B  
TRANSISTOR  
STATIC FORWARD CURRENT TRANSFER RATIO  
vs  
COLLECTOR CURRENT

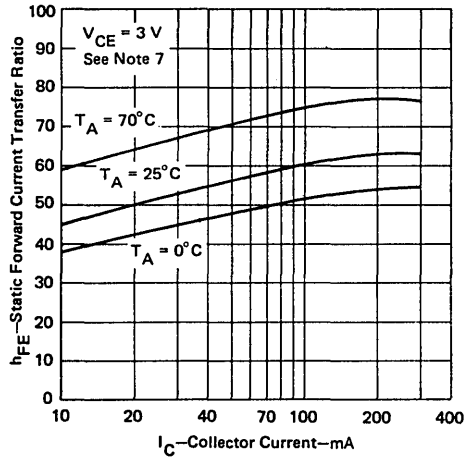

FIGURE 6

SN55450B, SN75450B  
TRANSISTOR  
BASE-EMITTER VOLTAGE  
vs  
COLLECTOR CURRENT

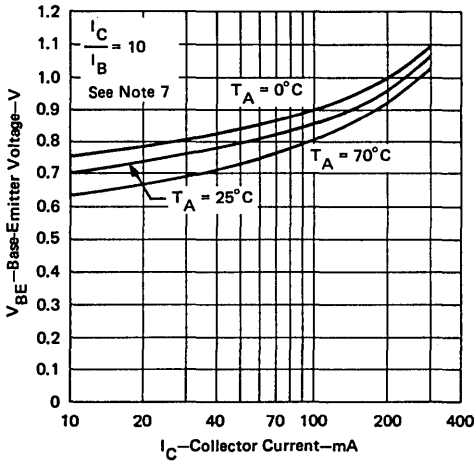

FIGURE 7

TRANSISTOR  
COLLECTOR-EMITTER SATURATION VOLTAGE  
vs  
COLLECTOR CURRENT

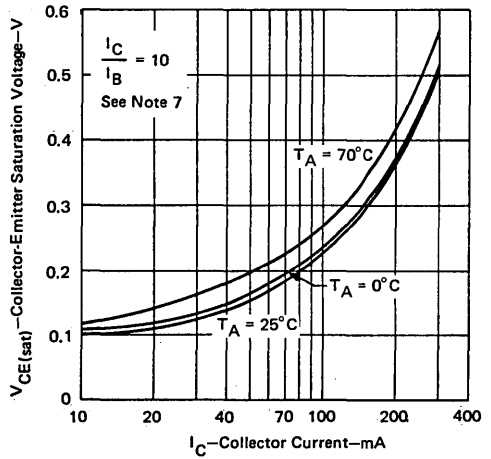

FIGURE 8

NOTE 7: These parameters must be measured using pulse techniques.  $t_w = 300 \mu s$ , duty cycle  $< 2\%$ .



**PERIPHERAL DRIVERS FOR  
HIGH-VOLTAGE, HIGH-CURRENT DRIVER APPLICATIONS**

**performance**

- Characterized for Use to 300 mA
- High-Voltage Outputs
- No Output Latch-Up at 30 V (After Conducting 300 mA)
- Medium-Speed Switching

**ease-of-design**

- Circuit Flexibility for Varied Applications and Choice of Logic Function
- TTL- or DTL-Compatible Diode-Clamped Inputs
- Standard Supply Voltages
- Available in Plastic and Ceramic Packages

SUMMARY OF SERIES 55460/75460

DEVICE	LOGIC OF COMPLETE CIRCUIT	PACKAGES
SN55460	AND <sup>†</sup>	J
SN55461	AND	JG
SN55462	NAND	JG
SN55463	OR	JG
SN55464	NOR	JG
SN75460	AND <sup>†</sup>	J, N
SN75461	AND	JG, P
SN75462	NAND	JG, P
SN75463	OR	JG, P
SN75464	NOR	JG, P

<sup>†</sup>With output transistor base connected externally to output of gate.

**description**

Series 55460/75460 dual peripheral drivers are functionally interchangeable with Series 55450B/75450B and Series 55460/75460 peripheral drivers, but are designed for use in systems that require higher breakdown voltages than either of those series can provide at the expense of slightly slower switching speeds. Typical applications include logic buffers, power drivers, relay drivers, lamp drivers, MOS drivers, line drivers, and memory drivers. Series 55460 drivers are characterized for operation over the full military temperature range of  $-55^{\circ}\text{C}$  to  $125^{\circ}\text{C}$ ; Series 75460 drivers are characterized for operation from  $0^{\circ}\text{C}$  to  $70^{\circ}\text{C}$ .

The SN55460 and SN75460 are unique general-purpose devices each featuring two standard Series 54/74 TTL gates and two uncommitted, high-current, high-voltage, n-p-n transistors. These devices offer the system designer the flexibility of tailoring the circuit to the application.

The SN55461/SN75461, SN55462/SN75462, SN55463/SN75463, and SN55464/SN75464 are dual peripheral AND, NAND, OR, and NOR drivers, respectively, (assuming positive logic) with the output of the gates internally connected to the bases of the n-p-n output transistors.

CONTENTS	PAGE
Maximum Ratings and Recommended Operating Conditions . . . . .	4-64
Definitive Specifications	
Types SN55460, SN75460 . . . . .	4-65
Types SN55461, SN75461 . . . . .	4-67
Types SN55462, SN75462 . . . . .	4-68
Types SN55463, SN75463 . . . . .	4-69
Types SN55464, SN75464 . . . . .	4-70
Switching Time Test Circuits and Voltage Waveforms . . . . .	4-71

# SERIES 55460/75460

## DUAL PERIPHERAL DRIVERS

absolute maximum ratings over operating free-air temperature range (unless otherwise noted)

	SN55460	SN55461 SN55462 SN55463 SN55464	SN75460	SN75461 SN75462 SN75463 SN75464	UNIT	
Supply voltage, $V_{CC}$ (see Note 1)	7	7	7	7	V	
Input voltage	5.5	5.5	5.5	5.5	V	
Interemitter voltage (see Note 2)	5.5	5.5	5.5	5.5	V	
$V_{CC}$ -to-substrate voltage	40		40		V	
Collector-to-substrate voltage	40		40		V	
Collector-base voltage	40		40		V	
Collector-emitter voltage (see Note 3)	40		40		V	
Collector-emitter voltage (see Note 4)	25		25		V	
Emitter-base voltage	5		5		V	
Off-state output voltage		35		35	V	
Continuous collector or output current (see Note 5)	400	400	400	400	mA	
Peak collector or output current ( $t_W < 10$ ms, duty cycle $< 50\%$ , see Note 5)	500	500	500	500	mA	
Continuous total dissipation at (or below) 25°C free-air temperature (see Note 6)	J package	1375	1025		mW	
	JG package		1050	825		
	N package		1150			
	P package			1000		
Operating free-air temperature range	-55 to 125	-55 to 125	0 to 70	0 to 70	°C	
Storage temperature range	-65 to 150	-65 to 150	-65 to 150	-65 to 150	°C	
Lead temperature 1/16 inch from case for 60 seconds	J or JG package		300	300	300	°C
Lead temperature 1/16 inch from case for 10 seconds	N or P package		260	260	260	°C

- NOTES: 1. Voltage values are with respect to network ground terminal unless otherwise specified.  
 2. This is the voltage between two emitters of a multiple-emitter transistor.  
 3. This value applies when the base-emitter resistance ( $R_{BE}$ ) is equal to or less than 500  $\Omega$ .  
 4. This value applies between 0 and 10 mA collector current when the base-emitter diode is open-circuited.  
 5. Both halves of these dual circuits may conduct rated current simultaneously; however, power dissipation averaged over a short time interval must fall within the continuous dissipation rating.  
 6. For operation above 25°C free-air temperature, refer to Dissipation Derating Curves in the Thermal Information Section, which starts on page 2-1. In the J and JG packages, SN55460 through SN55464 chips are alloy-mounted; SN75460 through SN75464 chips are glass-mounted.

recommended operating conditions (see Note 7)

	SERIES 55460			SERIES 75460			UNIT
	MIN	NOM	MAX	MIN	NOM	MAX	
Supply voltage, $V_{CC}$	4.5	5	5.5	4.75	5	5.25	V
Operating free-air temperature, $T_A$	-55		125	0		70	°C

NOTE 7: For SN55460 and SN75460 only, the substrate (pin 8) must always be at the most-negative device voltage for proper operation.



# TYPES SN55460, SN75460 DUAL PERIPHERAL POSITIVE-AND DRIVERS

## schematic

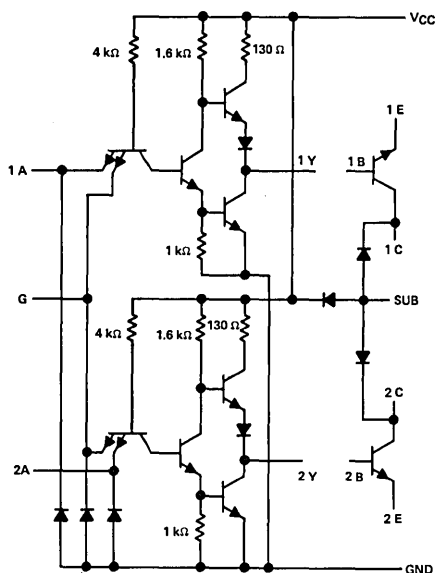

Resistor values shown are nominal.

SN55460 ... J  
SN75460 ... J OR N  
DUAL-IN-LINE PACKAGE (TOP VIEW)

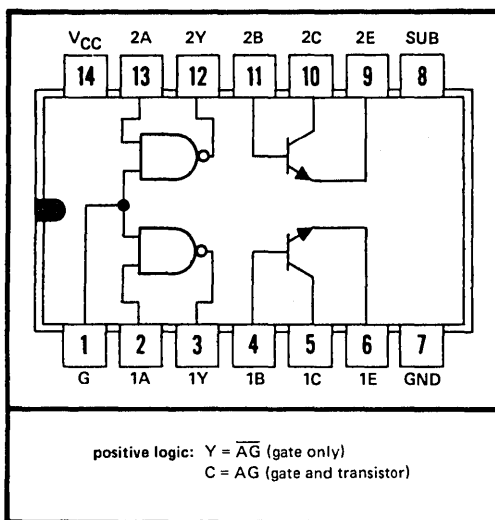

## electrical characteristics over recommended operating free-air temperature range (unless otherwise noted)

### TTL gates

PARAMETER	TEST CONDITIONS†	SN55460		SN75460		UNIT	
		MIN	TYP‡	MAX	MIN		TYP‡
$V_{IH}$ High-level input voltage		2			2	V	
$V_{IL}$ Low-level input voltage				0.8		0.8	
$V_{IK}$ Input clamp voltage	$V_{CC} = \text{MIN}, I_I = -12 \text{ mA}$	-1.2	-1.5	-1.2	-1.5	V	
$V_{OH}$ High-level output voltage	$V_{CC} = \text{MIN}, V_{IL} = 0.8 \text{ V}, I_{OH} = -400 \mu\text{A}$	2.4	3.3	2.4	3.3	V	
$V_{OL}$ Low-level output voltage	$V_{CC} = \text{MIN}, V_{IH} = 2 \text{ V}, I_{OL} = 16 \text{ mA}$	0.25	0.5	0.25	0.4	V	
$I_I$ Input current at maximum input voltage	input A		1		1	mA	
	input G		2		2		
$I_{IH}$ High-level input current	input A		40		40	$\mu\text{A}$	
	input G		80		80		
$I_{IL}$ Low-level input current	input A		-1.6		-1.6	mA	
	input G		-3.2		-3.2		
$I_{OS}$ Short-circuit output current §	$V_{CC} = \text{MAX}$	-18	-35	-55	-18	-35	-55
$I_{CCH}$ Supply current, outputs high	$V_{CC} = \text{MAX}, V_I = 0$		2.8	4		2.8	4
$I_{CCL}$ Supply current, outputs low	$V_{CC} = \text{MAX}, V_I = 5 \text{ V}$		7	11		7	11

† For conditions shown as MIN or MAX, use the appropriate value specified under recommended operating conditions.

‡ All typical values at  $V_{CC} = 5 \text{ V}, T_A = 25^\circ \text{C}$ .

§ Not more than one output should be shorted at a time.

# TYPES SN55460, SN75460

## DUAL PERIPHERAL POSITIVE-AND DRIVERS

electrical characteristics over recommended operating free-air temperature range (unless otherwise noted)

output transistors

PARAMETER	TEST CONDITIONS†	SN55460		SN75460		UNIT	
		MIN	TYP‡	MAX	MIN		TYP‡
V(BR)CBO	Collector-Base Breakdown Voltage Collector-Emitter Breakdown Voltage	I <sub>C</sub> = 100 μA, I <sub>E</sub> = 0		40		40	V
V(BR)CEO	Collector-Emitter Breakdown Voltage	I <sub>C</sub> = 10 mA, I <sub>B</sub> = 0, See Note 8		25		25	V
V(BR)CER	Collector-Emitter Breakdown Voltage	I <sub>C</sub> = 100 μA, R <sub>BE</sub> = 500 Ω		40		40	V
V(BR)EBO	Emitter-Base Breakdown Voltage	I <sub>E</sub> = 100 μA, I <sub>C</sub> = 0		5		5	V
h <sub>FE</sub>	Static Forward Current Transfer Ratio	See Note 8	V <sub>CE</sub> = 3 V, I <sub>C</sub> = 100 mA, T <sub>A</sub> = 25°C	25		25	
			V <sub>CE</sub> = 3 V, I <sub>C</sub> = 300 mA, T <sub>A</sub> = 25°C	30		30	
			V <sub>CE</sub> = 3 V, I <sub>C</sub> = 100 mA, T <sub>A</sub> = MIN	10		20	
			V <sub>CE</sub> = 3 V, I <sub>C</sub> = 300 mA, T <sub>A</sub> = MIN	15		25	
V <sub>BE</sub>	Base-Emitter Voltage	See Note 8	I <sub>B</sub> = 10 mA, I <sub>C</sub> = 100 mA	0.85	1.2	0.85	1
			I <sub>B</sub> = 30 mA, I <sub>C</sub> = 300 mA	1	1.4	1	1.2
V <sub>CE(sat)</sub>	Collector-Emitter Saturation Voltage	See Note 8	I <sub>B</sub> = 10 mA, I <sub>C</sub> = 100 mA	0.25	0.5	0.25	0.4
			I <sub>B</sub> = 30 mA, I <sub>C</sub> = 300 mA	0.45	0.8	0.45	0.7

†For conditions shown as MIN or MAX, use the appropriate value specified under recommended operating conditions.

‡All typical values are at V<sub>CC</sub> = 5 V, T<sub>A</sub> = 25°C.

NOTE 8: These parameters must be measured using pulse techniques. t<sub>w</sub> = 300 μs, duty cycle ≤ 2%.

switching characteristics, V<sub>CC</sub> = 5 V, T<sub>A</sub> = 25°C

TTL gates

PARAMETER	TEST CONDITIONS	MIN	TYP	MAX	UNIT
t <sub>PLH</sub>	Propagation delay time, low-to-high-level output		22		ns
t <sub>PHL</sub>	Propagation delay time, high-to-low-level output		8		ns

C<sub>L</sub> = 15 pF, R<sub>L</sub> = 400 Ω, See Figure 1

output transistors

PARAMETER	TEST CONDITIONS‡	MIN	TYP	MAX	UNIT
t <sub>d</sub>	I <sub>C</sub> = 200 mA, I <sub>B</sub> (1) = 20 mA, I <sub>B</sub> (2) = -40 mA, V <sub>BE(off)</sub> = -1 V, C <sub>L</sub> = 15 pF, R <sub>L</sub> = 50 Ω, See Figure 2		10		ns
t <sub>r</sub>			16		ns
t <sub>s</sub>			23		ns
t <sub>f</sub>			14		ns

‡Voltage and current values shown are nominal; exact values vary slightly with transistor parameters.

gates and transistors combined

PARAMETER	TEST CONDITIONS	MIN	TYP	MAX	UNIT
t <sub>PLH</sub>	I <sub>C</sub> ≈ 200 mA, C <sub>L</sub> = 15 pF, R <sub>L</sub> = 50 Ω, See Figure 3		45	65	ns
t <sub>PHL</sub>			35	50	ns
t <sub>TLH</sub>			10	20	ns
t <sub>THL</sub>			10	20	ns
V <sub>OH</sub>	V <sub>S</sub> = 30 V, I <sub>C</sub> ≈ 300 mA, R <sub>BE</sub> = 500 Ω, See Figure 4	V <sub>S</sub> -10			mV

# TYPES SN55461, SN75461 DUAL PERIPHERAL POSITIVE-AND DRIVERS

logic

FUNCTION TABLE  
(EACH DRIVER)

A	B	Y
L	L	L (on state)
L	H	L (on state)
H	L	L (on state)
H	H	H (off state)

H = high level, L = low level

schematic (each driver)

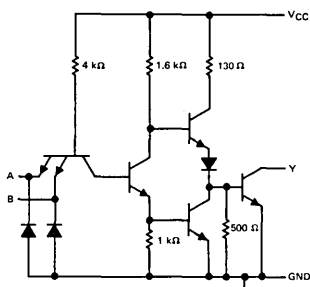

Resistor values shown are nominal.

SN55461 ... JG

SN75461 ... JG OR P

DUAL-IN-LINE PACKAGE (TOP VIEW)

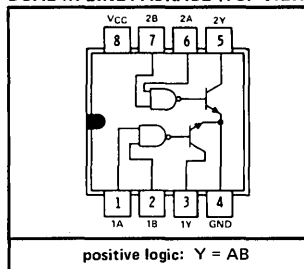

electrical characteristics over recommended operating free-air temperature range (unless otherwise noted)

PARAMETER	TEST CONDITIONS†	SN55461			SN75461			UNIT
		MIN	TYP‡	MAX	MIN	TYP‡	MAX	
V <sub>IH</sub>	High-level input voltage	2			2			V
V <sub>IL</sub>	Low-level input voltage				0.8			V
V <sub>IK</sub>	Input clamp voltage	V <sub>CC</sub> = MIN, I <sub>I</sub> = -12 mA		-1.2	-1.5	-1.2 -1.5		V
I <sub>OH</sub>	High-level output current	V <sub>CC</sub> = MIN, V <sub>IH</sub> = 2 V, V <sub>OH</sub> = 35 V		300		100		μA
V <sub>OL</sub>	Low-level output voltage	V <sub>CC</sub> = MIN, V <sub>IL</sub> = 0.8 V, I <sub>OL</sub> = 100 mA		0.25	0.5	0.25	0.4	V
		V <sub>CC</sub> = MIN, V <sub>IL</sub> = 0.8 V, I <sub>OL</sub> = 300 mA		0.5	0.8	0.5	0.7	
I <sub>I</sub>	Input current at maximum input voltage	V <sub>CC</sub> = MAX, V <sub>I</sub> = 5.5 V		1			1	mA
I <sub>IH</sub>	High-level input current	V <sub>CC</sub> = MAX, V <sub>I</sub> = 2.4 V		40			40	μA
I <sub>IL</sub>	Low-level input current	V <sub>CC</sub> = MAX, V <sub>I</sub> = 0.4 V		-1	-1.6	-1	-1.6	mA
I <sub>CCH</sub>	Supply current, outputs high	V <sub>CC</sub> = MAX, V <sub>I</sub> = 5 V		8	11	8	11	mA
I <sub>CCL</sub>	Supply current, outputs low	V <sub>CC</sub> = MAX, V <sub>I</sub> = 0		56	76	56	76	mA

† For conditions shown as MIN or MAX, use the appropriate value specified under recommended operating conditions.

‡ All typical values are at V<sub>CC</sub> = 5 V, T<sub>A</sub> = 25°C.

switching characteristics, V<sub>CC</sub> = 5 V, T<sub>A</sub> = 25°C

PARAMETER	TEST CONDITIONS	MIN	TYP	MAX	UNIT
t <sub>PLH</sub>	Propagation delay time, low-to-high-level output	30		55	ns
t <sub>PHL</sub>	Propagation delay time, high-to-low-level output	25		40	ns
t <sub>TLH</sub>	Transition time, low-to-high-level output	8		20	ns
t <sub>THL</sub>	Transition time, high-to-low-level output	10		20	ns
V <sub>OH</sub>	High-level output voltage after switching	V <sub>S</sub> = 30 V, I <sub>O</sub> ≈ 300 mA, See Figure 4		V <sub>S</sub> - 10	mV

TEXAS INSTRUMENTS  
INCORPORATED

POST OFFICE BOX 225012 • DALLAS, TEXAS 75265

# TYPES SN55462, SN75462 DUAL PERIPHERAL POSITIVE-NAND DRIVERS

logic

FUNCTION TABLE  
(EACH DRIVER)

A	B	Y
L	L	H (off state)
L	H	H (off state)
H	L	H (off state)
H	H	L (on state)

H = high level, L = low level

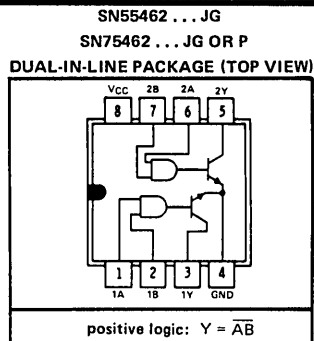

schematic (each driver)

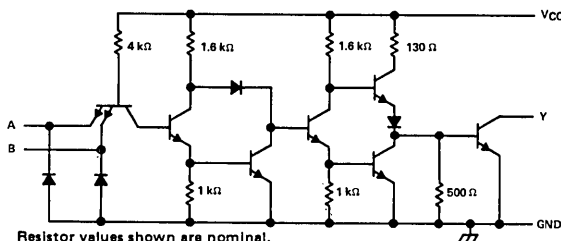

electrical characteristics over recommended operating free-air temperature range (unless otherwise noted)

PARAMETER	TEST CONDITIONS	SN55462		SN75462		UNIT
		MIN	TYP <sup>†</sup> MAX	MIN	TYP <sup>‡</sup> MAX	
$V_{IH}$	High-level input voltage	2		2		V
$V_{IL}$	Low-level input voltage		0.8		0.8	V
$V_{IK}$	Input clamp voltage		-1.2 -1.5		-1.2 -1.5	V
$I_{OH}$	High-level output current	$V_{CC} = \text{MIN}, I_I = -12 \text{ mA}$		300	100	$\mu\text{A}$
$V_{OL}$	Low-level output voltage	$V_{CC} = \text{MIN}, V_{IH} = 2 \text{ V}, I_{OL} = 100 \text{ mA}$	0.25 0.5	0.25	0.4	V
		$V_{CC} = \text{MIN}, V_{IH} = 2 \text{ V}, I_{OL} = 300 \text{ mA}$	0.5 0.8	0.5	0.7	
$I_I$	Input current at maximum input voltage	$V_{CC} = \text{MAX}, V_I = 5.5 \text{ V}$		1		1 mA
$I_{IH}$	High-level input current	$V_{CC} = \text{MAX}, V_I = 2.4 \text{ V}$		40		40 $\mu\text{A}$
$I_{IL}$	Low-level input current	$V_{CC} = \text{MAX}, V_I = 0.4 \text{ V}$	-1.1 -1.6		-1.1 -1.6	mA
$I_{CCH}$	Supply current, outputs high	$V_{CC} = \text{MAX}, V_I = 0 \text{ V}$	13 17		13 17	mA
$I_{CCL}$	Supply current, outputs low	$V_{CC} = \text{MAX}, V_I = 5 \text{ V}$	61 76		61 76	mA

<sup>†</sup>For conditions shown as MIN or MAX, use the appropriate value specified under recommended operating conditions.

<sup>‡</sup>All typical values are at  $V_{CC} = 5 \text{ V}, T_A = 25^\circ\text{C}$ .

switching characteristics,  $V_{CC} = 5 \text{ V}, T_A = 25^\circ\text{C}$

PARAMETER	TEST CONDITIONS	MIN	TYP	MAX	UNIT
$t_{pLH}$	Propagation delay time, low-to-high-level output		45	65	ns
$t_{pHL}$	Propagation delay time, high-to-low-level output		30	50	ns
$t_{TLH}$	Transition time, low-to-high-level output		13	25	ns
$t_{THL}$	Transition time, high-to-low-level output		10	20	ns
$V_{OH}$	High-level output voltage after switching	$V_S = 30 \text{ V}, I_O \approx 300 \text{ mA},$ See Figure 4	$V_S - 10$		mV

# TYPES SN55463, SN75463 DUAL PERIPHERAL POSITIVE-OR DRIVERS

logic

FUNCTION TABLE  
(EACH DRIVER)

A	B	Y
L	L	L (on state)
L	H	H (off state)
H	L	H (off state)
H	H	H (off state)

H = high level, L = low level

SN55463 ... JG  
SN75463 ... JG OR P  
DUAL-IN-LINE PACKAGE (TOP VIEW)

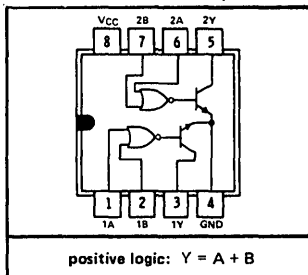

schematic (each driver)

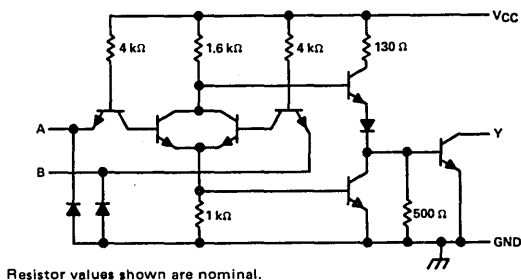

electrical characteristics over recommended operating free-air temperature range (unless otherwise noted)

PARAMETER	TEST CONDITIONS†	SN55463		SN75463		UNIT		
		MIN	TYP‡	MAX	MIN		TYP‡	MAX
$V_{IH}$	High-level input voltage	2			2		V	
$V_{IL}$	Low-level input voltage			0.8		0.8	V	
$V_{IK}$	Input clamp voltage			-1.2	-1.5	-1.2	-1.5	V
$I_{OH}$	High-level output current	$V_{CC} = \text{MIN}, I_I = -12 \text{ mA}$		300		100	$\mu\text{A}$	
$V_{OL}$	Low-level output voltage	$V_{CC} = \text{MIN}, V_{IH} = 2 \text{ V}, V_{OH} = 35 \text{ V}$						
		$V_{CC} = \text{MIN}, V_{IL} = 0.8 \text{ V}, I_{OL} = 100 \text{ mA}$		0.25	0.5	0.25	0.4	V
		$V_{CC} = \text{MIN}, V_{IL} = 0.8 \text{ V}, I_{OL} = 300 \text{ mA}$		0.5	0.8	0.5	0.7	V
$I_I$	Input current at maximum input voltage	$V_{CC} = \text{MAX}, V_I = 5.5 \text{ V}$		1		1	mA	
$I_{IH}$	High-level input current	$V_{CC} = \text{MAX}, V_I = 2.4 \text{ V}$		40		40	$\mu\text{A}$	
$I_{IL}$	Low-level input current	$V_{CC} = \text{MAX}, V_I = 0.4 \text{ V}$		-1	-1.6	-1	-1.6	mA
$I_{CCH}$	Supply current, outputs high	$V_{CC} = \text{MAX}, V_I = 5 \text{ V}$		8	11	8	11	mA
$I_{CCL}$	Supply current, outputs low	$V_{CC} = \text{MAX}, V_I = 0$		58	76	58	76	mA

†For conditions shown as MIN or MAX, use the appropriate value specified under recommended operating conditions.

‡All typical values are at  $V_{CC} = 5 \text{ V}, T_A = 25^\circ\text{C}$ .

switching characteristics,  $V_{CC} = 5 \text{ V}, T_A = 25^\circ\text{C}$

PARAMETER	TEST CONDITIONS	MIN	TYP	MAX	UNIT	
$t_{PLH}$	Propagation delay time, low-to-high-level output		30	55	ns	
$t_{PHL}$	Propagation delay time, high-to-low-level output		25	40	ns	
$t_{TLH}$	Transition time, low-to-high-level output	$I_O \approx 200 \text{ mA}, C_L = 15 \text{ pF}, R_L = 50 \Omega,$		8	25	ns
$t_{THL}$	Transition time, high-to-low-level output	See Figure 3		10	25	ns
$V_{OH}$	High-level output voltage after switching	$V_S = 30 \text{ V}, I_O \approx 300 \text{ mA},$		$V_S - 10$	mV	
		See Figure 4				

TEXAS INSTRUMENTS  
INCORPORATED

POST OFFICE BOX 225012 • DALLAS, TEXAS 75285

# TYPES SN55464, SN75464

## DUAL PERIPHERAL POSITIVE-NOR DRIVERS

logic

FUNCTION TABLE  
(EACH DRIVER)

A	B	Y
L	L	H (off state)
L	H	L (on state)
H	L	L (on state)
H	H	L (on state)

H = high level, L = low level

SN55464 . . . JG  
SN75464 . . . JG OR P  
DUAL-IN-LINE PACKAGE (TOP VIEW)

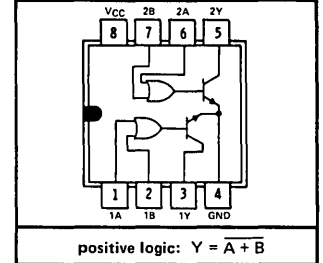

schematic (each driver)

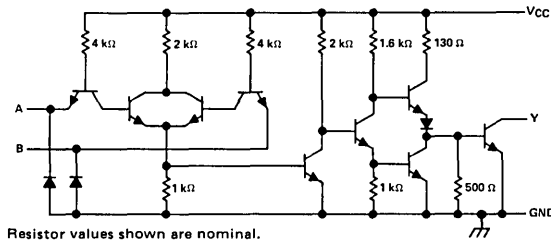

electrical characteristics over recommended operating free-air temperature range (unless otherwise noted)

PARAMETER	TEST CONDITIONS†	SN55464		SN75464		UNIT
		MIN	TYP‡	MAX	MIN	
$V_{IH}$ High-level input voltage		2			2	V
$V_{IL}$ Low-level input voltage				0.8		0.8
$V_{IK}$ Input clamp voltage	$V_{CC} = \text{MIN}, I_I = -12 \text{ mA}$	-1.2	-1.5	-1.2	-1.5	V
$I_{OH}$ High-level output current	$V_{CC} = \text{MIN}, V_{IH} = 0.8 \text{ V}, V_{OH} = 25 \text{ V}$		300		100	$\mu\text{A}$
$V_{OL}$ Low-level output voltage	$V_{CC} = \text{MIN}, V_{IH} = 2 \text{ V}, I_{OL} = 100 \text{ mA}$	0.25	0.5	0.25	0.4	V
	$V_{CC} = \text{MIN}, V_{IH} = 2 \text{ V}, I_{OL} = 300 \text{ mA}$	0.5	0.8	0.5	0.7	
$I_I$ Input current at maximum input voltage	$V_{CC} = \text{MAX}, V_I = 5.5 \text{ V}$		1		1	$\text{mA}$
$I_{IH}$ High-level input current	$V_{CC} = \text{MAX}, V_I = 2.4 \text{ V}$		40		40	$\mu\text{A}$
$I_{IL}$ Low-level input current	$V_{CC} = \text{MAX}, V_I = 0.4 \text{ V}$	-1	-1.6	-1	-1.6	$\text{mA}$
$I_{CCH}$ Supply current, outputs high	$V_{CC} = \text{MAX}, V_I = 0 \text{ V}$	14	19	14	19	$\text{mA}$
$I_{CCL}$ Supply current, outputs low	$V_{CC} = \text{MAX}, V_I = 5 \text{ V}$	67	85	67	85	$\text{mA}$

†For conditions shown as MIN or MAX, use the appropriate value specified under recommended operating conditions.  
‡All typical values are at  $V_{CC} = 5 \text{ V}, T_A = 25^\circ \text{C}$ .

switching characteristics,  $V_{CC} = 5 \text{ V}, T_A = 25^\circ \text{C}$

PARAMETER	TEST CONDITIONS	MIN	TYP	MAX	UNIT	
$t_{PLH}$ Propagation delay time, low-to-high-level output	$I_O \approx 200 \text{ mA}, C_L = 15 \text{ pF}, R_L = 50 \Omega,$ See Figure 3		40	65	ns	
$t_{PHL}$ Propagation delay time, high-to-low-level output			30	50	ns	
$t_{TLH}$ Transition time, low-to-high-level output				8	20	ns
$t_{THL}$ Transition time, high-to-low-level output				10	20	ns
$V_{OH}$ High-level output voltage after switching	$V_S = 30 \text{ V},$ See Figure 4		$I_O \approx 300 \text{ mA},$	$V_S - 10$	mV	

# SERIES 55460/75460 DUAL PERIPHERAL DRIVERS

## PARAMETER MEASUREMENT INFORMATION

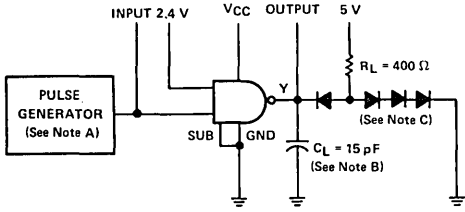

**TEST CIRCUIT**

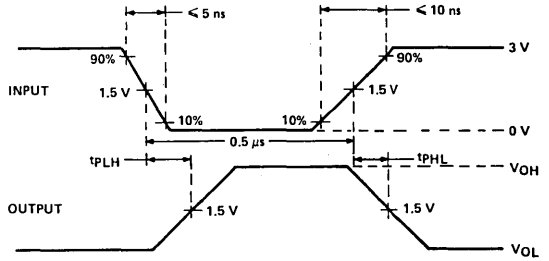

**VOLTAGE WAVEFORMS**

- NOTES: A. The pulse generator has the following characteristics: PRR = 1 MHz,  $Z_{out} \approx 50 \Omega$ .  
 B.  $C_L$  include probe and jig capacitance.  
 C. All diodes are 1N3064.

**FIGURE 1—PROPAGATION DELAY TIMES, EACH GATE (SN55460 AND SN75460 ONLY)**

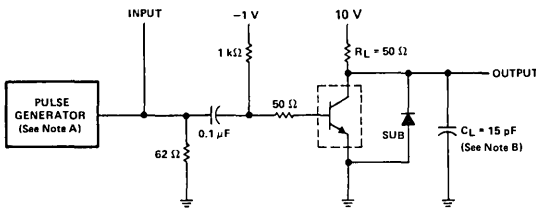

**TEST CIRCUIT**

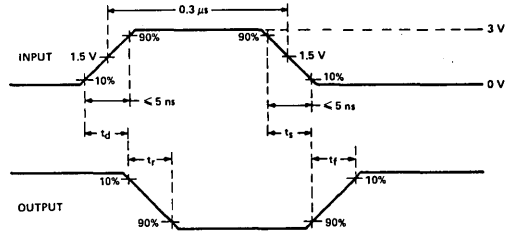

**VOLTAGE WAVEFORMS**

- NOTES: A. The pulse generator has the following characteristics: duty cycle  $\leq 1\%$ ,  $Z_{out} \approx 50 \Omega$ .  
 B.  $C_L$  includes probe and jig capacitance.

**FIGURE 2—SWITCHING TIMES, EACH TRANSISTOR (SN55460 AND SN75460 ONLY)**

# SERIES 55460/75460 DUAL PERIPHERAL DRIVERS

## PARAMETER MEASUREMENT INFORMATION

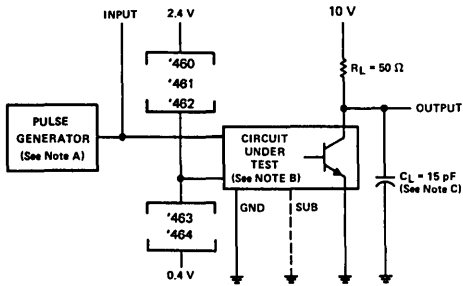

TEST CIRCUIT

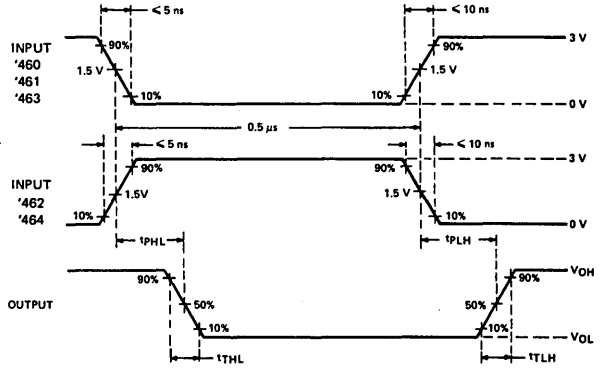

VOLTAGE WAVEFORMS

- NOTES: A. The pulse generator has the following characteristics: PRR = 1 MHz,  $Z_{out} \approx 50 \Omega$   
 B. When testing SN55460 or SN75460, connect output Y to transistor-base and ground the substrate terminal.  
 C.  $C_L$  includes probe and jig capacitance.

FIGURE 3—SWITCHING TIMES OF COMPLETE DRIVERS

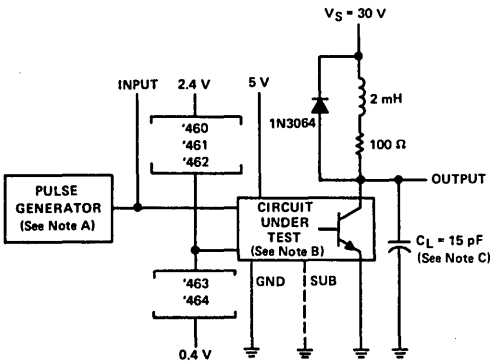

TEST CIRCUIT

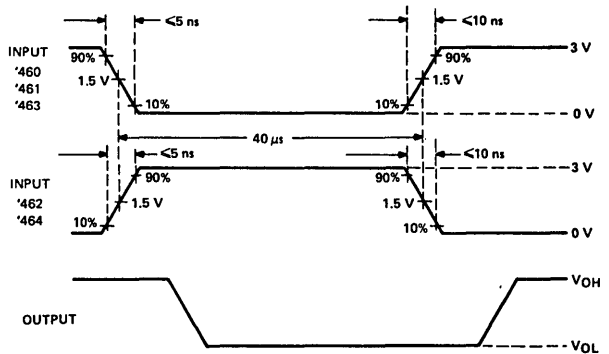

VOLTAGE WAVEFORMS

- NOTES: A. The pulse generator has the following characteristics: PRR = 12.5 kHz,  $Z_{out} = 50 \Omega$ .  
 B. When testing SN55460 or SN75460, connect output Y to transistor base with a 500- $\Omega$  resistor from there to ground, and ground the substrate terminal.  
 C.  $C_L$  includes probe and jig capacitance.

FIGURE 4—LATCH-UP TEST OF COMPLETE DRIVERS



**HIGH-VOLTAGE HIGH-CURRENT DARLINGTON TRANSISTOR ARRAYS**

- 500 mA Rated Collector Current (Single Output)
- High-Voltage Outputs . . . 100 V
- Output Clamp Diodes
- Inputs Compatible with Various Types of Logic
- Relay Driver Applications
- Higher-Voltage Versions of ULN2005A, ULN2001A, ULN2002A, ULN2003A, and ULN2004A, Respectively

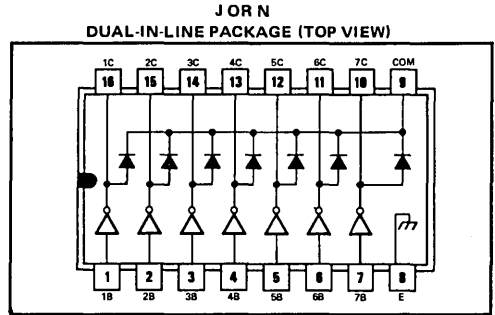

**description**

Series 75465 devices are monolithic high-voltage, high-current darlington transistor arrays. Each comprises seven n-p-n darlington pairs. All units feature high-voltage outputs with common-cathode clamp diodes for switching inductive loads. The collector-current rating of a single darlington pair is 500 milliamperes. Outputs and inputs may each be paralleled for higher current capability. Applications include relay drivers, hammer drivers, lamp drivers, display drivers (LED and gas discharge), line drivers, and logic buffers.

The SN75465 has a 1.05-k $\Omega$  series base resistor and is especially designed for use with TTL where higher output current is required and loading of the driving source is not a concern. The SN75466 is a general-purpose array and may be used with DTL, TTL, P-MOS, CMOS, etc. The SN75467 is specifically designed for use with 14- to 25-volt P-MOS devices and each input has a zener diode and resistor in series to limit the input current to a safe limit. The SN75468 has a 2.7-k $\Omega$  series base resistor to each darlington pair. This allows operation directly with TTL or 5-volt CMOS. The SN75469 has an appropriate series input resistor to allow its operation directly from CMOS or P-MOS utilizing supply voltages of 6 to 15 volts. The required input current is below that of the SN75468 while the required voltage is less than that required by the SN75467.

**schematics (each darlington pair)**

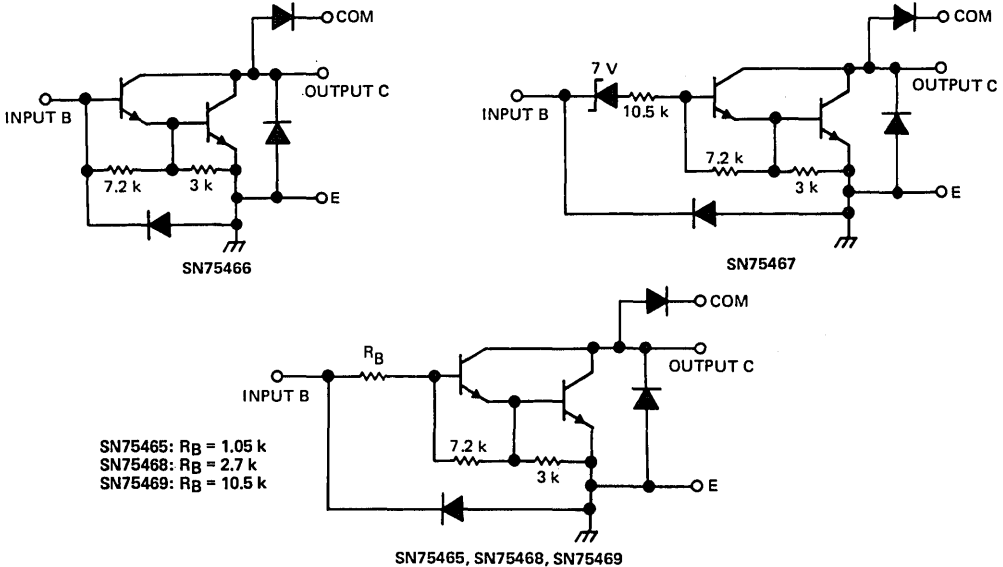

All resistor values shown are nominal and in ohms.

Copyright © 1980 by Texas Instruments Incorporated

# SERIES 75465

## DARLINGTON TRANSISTOR ARRAYS

absolute maximum ratings at 25°C free-air temperature (unless otherwise noted)

Collector-emitter voltage	100 V
Input voltage (see Note 1): SN75465	15 V
SN75467, SN75468, SN75469	30 V
Peak collector current (see Figures 14 and 15)	500 mA
Output clamp diode current	500 mA
Continuous input current, SN75466 only	25 mA
Total substrate-terminal current: J package	-500 mA
N package	-2.5 A
Continuous dissipation (total package) at (or below) 25°C free-air temperature (see Note 2):	
J package	1025 mW
N package	1150 mW
Operating free-air temperature range	0°C to 70°C
Storage temperature range	-65°C to 150°C
Lead temperature 1/16 inch from case for 60 seconds, J package	300°C
Lead temperature 1/16 inch from case for 10 seconds, N package	260°C

- NOTES: 1. All voltage values, unless otherwise noted, are with respect to the emitter/substrate terminal, E.  
 2. For operation above 25°C free-air temperature, refer to the Dissipation Derating Curves in the Thermal Information section, which starts on page 2-1. In the J package, SN75465 through SN75469 chips are glass-mounted.

electrical characteristics at 25°C free-air temperature (unless otherwise noted)

PARAMETER	TEST FIGURE	TEST CONDITIONS	SN75465			UNIT
			MIN	TYP	MAX	
I <sub>CEX</sub> Collector cutoff current	1	V <sub>CE</sub> = 100 V, I <sub>I</sub> = 0			50	μA
		V <sub>CE</sub> = 100 V, I <sub>I</sub> = 0, T <sub>A</sub> = 70°C			100	
I <sub>I(off)</sub> Off-state input current	3	V <sub>CE</sub> = 100 V, I <sub>C</sub> = 500 μA, T <sub>A</sub> = 70°C	50	65		μA
I <sub>I</sub> Input current	4	V <sub>I</sub> = 3 V		1.5	2.4	mA
V <sub>I(on)</sub> On-state input voltage	5	V <sub>CE</sub> = 2 V, I <sub>C</sub> = 350 mA			2.4	V
V <sub>CE(sat)</sub> Collector-emitter saturation voltage	6	I <sub>I</sub> = 250 μA, I <sub>C</sub> = 100 mA		0.9	1.1	V
		I <sub>I</sub> = 350 μA, I <sub>C</sub> = 200 mA		1.0	1.3	
		I <sub>I</sub> = 500 μA, I <sub>C</sub> = 350 mA		1.2	1.6	
I <sub>R</sub> Clamp diode reverse current	7	V <sub>R</sub> = 100 V			50	μA
		V <sub>R</sub> = 100 V, T <sub>A</sub> = 70°C			100	
V <sub>F</sub> Clamp diode forward voltage	8	I <sub>F</sub> = 350 mA		1.7	2	V
C <sub>i</sub> Input capacitance		V <sub>I</sub> = 0 V, f = 1 MHz		15	25	pF

# SERIES 75465 DARLINGTON TRANSISTOR ARRAYS

electrical characteristics at 25°C free-air temperature (unless otherwise noted)

PARAMETER	TEST FIGURE	TEST CONDITIONS	SN75466			SN75467			UNIT
			MIN	TYP	MAX	MIN	TYP	MAX	
$I_{CEX}$ Collector cutoff current	1	$V_{CE} = 100\text{ V}, I_I = 0$	50			50			$\mu\text{A}$
	2	$V_{CE} = 100\text{ V}, I_I = 0$ $T_A = 70^\circ\text{C}$ $V_I = 6\text{ V}$	100			100			
$I_{I(off)}$ Off-state input current	3	$V_{CE} = 50\text{ V}, I_C = 500\ \mu\text{A}, T_A = 70^\circ\text{C}$	50	65		50	65	$\mu\text{A}$	
$I_I$ Input current	4	$V_I = 17\text{ V}$				0.85	1.3	$\text{mA}$	
$h_{FE}$ Static forward current transfer ratio	6	$V_{CE} = 2\text{ V}, I_C = 350\text{ mA}$	1000						
$V_{I(on)}$ On-state input voltage	5	$V_{CE} = 2\text{ V}, I_C = 300\text{ mA}$					13	$\text{V}$	
$V_{CE(sat)}$ Collector-emitter saturation voltage	6	$I_I = 250\ \mu\text{A}, I_C = 100\text{ mA}$	0.9	1.1		0.9	1.1	$\text{V}$	
		$I_I = 350\ \mu\text{A}, I_C = 200\text{ mA}$	1.0	1.3		1.0	1.3		
		$I_I = 500\ \mu\text{A}, I_C = 350\text{ mA}$	1.2	1.6		1.2	1.6		
$I_R$ Clamp diode reverse current	7	$V_R = 100\text{ V}, T_A = 70^\circ\text{C}$	50			50			$\mu\text{A}$
		$V_R = 100\text{ V}, T_A = 70^\circ\text{C}$	100			100			
$V_F$ Clamp diode forward voltage	8	$I_F = 350\text{ mA}$	1.7	2		1.7	2	$\text{V}$	
$C_i$ Input capacitance		$V_I = 0\text{ V}, f = 1\text{ MHz}$	15	25		15	25	$\text{pF}$	

electrical characteristics at 25°C free-air temperature (unless otherwise noted)

PARAMETER	TEST FIGURE	TEST CONDITIONS	SN75468			SN75469			UNIT
			MIN	TYP	MAX	MIN	TYP	MAX	
$I_{CEX}$ Collector cutoff current	1	$V_{CE} = 100\text{ V}, I_I = 0$	50			50			$\mu\text{A}$
	2	$V_{CE} = 100\text{ V}, I_I = 0$ $T_A = 70^\circ\text{C}$ $V_I = 1\text{ V}$	100			100			
$I_{I(off)}$ Off-state input current	3	$V_{CE} = 50\text{ V}, I_C = 500\ \mu\text{A}, T_A = 70^\circ\text{C}$	50	65		50	65	$\mu\text{A}$	
$I_I$ Input current	4	$V_I = 3.85\text{ V}$	0.93	1.35				$\text{mA}$	
		$V_I = 5\text{ V}$				0.35	0.5		
		$V_I = 12\text{ V}$				1.0	1.45		
$V_{I(on)}$ On-state input voltage	5	$V_{CE} = 2\text{ V}$	$I_C = 125\text{ mA}$					5	$\text{V}$
			$I_C = 200\text{ mA}$			2.4		6	
			$I_C = 250\text{ mA}$			2.7			
			$I_C = 275\text{ mA}$					7	
			$I_C = 300\text{ mA}$			3			
			$I_C = 350\text{ mA}$					8	
$V_{CE(sat)}$ Collector-emitter saturation voltage	6	$I_I = 250\ \mu\text{A}, I_C = 100\text{ mA}$	0.9	1.1		0.9	1.1		
		$I_I = 350\ \mu\text{A}, I_C = 200\text{ mA}$	1.0	1.3		1.0	1.3		
		$I_I = 500\ \mu\text{A}, I_C = 350\text{ mA}$	1.2	1.6		1.2	1.6		
$I_R$ Clamp diode reverse current	7	$V_R = 100\text{ V}$	50			50			$\mu\text{A}$
		$V_R = 100\text{ V}, T_A = 70^\circ\text{C}$	100			100			
$V_F$ Clamp diode forward voltage	8	$I_F = 305\text{ mA}$	1.7	2		1.7	2	$\text{V}$	
$C_i$ Input capacitance		$V_I = 0\text{ V}, f = 1\text{ MHz}$	15	25		15	25	$\text{pF}$	

switching characteristics at 25°C free-air temperature

PARAMETER	TEST CONDITIONS	MIN	TYP	MAX	UNIT
$t_{PLH}$ Propagation delay time, low-to-high-level output	$V_S = 50\text{ V}, R_L = 163\ \Omega,$		130		$\text{ns}$
$t_{PHL}$ Propagation delay time, high-to-low-level output	$C_L = 15\ \text{pF},$ See Figure 9		20		$\text{ns}$
$V_{OH}$ High-level output voltage after switching	$V_S = 60\text{ V}, I_O \approx 300\text{ mA},$ See Figure 10	$V_S - 20$			$\text{mV}$

TEXAS INSTRUMENTS  
INCORPORATED

POST OFFICE BOX 225012 • DALLAS, TEXAS 75265

**SERIES 75465  
DARLINGTON TRANSISTOR ARRAYS**

**PARAMETER MEASUREMENT INFORMATION**

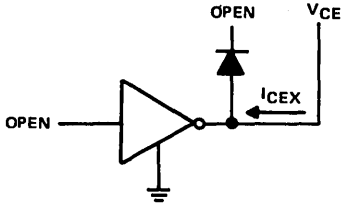

FIGURE 1- $I_{CEX}$

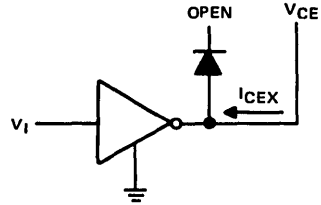

FIGURE 2- $I_{CEX}$

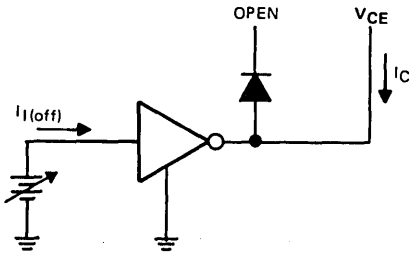

FIGURE 3- $I_{I(off)}$

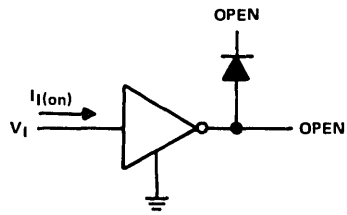

FIGURE 4- $I_I$

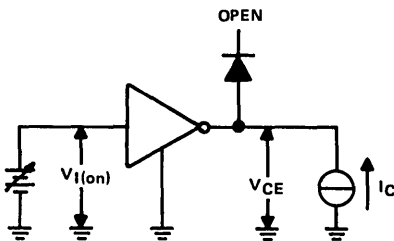
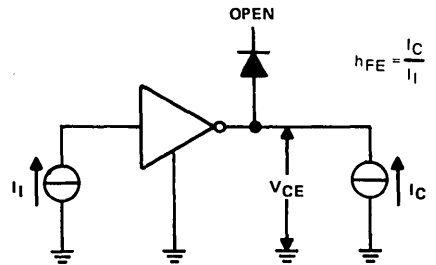

FIGURE 5- $V_{I(on)}$



NOTE:  $I_I$  is fixed for measuring  $V_{CE(sat)}$ , variable for measuring  $h_{FE}$ .

FIGURE 6- $h_{FE}$ ,  $V_{CE(sat)}$

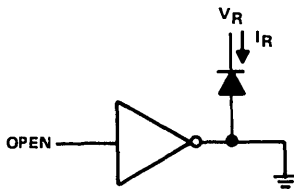

FIGURE 7- $I_R$

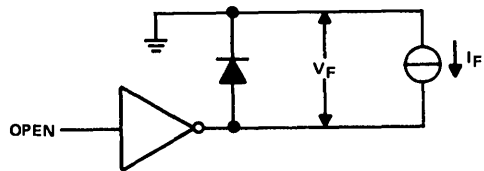
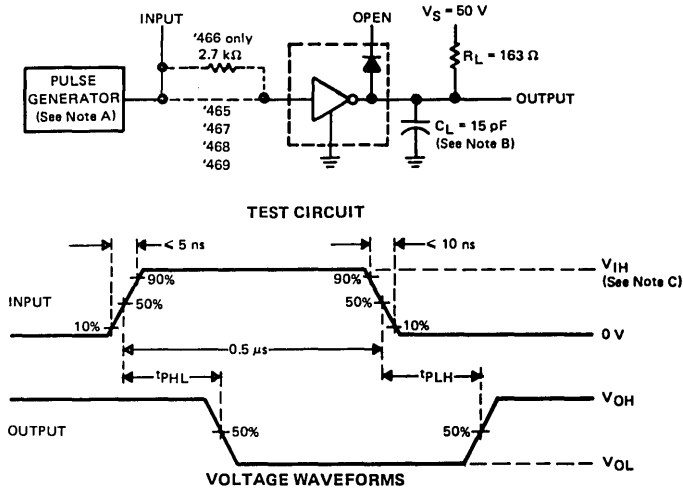

FIGURE 8- $V_F$

# SERIES 75465 DARLINGTON TRANSISTOR ARRAYS

## PARAMETER MEASUREMENT INFORMATION



- NOTES: A. The pulse generator has the following characteristics: PRR = 1 MHz,  $Z_{out} \approx 50 \Omega$ .  
 B.  $C_L$  includes probe and jig capacitance.  
 C. For testing the '465, '466, and '468,  $V_{IH} = 3 \text{ V}$ ; for the '467,  $V_{IH} = 13 \text{ V}$ ; for the '469,  $V_{IH} = 8 \text{ V}$ .

FIGURE 9—PROPAGATION DELAY TIMES

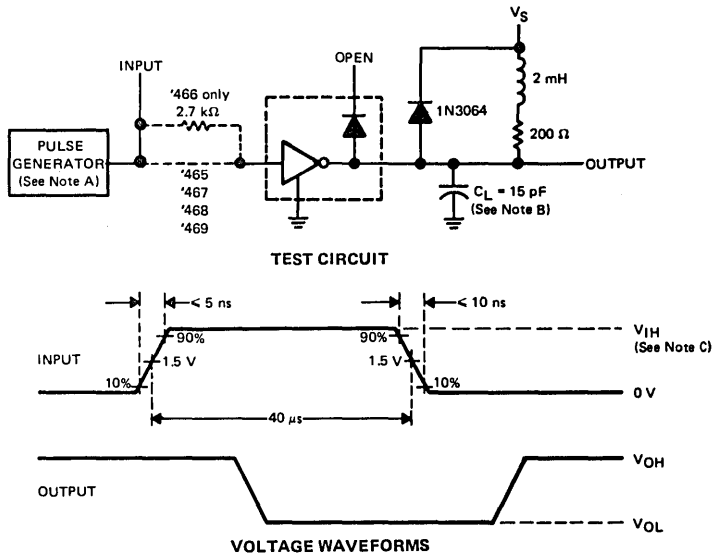

- NOTES: A. The pulse generator has the following characteristics: PRR = 12.5 kHz,  $Z_{out} = 50 \Omega$ .  
 B.  $C_L$  includes probe and jig capacitance.  
 C. For testing the '465, '466, and '468,  $V_{IH} = 3 \text{ V}$ ; for the '467,  $V_{IH} = 13 \text{ V}$ ; for the '469,  $V_{IH} = 8 \text{ V}$ .

FIGURE 10—LATCH-UP TEST

**TEXAS INSTRUMENTS**  
INCORPORATED

POST OFFICE BOX 225012 • DALLAS, TEXAS 75265

# SERIES 75465 DARLINGTON TRANSISTOR ARRAYS

## TYPICAL CHARACTERISTICS

COLLECTOR-EMITTER SATURATION VOLTAGE  
vs  
COLLECTOR CURRENT  
(ONE DARLINGTON)

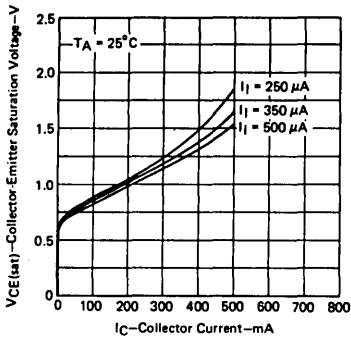

FIGURE 11

COLLECTOR-EMITTER SATURATION VOLTAGE  
vs  
COLLECTOR CURRENT  
(TWO DARLINGTONS PARALLELED)

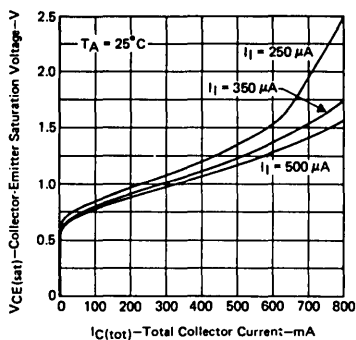

FIGURE 12

COLLECTOR CURRENT  
vs  
INPUT CURRENT

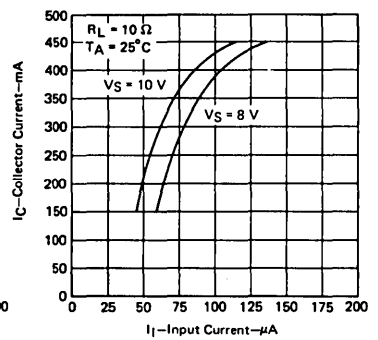

FIGURE 13

## THERMAL INFORMATION

J PACKAGE  
MAXIMUM COLLECTOR CURRENT  
vs  
DUTY CYCLE

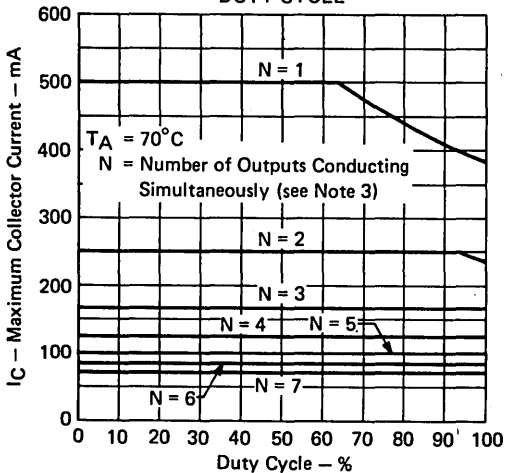

FIGURE 14

N PACKAGE  
MAXIMUM COLLECTOR CURRENT  
vs  
DUTY CYCLE

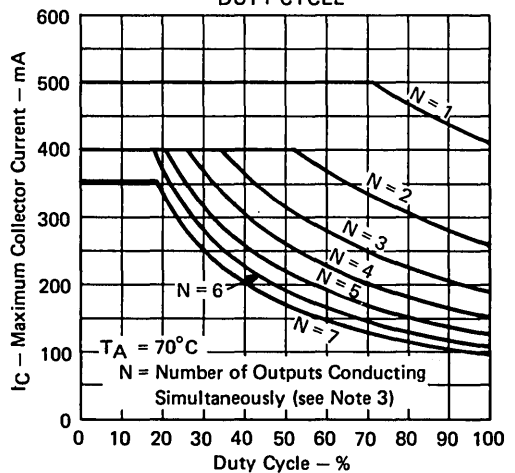
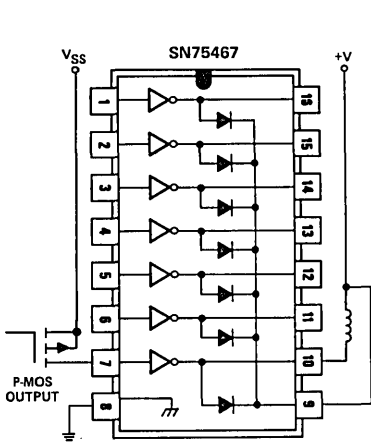

FIGURE 15

NOTE 3: For the J package,  $N \times I_C$  must not exceed 500 mA (maximum substrate current). For the N package  $N \times I_C$  must not exceed 2.5 A.

# SERIES 75465 DARLINGTON TRANSISTOR ARRAYS

## TYPICAL APPLICATION DATA



P-MOS TO LOAD

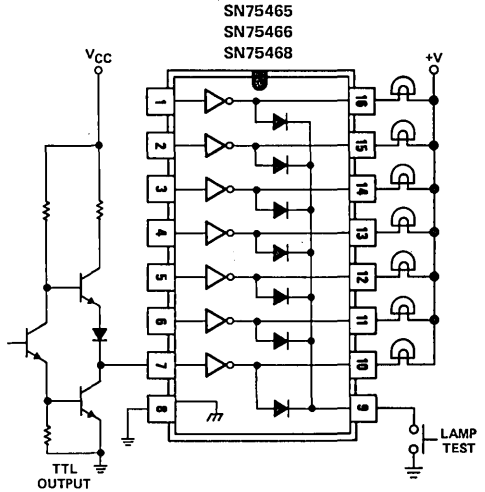

TTL TO LOAD

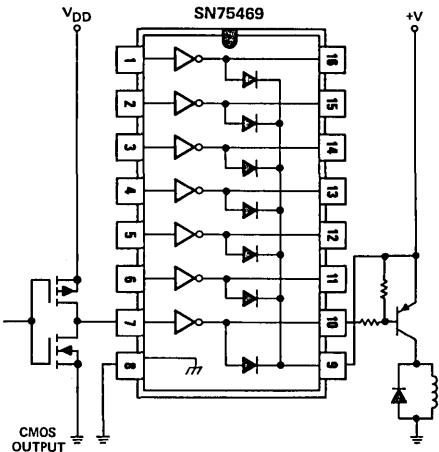

BUFFER FOR  
HIGHER CURRENT LOADS

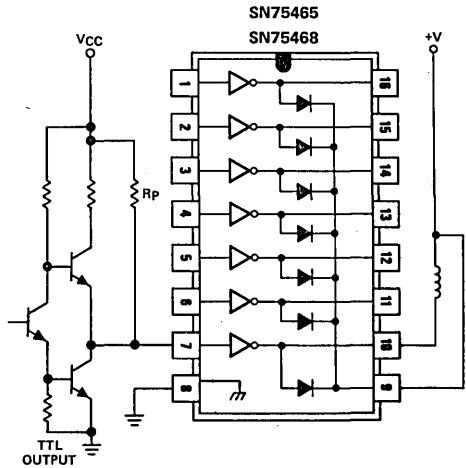

USE OF PULL-UP RESISTORS  
TO INCREASE DRIVE CURRENT

4





**PERIPHERAL DRIVERS FOR  
HIGH-VOLTAGE, HIGH-CURRENT DRIVER APPLICATIONS**

**performance**

- Characterized for Use to 300 mA
- High-Voltage Outputs
- No Output Latch-Up at 55 V (After Conducting 300 mA)
- Medium-Speed Switching

SUMMARY OF SERIES 55470/75470

DEVICE	LOGIC OF COMPLETE CIRCUIT	PACKAGES
SN55470	AND <sup>†</sup>	J
SN55471	AND	JG
SN55472	NAND	JG
SN55473	OR	JG
SN55474	NOR	JG
SN75470	AND <sup>†</sup>	J, N
SN75471	AND	JG, P
SN75472	NAND	JG, P
SN75473	OR	JG, P
SN75474	NOR	JG, P

<sup>†</sup>With output transistor base connected externally to output of gate.

**ease-of-design**

- Circuit Flexibility for Varied Applications and Choice of Logic Function
- TTL- or DTL-Compatible Diode-Clamped Inputs
- Standard Supply Voltages
- Available in Plastic and Ceramic Packages

**description**

Series 55470/75470 dual peripheral drivers are functionally interchangeable with Series 55450B/75450B and Series 55460/75460 peripheral drivers, but are designed for use in systems that require higher breakdown voltages than either of those series can provide at the expense of slightly slower switching speeds than Series 55450B/75450B (limits are the same as Series 55460/75460). Typical applications include logic buffers, power drivers, relay drivers, lamp drivers, MOS drivers, line drivers, and memory drivers. Series 55470 drivers are characterized for operation over the full military temperature range of -55°C to 125°C; Series 75470 drivers are characterized for operation from 0°C to 70°C.

The SN55470 and SN75470 are unique general-purpose devices each featuring two standard Series 54/74 TTL gates and two uncommitted, high-current, high-voltage, n-p-n transistors. These devices offer the system designer the flexibility of tailoring the circuit to the application.

The SN55471/SN75471, SN55472/SN75472, SN55473/SN75473, and SN55474/SN75474 are dual peripheral AND, NAND, OR, and NOR drivers, respectively, (assuming positive logic) with the output of the logic gates internally connected to the bases of the n-p-n output transistors.

CONTENTS	PAGE
Maximum Ratings and Recommended Operating Conditions . . . . .	4-82
Definitive Specifications	
Types SN55470, SN75470 . . . . .	4-83
Types SN55471, SN75471 . . . . .	4-85
Types SN55472, SN75472 . . . . .	4-86
Types SN55473, SN75473 . . . . .	4-87
Types SN55474, SN75474 . . . . .	4-88
Switching Time Test Circuits and Voltage Waveforms . . . . .	4-89

# SERIES 55470/75470

## DUAL PERIPHERAL DRIVERS

absolute maximum ratings over operating free-air temperature range (unless otherwise noted)

	SN55470	SN55471 SN55472 SN55473 SN55474	SN75470	SN75471 SN75472 SN75473 SN75474	UNIT
Supply voltage, $V_{CC}$ (see Note 1)	7	7	7	7	V
Input voltage	5.5	5.5	5.5	5.5	V
Interemitter voltage (see Note 2)	5.5	5.5	5.5	5.5	V
$V_{CC}$ -to-substrate voltage	40		40		V
Collector-to-substrate voltage	70		70		V
Collector-base voltage	70		70		V
Collector-emitter voltage (see Note 3)	70		70		V
Collector-emitter voltage (see Note 4)	40		40		V
Emitter-base voltage	5		5		V
Off-state output voltage		70		70	V
Continuous collector or output current (see Note 5)	400	400	400	400	mA
Peak collector or output current ( $t_w \leq 10$ ms, duty cycle $\leq 50\%$ , see Note 5)	500	500	500	500	mA
Continuous total dissipation at (or below) 25°C free-air temperature (see Note 6)	J package	1375	1025		mW
	JG package			825	
	N package		1150		
	P package			1000	
Operating free-air temperature range	-55 to 125	-55 to 125	0 to 70	0 to 70	°C
Storage temperature range	-65 to 150	-65 to 150	-65 to 150	-65 to 150	°C
Lead temperature 1/16 inch from case for 60 seconds	J or JG package		300	300	°C
Lead temperature 1/16 inch from case for 10 seconds	N or P package		260	260	°C

- NOTES: 1. Voltage values are with respect to network ground terminal unless otherwise specified.  
 2. This is the voltage between two emitters of a multiple-emitter transistor.  
 3. This value applies when the base-emitter resistance ( $R_{BE}$ ) is equal to or less than 500  $\Omega$ .  
 4. This value applies between 0 and 10 mA collector current when the base-emitter diode is open-circuited.  
 5. Both halves of these dual circuits may conduct rated current simultaneously; however, power dissipation averaged over a short time interval must fall within the continuous dissipation rating.  
 6. For operation above 25°C free-air temperature, refer to Dissipation Derating Curves in the Thermal Information Section, which starts on page 2-1. In the J and JG packages, SN55470 through SN55474 chips are alloy-mounted; SN75470 through SN75474 chips are glass-mounted.

recommended operating conditions (see Note 7)

	SERIES 55470			SERIES 75470			UNIT
	MIN	NOM	MAX	MIN	NOM	MAX	
Supply voltage, $V_{CC}$	4.5	5	5.5	4.75	5	5.25	V
Operating free-air temperature, $T_A$	-55		125	0		70	°C

NOTE 7: For SN55470 and SN75470 only, the substrate (pin 8) must always be at the most-negative device voltage for proper operation.

# TYPES SN55470, SN75470 DUAL PERIPHERAL POSITIVE-AND DRIVERS

## schematic

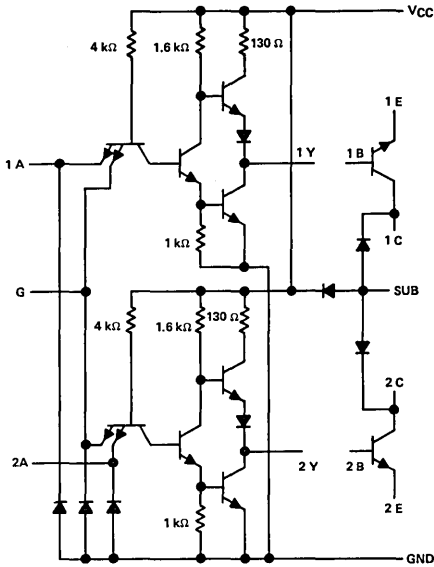

Resistor values shown are nominal.

SN55470 ... J  
SN75470 ... J OR N  
DUAL-IN-LINE PACKAGE (TOP VIEW)

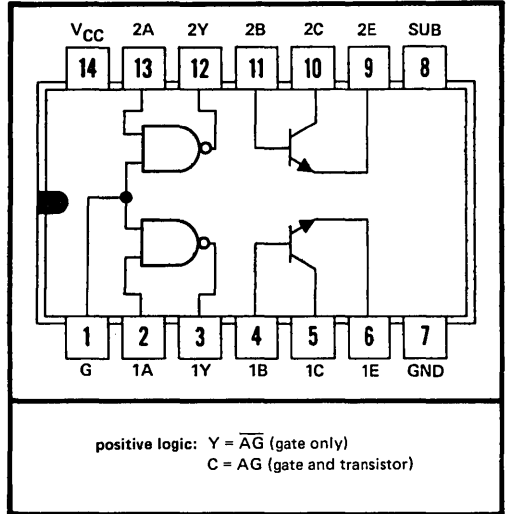

4

## electrical characteristics over recommended operating free-air temperature range (unless otherwise noted)

### TTL gates

PARAMETER		TEST CONDITIONS†	SN55470			SN75470			UNIT
			MIN	TYP‡	MAX	MIN	TYP‡	MAX	
V <sub>IH</sub>	High-level input voltage		2			2			V
V <sub>IL</sub>	Low-level input voltage		0.8			0.8			V
V <sub>IK</sub>	Input clamp voltage	V <sub>CC</sub> = MIN, I <sub>I</sub> = -12 mA	-1.2	-1.5	-1.2	-1.5		V	
V <sub>OH</sub>	High-level output voltage	V <sub>CC</sub> = MIN, V <sub>IL</sub> = 0.8 V, I <sub>OH</sub> = -400 μA	2.4	3.3	2.4	3.3		V	
V <sub>OL</sub>	Low-level output voltage	V <sub>CC</sub> = MIN, V <sub>IH</sub> = 2 V, I <sub>OL</sub> = 16 mA	0.25	0.5	0.25	0.4		V	
I <sub>I</sub>	Input current at maximum input voltage	input A	1			1			mA
		input G	2			2			
I <sub>IH</sub>	High-level input current	input A	40			40			μA
		input G	80			80			
I <sub>IL</sub>	Low-level input current	input A	-1.6			-1.6			mA
		input G	-3.2			-3.2			
I <sub>OS</sub>	Short-circuit output current§	V <sub>CC</sub> = MAX	-18	-35	-55	-18	-35	-55	mA
I <sub>CCH</sub>	Supply current, outputs high	V <sub>CC</sub> = MAX, V <sub>I</sub> = 0	2.8			2.8			4
I <sub>CCL</sub>	Supply current, outputs low	V <sub>CC</sub> = MAX, V <sub>I</sub> = 5 V	7			7			11

† For conditions shown as MIN or MAX, use the appropriate value specified under recommended operating conditions.

‡ All typical values at V<sub>CC</sub> = 5 V, T<sub>A</sub> = 25°C.

§ Not more than one output should be shorted at a time.

# TYPES SN55470, SN75470

## DUAL PERIPHERAL POSITIVE-AND DRIVERS

electrical characteristics over recommended operating free-air temperature range (unless otherwise noted)

### output transistors

PARAMETER	TEST CONDITIONS†	SN55470			SN75470			UNIT
		MIN	TYP‡	MAX	MIN	TYP‡	MAX	
V(BR)CBO	Collector-Base Breakdown Voltage I <sub>C</sub> = 100 μA, I <sub>E</sub> = 0	70			70			V
V(BR)CEO	Collector-Emitter Breakdown Voltage I <sub>C</sub> = 10 mA, I <sub>B</sub> = 0, See Note 8	40			40			V
V(BR)CER	Collector-Emitter Breakdown Voltage I <sub>C</sub> = 100 μA, R <sub>BE</sub> = 500 Ω	70			70			V
V(BR)EBO	Emitter-Base Breakdown Voltage I <sub>E</sub> = 100 μA, I <sub>C</sub> = 0	5			5			V
h <sub>FE</sub>	Static Forward Current Transfer Ratio See Note 8	V <sub>CE</sub> = 3 V, I <sub>C</sub> = 100 mA, T <sub>A</sub> = 25°C	25			25		
		V <sub>CE</sub> = 3 V, I <sub>C</sub> = 300 mA, T <sub>A</sub> = 25°C	30			30		
		V <sub>CE</sub> = 3 V, I <sub>C</sub> = 100 mA, T <sub>A</sub> = MIN	10			20		
		V <sub>CE</sub> = 3 V, I <sub>C</sub> = 300 mA, T <sub>A</sub> = MIN	15			25		
V <sub>BE</sub>	Base-Emitter Voltage I <sub>B</sub> = 10 mA, I <sub>C</sub> = 100 mA	See Note 8	0.85	1.2	0.85	1		V
		I <sub>B</sub> = 30 mA, I <sub>C</sub> = 300 mA	1	1.4	1	1.2		
V <sub>CE(sat)</sub>	Collector-Emitter Saturation Voltage I <sub>B</sub> = 10 mA, I <sub>C</sub> = 100 mA	See Note 8	0.25	0.5	0.25	0.4		V
		I <sub>B</sub> = 30 mA, I <sub>C</sub> = 300 mA	0.45	0.8	0.45	0.7		

†For conditions shown as MIN or MAX, use the appropriate value specified under recommended operating conditions.

‡All typical values are at V<sub>CC</sub> = 5 V, T<sub>A</sub> = 25°C.

NOTE 8: These parameters must be measured using pulse techniques. t<sub>w</sub> = 300 μs, duty cycle ≤ 2%.

### switching characteristics, V<sub>CC</sub> = 5 V, T<sub>A</sub> = 25°C

#### TTL gates

PARAMETER	TEST CONDITIONS	MIN	TYP	MAX	UNIT
t <sub>PLH</sub>	Propagation delay time, low-to-high-level output C <sub>L</sub> = 15 pF, R <sub>L</sub> = 400 Ω, See Figure 1		22		ns
t <sub>PHL</sub>	Propagation delay time, high-to-low-level output		8		ns

#### output transistors

PARAMETER	TEST CONDITIONS‡	MIN	TYP	MAX	UNIT
t <sub>d</sub>	I <sub>C</sub> = 200 mA, I <sub>B</sub> (1) = 20 mA, I <sub>B</sub> (2) = -40 mA, V <sub>BE(off)</sub> = -1 V, C <sub>L</sub> = 15 pF, R <sub>L</sub> = 50 Ω, See Figure 2		10		ns
t <sub>r</sub>			16		ns
t <sub>s</sub>			23		ns
t <sub>f</sub>			14		ns

‡Voltage and current values shown are nominal; exact values vary slightly with transistor parameters.

#### gates and transistors combined

PARAMETER	TEST CONDITIONS	MIN	TYP	MAX	UNIT
t <sub>PLH</sub>	I <sub>C</sub> ≈ 200 mA, C <sub>L</sub> = 15 pF, R <sub>L</sub> = 50 Ω, See Figure 3		45	65	ns
t <sub>PHL</sub>			35	50	ns
t <sub>TLH</sub>			10	20	ns
t <sub>THL</sub>			10	20	ns
V <sub>OH</sub>	V <sub>S</sub> = 55 V, I <sub>C</sub> ≈ 300 mA, R <sub>BE</sub> = 500 Ω, See Figure 4	V <sub>S</sub> -18			mV

# TYPES SN55471, SN75471 DUAL PERIPHERAL POSITIVE-AND DRIVERS

logic

FUNCTION TABLE  
(EACH DRIVER)

A	B	Y
L	L	L (on state)
L	H	L (on state)
H	L	L (on state)
H	H	H (off state)

H = high level, L = low level

SN55471...JG  
SN75471...JG OR P  
DUAL-IN-LINE PACKAGE (TOP VIEW)

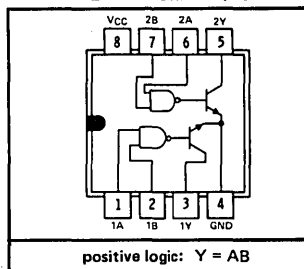

schematic (each driver)

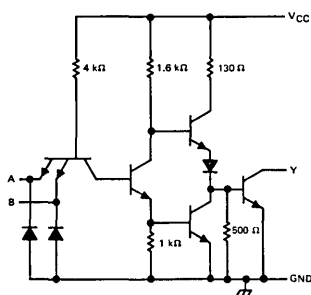

Resistor values shown are nominal.

electrical characteristics over recommended operating free-air temperature range (unless otherwise noted)

PARAMETER	TEST CONDITIONS†	SN55471			SN75471			UNIT
		MIN	TYP‡	MAX	MIN	TYP‡	MAX	
V <sub>IH</sub>	High-level input voltage	2			2			V
V <sub>IL</sub>	Low-level input voltage			0.8			0.8	V
V <sub>IK</sub>	Input clamp voltage	V <sub>CC</sub> = MIN, I <sub>I</sub> = -12 mA		-1.2 -1.5	-1.2 -1.5			V
I <sub>OH</sub>	High-level output current	V <sub>CC</sub> = MIN, V <sub>IH</sub> = 2 V, V <sub>OH</sub> = 70 V		300	100			μA
V <sub>OL</sub>	Low-level output voltage	V <sub>CC</sub> = MIN, V <sub>IL</sub> = 0.8 V, I <sub>OL</sub> = 100 mA		0.25 0.5	0.25 0.4		V	
		V <sub>CC</sub> = MIN, V <sub>IL</sub> = 0.8 V, I <sub>OL</sub> = 300 mA		0.5 0.8	0.5 0.7			
I <sub>I</sub>	Input current at maximum input voltage	V <sub>CC</sub> = MAX, V <sub>I</sub> = 5.5 V		1	1		mA	
I <sub>IH</sub>	High-level input current	V <sub>CC</sub> = MAX, V <sub>I</sub> = 2.4 V		40	40		μA	
I <sub>IL</sub>	Low-level input current	V <sub>CC</sub> = MAX, V <sub>I</sub> = 0.4 V		-1 -1.6	-1 -1.6		mA	
I <sub>CCH</sub>	Supply current, outputs high	V <sub>CC</sub> = MAX, V <sub>I</sub> = 5 V		8 11	8 11		mA	
I <sub>CCL</sub>	Supply current, outputs low	V <sub>CC</sub> = MAX, V <sub>I</sub> = 0		56 76	56 76		mA	

† For conditions shown as MIN or MAX, use the appropriate value specified under recommended operating conditions.

‡ All typical values are at V<sub>CC</sub> = 5 V, T<sub>A</sub> = 25°C.

switching characteristics, V<sub>CC</sub> = 5 V, T<sub>A</sub> = 25°C

PARAMETER	TEST CONDITIONS	MIN	TYP	MAX	UNIT
t <sub>PLH</sub>	I <sub>O</sub> ≈ 200 mA, C <sub>L</sub> = 15 pF, R <sub>L</sub> = 50 Ω, See Figure 3		30	55	ns
t <sub>PHL</sub>			25	40	ns
t <sub>TLH</sub>			8	20	ns
t <sub>THL</sub>			10	20	ns
V <sub>OH</sub>	V <sub>S</sub> = 55 V, See Figure 4, I <sub>O</sub> ≈ 300 mA	V <sub>S</sub> -18			mV

TEXAS INSTRUMENTS  
INCORPORATED

POST OFFICE BOX 225012 • DALLAS, TEXAS 75265

# TYPES SN55472, SN75472 DUAL PERIPHERAL POSITIVE-NAND DRIVERS

logic

FUNCTION TABLE  
(EACH DRIVER)

A	B	Y
L	L	H (off state)
L	H	H (off state)
H	L	H (off state)
H	H	L (on state)

H = high level, L = low level

SN55472 ... JG  
SN75472 ... JG OR P  
DUAL-IN-LINE PACKAGE (TOP VIEW)

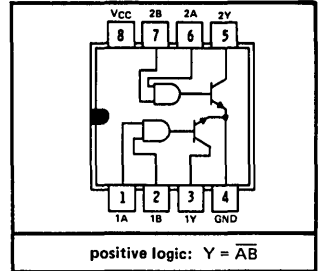

schematic (each driver)

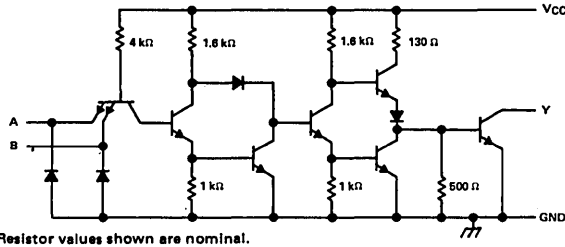

Resistor values shown are nominal.

electrical characteristics over recommended operating free-air temperature range (unless otherwise noted)

PARAMETER	TEST CONDITIONS	SN55472		SN75472		UNIT
		MIN	TYP†	MAX	MIN	
V <sub>IH</sub>	High-level input voltage	2		2		V
V <sub>IL</sub>	Low-level input voltage			0.8		0.8 V
V <sub>IK</sub>	Input clamp voltage	V <sub>CC</sub> = MIN, I <sub>I</sub> = -12 mA		-1.2	-1.5	V
I <sub>OH</sub>	High-level output current	V <sub>CC</sub> = MIN, V <sub>IL</sub> = 0.8 V, V <sub>OH</sub> = 70 V		300		100 μA
V <sub>OL</sub>	Low-level output voltage	V <sub>CC</sub> = MIN, V <sub>IH</sub> = 2 V, I <sub>OL</sub> = 100 mA		0.25	0.5	V
		V <sub>CC</sub> = MIN, V <sub>IH</sub> = 2 V, I <sub>OL</sub> = 300 mA		0.5	0.8	
I <sub>I</sub>	Input current at maximum input voltage	V <sub>CC</sub> = MAX, V <sub>I</sub> = 5.5 V		1		1 mA
I <sub>IH</sub>	High-level input current	V <sub>CC</sub> = MAX, V <sub>I</sub> = 2.4 V		40		40 μA
I <sub>IL</sub>	Low-level input current	V <sub>CC</sub> = MAX, V <sub>I</sub> = 0.4 V		-1.1	-1.6	-1.1 -1.6 mA
I <sub>CCH</sub>	Supply current, outputs high	V <sub>CC</sub> = MAX, V <sub>I</sub> = 0 V		13	17	13 17 mA
I <sub>CCL</sub>	Supply current, outputs low	V <sub>CC</sub> = MAX, V <sub>I</sub> = 5V		61	76	61 76 mA

† For conditions shown as MIN or MAX, use the appropriate value specified under recommended operating conditions.

‡ All typical values are at V<sub>CC</sub> = 5 V, T<sub>A</sub> = 25°C.

switching characteristics, V<sub>CC</sub> = 5 V, T<sub>A</sub> = 25°C

PARAMETER	TEST CONDITIONS	MIN	TYP	MAX	UNIT	
t <sub>PLH</sub>	Propagation delay time, low-to-high-level output		45	65	ns	
t <sub>PHL</sub>	Propagation delay time, high-to-low-level output	I <sub>O</sub> ≈ 200 mA, C <sub>L</sub> = 15 pF,		30	50	ns
t <sub>TLH</sub>	Transition time, low-to-high-level output	R <sub>L</sub> = 50 Ω, See Figure 3		13	25	ns
t <sub>THL</sub>	Transition time, high-to-low-level output			10	20	ns
V <sub>OH</sub>	High-level output voltage after switching	V <sub>S</sub> = 55 V, I <sub>O</sub> ≈ 300 mA, See Figure 4		V <sub>S</sub> -18		mV

# TYPES SN55473, SN75473 DUAL PERIPHERAL POSITIVE-OR DRIVERS

## logic

**FUNCTION TABLE  
(EACH DRIVER)**

A	B	Y
L	L	L (on state)
L	H	H (off state)
H	L	H (off state)
H	H	H (off state)

H = high level, L = low level

SN55473 ... JG  
SN75473 ... JG OR P  
DUAL-IN-LINE PACKAGE (TOP VIEW)

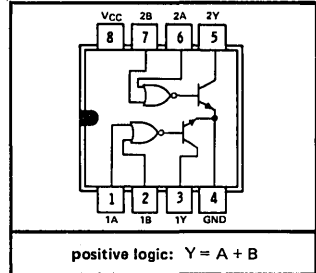

## schematic (each driver)

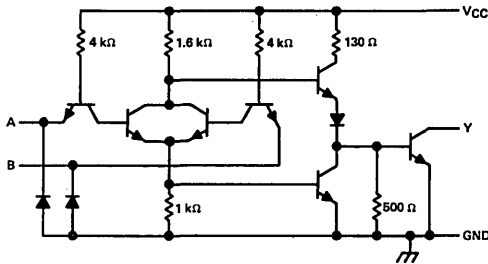

Resistor values shown are nominal.

## electrical characteristics over recommended operating free-air temperature range (unless otherwise noted)

PARAMETER	TEST CONDITIONS†	SN55473		SN75473		UNIT
		MIN	TYP‡	MAX	MIN	
$V_{IH}$ High-level input voltage		2		2		V
$V_{IL}$ Low-level input voltage		0.8		0.8		V
$V_{IK}$ Input clamp voltage	$V_{CC} = \text{MIN}, I_I = -12 \text{ mA}$	-1.2	-1.5	-1.2	-1.5	V
$I_{OH}$ High-level output current	$V_{CC} = \text{MIN}, V_{IH} = 2 \text{ V}, V_{OH} = 70 \text{ V}$	300		100		$\mu\text{A}$
$V_{OL}$ Low-level output voltage	$V_{CC} = \text{MIN}, V_{IL} = 0.8 \text{ V}, I_{OL} = 100 \text{ mA}$	0.25	0.5	0.25	0.4	V
	$V_{CC} = \text{MIN}, V_{IL} = 0.8 \text{ V}, I_{OL} = 300 \text{ mA}$	0.5	0.8	0.5	0.7	
$I_I$ Input current at maximum input voltage	$V_{CC} = \text{MAX}, V_I = 5.5 \text{ V}$	1		1		mA
$I_{IH}$ High-level input current	$V_{CC} = \text{MAX}, V_I = 2.4 \text{ V}$	40		40		$\mu\text{A}$
$I_{IL}$ Low-level input current	$V_{CC} = \text{MAX}, V_I = 0.4 \text{ V}$	-1	-1.6	-1	-1.6	mA
$I_{CCH}$ Supply current, outputs high	$V_{CC} = \text{MAX}, V_I = 5 \text{ V}$	8	11	8	11	mA
$I_{CCL}$ Supply current, outputs low	$V_{CC} = \text{MAX}, V_I = 0$	58	76	58	76	mA

†For conditions shown as MIN or MAX, use the appropriate value specified under recommended operating conditions.

‡All typical values are at  $V_{CC} = 5 \text{ V}, T_A = 25^\circ\text{C}$ .

## switching characteristics, $V_{CC} = 5 \text{ V}, T_A = 25^\circ\text{C}$

PARAMETER	TEST CONDITIONS	MIN	TYP	MAX	UNIT
$t_{PLH}$ Propagation delay time, low-to-high-level output	$I_O \approx 200 \text{ mA}, C_L = 15 \text{ pF}, R_L = 50 \Omega,$ See Figure 3		30	55	ns
$t_{PHL}$ Propagation delay time, high-to-low-level output			25	40	ns
$t_{TLH}$ Transition time, low-to-high-level output			8	25	ns
$t_{THL}$ Transition time, high-to-low-level output			10	25	ns
$V_{OH}$ High-level output voltage after switching	$V_S = 55 \text{ V}, I_O \approx 300 \text{ mA},$ See Figure 4	$V_S - 18$			mV

**TEXAS INSTRUMENTS**  
INCORPORATED

POST OFFICE BOX 225012 • DALLAS, TEXAS 75265

# TYPES SN55474, SN75474

## DUAL PERIPHERAL POSITIVE-NOR DRIVERS

logic

FUNCTION TABLE  
(EACH DRIVER)

A	B	Y
L	L	H (off state)
L	H	L (on state)
H	L	L (on state)
H	H	L (on state)

H = high level, L = low level

SN55474 ... JG  
SN75474 ... JG OR P  
DUAL-IN-LINE PACKAGE (TOP VIEW)

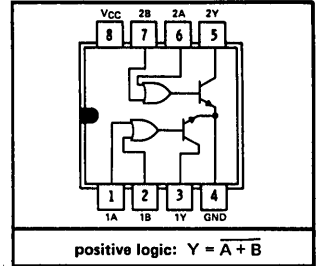

schematic (each driver)

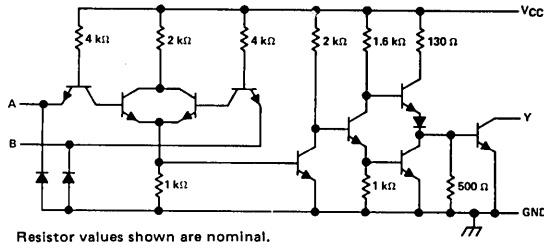

electrical characteristics over recommended operating free-air temperature range (unless otherwise noted)

PARAMETER	TEST CONDITIONS†	SN55474		SN75474		UNIT		
		MIN	TYP‡	MAX	MIN		TYP‡	MAX
$V_{IH}$ High-level input voltage		2		0.8	2		V	
$V_{IL}$ Low-level input voltage				0.8		0.8	V	
$V_{IK}$ Input clamp voltage	$V_{CC} = \text{MIN}$ , $I_I = -12 \text{ mA}$	-1.2	-1.5	-1.2	-1.5		V	
$I_{OH}$ High-level output current	$V_{CC} = \text{MIN}$ , $V_{IL} = 0.8 \text{ V}$ , $V_{OH} = 70 \text{ V}$		300		100		$\mu\text{A}$	
$V_{OL}$ Low-level output voltage	$V_{CC} = \text{MIN}$ , $V_{IH} = 2 \text{ V}$ , $I_{OL} = 100 \text{ mA}$	0.25	0.5	0.25	0.4		V	
	$V_{CC} = \text{MIN}$ , $V_{IH} = 2 \text{ V}$ , $I_{OL} = 300 \text{ mA}$	0.5	0.8	0.5	0.7			
$I_I$ Input current at maximum input voltage	$V_{CC} = \text{MAX}$ , $V_I = 5.5 \text{ V}$		1			1	$\text{mA}$	
$I_{IH}$ High-level input current	$V_{CC} = \text{MAX}$ , $V_I = 2.4 \text{ V}$		40			40	$\mu\text{A}$	
$I_{IL}$ Low-level input current	$V_{CC} = \text{MAX}$ , $V_I = 0.4 \text{ V}$		-1	-1.6		-1	-1.6	$\text{mA}$
$I_{CCH}$ Supply current, outputs high	$V_{CC} = \text{MAX}$ , $V_I = 0 \text{ V}$	14	19	14	19		$\text{mA}$	
$I_{CCL}$ Supply current, outputs low	$V_{CC} = \text{MAX}$ , $V_I = 5 \text{ V}$	67	85	67	85		$\text{mA}$	

†For conditions shown as MIN or MAX, use the appropriate value specified under recommended operating conditions.  
‡All typical values are at  $V_{CC} = 5 \text{ V}$ ,  $T_A = 25^\circ\text{C}$ .

switching characteristics,  $V_{CC} = 5 \text{ V}$ ,  $T_A = 25^\circ\text{C}$

PARAMETER	TEST CONDITIONS	MIN	TYP	MAX	UNIT
$t_{PLH}$ Propagation delay time, low-to-high-level output	$I_O \approx 200 \text{ mA}$ , $C_L = 15 \text{ pF}$ , $R_L = 50 \Omega$ , See Figure 3		40	65	ns
$t_{PHL}$ Propagation delay time, high-to-low-level output			30	50	ns
$t_{TLH}$ Transition time, low-to-high-level output			8	20	ns
$t_{THL}$ Transition time, high-to-low-level output			10	20	ns
$V_{OH}$ High-level output voltage after switching	$V_S = 55 \text{ V}$ , See Figure 4	$V_S - 18$			mV



# SERIES 55470/75470 DUAL PERIPHERAL DRIVERS

## PARAMETER MEASUREMENT INFORMATION

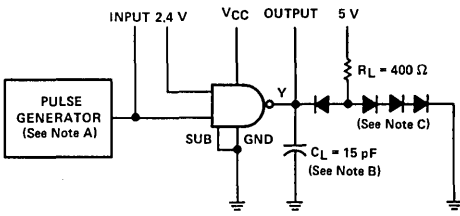

**TEST CIRCUIT**

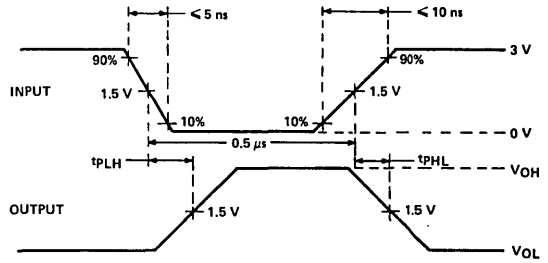

**VOLTAGE WAVEFORMS**

- NOTES: A. The pulse generator has the following characteristics: PRR = 1 MHz,  $Z_{out} \approx 50 \Omega$ .  
 B.  $C_L$  include probe and jig capacitance.  
 C. All diodes are 1N3064.

**FIGURE 1—PROPAGATION DELAY TIMES, EACH GATE (SN55470 AND SN75470 ONLY)**

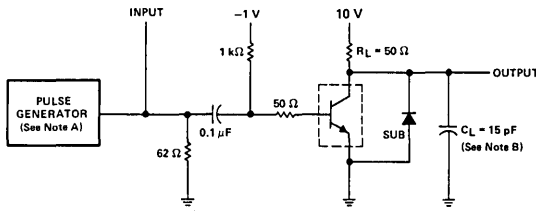

**TEST CIRCUIT**

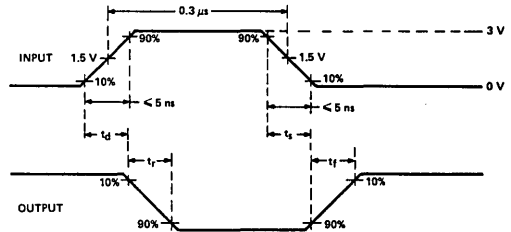

**VOLTAGE WAVEFORMS**

- NOTES: A. The pulse generator has the following characteristics: duty cycle  $\leq 1\%$ ,  $Z_{out} \approx 50 \Omega$ .  
 B.  $C_L$  includes probe and jig capacitance.

**FIGURE 2—SWITCHING TIMES, EACH TRANSISTOR (SN55470 AND SN75470 ONLY)**

# SERIES 55470/75470 DUAL PERIPHERAL DRIVERS

## PARAMETER MEASUREMENT INFORMATION

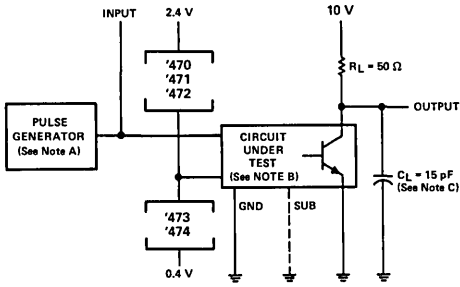

TEST CIRCUIT

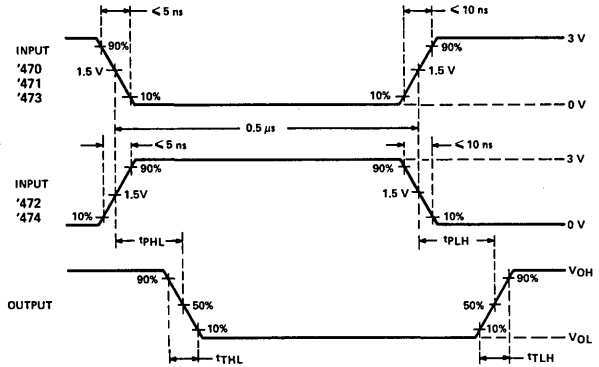

VOLTAGE WAVEFORMS

- NOTES: A. The pulse generator has the following characteristics: PRR = 1 MHz,  $Z_{out} \approx 50 \Omega$   
 B. When testing SN55470 or SN75470, connect output Y to transistor base and ground the substrate terminal.  
 C.  $C_L$  includes probe and jig capacitance.

FIGURE 3—SWITCHING TIMES OF COMPLETE DRIVERS

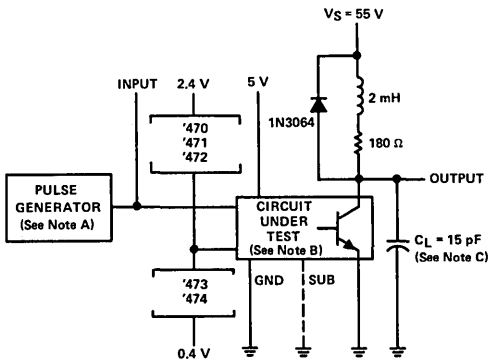

TEST CIRCUIT

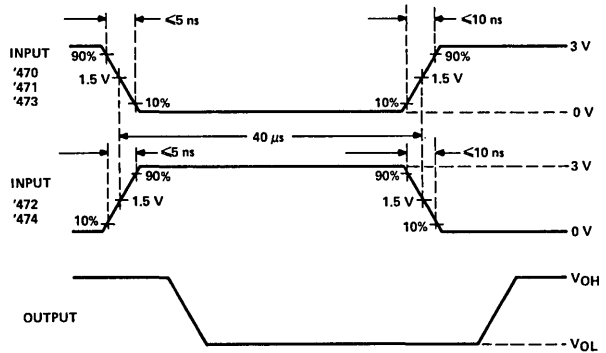

VOLTAGE WAVEFORMS

- NOTES: A. The pulse generator has the following characteristics: PRR = 12.5 kHz,  $Z_{out} = 50 \Omega$ .  
 B. When testing SN55470 or SN75470, connect output Y to transistor base with a 500- $\Omega$  resistor from there to ground, and ground the substrate terminal.  
 C.  $C_L$  includes probe and jig capacitance.

FIGURE 4—LATCH-UP TEST OF COMPLETE DRIVERS

# INTERFACE CIRCUITS

# SERIES 75476 DUAL PERIPHERAL DRIVERS

BULLETIN NO. DL-S 12480, DECEMBER 1976 — REVISED AUGUST 1977

JG OR P DUAL-IN-LINE PACKAGE  
(TOP VIEW)

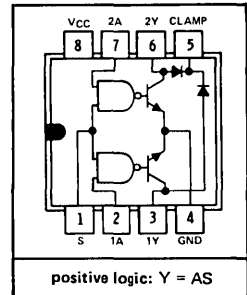

positive logic:  $Y = AS$

JG OR P DUAL-IN-LINE PACKAGE  
(TOP VIEW)

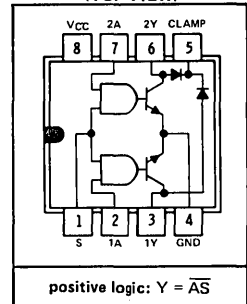

positive logic:  $Y = A\bar{S}$

JG OR P DUAL-IN-LINE PACKAGE  
(TOP VIEW)

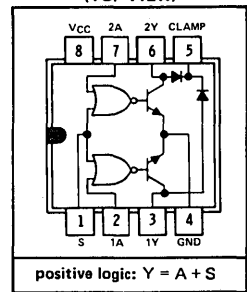

positive logic:  $Y = A + S$

JG OR P DUAL-IN-LINE PACKAGE  
(TOP VIEW)

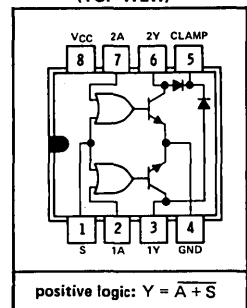

positive logic:  $Y = \bar{A} + \bar{S}$

- Characterized for Use to 300 mA
- No Output Latch-Up at 55 V (After Conducting 300 mA)
- High-Voltage Outputs (100 V Typical)
- High-Speed Switching
- Output Clamp Diodes for Transient Suppression (300 mA, 70 V)
- TTL- or MOS-Compatible Diode-Clamped Inputs
- P-N-P Inputs Reduce Input Current
- Standard Supply Voltage
- Suitable for Hammer-Driver Applications

## description

Series 75476 dual peripheral drivers are designed for use in systems that require high current, high voltage, and fast switching times. The SN75476, SN75477, SN75478, and SN75479 provide AND, NAND, OR, and NOR drivers, respectively. These devices have diode-clamped inputs as well as high-current, high-voltage inductive-clamp diodes on the outputs.

Series 75476 drivers are characterized for operation from 0°C to 70°C.

## schematics of inputs and outputs

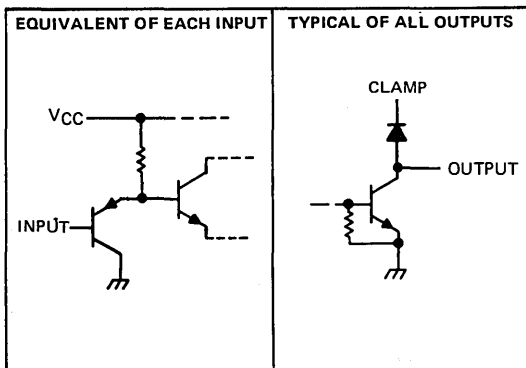

SN75476  
FUNCTION TABLE  
(EACH AND DRIVER)

INPUTS		OUTPUT
A	S	Y
L	L	L
L	H	L
H	L	L
H	H	H

H = high level

L = low level

SN75477  
FUNCTION TABLE  
(EACH NAND DRIVER)

INPUTS		OUTPUT
A	S	Y
L	L	H
L	H	H
H	L	H
H	H	L

H = high level

L = low level

SN75478  
FUNCTION TABLE  
(EACH OR DRIVER)

INPUTS		OUTPUT
A	S	Y
L	L	L
L	H	H
H	L	H
H	H	H

H = high level

L = low level

SN75479  
FUNCTION TABLE  
(EACH NOR DRIVER)

INPUTS		OUTPUT
A	S	Y
L	L	H
L	H	L
H	L	L
H	H	L

H = high level

L = low level

TEXAS INSTRUMENTS  
INCORPORATED

POST OFFICE BOX 225012 • DALLAS, TEXAS 75265

# SERIES 75476

## DUAL PERIPHERAL DRIVERS

### absolute maximum ratings over operating free-air temperature range (unless otherwise noted)

Supply voltage, $V_{CC}$ (see Note 1)	7 V
Input voltage	5.5 V
Continuous output current (see Note 2)	400 mA
Peak output current: $t_W \leq 10$ ms, duty cycle $\leq 50\%$	500 mA
$t_W \leq 30$ ns, duty cycle $\leq 0.002\%$	3 A
Output clamp diode current	400 mA
Continuous total dissipation at (or below) 25°C free-air temperature (see Note 3):	
JG package	825 mW
P package	1000 mW
Operating free-air temperature	0°C to 70°C
Storage temperature range	-65°C to 150°C
Lead temperature 1/16 inch from case for 60 seconds: JG package	300°C
Lead temperature 1/16 inch from case for 10 seconds: P package	260°C

4

### recommended operating conditions

	MIN	NOM	MAX	UNIT
Supply voltage, $V_{CC}$	4.5	5	5.5	V
Operating free-air temperature	0		70	°C

- NOTES: 1. Voltage values are with respect to network ground terminal.  
 2. Both halves of this dual circuit may conduct rated current simultaneously; however, power dissipation averaged over a short time interval must fall within the continuous dissipation ratings.  
 3. For operation above 25°C free-air temperature, refer to Dissipation Derating Curves in the Thermal Information section, which starts on page 2-1. In the JG package, SN75476 through SN75479 chips are glass-mounted.

### electrical characteristics over recommended operating free-air temperature range (unless otherwise noted)

PARAMETER		TEST CONDITIONS	MIN	TYP†	MAX	UNIT	
$V_{IH}$	High-level input voltage		2			V	
$V_{IL}$	Low-level input voltage				0.8	V	
$V_{IK}$	Input clamp voltage	$I_I = -12$ mA	-0.95		-1.5	V	
$I_{OH}$	High-level output current	$V_{CC} = 4.5$ V, $V_{IH} = 2$ V, $V_{IL} = 0.8$ V, $V_{OH} = 70$ V		1	100	$\mu$ A	
$V_{OL}$	Low-level output voltage	$V_{CC} = 4.5$ V, $I_{OL} = 100$ mA	0.16		0.3	V	
		$V_{IH} = 2$ V, $I_{OL} = 175$ mA	0.22		0.5		
		$V_{IL} = 0.8$ V, $I_{OL} = 300$ mA	0.33		0.6		
$V_{(BR)O}$	Output breakdown voltage	$V_{CC} = 4.5$ V, $I_{OH} = 100$ $\mu$ A	70	100		V	
$V_{R(K)}$	Output clamp diode reverse voltage	$V_{CC} = 4.5$ V, $I_R = 100$ $\mu$ A	70	100		V	
$V_{F(K)}$	Output clamp diode forward voltage	$V_{CC} = 4.5$ V, $I_F = 300$ mA	0.8	1.15	1.6	V	
$I_{IH}$	High-level input current	$V_{CC} = 5.5$ V, $V_I = 5.5$ V		0.01	10	$\mu$ A	
$I_{IL}$	Low-level input current	A input		-80	-110	$\mu$ A	
		Strobe S	$V_{CC} = 5.5$ V, $V_I = 0.8$ V	-160	-220		
$I_{CCH}$	Supply current, outputs high	SN75476	$V_{CC} = 5.5$ V	$V_I = 5$ V	10	17	mA
		SN75477		$V_I = 0$	10	17	
		SN75478		$V_I = 5$ V	10	17	
		SN75479		$V_I = 0$	10	17	
$I_{CCL}$	Supply current, outputs low	SN75476	$V_{CC} = 5.5$ V	$V_I = 0$	54	75	mA
		SN75477		$V_I = 5$ V	54	75	
		SN75478		$V_I = 0$	54	75	
		SN75479		$V_I = 5$ V	54	75	
				$V_I = 0$	54	75	

† All typical values are at  $V_{CC} = 5$  V,  $T_A = 25^\circ$ C.

switching characteristics,  $V_{CC} = 5\text{ V}$ ,  $T_A = 25^\circ\text{ C}$

PARAMETER	TEST CONDITIONS	SN75476		SN75477		SN75478		SN75479		UNIT
		MIN	TYP	MAX	MIN	TYP	MAX	MIN	TYP	
$t_{PLH}$ Propagation delay time, low-to-high-level output	$C_L = 30\text{ pF}$ , $R_L = 100\ \Omega$ , See Figure 1	100	200	100	200	100	200	100	200	ns
$t_{PHL}$ Propagation delay time, high-to-low-level output		200	300	200	300	200	300	200	300	ns
$t_{TLH}$ Transition time, low-to-high-level output		50	100	50	100	50	100	50	100	ns
$t_{THL}$ Transition time, high-to-low-level output		50	100	50	100	50	100	50	100	ns
$V_{OH}$ High-level output voltage after switching	$V_S = 55\text{ V}$ , $I_O \approx 300\text{ mA}$ , See Figure 2	$V_S - 18$		$V_S - 18$		$V_S - 18$		$V_S - 18$		mV

PARAMETER MEASUREMENT INFORMATION

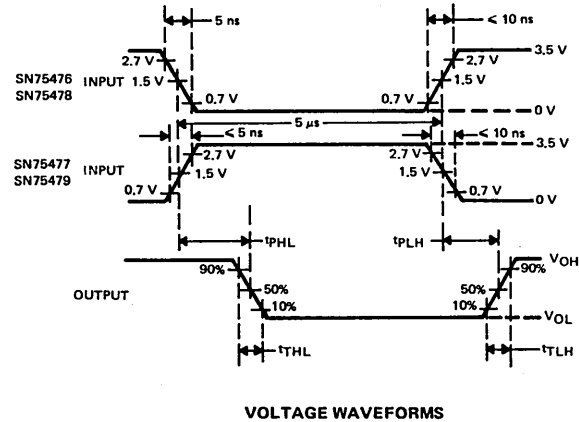
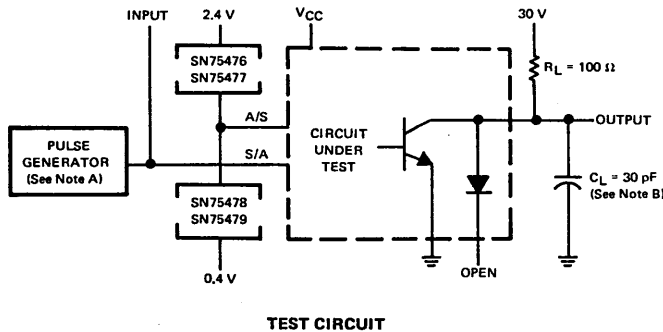

NOTES: A. The pulse generator has the following characteristics: PRR = 1 MHz,  $Z_{out} = 50\ \Omega$ .  
B.  $C_L$  includes probe and jig capacitance.

FIGURE 1—SWITCHING CHARACTERISTICS

TEXAS INSTRUMENTS  
INCORPORATED  
POST OFFICE BOX 228012 • DALLAS, TEXAS 75285

SERIES 75476  
DUAL PERIPHERAL DRIVERS

# SERIES 75476 DUAL PERIPHERAL DRIVERS

## PARAMETER MEASUREMENT INFORMATION

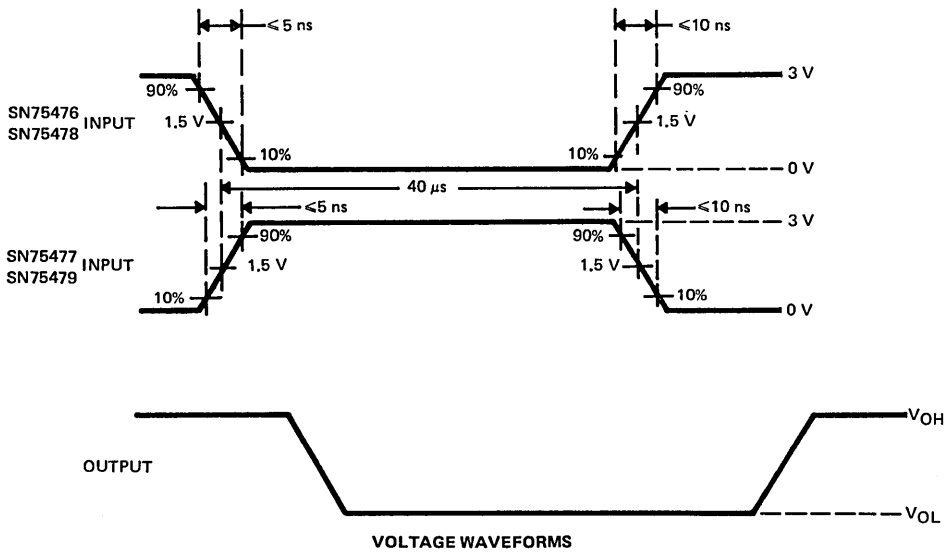
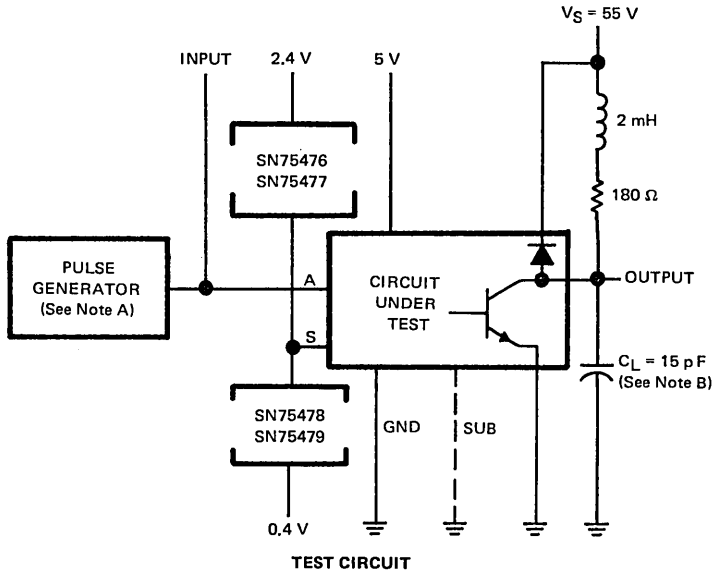

NOTES: A. The pulse generator has the following characteristics: PRR = 12.5 kHz,  $Z_{out} = 50 \Omega$ .  
B.  $C_L$  includes probe and jig capacitance.

FIGURE 2—LATCH-UP TEST

# INTERFACE CIRCUITS

# TYPES UDN2841, UDN2845 QUADRUPLE HIGH-CURRENT DARLINGTON DRIVERS

BULLETIN NO. DL-S 12791, DECEMBER 1980

- For Use with Negative Supplies
- Current Sink . . . UDN2841
- Sink or Source Combination . . . UDN2845
- Output Current Capability . . . 1.5 A
- High Output-Voltage Capability . . . 50 V
- Preamplifier for High Current Gain
- Inputs Compatible With TTL, DTL, and 5-V CMOS
- Reliable Monolithic Construction
- Designed to be Interchangeable with Sprague UDN2841 and UDN2845

## description

The quadruple darlington switches are monolithic bipolar devices especially designed for high-current, high-voltage peripheral driver applications. The devices are designed to offer solutions to interface problems involving electronic-discharge printers, bipolar and unipolar dc motor drivers, telephone relays, LEDs, PIN diodes, and other high-current loads operating from negative power supplies.

The UDN2841 is intended for current-sink applications with the load connected to ground and the device switching the negative supply. The UDN2845 is a sink and source combination for use in bipolar switching applications where both ends of the load are floating. The UDN2841 and UDN2845 each feature inputs that are compatible with standard TTL, DTL, and 5-volt CMOS signals. The p-n-p input transistor serves as a level translator and the first n-p-n transistor stage is designed to provide sufficient current gain to drive the output darlington-connected pair.

Driver channels 2 and 4 have uncommitted collectors and emitters while channels 1 and 3 have emitters internally connected to the substrate. For proper operation these emitters and the substrate must be connected to the most-negative supply voltage.

The UDN2841 and UDN2845 are characterized for operation from 0°C to 70°C.

## absolute maximum ratings at 25°C free-air temperature (unless otherwise noted)

Collector-emitter voltage	50 V
Supply voltage, V <sub>CC</sub> (see Note 1)	10 V
Input voltage	10 V
Substrate voltage	-50 V
Peak output current	1.75 A
Total power dissipation at (or below) 25°C free-air temperature (see Note 2)	2075 mW
Operating free-air temperature range	0°C to 70°C
Storage temperature range	-55°C to 150°C
Lead temperature 1/16 inch from case for 10 seconds	260°C

- NOTES: 1. All voltage values, except collector-emitter voltage, are with respect to the network ground terminal.  
2. For operation above 25°C free-temperature, derate to 1328 mW at 70°C at the rate of 16.6 mW/°C.

NE DUAL-IN-LINE PACKAGE  
(TOP VIEW)

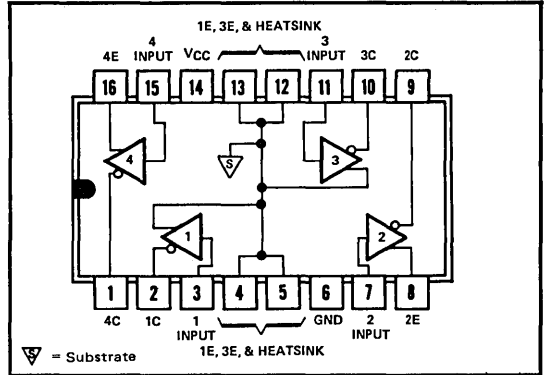

## schematic diagram (each driver)

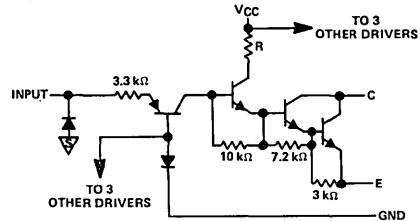

△ = Substrate

UDN2841: R = 15 kΩ each channel

UDN2845: R = 15 kΩ channels 1 and 3, R = 1 kΩ, channels 2 and 4  
Resistor values shown are nominal.

Copyright © 1981 by Texas Instruments Incorporated

TEXAS INSTRUMENTS  
INCORPORATED

POST OFFICE BOX 225012 • DALLAS, TEXAS 75265

# TYPES UDN2841, UDN2845

## QUADRUPLE HIGH-CURRENT DARLINGTON DRIVERS

electrical characteristics at 25°C free-air temperature (unless otherwise noted),  $V_{CC} = 5\text{ V}$ , see figures 1 and 2

PARAMETER	TEST CONDITIONS	UDN2841		UDN2845		UNIT
		MIN	TYP† MAX	MIN	TYP† MAX	
$V_{CEX(sus)}$	Collector sustaining voltage $V_{EE} = -50\text{ V}$ , $V_I = 0.4\text{ V}$ , $I_O = 100\text{ mA}$	35	50	35	50	V
$I_{CEX}$	Collector output cutoff current $V_{EE} = -50\text{ V}$ , $V_I = 0.4\text{ V}$ $V_{EE} = -50\text{ V}$ , $V_I = 0.4\text{ V}$ , $T_A = 70^\circ\text{C}$		100 500		100 500	$\mu\text{A}$
$I_{I(on)}$	On-state input current $I_O = 0.5\text{ A}$		300 500	300	500	$\mu\text{A}$
$V_{I(on)}$	On-state input voltage $I_O = 1.5\text{ A}$ , See Note 3		2.4		2.4	V
$V_{CE(sat)}$	Collector-emitter saturation voltage $V_I = 2.4\text{ V}$ , See Note 3		$I_O = 0.5\text{ A}$ : 1 $I_O = 1\text{ A}$ : 1.25 $I_O = 1.5\text{ A}$ : 1.6		1 1.25 1.6	V
$I_{CC}$	Supply current (each driver) $I_O = 0.5\text{ A}$ , See Note 3		2.5 3.75	2.5	3.75	$\text{mA}$
			2.5 3.75	3.75	7.5	

NOTE 3: These parameters must be measured on one output at a time using pulse techniques,  $t_{pw} = 10\text{ ms}$ , duty cycle  $\leq 10\%$ .

### PARAMETER MEASUREMENT INFORMATION

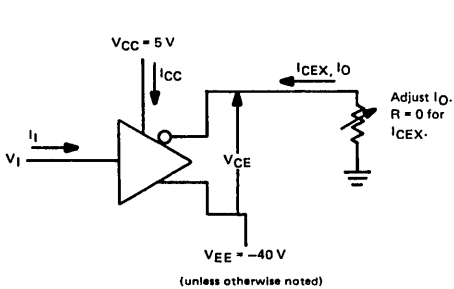

TEST CIRCUIT

NOTE: UDN2841 driver channels 1 through 4 and UDN2845 driver channels 1 and 3 only.

FIGURE 1 – SINK-CURRENT DRIVER

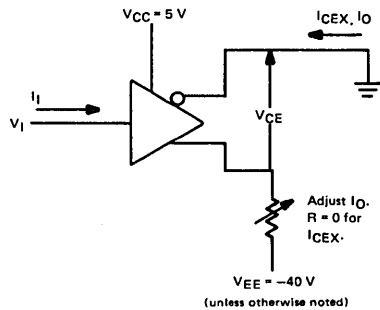

TEST CIRCUIT

NOTE: UDN2845 driver channels 2 and 4 only

FIGURE 2 – SOURCE-CURRENT DRIVER

### THERMAL INFORMATION

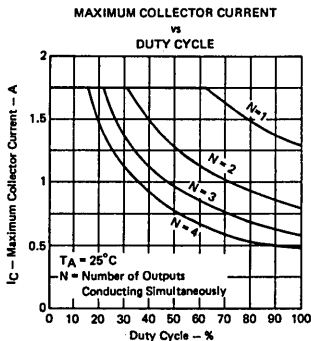

FIGURE 3

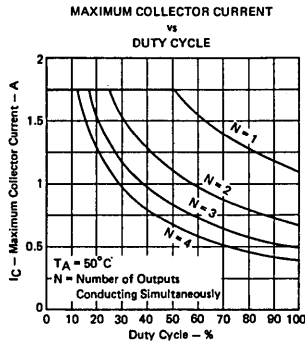

FIGURE 4

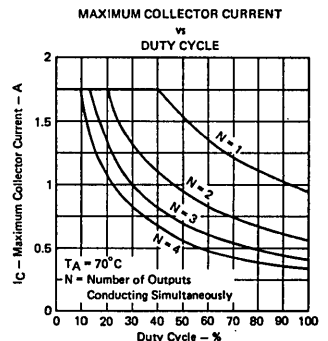

FIGURE 5



# INTERFACE CIRCUITS

# TYPES ULN2001A THRU ULN2005A DARLINGTON TRANSISTOR ARRAYS

BULLETIN NO. DL-S 12467, DECEMBER 1976 - REVISED DECEMBER 1980

## HIGH-VOLTAGE HIGH-CURRENT DARLINGTON TRANSISTOR ARRAYS

- 500 mA Rated Collector Current (Single Output)
- High-Voltage Outputs . . . 50 V
- Output Clamp Diodes
- Inputs Compatible with Various Types of Logic
- Relay Driver Applications
- Designed to be Interchangeable with Sprague ULN2001A Series

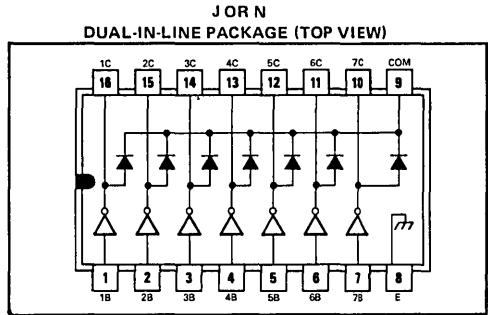

### description

The ULN2001A, ULN2002A, ULN2003A, ULN2004A, and ULN2005A are monolithic high-voltage, high-current darlington transistor arrays. Each comprises seven n-p-n darlington pairs. All units feature high-voltage outputs with common-cathode clamp diodes for switching inductive loads. The collector-current rating of a single darlington pair is 500 milliamperes. Outputs and inputs may each be paralleled for higher current capability. Applications include relay drivers, hammer drivers, lamp drivers, display drivers (LED and gas discharge), line drivers, and logic buffers. For 100-volt (otherwise interchangeable) versions, see the SN75465 through SN75469.

The ULN2001A is a general-purpose array and may be used with DTL, TTL, P-MOS, CMOS, etc. The ULN2002A is specifically designed for use with 14- to 25-volt P-MOS devices and each input has a zener diode and resistor in series to limit the input current to a safe limit. The ULN2003A has a 2.7-k $\Omega$  series base resistor to each darlington pair. This allows operation directly with TTL or 5-volt CMOS. The ULN2004A has an appropriate series input resistor to allow its operation directly from CMOS or P-MOS utilizing supply voltages of 6 to 15 volts. The required input current is below that of the ULN2003A while the required voltage is less than that required by the ULN2002A. The ULN2005A has a 1.05-k $\Omega$  series base resistor and is especially designed for use with TTL where higher output current is required and loading of the driving source is not a concern.

### schematics (each darlington pair)

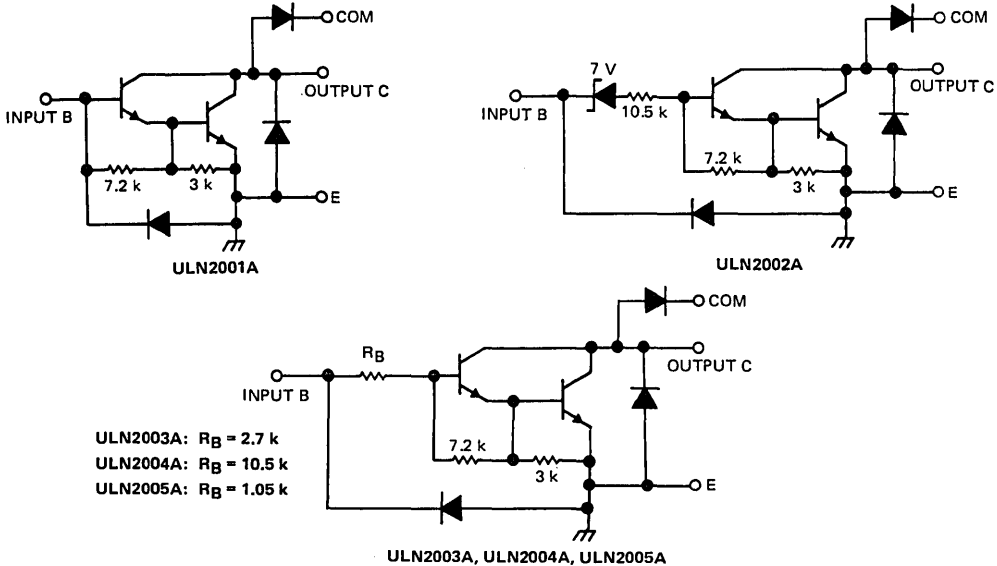

All resistor values shown are nominal and in ohms.

TEXAS INSTRUMENTS  
INCORPORATED

POST OFFICE BOX 225012 • DALLAS, TEXAS 75265

# TYPES ULN2001A THRU ULN2005A DARLINGTON TRANSISTOR ARRAYS

absolute maximum ratings at 25°C free-air temperature (unless otherwise noted)

Collector-emitter voltage	50 V
Input voltage (see Note 1): ULN2002A, ULN2003A, ULN2004A	30 V
ULN2005A	15 V
Peak collector current (see Figures 14 and 15)	500 mA
Continuous input current, ULN2001A only	25 mA
Total substrate-terminal current: J package	-500 mA
N package	-2.5 A
Continuous dissipation (total package) at (or below)	
25°C free-air temperature (see Note 2): J package	1025 mW
N package	1150 mW
Operating free-air temperature range	0°C to 70°C
Storage temperature range	-65°C to 150°C
Lead temperature 1/16 inch (1,6 mm) from case for 60 seconds, J package	300°C
Lead temperature 1/16 inch (1,6 mm) from case for 10 seconds, N package	260°C

- NOTES: 1. All voltage values, unless otherwise noted, are with respect to the emitter/substrate terminal, E.  
2. For operation above 25°C free-air temperature, refer to the Dissipation Derating Curves in the Thermal Information section, which starts on page 2-1. In the J package, ULN2001A through ULN2005A chips are glass-mounted.

electrical characteristics at 25°C free-air temperature (unless otherwise noted)

PARAMETER	TEST FIGURE	TEST CONDITIONS	ULN2001A			ULN2002A			UNIT
			MIN	TYP	MAX	MIN	TYP	MAX	
$I_{CEX}$ Collector cutoff current	1	$V_{CE} = 50 \text{ V}, I_I = 0$	50			50			$\mu\text{A}$
		$V_{CE} = 50 \text{ V}, I_I = 0$	100			100			
$I_{I(off)}$ Off-state input current	3	$T_A = 70^\circ\text{C}, I_C = 500 \mu\text{A}, V_I = 6 \text{ V}$	50 65			50 65			$\mu\text{A}$
		$V_{CE} = 50 \text{ V}, T_A = 70^\circ\text{C}$							
$I_I$ Input current	4	$V_I = 17 \text{ V}$				0.82 1.25			$\text{mA}$
$h_{FE}$ Static forward current transfer ratio	5	$V_{CE} = 2 \text{ V}, I_C = 350 \text{ mA}$	1000						
$V_{I(on)}$ On-state input voltage	6	$V_{CE} = 2 \text{ V}, I_C = 300 \text{ mA}$				13			$\text{V}$
$V_{CE(sat)}$ Collector-emitter saturation voltage	5	$I_I = 250 \mu\text{A}, I_C = 100 \text{ mA}$	0.9 1.1		0.9 1.1				$\text{V}$
		$I_I = 350 \mu\text{A}, I_C = 200 \text{ mA}$	1.0 1.3		1.0 1.3				
		$I_I = 500 \mu\text{A}, I_C = 350 \text{ mA}$	1.2 1.6		1.2 1.6				
$I_R$ Clamp diode reverse current	7	$V_R = 50 \text{ V}$	50			50			$\mu\text{A}$
		$V_R = 50 \text{ V}, T_A = 70^\circ\text{C}$	100			100			
$V_F$ Clamp diode forward voltage	8	$I_F = 350 \text{ mA}$	1.7 2		1.7 2				$\text{V}$
$C_i$ Input capacitance		$V_I = 0 \text{ V}, f = 1 \text{ MHz}$	15 25		15 25				$\text{pF}$

## TYPES ULN2001A THRU ULN2005A DARLINGTON TRANSISTOR ARRAYS

electrical characteristics at 25°C free-air temperature (unless otherwise noted)

PARAMETER	TEST FIGURE	TEST CONDITIONS	ULN2003A			ULN2004A			UNIT	
			MIN	TYP	MAX	MIN	TYP	MAX		
I <sub>CEX</sub> Collector cutoff current	1	V <sub>CE</sub> = 50 V, I <sub>I</sub> = 0	50			50			μA	
		V <sub>CE</sub> = 50 V, I <sub>I</sub> = 0, T <sub>A</sub> = 70°C	100			100				
I <sub>I(off)</sub> Off-state input current	2	T <sub>A</sub> = 70°C, V <sub>I</sub> = 1 V				500				
I <sub>I(off)</sub> Off-state input current	3	V <sub>CE</sub> = 50 V, I <sub>C</sub> = 500 μA, T <sub>A</sub> = 70°C	50	65		50	65		μA	
		V <sub>I</sub> = 3.85 V	0.93	1.35						
I <sub>I</sub> Input current	4	V <sub>I</sub> = 5 V				0.35	0.5		mA	
		V <sub>I</sub> = 12 V				1.0	1.45			
V <sub>I(on)</sub> On-state input voltage	6	V <sub>CE</sub> = 2 V	I <sub>C</sub> = 125 mA				5			V
			I <sub>C</sub> = 200 mA				2.4			
			I <sub>C</sub> = 250 mA				2.7			
			I <sub>C</sub> = 275 mA				7			
			I <sub>C</sub> = 300 mA				3			
I <sub>C</sub> = 350 mA				8						
V <sub>CE(sat)</sub> Collector-emitter saturation voltage	5	I <sub>I</sub> = 250 μA, I <sub>C</sub> = 100 mA	0.9	1.1		0.9	1.1			
		I <sub>I</sub> = 350 μA, I <sub>C</sub> = 200 mA	1.0	1.3		1.0	1.3			
		I <sub>I</sub> = 500 μA, I <sub>C</sub> = 350 mA	1.2	1.6		1.2	1.6			
I <sub>R</sub> Clamp diode reverse current	7	V <sub>R</sub> = 50 V, T <sub>A</sub> = 70°C	50			50			μA	
		V <sub>R</sub> = 50 V, T <sub>A</sub> = 70°C	100			100				
V <sub>F</sub> Clamp diode forward voltage	8	I <sub>F</sub> = 305 mA	1.7	2		1.7	2		V	
C <sub>i</sub> Input capacitance		V <sub>I</sub> = 0 V, f = 1 MHz	15	25		15	25		pF	

electrical characteristics at 25°C free-air temperature (unless otherwise noted)

PARAMETER	TEST FIGURE	TEST CONDITIONS	ULN2005A			UNIT	
			MIN	TYP	MAX		
I <sub>CEX</sub> Collector cutoff current	1	V <sub>CE</sub> = 50 V, I <sub>I</sub> = 0	50			μA	
		V <sub>CE</sub> = 50 V, I <sub>I</sub> = 0, T <sub>A</sub> = 70°C	100				
I <sub>I(off)</sub> Off-state input current	3	V <sub>CE</sub> = 50 V, I <sub>C</sub> = 500 μA, T <sub>A</sub> = 70°C	50	65		μA	
I <sub>I</sub> Input current	4	V <sub>I</sub> = 3 V	1.5			2.4	mA
V <sub>I(on)</sub> On-state input voltage	6	V <sub>CE</sub> = 2 V, I <sub>C</sub> = 350 mA				2.4	V
V <sub>CE(sat)</sub> Collector-emitter saturation voltage	5	I <sub>I</sub> = 250 μA, I <sub>C</sub> = 100 mA	0.9			1.1	V
		I <sub>I</sub> = 350 μA, I <sub>C</sub> = 200 mA	1.0			1.3	
		I <sub>I</sub> = 500 μA, I <sub>C</sub> = 350 mA	1.2			1.6	
I <sub>R</sub> Clamp diode reverse current	7	V <sub>R</sub> = 50 V	50			μA	
		V <sub>R</sub> = 50 V, T <sub>A</sub> = 70°C	100				
V <sub>F</sub> Clamp diode forward voltage	8	I <sub>F</sub> = 350 mA	1.7			2	V
C <sub>i</sub> Input capacitance		V <sub>I</sub> = 0 V, f = 1 MHz	15			25	pF

switching characteristics at 25°C free-air temperature

PARAMETER	TEST CONDITIONS	MIN	TYP	MAX	UNIT	
t <sub>PLH</sub> Propagation delay time, low-to-high-level output	See Figure 9	0.25			1	μs
t <sub>PHL</sub> Propagation delay time, high-to-low-level output		0.25			1	μs
V <sub>OH</sub> High-level output voltage after switching	V <sub>S</sub> = 50 V, I <sub>O</sub> ≈ 300 mA, See Figure 10	V <sub>S</sub> -20				mV

**TEXAS INSTRUMENTS**  
INCORPORATED

POST OFFICE BOX 225012 • DALLAS, TEXAS 75265

# TYPES ULN2001A THRU ULN2005A DARLINGTON TRANSISTOR ARRAYS

## PARAMETER MEASUREMENT INFORMATION

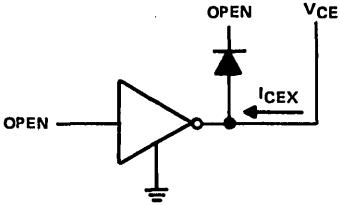

FIGURE 1- $I_{CEX}$

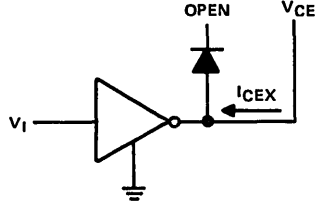

FIGURE 2- $I_{CEX}$

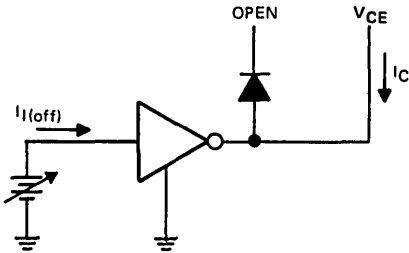

FIGURE 3- $I_{I(off)}$

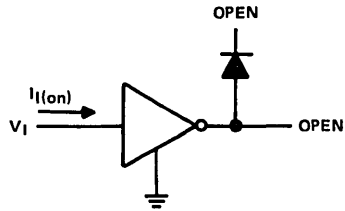

FIGURE 4- $I_I$

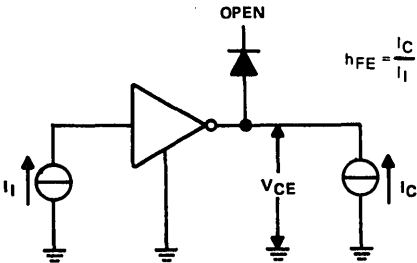

FIGURE 5- $h_{FE}$ ,  $V_{CE(sat)}$

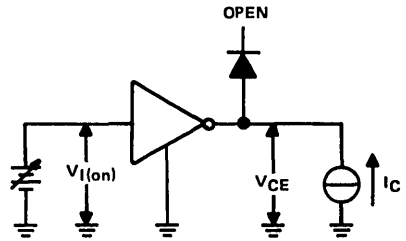

FIGURE 6- $V_{I(on)}$

NOTE:  $I_I$  is fixed for measuring  $V_{CE(sat)}$ , variable for measuring  $h_{FE}$ .

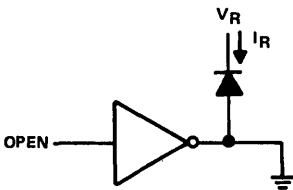

FIGURE 7- $I_R$

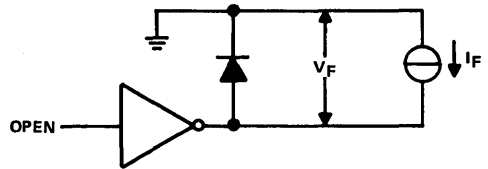
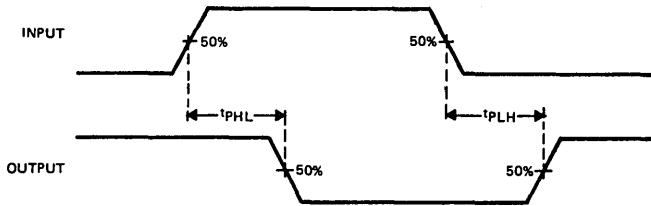

FIGURE 8- $V_F$

# TYPES ULN2001A THRU ULN2005A DARLINGTON TRANSISTOR ARRAYS

## PARAMETER MEASUREMENT INFORMATION



VOLTAGE WAVEFORMS

FIGURE 9—PROPAGATION DELAY TIMES

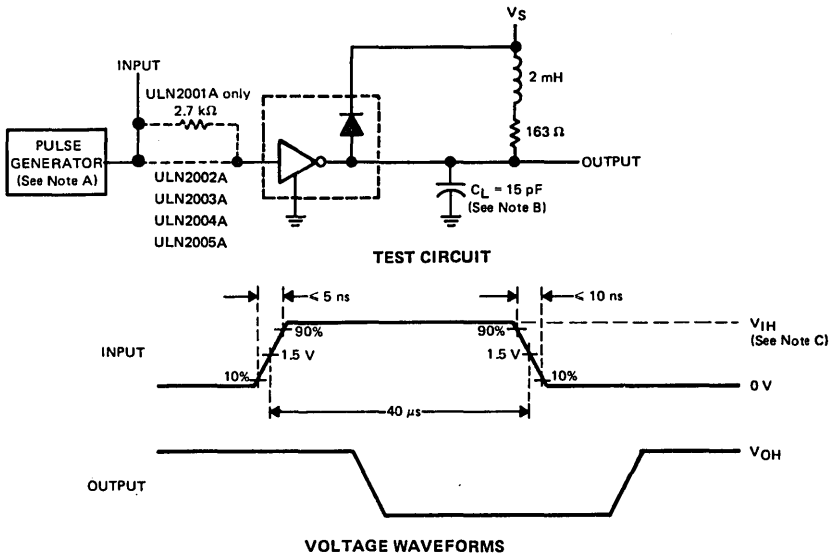

VOLTAGE WAVEFORMS

- NOTES: A. The pulse generator has the following characteristics: PRR = 12.5 kHz,  $Z_{out} = 50 \Omega$ .  
 B.  $C_L$  includes probe and jig capacitance.  
 C. For testing the ULN2001A, ULN2003A and the ULN2005A,  $V_{IH} = 3 \text{ V}$ ; for the ULN2002A,  $V_{IH} = 13 \text{ V}$ ; for the ULN2004A,  $V_{IH} = 8 \text{ V}$ .

FIGURE 10—LATCH-UP TEST

# TYPES ULN2001A THRU ULN2005A DARLINGTON TRANSISTOR ARRAYS

## TYPICAL CHARACTERISTICS

COLLECTOR-EMITTER  
SATURATION VOLTAGE  
VS  
COLLECTOR CURRENT  
(ONE DARLINGTON)

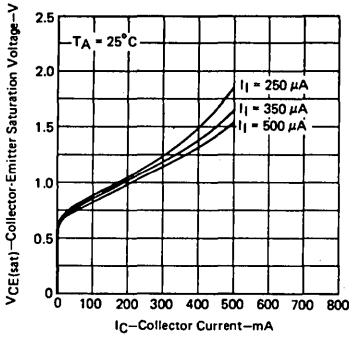

FIGURE 11

COLLECTOR-EMITTER  
SATURATION VOLTAGE  
VS  
COLLECTOR CURRENT  
(TWO DARLINGTONS PARALLELED)

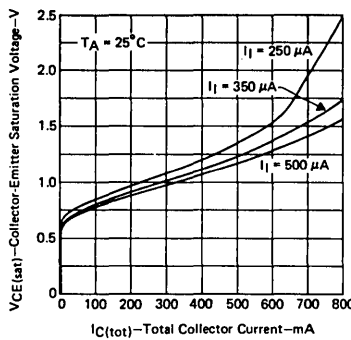

FIGURE 12

COLLECTOR CURRENT  
VS  
INPUT CURRENT

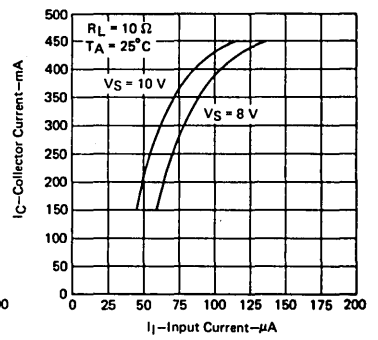

FIGURE 13

## THERMAL INFORMATION

J PACKAGE  
MAXIMUM COLLECTOR CURRENT  
VS  
DUTY CYCLE

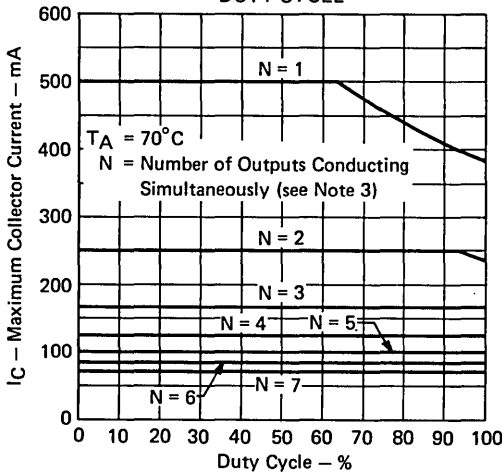

FIGURE 14

N PACKAGE  
MAXIMUM COLLECTOR CURRENT  
VS  
DUTY CYCLE

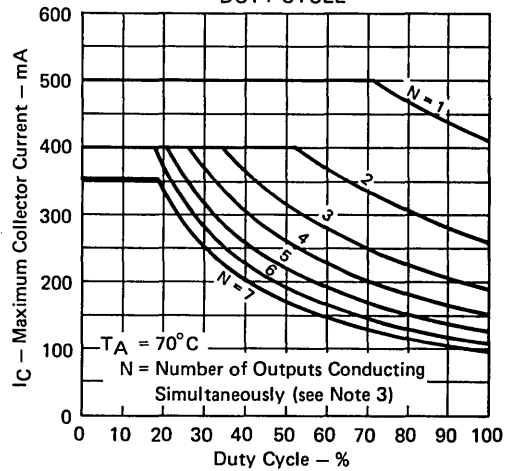
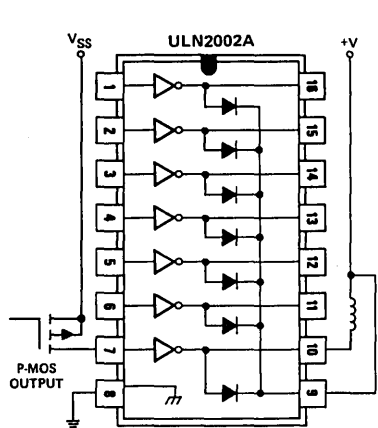

FIGURE 15

NOTE 3: For the J package,  $N \times I_C$  must not exceed 500 mA (maximum substrate-terminal current). For the N package  $N \times I_C$  must not exceed 2.5 A.

# TYPES ULN2001A THRU ULN2005A DARLINGTON TRANSISTOR ARRAYS

## TYPICAL APPLICATION DATA



P-MOS TO LOAD

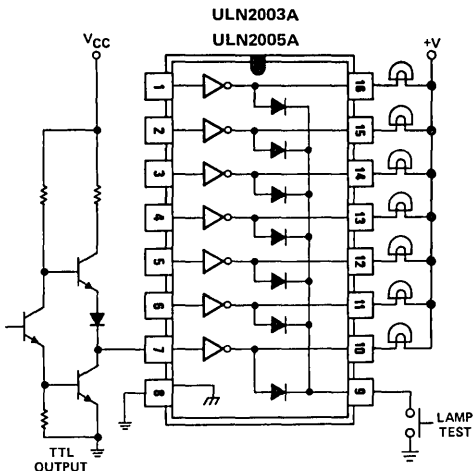

TTL TO LOAD

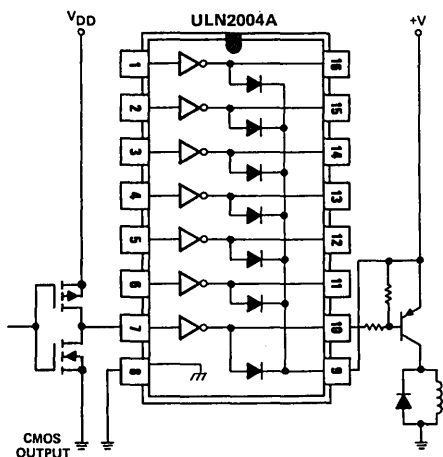

BUFFER FOR  
HIGHER CURRENT LOADS

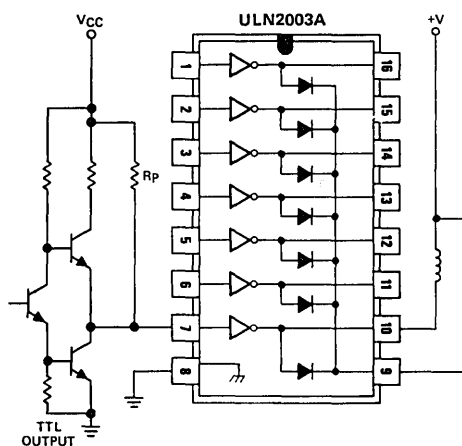

USE OF PULL-UP RESISTORS  
TO INCREASE DRIVE CURRENT

4





# INTERFACE CIRCUITS

# TYPES ULN2064, ULN2065, ULN2066, ULN2067 QUADRUPLE HIGH-CURRENT DARLINGTON SWITCHES

BULLETIN NO. DL-S 12681, DECEMBER 1979 - REVISED FEBRUARY 1981

- Output Collector Current . . . 1.5 A Max
- 2-W Dissipation Rating
- High Output-Voltage Capability
- Outputs Diode-Clamped for Inductive Loads
- Common-Emitter Circuit for Current Sink
- ULN2064 and ULN2065 Have TTL- and DTL-Compatible Inputs
- ULN2066 and ULN2067 Have CMOS- and PMOS-Compatible Inputs
- Designed for Interchangeability with Sprague ULN2064 thru ULN2067, Respectively

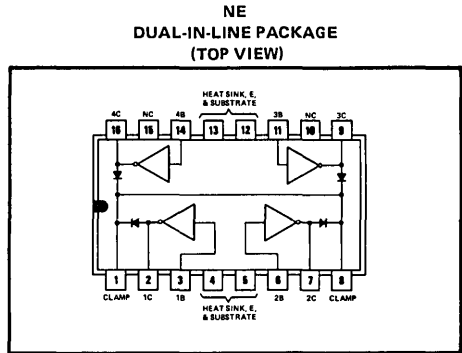

## description

The ULN2064, ULN2065, ULN2066, and ULN2067 are monolithic high-voltage, high-current darlington transistor switches. Each comprises four n-p-n darlington pairs. All units feature high-voltage outputs with common-cathode clamp diodes for switching inductive loads. Outputs and inputs may each be paralleled for higher current capability. Applications include relay drivers, hammer drivers, lamp drivers, display drivers (LED and gas discharge), line drivers, and logic buffers. These common-emitter circuits are designed to operate as current sinks to the load.

The ULN2064 and ULN2065 are intended for use with TTL, DTL, and 5-volt MOS logic. The ULN2066 and ULN2067 are intended for use with PMOS and higher voltage CMOS logic. The ULN2064, ULN2065, ULN2066, and ULN2067 are characterized for operations from 0°C to 70°C.

## schematic (each darlington pair)

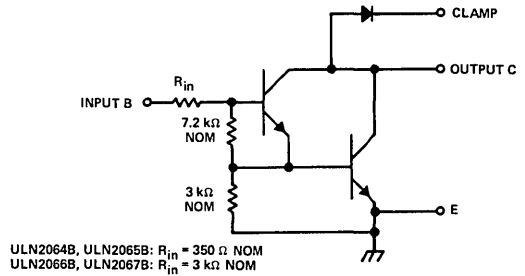

## absolute maximum ratings at 25°C free-air temperature for each switch (unless otherwise noted)

	ULN2064	ULN2065	ULN2066	ULN2067	UNIT
Collector-emitter voltage	50	80	50	80	V
Input voltage (see Note 1)	15	15	30	30	V
Peak collector current (see Figures 12, 13, and 14)	1.5	1.5	1.5	1.5	A
Input current	25	25	25	25	mA
Total power dissipation at (or below) 25°C free-air temperature (see Note 2)	2075	2075	2075	2075	mW
Operating free-air temperature range	0 to 70	0 to 70	0 to 70	0 to 70	°C
Storage temperature range	-55 to 150	-55 to 150	-55 to 150	-55 to 150	°C
Lead temperature 1/16 inch (1,6 mm) from the case for 10 seconds	260	260	260	260	°C

- NOTES: 1. All voltage values (unless otherwise noted) are with respect to the emitter/substrate terminal E.  
2. For operation above 25°C free-air temperature, derate total power to 1328 mW at 70°C at the rate of 16.6 mW/°C.

Copyright © 1981 by Texas Instruments Incorporated

TEXAS INSTRUMENTS  
INCORPORATED

POST OFFICE BOX 225012 • DALLAS, TEXAS 75265

# TYPES ULN2064, ULN2065, ULN2066, ULN2067

## QUADRUPLE HIGH-CURRENT DARLINGTON SWITCHES

electrical characteristics at 25°C free-air temperature (unless otherwise noted)

PARAMETER	TEST FIGURE	TEST CONDITIONS	ULN2064		ULN2065		ULN2066		ULN2067		UNIT	
			MIN	MAX	MIN	MAX	MIN	MAX	MIN	MAX		
$V_{CEX(sus)}$ Collector sustaining voltage	1	$V_I = 0.4\text{ V}$ , $I_C = 100\text{ mA}$	35		50		35		50		V	
$I_{CEX}$ Collector output cutoff current	2	$V_{CE} = 50\text{ V}$	100				100				$\mu\text{A}$	
		$V_{CE} = 50\text{ V}$ , $T_A = 70^\circ\text{C}$	500				500					
		$V_{CE} = 80\text{ V}$			100					100		
		$V_{CE} = 80\text{ V}$ , $T_A = 70^\circ\text{C}$			500					500		
$I_{I(on)}$ On-state input current	3	$V_I = 2.4\text{ V}$	2	4.3	2	4.3					$\text{mA}$	
		$V_I = 3.75\text{ V}$	4.5	9.6	4.5	9.6						
		$V_I = 5\text{ V}$					0.9	1.8	0.9	1.8		
		$V_I = 12\text{ V}$					2.75	5.2	2.75	5.2		
$V_{I(on)}$ On-state input voltage	4	$V_{CE} = 2\text{ V}$ , $I_C = 1\text{ A}$	2		2		6.5		6.5		V	
		$V_{CE} = 2\text{ V}$ , $I_C = 1.5\text{ A}$ , See Note 3	2.5		2.5		10		10			
$V_{CE(sat)}$ Collector-emitter saturation voltage	5	$I_I = 625\text{ }\mu\text{A}$ , $I_C = 500\text{ mA}$	1.1		1.1		1.1		1.1		V	
		$I_I = 935\text{ }\mu\text{A}$ , $I_C = 750\text{ mA}$	1.2		1.2		1.2		1.2			
		$I_I = 1.25\text{ mA}$ , $I_C = 1\text{ A}$	1.3		1.3		1.3		1.3			
		$I_I = 2\text{ mA}$ , $I_C = 1.25\text{ A}$ , See Note 3	1.4				1.4					
		$I_I = 2.25\text{ mA}$ , $I_C = 1.5\text{ A}$ , See Note 3			1.5				1.5			
$I_R$ Clamp-diode reverse current	6	$V_R = 50\text{ V}$	50				50				$\mu\text{A}$	
		$V_R = 50\text{ V}$ , $T_A = 70^\circ\text{C}$	100				100					
		$V_R = 80\text{ V}$			50				50			
		$V_R = 80\text{ V}$ , $T_A = 70^\circ\text{C}$			100				100			
$V_F$ Clamp-diode forward voltage	7	$I_F = 1\text{ A}$	1.75		1.75		1.75		1.75		V	
		$I_F = 1.5\text{ A}$ , See Note 3	2		2		2		2			

NOTE 3: These parameters must be measured on one output at a time using pulse techniques.  $t_w = 10\text{ ms}$ , duty cycle  $\leq 10\%$ .

switching characteristics at 25°C free-air temperature,  $V_{CC} = 5\text{ V}$

PARAMETER	TEST CONDITIONS	MIN	TYP	MAX	UNIT
$t_{PLH}$ Propagation delay time, low-to-high-level output	See Figure 8			1	$\mu\text{s}$
$t_{PHL}$ Propagation delay time, high-to-low-level output				1.5	$\mu\text{s}$

### PARAMETER MEASUREMENT INFORMATION

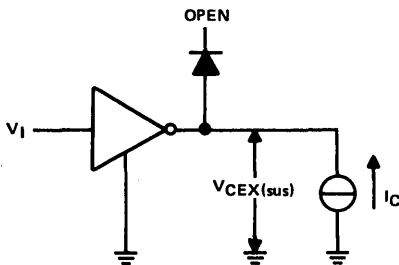

FIGURE 1— $V_{CEX(sus)}$

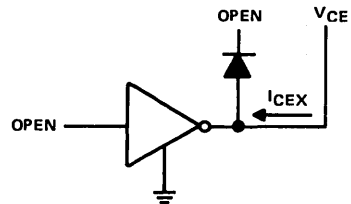

FIGURE 2— $I_{CEX}$

# TYPES ULN2064, ULN2065, ULN2066, ULN2067 QUADRUPLE HIGH-CURRENT DARLINGTON SWITCHES

## PARAMETER MEASUREMENT INFORMATION

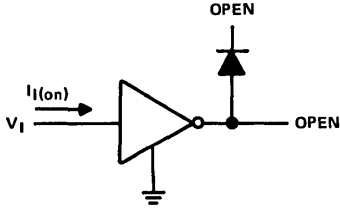

FIGURE 3— $I_{I(on)}$

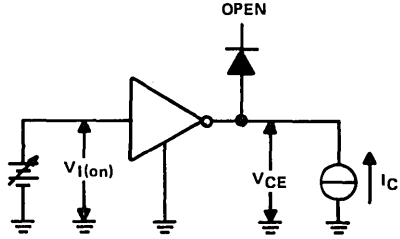

FIGURE 4— $V_{I(on)}$

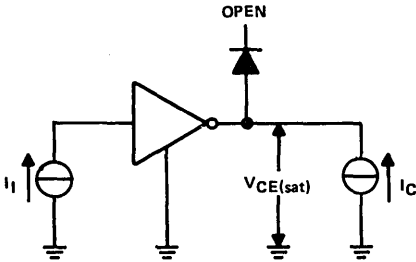

FIGURE 5— $V_{CE(sat)}$

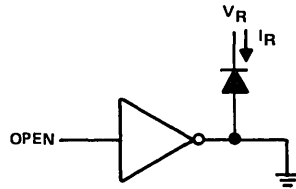

FIGURE 6— $I_R$

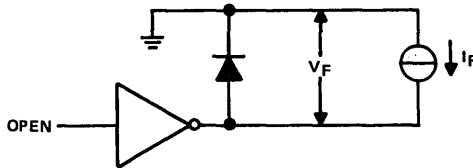
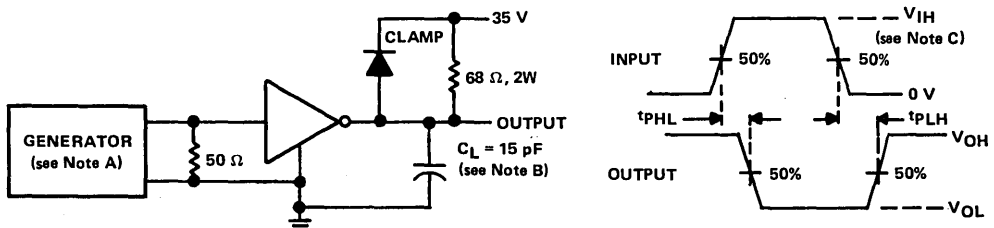

FIGURE 7— $V_F$



NOTES: A. The input pulse is supplied by a generator having the following characteristics: PRR = 50 kHz, duty cycle = 10%,  $Z_0 = 50 \Omega$ .  
B.  $C_L$  includes all probe and stray capacitance.  
C.  $V_{IH} = 2.5$  V for ULN2064 and ULN2065.  $V_{IH} = 10$  V for ULN2066 and ULN2067.

FIGURE 8 — SWITCHING TIMES

TEXAS INSTRUMENTS  
INCORPORATED

POST OFFICE BOX 225012 • DALLAS, TEXAS 75265

# TYPES ULN2064, ULN2065, ULN2066, ULN2067 QUADRUPLE HIGH-CURRENT DARLINGTON SWITCHES

## ELECTRICAL CHARACTERISTICS

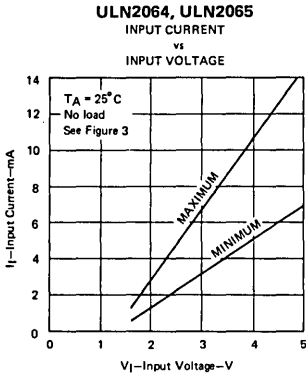

FIGURE 9

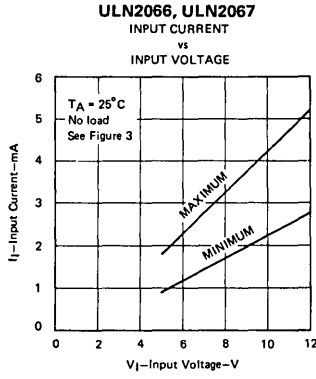

FIGURE 10

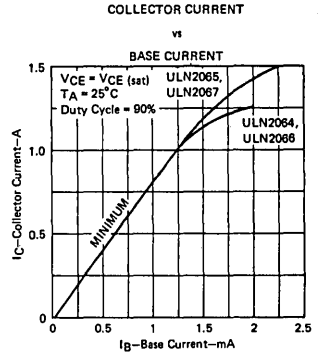

FIGURE 11

## THERMAL INFORMATION

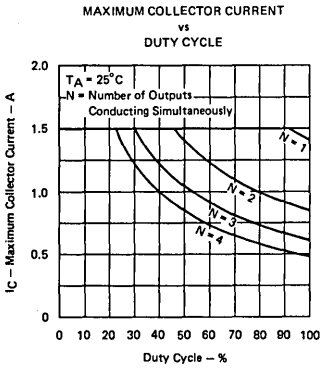

FIGURE 12

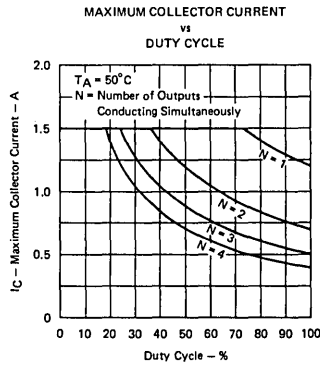

FIGURE 13

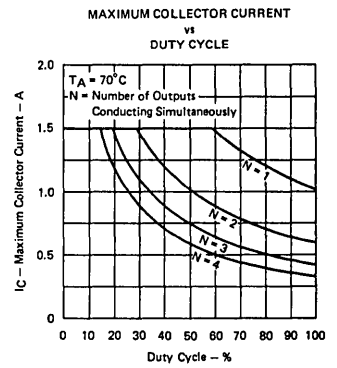

FIGURE 14

## TYPICAL APPLICATION DATA

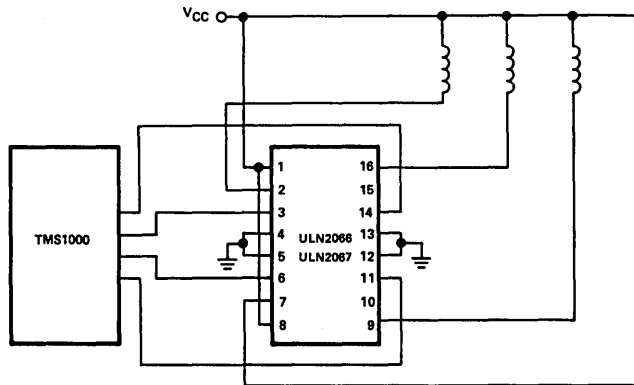

FIGURE 15 - RELAY DRIVER INTERFACE

# INTERFACE CIRCUITS

# TYPES ULN2068, ULN2069 QUADRUPLE HIGH-CURRENT DARLINGTON SWITCHES

BULLETIN NO. DL-S 12751, MAY 1980—REVISED FEBRUARY 1981

- Output Collector Current . . . 1.5 A Max
- 2-W Dissipation Rating
- High Output-Voltage Capability
- Preamp for High Current Gain
- Outputs Diode-Clamped for Inductive Loads
- Common-Emitter Circuit for Current Sink
- Inputs Compatible with TTL and 5-Volt CMOS
- Designed for Interchangeability with Sprague ULN2068 and ULN2069

### description

The ULN2068 and ULN2069 are monolithic integrated circuits each consisting of four high-voltage, high-current n-p-n cascaded transistor switches. Each switch includes a first stage compatible with both TTL and 5-volt CMOS signal levels. The second and third stages form uncommitted-collector outputs with common-cathode clamp diodes for switching inductive loads.

The ULN2068 and ULN2069 can sink up to 1.5 amperes per switch. Applications include logic buffers, MOS drivers, memory drivers, line drivers, relay drivers, hammer drivers, lamp drivers, and display drivers (LED and gas discharge). The ULN2068 and ULN2069 are characterized for operation from 0°C to 70°C.

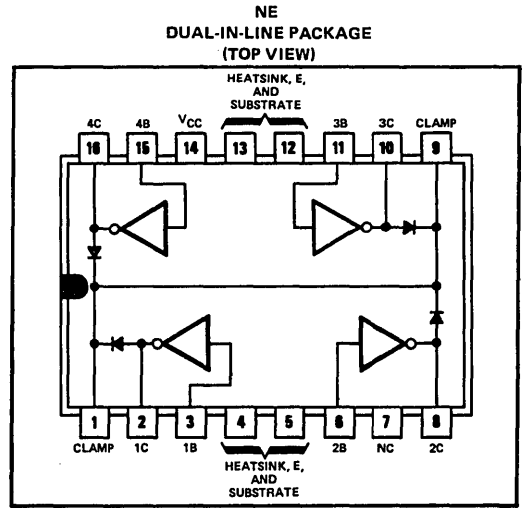

NC—No internal connection

### schematic (each switch)

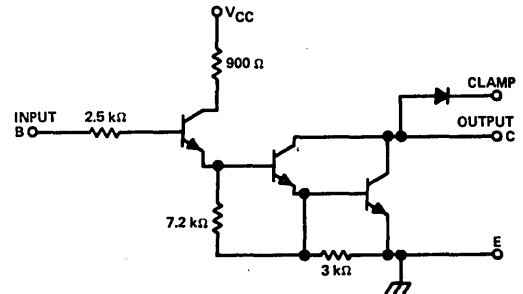

Resistor values shown are nominal.

### absolute maximum ratings at 25°C free-air temperature for each switch (unless otherwise noted)

	ULN2068	ULN2069	UNIT
Collector-emitter voltage	50	80	V
Supply voltage, $V_{CC}$ (see Note 1)	10	10	V
Input voltage	15	15	V
Peak collector current (see Figures 10, 11, and 12)	1.5	1.5	A
Total power dissipation at (or below) 25°C free-air temperature (see Note 2)	2075	2075	mW
Operating free-air temperature range	0 to 70	0 to 70	°C
Storage temperature range	-55 to 150	-55 to 150	°C
Lead temperature 1/16 inch (1.6 mm) from the case for 10 seconds	260	260	°C

- NOTES: 1. All voltage values (unless otherwise noted) are with respect to the emitter/substrate terminal E.  
2. For operation above 25°C free-air temperature, derate total power to 1328 mW at 70°C at the rate of 16.6 mW/°C.

Copyright © 1981 by Texas Instruments Incorporated

TEXAS INSTRUMENTS  
INCORPORATED

POST OFFICE BOX 225012 • DALLAS, TEXAS 75265

# TYPES ULN2068, ULN2069

## QUADRUPLE HIGH-CURRENT DARLINGTON SWITCHES

electrical characteristics at 25°C free-air temperature,  $V_{CC} = 5\text{ V}$  (unless otherwise noted)

PARAMETER	TEST FIGURE	TEST CONDITIONS	ULN2068		ULN2069		UNIT
			MIN	MAX	MIN	MAX	
$V_{CEX(sus)}$ Collector sustaining voltage	1	$V_I = 0.4\text{ V}$ , $I_C = 100\text{ mA}$	35		50		V
$I_{CEX}$ Collector output cutoff current	2	$V_{CE} = 50\text{ V}$		100			$\mu\text{A}$
		$V_{CE} = 50\text{ V}$ , $T_A = 70^\circ\text{C}$		500			
		$V_{CE} = 80\text{ V}$				100	
$I_{I(on)}$ On-state input current	3	$V_I = 2.4\text{ V}$		250		250	$\mu\text{A}$
		$V_I = 3.75\text{ V}$		1000		1000	
$V_{I(on)}$ On-state input voltage	4	$V_{CE} = 2\text{ V}$ , $I_C = 1.5\text{ A}$ , See Note 3		2.4		2.4	V
$V_{CE(sat)}$ Collector-emitter saturation voltage	5	$V_I = 2.4\text{ V}$ , $I_C = 500\text{ mA}$		1.1		1.1	V
		$V_I = 2.4\text{ V}$ , $I_C = 750\text{ mA}$		1.2		1.2	
		$V_I = 2.4\text{ V}$ , $I_C = 1\text{ A}$		1.3		1.3	
		$V_I = 2.4\text{ V}$ , $I_C = 1.25\text{ A}$ , See Note 3		1.4			
		$V_I = 2.4\text{ V}$ , $I_C = 1.5\text{ A}$ , See Note 3					
$I_R$ Clamp-diode reverse current	6	$V_R = 50\text{ V}$		50			$\mu\text{A}$
		$V_R = 50\text{ V}$ , $T_A = 70^\circ\text{C}$		100			
		$V_R = 80\text{ V}$				50	
		$V_R = 80\text{ V}$ , $T_A = 70^\circ\text{C}$				100	
$V_F$ Clamp-diode forward voltage	7	$I_F = 1\text{ A}$		1.75		1.75	V
		$I_F = 1.5\text{ A}$ , See Note 3		2		2	
$I_{CC}$ Supply current (only one switch conducting)	8	$V_I = 2.4\text{ V}$ , $I_C = 500\text{ mA}$		6		6	mA

NOTE 3: These parameters must be measured on one output at a time using pulse techniques.  $t_w = 10\text{ ms}$ , duty cycle  $\leq 10\%$ .

switching characteristics at 25°C free-air temperature,  $V_{CC} = 5\text{ V}$

PARAMETER	TEST CONDITIONS	MIN	TYP	MAX	UNIT
$t_{PLH}$ Propagation delay time, low-to-high-level output	See Figure 9			1	$\mu\text{s}$
$t_{PHL}$ Propagation delay time, high-to-low-level output				1.5	$\mu\text{s}$

### PARAMETER MEASUREMENT INFORMATION

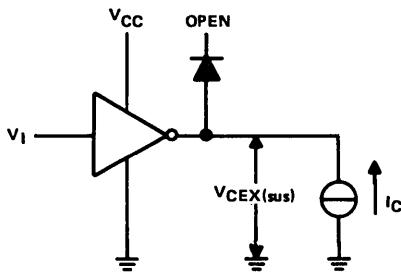

FIGURE 1— $V_{CEX(sus)}$

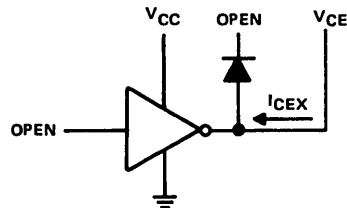

FIGURE 2— $I_{CEX}$

# TYPES ULN2068, ULN2069 QUADRUPLE HIGH-CURRENT DARLINGTON SWITCHES

## PARAMETER MEASUREMENT INFORMATION

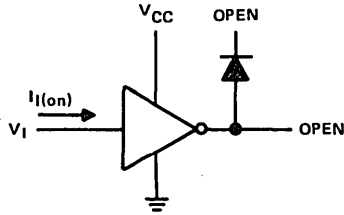

FIGURE 3— $I_{I(on)}$

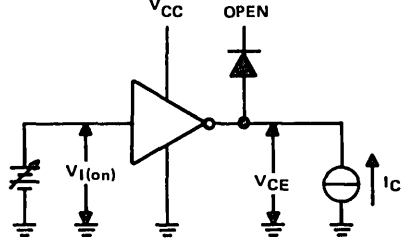

FIGURE 4— $V_{I(on)}$

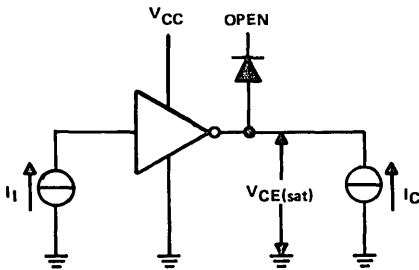

FIGURE 5— $V_{CE(sat)}$

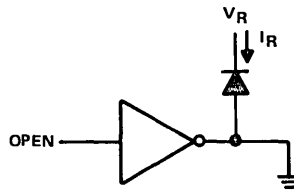

FIGURE 6— $I_R$

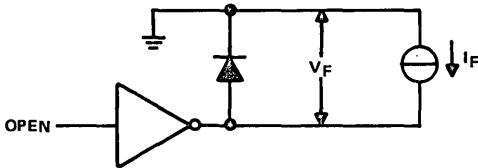

FIGURE 7— $V_F$

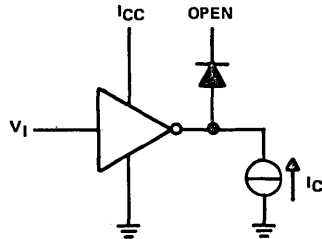
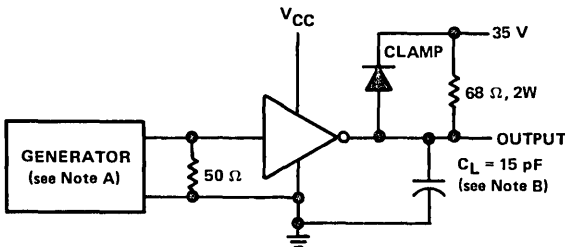
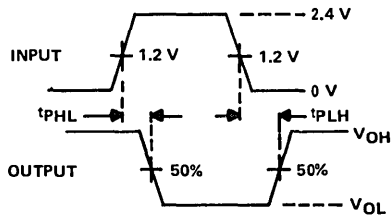

FIGURE 8— $I_{CC}$



TEST CIRCUIT



VOLTAGE WAVEFORMS

NOTES: A. The input pulse is supplied by a generator having the following characteristics: PRR = 50 kHz, duty cycle = 10%,  $Z_0 = 50 \Omega$ .  
B.  $C_L$  includes all probe and stray capacitance.

FIGURE 9—SWITCHING TIMES

# TYPES ULN2068, ULN2069 QUADRUPLE HIGH-CURRENT DARLINGTON SWITCHES

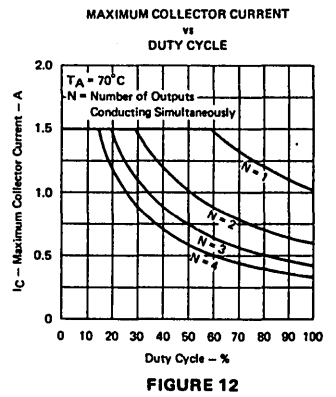
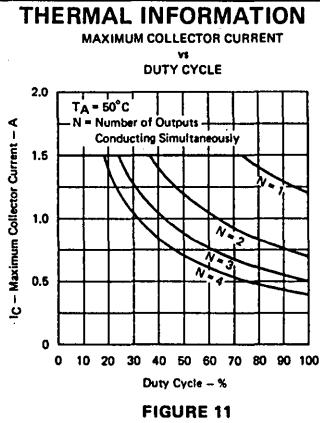
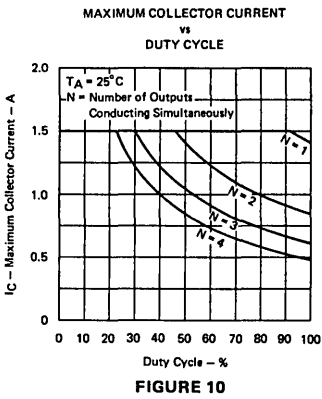

## TYPICAL APPLICATION DATA

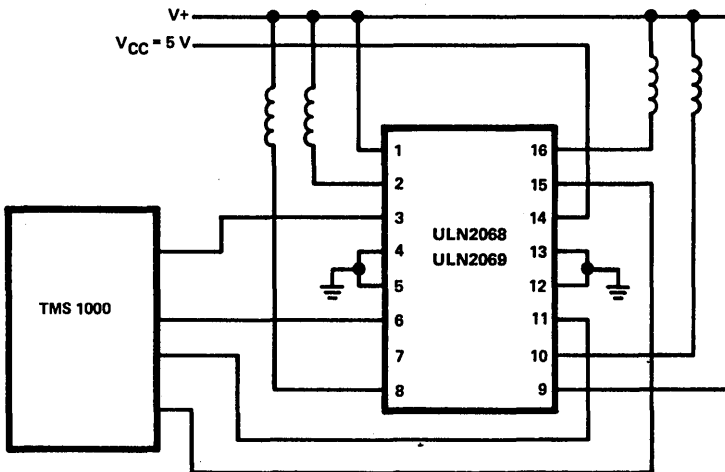

FIGURE 13—RELAY DRIVER INTERFACE



# INTERFACE CIRCUITS

# TYPES ULN2074, ULN2075 QUADRUPLE HIGH-CURRENT DARLINGTON SWITCHES

BULLETIN NO. DL-S 12750, MAY 1980 — REVISED FEBRUARY 1981

- Output Collector Current . . . 1.5 A Max
- 2-W Dissipation Rating
- High Output-Voltage Capability
- Output Sink- or Source-Current Capabilities
- Input Compatible With TTL or 5-V CMOS
- Designed for Interchangeability with Sprague ULN2074 and ULN2075

NE  
DUAL-IN-LINE PACKAGE  
(TOP VIEW)

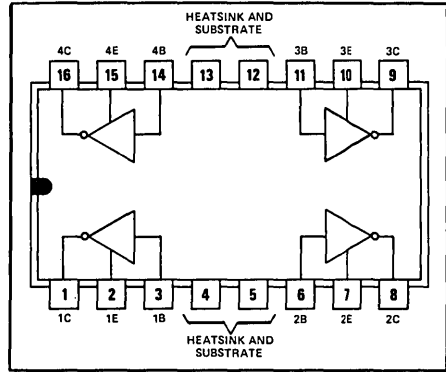

## description

The ULN2074 and ULN2075 are monolithic, quadruple, high-voltage, high-current n-p-n darlington-transistor amplifier devices. They feature high-voltage outputs with collector-current ratings of 1.5 amperes for each darlington pair.

The ULN2074 and ULN2075 are unique general-purpose devices, each featuring uncommitted collectors and emitters to allow for either sinking or sourcing the output current. These devices offer the system designer the flexibility of tailoring the circuit to the application. Typical applications include logic buffers, relay drivers, lamp drivers, and hammer drivers.

For proper operation, the substrate must be connected to the most negative voltage.

The ULN2074 and ULN2075 are characterized for operation from 0°C to 70°C.

## schematic (each switch)

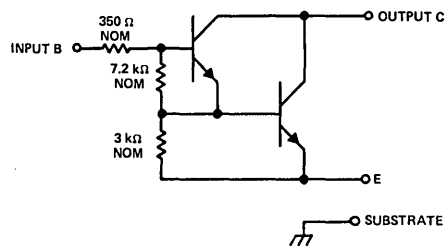

## absolute maximum ratings at 25°C free-air temperature for each switch (unless otherwise noted)

	ULN2074	ULN2075	UNIT
Collector-emitter voltage	50	80	V
Input voltage with respect to substrate	30	60	V
Peak collector current (see Figures 9, 10, and 11)	1.5	1.5	A
Input current	25	25	mA
Total power dissipation at (or below) 25°C free-air temperature (see Note 1)	2075	2075	mW
Operating free-air temperature range	0 to 70	0 to 70	°C
Storage temperature range	-55 to 150	-55 to 150	°C
Lead temperature 1/16 inch (1,6 mm) from the case for 10 seconds	260	260	°C

NOTE 1: For operation above 25°C free-air temperature, derate total power to 1328 mW at 70°C at the rate of 16.6 mW/°C.

Copyright © 1981 by Texas Instruments Incorporated

TEXAS INSTRUMENTS  
INCORPORATED

POST OFFICE BOX 225012 • DALLAS, TEXAS 75265

# TYPES ULN2074, ULN2075 QUADRUPLE HIGH-CURRENT DARLINGTON SWITCHES

electrical characteristics at 25°C free-air temperature (unless otherwise noted)

PARAMETER	TEST FIGURE	TEST CONDITIONS	ULN2074		ULN2075		UNIT
			MIN	MAX	MIN	MAX	
$V_{CE(sus)}$ Collector sustaining voltage	1	$V_I = 0.4 \text{ V}$ , $I_C = 100 \text{ mA}$	35		50		V
$I_{CEX}$ Collector output cutoff current	2	$V_{CE} = 50 \text{ V}$	100				$\mu\text{A}$
		$V_{CE} = 50 \text{ V}$ , $T_A = 70^\circ\text{C}$	500				
		$V_{CE} = 80 \text{ V}$			100		
		$V_{CE} = 80 \text{ V}$ , $T_A = 70^\circ\text{C}$			500		
$I_{I(on)}$ On-state input current	3	$V_I = 2.4 \text{ V}$	2	4.3	2	4.3	mA
		$V_I = 3.75 \text{ V}$	4.5	9.6	4.5	9.6	
$V_{I(on)}$ On-state input voltage	4	$V_{CE} = 2 \text{ V}$ , $I_C = 1 \text{ A}$	2		2		V
		$V_{CE} = 2 \text{ V}$ , $I_C = 1.5 \text{ A}$ , See Note 2	2.5		2.5		
$V_{CE(sat)}$ Collector-emitter saturation voltage	5	$I_I = 625 \mu\text{A}$ , $I_C = 500 \text{ mA}$	1.1		1.1		V
		$I_I = 935 \mu\text{A}$ , $I_C = 750 \text{ mA}$	1.2		1.2		
		$I_I = 1.25 \text{ mA}$ , $I_C = 1 \text{ A}$	1.3		1.3		
		$I_I = 2 \text{ mA}$ , $I_C = 1.25 \text{ A}$ , See Note 2	1.4				
		$I_I = 2.25 \text{ mA}$ , $I_C = 1.5 \text{ A}$ , See Note 2			1.5		

NOTE 2: These parameters must be measured on one output at a time using pulse techniques,  $t_w = 10 \text{ ms}$ , duty cycle  $\leq 10\%$ .

switching characteristics at 25°C free-air temperature

PARAMETER	TEST CONDITIONS	MIN	TYP	MAX	UNIT
$t_{PLH}$ Propagation delay time, low-to-high-level output	See Figure 6			1	$\mu\text{s}$
$t_{PHL}$ Propagation delay time, high-to-low-level output				1.5	$\mu\text{s}$

## PARAMETER MEASUREMENT INFORMATION

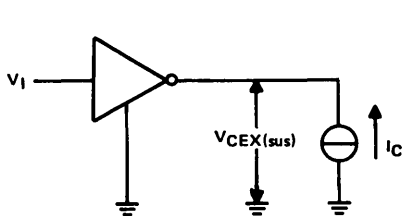

FIGURE 1— $V_{CE(sus)}$

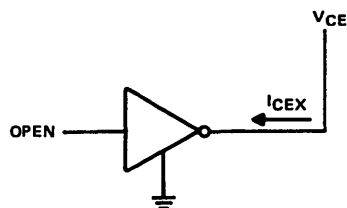

FIGURE 2— $I_{CEX}$

# TYPES ULN2074, ULN2075 QUADRUPLE HIGH-CURRENT DARLINGTON SWITCHES

## PARAMETER MEASUREMENT INFORMATION

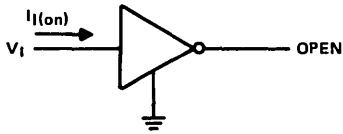

FIGURE 3— $I_{I(on)}$

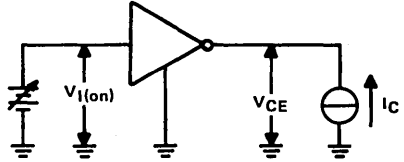

FIGURE 4— $V_{I(on)}$

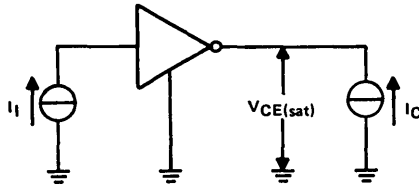
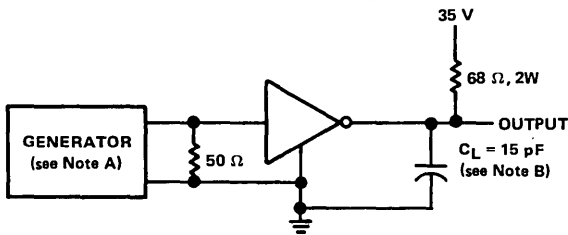
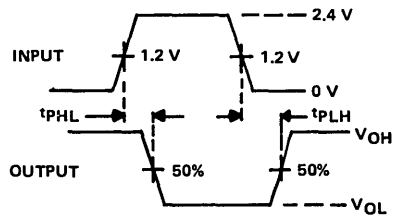

FIGURE 5— $V_{CE(sat)}$



TEST CIRCUITS



VOLTAGE WAVEFORMS

NOTES: A. The input pulse is supplied by a generator having the following characteristics: PRR = 50 kHz, duty cycle = 10%,  $Z_o = 50 \Omega$ .  
B.  $C_L$  includes all probe and stray capacitance.

FIGURE 6—SWITCHING CHARACTERISTIC

# TYPES ULN2074, ULN2075 QUADRUPLE HIGH-CURRENT DARLINGTON SWITCHES

## ELECTRICAL CHARACTERISTICS

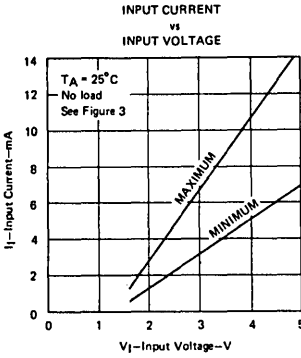

FIGURE 7

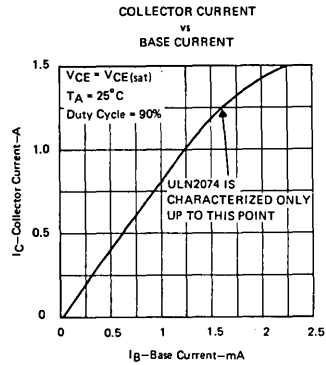

FIGURE 8

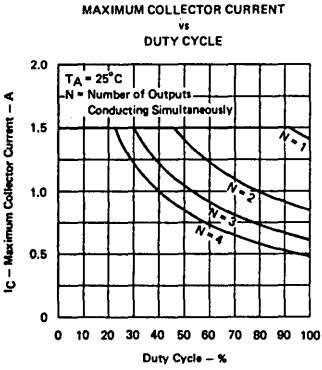

FIGURE 9

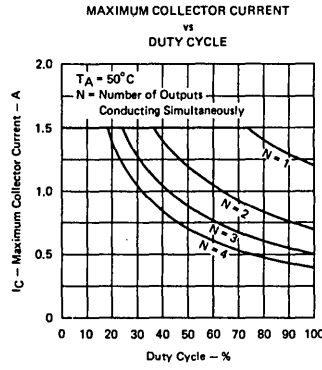

FIGURE 10

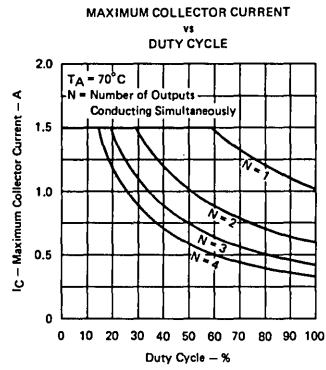

FIGURE 11

## TYPICAL APPLICATION DATA

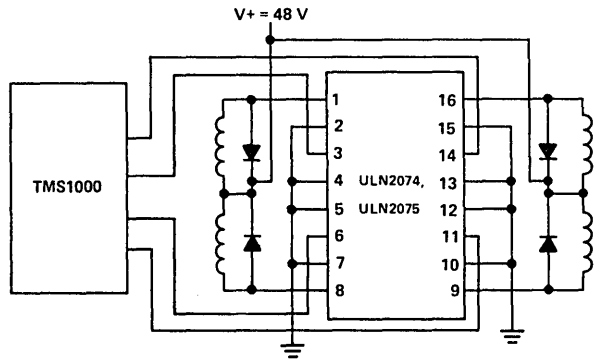

FIGURE 12—RELAY DRIVER INTERFACE WITH EXTERNAL CLAMP DIODES

# TYPICAL APPLICATIONS

## general

The applications have been divided into several categories. Even though a particular device is shown in a given application, that does not mean it is the only device that can be used. For example, the SN75451B is shown as a lamp driver. Depending on the voltage and current requirements, other devices may be used such as the SN75401, SN75411, SN75431, SN75461, SN75471, and so forth.

The categories into which the applications have been divided are as follows:

- Lamp drivers
- Relay/solenoid drivers
- Hammer drivers
- Core memory driver and inhibit control
- Digital comparators
- Detectors
- TTL-to-MOS and MOS-to-TTL drivers
- Inverting buffers for high-current loads
- Miscellaneous applications

## lamp drivers

Figures 1 and 2 show basic lamp driver applications.

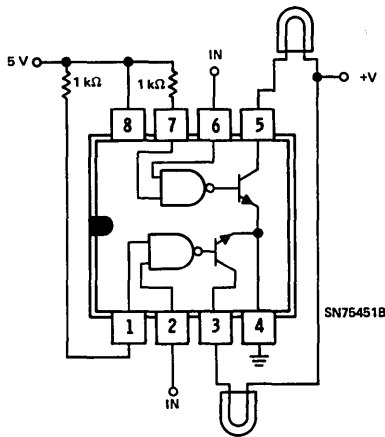

FIGURE 1 – LAMP DRIVER

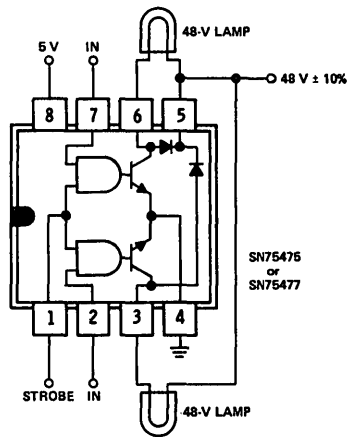

FIGURE 2 – HIGH-VOLTAGE LAMP DRIVER WITH INDUCTIVE CLAMP-DIODE PROTECTION

Note that in any lamp-driver application the turn-on surge current of a cold lamp may be as much as 10 times the normal on current; a 100-mA lamp may have a 1-amp turn-on surge. Peripheral drivers can handle 100-mA operating currents, but a 1-amp surge is far more demanding. The normal maximum continuous collector current rating is 300 or 500 mA, although a 500 or 1000 mA (maximum) surge current may be sustained for duty cycles not to exceed 50% or 40%, respectively, with on time less than 10 milliseconds. Current peaks exceeding these maximums may cause device deterioration.

# TYPICAL APPLICATIONS

## lamp drivers (continued)

Several methods can be employed to limit surge currents when using peripheral drivers. These methods allow 200- to 300-mA lamps to be driven without exceeding the surge limits of the devices. One method that can be used employs "keep alive" resistors as shown in Figure 3. These resistors maintain off-state current at approximately 10%. This will reduce the surge current.

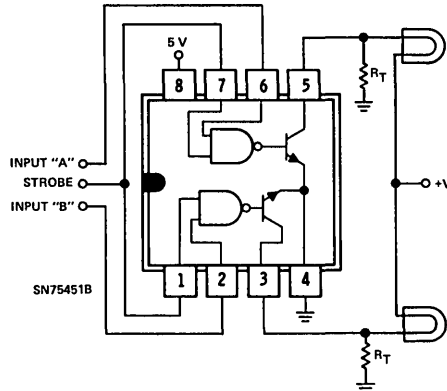

FIGURE 3 – LAMP DRIVERS WITH "KEEP ALIVE" RESISTORS

With the basic SN75450B, SN75460, or SN75470, the availability of the gate output and base leads, as well as the emitter lead, allows use of several methods of current limiting. One method is to place a current-limiting resistor between the gate output and the transistor base, as shown in Figure 4. With an operating load current of 100 mA, a typical  $h_{FE}$  of 50 for the output transistor, and selecting 250 mA as the peak surge, the value of the base resistor can be determined from the following equation:

$$R = \frac{V_{OH} - V_{BE}}{I_B \text{ (limit)}}$$

where:

$$V_{OH} = 3.3 \text{ V (typical)}$$

$$V_{BE} = 0.85 \text{ V (typical)}$$

$$I_B \text{ (limit)} = \frac{I_C \text{ (limit)}}{h_{FE}} = \frac{250 \text{ mA}}{50} = 5 \text{ mA}$$

Therefore:

$$R = \frac{3.3 - 0.85}{0.005} \approx 500 \Omega$$

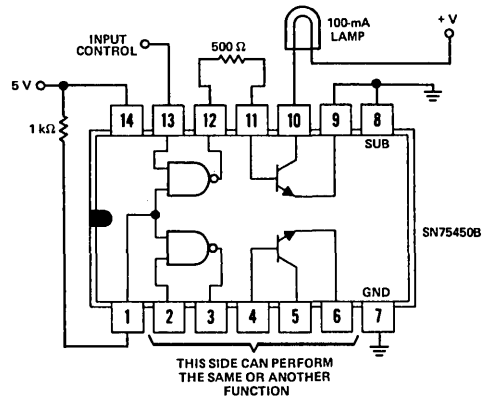

FIGURE 4 – LAMP DRIVER WITH BASE RESISTOR SURGE LIMITING

This method is not the best because of lack of control over critical parameters. A worst-case condition of low  $V_{BE}$ , high  $h_{FE}$ , and high gate output would result in peak surges in excess of 500 mA.

## TYPICAL APPLICATIONS

Figure 5 shows a configuration that is less susceptible to variations in parameters. The emitter resistor is small enough to be of little significance at the steady-state on level, but will limit the peak levels. In this example, a GE1815 lamp was used and the actual steady-state current was 191 mA. With a typical gate  $V_{OH}$  of 3.3 volts and a  $V_{BE}$  of 0.95 volt, (at 200 mA) the transistor will saturate and limit when its emitter voltage reaches  $V_{OH} - V_{BE}$ , or 2.35 volts; this occurs at  $V_E/R_E$ , or about 345 mA. Figure 6 shows the output current waveform.

### lamp drivers (continued)

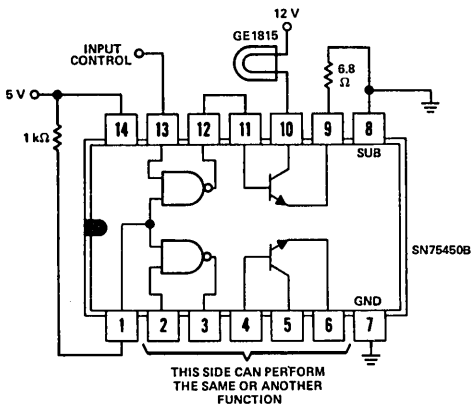

FIGURE 5 – LAMP DRIVER WITH  
EMITTER RESISTOR SURGE LIMITING

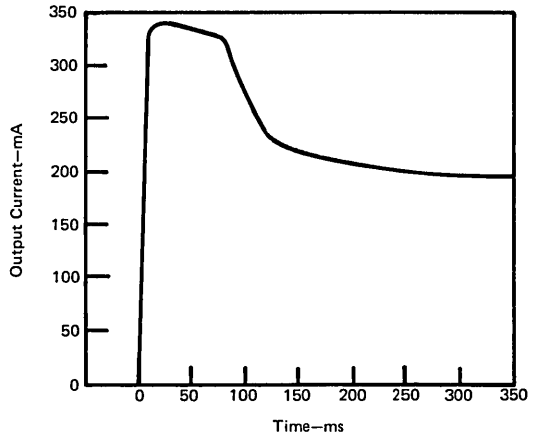

FIGURE 6 – OUTPUT CURRENT vs TIME  
FOR CIRCUIT IN FIGURE 5

In this example the peak surge is sustained for about 150 milliseconds. As the lamp warms, its impedance rises and the load current drops rapidly to the steady-state level. Even with worst-case parameters the surge current would be under 500 mA. The efficient performance of this type of current limiting explains its popularity for lamp-driver applications.

Improved accuracy and consistent performance can be achieved by utilizing one of the output transistors as a current-sensing device to clamp the lamp driver as shown in Figure 7. In this circuit the lamp current must flow through the 1.9-ohm resistor in the emitter of the lamp driver. The first advantage is that the resistor is smaller than that required in the previous circuit, and has even less effect on the steady-state operating level. The base-emitter junction of Q2 is connected across the 1.9-ohm resistor, with its collector tied to the base of Q1 in a typical current-limiting mode. A  $V_{BE}$  of only about 0.6 volt begins to turn Q2 on, clamping the base drive into Q1. Clamping occurs at an output current equal to  $V_{BE}/1.9 \Omega$ , or  $0.6 V/1.9 \Omega$ ; the output clamp level is then 316 mA. As in the previous application, the surge current lasts for about 100 milliseconds before decreasing rapidly to the quiescent level of 190 to 200 mA.

Two important precautions should be kept in mind when using this type of surge protection; (1) surge currents should not be allowed to exceed the driver surge rating under any conditions; and (2) current limiting must not take place during steady-state operations, as this would increase driver power dissipation and could cause failure.

# TYPICAL APPLICATIONS

## lamp drivers (continued)

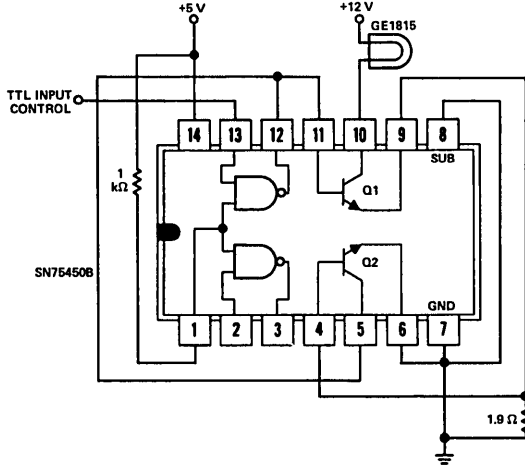

FIGURE 7 – LAMP DRIVER WITH CURRENT-SENSING SURGE PROTECTION

Another method is basically to use two switches; one to turn on the lamp with current limiting and the second to take over, after a delay, without current limiting. This eliminates the effects of parameter variation without reducing the quiescent operating level of the lamp. Such a circuit using the SN75452B is shown in Figure 8. A high-level input turns Q1 on immediately, while Q2 is delayed by the input RC network, allowing about 200 milliseconds of limited-current warm-up before turning the lamp on fully. Figure 9 shows the current levels versus time, and the effect of the warm-up mode on resulting peak levels.

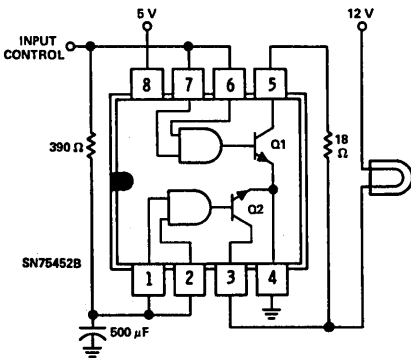

FIGURE 8 – LAMP DRIVER WITH WARM-UP CIRCUIT

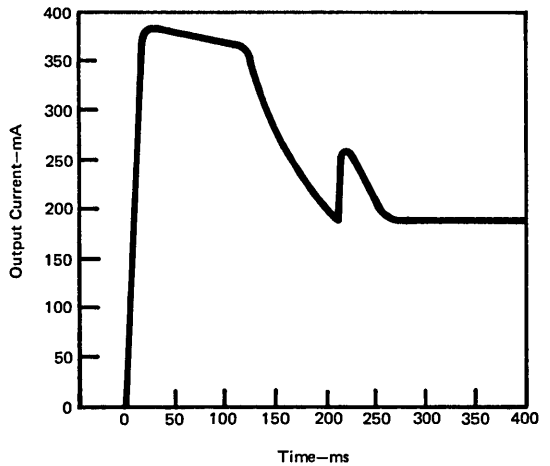

FIGURE 9 – OUTPUT CURRENT vs TIME FOR CIRCUIT IN FIGURE 8



# TYPICAL APPLICATIONS

## lamp drivers (continued)

Another interesting lamp-driver application is depicted in Figure 10, showing the SN75450B as a panel-light intensity control. Controllable feedback around the gate allows its operation in the linear region, thus providing variable drive to the output transistor. An emitter resistor as shown may be used to limit initial turn-on surges. In this application a large amount of power will be dissipated in the output transistor at half-power operating levels.

Care must be taken not to exceed the total power-dissipation capability of the drivers. In a typical application the gate output will be only about 2.2 volts because of operation within the linear region. A control setting of about 280 ohms puts the gate in its linear region. A control setting of 100 to 150 ohms turns off the lamp, and a setting of 700 to 800 ohms will yield a full-on condition.

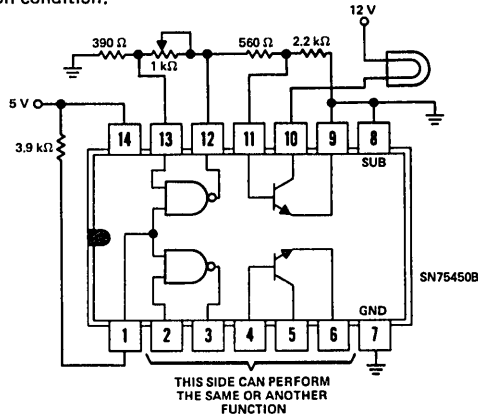

FIGURE 10 – PANEL-LIGHT INTENSITY CONTROL

## relay/solenoid drivers

Figures 11 and 12 show typical relay/solenoid driver applications. Note that when using drivers that do not have output clamp diodes provided internally, these diodes should be provided externally across the inductive load as shown in Figure 12.

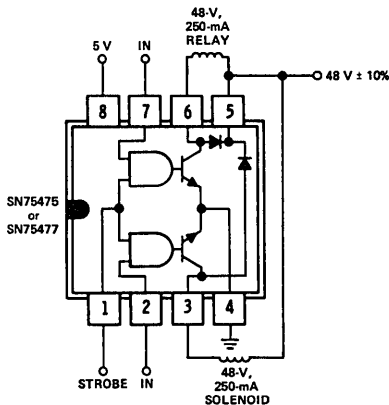

FIGURE 11 – HIGH-VOLTAGE RELAY/SOLENOID DRIVER

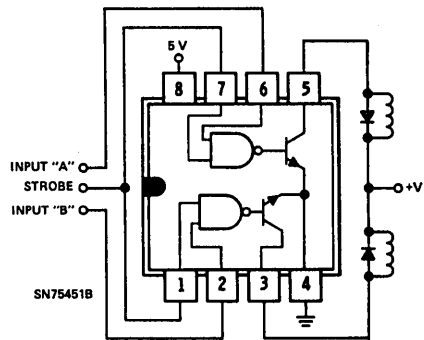

FIGURE 12 – RELAY/SOLENOID DRIVER WITH EXTERNAL CLAMP DIODES

# TYPICAL APPLICATIONS

## relay/solenoid drivers (continued)

In some applications involving the switching of inductive loads, the fast rise time and high-voltage transient occurring during turn-off can force the output transistor into a secondary breakdown condition. In such cases the collector voltage reaches  $V_{CC2}$  levels within a few nanoseconds. To prevent undesired breakdown, the collector-voltage slew rate should be reduced to 1 volt per nanosecond or less. This gives the gate sufficient time to provide a low base-to-ground impedance before the collector voltage is extremely high, and collector-to-emitter breakdown is prevented. To accomplish this, a 500- to 1000-pF capacitor from the collector of the output transistor to ground is usually adequate (see Figure 13).

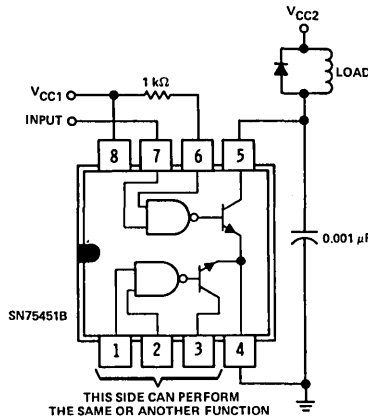

FIGURE 13—CAPACITOR PREVENTS PREMATURE COLLECTOR-TO-EMITTER BREAKDOWN

In some systems, power-supply failure or sequencing may result in the output  $V_{CC2}$  collector supply being on while the gate supply  $V_{CC1}$  is off. Under this condition the collector-to-emitter breakdown is generally lower because of the increase in base-terminating impedance resulting from the gate being off. Figure 14 shows a practical method of preventing complete loss of gate power while  $V_{CC2}$  is on; the zener diode yields a 4- to 5-volt supply level to the gate during  $V_{CC1}$  power failure.

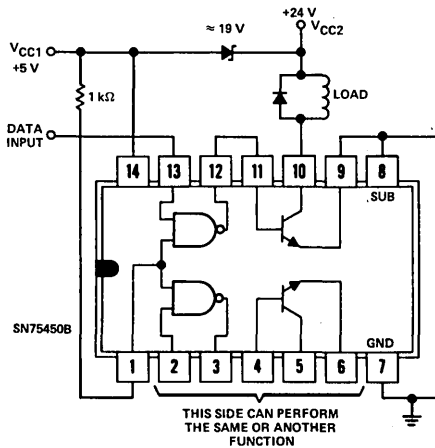

FIGURE 14—PROTECTION AGAINST LOSS OF  $V_{CC1}$

hammer drivers

Figure 15 shows a typical hammer-driver application. If the type of driver used does not have internal output clamp diodes, a 1N3064 or similar diode should be connected across the inductive load in order to provide this protection.

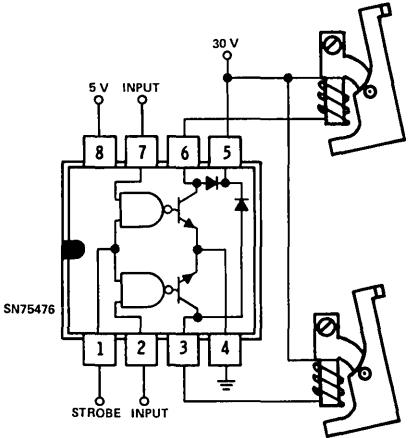
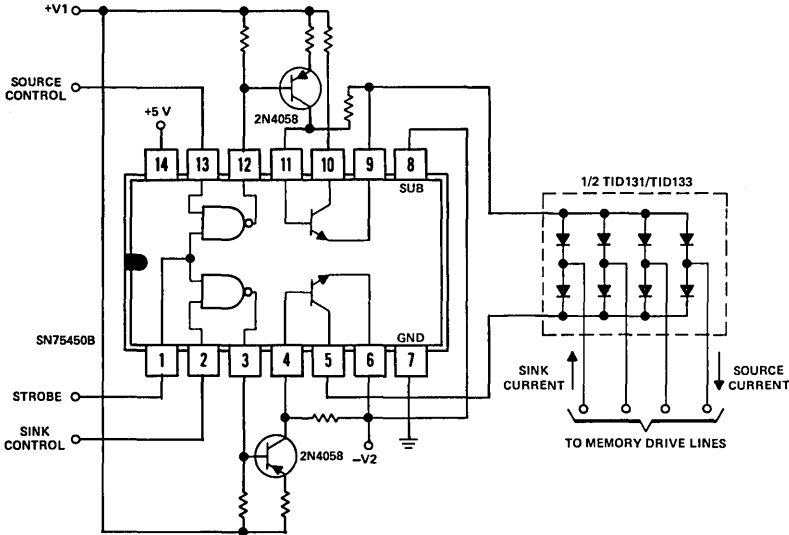

FIGURE 15 - DUAL HAMMER DRIVER

core memory driver and inhibit control



Source and sink controls are activated by high-level input voltages ( $V_{IH} \geq 2V$ )

FIGURE 16 - CORE MEMORY DRIVER

# TYPICAL APPLICATIONS

## core memory driver and inhibit control (continued)

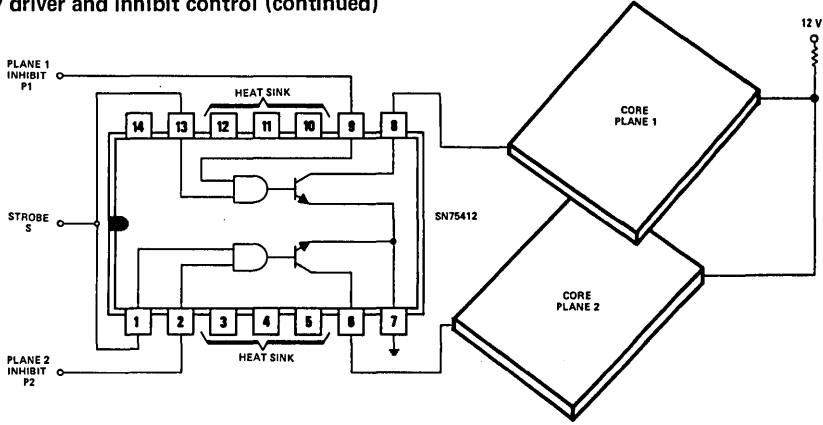

FUNCTION TABLE

INPUTS			OUTPUTS	
P1	P2	S	PLANE 1	PLANE 2
X	X	L	Enabled	Enabled
H	L	H	Inhibited	Enabled
L	H	H	Enabled	Inhibited
H	H	H	Inhibited	Inhibited
L	L	H	Enabled	Enabled

H = high level, L = low level, X = irrelevant

FIGURE 17—CORE MEMORY INHIBIT CONTROL

## digital comparators

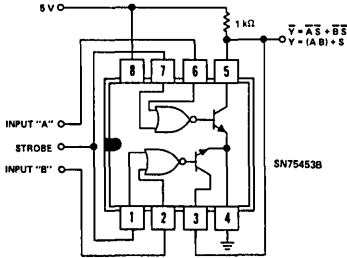

FIGURE 18—LOGIC SIGNAL COMPARATOR

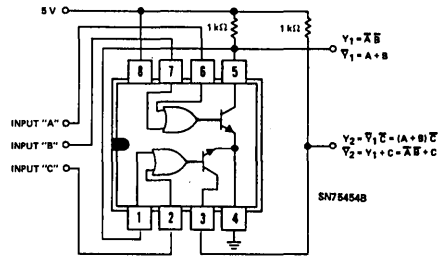

FIGURE 19—MULTIFUNCTION LOGIC-SIGNAL COMPARATOR

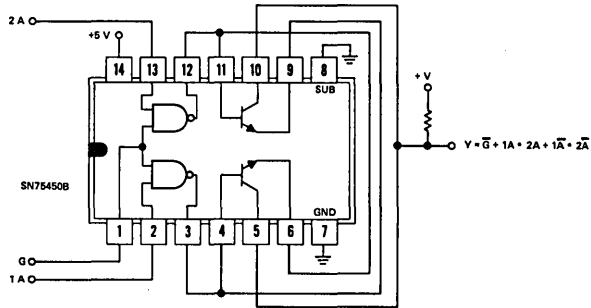
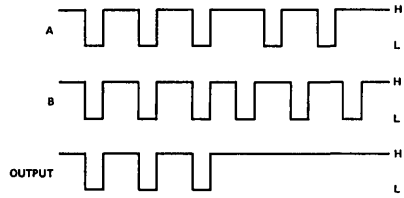
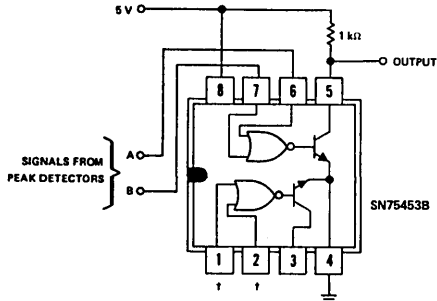

FIGURE 20—GATED COMPARATOR

# TYPICAL APPLICATIONS

## detectors



Low output occurs only when inputs are low simultaneously.

†If inputs are unused, they should be connected to +5 V through a 1 kΩ resistor.

FIGURE 21—IN-PHASE DETECTOR

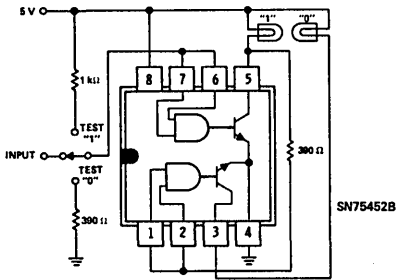
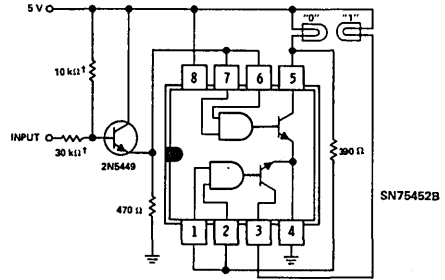

FIGURE 22—TTL OR DTL POSITIVE LOGIC-LEVEL DETECTOR



†The two input resistors must be adjusted for the level of MOS input.

FIGURE 23—MOS NEGATIVE-LOGIC-LEVEL DETECTOR

## TTL-to-MOS and MOS-to-TTL drivers

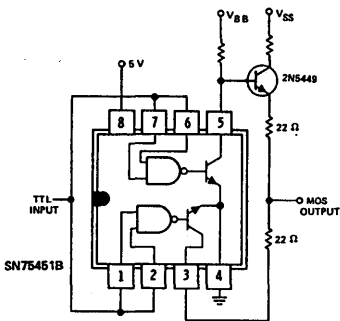
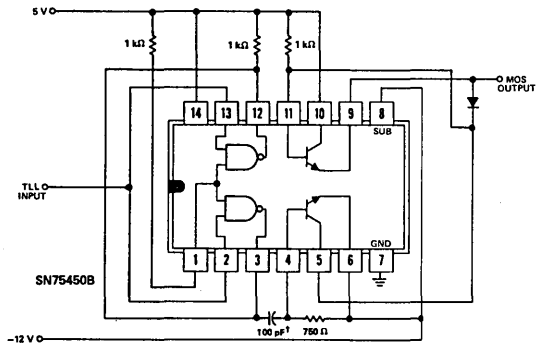

FIGURE 24—TTL-TO-MOS CLOCK DRIVER



†Value of coupling capacitor may need to be adjusted for frequency of operation.

FIGURE 25—TTL-TO-MOS CLOCK DRIVER

# TYPICAL APPLICATIONS

## TTL-to-MOS and MOS-to-TTL drivers (continued)

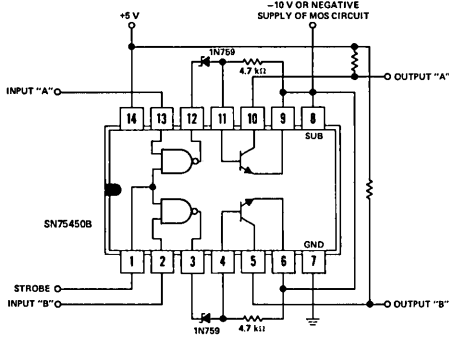

FIGURE 26—DUAL TTL-TO-MOS DRIVER

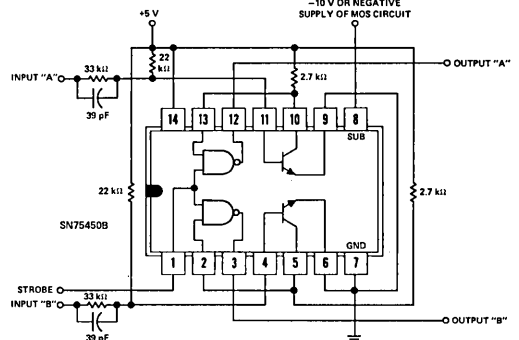

FIGURE 27—DUAL MOS-TO-TTL DRIVER

## inverting buffers for high-current loads

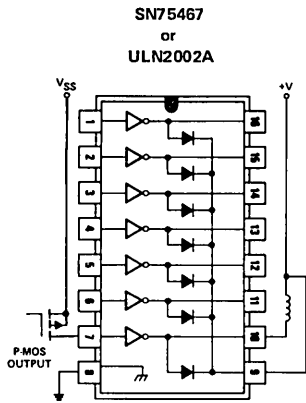

FIGURE 28—P-MOS TO LOAD

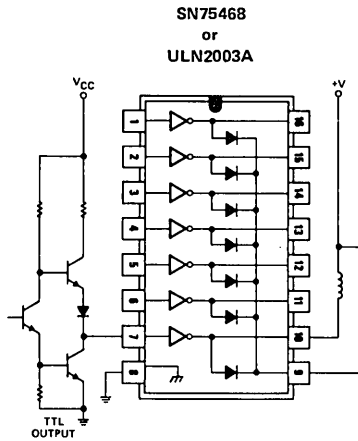

FIGURE 29—TTL TO LOAD

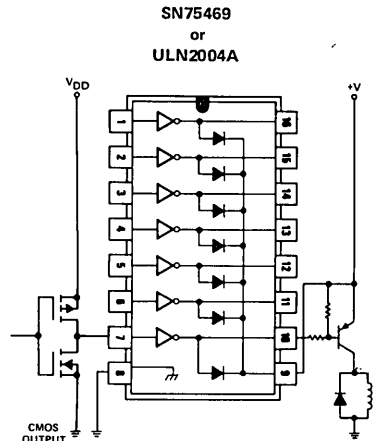

FIGURE 30—CMOS TO HIGHER CURRENT LOAD

miscellaneous applications

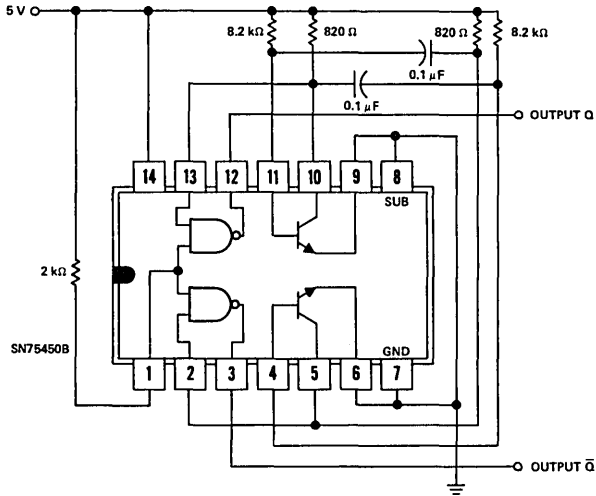

FIGURE 31—SQUARE-WAVE GENERATOR

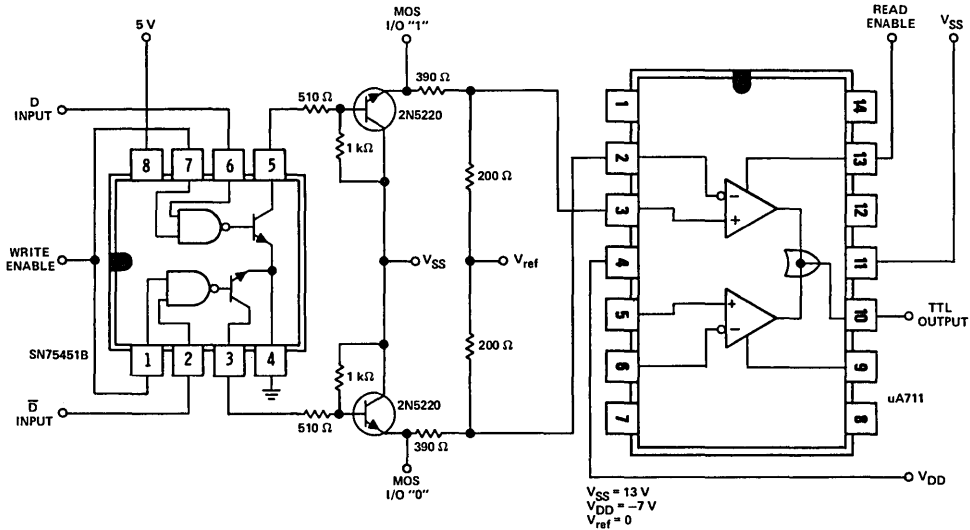

FIGURE 32—TTL COMPATIBLE DRIVER AND SENSE AMPLIFIER INTERFACE TO MOS MEMORY I/O LINES

# TYPICAL APPLICATIONS

## miscellaneous applications (continued)

4

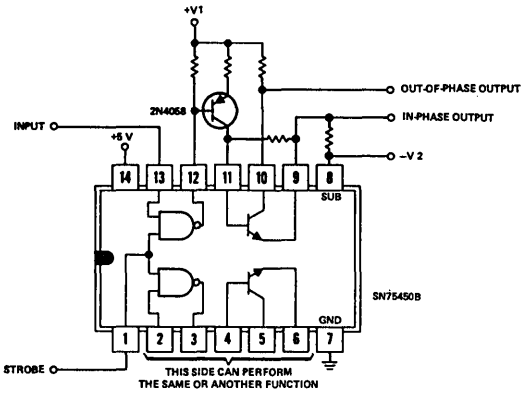

FIGURE 33—FLOATING SWITCH

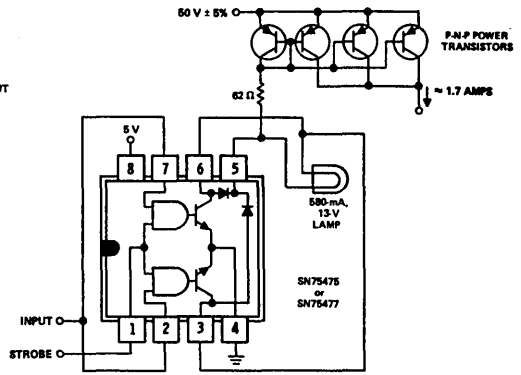

FIGURE 34—SWITCHABLE CURRENT SOURCE WITH INDICATOR LAMP

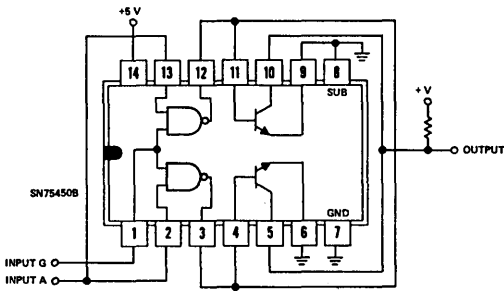

FIGURE 35—500-mA SINK

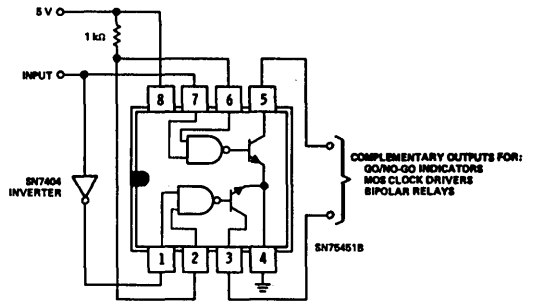
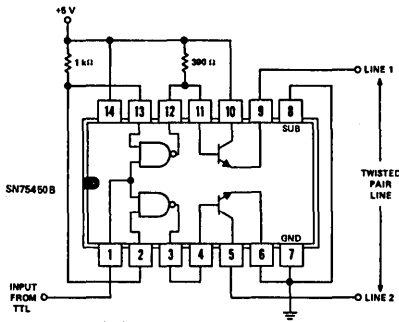

FIGURE 36—COMPLEMENTARY DRIVER



Termination is made at the receiving end as follows:  
 Line 1 is terminated to ground through  $Z_0/2$ ;  
 Line 2 is terminated to +5 volts through  $Z_0/2$ ;  
 where  $Z_0$  is the line impedance.

FIGURE 37—BALANCED LINE DRIVER

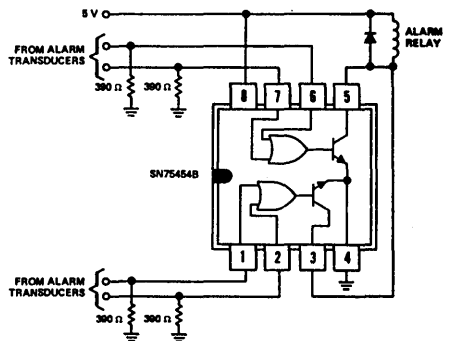

FIGURE 38—ALARM DETECTOR







## LINE DRIVER SELECTION GUIDE

APPLICATION	OUTPUT	DRIVERS PER PACKAGE	TYPE NUMBERS	PAGE NUMBER
EIA Standard RS-422A	Differential	2	SN55158, SN75158 SN75159 uA9638C	5-162 5-166 5-258
		4	AM26LS31C MC3487 SN55151, SN75151 SN55153, SN75153 SN75172 SN75174	5-11 5-39 5-139 5-139 5-187 5-197
EIA Committee TR30.1 Draft PN1360 (April 1980)	Differential	4	SN75172 SN75174	5-187 5-197
EIA Standard RS-423A	Single-Ended	2	SN75156† uA9636AC	5-158 5-251
		4	SN75186† SN75187†	5-234 5-235
EIA Standard RS-232C	Single-Ended	2	SN75150 SN75156† uA9636AC	5-135 5-158 5-251
		4	SN75186	5-234
IBM 360/370	Single-Ended	2	SN75123	5-101
			SN75126†	5-111
			SN75130†	5-116
General Purpose	Single-Ended	2	SN55121, SN75121 SN75361A SN55450B, SN75450B SN55451B, SN75451B	5-95 7-30 4-51 4-51
			4	DS7831, DS8831 DS7832, DS8832
	Differential	2		DS7831, DS8831 DS7832, DS8832 SN55109A, SN75109A SN55110A, SN75110A SN55113, SN75113 SN55114, SN75114 SN55183, SN75183 SN55450B, SN75450B SN75112

†Future Products.

**TEXAS INSTRUMENTS**  
INCORPORATED

POST OFFICE BOX 225012 • DALLAS, TEXAS 75265

# LINE RECEIVER SELECTION GUIDE

APPLICATION	INPUT	RECEIVERS PER PACKAGE	TYPE NUMBERS	PAGE NUMBER
EIA Standard RS-422A	Differential	2	SN75157 uA9637AC	5-159 5-255
		4	AM26LS32AC AM26LS33AC MC3486 SN75173 SN75175	5-15 5-15 5-35 5-192 5-202
EIA Committee TR30.1 Draft PN1360 (April 1980)	Differential	4	SN75173 SN75175	5-192 5-202
EIA Standard RS-423A	Single-Ended	2	SN75157 uA9637AC	5-159 5-255
		4	AM26LS32AC AM26LS33AC MC3486 SN75173 SN75175	5-15 5-15 5-35 5-192 5-202
EIA Standard RS-232C	Single-Ended	2	SN75152	5-146
		4	SN75154 SN75189 SN75189A	5-153 5-241 5-241
IBM 360/370	Single-Ended	3	SN75124	5-101
		7	SN75125 SN75127	5-107 5-107
		8	SN75128 SN75129	5-112 5-112
General Purpose	Single-Ended	2	SN55122, SN75122 SN55140, SN75140 SN55141, SN75141 SN55142A, SN75142A SN55143A, SN75143A	5-95 5-127 5-127 5-127 5-127
	Differential	2	SN55107A, SN75107A SN55107B, SN75107B SN55108A, SN75108A SN55108B, SN75108B SN55115, SN75115 SN55182, SN75182 SN75207 SN75207B SN75208 SN75208B	5-49 5-49 5-49 5-49 5-69 5-223 5-245 5-245 5-245 5-245

5

## LINE TRANSCEIVER SELECTION GUIDE

APPLICATION	BUS I/O	TRANSCEIVERS PER PACKAGE	TYPE NUMBERS	PAGE NUMBER
EIA Standard RS-422A	Differential	1	SN75176	5-207
			SN75177	5-215
			SN75178	5-215
EIA Committee TR30.1 Draft PN1360 (April 1980)	Differential	1	SN75176	5-207
			SN75177	5-215
			SN75178	5-215
IEEE Standard 488 GPIB	Single-Ended	4	MC3446	5-31
		8	SN75160A	5-171
			SN75161A SN75162A	5-177 5-177
General Purpose	Single-Ended	4	AM26S10M, AM26S10C	5-21
			AM26S11M, AM26S11C	5-21
			N8T26	5-43
	8	N8T26A	5-43	
		SN75136	5-117	
Differential	1	SN65138, SN75138	5-121	
		SN75163A	5-184	
		SN55116, SN75116	5-87	
			SN55117, SN75117	5-87
			SN55118, SN75118	5-87
			SN55119, SN75119	5-87

† Future products.

5

**TEXAS INSTRUMENTS**  
INCORPORATED

POST OFFICE BOX 225012 • DALLAS, TEXAS 75265

5-5

# INTERFACING TO IEEE STANDARD 488 GPIB

## Interfacing to IEEE Standard 488 GPIB

Because of the large number of manufacturers building programmable instruments that must be easily and economically interfaced, there is an overwhelming need for industry-wide standardization. For this reason the General-Purpose Interface Bus (GPIB) defined by IEEE Standard 488 has received wide acceptance in a short time with, at present, an estimated 500 commercially available instruments utilizing the GPIB. IEEE Std 488 has standardized the interface system used to interconnect programmable and non-programmable instruments, computers, and peripherals necessary to build an instrumentation system. This allows a user to purchase instruments from many different manufacturers and then connect them together using off-the-shelf cable. The GPIB uses a 16-line bidirectional bus that carries data at rates of up to 1 megabytes/second on eight lines, and hand-shaking and bus-management signals on the others. Up to 15 instruments can be tied together with a maximum line length of 20 meters. A typical interface arrangement is shown in Figure 1.

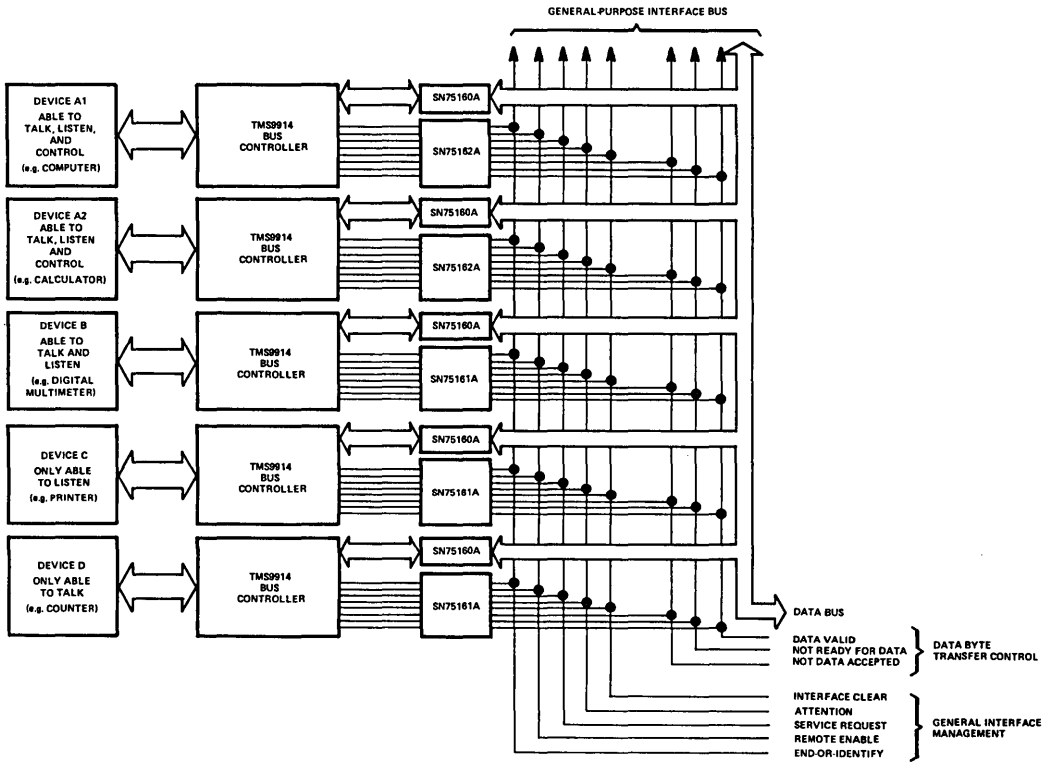

FIGURE 1—TYPICAL INTERFACE ARRANGEMENT

## INTERFACING TO IEEE STANDARD 488 GPIB

The TI SN75160 family of bus transceivers is designed to provide the interface between the GPIB (bus) and the bus controller. These transceivers may be used with the TMS 9914 bus controller or any of the other commercially available bus controllers. They provide the simplest method of interfacing because each part is tailored to either the 8-line data bus or the 8-line control bus and they require no extra logic or complicated board layout. All the transceivers in the SN75160 family have several features in common. Each driver output has a built-in termination network required by IEEE Std 488 designed so that, when power is removed from the transceiver, the output presents a high-impedance to the bus. Also, each receiver has a minimum of 400 millivolts hysteresis for additional noise margin. With the SN75160 family it takes only two 20-pin DIP packages to get on the GPIB.

The SN75160A is designed to implement the 8-line data bus and is pin-for-pin compatible with the original SN75160 series but with lower power and faster speeds as illustrated in Figure 2. The direction of data flow is controlled by the Talk Enable (TE) input. All eight channels are simultaneously in the receive mode when TE is low, and data is received from the bus and transferred to the bus controller. When TE is in the high state, all eight channels go to the transmit mode, and data will be transmitted onto the bus. Each driver features a totem-pole output which can actively drive the bus high or low to give the fastest data rates possible. The SN75160A has a Pull-up Enable (PE) input which, when taken low, disables the upper stage of all eight driver outputs to turn them into open-collector-type outputs. The open-collector-output mode does not allow data rates as fast as is possible with the totem-pole, but it does allow more than one instrument to be transmitting on the bus at the same time. This feature is used in parallel polling where up to eight instruments may be polled simultaneously, each responding on a single line of the eight-line data bus, thus greatly speeding up the polling process. They may then be switched back to the totem-pole mode for regular data transmission.

The SN75161A is used to implement the eight-line control bus. It includes with the Talk-Enable (TE) and Direction-Control (DC) inputs the necessary logic to enable each channel in the correct direction for the exchange of bus-management and hand-shaking signals. Three of the channels, (NDAC, NRFD, and SRQ) have open-collector driver outputs as required by the IEEE Std 488. These lines are always used in a Wired-OR configuration. The other five channels have totem-pole outputs.

The SN75162A offers an alternate method of implementing the eight-line control bus. It is identical to the SN75161A except that the direction of the REN and IFC channels is controlled by a separate input called the System Controller (SC). With this additional flexibility, control of the entire bus system may be transferred from one instrument to another in multiple-controller systems. Because of this extra input the SN75162A is packaged in a 22-pin DIP.

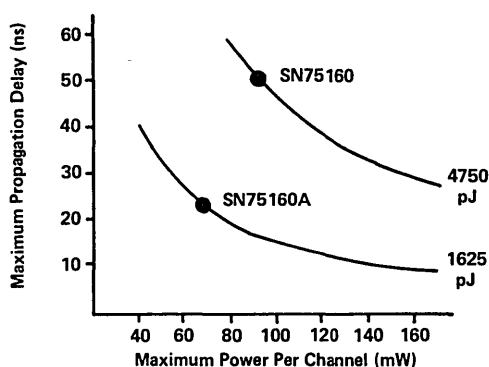

FIGURE 2

# EIA STANDARDS

## EIA Standards

There are two basic methods for electronic communication between components of a data processing system: single-ended transmission, which uses only one signal line, and differential transmission, which uses two signal lines. Single-ended transmission is used only for short distances and slower data rates since, as line length increases, it is difficult to distinguish between a valid data signal and invalid signals, such as ground shifts and noise, introduced by the environment. Differential data transmission overcomes these problems. Unwanted signals appear as common-mode levels and are rejected by the differential line receiver.

The Electronic Industries Association (EIA) has developed several specifications to standardize the interface system in data communications. Table 1 shows the key aspects of each of these specifications.

RS-232 was introduced in 1962 and has been widely used throughout the industry. It was developed for single-ended transmission over short distances at slow data rates. Today's higher-performance systems, demanding data transmission at faster rates over longer distances, are rapidly making RS-232 inadequate. The newer standard for single-ended

systems, RS-423, extends the maximum data rate to 100 kilobits per second (up to 300 feet) and the maximum distance to 4000 feet (up to 1 kb/s). It also provides wave shaping dependent on data rate and wire length to control reflections and radiated emission or cross-talk. Another improvement of RS-423 is the requirement for high-impedance outputs when component power is off to avoid loading the transmission line.

For data rates over 100 kb/s and for long distances, differential transmission should be used to nullify effects of ground shifts and noise signals, which appear as common-mode voltages on the bus. EIA Standard RS-422 defines a differential interface that allows data rates up to 10 Mb/s (up to 40 feet) and line lengths up to 4000 feet (up to 100 kb/s). Line drivers designed to meet this standard are capable of transmitting a 2-V-minimum differential signal on a twisted-pair line terminated in 100  $\Omega$ . The receivers are capable of detecting  $\pm 200$ -mV differential signals in the presence of common-mode levels from  $-7$  V to 7 V.

5

TABLE 1

SPECIFICATION		RS-232C	RS-423A	RS-422A	EIA Committee TR30.1 Draft Standard PN1360
Mode of operation		Single-ended	Single-ended	Differential	Differential
Number of drivers and receivers allowed on one line		1 Driver, 1 Receiver	1 Driver, 10 Receivers	1 Driver, 10 Receivers	32 Drivers, 32 Receivers
Maximum cable length		50 feet	4000 feet	4000 feet	4000 feet
Maximum data rate		20 kb/s	100 kb/s	10 Mb/s	10 mb/s
Maximum voltage applied to driver output		$\pm 25$ V	$\pm 6$ V	$-0.25$ V to 6 V	$-7$ V to 12 V
Driver output signal	Loaded	$\pm 5$ V	$\pm 3.6$ V	$\pm 2$ V	$\pm 1.5$ V
	Unloaded	$\pm 15$ V	$\pm 6$ V	$\pm 5$ V	$\pm 5$ V
Driver load		3 k $\Omega$ to 7 k $\Omega$	450 $\Omega$ min	100 $\Omega$	54 $\Omega$
Maximum driver output current (High-impedance state)	Power on	---	---	---	$\pm 100$ $\mu$ A
	Power off	$V_{max}/300$ $\Omega$	$\pm 100$ $\mu$ A	$\pm 100$ $\mu$ A	$\pm 100$ $\mu$ A
Output slew rate		30 V/ $\mu$ s max	Controls provided	---	---
Receiver input voltage range		$\pm 15$ V	$\pm 12$ V	$-7$ V to 7 V	$-7$ V to 12 V
Receiver input sensitivity		$\pm 3$ V	$\pm 200$ mV	$\pm 200$ mV	$\pm 200$ mV
Receiver input resistance		3 k $\Omega$ to 7 k $\Omega$	4 k $\Omega$ min	4 k $\Omega$ min	12 k $\Omega$ min



The main limitations of RS-422 occur in systems where output drivers of several components or subassemblies are connected to the same bus line. Ideally, only one driver on a line should be active (high or low) at a time, and all the others should be in a high-impedance state that prevents loading the line even when subassembly power is off. RS-422 does not require that drivers be in a high-impedance state except when the power supply is off, and then only for common-mode bus voltages from  $-0.25$  volts to 6 volts. In systems where large positive and negative common-mode signals can appear on the bus, it is necessary that driver outputs maintain a high impedance over a wide range of common-mode voltage when disabled with power on or when power is off.

Another limitation of RS-422 occurs when more than one driver is enabled. The outputs may be in contention (trying

to drive the bus to opposite logic states) or there may be a large difference in common-mode voltages. In either case, relatively large currents can cause excessive power dissipation and possible damage.

EIA Committee TR30.1 is, at the time of this publication, drafting a new standard (Project Number 1360) patterned after RS-422 (See Figure 1) but specified for multipoint interface. It is intended to allow for as many as 32 driver-receiver pairs on a data bus otherwise very similar to that of RS-422. Key features of the new standard are:

- Up to 32 Components Interfaced to One Bus
- Extended Common-Mode Voltage Range with Power On or Off
- Contention Protection for Drivers
- Receiver Sensitivity of  $\pm 200$  millivolts
- Receiver Input Impedance Increased to  $12\text{ k}\Omega$  Min

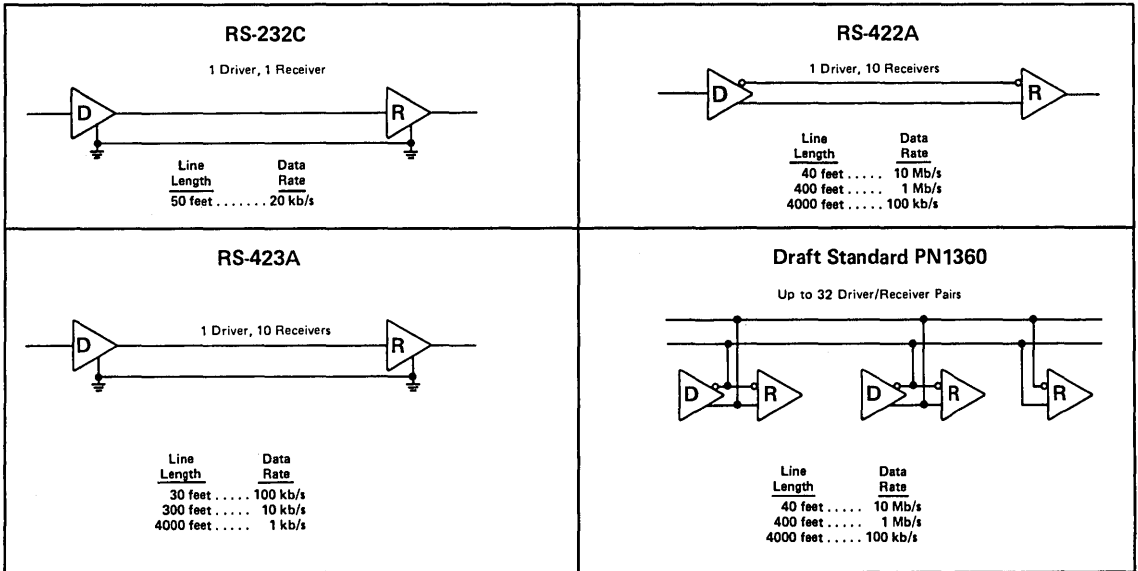

FIGURE 1

## EIA STANDARDS

5

The new SN75172 and SN75174 drivers, and SN75173 and SN75175 receivers are available now for systems designed around either RS-422 or present PN1360 requirements. The drivers operate from a single 5-V supply and maintain high output impedance with power on or off. This improved design was achieved without appreciable sacrifice in speed, since they have maximum delay times of 50 ns and rise and fall times of 80 ns, and the data rate can be as high as 4 Mb/s. Also featured is the low maximum power requirement of 79 mW per enabled channel and 53 mW per disabled channel. These drivers provide contention protection through positive- and negative-current limiting and thermal shutdown. Each output is limited to  $-250$  mA sink current and to 500 mA source current over the maximum output voltage range of  $-7$  V to 12 V, and a thermal sensing circuit will cause these devices to go into a disabled state whenever the internal temperature exceeds approximately  $150^{\circ}\text{C}$ .

The SN75173 and SN75175 quadruple receivers are similar to existing RS-422 receivers but have higher input impedance and extended common-mode range without any sacrifice in sensitivity or speed. They feature  $\pm 200$  mV sensitivity over a common-mode input range of  $\pm 12$  V,  $12$  k $\Omega$  input impedance, and 35 ns propagation delay. Each receiver has 50 mV input hysteresis for increased noise margin.

Other new devices include the SN75176 transceiver, the equivalent of one SN75172 driver and one SN75173 receiver interconnected (see Figure 2) in a single 8-pin package. The SN75177 and SN75178 transceivers are designed for use as repeaters to extend the maximum cable distance. The enable controls on all these devices are complementary to allow bidirectional data communication.

Figure 1 illustrates how several of these new devices might be combined in a typical bus system. The SN75177 and SN75178 are connected to form a bidirectional repeater to extend the cable length. Other devices interface with terminals or MODEMs and drive peripherals. The twisted-pair line should normally be terminated at each end of the main wire lengths in  $120\text{-}\Omega$  resistors.

Texas Instruments manufactures a wide variety of integrated circuits designed to meet the requirements of EIA Standards RS-232C, RS-422A, RS-423A, and draft standard PN1360. This variety offers flexibility, choice, and compatibility that will provide cost-effective solutions to many interfacing problems.

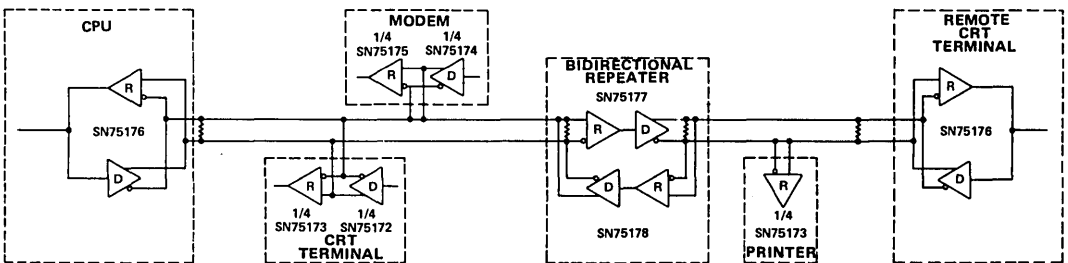

FIGURE 2

# INTERFACE CIRCUITS

# TYPES AM26LS31M, AM26LS31C QUADRUPLE DIFFERENTIAL LINE DRIVERS

BULLETIN NO. DL-S 12671, JANUARY 1979 — REVISED SEPTEMBER 1980

- Meets EIA Standard RS-422A
- Operates from a Single 5-V Supply
- TTL-, DTL-Compatible
- Complementary Outputs
- High Output Impedance in Power-Off Conditions
- Complementary Output Enable Inputs

## description

The AM26LS31M and AM26LS31C are quadruple complementary-output line drivers designed to meet the requirements of EIA Standard RS-422 and Federal Standard 1020. The three-state outputs have high-current capability for driving balanced lines such as twisted-pair or parallel-wire transmission lines, and they provide a high-impedance state in the power-off condition. The enable function is common to all four drivers and offers a choice of active-high or active-low inputs. Low-power Schottky circuitry reduces power consumption without sacrificing speed.

The AM26LS31M is characterized for operation over the full military temperature range of  $-55^{\circ}\text{C}$  to  $125^{\circ}\text{C}$ , the AM26LS31C is characterized for operation from  $0^{\circ}\text{C}$  to  $70^{\circ}\text{C}$ .

AM26LS31M . . . J  
AM26LS31C . . . J OR N  
DUAL-IN-LINE PACKAGE (TOP VIEW)

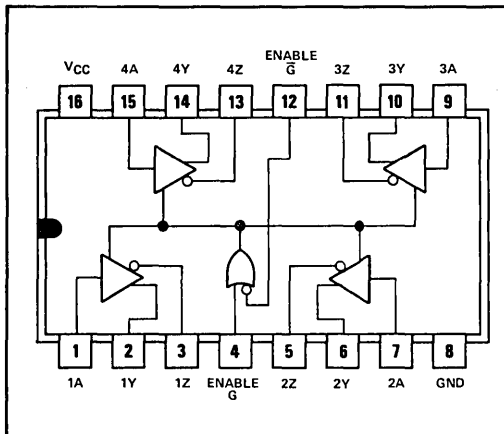

FUNCTION TABLE (EACH DRIVER)

INPUT A	ENABLES		OUTPUTS	
	G	$\bar{G}$	Y	Z
H	H	X	H	L
L	H	X	L	H
H	X	L	H	L
L	X	L	L	H
X	L	H	Z	Z

H = high level  
L = low level  
X = irrelevant  
Z = high impedance (off)

## schematic (each driver)

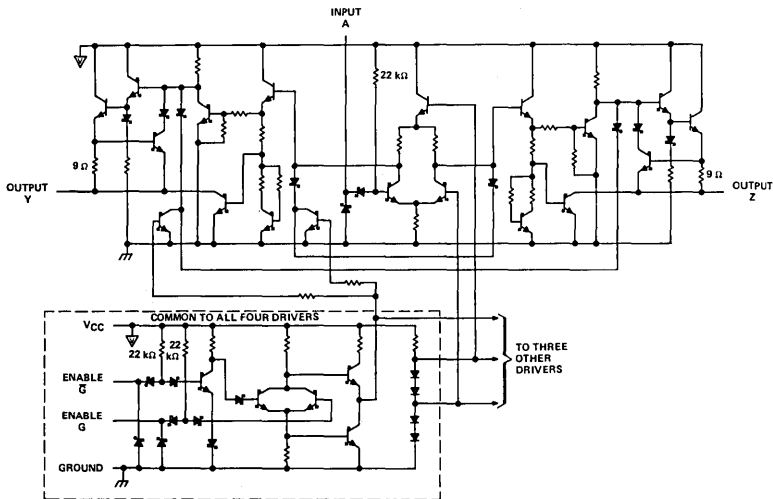

Copyright © 1979 by Texas Instruments Incorporated

TEXAS INSTRUMENTS  
INCORPORATED

POST OFFICE BOX 225012 • DALLAS, TEXAS 75265

# TYPES AM26LS31M, AM26LS31C

## QUADRUPLE DIFFERENTIAL LINE DRIVERS

absolute maximum ratings over operating free-air temperature range (unless otherwise noted)

Supply voltage, $V_{CC}$ (see Note 1)	7 V
Input voltage	7 V
Output off-state voltage	5.5 V
Continuous total dissipation at (or below) 25°C free-air temperature (see Note 2)	1 W
Operating free-air temperature range: AM26LS31M	-55°C to 125°C
AM26LS31C	0°C to 70°C
Storage temperature range	-65°C to 150°C
Lead temperature 1/16 inch (1,6 mm) from case for 60 seconds: J package	300°C
Lead temperature 1/16 inch (1,6 mm) from case for 10 seconds: N package	260°C

- NOTES: 1. All voltage values, except differential output voltage  $V_{OD}$ , are with respect to network ground terminal.  
 2. For operation above 25°C free-air temperature, refer to the Dissipation Derating Table. In the J package, AM26LS31M chips are alloy-mounted; AM26LS31C chips are glass-mounted.

DISSIPATION DERATING TABLE

PACKAGE	POWER RATING	DERATING FACTOR	ABOVE $T_A$
J (Alloy-Mounted Chip)	1000 mW	11.0 mW/°C	59°C
J (Glass-Mounted Chip)	1000 mW	8.2 mW/°C	28°C
N	1000 mW	9.2 mW/°C	41°C

5

recommended operating conditions

	AM26LS31M			AM26LS31C			UNIT
	MIN	NOM	MAX	MIN	NOM	MAX	
Supply voltage, $V_{CC}$	4.5	5	5.5	4.75	5	5.25	V
High-level output current, $I_{OH}$			-20			-20	mA
Low-level output current, $I_{OL}$			20			20	mA
Operating free-air temperature, $T_A$	-55		125	0		70	°C

electrical characteristics over operating free-air temperature range (unless otherwise noted)

PARAMETER	TEST CONDITIONS†	MIN	TYP‡	MAX	UNIT
$V_{IH}$ High-level input voltage		2			V
$V_{IL}$ Low-level input voltage				0.8	V
$V_{IK}$ Input clamp voltage	$V_{CC} = \text{MIN}, I_I = -18 \text{ mA}$			-1.5	V
$V_{OH}$ High-level output voltage	$V_{CC} = \text{MIN}, I_{OH} = -20 \text{ mA}$	2.5			V
$V_{OL}$ Low-level output voltage	$V_{CC} = \text{MIN}, I_{OL} = 20 \text{ mA}$			0.5	V
$I_{OZ}$ Off-state (high-impedance-state) output current	$V_{CC} = \text{MAX}$			$V_O = 0.5 \text{ V}$	-20
				$V_O = 2.5 \text{ V}$	20
$I_I$ Input current at maximum input voltage	$V_{CC} = \text{MAX}, V_I = 7 \text{ V}$			0.1	mA
$I_{IH}$ High-level input current	$V_{CC} = \text{MAX}, V_I = 2.7 \text{ V}$			20	µA
$I_{IL}$ Low-level input current	$V_{CC} = \text{MAX}, V_I = 0.4 \text{ V}$			-0.36	mA
$I_{OS}$ Short-circuit output current§	$V_{CC} = \text{MAX}$	-30		-150	mA
$I_{CC}$ Supply current (both drivers)	$V_{CC} = \text{MAX},$ All outputs disabled		32	80	mA

† For conditions shown as MIN or MAX, use the appropriate value specified under recommended operating conditions.

‡ All typical values are at  $V_{CC} = 5 \text{ V}$  and  $T_A = 25^\circ\text{C}$ .

§ Not more than one output should be shorted at a time, and duration of the short-circuit should not exceed one second.

# TYPES AM26LS31M, AM26LS31C QUADRUPLE DIFFERENTIAL LINE DRIVERS

switching characteristics,  $V_{CC} = 5\text{ V}$ ,  $T_A = 25^\circ\text{C}$

PARAMETER	TEST CONDITIONS	MIN	TYP	MAX	UNIT
$t_{PLH}$ Propagation delay time, low-to-high-level output	$C_L = 30\text{ pF}$ , See Figure 1, S1 and S2 open	14	20		ns
$t_{PHL}$ Propagation delay time, high-to-low-level output		14	20		ns
Output-to-output skew		1	6		ns
$t_{PZH}$ Output enable time to high level	$C_L = 30\text{ pF}$ , $R_L = 75\ \Omega$ , See Figure 1	25	40		ns
$t_{PZL}$ Output enable time to low level	$C_L = 30\text{ pF}$ , $R_L = 180\ \Omega$ , See Figure 1	37	45		ns
$t_{PHZ}$ Output disable time from high level	$C_L = 10\text{ pF}$ , See Figure 1, S1 and S2 closed	21	30		ns
$t_{PLZ}$ Output disable time from low level		23	35		ns

## PARAMETER MEASUREMENT INFORMATION

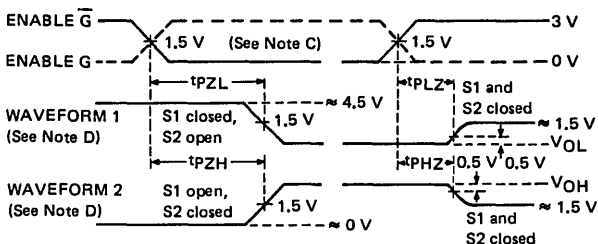
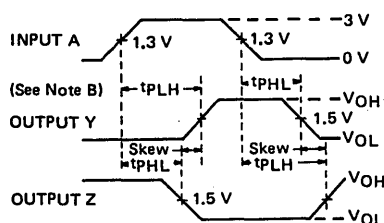

### PROPAGATION DELAY TIMES AND SKEW

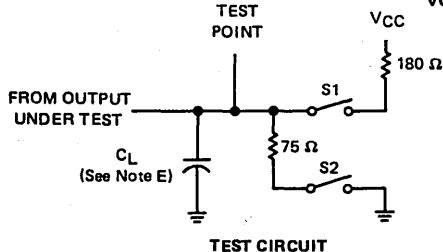

TEST CIRCUIT

### ENABLE AND DISABLE TIMES

#### VOLTAGE WAVEFORMS

- NOTES: A. All input pulses are supplied by generators having the following characteristics:  $PRR < 1\text{ MHz}$ ,  $Z_{out} \approx 50\ \Omega$ ,  $t_r < 15\text{ ns}$ , and  $t_f < 6\text{ ns}$ .
- B. When measuring propagation delay times and skew, switches S1 and S2 are open.
- C. Each enable is tested separately.
- D. Waveform 1 is for an output with internal conditions such that the output is low except when disabled by the output control. Waveform 2 is for an output with internal conditions such that the output is high except when disabled by the output control.
- E.  $C_L$  includes probe and jig capacitance.

FIGURE 1—SWITCHING TIMES

## TYPICAL CHARACTERISTICS†

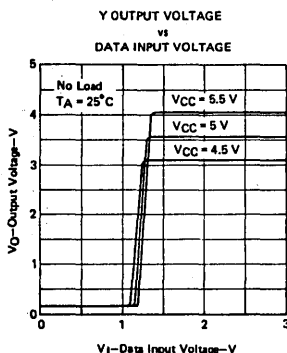

FIGURE 2

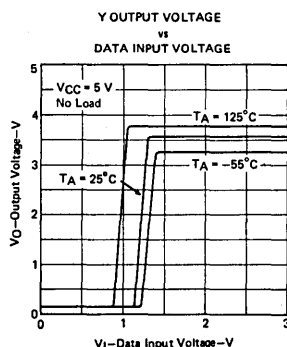

FIGURE 3

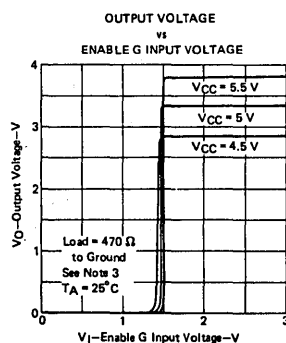

FIGURE 4

NOTE 3: The A input is connected to  $V_{CC}$  during the testing of the Y outputs and to ground during testing of the Z outputs.

†Data for temperatures below  $0^\circ\text{C}$  and above  $70^\circ\text{C}$  are applicable to AM26LS31M circuits only.

# TYPES AM26LS31M, AM26LS31C

## QUADRUPLE DIFFERENTIAL LINE DRIVERS

### TYPICAL CHARACTERISTICS†

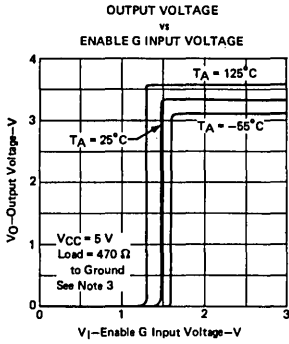

FIGURE 5

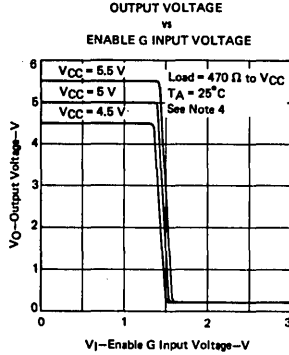

FIGURE 6

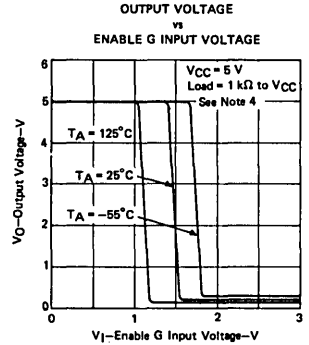

FIGURE 7

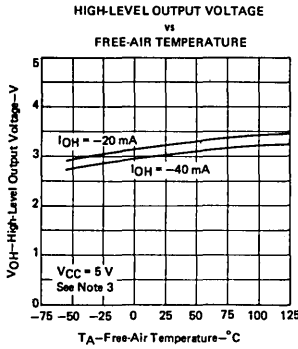

FIGURE 8

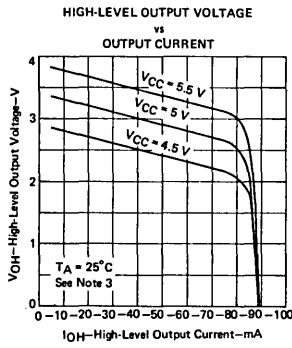

FIGURE 9

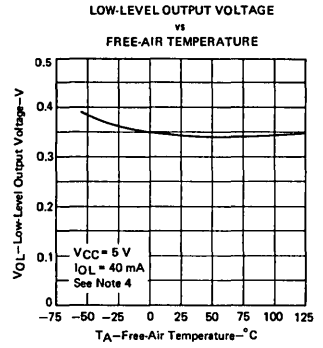

FIGURE 10

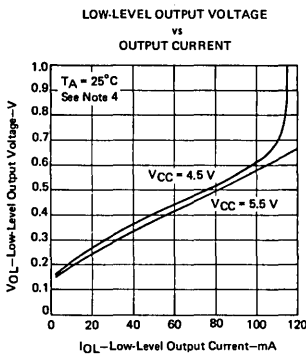

FIGURE 11

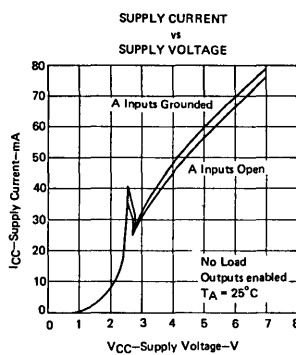

FIGURE 12

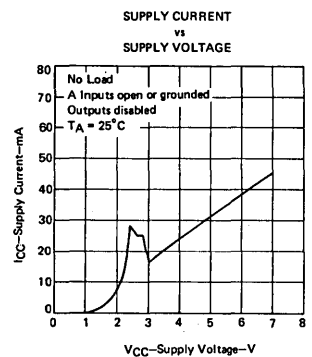

FIGURE 13

NOTES: 3. The A Input is connected to  $V_{CC}$  during the testing of the Y outputs and to ground during testing of the Z outputs.

4. The A input is connected to ground during the testing of the Y outputs and to  $V_{CC}$  during the testing of the Z outputs.

†Data for temperature below  $0^{\circ}\text{C}$  and above  $70^{\circ}\text{C}$  are applicable to AM26LS31M circuits only.

# INTERFACE CIRCUITS

# TYPES AM26LS32AC, AM26LS33AC QUADRUPLE DIFFERENTIAL LINE RECEIVERS

BULLETIN NO. DL-S 12655, OCTOBER 1980

- AM26LS32AC Meets EIA Standards RS-422A and RS-423A
- AM26LS32AC has  $\pm 7$ -V Common-Mode Range with  $\pm 200$ -mV Sensitivity
- AM26LS33AC has  $\pm 15$ -V Common-Mode Range with  $\pm 500$  mV Sensitivity
- Input Hysteresis . . . 50 mV Typical
- Operates From a Single 5-V Supply
- Low-Power Schottky Circuitry
- 3-State Outputs
- Complementary Output Enable Inputs
- Input Impedance . . . 12 k $\Omega$  Min
- Designed to be Interchangeable with Advanced Micro Devices AM26LS32C and AM26LS33C

### description

The AM26LS32AC and AM26LS33AC are quadruple line receivers for balanced and unbalanced digital data transmission. The enable function is common to all four receivers and offers a choice of active-high or active-low input. Three-state outputs permit connection directly to a bus-organized system. Fail-safe design ensures that if the inputs are open, the outputs will always be high.

Compared to the AM26LS32C and the AM26LS33C, the AM26LS32AC and AM26LS33AC incorporate an additional stage of amplification to improve sensitivity. The input impedance has been increased resulting in less loading of the bus line. The additional stage has increased propagation delay; however, this will not affect interchangeability in most applications.

The AM26LS32AC and the AM26LS33AC are characterized for operation from 0°C to 70°C.

### schematics of inputs and outputs

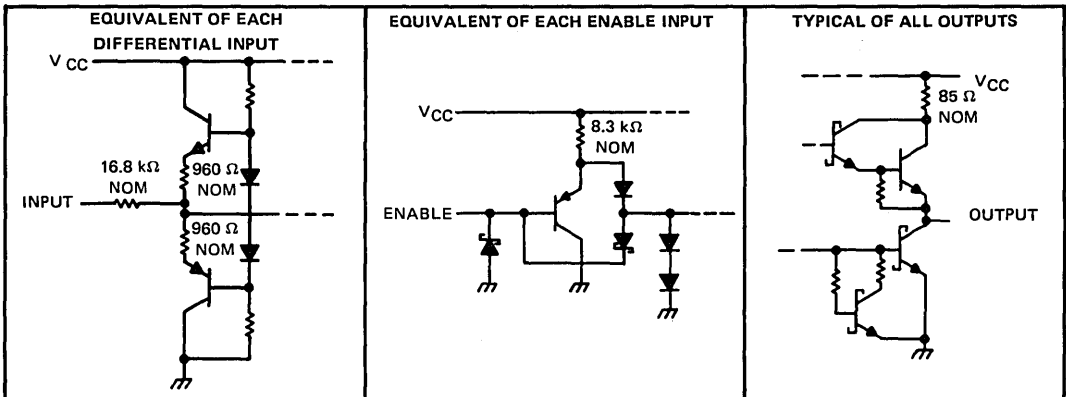

JORN DUAL-IN-LINE PACKAGE  
(TOP VIEW)

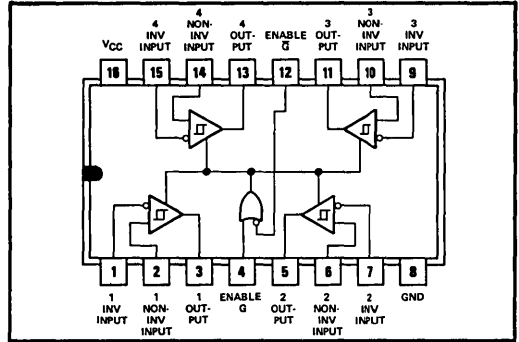

FUNCTION TABLE (EACH RECEIVER)

DIFFERENTIAL INPUT	ENABLES		OUTPUT
	G	$\bar{G}$	
$V_{ID} > V_{TH}$	H	X	H
$V_{TL} < V_{ID} < V_{TH}$	X	L	H
$V_{ID} < V_{TL}$	H	X	L
$V_{ID} < V_{TL}$	X	L	L
X	L	H	Z

H = high level, L = low level, X = irrelevant  
Z = high impedance (off), ? = indeterminate

# TYPES AM26LS32AC, AM26LS33AC

## QUADRUPLE DIFFERENTIAL LINE RECEIVERS

### absolute maximum ratings over operating free-air temperature range (unless otherwise noted)

Supply voltage, $V_{CC}$ (see Note 1)	7 V
Input voltage, any differential input	$\pm 25$ V
Differential input voltage (see Note 2)	$\pm 25$ V
Enable input voltage	7 V
Low-level output current	50 mA
Continuous total dissipation at (or below) 25°C free-air temperature (see Note 3)	1 W
Operating free-air temperature range	0°C to 70°C
Storage temperature range	-65°C to 150°C
Lead temperature 1/16 inch (1,6 mm) from case for 60 seconds: J package	300°C
Lead temperature 1/16 inch (1,6 mm) from case for 10 seconds: N package	260°C

- NOTES: 1. All voltage values, except differential voltages, are with respect to the network ground terminal.  
 2. Differential voltage values are at the noninverting terminal with respect to the inverting terminal.  
 3. For operation above 25°C free-air temperature, refer to Dissipation Derating Table. In the J package the chips are glass-mounted.

DISSIPATION DERATING TABLE

PACKAGE	POWER RATING	DERATING FACTOR	ABOVE $T_A$
J (Glass-Mounted Chip)	1000 mW	8.2 mW/°C	28°C
N	1000 mW	9.2 mW/°C	41°C

### recommended operating conditions

	AM26LS32AC			AM26LS33AC			UNIT
	MIN	NOM	MAX	MIN	NOM	MAX	
Supply voltage, $V_{CC}$	4.75	5	5.25	4.75	5	5.25	V
Common-mode input voltage, $V_{IC}$	$\pm 7$			$\pm 15$			V
High-level output current, $I_{OH}$	-440			-440			$\mu$ A
Low-level output current, $I_{OL}$	8			8			mA
Operating free-air temperature, $T_A$	0	70		0	70		°C



# TYPES AM26LS32AC, AM26LS33AC QUADRUPLE DIFFERENTIAL LINE RECEIVERS

electrical characteristics over recommended ranges of  $V_{CC}$ ,  $V_{IC}$ , and operating free-air temperature (unless otherwise noted)

PARAMETER	TEST CONDITIONS		MIN	TYP†	MAX	UNIT
$V_{TH}$ Differential input high-threshold voltage	$V_{OH} = 2.7\text{ V}$ ,	$I_{OH} = -440\ \mu\text{A}$			0.2 0.5	V
$V_{TL}$ Differential input low-threshold voltage	$V_{OL} = 0.45\text{ V}$ ,	$I_{OL} = 8\text{ mA}$			-0.2‡ -0.5‡	V
$V_{T+} - V_{T-}$ Hysteresis§				50		mV
$V_{IH}$ High-level enable input voltage				2		V
$V_{IL}$ Low-level enable input voltage					0.8	V
$V_{IK}$ Enable input clamp voltage	$V_{CC} = 4.75\text{ V}$ ,	$I_I = -18\text{ mA}$			-1.5	V
$V_{OH}$ High-level output voltage	$V_{CC} = 4.75\text{ V}$ , $V_{I(\overline{G})} = 0.8\text{ V}$ ,	$V_{ID} = 1\text{ V}$ , $I_{OH} = -440\ \mu\text{A}$	2.7	3.5		V
$V_{OL}$ Low-level output voltage	$V_{CC} = 4.75\text{ V}$ , $V_{I(\overline{G})} = 0.8\text{ V}$	$V_{ID} = -1\text{ V}$ , $I_{OL} = 4\text{ mA}$ $I_{OL} = 8\text{ mA}$			0.4 0.45	V
$I_{OZ}$ Off-state (high-impedance-state) output current	$V_{CC} = 5.25\text{ V}$ ,	$V_O = 2.4\text{ V}$ $V_O = 0.4\text{ V}$			20 -20	$\mu\text{A}$
$I_I$ Line input current	$V_I = 15\text{ V}$ , $V_I = -15\text{ V}$ ,	Other input at $-10\text{ V}$ to $15\text{ V}$ Other input at $-15\text{ V}$ to $10\text{ V}$			1.2 -1.7	mA
$I_{I(EN)}$ Enable input current	$V_I = 5.5\text{ V}$				100	$\mu\text{A}$
$I_{IH}$ High-level enable current	$V_I = 2.7\text{ V}$				20	$\mu\text{A}$
$I_{IL}$ Low-level enable current	$V_I = 0.4\text{ V}$				-0.36	mA
$r_i$ Input resistance	$V_{IC} = -15\text{ V}$ to $15\text{ V}$ ,	One input to AC ground	12	15		k $\Omega$
$I_{OS}$ Short-circuit output current¶	$V_{CC} = 5.25\text{ V}$ ,		-15		-85	mA
$I_{CC}$ Supply current	$V_{CC} = 5.25\text{ V}$ , All outputs disabled	Data inputs at $0\text{ V}$ ,		52	70	mA

† All typical values are at  $V_{CC} = 5\text{ V}$ ,  $T_A = 25^\circ\text{C}$ , and  $V_{IC} = 0$ .

‡ The algebraic convention, where the less-positive (more-negative) limit is designated as minimum, is used in this data sheet for threshold levels only.

§ Hysteresis is the difference between the positive-going input threshold voltage,  $V_{T+}$ , and the negative-going input threshold voltage,  $V_{T-}$ . See Figures 10 and 11.

¶ Not more than one output should be shorted at a time.

switching characteristics,  $V_{CC} = 5\text{ V}$ ,  $T_A = 25^\circ\text{C}$

PARAMETER	TEST CONDITIONS		MIN	TYP	MAX	UNIT
$t_{PLH}$ Propagation delay time, low-to-high-level output	$C_L = 15\text{ pF}$ ,	See Figure 1		20	35	ns
$t_{PHL}$ Propagation delay time, high-to-low-level output				22	35	ns
$t_{PZH}$ Output enable time to high level	$C_L = 15\text{ pF}$ ,	See Figure 1		17	22	ns
$t_{PZL}$ Output enable time to low level				20	25	ns
$t_{PHZ}$ Output disable time from high level	$C_L = 5\text{ pF}$ ,	See Figure 1		21	30	ns
$t_{PLZ}$ Output disable time from low level				30	40	ns

# TYPES AM26LS32AC, AM26LS33AC QUADRUPLE DIFFERENTIAL LINE RECEIVERS

## PARAMETER MEASUREMENT INFORMATION

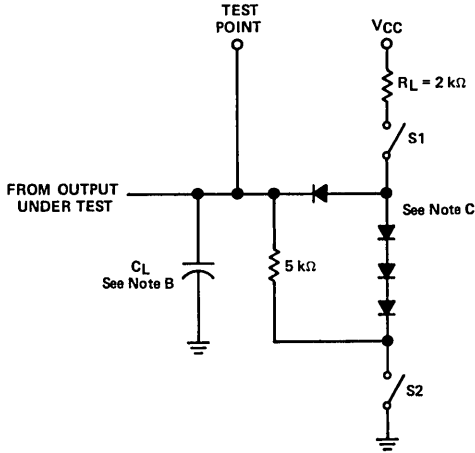

TEST CIRCUIT

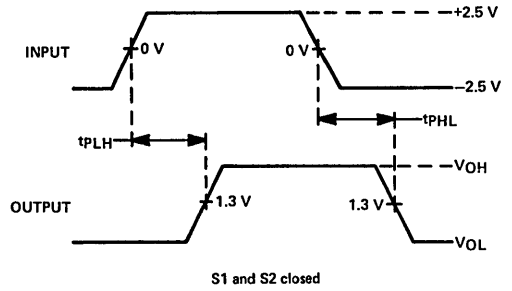

VOLTAGE WAVEFORMS FOR  $t_{pLH}$ ,  $t_{pHL}$

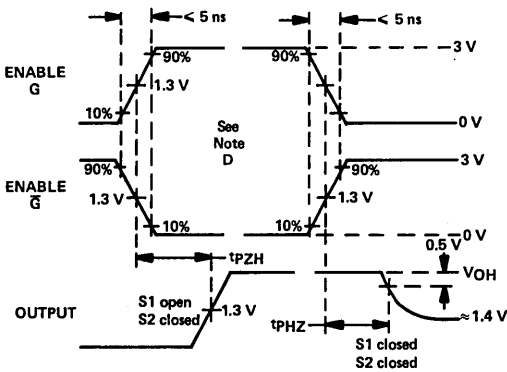

VOLTAGE WAVEFORMS FOR  $t_{pZH}$ ,  $t_{pZH}$

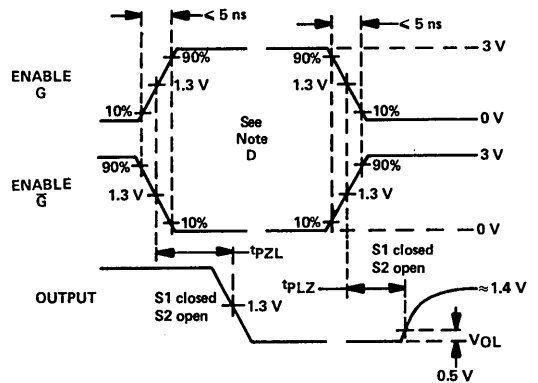

VOLTAGE WAVEFORMS FOR  $t_{pLZ}$ ,  $t_{pZL}$

- NOTES: A. The pulse generator has the following characteristics:  
 $Z_{out} = 50 \Omega$ , PRR = 1 MHz,  $t_w = 0.5 \mu s$ .  
 B.  $C_L$  includes probe and jig capacitance.  
 C. All diodes are 1N3064 or equivalent.  
 D. Enable G is tested with  $\bar{G}$  high;  $\bar{G}$  is tested with G low.

FIGURE 1

# TYPES AM26LS32AC, AM26LS33AC QUADRUPLE DIFFERENTIAL LINE RECEIVERS

## TYPICAL CHARACTERISTICS

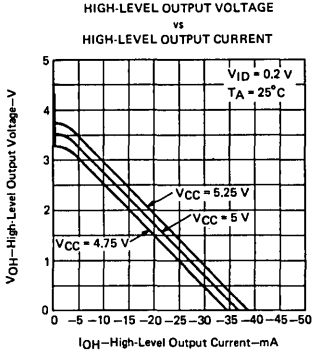

FIGURE 2

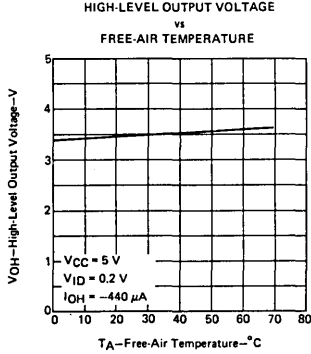

FIGURE 3

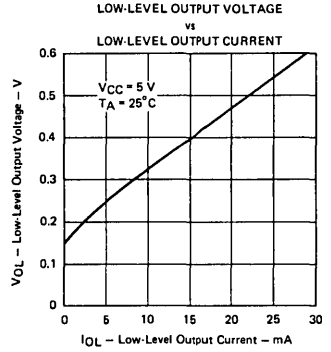

FIGURE 4

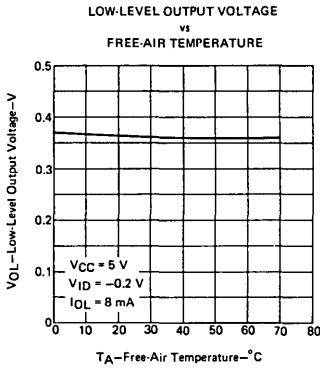

FIGURE 5

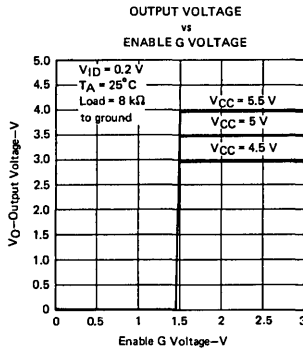

FIGURE 6

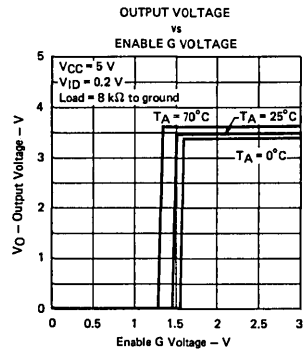

FIGURE 7

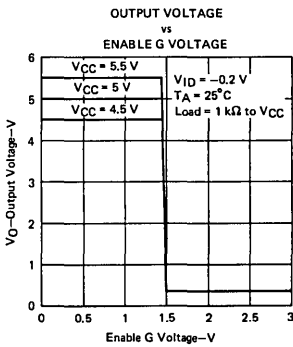

FIGURE 8

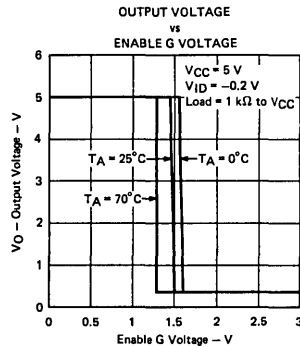

FIGURE 9

# TYPES AM26LS32AC, AM26LS33AC QUADRUPLE DIFFERENTIAL LINE RECEIVERS

## TYPICAL CHARACTERISTICS

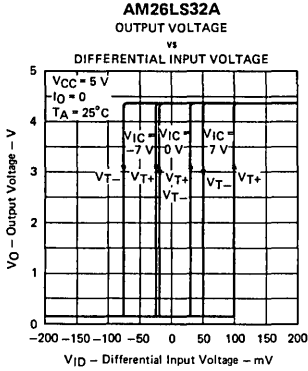

FIGURE 10

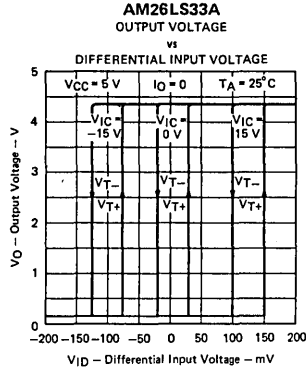

FIGURE 11

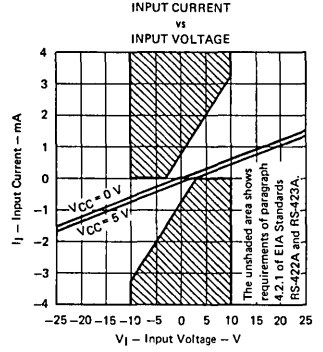

FIGURE 12

5

## TYPICAL APPLICATION



\* $R_T$  equals the characteristic impedance of the line.

FIGURE 13 - CIRCUIT WITH MULTIPLE RECEIVERS

# INTERFACE CIRCUITS

# TYPES AM26S10M, AM26S10C, AM26S11M, AM26S11C QUADRUPLE BUS TRANSCEIVERS

BULLETIN NO. DL-S 12498, JANUARY 1977 — REVISED SEPTEMBER 1980

- Schottky Circuitry<sup>†</sup> for High Speed, Typical Propagation Delay Time . . . 12 ns
- Drivers Feature Open-Collector Outputs for Party-Line (Data bus) Operation
- Driver Outputs Can Sink 100 mA at 0.8 V Maximum
- P-N-P Inputs for Minimal Input Loading
- Designed to be Interchangeable with Advanced Micro Devices AM26S10 and AM26S11

## description

The AM26S10 and AM26S11 are quadruple bus transceivers utilizing Schottky-diode-clamped transistors for high speed. The drivers feature open-collector outputs capable of sinking 100 mA at 0.8 V maximum. The driver and strobe inputs use p-n-p transistors to reduce the input loading.

The driver of the AM26S10 is inverting; the driver of the AM26S11 is noninverting. Each device has two ground connections, for improved ground current-handling capability. For proper operation, the ground pins should be tied together.

The AM26S10M and AM26S11M are characterized for operation over the full military temperature range of -55°C to 125°C. The AM26S10C and AM26S11C are characterized for operation over the temperature range of 0°C to 70°C.

AM26S10  
J OR N DUAL-IN-LINE PACKAGE  
(TOP VIEW)

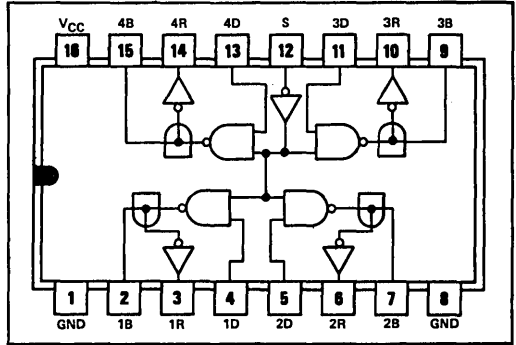

AM26S11  
J OR N DUAL-IN-LINE PACKAGE  
(TOP VIEW)

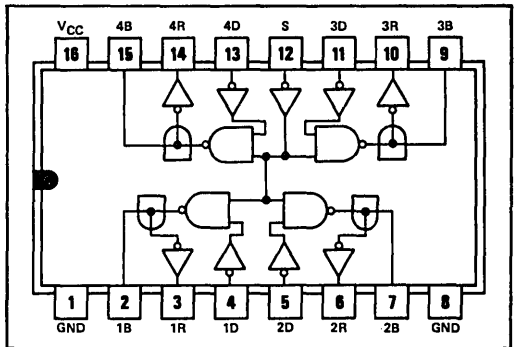

5

AM26S10  
FUNCTION TABLE  
(TRANSMITTING)

INPUTS		OUTPUTS	
S	D	B	R
L	H	L	H
L	L	H	L

AM26S11  
FUNCTION TABLE  
(TRANSMITTING)

INPUTS		OUTPUTS	
S	D	B	R
L	H	H	L
L	L	L	H

AM26S10 AND AM26S11  
FUNCTION TABLE  
(RECEIVING)

INPUTS			OUTPUT
S	B	D	R
H	H	X	L
H	L	X	H

H = high level, L = low level, X = irrelevant

Copyright © 1980 by Texas Instruments Incorporated

**TEXAS INSTRUMENTS**  
INCORPORATED  
POST OFFICE BOX 225012 • DALLAS, TEXAS 75265

†Integrated Schottky-Barrier diode-clamped transistor is patented by Texas Instruments. U. S. Patent Number 3,463,975.

# TYPES AM26S10M, AM26S10C, AM26S11M, AM26S11C QUADRUPLE BUS TRANSCEIVERS

schematic (each transceiver)

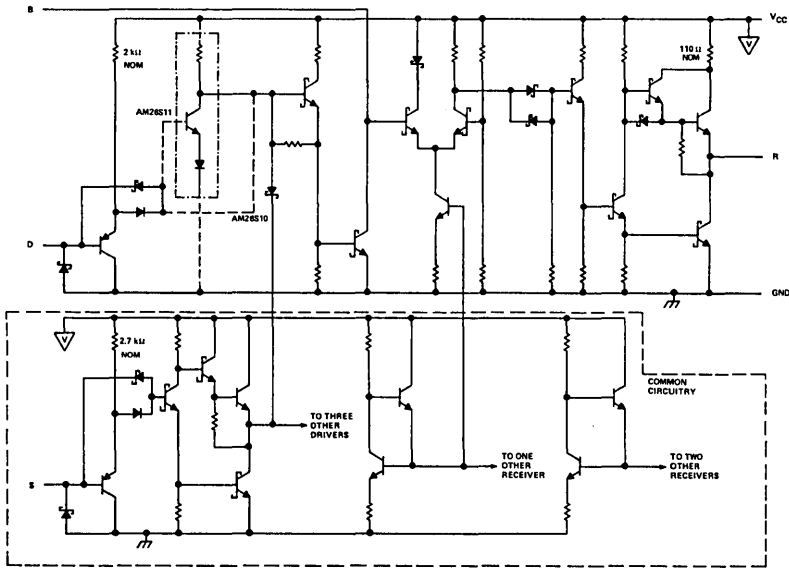

## absolute maximum ratings over operating free-air temperature range (unless otherwise noted)

Supply voltage, $V_{CC}$ (see Note 1)	.....	-0.5 V to 7 V
Driver or strobe input voltage	.....	-0.5 V to 5.5 V
Bus voltage, driver output off:	AM26S10M, AM26S11M	-0.5 V to 5.5 V
	AM26S10C, AM26S11C	-0.5 V to 5.25 V
Driver or strobe input current	.....	-30 mA to 5 mA
Driver output current	.....	200 mA
Receiver output current	.....	30 mA
Continuous total dissipation at (or below) 25°C free-air temperature (see Note 2)	.....	800 mW
Operating free-air temperature range:	AM26S10M, AM26S11M	-55°C to 125°C
	AM26S11C, AM26S11C	0°C to 70°C
Storage temperature range	.....	-65°C to 150°C
Lead temperature 1/16 inch from case for 60 seconds: J package	.....	300°C
Lead temperature 1/16 inch from case for 10 seconds: N package	.....	260°C

NOTES: 1. Voltage values are with respect to network ground terminals connected together.

2. For operation above 25°C free-air temperature, refer to Dissipation Derating Curves in the Thermal Information Section, which starts on page 21. In the J package, AM26S10M and AM26S11M chips are alloy-mounted; AM26S10C and AM26S11C chips are glass-mounted.

## recommended operating conditions

	AM26S10M AM26S11M			AM26S10C AM26S11C			UNIT
	MIN	NOM	MAX	MIN	NOM	MAX	
Supply voltage, $V_{CC}$	4.5	5	5.5	4.75	5	5.25	V
Receiver high-level output current, $I_{OH}$	-1			-1			mA
Low-level output current, $I_{OL}$	Driver		100	Receiver		100	mA
	Receiver		20	Receiver		20	mA
Operating free-air temperature, $T_A$	-55		125	0		70	°C

# TYPES AM26S10M, AM26S10C, AM26S11M, AM26S11C QUADRUPLE BUS TRANSCEIVERS

electrical characteristics over recommended operating free-air temperature range (unless otherwise noted)

PARAMETER			TEST CONDITIONS†	AM26S10M		AM26S10C		UNIT	
				AM26S11M	AM26S11C	AM26S10C	AM26S11C		
				MIN	TYP‡	MAX	MIN	TYP‡	MAX
V <sub>IH</sub>	High-level input voltage	D or S		2			2		
		B		2.4			2.25		
V <sub>IL</sub>	Low-level input voltage	D or S			0.8			0.8	
		B			1.6			1.75	
V <sub>IK</sub>	Input clamp voltage	D or S	V <sub>CC</sub> = MIN, I <sub>I</sub> = -18 mA			-1.2			-1.2
V <sub>OH</sub>	High-level output voltage	R	V <sub>CC</sub> = MIN, V <sub>IH</sub> = 2 V, V <sub>IL</sub> = V <sub>IL</sub> max, I <sub>OH</sub> = -1 mA	2.5	3.4		2.7	3.4	
V <sub>OL</sub>	Low-level output voltage	R	V <sub>CC</sub> = MIN, V <sub>IH</sub> = V <sub>IH</sub> min, V <sub>IL</sub> = 0.8 V			0.5			0.5
		B		I <sub>OL</sub> = 20 mA	0.33	0.5	0.33	0.5	
				I <sub>OL</sub> = 40 mA	0.42	0.7	0.42	0.7	
				I <sub>OL</sub> = 70 mA	0.51	0.8	0.51	0.8	
I <sub>O(off)</sub>	Off-state output current	B	V <sub>IH</sub> = 2 V, V <sub>IL</sub> = 0.8 V	V <sub>CC</sub> = MAX, V <sub>O</sub> = 0.8 V			-50		-50
				V <sub>CC</sub> = MAX, V <sub>O</sub> = 4.5 V			200		100
				V <sub>CC</sub> = 0, V <sub>O</sub> = 4.5 V			100		100
I <sub>IH</sub>	High-level input current	D	V <sub>CC</sub> = MAX, V <sub>I</sub> = 2.7 V				30		30
		S					20		20
I <sub>I</sub>	Input current at maximum input voltage	D or S	V <sub>CC</sub> = MAX, V <sub>I</sub> = 5.5 V				100		100
I <sub>IL</sub>	Low-level input current	D	V <sub>CC</sub> = MAX, V <sub>I</sub> = 0.4 V				-0.54		-0.54
		S					-0.36		-0.36
I <sub>OS</sub>	Short-circuit output current§	R	V <sub>CC</sub> = MAX	-20	-55		-18		-60
I <sub>CC</sub>	Supply current	AM26S10	V <sub>CC</sub> = MAX, Strobe at 0 V, No load,	45	70		45	70	
		AM26S11	All driver outputs low			80			80

† For conditions shown as MIN or MAX, use the appropriate value shown under recommended operating conditions.

‡ All typical values are at T<sub>A</sub> = 25°C and V<sub>CC</sub> = 5 V.

§ Not more than one output should be shorted at a time, and duration of the short-circuit should not exceed one second.

switching characteristics, V<sub>CC</sub> = 5 V, T<sub>A</sub> = 25°C

PARAMETER		FROM	TO	TEST CONDITIONS	AM26S10		AM26S11		UNIT
					MIN	TYP	MAX	MIN	
t <sub>PLH</sub>	Propagation delay time, low-to-high-level output	D	B	See Figure 1	10	15	12	19	ns
t <sub>PHL</sub>	Propagation delay time, high-to-low-level output				10	15	12	19	
t <sub>PLH</sub>	Propagation delay time, low-to-high-level output	S	B		14	18	15	20	ns
t <sub>PHL</sub>	Propagation delay time, high-to-low-level output				13	18	14	20	
t <sub>PLH</sub>	Propagation delay time, low-to-high-level output	B	R		10	15	10	15	ns
t <sub>PHL</sub>	Propagation delay time, high-to-low-level output				10	15	10	15	
t <sub>TLH</sub>	Transition time, low-to-high-level output		B		4	10	4	10	ns
t <sub>THL</sub>	Transition time, high-to-low-level output				2	4	2	4	

# TYPES AM26S10M, AM26S10C, AM26S11M, AM26S11C QUADRUPLE BUS TRANSCEIVERS

## PARAMETER MEASUREMENT INFORMATION

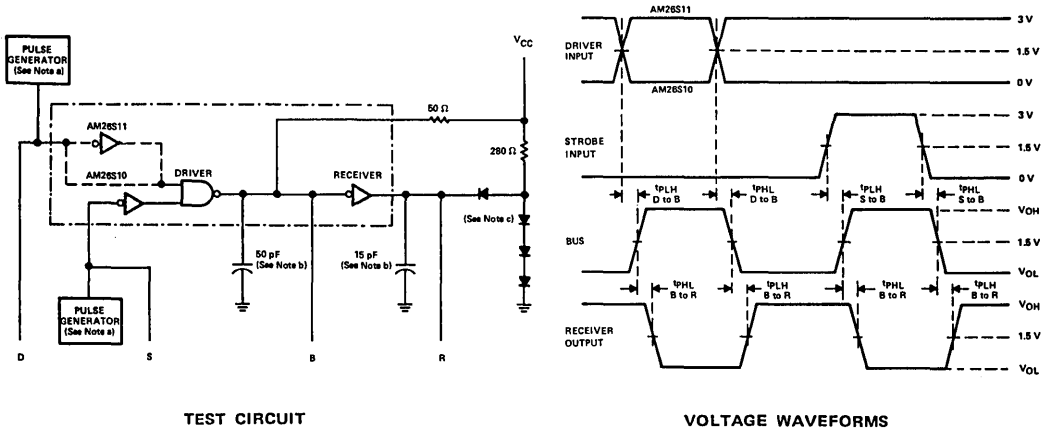

5

- NOTES: a. The pulse generators have the following characteristics:  $Z_{out} = 50 \Omega$ ,  $t_r = 10 \pm 5$  ns.  
 b. Includes probe and jig capacitance.  
 c. All diodes are 1N916 or equivalent.

FIGURE 1

## TYPICAL APPLICATION

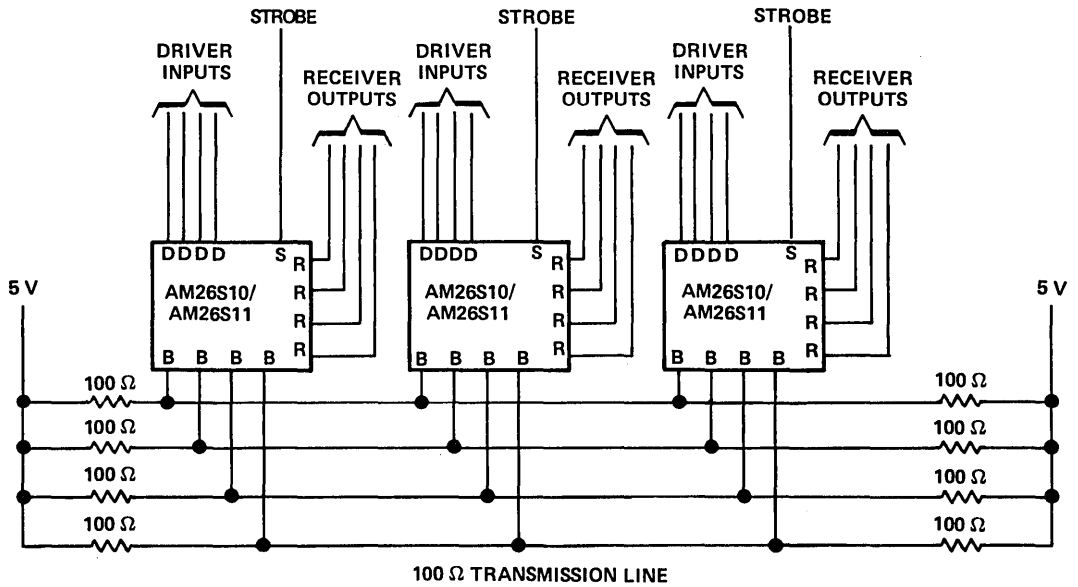

FIGURE 2—PARTY-LINE SYSTEM



# INTERFACE CIRCUITS

# TYPES DS7831, DS7832, DS8831, DS8832 LINE DRIVERS WITH 3-STATE OUTPUTS

BULLETIN NO. DL-S 12496, JANUARY 1977

- TTL Compatible
- Propagation Delay Time . . . 15 ns Typ
- Very Low Output Impedance with High Drive Capability
- 40-mA Sink and Source Capability
- Gating Control to Allow Either Single-Ended or Differential Operation
- Three-State Outputs for Party-Line (Data-Bus) Operation

DS7831, DS7832.....J PACKAGE  
DS8831, DS8832.....J OR N PACKAGE  
(TOP VIEW)

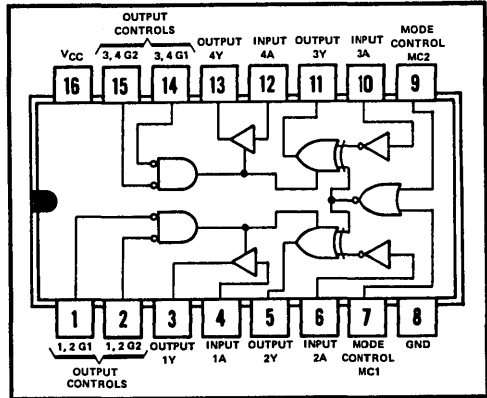

5

## description

The DS7831, DS7832, DS8831, and DS8832 can be used as either quadruple single-ended line drivers or as dual differential line drivers. This multi-mode operation and simple logic control make these devices especially useful for party-line or bus-organized systems. The DS7831 and DS8831 have output clamp diodes to  $V_{CC}$ ; the DS7832 and DS8832 do not.

For one of these circuits to operate as four independent single-ended line drivers, both mode-control pins must be low. In this mode, no signal inversion takes place between inputs and outputs. To operate as a dual differential line driver, at least one of the mode control inputs must be high. Inputs 1A and 2A should be connected together as should 3A and 4A. Then signals applied to the inputs will appear noninverted at 1Y and 4Y and inverted at 2Y and 3Y, provided the output control pins are low.

While enabled, these outputs provide good drive capability for capacitive loads, and fast transitions from both low-to-high levels and high-to-low levels.

Taking either of the associated output controls high disables the outputs. When disabled, these three-state outputs neither load nor drive a line and hundreds of these devices may be connected to a common bus line. Only one output should be enabled at a time.

The DS7831 and DS7832 are characterized for operation over the full military temperature range of  $-55^{\circ}\text{C}$  to  $125^{\circ}\text{C}$ . The DS8831 and DS8832 are characterized for operation from  $0^{\circ}\text{C}$  to  $70^{\circ}\text{C}$ .

FUNCTION TABLE

OUTPUT CONTROLS		MODE CONTROLS		DATA INPUT	OUTPUT	DATA INPUT	OUTPUT
G1	G2	MC1	MC2	1A/4A	1Y/4Y	2A/3A	2Y/3Y
L	L	L	L	H	H	H	H
L	L	L	L	L	L	L	L
L	L	X	H	H	H	H	L
L	L	H	X	L	L	L	H
H	X	X	X	X	Z	X	Z
X	H	X	X	X	Z	X	Z

H = high level, L = low level, X = irrelevant, Z = high impedance (off)

TEXAS INSTRUMENTS  
INCORPORATED

POST OFFICE BOX 226012 • DALLAS, TEXAS 75265

# TYPES DS7831, DS7832, DS8831, DS8832

## LINE DRIVERS WITH 3-STATE OUTPUTS

### absolute maximum ratings over operating free-air temperature range (unless otherwise noted)

Supply voltage, $V_{CC}$ (see Note 1)	7 V
Input voltage	5.5 V
Continuous total dissipation at (or below) 25°C free-air temperature (see Note 2): J package	1025 mW
N package	1150 mW
Operating free-air temperature range: DS78'	-55°C to 125°C
DS88'	0°C to 70°C
Storage temperature range	-65°C to 150°C
Lead temperature 1/16 inch from case for 60 seconds: J package	300°C
Lead temperature 1/16 inch from case for 10 seconds: N package	260°C

- NOTES: 1. Voltage values are with respect to network ground terminal.  
 2. For operation above 25°C free-air temperature, refer to Dissipation Derating Curves in the Thermal Information section, which starts on page 2-1. In the J package, DS7831 and DS7832 chips are alloy-mounted; DS8831 and DS8832 chips are glass-mounted.

### recommended operating conditions

	DS78'			DS88'			UNIT
	MIN	NOM	MAX	MIN	NOM	MAX	
Supply voltage, $V_{CC}$	4.5	5	5.5	4.75	5	5.25	V
Output voltage, $V_O$			5.5			5.5	V
High-level output current, $I_{OH}$			-40			-40	mA
Low-level output current, $I_{OL}$			40			40	mA
Operating free-air temperature, $T_A$	-55		125	0		70	°C

### electrical characteristics over recommended operating free-air temperature range (unless otherwise noted)

PARAMETER	TEST CONDITIONS†			MIN	TYP‡	MAX	UNIT
$V_{IH}$ High-level input voltage				2			V
$V_{IL}$ Low-level input voltage						0.8	V
$V_{IK}$ Input clamp voltage	$V_{CC} = \text{MIN}, I_I = -12 \text{ mA}$			-1		-1.5	V
$V_{OH}$ High-level output voltage	$V_{CC} = \text{MIN}, V_{IH} = 2 \text{ V}, V_{IL} = 0.8 \text{ V}$	$I_{OH} = -2 \text{ mA}$	DS7831, DS7832	2.4	3.1		V
		$I_{OH} = -5.2 \text{ mA}$	DS8831, DS8832	2.4	3.0		
		$I_{OH} = -40 \text{ mA}$		1.8	2.5		
$V_{OL}$ Low-level output voltage	$V_{CC} = \text{MIN}, V_{IH} = 2 \text{ V}, V_{IL} = 0.8 \text{ V}$	$I_{OL} = 32 \text{ mA}$		0.26	0.4		V
		$I_{OL} = 40 \text{ mA}$		0.3	0.5		
$V_{OK}$ Output clamp voltage	$V_{CC} = 5 \text{ V}, T_A = 25^\circ \text{C}$	$I_O = -12 \text{ mA}$				-1.5	V
		$I_O = 12 \text{ mA}$	DS7831, DS8831			$V_{CC} + 1.5$	
$I_{OZ}$ Off-state (high-impedance-state) output current	$V_{CC} = \text{MAX}, T_A = 25^\circ \text{C}$	$V_O = 2.4 \text{ V}$				40	$\mu\text{A}$
		$V_O = 0.4 \text{ V}$				-40	
$I_I$ Input current at maximum input voltage	$V_{CC} = \text{MAX}, V_I = 5.5 \text{ V}$					1	mA
$I_{IH}$ High-level input current	$V_{CC} = \text{MAX}, V_I = 2.4 \text{ V}$					40	$\mu\text{A}$
$I_{IL}$ Low-level input current	$V_{CC} = \text{MAX}, V_I = 0.4 \text{ V}$					-1.6	mA
$I_{OS}$ Short-circuit output current§	$V_{CC} = \text{MAX}, V_O = 0, T_A = \text{MAX}$			-40	-70	-120	mA
$I_{CC}$ Supply current	$V_{CC} = \text{MAX}$				50	90	mA

† For conditions shown as MIN or MAX, use the appropriate value specified under recommended operating conditions.

‡ All typical values are at  $T_A = 25^\circ \text{C}$  and  $V_{CC} = 5 \text{ V}$ .

§ Only one output should be shorted at a time.

# TYPES DS7831, DS7832, DS8831, DS8832 LINE DRIVERS WITH 3-STATE OUTPUTS

switching characteristics,  $V_{CC} = 5\text{ V}$ ,  $T_A = 25^\circ\text{C}$

PARAMETER <sup>†</sup>	FROM	TO	TEST CONDITIONS	MIN	TYP	MAX	UNIT
$t_{PLH}$	2A or 3A	2Y or 3Y (noninverting)	Mode controls low, See Figure 11	10	25	ns	
$t_{PHL}$				12	25		
$t_{PLH}$	2A or 3A	2Y or 3Y (inverting)	Mode controls high, See Figure 11	12	25	ns	
$t_{PHL}$				15	25		
$t_{PLH}$	1A or 4A	1Y or 4Y	See Figure 11	9	25	ns	
$t_{PHL}$				11	25		
$t_{PZH}$	G1 or G2	Any Y	$C_L = 50\text{ pF}$ , See Figure 13	12	22	ns	
$t_{PZL}$				14	27		
$t_{PHZ}$	G1 or G2	Any Y	$C_L = 5\text{ pF}$ , See Figure 13	6	12	ns	
$t_{PLZ}$				15	22		

- <sup>†</sup> $t_{PLH}$   $\equiv$  Propagation delay time, low-to-high-level output  
 $t_{PHL}$   $\equiv$  Propagation delay time, high-to-low-level output  
 $t_{PZH}$   $\equiv$  Output enable time to high level  
 $t_{PZL}$   $\equiv$  Output enable time to low level  
 $t_{PHZ}$   $\equiv$  Output disable time from high level  
 $t_{PLZ}$   $\equiv$  Output disable time from low level

schematics of inputs and outputs

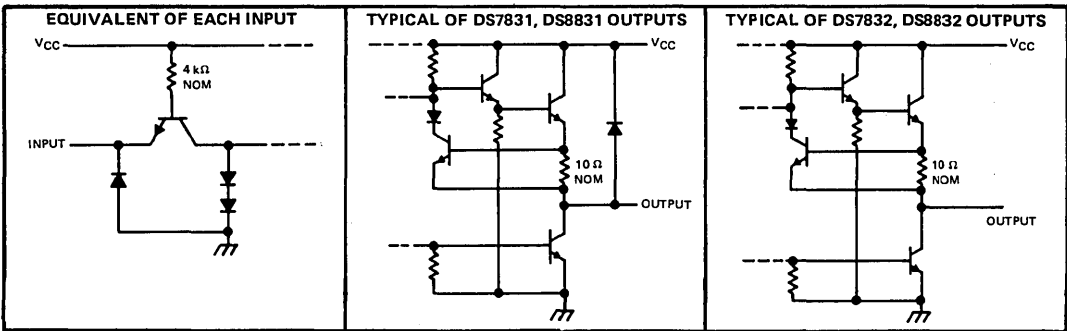

## TYPICAL CHARACTERISTICS

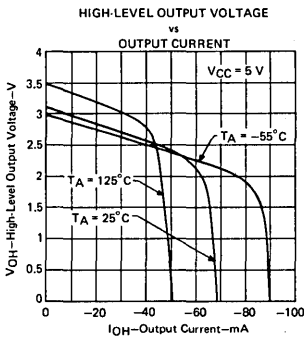

FIGURE 1

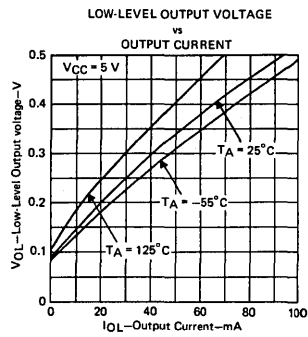

FIGURE 2

TEXAS INSTRUMENTS  
INCORPORATED

POST OFFICE BOX 225012 • DALLAS, TEXAS 75265

# TYPES DS7831, DS7832, DS8831, DS8832 LINE DRIVERS WITH 3-STATE OUTPUTS

## TYPICAL CHARACTERISTICS†

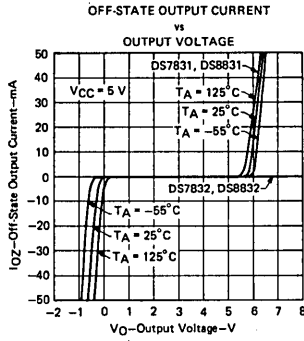

FIGURE 3

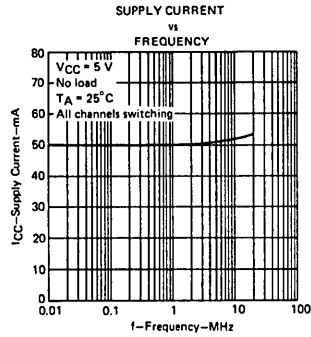

FIGURE 4

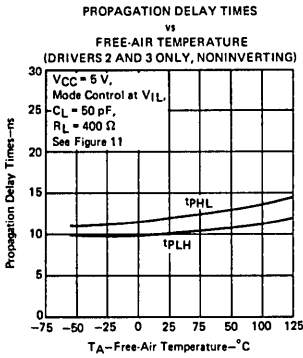

FIGURE 5

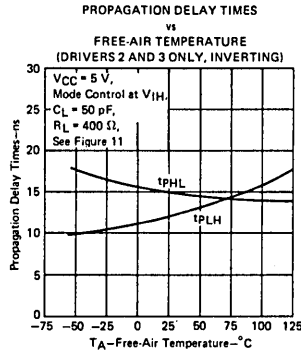

FIGURE 6

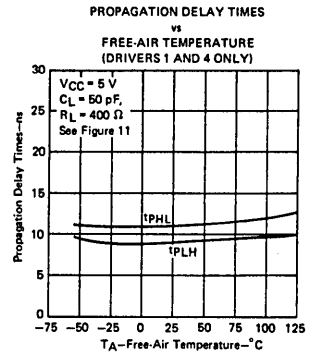

FIGURE 7

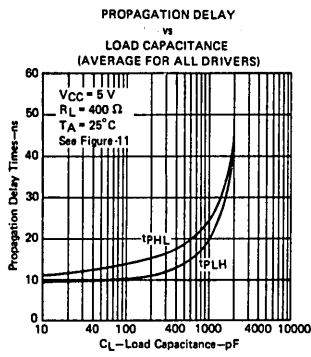

FIGURE 8

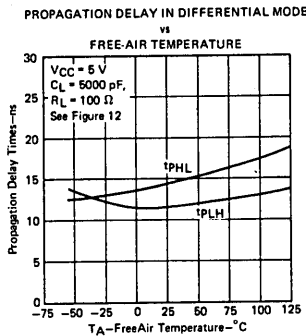

FIGURE 9

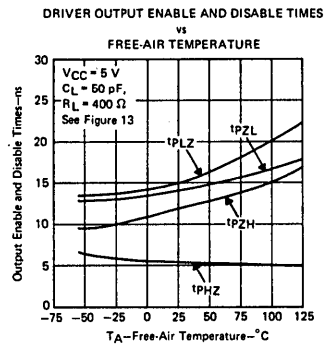

FIGURE 10

† Data for free-air temperature below 0°C and above 70°C are applicable to DS7831 and DS7832 circuits only.

# TYPES DS7831, DS7832, DS8831, DS8832 LINE DRIVERS WITH 3-STATE OUTPUTS

## PARAMETER MEASUREMENT INFORMATION

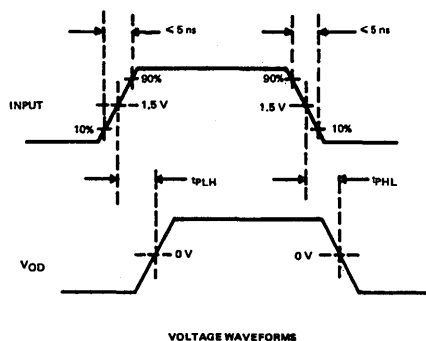
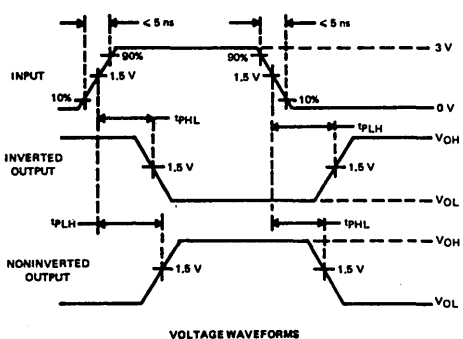
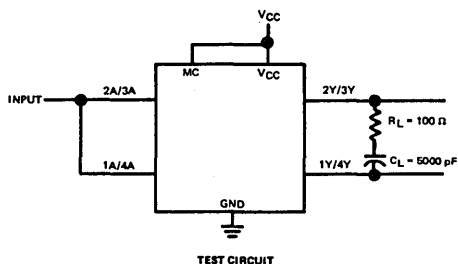
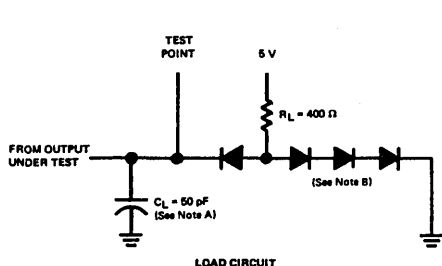

FIGURE 11— $t_{PLH}$  and  $t_{PHL}$ , SINGLE-ENDED MODE

FIGURE 12— $t_{PLH}$  and  $t_{PHL}$ , DIFFERENTIAL MODE

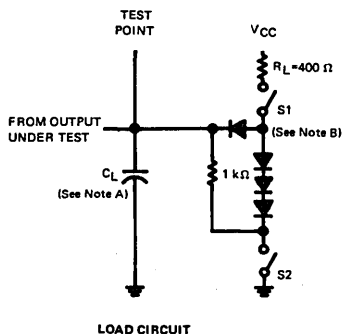
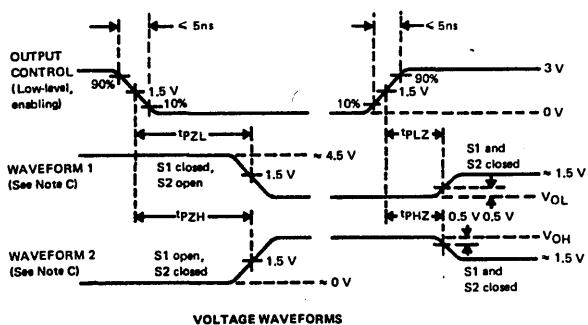

FIGURE 13—ENABLE AND DISABLE TIMES

NOTES: A.  $C_L$  includes probe and job capacitance.

B. All diodes are 1N916 or 1N3064.

C. Waveform 1 is for an output with internal conditions such that the output is low except when disabled by the output control. Waveform 2 is for an output with internal conditions such that the output is high except when disabled by the output control.

# TYPES DS7831, DS7832, DS8831, DS8832 LINE DRIVERS WITH 3-STATE OUTPUTS

## TYPICAL APPLICATION DATA

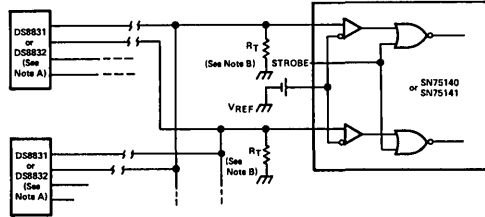

FIGURE 14—PARTY-LINE OPERATION UTILIZING THE SINGLE-ENDED CAPABILITY OF THE DEVICE

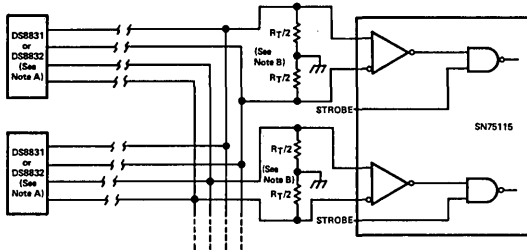

FIGURE 15—PARTY-LINE OPERATION UTILIZING THE DIFFERENTIAL CAPABILITY OF THE DEVICE

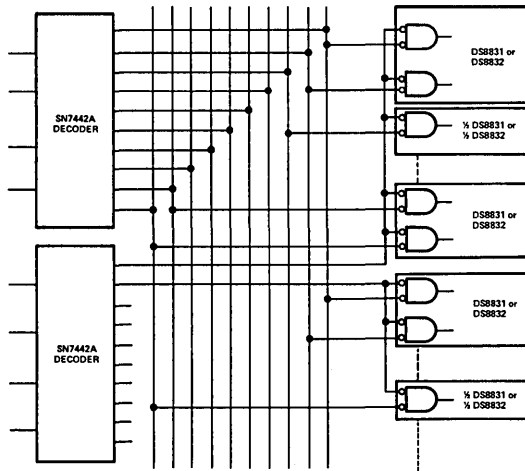

FIGURE 16—USING TWO 4-LINE-TO-10-LINE DECODERS TO CONTROL 100 DRIVER OUTPUTS

NOTES: A. One device may be driving onto the bus lines, and all other devices should be in the high-impedance state.  
B. The value of  $R_T$  should be approximately equal to the characteristic impedance of the transmission line.

# INTERFACE CIRCUITS

# TYPE MC3446 QUADRUPLE BUS TRANSCEIVER

BULLETIN NO. DL-S 12492, JANUARY 1977 — REVISED AUGUST 1977

J OR N DUAL-IN-LINE PACKAGE  
(TOP VIEW)

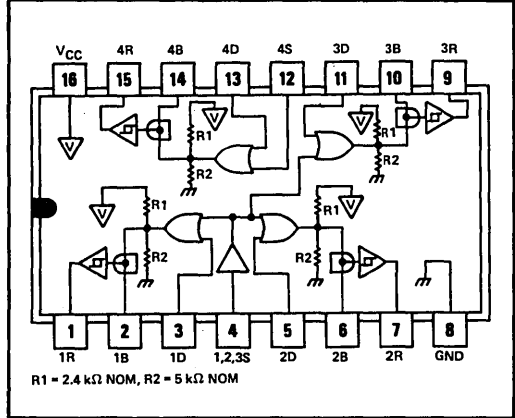

- Driver Inputs Compatible with TTL and MOS Circuitry
- Driver Outputs Stay Off During Power Up and Power Down
- Drivers Feature Open-Collector Outputs for Party-Line Operation
- Designed for Interchangeability with Motorola MC3446
- Meets IEEE Standard 488-1975

## description

These circuits are quadruple, single-ended line transceivers designed for bidirectional flow of data and instructions. The bus terminal characteristic complies with paragraph 3.5.3 of IEEE Standard 488 (see Figure 3). Each driver output is tied to the junction of an internal voltage divider that sets the no-load output voltage and provides bus termination. The driver outputs are guaranteed to be "off" during power up and power down if either input is high. The receivers feature 950 millivolts typical hysteresis for noise immunity.

The MC3446 is characterized for operation from 0°C to 70°C.

FUNCTION TABLE  
(TRANSMITTING)

INPUTS		OUTPUT	
S	D	B	R
L	H	H	H
L	L	L	L

FUNCTION TABLE  
(RECEIVING)

INPUTS			OUTPUT
S	B	D	R
H	H	X	H
H	L	X	L

## schematics of inputs and outputs

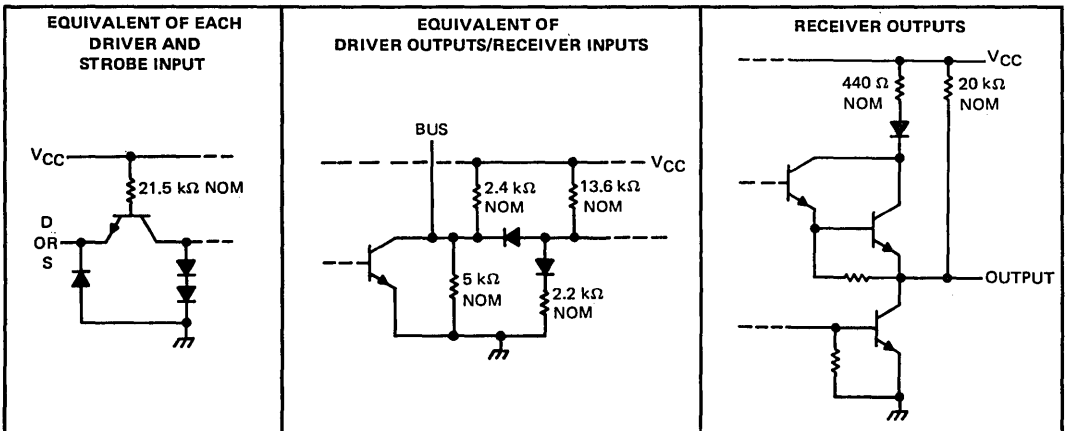

TEXAS INSTRUMENTS  
INCORPORATED

POST OFFICE BOX 225012 • DALLAS, TEXAS 75265

# TYPE MC3446

## QUADRUPLE BUS TRANSCEIVER

### absolute maximum ratings over operating free-air temperature range (unless otherwise noted)

Supply voltage, $V_{CC}$ (see Note 1)	7 V
Input voltage	5.5 V
Driver output current	150 mA
Continuous total dissipation at (or below) 25°C free-air temperature (see Note 2)	830 mW
Operating free-air temperature range	0°C to 70°C
Storage temperature range	-65°C to 150°C
Lead temperature 1/16 inch from case for 60 seconds: J Package	300°C
Lead temperature 1/16 inch from case for 10 seconds: N Package	260°C

- NOTES: 1. Voltage values are with respect to network ground terminal.  
 2. For operation above 25°C free-air temperature, refer to Dissipation Derating Curves in the Thermal Information section, which starts on page 2-1. In the J package, MC3446 chips are glass-mounted.

### recommended operating conditions

		MIN	NOM	MAX	UNIT
Supply voltage, $V_{CC}$		4.75	5	5.25	V
High-level output current, $I_{OH}$	Receiver			-0.4	mA
	Driver			48	
Low-level output current, $I_{OL}$	Driver			8	mA
	Receiver				
Operating free-air temperature, $T_A$		0		70	°C

### electrical characteristics over recommended ranges of $V_{CC}$ and operating free-air temperature (unless otherwise noted)

PARAMETER			TEST CONDITIONS	MIN	TYP†	MAX	UNIT
$V_{IH}$	High-level input voltage	D or S		2			V
$V_{IL}$	Low-level input voltage	D or S				0.8	V
$V_{IK}$	Input clamp voltage	D or S	$I_I = -12$ mA			-1.5	V
$V_{T+}$	Positive-going input threshold voltage	B		1.5	1.8	2	V
$V_{T-}$	Negative-going input threshold voltage	B		0.6	0.85	1.1	V
$V_{T+} - V_{T-}$	Input hysteresis	B		400	950		mV
$V_{OH}$	High-level output voltage	B	$V_{IH} = 2.4$ V, $I_{OH} = 0$	2.5	3.3	3.7	V
		R	$V_{IH} = 2$ V, $I_{OH} = -400$ $\mu$ A	2.4			
$V_{OL}$	Low-level output voltage	B	$V_{IL} = 0.8$ V, $I_{OL} = 48$ mA			0.4	V
		R	$V_{IL} = 0.8$ V, $I_{OL} = 8$ mA			0.4	
$I_O$ (bus)	Bus current	B	$V_{IH} = 2.4$ V, $V_O = 5.5$ V			2.5	mA
			$V_{IH} = 2.4$ V, $V_O = 5$ V	0.7			
			$V_{IH} = 2.4$ V, $V_O = 0.4$ V	-1.3		-3.2	
$V_{OK}$	Output clamp voltage	B	$I_O = -12$ mA			-1.5	V
$I_I$	Input current at maximum input voltage	D or S	$V_I = 5.5$ V			1	mA
$I_{IH}$	High-level input current	D or S	$V_{IH} = 2.4$ V		5	20	$\mu$ A
$I_{IL}$	Low-level input current	D or S	$V_{CC} = 5$ V, $V_{IL} = 0.4$ V, $T_A = 25^\circ$ C		0.2	0.36	mA
$I_{OS}$	Short-circuit output current	R	$V_{IH} = 2$ V		4	14	mA
$I_{CCH}$	Supply current, all outputs high		No load		10	19	mA
$I_{CCL}$	Supply current, all outputs low		No load		32	39	mA

†All typical values are at  $V_{CC} = 5$  V,  $T_A = 25^\circ$ C.



# TYPE MC3446 QUADRUPLE BUS TRANSCEIVER

switching characteristics,  $V_{CC} = 5\text{ V}$ ,  $T_A = 25^\circ\text{C}$

PARAMETER	FROM	TO	TEST CONDITIONS	MIN	MAX	UNIT
$t_{PLH}$ Propagation delay time, low-to-high-level output	D	B	See Figure 1		40	ns
$t_{PHL}$ Propagation delay time, high-to-low-level output					50	
$t_{PLH}$ Propagation delay time, low-to-high-level output	S	B			50	ns
$t_{PHL}$ Propagation delay time, high-to-low-level output					50	
$t_{PLH}$ Propagation delay time, low-to-high-level output	B	R	See Figure 2		50	ns
$t_{PHL}$ Propagation delay time, high-to-low-level output					40	

## PARAMETER MEASUREMENT INFORMATION

5

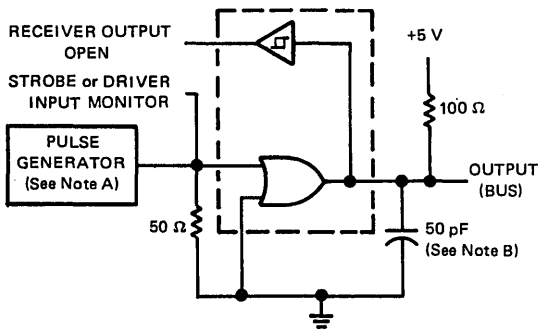

TEST CIRCUIT

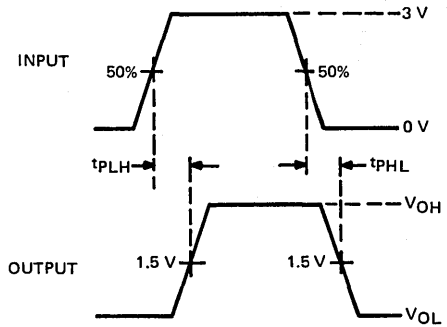

VOLTAGE WAVEFORMS

NOTES: A. The input pulse is supplied by a generator having the following characteristics:  $t_w = 100\text{ ns}$ ,  $\text{PRR} = 1\text{ MHz}$ ,  $t_r < 10\text{ ns}$ ,  $t_f < 10\text{ ns}$ ,  $Z_{out} \approx 50\ \Omega$ .  
 B. This value includes probe and jig capacitance.

FIGURE 1

# TYPE MC3446 QUADRUPLE BUS TRANSCEIVER

## PARAMETER MEASUREMENT INFORMATION

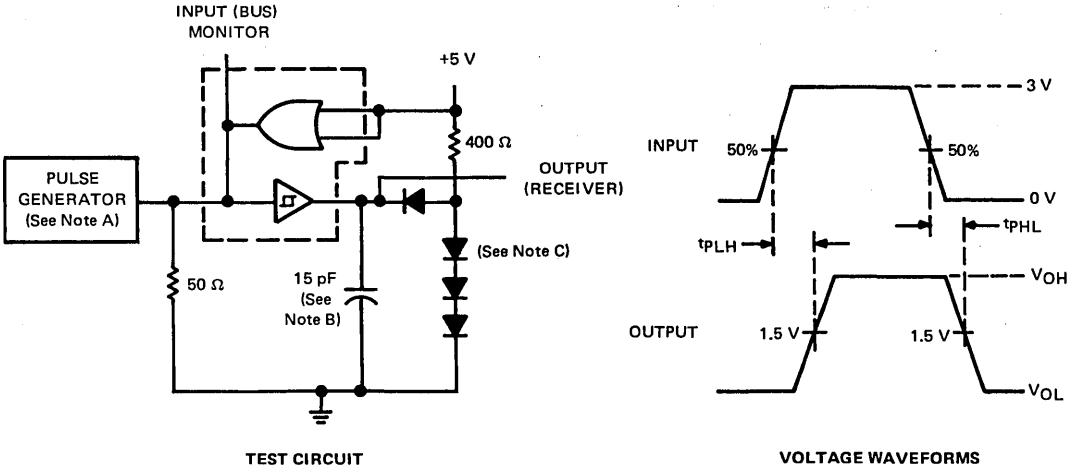

NOTES: A. The input pulse is supplied by a generator having the following characteristics:  $t_w = 100$  ns, PRR = 1 MHz,  $t_r \leq 10$  ns,  $t_f \leq 10$  ns,  $Z_{out} \approx 50 \Omega$ .  
 B. This value includes probe and jig capacitance.  
 C. All diodes are 1N916 or 1N3064.

FIGURE 2

## TYPICAL CHARACTERISTICS

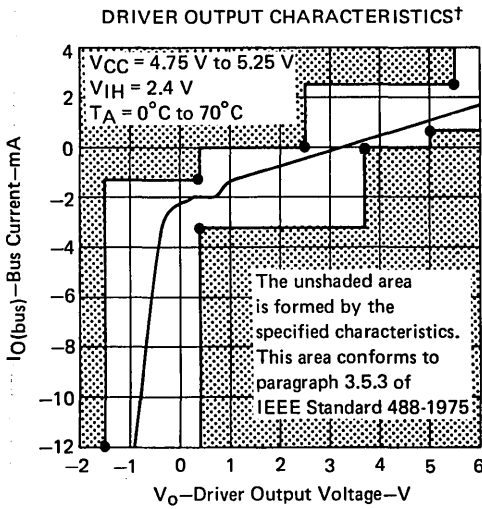

FIGURE 3

† Conditions for typical curve are  $V_{CC} = 5$  V,  $T_A = 25^\circ\text{C}$ .

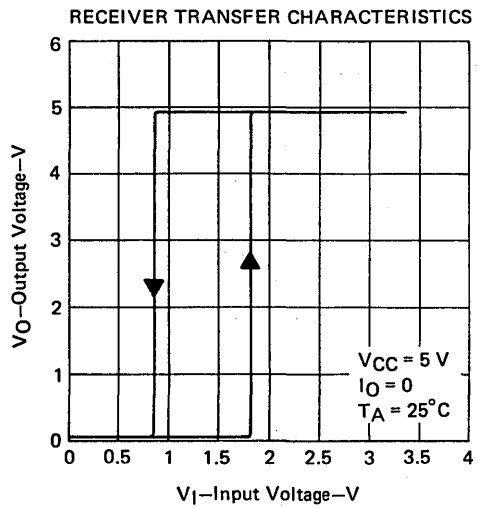

FIGURE 4

# INTERFACE CIRCUITS

# TYPE MC3486 QUADRUPLE LINE RECEIVER WITH 3-STATE OUTPUT

BULLETIN NO. DL-S 12748, JUNE 1980

- Meets EIA Standards RS-422A and RS-423A and Federal Standards 1020 and 1030
- Three-State, TTL-Compatible Outputs
- Fast Transition Times
- Operates From Single 5-Volt Supply
- Designed to be Interchangeable with Motorola MC3486

### description

The MC3486 is a monolithic quadruple differential line receiver designed to meet the specifications of EIA Standards RS-422A and RS-423A and Federal Standards 1020 and 1030. The MC3486 offers four independent differential-input line receivers that have TTL-compatible outputs. The outputs utilize three-state circuitry to provide a high-impedance state at any output when the appropriate output enable is at a low logic level.

The MC3486 is designed for optimum performance when used with the MC3487 quadruple differential line driver. It is supplied in a 16-pin dual-in-line package and operates from a single 5-volt supply.

The MC3486 is characterized for operation from 0°C to 70°C.

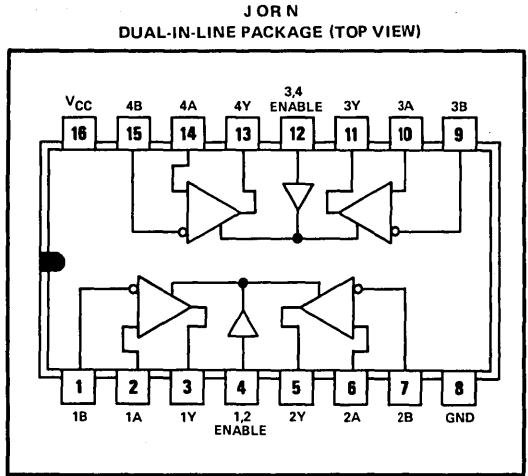

FUNCTION TABLE (EACH RECEIVER)

DIFFERENTIAL INPUTS A-B	ENABLE	OUTPUT Y
$V_{ID} > 0.2 \text{ V}$	H	H
$-0.2 \text{ V} < V_{ID} < 0.2 \text{ V}$	H	?
$V_{ID} < -0.2 \text{ V}$	H	L
Irrelevant	L	Z

H = high level, L = low level, Z = high-impedance (off),  
? = Indeterminate

### schematics of inputs and outputs

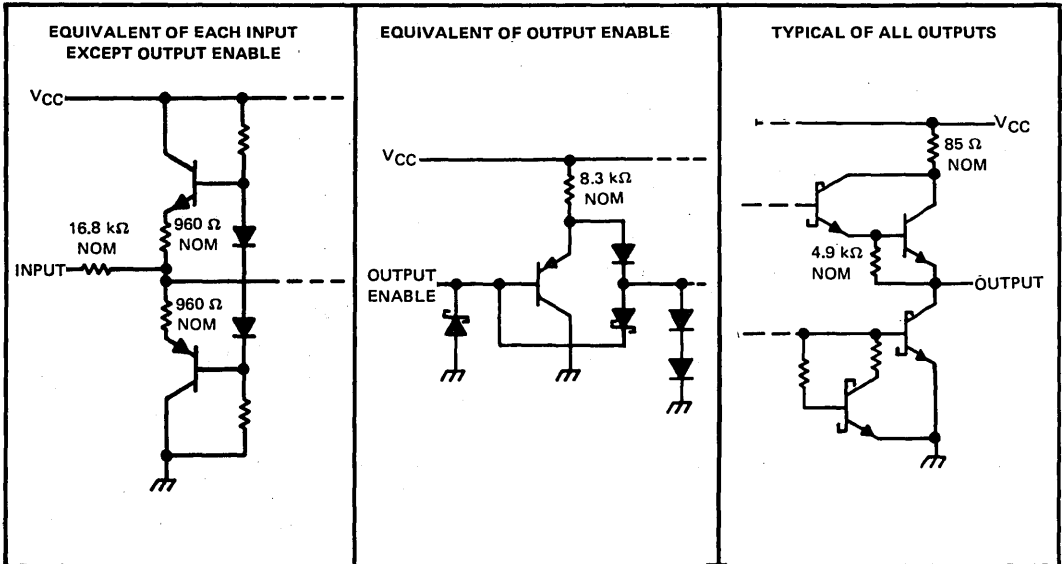

Copyright © 1980 by Texas Instruments Incorporated

**TEXAS INSTRUMENTS**  
INCORPORATED

POST OFFICE BOX 225012 • DALLAS, TEXAS 75265

# TYPE MC3486

## QUADRUPLE LINE RECEIVER WITH 3-STATE OUTPUT

absolute maximum ratings over operating free-air temperature range (unless otherwise noted)

Supply voltage, $V_{CC}$ (see Note 1)	8 V
Input voltage, A or B inputs	$\pm 15$ V
Differential input voltage (see Note 2)	$\pm 25$ V
Enable input voltage	8 V
Low-level output current	50 mA
Continuous total dissipation at (or below) 25°C free-air temperature (see Note 3): J Package	1025 mW
N Package	1150 mW
Operating free-air temperature range	0°C to 70°C
Storage temperature range	-65°C to 150°C
Lead temperature 1/16 inch (1,6 mm) from case for 60 seconds: J Package	300°C
Lead temperature 1/16 inch (1,6 mm) from case for 10 seconds: N Package	260°C

- NOTES: 1. All voltage values, except differential-input voltage, are with respect to network ground terminal.  
 2. Differential-input voltage is measured at the noninverting input with respect to the corresponding inverting input.  
 3. For operation above 25°C free-air temperature, derate the J package at the rate of 8.2 mW/°C and the N package at the rate of 9.2 mW/°C.

recommended operating conditions

	MIN	NOM	MAX	UNIT
Supply voltage, $V_{CC}$	4.75	5	5.25	V
Common-mode input voltage, $V_{IC}$			$\pm 7$	V
Differential input voltage, $V_{ID}$			$\pm 6$	V
Operating free-air temperature, $T_A$	0		70	°C

electrical characteristics over recommended ranges of common-mode input voltage, supply voltage, and operating free-air temperature (unless otherwise noted)

PARAMETER	TEST CONDITIONS	MIN	MAX	UNIT
$V_{TH}$ Differential-input high-threshold voltage	$V_O = 2.7$ V, $I_O = -0.4$ mA		0.2	V
$V_{TL}$ Differential-input low-threshold voltage	$V_O = 0.5$ V, $I_O = 8$ mA	-0.2†		V
$V_{IH}$ High-level enable input voltage		2		V
$V_{IL}$ Low-level enable input voltage			0.8	V
$V_{IK}$ Enable-input clamp voltage	$I_I = -10$ mA		-1.5	V
$V_{OH}$ High-level output voltage	$V_{ID}^* = 0.4$ V, $I_O = -0.4$ mA, See Note 4 and Figure 1	2.7		V
$V_{OL}$ Low-level output voltage	$V_{ID}^* = -0.4$ V, $I_O = 8$ mA, See Note 4 and Figure 1		0.5	V
$I_{OZ}$ High-impedance-state output current	$V_{IL} = 0.8$ V, $V_{ID} = -3$ V, $V_O = 2.7$ V		40	$\mu$ A
	$V_{IL} = 0.8$ V, $V_{ID} = 3$ V, $V_O = 0.5$ V		-40	
$I_{IB}$ Differential-input bias current	$V_{CC} = 0$ V or 5.25 V, Other inputs at 0 V	$V_I = -10$ V	-3.25	mA
		$V_I = -3$ V	-1.5	
		$V_I = 3$ V	1.5	
		$V_I = 10$ V	3.25	
$I_{IH}$ High-level enable input current	$V_I = 5.25$ V		100	$\mu$ A
	$V_I = 2.7$ V		20	
$I_{IL}$ Low-level enable input current	$V_I = 0.5$ V		-100	$\mu$ A
$I_{OS}$ Short-circuit output current	$V_{ID} = 3$ V, $V_O = 0$ V, See Note 5	-15	-100	mA
$I_{CC}$ Supply current	$V_{IL} = 0$ V		85	mA

† The algebraic convention, where the least-positive (most-negative) limit is designated as minimum, is used in this data sheet for threshold voltages only.

- NOTES: 4. Refer to EIA Standards RS-422A and RS-423A for exact conditions.  
 5. Only one output at a time should be shorted.

# TYPE MC3486

## QUADRUPLE LINE RECEIVER WITH 3-STATE OUTPUT

switching characteristics,  $V_{CC} = 5\text{ V}$ ,  $T_A = 25^\circ\text{C}$

PARAMETER	TEST CONDITIONS	MIN	TYP	MAX	UNIT
$t_{PHL}$	Propagation delay time, high-to-low-level output		28	35	ns
$t_{PLH}$	Propagation delay time, low-to-high-level output		27	30	ns
$t_{PZH}$	Output enable time to high level		13	30	ns
$t_{PZL}$	Output enable time to low level		20	30	ns
$t_{PHZ}$	Output disable time from high level		26	35	ns
$t_{PLZ}$	Output disable time from low level		27	35	ns

### PARAMETER MEASUREMENT INFORMATION

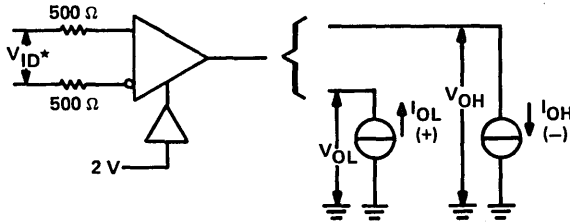
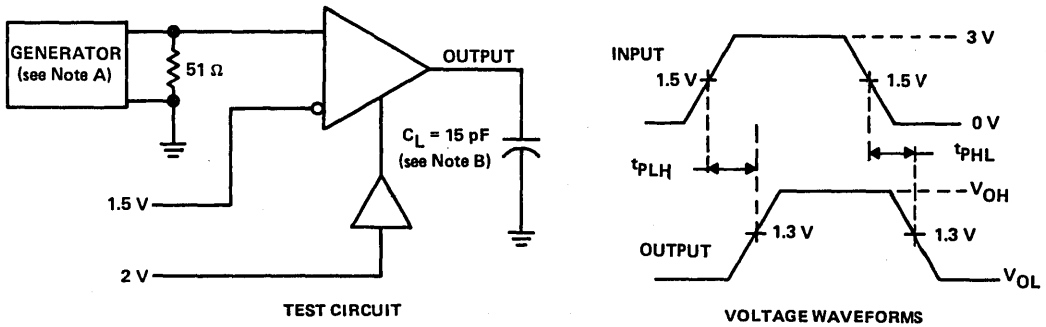

FIGURE 1— $V_{OH}$ ,  $V_{OL}$



NOTES: A: The input pulse is supplied by a generator having the following characteristics: PRR = 1 MHz, duty cycle = 50%,  $t_r = t_f = 6\text{ ns}$ .  
 B:  $C_L$  includes probe and stray capacitance.

FIGURE 2—PROPAGATION DELAY TIMES

# TYPE MC3486 QUADRUPLE LINE RECEIVER WITH 3-STATE OUTPUT

## PARAMETER MEASUREMENT INFORMATION

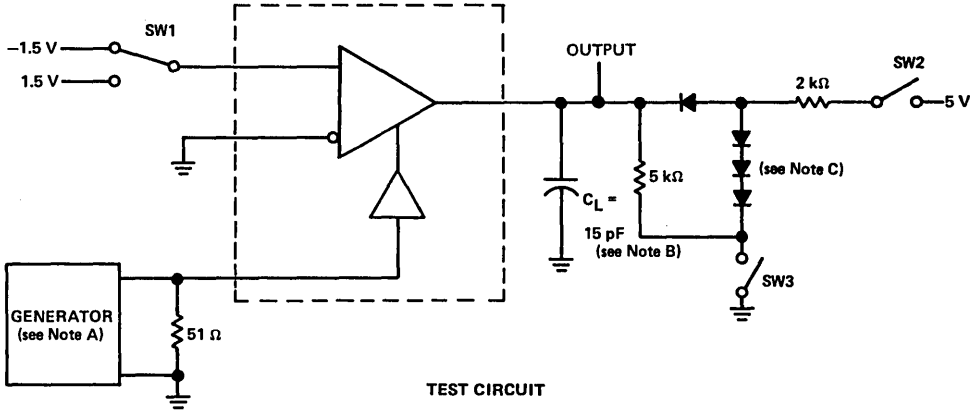

5

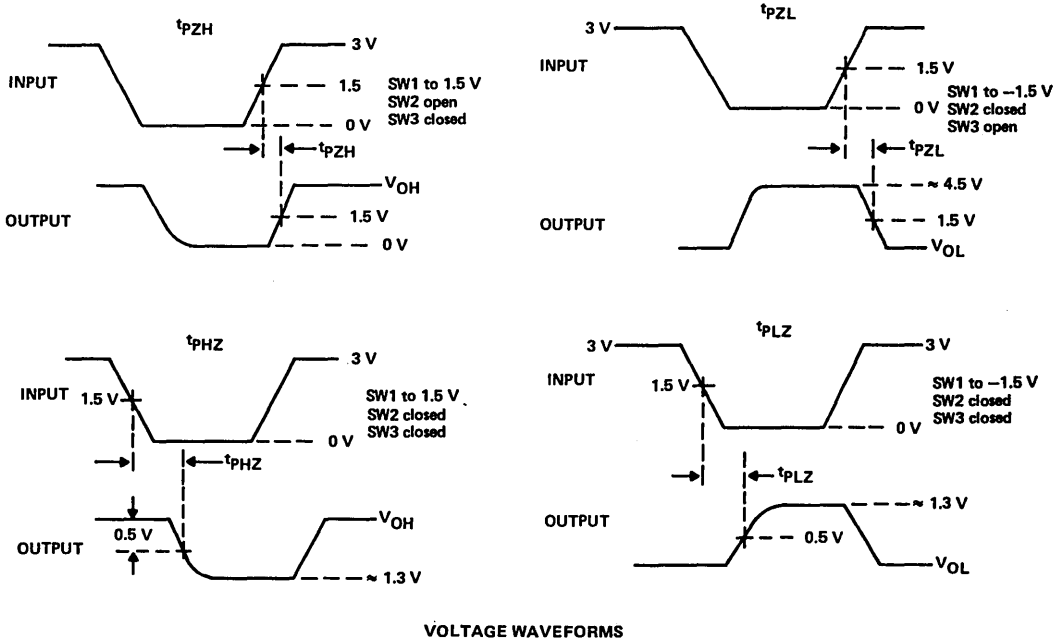

FIGURE 3—ENABLE AND DISABLE TIMES

NOTES: A. The input pulse is supplied by a generator having the following characteristics: PRR = 1 MHz, duty cycle ≈ 50%,  $t_r = t_f = 6$  ns.  
 B.  $C_L$  includes probe and stray capacitance  
 C. All diodes are 1N916 or equivalent.

# INTERFACE CIRCUITS

# TYPE MC3487 QUADRUPLER DIFFERENTIAL LINE DRIVER WITH 3-STATE OUTPUTS

BULLETIN NO. DL-S 12749, MAY 1980

- Meets EIA Standard RS-422A and Federal Standard 1020
- Three-State, TTL-Compatible Outputs
- Fast Transition Times
- High-Impedance Inputs
- Single 5-Volt Supply
- Power-Up and Power-Down Protection
- Designed To Be Interchangeable with Motorola MC3487

## description

The MC3487 offers four independent differential line drivers designed to meet the specifications of EIA Standard RS-422A and Federal Standard 1020. Each driver has a TTL-compatible input buffered to reduce current and minimize loading.

The driver outputs utilize 3-state circuitry to provide high-impedance states at any pair of differential outputs when the appropriate output enable is at a logic low level. Internal circuitry is provided to ensure a high-impedance state at the differential outputs during power-up and power-down transition times, provided the output enable is low. The outputs are capable of source or sink currents of 48 milliamperes.

The MC3487 is designed for optimum performance when used with the MC3486 quadruple line receiver. It is supplied in a 16-pin dual-in-line package and operates from a single 5-volt supply.

The MC3487 is characterized for operation from 0°C to 70°C.

JORN  
DUAL-IN-LINE PACKAGE (TOP VIEW)

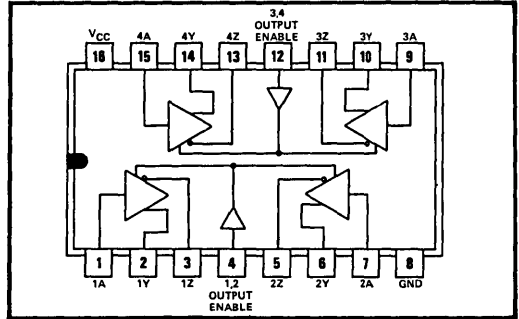

FUNCTION TABLE (EACH DRIVER)

INPUT	OUTPUT ENABLE	OUTPUTS	
		Y	Z
H	H	H	L
L	H	L	H
X	L	High-Impedance	High-Impedance

H = TTL high level      X = irrelevant  
L = TTL low level

5

## schematics of inputs and outputs

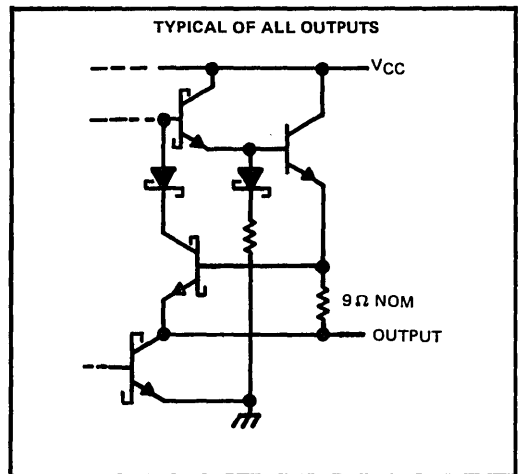
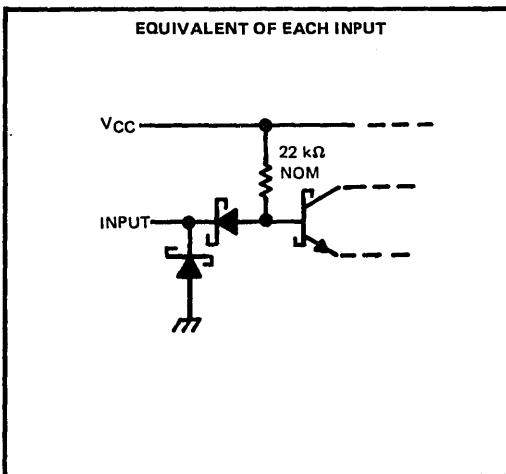

Copyright © 1980 by Texas Instruments Incorporated

TEXAS INSTRUMENTS  
INCORPORATED

POST OFFICE BOX 225012 • DALLAS, TEXAS 75265

5-39

# TYPE MC3487 QUADRUPLE DIFFERENTIAL LINE DRIVER WITH 3-STATE OUTPUTS

absolute maximum ratings over operating free-air temperature range (unless otherwise noted)

Supply voltage, $V_{CC}$ (see Note 1)	8 V
Input voltage	5.5 V
Continuous total dissipation at (or below) 25°C free-air temperature (see Note 2):	
J package	1025 mW
N package	1150 mW
Operating free-air temperature range	0°C to 70°C
Storage temperature range	-65°C to 150°C
Lead temperature 1/16 inch (1,6 mm) from case for 60 seconds: J package	300°C
Lead temperature 1/16 inch (1,6 mm) from case for 10 seconds: N package	260°C

NOTES: 1. All voltage values, except differential output voltage  $V_{OD}$ , are with respect to the network ground terminal.  
2. For operation above 25°C free-air temperature, derate the J package at the rate of 8.2 mW/°C and the N package at the rate of 9.2 mW/°C.

recommended operating conditions

	MIN	NOM	MAX	UNIT
Supply voltage, $V_{CC}$	4.75	5	5.25	V
Operating free-air temperature, $T_A$	0		70	°C

electrical characteristics over recommended ranges of supply voltage and operating free-air temperature (unless otherwise noted)

PARAMETER	TEST CONDITIONS	MIN	MAX	UNIT	
$V_{IH}$	High-level input voltage	2		V	
$V_{IL}$	Low-level input voltage		0.8	V	
$V_{IK}$	Input clamp voltage	$I_I = -18$ mA	-1.5	V	
$V_{OH}$	High-level output voltage	$V_{IL} = 0.8$ V, $V_{IH} = 2$ V	$I_{OH} = -20$ mA $I_{OH} = -48$ mA	2.5 2	V
$V_{OL}$	Low-level output voltage	$V_{IL} = 0.8$ V, $V_{IH} = 2$ V,	$I_{OL} = 48$ mA	0.5	V
$ V_{OD} $	Differential output voltage	$R_L = 100$ $\Omega$ , See Figure 1	2	V	
$\Delta V_{OD} $	Change in magnitude of differential output voltage <sup>†</sup>	$R_L = 100$ $\Omega$ , See Figure 1		$\pm 0.4$	V
$V_{OC}$	Common-mode output voltage <sup>‡</sup>	$R_L = 100$ $\Omega$ , See Figure 1	3	V	
$\Delta V_{OC} $	Change in magnitude of common-mode output voltage <sup>‡</sup>	$R_L = 100$ $\Omega$ , See Figure 1		$\pm 0.4$	V
$I_O$	Output current with power off	$V_{CC} = 0$ V	$V_O = 6$ V $V_O = -0.25$ V	100 -100	$\mu$ A
$I_{OZ}$	High-impedance-state output current	Output enables at 0.8 V	$V_O = 2.7$ V $V_O = 0.5$ V	100 -100	$\mu$ A
$I_I$	Input current at maximum input voltage	$V_I = 5.5$ V		100	$\mu$ A
$I_{IH}$	High-level input current	$V_I = 2.7$ V		50	$\mu$ A
$I_{IL}$	Low-level input current	$V_I = 0.5$ V		-400	$\mu$ A
$I_{OS}$	Short-circuit output current <sup>§</sup>	$V_I = 2$ V		-40 -140	mA
$I_{CC}$	Supply current (all drivers)	Inputs grounded, No load Output enables at 2 V		105 85	mA

<sup>†</sup> $\Delta|V_{OD}|$  and  $\Delta|V_{OC}|$  are the changes in magnitude of  $V_{OD}$  and  $V_{OC}$ , respectively, that occur when the input is changed from a high level to a low level.

<sup>‡</sup>In EIA Standard RS-422A,  $V_{OC}$ , which is the average of the two output voltages with respect to ground, is called output offset voltage,  $V_{OS}$ .

<sup>§</sup>Only one output at a time should be shorted and duration of the short-circuit should not exceed one second.



# TYPE MC3487 QUADRUPLE DIFFERENTIAL LINE DRIVER WITH 3-STATE OUTPUTS

switching characteristics,  $V_{CC} = 5\text{ V}$ ,  $T_A = 25^\circ\text{C}$

PARAMETER	TEST CONDITION	MIN	MAX	UNIT
$t_{PLH}$ Propagation delay time, low-to-high-level output	$C_L = 15\text{ pF}$ , See Figure 2		20	ns
$t_{PHL}$ Propagation delay time, high-to-low-level output			20	ns
Skew			6	ns
$t_{TD}$ Differential-output transition time	$C_L = 15\text{ pF}$ , See Figure 3		20	ns
$t_{PZH}$ Output enable time to high level	$C_L = 50\text{ pF}$ , See Figure 4		30	ns
$t_{PZL}$ Output enable time to low level			30	ns
$t_{PHZ}$ Output disable time from high level			25	ns
$t_{PLZ}$ Output disable time from low level			25	ns

## PARAMETER MEASUREMENT INFORMATION

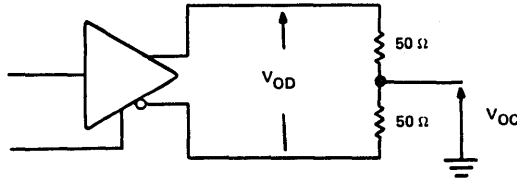
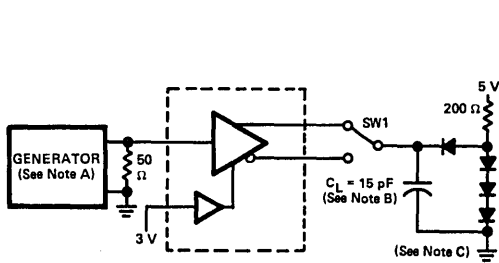
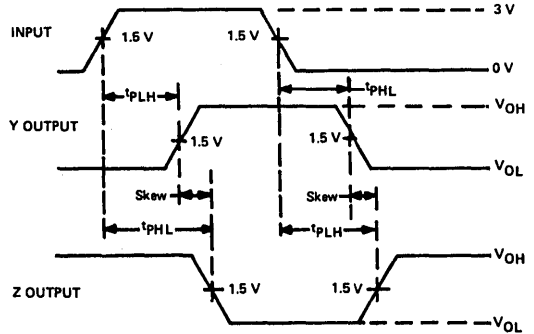

FIGURE 1—DIFFERENTIAL AND COMMON-MODE OUTPUT VOLTAGES



TEST CIRCUIT



VOLTAGE WAVEFORM

- NOTES: A. The input pulse is supplied by a generator having the following characteristics:  $t_r < 5\text{ ns}$ ,  $t_f < 5\text{ ns}$ ,  $PRR = 1\text{ MHz}$ , duty cycle = 50%,  $Z_o = 50\ \Omega$ .  
 B.  $C_L$  includes probe and stray capacitance.  
 C. All diodes are IN916 or IN3064.

FIGURE 2—PROPAGATION DELAY TIMES

# TYPE MC3487 QUADRUPLE DIFFERENTIAL LINE DRIVER WITH 3-STATE OUTPUTS

## PARAMETER MEASUREMENT INFORMATION

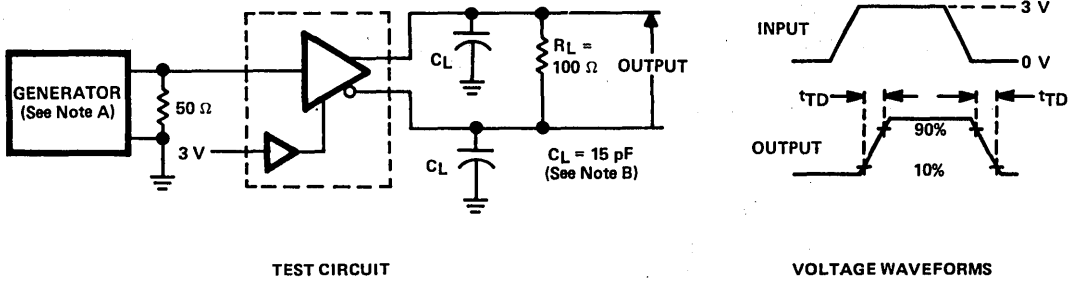

FIGURE 3—DIFFERENTIAL-OUTPUT TRANSITION TIMES

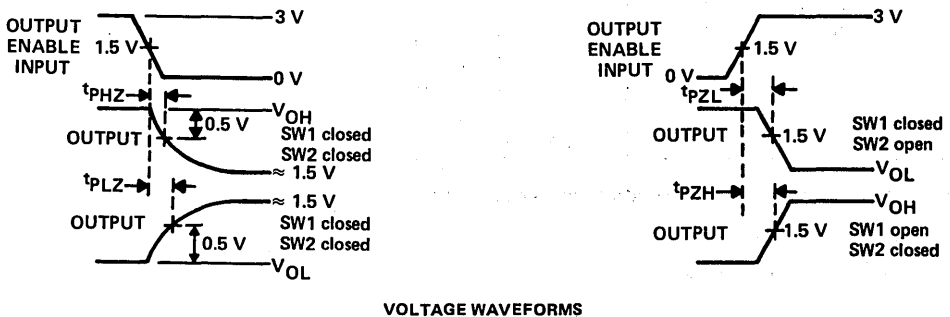
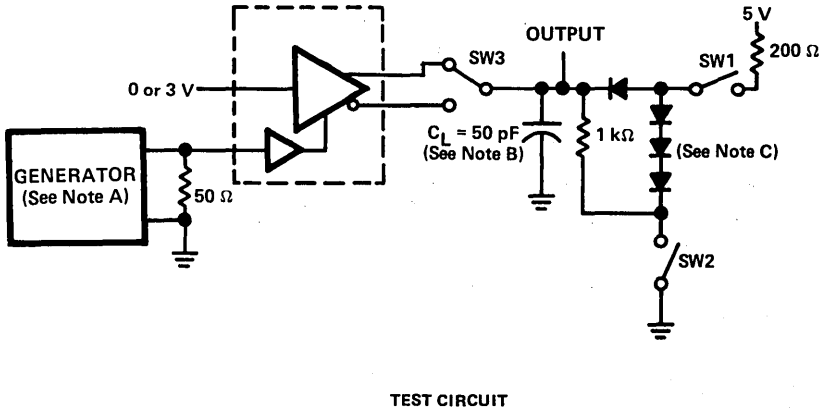

FIGURE 4—DRIVER ENABLE AND DISABLE TIMES

- NOTES: A. The Input pulse is supplied by a generator having the following characteristics:  $t_r < 5$  ns,  $t_f < 5$  ns, PRR = 1 MHz, duty cycle = 50%,  $Z_o = 50 \Omega$ .  
 B.  $C_L$  includes probe and stray capacitance.  
 C. All diodes are IN916 or IN3064.

# INTERFACE CIRCUITS

# TYPES N8T26, N8T26A QUADRUPLE BUS TRANSCEIVERS WITH 3-STATE OUTPUTS

BULLETIN NO. DL-S 12617, MAY 1978 — REVISED JULY 1980

- P-N-P Inputs for Minimal Input Loading (200  $\mu$ A Maximum)
- High-Speed Schottky Circuitry<sup>†</sup>
- 3-State Outputs for Driver and Receiver
- Party-Line (Data-Bus) Operation
- Single 5-V Supply
- N8T26A Driver has 48-mA Current Sink Capability
- Designed to be Interchangeable with Signetics N8T26 and N8T26A, also Called 8T26 and 8T26A

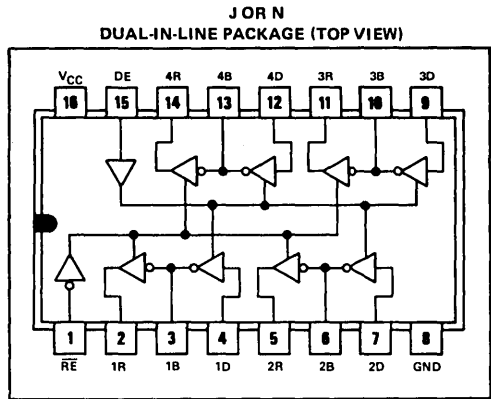

## description

The N8T26 and N8T26A are quadruple transceivers utilizing Schottky-diode-clamped transistors. Both the driver and receiver have three-state outputs. With p-n-p inputs, the input loading is reduced to a maximum input current of 200 microamperes. These devices are capable of high switching rates into high-capacitance loads and are suitable for driving long bus lines.

The N8T26 and N8T26A are characterized for operation from 0°C to 70°C.

## schematics of inputs and outputs

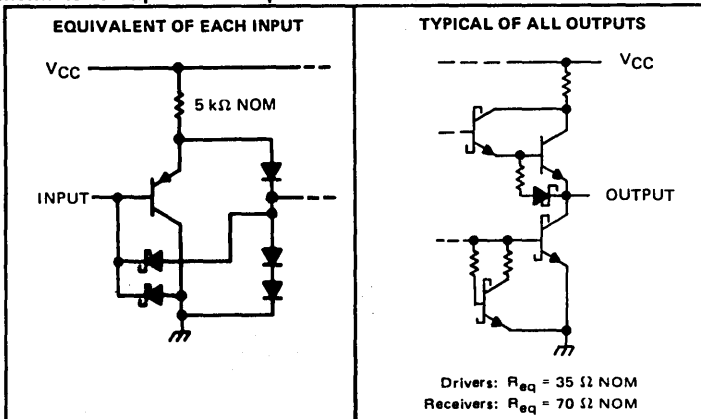

FUNCTION TABLE (DRIVER)

INPUT		OUTPUT
D	DE	B
L	H	H
H	H	L
X	L	Z

FUNCTION TABLE (RECEIVER)

INPUT		OUTPUT
B	RE	R
L	L	H
H	L	L
X	H	Z

H = high level, L = low level,

X = irrelevant, Z = high impedance

## absolute maximum ratings over operating free-air temperature range (unless otherwise noted)

Supply voltage, $V_{CC}$ (see Note 1)	7 V
Input voltage	5.5 V
Continuous total dissipation at (or below) 25°C free-air temperature (see Note 2):	J package 1025 mW
	N package 1150 mW
Operating free-air temperature range	0°C to 70°C
Storage temperature range	-65°C to 150°C
Lead temperature 1/16 inch (1,6 mm) from case for 60 seconds: J package	300°C
Lead temperature 1/16 inch (1,6 mm) from case for 10 seconds: N package	260°C

NOTES: 1. Voltage values are with respect to network ground terminal.

2. For operation above 25°C free-air temperature, derate the J package at the rate of 8.2 mW/°C and the N package at the rate of 9.2 mW/°C.

Copyright © 1980 by Texas Instruments Incorporated

**TEXAS INSTRUMENTS**  
INCORPORATED  
POST OFFICE BOX 225012 • DALLAS, TEXAS 75265

<sup>†</sup>Integrated Schottky-Barrier diode-clamped transistor is patented by Texas Instruments. U.S. Patent Number 3,463,975.

# TYPE N8T26

## QUADRUPLE BUS TRANSCEIVER WITH 3-STATE OUTPUTS

### N8T26 recommended operating conditions

		MIN	NOM	MAX	UNIT
Supply voltage, $V_{CC}$		4.75	5	5.25	V
High-level output current, $I_{OH}$	Driver, B			-10	mA
	Receiver, R			-2	
Low-level output current, $I_{OL}$	Driver, B			40	mA
	Receiver, R			16	
Operating free-air temperature, $T_A$		0		70	$^{\circ}$ C

### N8T26 electrical characteristics over recommended operating free-air temperature and supply voltage ranges (unless otherwise noted)

PARAMETER		TEST CONDITIONS		MIN	TYP <sup>†</sup>	MAX	UNIT
$V_{IH}$	High-level input voltage	B, D, DE, $\overline{RE}$		2			V
$V_{IL}$	Low-level input voltage	B, D, DE, $\overline{RE}$				0.85	V
$V_{IK}$	Input clamp voltage	B, D, DE, $\overline{RE}$	$I_I = -5$ mA			-1	V
$V_{OH}$	High-level output voltage	B	$V_{IH} = 2$ V, $V_{IL} = 0.85$ V, $I_{OH} = -10$ mA	2.6	3.1		V
		R	$V_{IL} = 0.85$ V, $I_{OH} = -2$ mA	2.6	3.1		
$V_{OL}$	Low-level output voltage	B	$V_{IH} = 2$ V, $I_{OL} = 40$ mA			0.5	V
		R	$V_{IH} = 2$ V, $V_{IL} = 0.85$ V, $I_{OL} = 16$ mA			0.5	
$I_{OZ}$	Off-state (high-impedance state) output current	B, R	DE at 0.85 V, $\overline{RE}$ at 2 V, $V_O = 2.6$ V			100	$\mu$ A
		R	$\overline{RE}$ at 2 V, $V_O = 0.5$ V			-100	
$I_{IH}$	High-level input current	D, DE, $\overline{RE}$	$V_I = 5.25$ V			25	$\mu$ A
$I_{IL}$	Low-level input current	B, D, DE, $\overline{RE}$	$V_I = 0.4$ V			-200	$\mu$ A
$I_{OS}$	Short-circuit output current <sup>§</sup>	B	$V_{CC} = 5.25$ V	-50		-150	mA
		R		-30		-75	
$I_{CC}$	Supply current		$V_{CC} = 5.25$ V, No load			87	mA

### N8T26 switching characteristics, $V_{CC} = 5$ V, $T_A = 25^{\circ}$ C

PARAMETER		FROM	TO	TEST CONDITIONS	MIN	TYP	MAX	UNIT
$t_{PLH}$	Propagation delay time, low-to-high-level output	B	R	$C_L = 30$ pF, See Figure 1		8	18	ns
$t_{PHL}$	Propagation delay time, high-to-low-level output					7	10	
$t_{PLH}$	Propagation delay time, low-to-high-level output	D	B	$C_L = 300$ pF, See Figure 2		14	20	ns
$t_{PHL}$	Propagation delay time, high-to-low-level output					12	20	
$t_{PLZ}$	Output disable time from low level		$\overline{RE}$	$C_L = 30$ pF, See Figure 3		9	17	ns
$t_{PZL}$	Output enable time to low level		R				15	
$t_{PLZ}$	Output disable time from low level		DE	$C_L = 300$ pF, See Figure 4		20	43	ns
$t_{PZL}$	Output enable time to low level		B				20	

<sup>†</sup> All typical values are at  $T_A = 25^{\circ}$  C and  $V_{CC} = 5$  V.

<sup>§</sup> Only one output should be shorted at a time, and duration of the short circuit should not exceed one second.

# TYPE N8T26A

## QUADRUPLE BUS TRANSCEIVER WITH 3-STATE OUTPUTS

### N8T26A recommended operating conditions

		MIN	NOM	MAX	UNIT
Supply voltage, $V_{CC}$		4.75	5	5.25	V
High-level output current, $I_{OH}$	Driver, B	-10			mA
	Receiver, R	-2			
Low-level output current, $I_{OL}$	Driver, B	48			mA
	Receiver, R	20			
Operating free-air temperature, $T_A$		0	70		°C

### N8T26A electrical characteristics over recommended operating free-air temperature and supply voltage ranges (unless otherwise noted)

PARAMETER		TEST CONDITIONS		MIN	TYP†	MAX	UNIT
$V_{IH}$	High-level input voltage	B, D, DE, $\overline{RE}$		2			V
$V_{IL}$	Low-level input voltage	B, D, DE, $\overline{RE}$				0.85	V
$V_{IK}$	Input clamp voltage	B, D, DE, $\overline{RE}$	$I_I = -12$ mA			-1	V
$V_{OH}$	High-level output voltage	B	$V_{IH} = 2$ V, $V_{IL} = 0.85$ V, $I_{OH} = -10$ mA	2.6	3.1		V
		R	$V_{IL} = 0.85$ V $I_{OH} = -2$ mA	2.6	3.1		
			$V_{IL} = 0.85$ V $I_{OH} = -100$ $\mu$ A	3.5			
$V_{OL}$	Low-level output voltage	B	$V_{IH} = 2$ V, $I_{OL} = 48$ mA			0.5	V
		R	$V_{IH} = 2$ V, $V_{IL} = 0.85$ V, $I_{OL} = 20$ mA			0.5	
$I_{OZ}$	Off-state (high-impedance state) output current	B, R	DE at 0.85 V $\overline{RE}$ at 2 V, $V_O = 2.6$ V			100	$\mu$ A
		B, R	DE at 0.85 V, $\overline{RE}$ at 2 V, $V_O = 0.5$ V			-100	
$I_{IH}$	High-level input current	D, DE, $\overline{RE}$	$V_I = 5.25$ V			25	$\mu$ A
$I_{IL}$	Low-level input current	B, D, DE, $\overline{RE}$	$V_I = 0.4$ V			-200	$\mu$ A
		D	$V_I = 0.4$ V, DE at 0.85 V			-25	
$I_{OS}$	Short-circuit output current§	B	$V_{CC} = 5.25$ V			-50	mA
		R				-30	
$I_{CC}$	Supply current	$V_{CC} = 5.25$ V, No load				87	mA

### N8T26A switching characteristics, $V_{CC} = 5$ V, $T_A = 25^\circ$ C

PARAMETER		FROM	TO	TEST CONDITIONS		MIN	TYP	MAX	UNIT
$t_{PLH}$	Propagation delay time, low-to-high-level output	B	R	$C_L = 30$ pF, See Figure 1		8	14		ns
$t_{PHL}$	Propagation delay time, high-to-low-level output					7	14		
$t_{PLH}$	Propagation delay time, low-to-high-level output	D	B	$C_L = 300$ pF, See Figure 2		12	14		ns
$t_{PHL}$	Propagation delay time, high-to-low-level output					10	14		
$t_{PLZ}$	Output disable time from low level	$\overline{RE}$	R	$C_L = 30$ pF, See Figure 3		7	15		ns
$t_{ZL}$	Output enable time to low level					12	20		
$t_{PLZ}$	Output disable time from low level	DE	B	$C_L = 300$ pF, See Figure 4		14	20		ns
$t_{ZL}$	Output enable time to low level					17	25		

† All typical values are at  $T_A = 25^\circ$  C and  $V_{CC} = 5$  V.

§ Only one output should be shorted at a time, and duration of the short circuit should not exceed one second.

**TEXAS INSTRUMENTS**  
INCORPORATED

POST OFFICE BOX 225012 • DALLAS, TEXAS 75265

# TYPES N8T26, N8T26A

## QUADRUPLE BUS TRANSCEIVERS WITH 3-STATE OUTPUTS

### PARAMETER MEASUREMENT INFORMATION

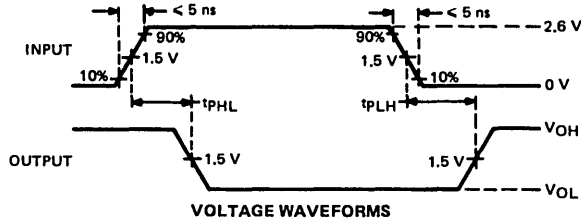
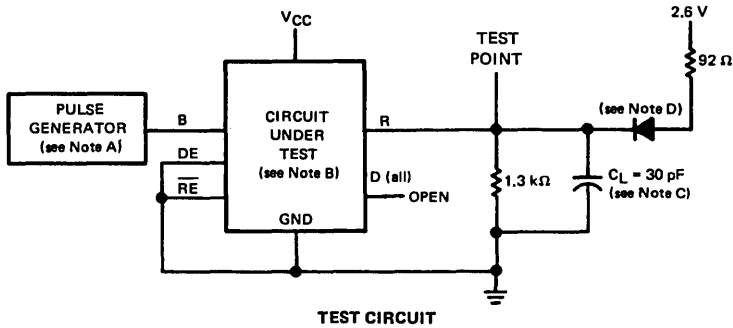

**FIGURE 1—PROPAGATION DELAY TIMES FROM BUS TO RECEIVER OUTPUT**

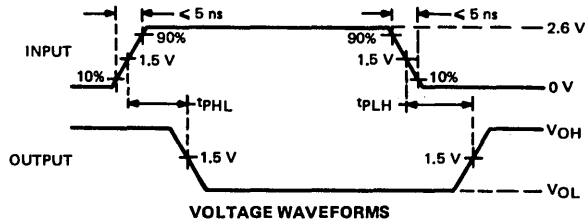
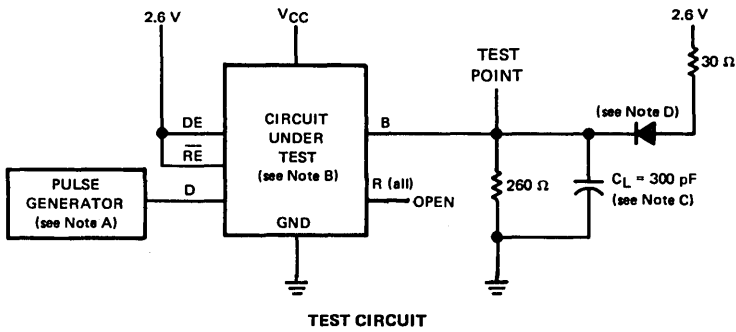

**FIGURE 2—PROPAGATION DELAY TIMES FROM DRIVER INPUT TO BUS**

- NOTES: A. The pulse generator in Figures 1 and 2 has the following characteristics: PRR = 10 MHz, duty cycle = 50%,  $Z_{out} \approx 50 \Omega$ .  
 B. All inputs and outputs not shown are open.  
 C.  $C_L$  includes probe and jig capacitance.  
 D. All diodes are 1N916 or 1N3064.

# TYPES N8T26, N8T26A

## QUADRUPLE BUS TRANSCEIVERS WITH 3-STATE OUTPUTS

### PARAMETER MEASUREMENT INFORMATION

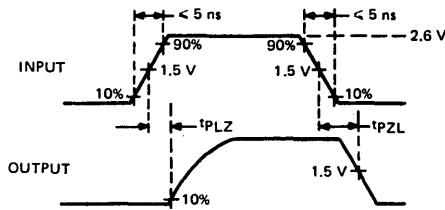
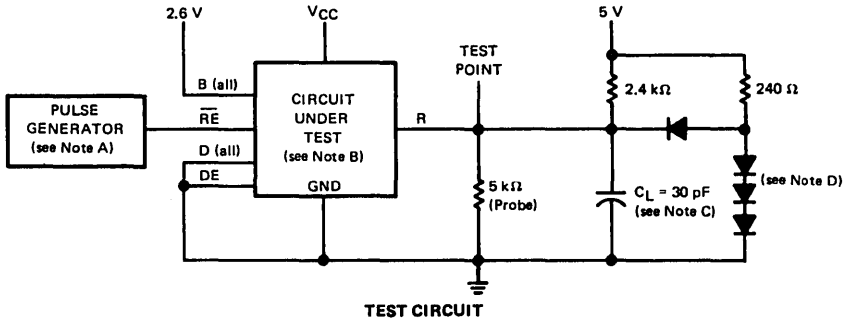

VOLTAGE WAVEFORMS  
FIGURE 3—RECEIVER ENABLE AND DISABLE TIMES

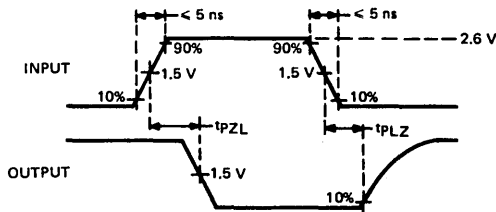
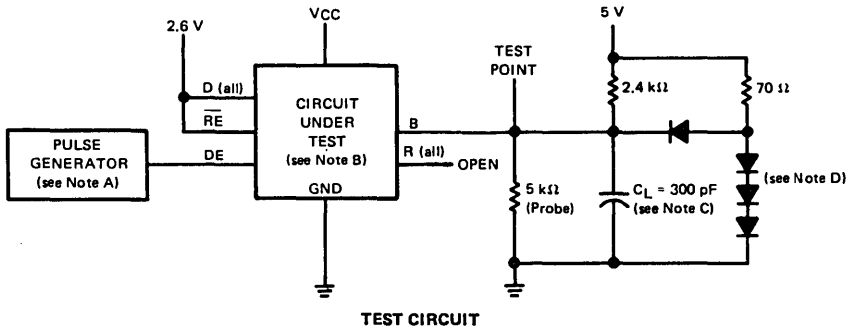

VOLTAGE WAVEFORMS  
FIGURE 4—DRIVER ENABLE AND DISABLE TIMES

- NOTES: A. The pulse generator in Figures 3 and 4 has the following characteristics: PRR = 5 MHz, duty cycle = 50%,  $Z_{out} \approx 50 \Omega$ .  
 B. All inputs and outputs not shown are open.  
 C.  $C_L$  includes probe and jig capacitance.  
 D. All diodes are 1N916 or 1N3064.





# INTERFACE CIRCUITS

# TYPES SN55107A, SN55107B, SN55108A, SN55108B, SN75107A, SN75107B, SN75108A, SN75108B DUAL LINE RECEIVERS

BULLETIN NO. DL-S 12493, JANUARY 1977

SN55107A, SN55107B, SN55108A,  
SN55108B . . . J DUAL-IN-LINE PACKAGE  
SN75107A, SN75107B, SN75108A,  
SN75108B . . . J OR N DUAL-IN-LINE PACKAGE  
(TOP VIEW)

- High Speed
- Standard Supply Voltages
- Dual Channels
- High Common-Mode Rejection Ratio
- High Input Impedance
- High Input Sensitivity
- Differential Input Common-Mode Range of  $\pm 3$  V
- Differential Input Common-Mode Range of More than  $\pm 15$  V Using External Attenuator
- Strobe Inputs For Receiver Selection
- Gate Inputs For Logic Versatility
- TTL or DTL Drive Capability
- High D-C Noise Margin
- '107A and '107B Have Totem-Pole Outputs
- '108A and '108B Have Open-Collector Outputs
- "B" Versions Have Diode-Protected Input Stage For Power-Off Condition

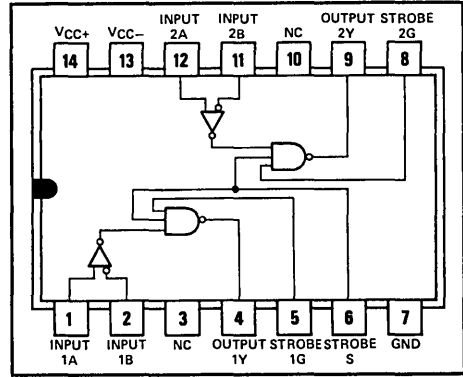

NC—No internal connection

FUNCTION TABLE

DIFFERENTIAL INPUTS A - B	STROBES		OUTPUT Y
	G	S	
$V_{ID} > 25$ mV	X	X	H
	X	L	H
	L	X	H
$-25$ mV $< V_{ID} < 25$ mV	H	H	Indeterminate
	X	L	H
	L	X	H
$V_{ID} < -25$ mV	L	X	H
	H	H	L

H = high level, L = low level, X = irrelevant

## description

These circuits are TTL/DTL compatible high-speed line receivers. Each is a monolithic dual circuit featuring two independent channels. They are designed for general use as well as such specific applications as data comparators and balanced, unbalanced, and party-line transmission systems. These devices are unilaterally interchangeable with and replace SN55107, SN55108, SN75107, and SN75108, but offer diode-clamped strobe inputs to simplify circuit design.

The essential difference between the "A" and "B" versions can be seen in the schematics. Input-protection diodes are in series with the collectors of the differential-input transistors of the "B" versions. These diodes are useful in certain "party-line" systems that may have multiple  $V_{CC+}$  power supplies and may be operated with some of the  $V_{CC+}$  supplies turned off. In such a system, if a supply is turned off and allowed to go to ground, the equivalent input circuit connected to that supply would be as follows:

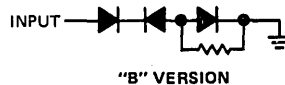
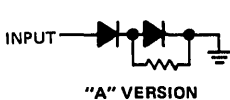

This would be a problem in specific systems that might possibly have the transmission lines biased to some potential greater than 1.4 volts.

The SN55107A, SN55107B, SN55108A, and SN55108B, are characterized for operation over the full military temperature range of  $-55^{\circ}\text{C}$  to  $125^{\circ}\text{C}$ . The SN75107A, SN75107B, SN75108A, and SN75108B are characterized for operation from  $0^{\circ}\text{C}$  to  $70^{\circ}\text{C}$ .

TEXAS INSTRUMENTS  
INCORPORATED

POST OFFICE BOX 225012 • DALLAS, TEXAS 75265

# TYPES SN55107A, SN55107B, SN55108A, SN55108B, SN75107A, SN75107B, SN75108A, SN75108B DUAL LINE RECEIVERS

## design characteristics

The '107A, '107B, '108A, and '108B line receivers are TTL-compatible dual circuits intended for use in high-speed data-transmission systems. They are designed to detect low-level differential signals in the presence of common-mode noise and variations of temperature and supplies. Dc specifications reflect worst-case conditions of temperature, supply voltages, and input voltages.

These receivers feature independent channels with common voltage supply and ground terminals. The '107A and '107B feature TTL-compatible active pull-up (totem-pole) outputs. The '108A and '108B are also TTL-compatible, but feature an open-collector output configuration that permits the wired-AND logic connection with similar outputs (such as the SN5401/SN7401 TTL gate or other '108A/'108B line receivers). This permits a level of logic to be implemented without extra delay. All other features of the line receivers are identical.

The input common-mode voltage range is  $\pm 3$  volts. This is adequate for application in most systems. In systems with requirements for greater common-mode voltage range, input attenuators may be used to decrease the noise to an acceptable level at the receiver-input terminals.

The receivers feature individual strobe inputs for each channel and a strobe input common to both channels for logic versatility. The strobe inputs are tested to guarantee 400 millivolts of dc noise margin when interfaced with Series 54/74 TTL.

The circuits feature high input impedance and low input currents, which induce very little loading on the transmission line. This makes these devices especially useful in party-line systems. The excellent input sensitivity is particularly important when data is to be detected at the end of a long transmission line and the amplitude of the data has deteriorated due to cable losses. These line receivers are designed to detect input signals of 25 millivolts (or greater) amplitude and convert the polarity of the signal into appropriate TTL-compatible output logic levels. For applications that require a greater sensitivity ( $\pm 10$  mV), the SN75207, SN75207B, SN75208, and SN75208B are recommended.

## schematic (each receiver)

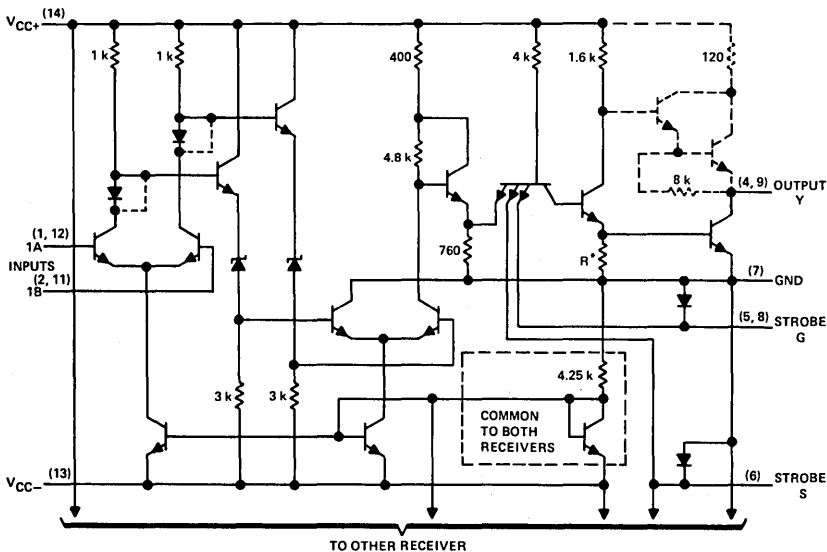

\*  $R = 1$  k $\Omega$  for '107A and '107B, 750  $\Omega$  for '108A and '108B.

NOTES: A. Resistor values shown are nominal and in ohms.

B. Components shown with dashed lines in the output circuitry are applicable to the '107A and 107B only. Diodes in series with the collectors of the differential input transistors are short-circuited on '107A and '108A.

# TYPES SN55107A, SN55107B, SN55108A, SN55108B, SN75107A, SN75107B, SN75108A, SN75108B DUAL LINE RECEIVERS

absolute maximum ratings over operating free-air temperature range (unless otherwise noted)

Supply voltage $V_{CC+}$ (see Note 1)	7 V
Supply voltage $V_{CC-}$	-7 V
Differential input voltage (see Note 2)	$\pm 6$ V
Common-mode input voltage (see Note 3)	$\pm 5$ V
Strobe input voltage	5.5 V
Continuous total dissipation at (or below) 70°C free-air temperature (see Note 4)	600 mW
Operating free-air temperature range, Series 55	-55°C to 125°C
Series 75	0°C to 70°C
Storage temperature range	-65°C to 150°C

recommended operating conditions (see note 5)

	SN55107A, SN55107B SN55108A, SN55108B			SN75107A, SN75107B SN75108A, SN75108B			UNIT
	MIN	NOM	MAX	MIN	NOM	MAX	
Supply voltage $V_{CC+}$	4.5	5	5.5	4.75	5	5.25	V
Supply voltage $V_{CC-}$	-4.5	-5	-5.5	-4.75	-5	-5.25	V
Low-level output current, $I_{OL}$			-16			-16	mA
Differential input voltage, $V_{ID}$ (see Note 6)	-5†	5	-5†	5	5	5	V
Common-mode input voltage, $V_{IC}$ (see Notes 6 and 7)	-3†	3	-3†	3	3	3	V
Input voltage range, any differential input to ground (see Note 6)	-5†	3	-5†	3	3	3	V
Operating free-air temperature, $T_A$	-55	125	0	70	70	70	°C

5

† The algebraic convention, where the less positive (more negative) limit is designated as minimum, is used in this data sheet for logic voltage levels only.

- NOTES:
- All voltage values, except differential voltages, are with respect to network ground terminal.
  - Differential voltage values are at the noninverting (A) terminal with respect to the inverting (B) terminal.
  - Common-mode input voltage is the average of the voltages at the A and B inputs.
  - For operation of SN55107A, SN55107B, SN55108A, or SN55108B above 70°C free-air temperature, refer to Dissipation Derating Curves in the Thermal Information section, which starts on page 2-1. In the J package, these Series 55 chips are alloy-mounted; Series 75 chips are glass-mounted.
  - When using only one channel of the line receiver, the strobe G of the unused channel should be grounded and at least one of the differential inputs of the unused receiver should be terminated at some voltage between -3 V and 3 V.
  - The recommended combinations of input voltages fall within the shaded area of the figure at the right.
  - The common-mode voltage may be as low as -4 V provided that the more positive of the two inputs is not more negative than -3 V.

RECOMMENDED COMBINATIONS  
OF INPUT VOLTAGES

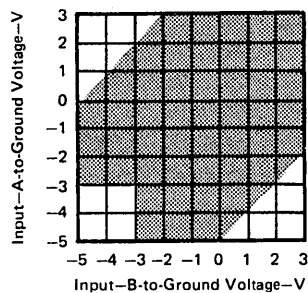

**TEXAS INSTRUMENTS**  
INCORPORATED

POST OFFICE BOX 225012 • DALLAS, TEXAS 75265

# TYPES SN55107A, SN55107B, SN55108A, SN55108B, SN75107A, SN75107B, SN75108A, SN75108B DUAL LINE RECEIVERS

definition of input logic levels<sup>†</sup>

		MIN	MAX	UNIT
V <sub>IDH</sub>	High-level input voltage between differential inputs	0.025	5	V
V <sub>IDL</sub>	Low-level input voltage between differential inputs	-5	-0.025	V
V <sub>IH(S)</sub>	High-level input voltage at strobe inputs	2	5.5	V
V <sub>IL(S)</sub>	Low-level input voltage at strobe inputs	0	0.8	V

<sup>†</sup>The algebraic convention where the more positive (less negative) limit is designated as maximum is used in this data sheet for logic voltage levels only.

electrical characteristics over recommended operating free-air temperature range (unless otherwise noted)

PARAMETER	TEST CONDITIONS <sup>‡</sup>		'107A, '107B		'108A, '108B		UNIT	
			MIN	TYP <sup>§</sup> MAX	MIN	TYP <sup>§</sup> MAX		
I <sub>IH</sub> High-level input current	A	V <sub>CC±</sub> = MAX	V <sub>ID</sub> = 5 V	30	75	30	75	μA
			V <sub>ID</sub> = -5 V	30	75	30	75	
I <sub>IL</sub> Low-level input current	A	V <sub>CC±</sub> = MAX	V <sub>ID</sub> = -5 V		-10		-10	μA
			V <sub>ID</sub> = 5 V		-10		-10	
I <sub>IH</sub> High-level input current into 1G or 2G		V <sub>CC±</sub> = MAX, V <sub>IH(S)</sub> = 2.4 V		40		40	μA	
		V <sub>CC±</sub> = MAX, V <sub>IH(S)</sub> = MAX V <sub>CC+</sub>		1		1	mA	
I <sub>IL</sub> Low-level input current into 1G or 2G		V <sub>CC±</sub> = MAX, V <sub>IL(S)</sub> = 0.4 V		-1.6		-1.6	mA	
I <sub>IH</sub> High-level input current into S		V <sub>CC±</sub> = MAX, V <sub>IH(S)</sub> = 2.4 V		80		80	μA	
		V <sub>CC±</sub> = MAX, V <sub>IH(S)</sub> = MAX V <sub>CC+</sub>		2		2	mA	
I <sub>IL</sub> Low-level input current into S		V <sub>CC±</sub> = MAX, V <sub>IL(S)</sub> = 0.4 V		-3.2		-3.2	mA	
V <sub>OH</sub> High-level output voltage		V <sub>CC±</sub> = MIN, V <sub>IL(S)</sub> = 0.8 V, V <sub>IDH</sub> = 25 mV I <sub>OH</sub> = -400 μA, V <sub>IC</sub> = -3 V to 3 V	2.4				V	
V <sub>OL</sub> Low-level output voltage		V <sub>CC±</sub> = MIN, V <sub>IH(S)</sub> = 2 V, V <sub>IDL</sub> = -25 mV I <sub>OL</sub> = 16 mA, V <sub>IC</sub> = -3 V to 3 V		0.4		0.4	V	
I <sub>OH</sub> High-level output current		V <sub>CC±</sub> = MIN, V <sub>OH</sub> = MAX V <sub>CC+</sub>				250	μA	
I <sub>OS</sub> Short-circuit output current <sup>¶</sup>		V <sub>CC±</sub> = MAX	-18	-70			mA	
I <sub>CCH+</sub> Supply current from V <sub>CC+</sub> , outputs high		V <sub>CC±</sub> = MAX, T <sub>A</sub> = 25°C	18	30	18	30	mA	
I <sub>CCH-</sub> Supply current from V <sub>CC-</sub> , outputs high		V <sub>CC±</sub> = MAX, T <sub>A</sub> = 25°C	-8.4	-15	-8.4	-15	mA	

<sup>‡</sup>For conditions shown as MIN or MAX, use the appropriate value specified under recommended operating conditions.

<sup>§</sup>All typical values are at V<sub>CC+</sub> = 5 V, V<sub>CC-</sub> = -5 V, T<sub>A</sub> = 25°C.

<sup>¶</sup>Not more than one output should be shorted at a time.

switching characteristics, V<sub>CC±</sub> = ±5 V, T<sub>A</sub> = 25°C, see figure 1

PARAMETER	TEST CONDITIONS	'107A, '107B		'108A, '108B		UNIT
		MIN	TYP MAX	MIN	TYP MAX	
t <sub>PLH(D)</sub> Propagation delay time, low-to-high-level output, from differential inputs A and B	R <sub>L</sub> = 390 Ω, C <sub>L</sub> = 50 pF		17	25		ns
	R <sub>L</sub> = 390 Ω, C <sub>L</sub> = 15 pF				19	
t <sub>PHL(D)</sub> Propagation delay time, high-to-low-level output, from differential inputs A and B	R <sub>L</sub> = 390 Ω, C <sub>L</sub> = 50 pF		17	25		ns
	R <sub>L</sub> = 390 Ω, C <sub>L</sub> = 15 pF				19	
t <sub>PLH(S)</sub> Propagation delay time, low-to-high-level output, from strobe input G or S	R <sub>L</sub> = 390 Ω, C <sub>L</sub> = 50 pF		10	15		ns
	R <sub>L</sub> = 390 Ω, C <sub>L</sub> = 15 pF				13	
t <sub>PHL(S)</sub> Propagation delay time, high-to-low-level output, from strobe input G or S	R <sub>L</sub> = 390 Ω, C <sub>L</sub> = 50 pF		8	15		ns
	R <sub>L</sub> = 390 Ω, C <sub>L</sub> = 15 pF				13	

# TYPES SN55107A, SN55107B, SN55108A, SN55108B, SN75107A, SN75107B, SN75108A, SN75108B DUAL LINE RECEIVERS

## PARAMETER MEASUREMENT INFORMATION

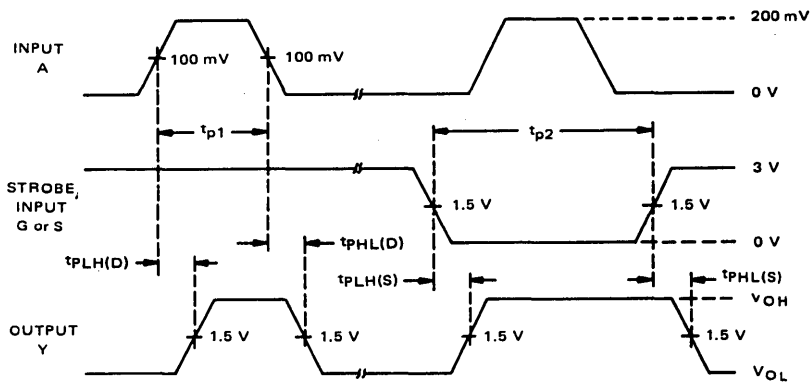
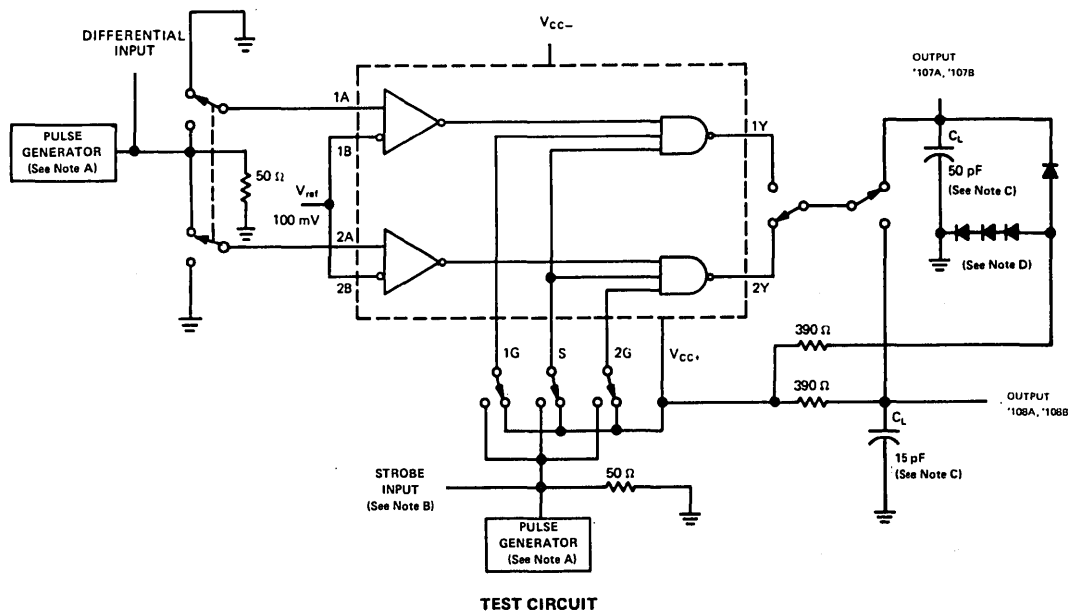

- NOTES: A. The pulse generators have the following characteristics:  $Z_{out} = 50 \Omega$ ,  $t_r = t_f = 10 \pm 5 \text{ ns}$ ,  $t_{p1} = 500 \text{ ns}$ ,  $\text{PRR} = 1 \text{ MHz}$ ,  $t_{p2} = 1 \mu\text{s}$ ,  $\text{PRR} = 500 \text{ kHz}$ .
- B. Strobe input pulse is applied to Strobe 1G when inputs 1A-1B are being tested, to Strobe S when inputs 1A-1B or 2A-2B are being tested, and to Strobe 2G when inputs 2A-2B are being tested.
- C.  $C_L$  includes probe and jig capacitance.
- D. All diodes are 1N916.

FIGURE 1—PROPAGATION DELAY TIMES

# TYPES SN55107A, SN55107B, SN55108A, SN55108B, SN75107A, SN75107B, SN75108A, SN75108B DUAL LINE RECEIVERS

## TYPICAL CHARACTERISTICS†

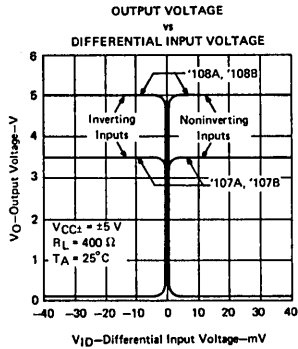

FIGURE 2

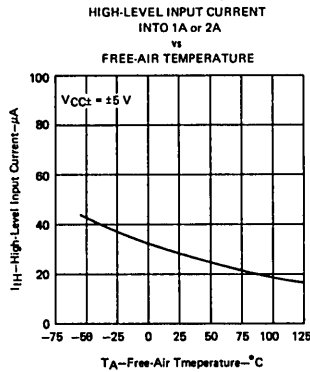

FIGURE 3

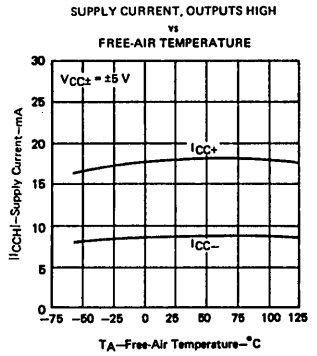

FIGURE 4

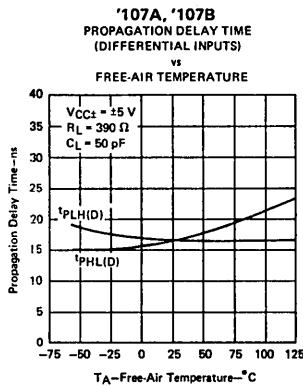

FIGURE 5

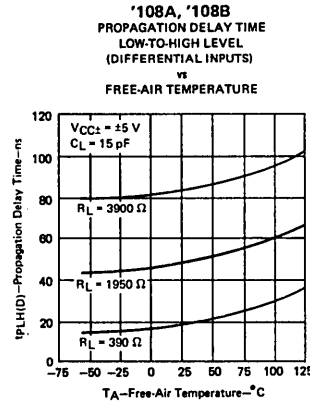

FIGURE 6

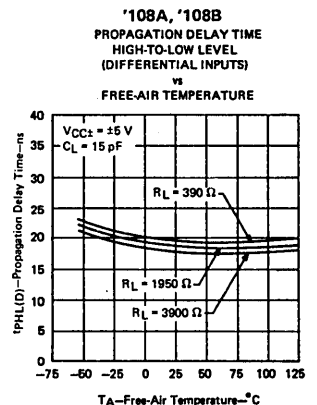

FIGURE 7

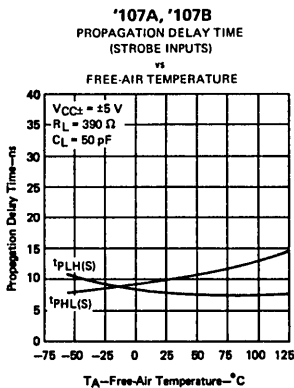

FIGURE 8

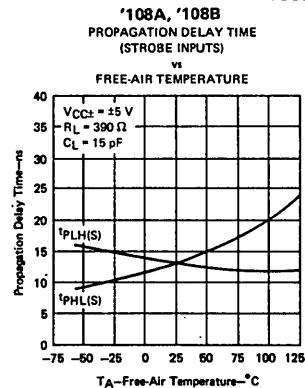

FIGURE 9

† Data for temperatures below 0°C and above 70°C are applicable for Series 55 devices only.

# TYPES SN55107A, SN55107B, SN55108A, SN55108B, SN75107A, SN75107B, SN75108A, SN75108B DUAL LINE RECEIVERS

## TYPICAL APPLICATION DATA

### basic balanced-line transmission system

The '107A, '107B, '108A, and '108B dual line circuits are designed specifically for use in high-speed data transmission systems that utilize balanced, terminated transmission lines such as twisted-pair lines. The system operates in the balanced mode, so noise induced on one line is also induced on the other. The noise appears common-mode at the receiver input terminals where it is rejected. The ground connection between the line driver and receiver is not part of the signal circuit so that system performance is not affected by circulating ground currents.

The unique driver-output circuit allows terminated transmission lines to be driven at normal line impedances. High-speed system operation is ensured since line reflections are virtually eliminated when terminated lines are used. Crosstalk is minimized by low signal amplitudes and low line impedances.

The typical data delay in a system is approximately  $(30 + 1.3 L)$  nanoseconds, where  $L$  is the distance in feet separating the driver and receiver. This delay includes one gate delay in both the driver and receiver.

Data is impressed on the balanced-line system by unbalancing the line voltages with the driver output current. The driven line is selected by appropriate driver-input logic levels. The voltage difference is approximately:

$$V_{DIFF} \approx 1/2 I_{O(on)} \cdot R_T$$

High series line resistance will cause degradation of the signal. The receivers, however, will detect signals as low as 25 mV (or less). For normal line resistances, data may be recovered from lines of several thousand feet in length.

Line-termination resistors ( $R_T$ ) are required only at the extreme ends of the line. For short lines, termination resistors at the receiver only may prove adequate. The signal amplitude will then be approximately:

$$V_{DIFF} \approx I_{O(on)} \cdot R_T$$

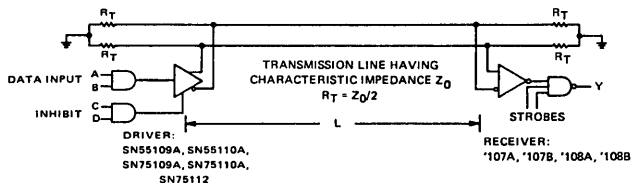

FIGURE 10

### data-bus or party-line system

The strobe feature of the receivers and the inhibit feature of the drivers allow these dual line circuits to be used in data-bus or party-line systems. In these applications, several drivers and receivers may share a common transmission line. An enabled driver transmits data to all enabled receivers on the line while other drivers and receivers are disabled. Data is thus time-multiplexed on the transmission line. The device specifications allow widely varying thermal and electrical environments at the various driver and receiver locations. The data-bus system offers maximum performance at minimum cost.

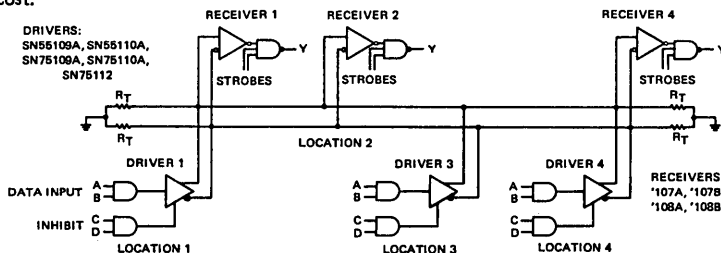

FIGURE 11

# TYPES SN55107A, SN55107B, SN55108A, SN55108B, SN75107A, SN75107B, SN75108A, SN75108B DUAL LINE RECEIVERS

## TYPICAL APPLICATION DATA

### unbalanced or single-line systems

These dual line circuits may also be used in unbalanced or single-line systems. Although these systems do not offer the same performance as balanced systems for long lines, they are adequate for very short lines where environmental noise is not severe.

The receiver threshold level is established by applying a d-c reference voltage to one receiver input terminal. The signal from the transmission line is applied to the remaining input. The reference voltage should be optimized so that signal swing is symmetrical about it for maximum noise margin. The reference voltage should be in the range of  $-3$  volts to  $+3$  volts. It can be provided by a voltage supply or by a voltage divider from an available supply voltage.

A single-ended output from a driver may be used in single-line systems. Coaxial or shielded line is preferred for minimum noise and crosstalk problems. For large signal swings, the high output current (typically 27 mA) of the SN75112 is recommended. Drivers may be paralleled for higher current. When using only one channel of the line drivers, the other channel should be inhibited and/or have its outputs grounded.

5

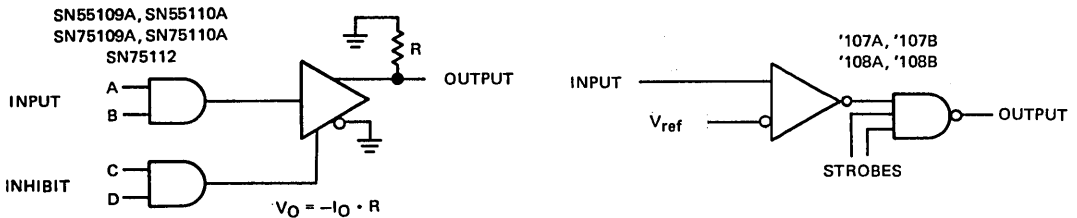

FIGURE 12

### '108A, '108B dot-AND output connections

The '108A, '108B line receivers feature an open-collector-output circuit that can be connected in the dot-AND logic configuration with other similar open-collector outputs. This allows a level of logic to be implemented without additional logic delay.

For rules for such dot-AND connections, refer to the SN5401/SN7401 data sheet.

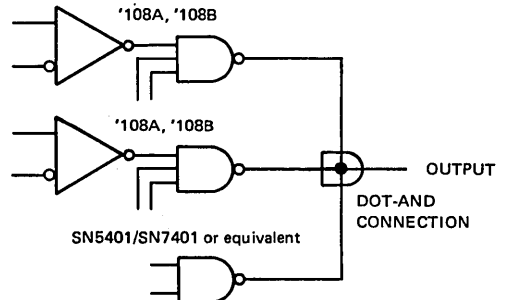

FIGURE 13

### increasing common-mode input voltage range of receiver

The common-mode voltage range or CMVR is defined as the range of voltage applied simultaneously to both input terminals that if exceeded does not allow normal operation of the receiver.

The recommended operating CMVR is  $\pm 3$  volts, making it useful in all but the noisiest environments. In extremely noisy environments, common-mode voltage can easily reach  $\pm 10$  V to  $\pm 15$  V if some precautions are not taken to reduce ground and power supply noise, as well as crosstalk problems. When the receiver must operate in such conditions, input attenuators should be used to decrease the system common-mode noise to a tolerable level at the receiver inputs. Differential noise is also reduced by the same ratio.

These attenuators have been intentionally omitted from the receiver input terminals so the designer may select resistors that will be compatible with his particular application or environment. Furthermore, the use of attenuators adversely affects the input sensitivity, the propagation delay time, the power dissipation, and in some cases (depending on the selected resistor values) the input impedance, therefore reducing the versatility of the receiver.



# TYPES SN55107A, SN55107B, SN55108A, SN55108B, SN75107A, SN75107B, SN75108A, SN75108B DUAL LINE RECEIVERS

## TYPICAL APPLICATION DATA

### increasing common-mode input voltage range of receiver, continued

The ability of the receiver to operate with approximately  $\pm 15$  volts common-mode voltage at the inputs has been checked using the circuit shown in Figure 14. The resistors R1 and R2 provide a voltage divider network. Dividers with three different values presenting a 5-to-1 attenuation were used so as to operate the differential inputs at approximately  $\pm 3$  volts common-mode voltage. Careful matching of the two attenuators is needed so as to balance the overdrive at the input stage. The resistors used are shown in Table A.

TABLE A

Attenuator 1: R1 = 2 k $\Omega$ , R2 = 0.5 k $\Omega$
Attenuator 2: R1 = 6 k $\Omega$ , R2 = 1.5 k $\Omega$
Attenuator 3: R1 = 12 k $\Omega$ , R2 = 3 k $\Omega$

Table B shows some of the typical switching results obtained under such conditions.

TABLE B – TYPICAL PROPAGATION DELAYS FOR  
RECEIVER WITH ATTENUATOR TEST CIRCUIT  
SHOWN IN FIGURE 14

DEVICE	PARAMETERS	INPUT ATTENUATOR	TYPICAL (ns)
'107A, '107B	t <sub>PLH</sub>	1	20
		2	32
		3	42
	t <sub>PHL</sub>	1	22
		2	31
		3	33
'108A, '108B	t <sub>PLH</sub>	1	36
		2	47
		3	57
	t <sub>PHL</sub>	1	29
		2	38
		3	41

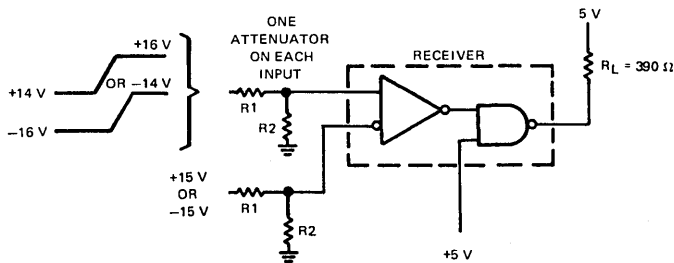

FIGURE 14—COMMON-MODE CIRCUIT FOR TESTING INPUT  
ATTENUATORS, WITH RESULTS SHOWN IN TABLE B

Two methods of terminating a transmission line to reduce reflections are:

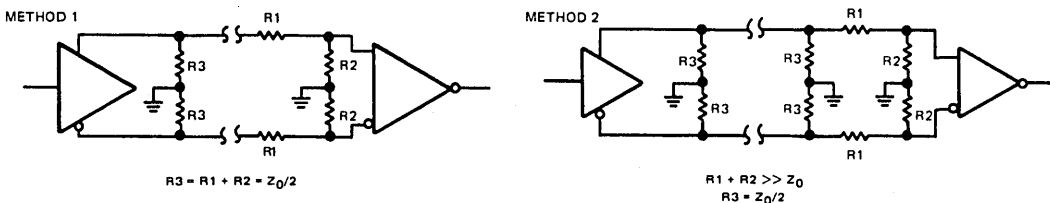

FIGURE 15

The first method uses the resistors as the attenuation network and line termination. The second method uses two additional resistors for the line terminations.

**TYPES SN55107A, SN55107B, SN55108A, SN55108B,  
SN75107A, SN75107B, SN75108A, SN75108B  
DUAL LINE RECEIVERS**

**TYPICAL APPLICATION DATA**

**increasing common-mode input voltage range of receiver, continued**

For party-line operation, method 2 should be used as follows:

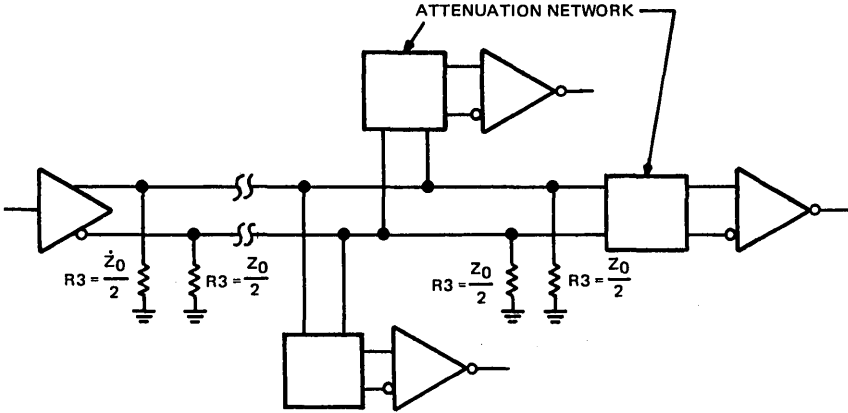

FIGURE 16

To minimize the loading, the values of R1 and R2 should be fairly large. Examples of possible values are shown in Table A.

**furnace control using the SN75108A**

The furnace control circuit in Figure 17 is an example of the possible use of the SN55107A Series in areas other than what would normally be considered electronic systems. Basically the operation of this control is as follows. When the room temperature is below the desired level, the resistance of the room temperature sensor is high and channel 1 noninverting input is below (less positive than) the reference level set on the input differential amplifier. This situation causes a low output, operating the "heat on" relay and turning on the heat. The channel 2 noninverting input is below the reference level when the bonnet temperature of the furnace reaches the desired level. This causes a low output, thus operating the blower relay. Normally the furnace is shut down when the room temperature reaches the desired level and the channel 1 output goes high, turning the heat off. The blower remains on as long as the bonnet temperature is high, even after the "heat on" relay is off. There is also a safety switch in the bonnet that shuts the furnace down if the temperature there exceeds desired limitations. The types of temperature-sensing devices and bias-resistor values used are determined by the particular operating conditions encountered.

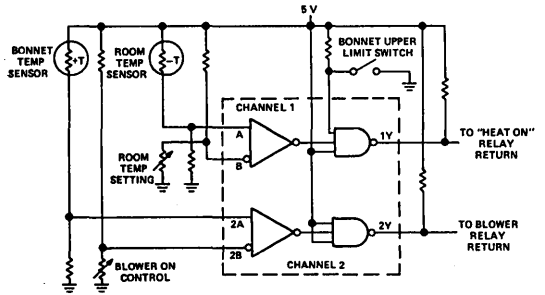

FIGURE 17—FURNACE CONTROL USING SN75108A

# TYPES SN55107A, SN55107B, SN55108A, SN55108B, SN75107A, SN75107B, SN75108A, SN75108B DUAL LINE RECEIVERS

## TYPICAL APPLICATION DATA

### repeaters for long lines

In some cases, the driven line may be so long that the noise level on the line reaches the common-mode limits or the attenuation becomes too large and results in poor reception. In such a case, a simple application of a receiver and a driver as repeaters (shown in Figure 18a) restores the signal level and allows an adequate signal level at the receiving end. If multichannel operation is desired, then proper gating for each channel must be sent through the repeater station using another repeater set as in Figure 18b.

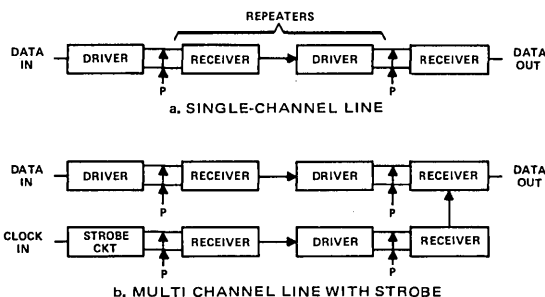

FIGURE 18—RECEIVER-DRIVER REPEATERS

### receiver as dual differential comparator

There are many applications for differential comparators, such as voltage comparison, threshold detection, controlled Schmitt triggering, and pulse width control.

As a differential comparator, a '107A or '108A may be connected so as to compare the noninverting input terminal with the inverting input as shown in Figure 19. Thus the output will be high or low resulting from the A input being greater or less than the reference. The strobe inputs allow additional control over the circuit so that either output or both may be inhibited.

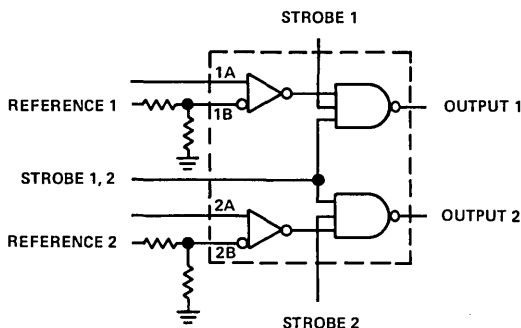
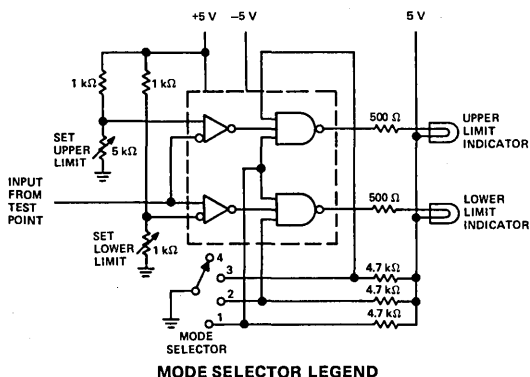

FIGURE 19—SN55107A SERIES RECEIVER AS A DUAL DIFFERENTIAL COMPARATOR

### window detector

The window detector circuit in Figure 20 has a large number of applications in test equipment and in determining upper limits, lower limits, or both at the same time — such as detecting whether a voltage or signal has exceeded its limits or "window". Illumination of the upper-limit (lower-limit) indicator shows that the input voltage is above (below) the selected upper (lower) limit. A mode selector is provided for selecting the desired test. For window detecting, the "upper and lower limits" test position is used.



MODE SELECTOR LEGEND

POSITION	CONDITION
1	OFF
2	TEST FOR UPPER LIMIT
3	TEST FOR LOWER LIMIT
4	TEST FOR UPPER AND LOWER LIMITS

FIGURE 20—WINDOW DETECTOR USING SN75108A

# TYPES SN55107A, SN55107B, SN55108A, SN55108B, SN75107A, SN75107B, SN75108A, SN75108B DUAL LINE RECEIVERS

## TYPICAL APPLICATION DATA

### temperature controller with zero-voltage switching

The circuit in Figure 21 switches an electric resistive heater on or off by providing negative-going pulses to the gate of a triac during the time interval when the line voltage is passing through zero. The pulse generator is the 2N5447 and four diodes. This portion of the circuit provides negative-going pulses during the short time (approximately 100  $\mu$ s) when the line voltage is near zero. These pulses are fed to the inverting input of one channel of the '108A. If the room temperature is below the desired level, the resistance of the thermistor is high and the noninverting input of channel 2 is above the reference level determined by the thermostat setting. This provides a high-level output from channel 2. This output is AND'ed with the positive-going pulses from the output of channel 1, which are reinverted in the 2N5449. This output is AND'ed with the positive-going pulses from the output of channel 1, which are reinverted in the 2N5449.

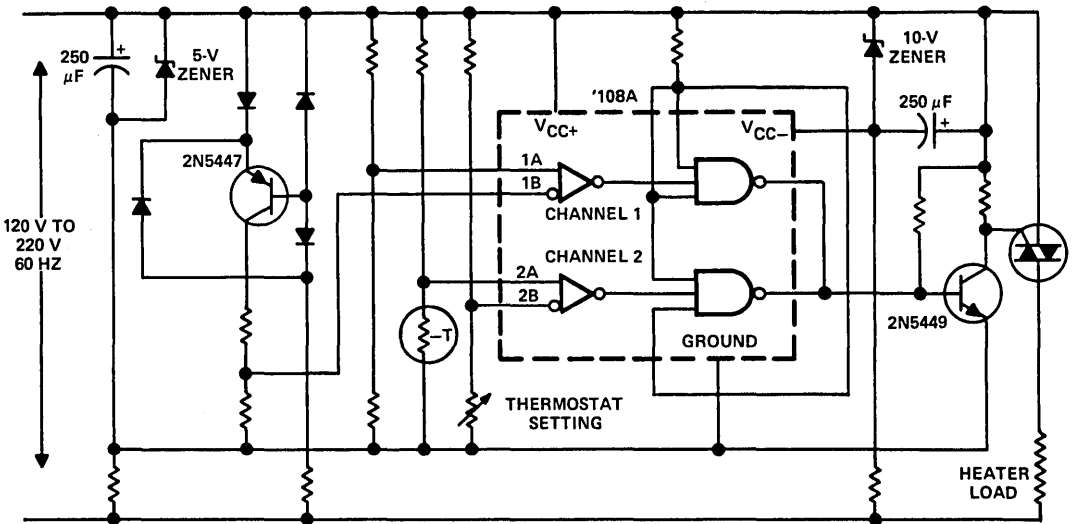

FIGURE 21—ZERO-VOLTAGE SWITCHING TEMPERATURE CONTROLLER

# INTERFACE CIRCUITS

# TYPES SN55109A, SN55110A, SN75109A, SN75110A, SN75112 DUAL LINE DRIVERS

BULLETIN NO. DL-S 12334, DECEMBER 1975—REVISED JANUARY 1977

SN55109A, SN55110A . . . J DUAL-IN-LINE PACKAGE  
SN75109A, SN75110A, SN75112 . . . J OR N DUAL-IN-LINE PACKAGE  
(TOP VIEW)

- Improved Stability over Supply Voltage and Temperature Ranges
- Constant-Current Output
- High Speed
- Standard Supply Voltages
- High Output Impedance
- High Common-Mode Output Voltage Range (–3 V to 10 V)
- TTL Input Compatibility
- Inhibitor Available for Driver Selection

–55°C to 125°C J Package	0°C to 70°C J or N Package	OUTPUT FUNCTION
SN55109A	SN75109A	6-mA Current Switch
SN55110A	SN75110A	12-mA Current Switch
	SN75112	27-mA Current Switch

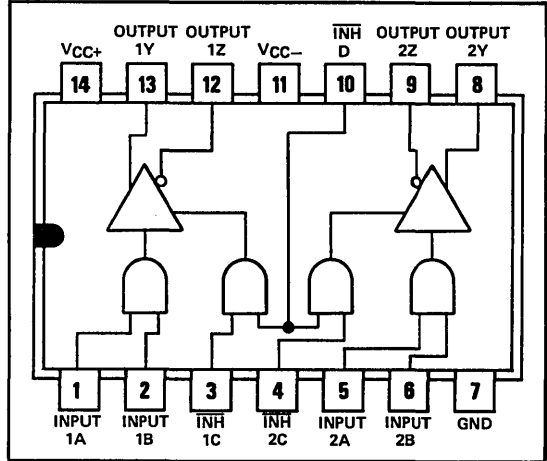

## description

The SN55109A, SN55110A, SN75109A, SN75110A, and SN75112 have improved output current regulation with supply voltage and temperature variations. In addition the higher current of the SN75112 (27 mA) allows data to be transmitted over longer lines. These drivers offer optimum performance when used with the SN55107A, SN55108A, SN75107A, and SN75108A line receivers.

These drivers feature independent channels with common voltage supply and ground terminals. The significant difference between the three drivers is in the output current specification. The driver circuits feature a constant output current that is switched to either of two output terminals by the appropriate logic levels at the input terminals. The output current can be switched off (inhibited) by low logic levels on the inhibit inputs. The output current is nominally 6 milliamperes for the '109A, 12 milliamperes for the '110A, and 27 milliamperes for the SN75112.

The inhibit feature is provided so the circuits can be used in party-line or data-bus applications. A strobe or inhibitor, common to both drivers, is included for increased driver-logic versatility. The output current in the inhibited mode,  $I_{O(off)}$ , is specified so that minimum line loading is induced when the driver is used in a party-line system with other drivers. The output impedance of the driver in the inhibited mode is very high—the output impedance of a transistor biased to cutoff.

The driver outputs have a common-mode voltage range of –3 volts to 10 volts, allowing common-mode voltage on the line without affecting driver performance.

All inputs are diode clamped and are designed to satisfy TTL-system requirements. The inputs are tested at 2.0 volts for high-logic-level input conditions and 0.8 volt for low-logic-level input conditions. These tests guarantee 400 millivolts of noise margin when interfaced with Series 54/74 TTL.

FUNCTION TABLE

LOGIC INPUTS		INHIBITOR INPUTS		OUTPUTS	
A	B	C	D	Y	Z
X	X	L	X	OFF	OFF
X	X	X	L	OFF	OFF
L	X	H	H	ON	OFF
X	L	H	H	ON	OFF
H	H	H	H	OFF	ON

H = high level, L = low level, X = irrelevant

TEXAS INSTRUMENTS  
INCORPORATED

POST OFFICE BOX 225012 • DALLAS, TEXAS 75265

# TYPES SN55109A, SN55110A, SN75109A, SN75110A, SN75112 DUAL LINE DRIVERS

schematic (each driver)

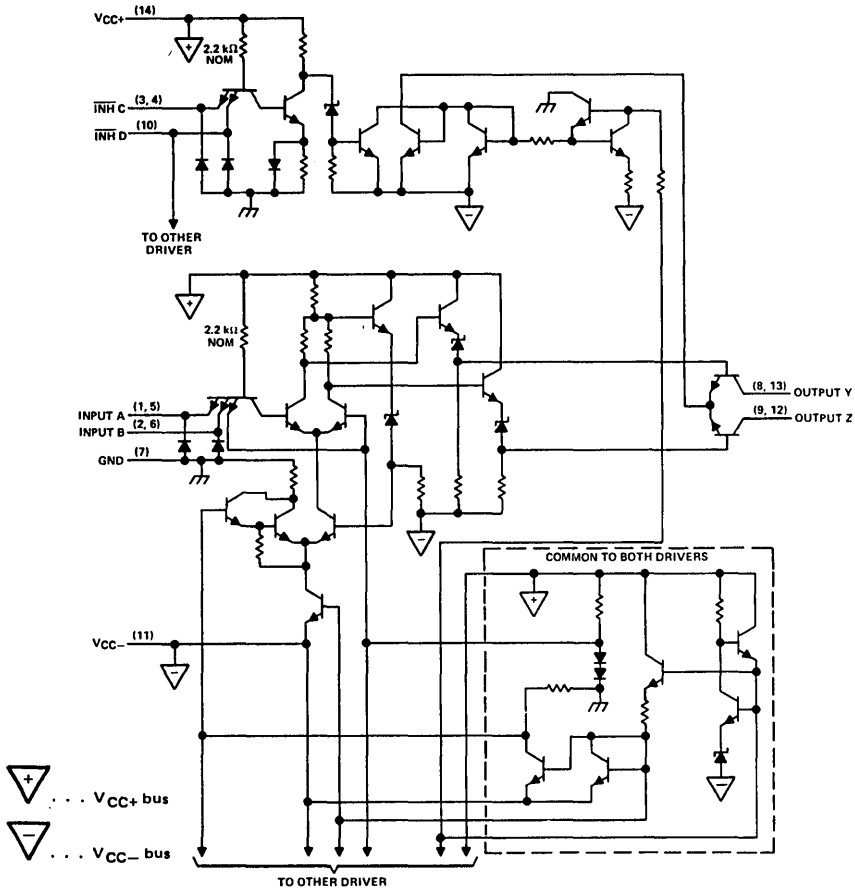

5

**absolute maximum ratings over operating free-air temperature range (unless otherwise noted)**

Supply voltage, $V_{CC+}$ (see Note 1)	7 V	
Supply voltage, $V_{CC-}$	-7 V	
Input voltage (any input)	5.5 V	
Output voltage (any output)	-5 V to 12 V	
Continuous total dissipation at (or below) 25°C free-air temperature (see Note 2): J package	1025 mW	
	N package	1150 mW
Operating free-air temperature, Series 55	-55°C to 125°C	
	Series 75	0°C to 70°C
Storage temperature range	-65°C to 150°C	
Lead temperature 1/16 inch from case for 60 seconds: J package	300°C	
Lead temperature 1/16 inch from case for 10 seconds: N package	260°C	

- NOTES: 1. Voltage values are with respect to network ground terminal.  
 2. For operation above 25°C free-air temperature, refer to Dissipation Derating Curves in the Thermal Information section, which starts on page 2-1. In the J package, SN55109A and SN55110A chips are alloy-mounted; SN75109A, SN75110A, and SN75112 chips are glass-mounted.

recommended operating conditions (see note 3)

	SN55109A, SN55110A			SN75109A, SN75110A, SN75112			UNIT
	MIN	NOM	MAX	MIN	NOM	MAX	
Supply voltage $V_{CC+}$	4.5	5	5.5	4.75	5	5.25	V
Supply voltage $V_{CC-}$	-4.5	-5	-5.5	-4.75	-5	-5.25	V
Positive common-mode output voltage	0		10	0		10	V
Negative common-mode output voltage	0		-3	0		-3	V
Operating free-air temperature, $T_A$	-55		125	0		70	°C

NOTE 3: When using only one channel of the line drivers, the other channel should be inhibited and/or its outputs grounded.

electrical characteristics over recommended operating free-air temperature range (unless otherwise noted)

PARAMETER		TEST CONDITIONS†	SN55109A, SN75109A			SN55110A, SN75110A			SN75112			UNIT
			MIN	TYP‡	MAX	MIN	TYP‡	MAX	MIN	TYP‡	MAX	
$V_{IH}$	High-level input voltage		2			2			2			V
$V_{IL}$	Low-level input voltage		0.8			0.8			0.8			V
$V_{IK}$	Input clamp voltage	$V_{CC±} = \text{MIN}, I_I = -12 \text{ mA}$	-0.9	-1.5		-0.9	-1.5		-0.9	-1.5	V	
$I_{O(\text{on})}$	On-state output current	$V_{CC±} = \text{MAX}, V_O = 10 \text{ V}$	6	7		12	15		27	36	mA	
$I_{O(\text{off})}$	Off-state output current	$V_{CC±} = \text{MIN}, V_O = 10 \text{ V}$	3.5	6		6.5	12		18	27	µA	
$I_I$	Input current at maximum input voltage	A, B, or C inputs	1			1			1			mA
		D input	2			2			2			
$I_{IH}$	High-level input current	A, B, or C inputs	40			40			40			µA
		D input	80			80			80			
$I_{IL}$	Low-level input current	A, B, or C inputs	-3			-3			-3			mA
		D input	-6			-6			-6			
$I_{CC+ (\text{on})}$	Supply current from $V_{CC+}$ with driver enabled	$V_{CC±} = \text{MAX},$ A and B inputs at 0.4 V, C and D inputs at 2 V	18	30		23	35		25	40	mA	
$I_{CC- (\text{on})}$	Supply current from $V_{CC-}$ with driver enabled		-18	-30		-34	-50		-65	-100		
$I_{CC+ (\text{off})}$	Supply current from $V_{CC+}$ with driver inhibited	$V_{CC±} = \text{MAX},$	18			21			30			mA
$I_{CC- (\text{off})}$	Supply current from $V_{CC-}$ with driver inhibited	A, B, C, and D inputs at 0.4 V	-10			-17			-32			

† For conditions shown as MIN or MAX, use appropriate value specified under recommended operating conditions.

‡ All typical values are at  $V_{CC+} = 5 \text{ V}, V_{CC-} = -5 \text{ V}, T_A = 25^\circ\text{C}$ .

# TYPES SN55109A, SN55110A, SN75109A, SN75110A, SN75112

## DUAL LINE DRIVERS

switching characteristics,  $V_{CC+} = 5\text{ V}$ ,  $V_{CC-} = -5\text{ V}$ ,  $T_A = 25^\circ\text{C}$

PARAMETER §	FROM (INPUT)	TO (OUTPUT)	TEST CONDITIONS	MIN	TYP	MAX	UNIT
$t_{PLH}$	A or B	Y or Z	$C_L = 40\text{ pF}$ , $R_L = 50\ \Omega$ , See Figure 1		9	15	ns
$t_{PHL}$					9	15	ns
$t_{PLH}$	C or D	Y or Z			16	25	ns
$t_{PHL}$					13	25	ns

§  $t_{PLH}$  ≡ Propagation delay time, low-to-high-level output.  
 $t_{PHL}$  ≡ Propagation delay time, high-to-low-level output.

### PARAMETER MEASUREMENT INFORMATION

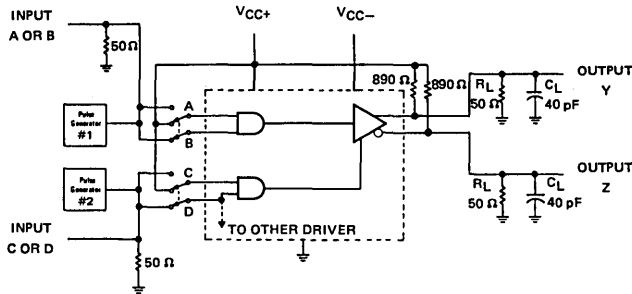

TEST CIRCUIT

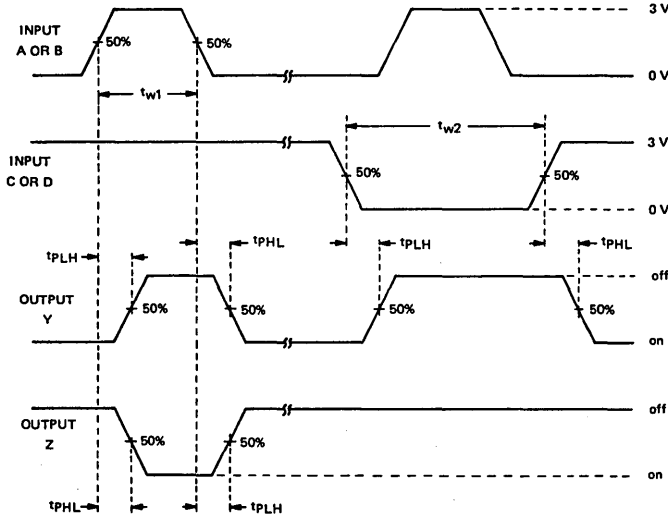

VOLTAGE WAVEFORMS

NOTES: A. The pulse generators have the following characteristics:  $Z_{out} = 50\ \Omega$ ,  $t_r = t_f = 10 \pm 5\text{ ns}$ ,  $t_{w1} = 500\text{ ns}$ ,  $PRR = 1\text{ MHz}$ ,  $t_{w2} = 1\ \mu\text{s}$ ,  $PRR = 500\text{ kHz}$ .  
 B.  $C_L$  includes probe and jig capacitance.  
 C. For simplicity, only one channel and the inhibitor connections are shown.

FIGURE 1—PROPAGATION DELAY TIMES



# TYPES SN55109A, SN55110A, SN75109A, SN75110A, SN75112 DUAL LINE DRIVERS

## TYPICAL CHARACTERISTICS

### ON-STATE OUTPUT CURRENT vs NEGATIVE SUPPLY VOLTAGE

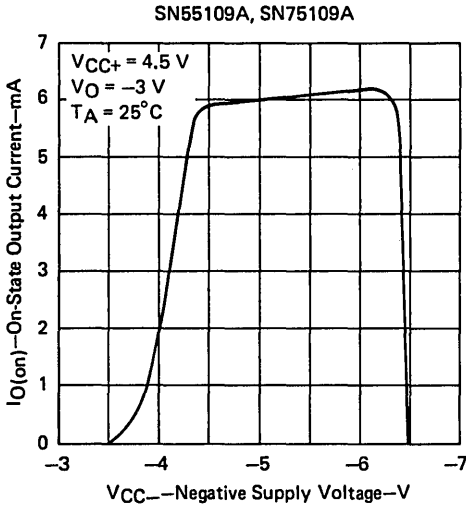

FIGURE 2

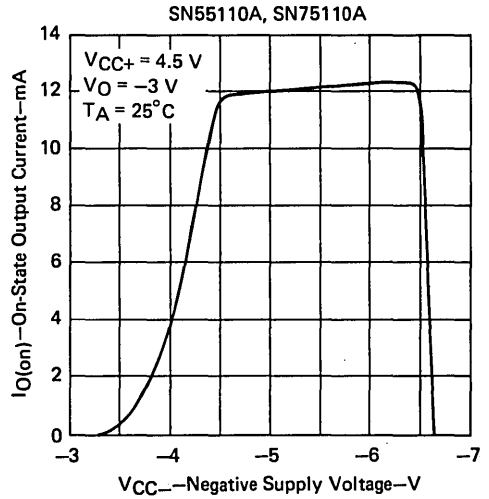

FIGURE 3

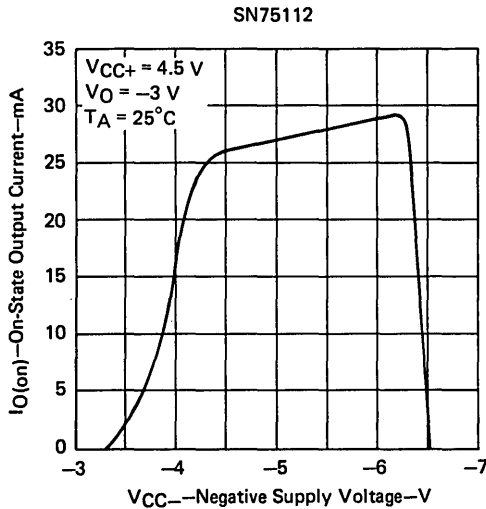

FIGURE 4

# TYPES SN55109A, SN55110A, SN75109A, SN75110A, SN75112 DUAL LINE DRIVERS

## TYPICAL APPLICATION INFORMATION

### basic balanced-line transmission system

The '109A, '110A, and SN75112 dual line drivers are designed specifically for use in high-speed data transmission systems that utilize balanced, terminated transmission lines such as twisted-pair lines. The system operates in the balanced mode, so that noise induced on one line is also induced on the other. The noise appears common-mode at the receiver input terminals, where it is rejected. The ground connection between the line driver and receiver is not part of the signal circuit so that system performance is not affected by circulating ground currents.

The unique driver-output circuit allows terminated transmission lines to be driven at normal line impedances. High-speed system operation is ensured since line reflections are virtually eliminated when terminated lines are used. Crosstalk is minimized by low signal amplitudes and low line impedances.

The typical data delay in a system is approximately  $(30 + 1.3L)$  nanoseconds, where  $L$  is the distance in feet

separating the driver and receiver. This delay includes one gate delay in both the driver and receiver.

Data is impressed on the balanced-line system by unbalancing the line voltages with the driver output current. The driven line is selected by appropriate driver-input logic levels. The voltage difference is approximately:  $V_{DIFF} \approx 1/2 I_{O(on)} \cdot R_T$

High series line resistance will cause degradation of the signal. However, line receivers such as the SN55107A, SN55108A, SN75107A, and SN75108A will detect signal as low as 25 mV (or less). For normal line resistances, data may be recovered from lines of several thousand feet in length.

Line-termination resistors ( $R_T$ ) are required only at the extreme ends of the line. For short lines, termination resistors at the receiver only may prove adequate. The signal amplitude will then be approximately:  $V_{DIFF} \approx I_{O(on)} \cdot R_T$

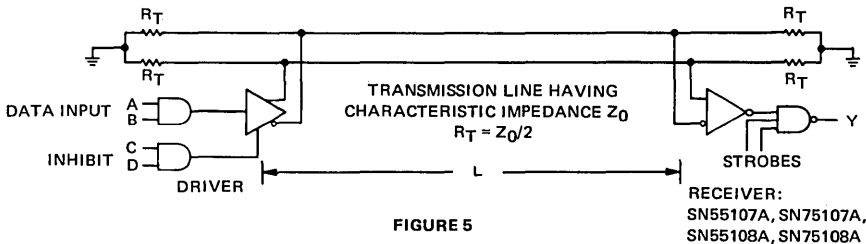

FIGURE 5

### data-bus or party-line system

The strobe feature of the '109A, '110A, and SN75112 line drivers allow these circuits to be used in data-bus or party-line systems. In these applications, several drivers and receivers may share a common transmission line. An enabled driver transmits data to all enabled receivers on the

line while other drivers are disabled. This series of drivers has been designed to allow widely varying thermal and electrical environments at the various terminal locations. The data-bus system offers maximum performance at minimum cost.

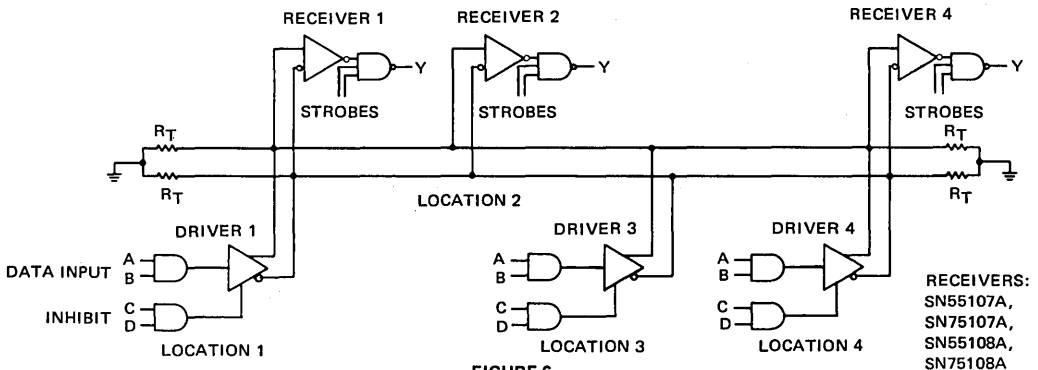

FIGURE 6

# TYPES SN55109A, SN55110A, SN75109A, SN75110A, SN75112 DUAL LINE DRIVERS

## TYPICAL APPLICATION DATA

### special pulse-control circuit

Figure 7 shows a circuit that may be used as a pulse generator output or in many other testing applications.

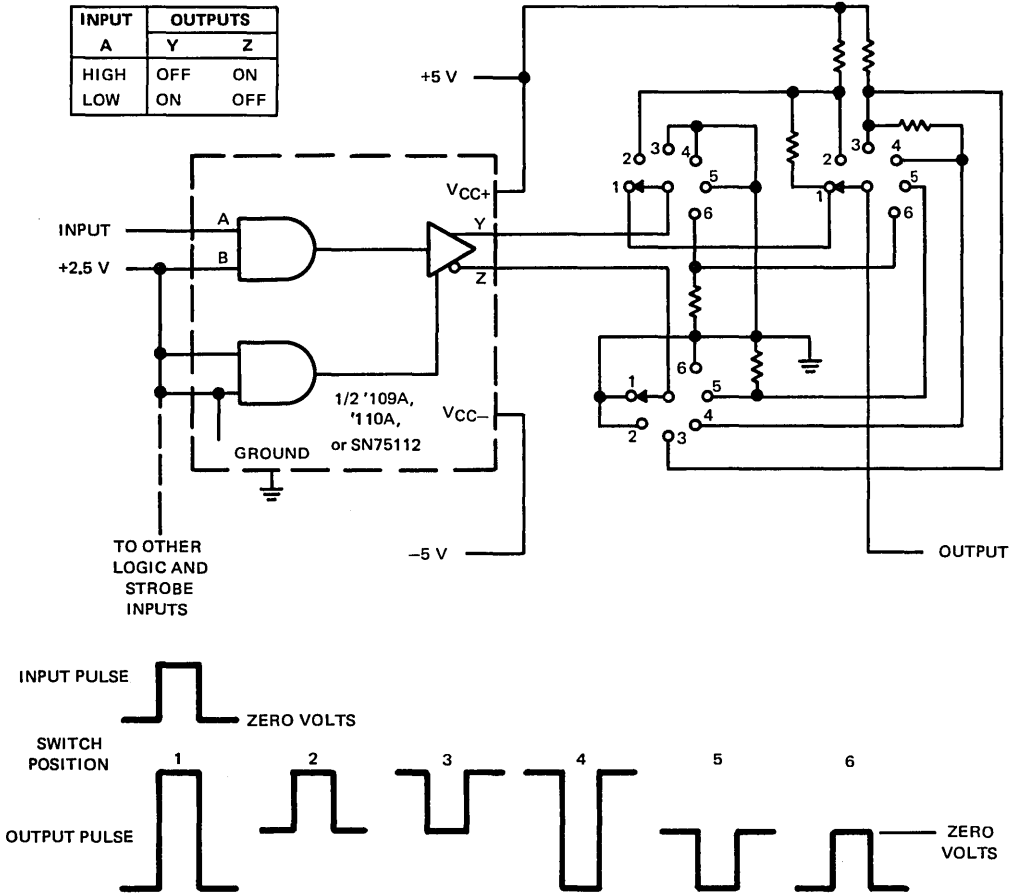

FIGURE 7—PULSE CONTROL CIRCUIT



# INTERFACE TYPES SN55113, SN55114, SN55115, SN75113, SN75114, SN75115 CIRCUITS DUAL DIFFERENTIAL DRIVERS AND RECEIVERS

BULLETIN NO. DL-S 11910, SEPTEMBER 1973—REVISED SEPTEMBER 1980

## LINE CIRCUITS featuring

- Each Circuit Offers Choice of Open-Collector or Active Pull-Up (Totem-Pole) Outputs
- Single 5-V Supply
- Differential Line Operation
- Dual Channels
- TTL/DTL Compatibility

### additional features of SN55113 and SN75113 line drivers with three-state outputs

- High-Impedance Output State for Party-Line Applications
- Short-Circuit Protection
- High-Current Outputs
- Single-Ended or Differential AND/NAND Outputs
- Common and Individual Output Controls
- Clamp Diodes at Inputs
- Easily Adaptable to SN55114 and SN75114 Applications

### additional features of SN55114 and SN75114 line drivers

- Designed to be Interchangeable with Fairchild 9614 Line Drivers
- Short-Circuit Protection of Outputs
- High-Current Outputs
- Clamp Diodes at Inputs and Outputs to Terminate Line Transients
- Single-Ended or Differential AND/NAND Outputs
- Triple Inputs

### additional features of SN55115 and SN75115 line receivers

- Designed to be interchangeable with Fairchild 9615 Line Receivers
- $\pm 15$  V Common-Mode Input Voltage Range
- Optional-Use Built-In  $130\text{-}\Omega$  Line-Terminating Resistor
- Individual Frequency Response Controls
- Individual Channel Strobes

## CONTENTS

	PAGE
<b>SN55113, SN75113 Line Drivers</b>	
Description, Function Table, Schematic, and Maximum Ratings . . . . .	5-70
Recommended Operating Conditions and Electrical Characteristics . . . . .	5-71
Switching Characteristics and Parameter Measurement Information . . . . .	5-72
Typical Characteristics . . . . .	5-73
<b>SN55114, SN75114 Line Drivers</b>	
Description, Function Table, Schematic, and Maximum Ratings . . . . .	5-76
Recommended Operating Conditions, Electrical Characteristics and Switching Characteristics . . . . .	5-77
Parameter Measurement Information and Typical Characteristics . . . . .	5-78
<b>SN55115, SN75115 Line Receivers</b>	
Description, Function Table, Schematic, and Maximum Ratings . . . . .	5-80
Recommended Operating Conditions, Electrical Characteristics . . . . .	5-81
Switching Characteristics, Parameter Measurement Information, and Typical Characteristics . . . . .	5-82
Typical Application Data . . . . .	5-86

# TYPES SN55113, SN75113

## DUAL DIFFERENTIAL LINE DRIVERS WITH 3-STATE OUTPUTS

### description

The SN55113 and SN75113 dual differential line drivers with three-state outputs are designed to provide all the features of the SN55114 and SN75114 line drivers with the added feature of driver output controls. There are individual controls for each output pair, as well as a common control for both output pairs. When an output control is low, the associated output is in a high-impedance state and the output can neither drive nor load the bus. This permits many devices to be connected together on the same transmission line for party-line applications.

The output stages are similar to TTL totem-pole outputs, but with the sink outputs, YS and ZS, and the corresponding active pull-up terminals, YP and ZP, available on adjacent package pins.

FUNCTION TABLE						
INPUTS			OUTPUTS			
OUTPUT CONTROL	DATA	AND	NAND	Y	Z	
C	CC	A	B†	Y	Z	
L	X	X	X	Z	Z	
X	L	X	X	Z	Z	
H	H	L	X	L	H	
H	H	X	L	L	H	
H	H	H	H	H	L	

H = high level, L = low level, X = irrelevant, Z = high impedance (off)  
 †B input and 4th line of function table applicable only to driver number 1.

J OR N DUAL-IN-LINE PACKAGE  
(TOP VIEW)

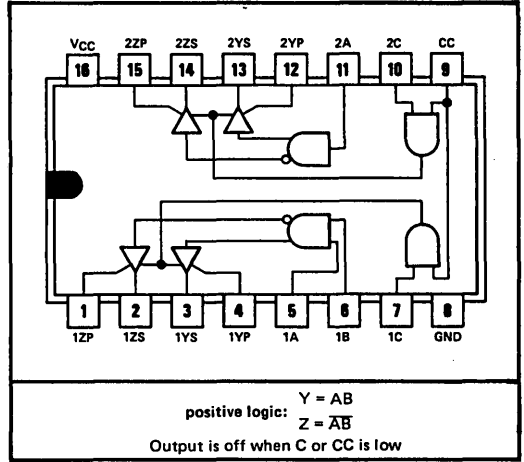

5

### schematic

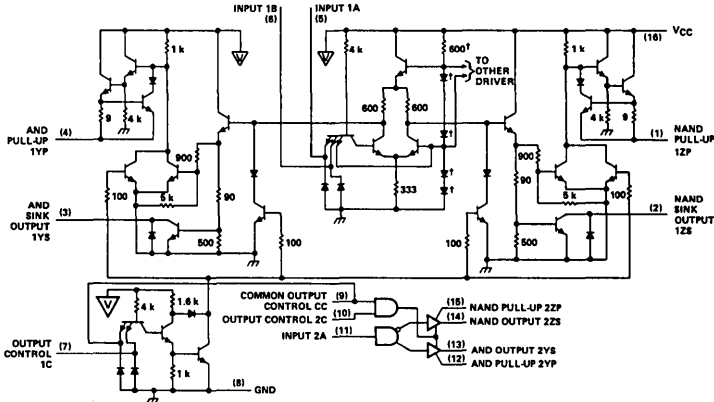

▽ ... VCC bus

Resistor values shown are nominal and in ohms.

† These components common to both drivers.

### absolute maximum ratings over operating free-air temperature (unless otherwise noted)

Supply voltage, VCC (see Note 1)	7 V
Input voltage	5.5 V
Off-state voltage applied to open-collector outputs	12 V
Continuous total dissipation at (or below) 25°C free-air temperature (see Note 2)	1 W
Operating free-air temperature range: SN55113	-55°C to 125°C
SN75113	0°C to 70°C
Storage temperature range	-65°C to 150°C
Lead temperature 1/16 inch from case for 60 seconds: J package	300°C
Lead temperature 1/16 inch from case for 10 seconds: N package	260°C

- NOTES: 1. All voltage values are with respect to network ground terminal.  
 2. For operation above 25°C free-air temperature, refer to Dissipation Derating Curves in the Thermal Information section, which starts on page 2-1. In the J package, SN55113 chips are alloy-mounted; SN75113 chips are glass-mounted.

# TYPES SN55113, SN75113

## DUAL DIFFERENTIAL LINE DRIVERS WITH 3-STATE OUTPUTS

REVISED SEPTEMBER 1980

### recommended operating conditions

	SN55113			SN75113			UNIT
	MIN	NOM	MAX	MIN	NOM	MAX	
Supply voltage, $V_{CC}$	4.5	5	5.5	4.75	5	5.25	V
High-level output current, $I_{OH}$			-40			-40	mA
Low-level output current, $I_{OL}$			40			40	mA
Operating free-air temperature, $T_A$	-55		125	0		70	°C

### electrical characteristics over recommended operating free-air temperature range (unless otherwise noted)

PARAMETER		TEST CONDITIONS†		SN55113		SN75113		UNIT		
				MIN	TYP‡	MAX	MIN		TYP‡	MAX
$V_{IH}$	High-level input voltage			2		2		V		
$V_{IL}$	Low-level input voltage				0.8		0.8	V		
$V_{IK}$	Input clamp voltage	$V_{CC} = \text{MIN}, I_I = -12 \text{ mA}$		-0.9	-1.5	-0.9	-1.5	V		
$V_{OH}$	High-level output voltage	$V_{CC} = \text{MIN}, V_{IL} = 0.8 \text{ V}$	$V_{IH} = 2 \text{ V}, I_{OH} = -10 \text{ mA}$	2.4	3.4	2.4	3.4	V		
			$I_{OH} = -40 \text{ mA}$	2	3.0	2	3.0			
$V_{OL}$	Low-level output voltage	$V_{CC} = \text{MIN}, V_{IL} = 0.8 \text{ V}$	$V_{IH} = 2 \text{ V}, I_{OL} = 40 \text{ mA}$	0.23	0.4	0.23	0.4	V		
$V_{OK}$	Output clamp voltage	$V_{CC} = \text{MAX}, I_O = -40 \text{ mA}$		-1.1	-1.5	-1.1	-1.5	V		
$I_{O(\text{off})}$	Off-state open-collector output current	$V_{CC} = \text{MAX}$	$V_{OH} = 12 \text{ V}$	$T_A = 25^\circ\text{C}$	1	10		$\mu\text{A}$		
				$T_A = 125^\circ\text{C}$		200				
			$V_{OH} = 5.25 \text{ V}$	$T_A = 25^\circ\text{C}$			1		10	
				$T_A = 70^\circ\text{C}$					20	
$I_{OZ}$	Off-state (high-impedance-state) output current	$V_{CC} = \text{MAX},$ Output controls at 0.8 V	$T_A = \text{MAX}$	$T_A = 25^\circ\text{C}, V_O = 0 \text{ to } V_{CC}$		$\pm 10$	$\pm 10$	$\mu\text{A}$		
				$V_O = 0$		-150	-20			
				$V_O = 0.4 \text{ V}$		$\pm 80$	$\pm 20$			
				$V_O = 2.4 \text{ V}$		$\pm 80$	$\pm 20$			
				$V_O = V_{CC}$		80	20			
$I_I$	Input current at maximum input voltage	A, B, C	$V_{CC} = \text{MAX}, V_I = 5.5 \text{ V}$		1		1	mA		
		CC			2		2			
$I_{IH}$	High-level input current	A, B, C	$V_{CC} = \text{MAX}, V_I = 2.4 \text{ V}$		40		40	$\mu\text{A}$		
		CC			80		80			
$I_{IL}$	Low-level input current	A, B, C	$V_{CC} = \text{MAX}, V_I = 0.4 \text{ V}$		-1.6		-1.6	mA		
		CC			-3.2		-3.2			
$I_{OS}$	Short-circuit output current§	$V_{CC} = \text{MAX}, V_O = 0,$	$T_A = 25^\circ\text{C}$	-40	-90	-120	-40	-90	-120	mA
$I_{CC}$	Supply current (both drivers)	All inputs at 0 V, No load, $T_A = 25^\circ\text{C}$		$V_{CC} = \text{MAX}$	47	65	47	65	mA	
				$V_{CC} = 7 \text{ V}$	65	85	65	85		

† All parameters with the exception of off-state open-collector output current are measured with the active pull-up connected to the sink output.

‡ All typical values are at  $T_A = 25^\circ\text{C}$  and  $V_{CC} = 5 \text{ V}$ , with the exception of  $I_{CC}$  at 7 V.

§ Only one output should be shorted at a time, and duration of the short-circuit should not exceed one second.

5

# TYPES SN55113, SN75113

## DUAL DIFFERENTIAL LINE DRIVERS WITH 3-STATE OUTPUTS

switching characteristics,  $V_{CC} = 5\text{ V}$ ,  $C_L = 30\text{ pF}$ ,  $T_A = 25^\circ\text{ C}$

PARAMETER	TEST CONDITIONS	SN55113			SN75113			UNIT
		MIN	TYP	MAX	MIN	TYP	MAX	
$t_{PLH}$ Propagation delay time, low-to-high-level output	See Figure 1	13	20	13	30	ns		
$t_{PHL}$ Propagation delay time, high-to-low-level output		12	20	12	30	ns		
$t_{PZH}$ Output enable time to high level	$R_L = 180\ \Omega$ , See Figure 2	7	15	7	20	ns		
$t_{PZL}$ Output enable time to low level	$R_L = 250\ \Omega$ , See Figure 3	14	30	14	40	ns		
$t_{PHZ}$ Output disable time from high level	$R_L = 180\ \Omega$ , See Figure 2	10	20	10	30	ns		
$t_{PLZ}$ Output disable time from low level	$R_L = 250\ \Omega$ , See Figure 3	17	35	17	35	ns		

### PARAMETER MEASUREMENT INFORMATION

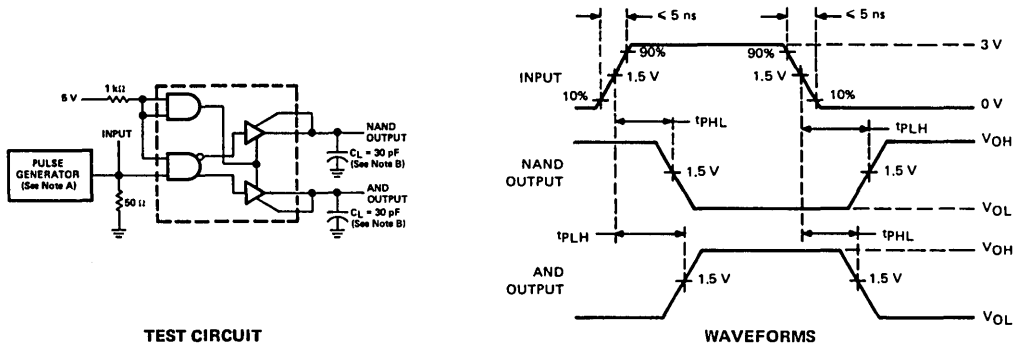

FIGURE 1— $t_{PLH}$  and  $t_{PHL}$

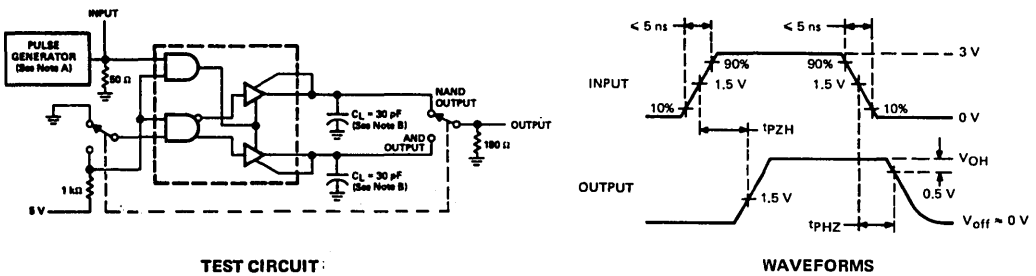

FIGURE 2— $t_{PZH}$  and  $t_{PHZ}$

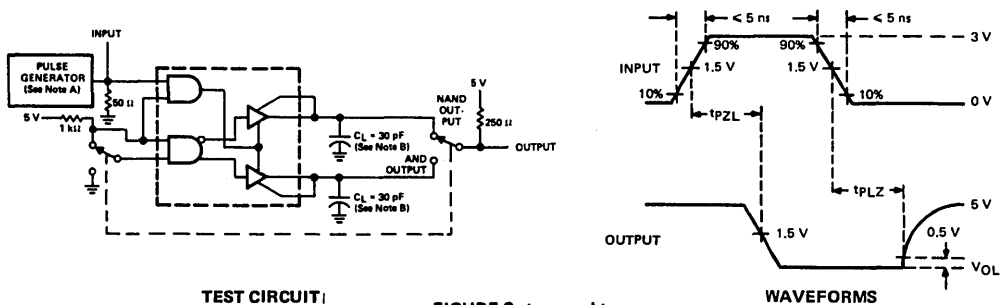

FIGURE 3— $t_{PZL}$  and  $t_{PLZ}$

NOTES: A. The pulse generator has the following characteristics:  $Z_{out} = 50\ \Omega$ ,  $PRR = 500\text{ kHz}$ ,  $t_w = 100\text{ ns}$ .  
 B.  $C_L$  includes probe and jig capacitance.



# TYPES SN55113, SN75113 DUAL DIFFERENTIAL LINE DRIVERS WITH 3-STATE OUTPUTS

## TYPICAL CHARACTERISTICS†

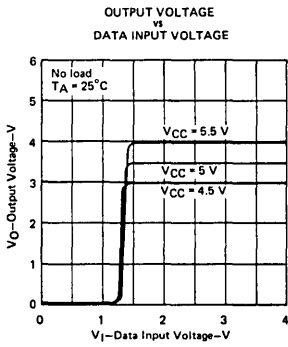

FIGURE 4

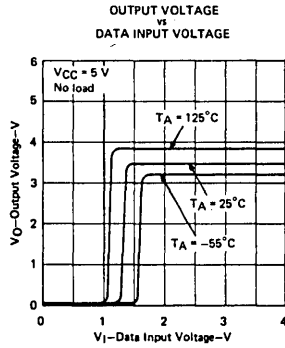

FIGURE 5

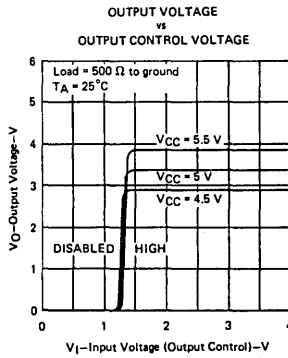

FIGURE 6

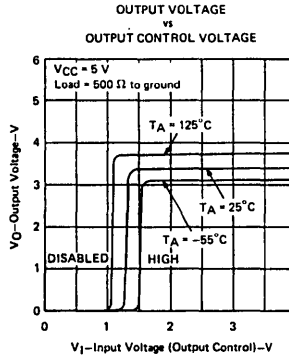

FIGURE 7

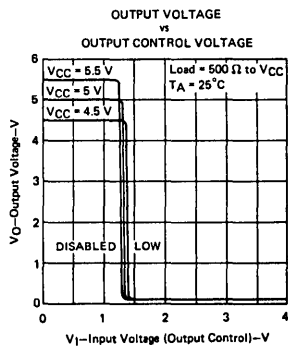

FIGURE 8

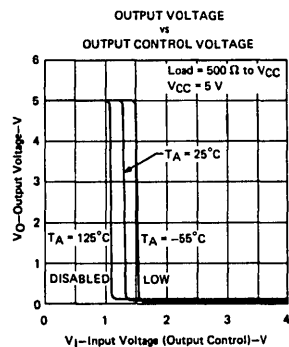

FIGURE 9

†Data for temperatures below  $0^\circ\text{C}$  and above  $70^\circ\text{C}$  and for supply voltages below 4.75 V and above 5.25 V are applicable to SN55113 circuits only. These parameters were measured with the active pull-up connected to the sink output.

# TYPES SN55113, SN75113

## DUAL DIFFERENTIAL LINE DRIVERS WITH 3-STATE OUTPUTS

### TYPICAL CHARACTERISTICS†

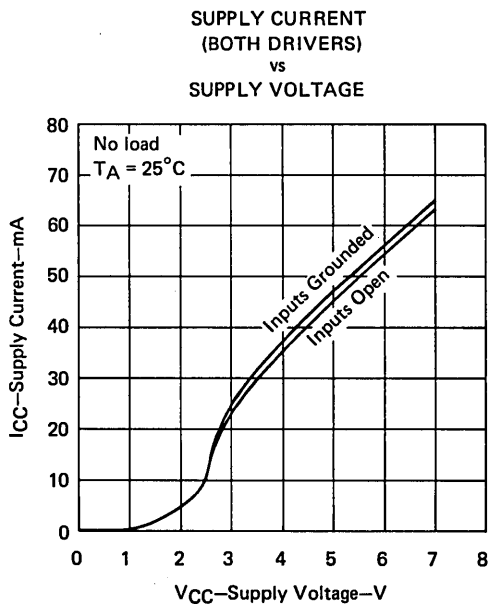
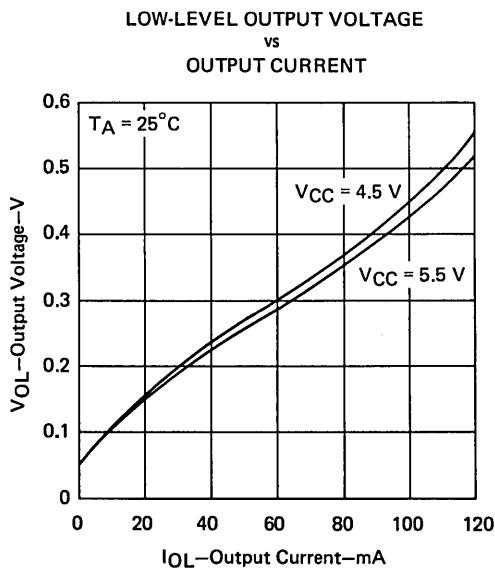
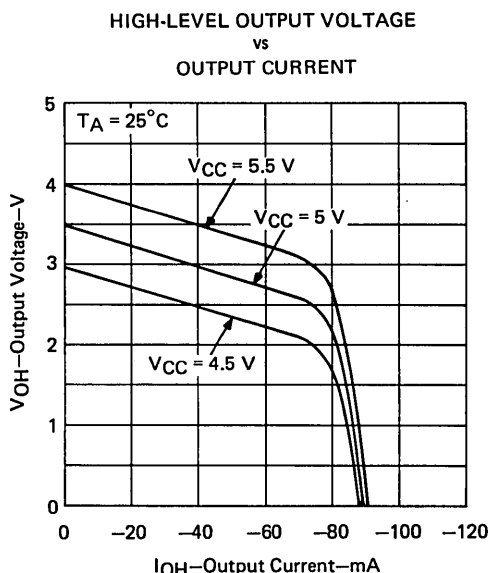
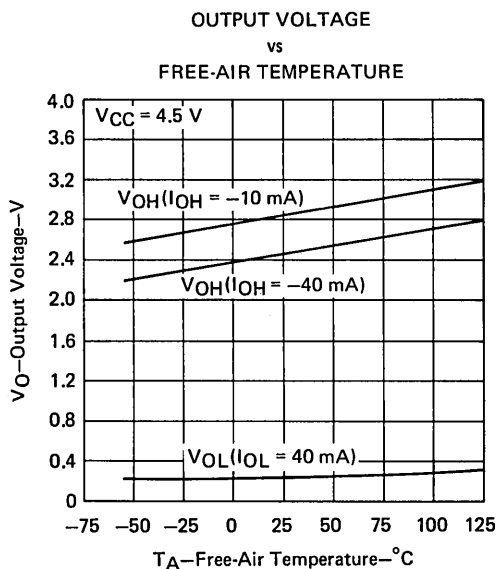

† Data for temperature below  $0^\circ\text{C}$  and above  $70^\circ\text{C}$  and for supply voltages below  $4.75 \text{ V}$  and above  $5.25 \text{ V}$  are applicable to SN55113 circuits only. These parameters were measured with the active pull-up connected to the sink output.

# TYPES SN55113, SN75113

## DUAL DIFFERENTIAL LINE DRIVERS WITH 3-STATE OUTPUTS

### TYPICAL CHARACTERISTICS†

SUPPLY CURRENT  
(BOTH DRIVERS)  
vs  
FREE-AIR TEMPERATURE

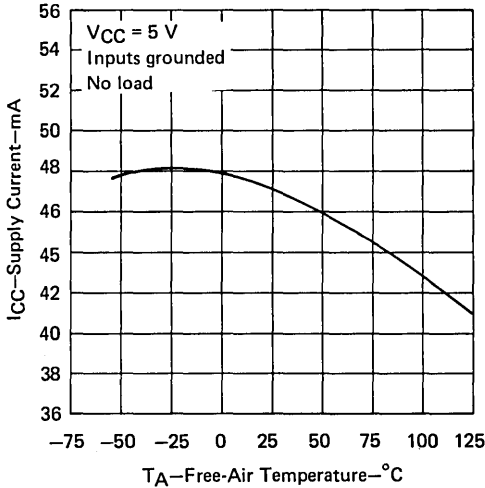

FIGURE 14

SUPPLY CURRENT  
(BOTH DRIVERS)  
vs  
FREQUENCY

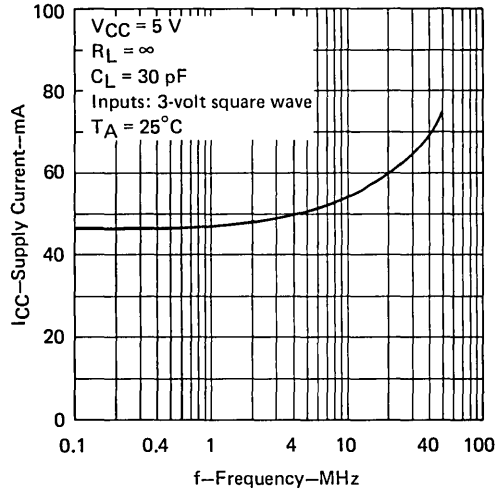

FIGURE 15

PROPAGATION DELAY TIMES  
FROM DATA INPUTS  
vs  
FREE-AIR TEMPERATURE

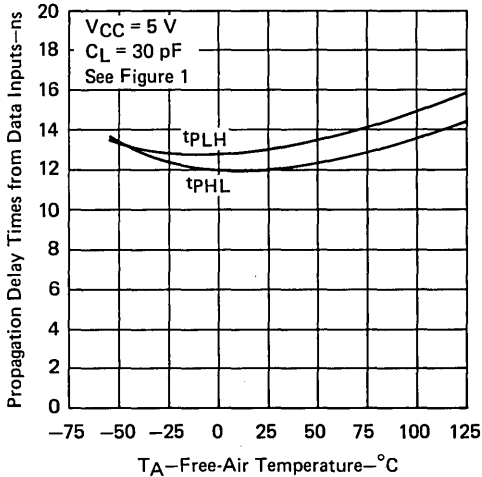

FIGURE 16

OUTPUT ENABLE and DISABLE TIMES  
vs  
FREE-AIR TEMPERATURE

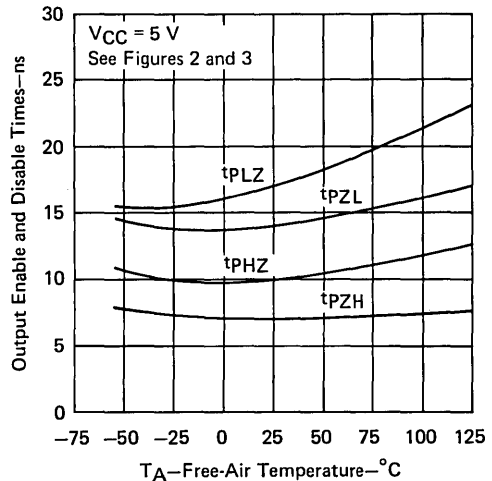

FIGURE 17

† Data for temperature below 0 °C and above 70 °C and for supply voltages below 4.75 V and above 5.25 V are applicable to SN55113 circuits only. These parameters were measured with the active pull-up connected to the sink output.

# TYPES SN55114, SN75114

## DUAL DIFFERENTIAL LINE DRIVERS

### description

The SN55114 and SN75114 dual differential line drivers are designed to provide differential output signals with high current capability for driving balanced lines, such as twisted-pair at normal line impedances, without high power dissipation. The output stages are similar to TTL totem-pole outputs, but with the sink outputs, YS and ZS, and the corresponding active pull-up terminals, YP and ZP, available on adjacent package pins. Since the output stages provide TTL compatible output levels, these devices may also be used as TTL expanders or phase splitters.

FUNCTION TABLE				
INPUTS			OUTPUTS	
A	B	C	Y	Z
H	H	H	H	L
ALL OTHER INPUT COMBINATIONS			L	H

H = high level, L = low level

J OR N DUAL-IN-LINE PACKAGE  
(TOP VIEW)

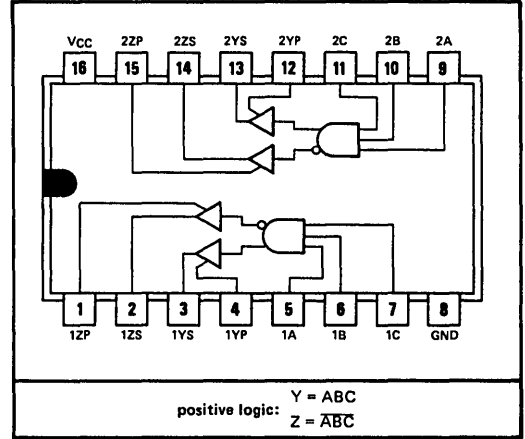

5

### schematic (each driver)

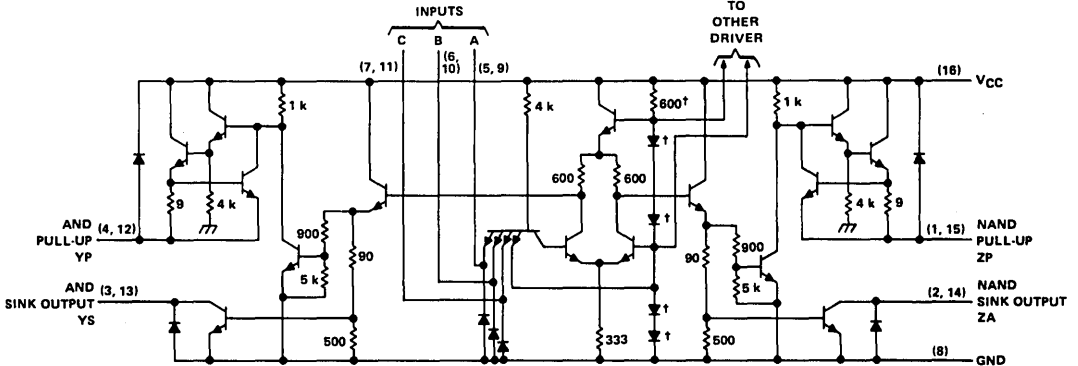

† These components common to both drivers.  
Resistor values shown are nominal and in ohms.

### absolute maximum ratings over operating free-air temperature range (unless otherwise noted)

Supply voltage, $V_{CC}$ (see Note 1)	7 V
Input voltage	5.5 V
Off-state voltage applied to open-collector outputs	12 V
Continuous total dissipation at (or below) 25°C free-air temperature (see Note 2)	1 W
Operating free-air temperature range: SN55114	-55°C to 125°C
SN75114	0°C to 70°C
Storage temperature range	-65°C to 150°C
Lead temperature 1/16 inch from case for 60 seconds: J package	300°C
Lead temperature 1/16 inch from case for 10 seconds: N package	260°C

NOTES: 1. All voltage values are with respect to network ground terminal.

2. For operation above 25°C free-air temperature, refer to Dissipation Derating Curves in the Thermal Information section, which starts on page 2-1. In the J package, SN55114 chips are alloy-mounted; SN75114 chips are glass-mounted.

# TYPES SN55114, SN75114 DUAL DIFFERENTIAL LINE DRIVERS

REVISED SEPTEMBER 1980

## recommended operating conditions

	SN55114			SN75114			UNIT
	MIN	NOM	MAX	MIN	NOM	MAX	
Supply voltage, $V_{CC}$	4.5	5	5.5	4.75	5	5.25	V
High-level output current, $I_{OH}$			-40			-40	mA
Low-level output current, $I_{OL}$			40			40	mA
Operating free-air temperature, $T_A$	-55		125	0		70	$^{\circ}$ C

## electrical characteristics over recommended operating free-air temperature range (unless otherwise noted)

PARAMETER	TEST CONDITIONS†	SN55114			SN75114			UNIT
		MIN	TYP‡	MAX	MIN	TYP‡	MAX	
$V_{IH}$ High-level input voltage		2			2			V
$V_{IL}$ Low-level input voltage				0.8			0.8	
$V_{IK}$ Input clamp voltage	$V_{CC} = \text{MIN}$ , $I_I = -12 \text{ mA}$	-0.9	-1.5		-0.9	-1.5		V
$V_{OH}$ High-level output voltage	$V_{CC} = \text{MIN}$ , $V_{IH} = 2 \text{ V}$ , $V_{IL} = 0.8 \text{ V}$ , $I_{OH} = -10 \text{ mA}$	2.4	3.4		2.4	3.4		V
	$I_{OH} = -40 \text{ mA}$	2	3.0		2	3.0		
$V_{OL}$ Low-level output voltage	$V_{CC} = \text{MIN}$ , $V_{IH} = 2 \text{ V}$ , $V_{IL} = 0.8 \text{ V}$ , $I_{OL} = 40 \text{ mA}$	0.2	0.4		0.2	0.45		V
$V_{OK}$ Output clamp voltage	$V_{CC} = 5 \text{ V}$ , $I_O = 40 \text{ mA}$ , $T_A = 25^{\circ}\text{C}$	6.1	6.5		6.1	6.5		V
	$V_{CC} = \text{MAX}$ , $I_O = -40 \text{ mA}$ , $T_A = 25^{\circ}\text{C}$	-1.1	-1.5		-1.1	-1.5		
$I_{O(\text{off})}$ Off-state open-collector output current	$V_{CC} = \text{MAX}$							$\mu\text{A}$
	$V_{OH} = 12 \text{ V}$ , $T_A = 25^{\circ}\text{C}$		1	100				
	$T_A = 125^{\circ}\text{C}$			200				
	$V_{OH} = 5.25 \text{ V}$ , $T_A = 25^{\circ}\text{C}$				1	100		
	$T_A = 70^{\circ}\text{C}$					200		
$I_I$ Input current at maximum input voltage	$V_{CC} = \text{MAX}$ , $V_I = 5.5 \text{ V}$			1			1	mA
$I_{IH}$ High-level input current	$V_{CC} = \text{MAX}$ , $V_I = 2.4 \text{ V}$			40			40	$\mu\text{A}$
$I_{IL}$ Low-level input current	$V_{CC} = \text{MAX}$ , $V_I = 0.4 \text{ V}$	-1.1	-1.6		-1.1	-1.6		mA
$I_{OS}$ Short-circuit output current§	$V_{CC} = \text{MAX}$ , $V_O = 0$ , $T_A = 25^{\circ}\text{C}$	-40	-90	-120	-40	-90	-120	mA
$I_{CC}$ Supply current (both drivers)	All inputs at 0 V, No load, $T_A = 25^{\circ}\text{C}$							mA
	$V_{CC} = \text{MAX}$		37	50		37	50	
	$V_{CC} = 7 \text{ V}$		47	65		47	70	

† All parameters, with the exception of off-state open-collector output current, are measured with the active pull-up connected to the sink output.

‡ All typical values are at  $T_A = 25^{\circ}\text{C}$  and  $V_{CC} = 5 \text{ V}$ , with the exception of  $I_{CC}$  at 7 V.

§ Only one output should be shorted at a time, and duration of the short-circuit should not exceed one second.

## switching characteristics, $V_{CC} = 5 \text{ V}$ , $T_A = 25^{\circ}\text{C}$

PARAMETER	TEST CONDITIONS	SN55114			SN75114			UNIT
		MIN	TYP	MAX	MIN	TYP	MAX	
$t_{PLH}$ Propagation delay time, low-to-high-level output	$C_L = 30 \text{ pF}$		15	20		15	30	ns
$t_{PHL}$ Propagation delay time, high-to-low-level output	See Figure 18		11	20		11	30	ns

**TEXAS INSTRUMENTS**  
INCORPORATED

POST OFFICE BOX 225012 • DALLAS, TEXAS 75265

# TYPES SN55114, SN75114 DUAL DIFFERENTIAL LINE DRIVERS

## PARAMETER MEASUREMENT INFORMATION

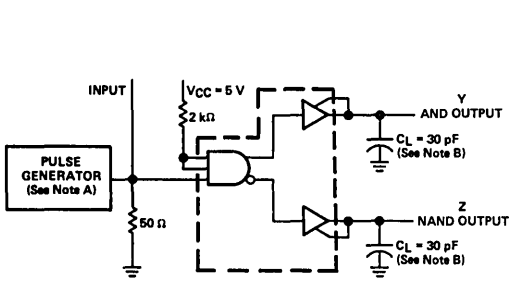

TEST CIRCUIT

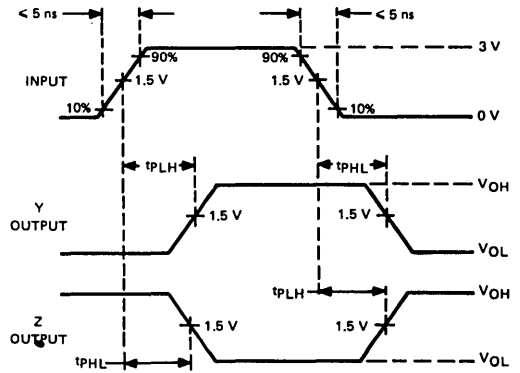

VOLTAGE WAVEFORMS

NOTES: A. The pulse generator has the following characteristics:  $Z_{out} = 50\ \Omega$ ,  $t_w = 100\text{ ns}$ ,  $PRR = 500\text{ kHz}$ .  
B.  $C_L$  includes probe and jig capacitance.

FIGURE 18—PROPAGATION DELAY TIMES

## TYPICAL CHARACTERISTICS†

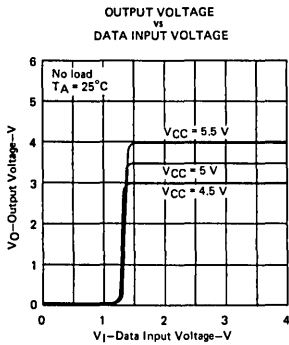

FIGURE 19

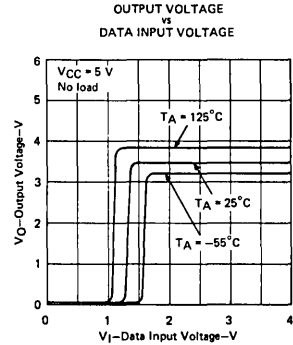

FIGURE 20

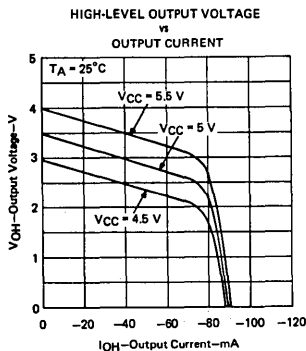

FIGURE 21

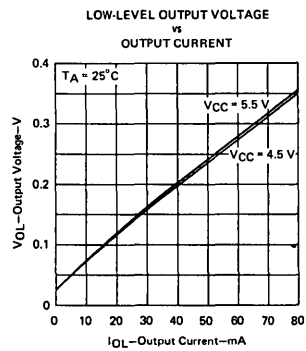

FIGURE 22

† Data for temperatures below  $0^\circ\text{C}$  and above  $70^\circ\text{C}$  and for supply voltages below  $4.75\text{ V}$  and above  $5.25\text{ V}$  are applicable to SN55114 circuits only. These parameters were measured with the active pull-up connected to the sink output.

# TYPES SN55114, SN75114 DUAL DIFFERENTIAL LINE DRIVERS

## TYPICAL CHARACTERISTICS†

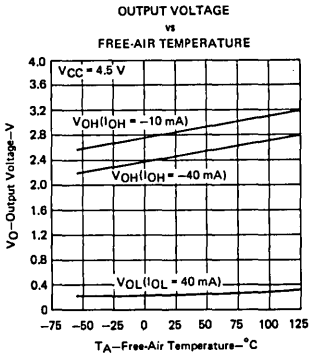

FIGURE 23

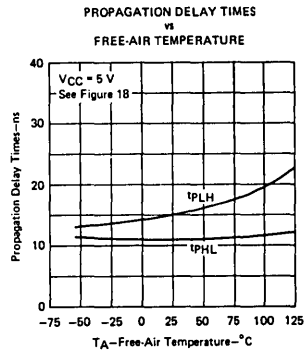

FIGURE 24

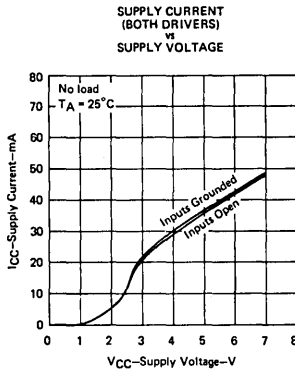

FIGURE 25

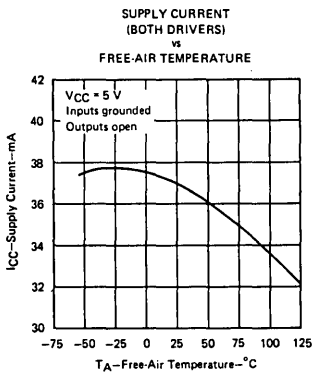

FIGURE 26

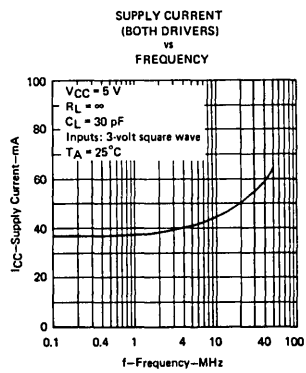

FIGURE 27

†Data for temperatures below 0°C and above 70°C are applicable to SN55114 circuits only. These parameters were measured with the active pull-up connected to the sink output.

5

# TYPES SN55115, SN75115 DUAL DIFFERENTIAL LINE RECEIVERS

## description

The SN55115 and SN75115 dual differential line receivers are designed to sense small differential signals in the presence of large common-mode noise. These devices give TTL-compatible output signals as a function of the polarity of the differential input voltage. The open-collector output configuration permits the wire-AND connection with similar outputs (such as SN5401/SN7401 TTL gates or other SN55115/SN75115 line receivers). This permits a level of logic to be implemented without extra delay. The output stages are similar to TTL totem-pole outputs, but with the sink outputs, 1YS and 2YS, and the corresponding active pull-up terminals, 1YP and 2YP, available on adjacent package pins. The frequency response of each channel may be easily controlled by a single external capacitor to provide immunity to differential noise spikes. A strobe input is provided for each channel. With the strobe in the low level, the receiver is disabled and the outputs are forced to a high level.

J OR N DUAL-IN-LINE PACKAGE  
(TOP VIEW)

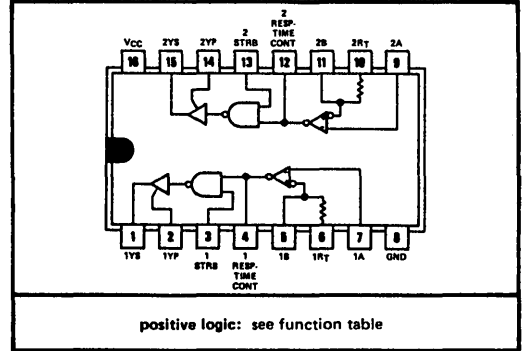

positive logic: see function table

FUNCTION TABLE

STROBE	DIFF INPUT	OUTPUT
L	X	H
H	L	H
H	H	L

H =  $V_I > V_{IH}$  min or  $V_{ID}$  more positive than  $V_{TH}$  max  
L =  $V_I < V_{IL}$  max or  $V_{ID}$  more negative than  $V_{TL}$  max  
X = irrelevant

## schematic (each receiver)

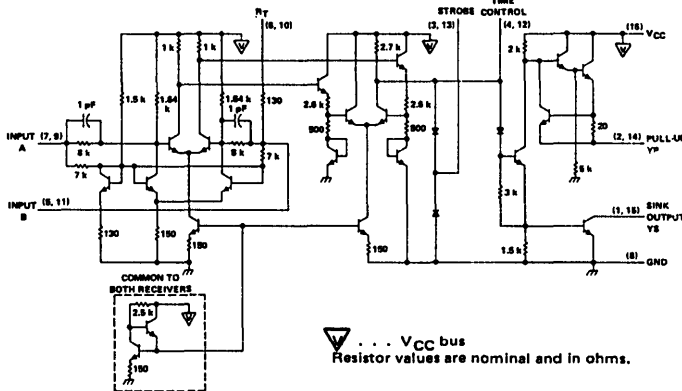

... VCC bus  
Resistor values are nominal and in ohms.

## absolute maximum ratings over operating free-air temperature range (unless otherwise noted)

Supply voltage, $V_{CC}$ (see Note 1)	7 V
Input voltage at A, B, and $R_T$ inputs	$\pm 25$ V
Input voltage at strobe input	5.5 V
Off-state voltage applied to open-collector outputs	14 V
Continuous total dissipation at (or below 25°C free-air temperature (see Note 2)	1 W
Operating free-air temperature range: SN55115	-55°C to 125°C
SN75115	0°C to 70°C
Storage temperature range	-65°C to 150°C
Lead temperature 1/16 inch from case for 60 seconds: J package	300°C
Lead temperature 1/16 inch from case for 10 seconds: N package	260°C

- NOTES: 1. All voltage values, except differential input voltage, are with respect to network ground terminal.  
2. For operation above 25°C free-air temperature, refer to Dissipation Derating Curves in the Thermal Information section, which starts on page 2-1. In the J package, SN55115 chips are alloy-mounted; SN75115 chips are glass-mounted.



# TYPES SN55115, SN75115 DUAL DIFFERENTIAL LINE RECEIVERS

## recommended operating conditions

	SN55115			SN75115			UNIT
	MIN	NOM	MAX	MIN	NOM	MAX	
Supply voltage, $V_{CC}$	4.5	5	5.5	4.75	5	5.25	V
High-level output current, $I_{OH}$				-5			mA
Low-level output current, $I_{OL}$				15			mA
Operating free-air temperature, $T_A$	-55		125	0		70	°C

## electrical characteristics over recommended operating free-air temperature range (unless otherwise noted)

PARAMETER	TEST CONDITIONS†	SN55115			SN75115			UNIT				
		MIN	TYP‡	MAX	MIN	TYP‡	MAX					
$V_{TH}$ §	Differential input high-threshold voltage	$V_O = 0.4$ V, $I_{OL} = 15$ mA, $V_{IC} = 0$			500			mV				
$V_{TL}$ §	Differential input low-threshold voltage	$V_O = 2.4$ V, $I_{OH} = -5$ mA, $V_{IC} = 0$			-500¶			mV				
$V_{ICR}$	Common-mode input voltage range	$V_{ID} = \pm 1$ V			+15 to -15	+24 to -19	+15 to -15	V				
$V_{IH(strobe)}$	High-level strobe input voltage				2.4			V				
$V_{IL(strobe)}$	Low-level strobe input voltage				0.4			V				
$V_{OH}$	High-level output voltage	$V_{CC} = \text{MIN}$ , $I_{OH} = -5$ mA	$V_{ID} = -0.5$ V,	$T_A = \text{MIN}$	2.2		2.4		V			
				$T_A = 25^\circ\text{C}$	2.4	3.4	2.4	3.4				
				$T_A = \text{MAX}$	2.4		2.4					
$V_{OL}$	Low-level output voltage	$V_{CC} = \text{MIN}$ , $I_{OL} = 15$ mA	$V_{ID} = 0.5$ V,	0.22	0.4	0.22	0.45	V				
$I_{IL}$	Low-level input current	$V_{CC} = \text{MAX}$ , Other Input at 5.5 V	$V_I = 0.4$ V,	$T_A = \text{MIN}$			-0.9		mA			
				$T_A = 25^\circ\text{C}$	-0.5	-0.7	-0.5	-0.7				
				$T_A = \text{MAX}$	-0.7		-0.7					
$I_{SH}$	High-level strobe current	$V_{CC} = \text{MIN}$ , $V_{strobe} = 4.5$ V	$V_{ID} = -0.5$ V,	$T_A = 25^\circ\text{C}$	2		5		$\mu\text{A}$			
				$T_A = \text{MAX}$	5		10					
$I_{SL}$	Low-level strobe current	$V_{CC} = \text{MAX}$ , $V_{strobe} = 0.4$ V	$V_{ID} = 0.5$ V,	$T_A = 25^\circ\text{C}$		-1.15 -2.4		mA				
$I_4, I_{12}$	Response-time-control current (Pin 4 or Pin 12)	$V_{CC} = \text{MAX}$ , $V_{RC} = 0$	$V_{ID} = 0.5$ V,	$T_A = 25^\circ\text{C}$		-1.2 -3.4		mA				
$I_{O(off)}$	Off-state open-collector output current	$V_{CC} = \text{MIN}$ , $V_{ID} = -4.5$ V	$V_{OH} = 12$ V,	$T_A = 25^\circ\text{C}$	100				$\mu\text{A}$			
				$T_A = \text{MAX}$	200							
		$V_{CC} = \text{MIN}$ , $V_{ID} = -4.75$ V	$V_{OH} = 5.25$ V,	$T_A = 25^\circ\text{C}$			100					
				$T_A = \text{MAX}$			200					
$R_T$	Line-terminating resistance	$V_{CC} = 5$ V		$T_A = 25^\circ\text{C}$		77	130	167	74	130	179	$\Omega$
$I_{OS}$	Short-circuit output current*	$V_{CC} = \text{MAX}$ , $V_{ID} = -0.5$ V	$V_O = 0$ ,	$T_A = 25^\circ\text{C}$		-15	-40	-80	-14	-40	-100	mA
$I_{CC}$	Supply current (both receivers)	$V_{CC} = \text{MAX}$ , $V_{IC} = 0$	$V_{ID} = 0.5$ V	$T_A = 25^\circ\text{C}$		32		50	32		50	mA

† Unless otherwise noted  $V_{strobe} = 2.4$  V. All parameters with the exception of off-state open-collector output current are measured with the active pull-up connected to the sink output.

‡ All typical values are at  $V_{CC} = 5$  V,  $T_A = 25^\circ\text{C}$ , and  $V_{IC} = 0$ .

§ Differential voltages are at the B input terminal with respect to the A input terminal.

¶ The algebraic convention, where the less-positive (more-negative) limit is designated as minimum, is used in this data sheet for threshold voltages only.

\* Only one output should be shorted at a time, and duration of the short-circuit should not exceed one second.

# TYPES SN55115, SN75115

## DUAL DIFFERENTIAL LINE RECEIVERS

switching characteristics,  $V_{CC} = 5\text{ V}$ ,  $C_L = 30\text{ pF}$ ,  $T_A = 25^\circ\text{ C}$

PARAMETER	TEST CONDITIONS	SN55115			SN75115			UNIT
		MIN	TYP	MAX	MIN	TYP	MAX	
$t_{PLH}$ Propagation delay time, low-to-high-level output	$R_L = 3.9\text{ k}\Omega$ , See Figure 28	18	50		18	75		ns
$t_{PHL}$ Propagation delay time, high-to-low-level output	$R_L = 390\ \Omega$ , See Figure 28	20	50		20	75		ns

### PARAMETER MEASUREMENT INFORMATION

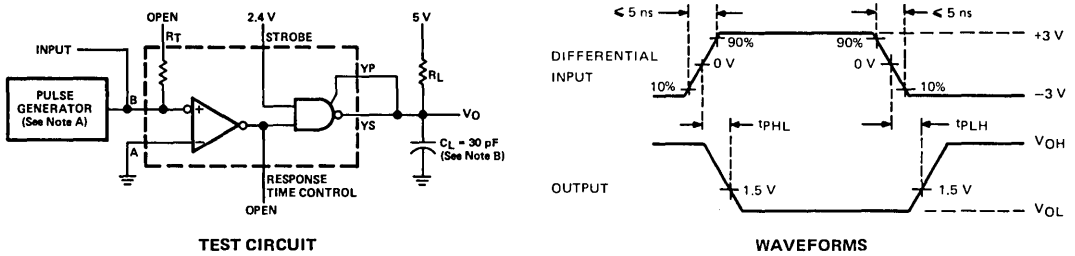

TEST CIRCUIT

WAVEFORMS

NOTES: A. The pulse generator has the following characteristics:  $Z_{out} = 50\ \Omega$ , PRR = 500 kHz,  $t_w = 100\text{ ns}$ .  
B.  $C_L$  includes probe and jig capacitance.

FIGURE 28—PROPAGATION DELAY TIMES

### TYPICAL CHARACTERISTICS†

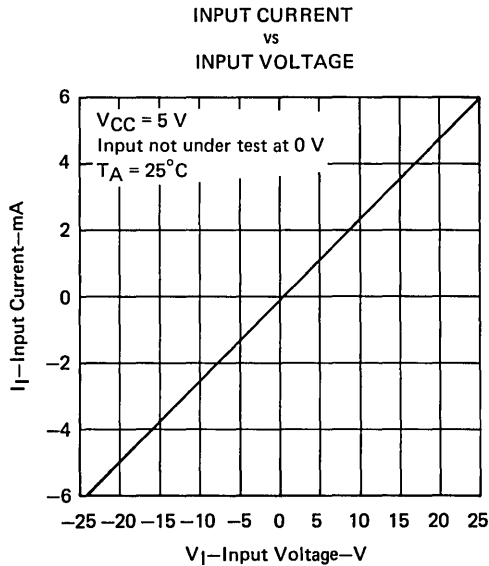

FIGURE 29

†Data for temperatures below  $0^\circ\text{ C}$  and above  $70^\circ\text{ C}$  and for supply voltages below 4.75 V and above 5.25 V are applicable to SN55115 circuits only.

# TYPES SN55115, SN75115 DUAL DIFFERENTIAL LINE RECEIVERS

## TYPICAL CHARACTERISTICS†

OUTPUT VOLTAGE  
vs  
FREE-AIR TEMPERATURE

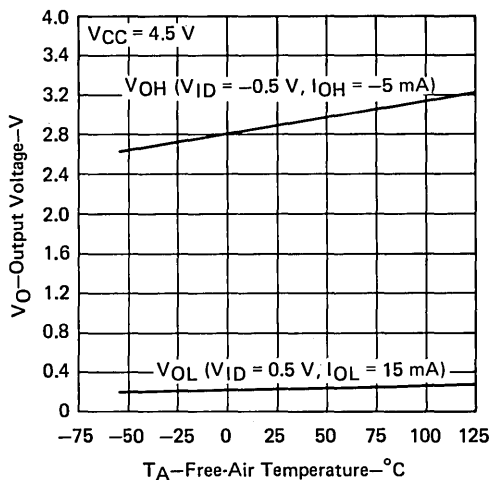

FIGURE 30

OUTPUT VOLTAGE  
vs  
COMMON-MODE INPUT VOLTAGE

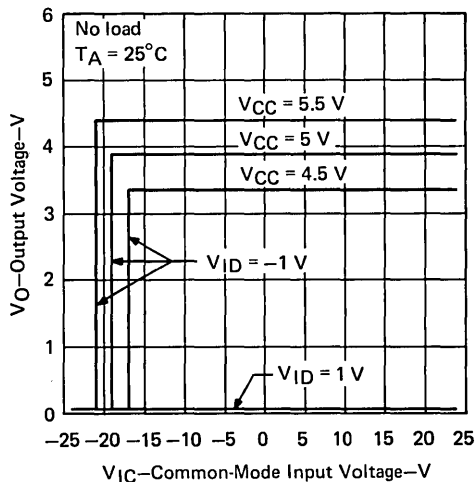

FIGURE 31

HIGH-LEVEL OUTPUT VOLTAGE  
vs  
OUTPUT CURRENT

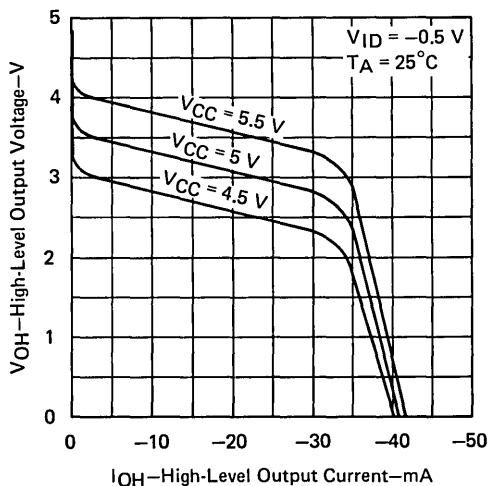

FIGURE 32

LOW-LEVEL OUTPUT VOLTAGE  
vs  
OUTPUT CURRENT

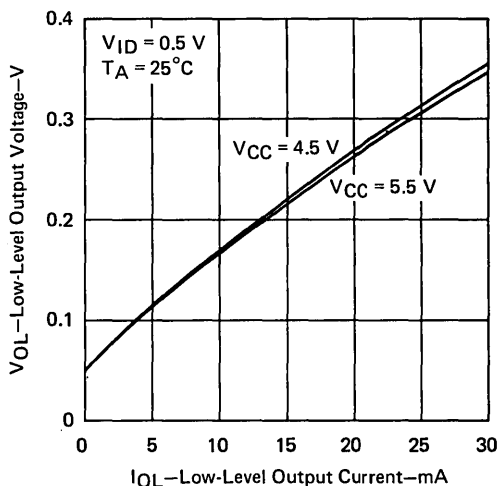

FIGURE 33

† Data for temperatures below 0°C and above 70°C and for supply voltages below 4.75 V and above 5.25 V are applicable to SN55115 circuits only. These parameters were measured with the active pull-up connected to the sink output.

# TYPES SN55115, SN75115

## DUAL DIFFERENTIAL LINE RECEIVERS

### TYPICAL CHARACTERISTICS†

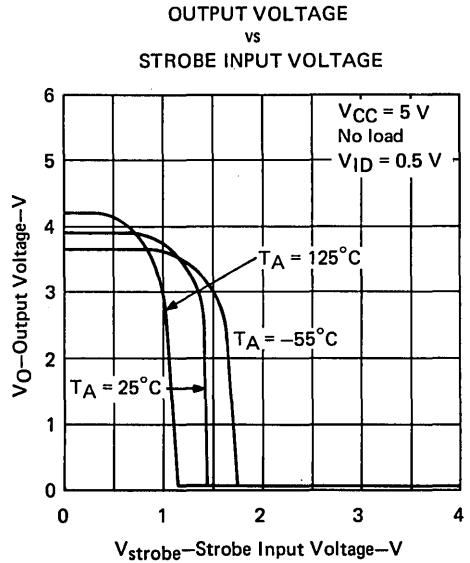
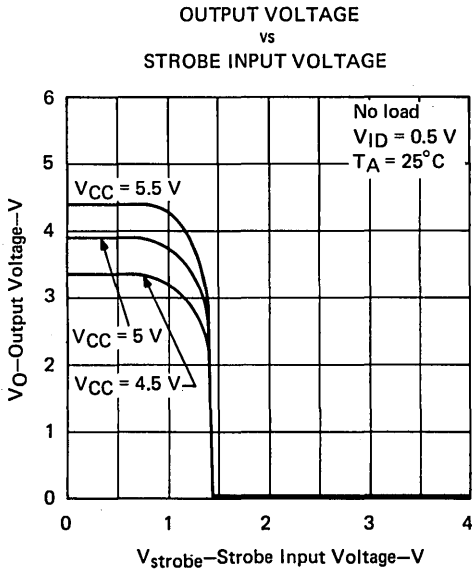
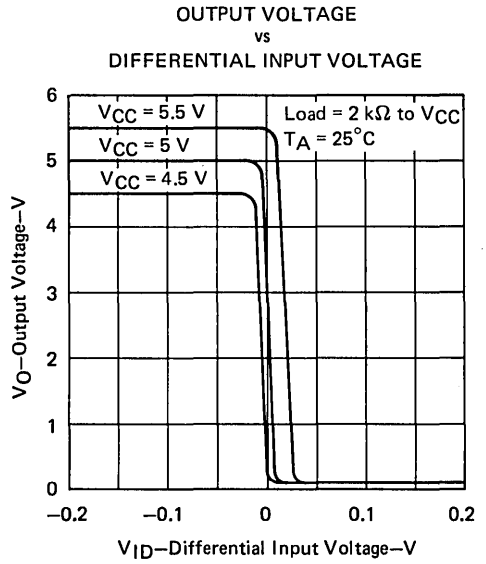
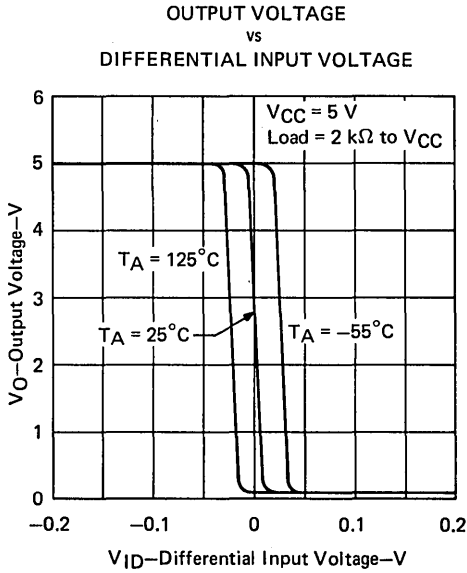

†Data for temperatures below 0°C and above 70°C and for supply voltages below 4.75 V and above 5.25 V are applicable to SN55115 circuits only. These parameters were measured with the active pull-up connected to the sink output.

# TYPES SN55115, SN75115 DUAL DIFFERENTIAL LINE RECEIVERS

## TYPICAL CHARACTERISTICS†

SUPPLY CURRENT  
(BOTH RECEIVERS)  
vs  
SUPPLY VOLTAGE

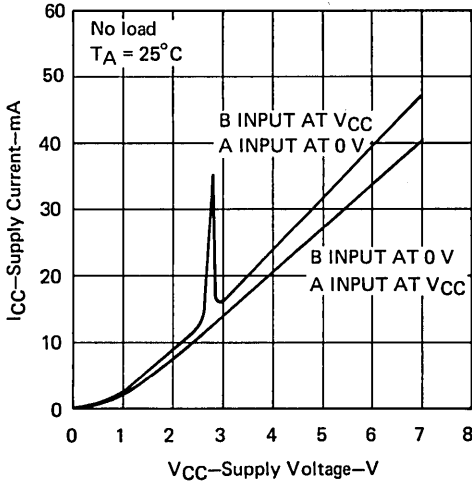

FIGURE 38

SUPPLY CURRENT  
(BOTH RECEIVERS)  
vs  
FREE-AIR TEMPERATURE

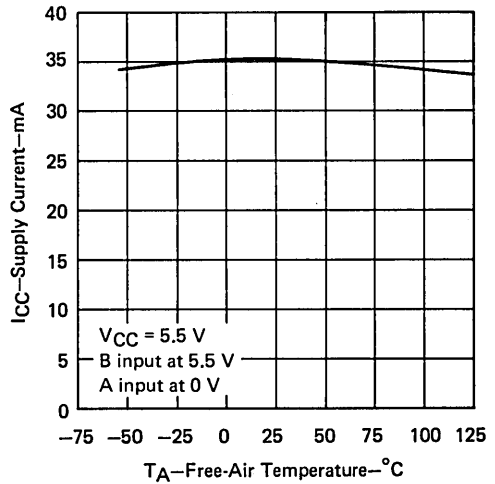

FIGURE 39

PROPAGATION DELAY TIMES  
vs  
FREE-AIR TEMPERATURE

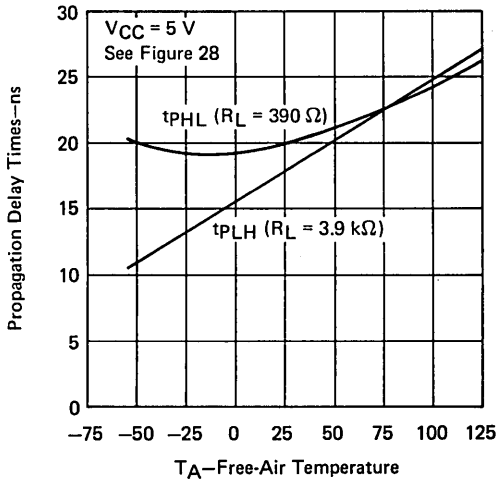

FIGURE 40

MAXIMUM OPERATING FREQUENCY  
vs  
RESPONSE-TIME-CONTROL CAPACITANCE

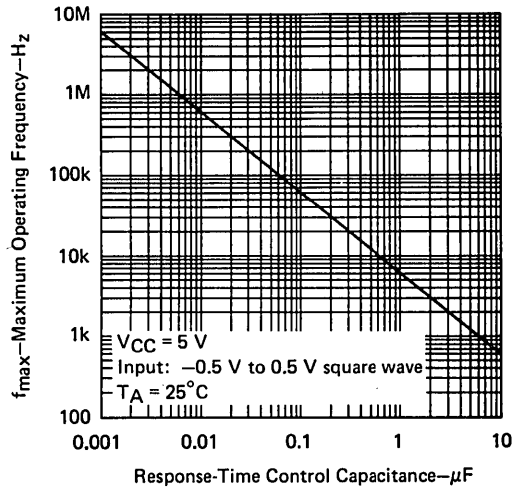

FIGURE 41

†Data for temperatures below 0°C and above 70°C and for supply voltages below 4.75 V and above 5.25 V are applicable to SN55115 circuits only. These parameters were measured with the active pull-up connected to the sink output.

**TYPES SN55113, SN55114, SN55115, SN75113, SN75114, SN75115  
DUAL DIFFERENTIAL DRIVERS AND RECEIVERS**

**TYPICAL APPLICATION DATA**

5

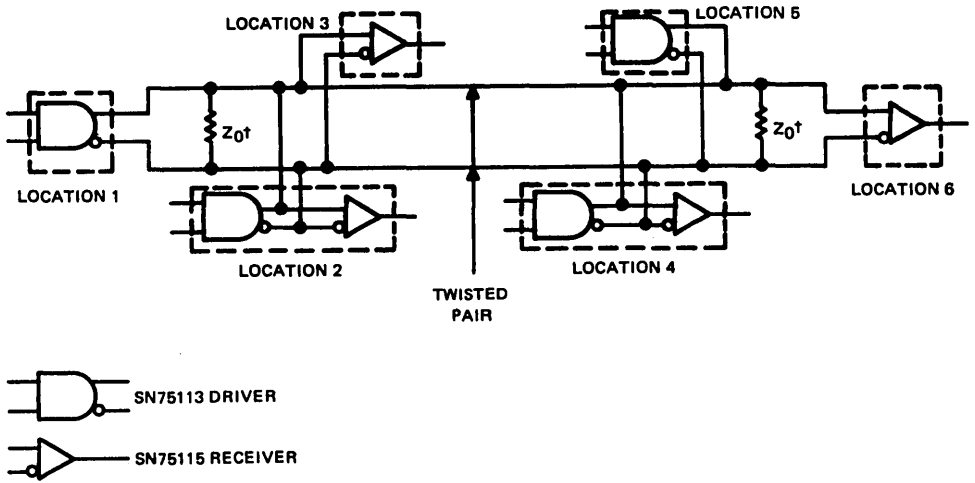

† A capacitor may be connected in series with  $Z_0$  to reduce power dissipation.

**FIGURE 42—BASIC PARTY-LINE OR DATA-BUS DIFFERENTIAL DATA TRANSMISSION**

# INTERFACE CIRCUITS

# TYPES SN55116 THRU SN55119, SN75116 THRU SN75119 DIFFERENTIAL LINE TRANSCEIVERS

BULLETIN NO. DL-S 12376, MAY 1976 — REVISED SEPTEMBER 1980

features common to all types

- Single 5-V Supply
- 3-State Driver Output Circuitry
- TTL-Compatible Driver Inputs
- TTL-Compatible Receiver Output
- Differential Line Operation
- Receiver Output Strobe ('116, '117) or Enable ('118, '119)
- Designed for Party-Line (Data-Bus) Applications
- Choice of Ceramic or Plastic Packages

additional features of the SN55116/SN55116

- Independent Driver and Receiver
- Choice of Open-Collector or Totem-Pole Outputs on Both Driver and Receiver
- Dual Data Inputs on Driver
- Optional Line-Termination Resistor in Receiver
- $\pm 15$ -V Receiver Common-Mode Capability
- Receiver Frequency Response Control

additional features of the SN55117/SN75117

- Driver Output Internally Connected to Receiver Input

The SN55118/SN75118 is an SN55116/SN75116 with 3-State Receiver Output Circuitry

The SN55119/SN75119 is an SN55117/SN75117 with 3-State Receiver Output Circuitry

## description

These integrated circuits are designed for use in interfacing between TTL-type digital systems and differential data transmission lines. They are especially useful for party-line (data-bus) applications. Each of these circuit types combine in one package a three-state differential line driver and a differential-input line receiver, both of which operate from a single 5-volt power supply. The driver inputs and receiver outputs are TTL compatible. The driver employed is similar to the SN55113/SN75113 three-state line driver, and the receiver is similar to the SN55115/SN75115 line receiver.

SN55116, SN75116  
J OR N DUAL-IN-LINE PACKAGE (TOP VIEW)

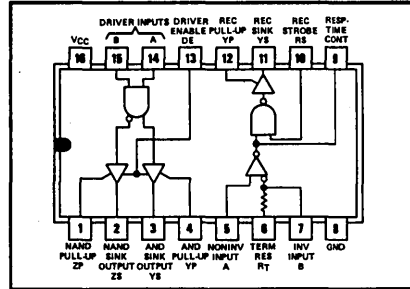

SN55117, SN75117  
JG OR P DUAL-IN-LINE PACKAGE (TOP VIEW)

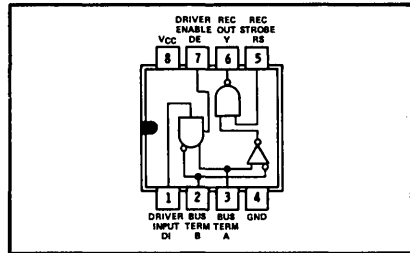

SN55118, SN75118  
J OR N DUAL-IN-LINE PACKAGE (TOP VIEW)

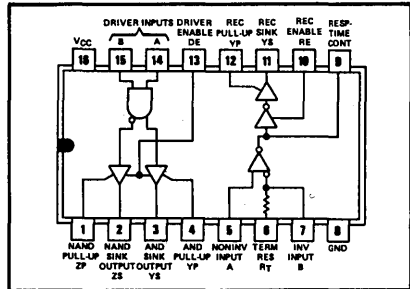

SN55119, SN75119  
JG OR P DUAL-IN-LINE PACKAGE (TOP VIEW)

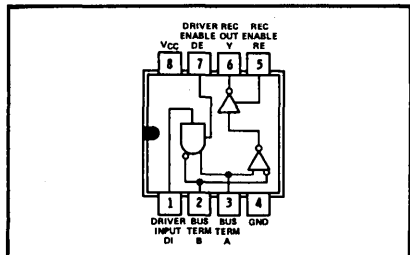

Copyright © 1980 by Texas Instruments Incorporated

TEXAS INSTRUMENTS  
INCORPORATED

POST OFFICE BOX 225012 • DALLAS, TEXAS 75265

# TYPES SN55116 THRU SN55119, SN75116 THRU SN75119

## DIFFERENTIAL LINE TRANSCEIVERS

### description (continued)

The '116 and '118 circuits offer all the features of the SN55113/SN75113 driver and the SN55115/SN75115 receiver. The driver performs the dual input AND and NAND functions when enabled, or presents a high impedance to the load when in the disabled state. The driver output stages are similar to the TTL totem-pole outputs, but have the current-sink portion separated from the current-sourcing portion and both are brought out to adjacent package pins. This feature allows the user the option of using the driver in the open-collector output configuration, or, by connecting the adjacent source and sink pins together, of using the driver in the normal totem-pole output configuration.

The receiver portion of the '116 and '118 features a differential-input circuit having a common-mode voltage range of  $\pm 15$  volts. An internal 130-ohm resistor is also provided, which may optionally be used for terminating the transmission line. A frequency response control pin allows the user to reduce the speed of the receiver or to improve differential noise immunity. The receiver of the '116 also has an output strobe and a split totem-pole output. The receiver of the '118 has an output-enable for the three-state split totem-pole output. The receiver section of either circuit is independent of the driver section except for the  $V_{CC}$  and ground pins.

The '117 and '119 circuits provide the basic driver and receiver functions of the '116 and '118, but use a package that is only half as large. The '117 and '119 are intended primarily for party-line or bus-organized systems as the driver outputs are internally connected to the receiver inputs. The driver has a single data input and a single enable input, and the '117 receiver has an output strobe while the '119 receiver has a three-state-output enable. These devices do not, however, provide output connection options, line termination resistors, or receiver frequency response controls.

The SN55116, SN55117, SN55118, and SN55119 are characterized for operation over the full military temperature range of  $-55^{\circ}\text{C}$  to  $125^{\circ}\text{C}$ ; the SN75116, SN75117, SN75118, and SN75119 are characterized for operation from  $0^{\circ}\text{C}$  to  $70^{\circ}\text{C}$ .

'116, '118  
FUNCTION TABLE  
OF DRIVER

INPUTS			OUTPUTS	
DE	A	B	Y	Z
L	X	X	Z	Z
H	L	X	L	H
H	X	L	L	H
H	H	H	H	L

'116, '118  
FUNCTION TABLE OF RECEIVER

STROBE OR ENABLE	DIFF INPUT	OUTPUT Y	
		'116	'118
L	X	H	Z
H	L	H	H
H	H	L	L

'117, '119  
FUNCTION TABLE  
OF DRIVER

INPUTS		OUTPUTS	
DI	DE	A	B
H	H	H	L
L	H	L	H
X	L	Z	Z

'117, '119  
FUNCTION TABLE OF RECEIVER

INPUTS			OUTPUT Y	
A	B	RS/RE	'117	'119
H	L	H	H	H
L	H	H	L	L
X	X	L	H	Z

H = high level ( $V_I > V_{IH}$  min or  $V_{ID}$  more positive than  $V_{TH}$  max)  
 L = low level ( $V_I < V_{IL}$  max or  $V_{ID}$  more negative than  $V_{TL}$  max)  
 X = irrelevant  
 Z = high impedance (off)  
 ? = indeterminate



# TYPES SN55116 THRU SN55119, SN75116 THRU SN75119 DIFFERENTIAL LINE TRANSCEIVERS

## schematics of inputs and outputs

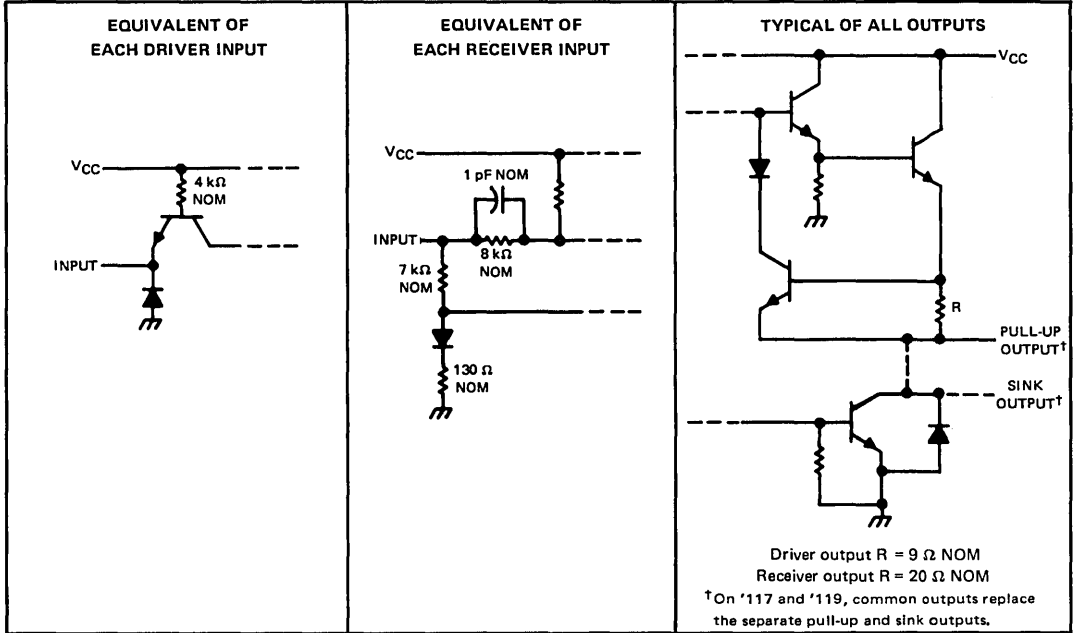

5

### absolute maximum ratings over operating free-air temperature range (unless otherwise noted)

Supply voltage, $V_{CC}$ (see Note 1)	7 V
Input voltage at data, enable, and strobe inputs	5.5 V
Input voltage at receiver and termination inputs: '116 and '118	$\pm 25$ V
Input voltage at receiver inputs: '117 and '119	0 to 6 V
Off-state voltage applied to open-collector outputs: '116 and '118	12 V
Continuous total dissipation at (or below) 25°C free-air temperature (see Note 2)	1 W
Operating free-air temperature range: SN55'	-55°C to 125°C
SN75'	0°C to 70°C
Storage temperature range	-65°C to 150°C
Lead temperature 1/16 inch from case for 60 seconds: J or JG package	300°C
Lead temperature 1/16 inch from case for 10 seconds: N or P package	260°C

- NOTES: 1. Voltage values are with respect to network ground terminal unless otherwise specified.  
 2. For operation above 25°C free-air temperature, refer to Dissipation Derating Curves in the Thermal Information section, which starts on page 2-1. In the J package, SN55116 through SN55119 chips are alloy-mounted; SN75116 through SN75119 chips are glass-mounted.

### recommended operating conditions

	SN55'			SN75'			UNIT
	MIN	NOM	MAX	MIN	NOM	MAX	
Supply voltage, $V_{CC}$	4.5	5	5.5	4.75	5	5.25	V
High-level output current, $I_{OH}$	Drivers			-40			mA
	Receivers			-5			
Low-level output current, $I_{OL}$	Drivers			40			mA
	Receivers			15			
Receiver common-mode input voltage, $V_{IC}$	'116			$\pm 15$			V
	'117			0			
Operating free-air temperature, $T_A$	-55		125	0		70	°C

# TYPES SN55116 THRU SN55119, SN75116 THRU SN75119

## DIFFERENTIAL LINE TRANSCEIVERS

electrical characteristics over recommended operating free-air temperature range (unless otherwise noted)  
driver section

PARAMETER		TEST CONDITIONS†	'116, '118			'117, '119			UNIT
			MIN	TYP‡	MAX	MIN	TYP‡	MAX	
V <sub>IH</sub>	High-level input voltage		2			2			V
V <sub>IL</sub>	Low-level input voltage		0.8			0.8			V
V <sub>IK</sub>	Input clamp voltage	V <sub>CC</sub> = MIN, I <sub>I</sub> = -12 mA	-0.9 -1.5			-0.9 -1.5			V
V <sub>OH</sub>	High-level output voltage	V <sub>CC</sub> = MIN, V <sub>IH</sub> = 2 V, V <sub>IL</sub> = 0.8 V	I <sub>OH</sub> = -10 mA	2.4	3.4	I <sub>OH</sub> = -40 mA	2.4	3.4	V
V <sub>OL</sub>	Low-level output voltage	V <sub>CC</sub> = MIN, V <sub>IH</sub> = 2 V, V <sub>IL</sub> = 0.8 V, I <sub>OL</sub> = 40 mA	0.4			0.4			V
V <sub>OK</sub>	Output clamp voltage	V <sub>CC</sub> = MAX, I <sub>O</sub> = -40 mA, DE at 0.8 V	-1.5			-1.5			V
I <sub>O(off)</sub>	Off-state open-collector output current	V <sub>CC</sub> = MAX, T <sub>A</sub> = 25°C V <sub>O</sub> = 12 V	1 10			200			μA
I <sub>OZ</sub>	Off-state (high-impedance-state) output current	V <sub>CC</sub> = MAX, V <sub>O</sub> = 0 to V <sub>CC</sub> , DE at 0.8 V, T <sub>A</sub> = 25°C	±10						μA
		V <sub>CC</sub> = MAX, V <sub>O</sub> = 0	-150						
		DE at 0.8 V, V <sub>O</sub> = 0.4 V to V <sub>CC</sub>	±80						
		T <sub>A</sub> = MAX, V <sub>O</sub> = 0 to V <sub>CC</sub>	±20						
I <sub>I</sub>	Input current at maximum input voltage	Driver or enable input	V <sub>CC</sub> = MAX, V <sub>I</sub> = 5.5 V			1			1 mA
I <sub>IH</sub>	High-level input current		V <sub>CC</sub> = MAX, V <sub>I</sub> = 2.4 V			40			40 μA
I <sub>IL</sub>	Low-level input current		V <sub>CC</sub> = MAX, V <sub>I</sub> = 0.4 V			-1.6			-1.6 mA
I <sub>OS</sub>	Short-circuit output current§	V <sub>CC</sub> = MAX, V <sub>O</sub> = 0, T <sub>A</sub> = 25°C	-40 -120			-40 -120			mA
I <sub>CC</sub>	Supply current (driver and receiver combined)	V <sub>CC</sub> = MAX	42 60			42 60			mA

† All parameters with the exception of off-state open-collector output current are measured with the active pull-up connected to the sink output. For conditions shown as MIN or MAX, use the appropriate value specified under recommended operating conditions.

‡ All typical values are at T<sub>A</sub> = 25°C and V<sub>CC</sub> = 5 V.

§ Not more than one output should be shorted at a time, and duration of the short circuit should not exceed one second.

switching characteristics, V<sub>CC</sub> = 5 V, C<sub>L</sub> = 30 pF, T<sub>A</sub> = 25°C

driver section

PARAMETER		TEST CONDITIONS	SN55'			SN75'			UNIT
			MIN	TYP	MAX	MIN	TYP	MAX	
t <sub>PLH</sub>	Propagation delay time, low-to-high-level output	See Figure 13	14 20			14 30			ns
t <sub>PHL</sub>	Propagation delay time, high-to-low-level output		12 20			12 30			
t <sub>PZH</sub>	Output enable time to high level	R <sub>L</sub> = 180 Ω, See Figure 14	8 15			8 20			ns
t <sub>PZL</sub>	Output enable time to low level	R <sub>L</sub> = 250 Ω, See Figure 15	17 30			17 40			ns
t <sub>PHZ</sub>	Output disable time from high level	R <sub>L</sub> = 180 Ω, See Figure 14	16 20			16 30			ns
t <sub>PLZ</sub>	Output disable time from low level	R <sub>L</sub> = 250 Ω, See Figure 15	20 35			20 35			ns

# TYPES SN55116 THRU SN55119, SN75116 THRU SN75119 DIFFERENTIAL LINE TRANSCEIVERS

electrical characteristics over recommended operating free-air temperature range (unless otherwise noted)  
receiver section

PARAMETER		TEST CONDITIONS†		'116, '118		'117, '119		UNIT	
				MIN	TYP‡	MAX	MIN		TYP‡
V <sub>TH</sub> ♦	Differential input high-threshold voltage¶	V <sub>O</sub> = 0.4 V, I <sub>OL</sub> = 15 mA	V <sub>IC</sub> = 0	0.5		0.5		V	
			V <sub>IC</sub> = MAX	1		1			
V <sub>TL</sub> ♦	Differential input low-threshold voltage¶	V <sub>O</sub> = 2.4 V, I <sub>OH</sub> = -5 mA	V <sub>IC</sub> = 0	-0.5#		-0.5#		V	
			V <sub>IC</sub> = MAX	-1#		-1#			
V <sub>ICR</sub>	Common-mode input voltage range¶	V <sub>CC</sub> = 5 V, V <sub>ID</sub> = -1 V or 1 V		+15 to -15	+6 to 0			V	
V <sub>IH</sub>	High-level strobe or enable input voltage			2	2			V	
V <sub>IL</sub>	Low-level strobe or enable input voltage			0.8	0.8			V	
V <sub>OH</sub>	High-level output voltage¶	V <sub>CC</sub> = MIN, I <sub>OH</sub> = -5 mA	V <sub>ID</sub> = -0.5 V, V <sub>IC</sub> = 0	2.4	2.4			V	
			V <sub>ID</sub> = -1 V, V <sub>IC</sub> = MAX	2.4	2.4				
V <sub>OL</sub>	Low-level output voltage¶	V <sub>CC</sub> = MIN, I <sub>OL</sub> = 15 mA	V <sub>ID</sub> = 0.5 V, V <sub>IC</sub> = 0	0.4		0.4		V	
			V <sub>ID</sub> = 1 V, V <sub>IC</sub> = MAX	0.4		0.4			
I <sub>I(rec)</sub>	Receiver input current¶	V <sub>CC</sub> = MAX	V <sub>I</sub> = 0 V, Other input at 0 V	-0.5	-0.9	-0.5	-1	mA	
			V <sub>I</sub> = 0.4 V, Other input at 2.4 V	-0.4	-0.7	-0.4	-0.8		
			V <sub>I</sub> = 2.4 V, Other input at 0.4 V	0.1	0.3	0.1	0.4		
I <sub>I</sub>	Input current at maximum input voltage	V <sub>CC</sub> = MIN, V <sub>strobe</sub> = 4.5 V	V <sub>ID</sub> = -0.5 V, '116, '117	5		5		µA	
			V <sub>CC</sub> = MAX, V <sub>I</sub> = 5.5 V '118, '119	1		1			
I <sub>IH</sub>	High-level input current	V <sub>CC</sub> = MAX, V <sub>I</sub> = 2.4 V		40	40			µA	
I <sub>IL</sub>	Low-level input current	V <sub>CC</sub> = MAX, V <sub>strobe</sub> = 0.4 V	V <sub>ID</sub> = 0.5 V, '116, '117	-2.4		-2.4		mA	
			V <sub>ID</sub> = 0.4 V '118, '119	-1.6		-1.6			
I <sub>(RC)</sub>	Response-time-control current (Pin 9)	V <sub>CC</sub> = MAX, V <sub>ID</sub> = 0.5 V, RC at 0 V	T <sub>A</sub> = 25°C	-1.2				mA	
I <sub>O(off)</sub>	Off-state open-collector output current	V <sub>CC</sub> = MAX, V <sub>O</sub> = 12 V, V <sub>ID</sub> = -1 V	T <sub>A</sub> = 25°C	1	10			µA	
			T <sub>A</sub> = MAX	200					
				20					
I <sub>OZ</sub>	Off-state (high-impedance state) output current	V <sub>CC</sub> = MAX, V <sub>O</sub> = 0 to V <sub>CC</sub> , RE at 0.4 V	T <sub>A</sub> = 25°C	'118, '119	±10	±10		µA	
			T <sub>A</sub> = MAX	SN55118	±40				
				SN55119			±40		
				SN75118	±20				
SN75119			±20						
R <sub>T</sub>	Line-terminating resistance	V <sub>CC</sub> = 5 V	T <sub>A</sub> = 25°C	77	167			Ω	
I <sub>OS</sub>	Short-circuit output current§	V <sub>CC</sub> = MAX, V <sub>ID</sub> = -0.5 V, V <sub>O</sub> = 0	T <sub>A</sub> = 25°C	-15	-80	-15	-80	mA	
I <sub>CC</sub>	Supply current (driver and receiver combined)	V <sub>CC</sub> = MAX, V <sub>ID</sub> = 0.5 V, V <sub>IC</sub> = 0	T <sub>A</sub> = 25°C	42	60	42	60	mA	

† Unless otherwise noted V<sub>strobe</sub> = 2.4 V. All parameters with the exception of off-state open-collector output current are measured with the active pull-up connected to the sink output. For conditions shown as MIN or MAX, use the appropriate value specified under recommended operating conditions.

‡ All typical values are at V<sub>CC</sub> = 5 V, T<sub>A</sub> = 25°C, and V<sub>IC</sub> = 0.

♦ Differential voltages are at the B input terminal with respect to the A input terminal.

¶ Measurement of these characteristics on the '117 and '119 requires the driver to be disabled with the driver enable at 0.8 V.

# The algebraic convention, where the less-positive (more-negative) limit is designated as minimum, is used in this data sheet for threshold voltages only.

§ Not more than one output should be shorted at a time.

**TEXAS INSTRUMENTS**  
INCORPORATED

POST OFFICE BOX 225012 • DALLAS, TEXAS 75265

5-91

5

# TYPES SN55116 THRU SN55119, SN75116 THRU SN75119

## DIFFERENTIAL LINE TRANSCEIVERS

switching characteristics,  $V_{CC} = 5\text{ V}$ ,  $C_L = 30\text{ pF}$ ,  $T_A = 25^\circ\text{C}$

receiver section

PARAMETER	TEST CONDITIONS	SN55'			SN75'			UNIT
		MIN	TYP	MAX	MIN	TYP	MAX	
tPLH Propagation delay time, low-to-high-level output	$R_L = 400\ \Omega$ , See Figure 16	20	50		20	75		ns
tPHL Propagation delay time, high-to-low-level output		17	50		17	75		ns
tpZH Output enable time to high level	$R_L = 480\ \Omega$ , See Figure 14	9	15		9	20		ns
tpZL Output enable time to low level	and $R_L = 250\ \Omega$ , See Figure 15	16	25		16	35		ns
tpHZ Output disable time from high level	$R_L = 480\ \Omega$ , See Figure 14	12	20		12	30		ns
tPLZ Output disable time from low level	only $R_L = 250\ \Omega$ , See Figure 15	17	25		17	35		ns

### TYPICAL CHARACTERISTICS

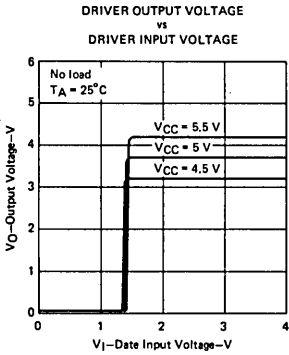

FIGURE 1

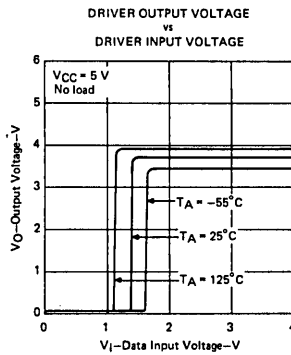

FIGURE 2

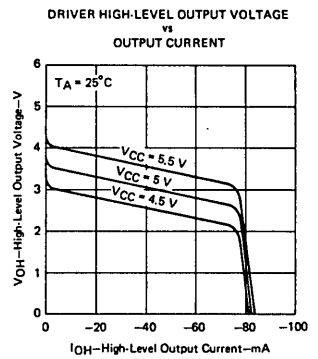

FIGURE 3

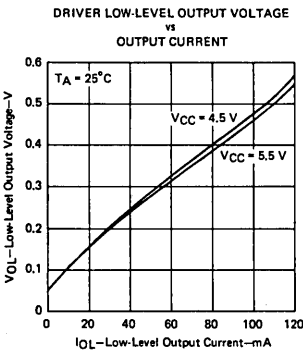

FIGURE 4

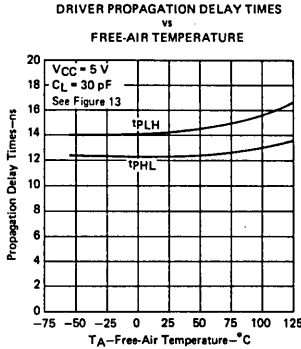

FIGURE 5

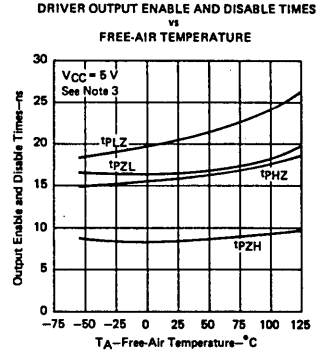

FIGURE 6

NOTE 3: For  $tp_{ZH}$  and  $tp_{HZ}$ :  $R_L = 180\ \Omega$ , see Figure 14. For  $tp_{ZL}$  and  $tp_{LZ}$ :  $R_L = 250\ \Omega$ , see Figure 15.

# TYPES SN55116 THRU SN55119, SN75116 THRU SN75119 DIFFERENTIAL LINE TRANSCEIVERS

## TYPICAL CHARACTERISTICS

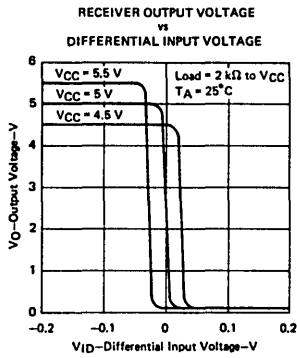

FIGURE 7

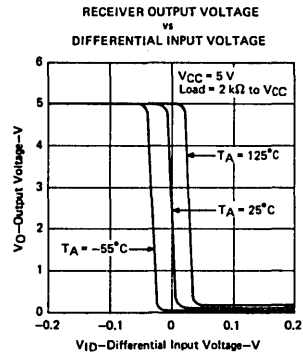

FIGURE 8

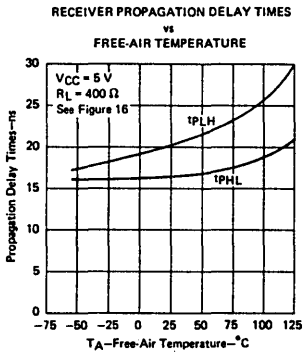

FIGURE 9

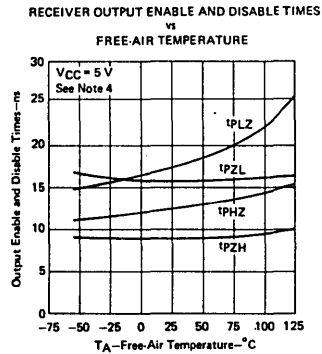

FIGURE 10

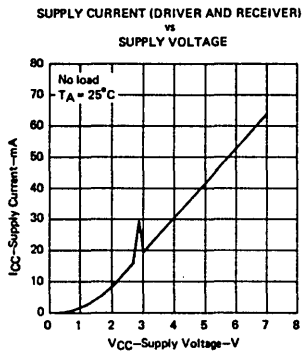

FIGURE 11

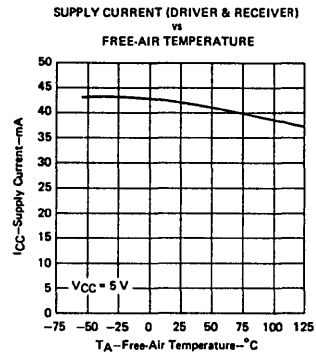

FIGURE 12

NOTE 4: For  $t_{PZH}$  and  $t_{PHZ}$ :  $R_L = 480\ \Omega$ , see Figure 14. For  $t_{PZL}$  and  $t_{PLZ}$ :  $R_L = 250\ \Omega$ , see Figure 15.

# TYPES SN55116 THRU SN55119, SN75116 THRU SN75119 DIFFERENTIAL LINE TRANSCEIVERS

## PARAMETER MEASUREMENT INFORMATION

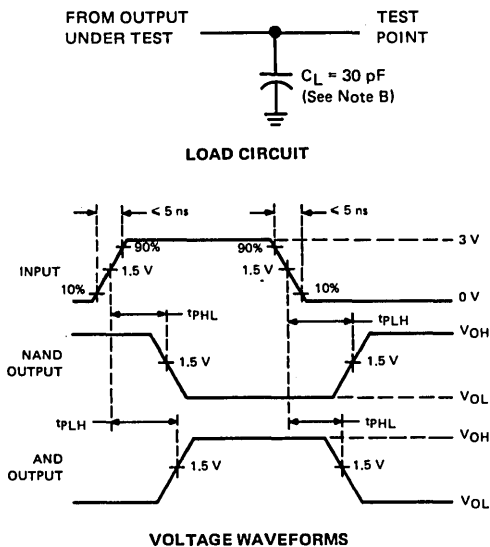

FIGURE 13— $t_{PLH}$  and  $t_{PHL}$  (DRIVERS ONLY)

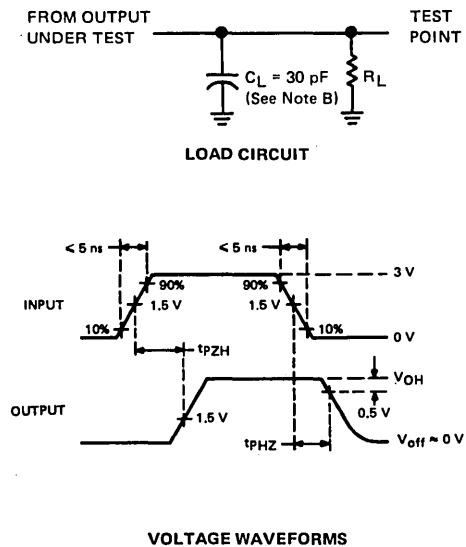

FIGURE 14— $t_{PZH}$  and  $t_{PHZ}$

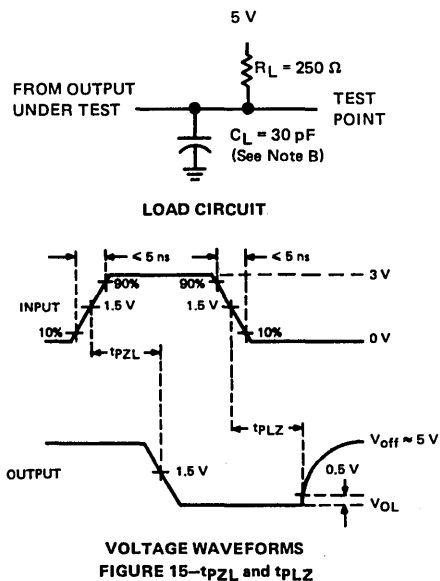

FIGURE 15— $t_{PZL}$  and  $t_{PLZ}$

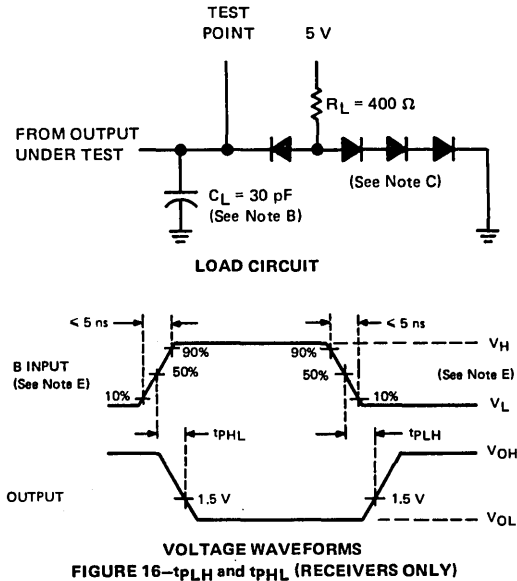

FIGURE 16— $t_{PLH}$  and  $t_{PHL}$  (RECEIVERS ONLY)

- NOTES:
- Input pulses are supplied by generators having the following characteristics:  $Z_{out} = 50 \Omega$ , PRR = 500 kHz,  $t_w = 100 \text{ ns}$ .
  - $C_L$  includes probe and jig capacitance.
  - All diodes are 1N3064 or equivalent.
  - When testing the '116 and '118 receiver sections, the response-time control and the termination resistor pins are left open.
  - For '116 and '118,  $V_H = 3 \text{ V}$ ,  $V_L = -3 \text{ V}$ , the A input is at 0 V.  
For '117 and '119,  $V_H = 3 \text{ V}$ ,  $V_L = 0 \text{ V}$ , the A input is at 1.5 V.

### LINE CIRCUITS

- Designed for Digital Data Transmission over Coaxial Cable, Strip Line, or Twisted Pair
- Designed for Operation with 50-Ω to 500-Ω Transmission Lines
- TTL Compatible with Single 5-V Supply

#### additional features of SN55121, SN75121 line drivers

- Plug-In Replacement for Signetics 8T13
- 2.4-V Output at  $I_{OH} = -75 \text{ mA}$
- Uncommitted Emitter-Follower Output Structure for Party-Line Operation
- Short-Circuit Protection
- AND-OR Logic Configuration
- High Speed . . . Maximum Propagation Delay Time = 20 ns

#### additional features of SN55122, SN75122 line receivers

- Plug-In Replacement for Signetics 8T14
- Built-In Input Threshold Hysteresis
- High Speed . . . Typical Propagation Delay Time = 20 ns
- Independent Channel Strobes
- Input Gating Increases Application Flexibility
- Fanout to 10 Series 54/74 Standard Loads

SN55121, SN75121  
J OR N  
DUAL-IN-LINE PACKAGE (TOP VIEW)

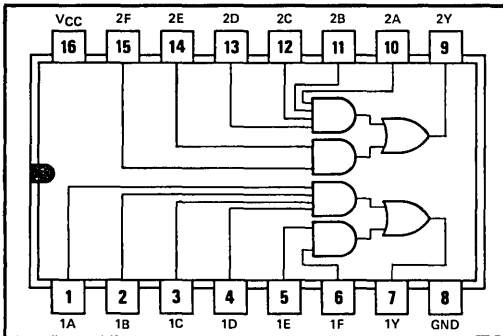

SN55122, SN75122  
J OR N  
DUAL-IN-LINE PACKAGE (TOP VIEW)

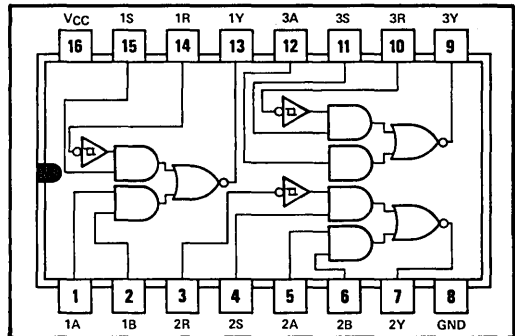

#### description

The SN55121, SN75121 dual line drivers and the SN55122, SN75122 triple line receivers are designed for digital data transmission over lines having impedances from 50 to 500 ohms. They are also compatible with standard TTL logic and supply voltage levels.

The low-impedance emitter-follower outputs of the SN55121, SN75121 will drive terminated lines such as coaxial cable or twisted pair. Having the outputs uncommitted allows wired-OR logic to be performed in party-line applications. Output short-circuit protection is provided by an internal clamping network which turns on when the output voltage drops below approximately 1.5 volts. All of the inputs are in conventional TTL configuration and the gating can be used during power-up and power-down sequences to ensure that no noise is introduced to the line.

The SN55122, SN75122 have receiver inputs with built-in hysteresis to provide increased noise margin for single-ended systems. The high impedance of this input presents a minimum load to the driver and allows termination of the transmission line in its characteristic impedance to minimize line reflection. An open line will affect the receiver input as would a low-level input voltage and the receiver input can withstand a level of  $-0.15$  volt with power on or off. The other inputs are in TTL configuration. The S input must be high to enable the receiver input. Two of the line receivers have A and B inputs which, if both are high, will hold the output low. The third receiver has only an A input which, if high, will hold the output low.

# TYPES SN55121, SN55122, SN75121, SN75122

## DUAL LINE DRIVERS AND TRIPLE LINE RECEIVERS

SN55121, SN75121 FUNCTION TABLE

INPUTS						OUTPUT
A	B	C	D	E	F	Y
H	H	H	H	X	X	H
X	X	X	X	H	H	H
All other input combinations						L

H = high level  
L = low level  
X = irrelevant

SN55122, SN75122 FUNCTION TABLE

INPUTS				OUTPUT
A	B <sup>†</sup>	R	S	Y
H	H	X	X	L
X	X	L	H	L
L	X	H	X	H
L	X	X	L	H
X	L	H	X	H
X	L	X	L	H

<sup>†</sup>B input and last two lines of the function table are applicable to receivers 1 and 2 only.

SN55121, SN75121 schematic (each driver)

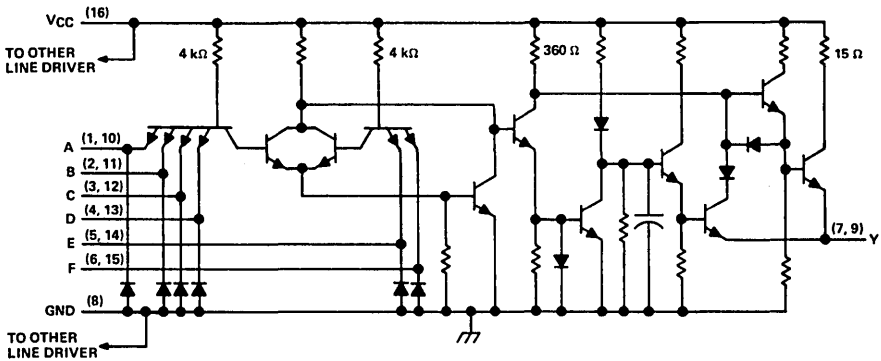

SN55122, SN75122 schematic (each receiver)

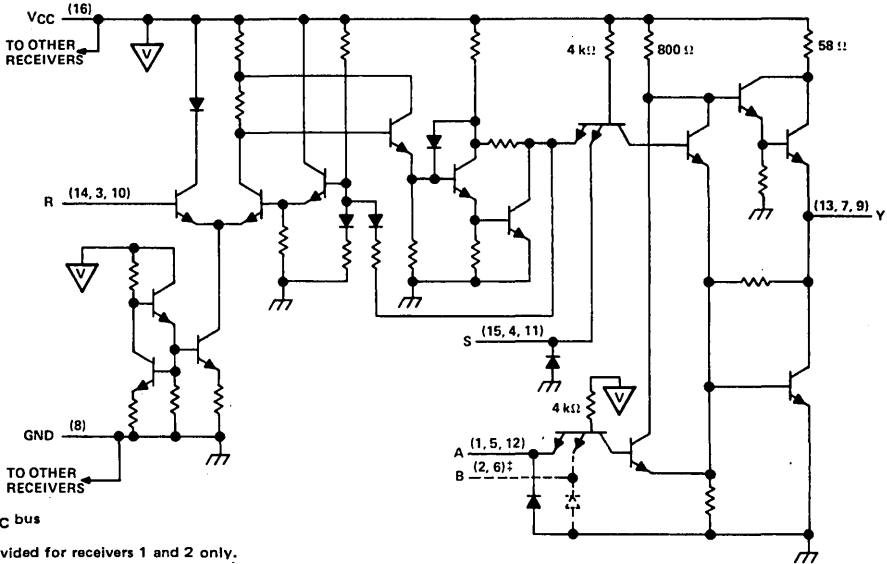

<sup>†</sup>B input is provided for receivers 1 and 2 only.  
Resistor values shown are nominal.



# TYPES SN55121, SN75121 DUAL LINE DRIVERS

## SN55121, SN75121 absolute maximum ratings over operating free-air temperature range (unless otherwise noted)

Supply voltage, $V_{CC}$ (see Note 1)	6 V
Input voltage	6 V
Output voltage	6 V
Continuous total dissipation at (or below) 25°C free-air temperature (see Note 2)	1 W
Operating free-air temperature range: SN55121	-55°C to 125°C
SN75121	0°C to 75°C
Lead temperature 1/16 inch from case for 60 seconds: J package	300°C
Lead temperature 1/16 inch from case for 10 seconds: N package	260°C

## SN55121, SN75121 recommended operating conditions

	MIN	NOM	MAX	UNIT
Supply voltage, $V_{CC}$	4.75	5	5.25	V
High-level output current, $I_{OH}$			-75	mA
Operating free-air temperature, $T_A$ : SN55121	-55		125	°C
SN75121	0		75	°C

## SN55121, SN75121 electrical characteristics over recommended operating free-air temperature range, $V_{CC} = 4.75$ V to 5.25 V (unless otherwise noted)

PARAMETER	TEST CONDITIONS	MIN	MAX	UNIT
$V_{IH}$ High-level input voltage		2		V
$V_{IL}$ Low-level input voltage			0.8	V
$V_{IK}$ Input clamp voltage	$V_{CC} = 5$ V, $I_I = -12$ mA		-1.5	V
$V_{(BR)I}$ Input breakdown voltage	$V_{CC} = 5$ V, $I_I = 10$ mA	5.5		V
$V_{OH}$ High-level output voltage	$V_{IH} = 2$ V, $I_{OH} = -75$ mA, See Note 3	2.4		V
$I_{OH}$ High-level output current	$V_{CC} = 5$ V, $V_{IH} = 4.5$ V, $V_{OH} = 2$ V, $T_A = 25^\circ$ C, See Note 3	-100	-250	mA
$I_{OL}$ Low-level output current	$V_{IL} = 0.8$ V, $V_{OL} = 0.4$ V, See Note 3		-800	$\mu$ A
$I_{O(off)}$ Off-state output current	$V_{CC} = 3$ V, $V_O = 3$ V		500	$\mu$ A
$I_{IH}$ High-level input current	$V_I = 4.5$ V		40	$\mu$ A
$I_{IL}$ Low-level input current	$V_I = 0.4$ V	-0.1	-1.6	mA
$I_{OS}$ Short-circuit output current <sup>†</sup>	$V_{CC} = 5$ V, $T_A = 25^\circ$ C		-30	mA
$I_{CCH}$ Supply current, outputs high	$V_{CC} = 5.25$ V, All inputs at 2 V, Outputs open		28	mA
$I_{CCL}$ Supply current, outputs low	$V_{CC} = 5.25$ V, All inputs at 0.8 V, Outputs open		60	mA

<sup>†</sup>Not more than one output should be shorted at a time.

## SN55121, SN75121 switching characteristics, $V_{CC} = 5$ V, $T_A = 25^\circ$ C

PARAMETER	TEST CONDITIONS	MIN	TYP	MAX	UNIT
$t_{PLH}$ Propagation delay time, low-to-high-level output	$R_L = 37 \Omega$ , $C_L = 15$ pF,		11	20	ns
$t_{PHL}$ Propagation delay time, high-to-low-level output	See Figure 1		8	20	
$t_{PLH}$ Propagation delay time, low-to-high-level output	$R_L = 37 \Omega$ , $C_L = 1000$ pF,		22	50	ns
$t_{PHL}$ Propagation delay time, high-to-low-level output	See Figure 1		20	50	

NOTES: 1. Voltage values are with respect to network ground terminal.

2. For operation above 25°C free-air temperature, refer to the Dissipation Derating Curves in the Thermal Information section, which starts on page 2-1. In the J package, SN55121 chips are alloy-mounted; SN75121 chips are glass-mounted.

3. The output voltage and current limits are guaranteed for any appropriate combination of high and low inputs specified by the function table for the desired output.

# TYPES SN55122, SN75122

## TRIPLE LINE RECEIVERS

### SN55122, SN75122 absolute maximum ratings over operating free-air temperature range (unless otherwise noted)

Supply voltage, $V_{CC}$ (see Note 1)	6 V
Input voltage: R input	6 V
A, B, or S input	5.5 V
Output voltage	6 V
Output current	$\pm 100$ mA
Continuous total dissipation at (or below) 25°C free-air temperature (see Note 6)	1 W
Operating free-air temperature range: SN55122	-55°C to 125°C
SN75122	0°C to 75°C
Storage temperature range	-65°C to 150°C
Lead temperature 1/16 inch from case for 60 seconds: J package	300°C
Lead temperature 1/16 inch from case for 10 seconds: N package	260°C

### SN55122, SN75122 recommended operating conditions

	MIN	NOM	MAX	UNIT
Supply voltage, $V_{CC}$	4.75	5	5.25	V
High-level output current, $I_{OH}$			-500	$\mu$ A
Low-level output current, $I_{OL}$			16	mA
Operating free-air temperature, $T_A$ : SN55122	-55		125	°C
SN75122	0		75	°C

### SN55122, SN75122 electrical characteristics over recommended operating free-air temperature range, $V_{CC} = 4.75$ V to 5.25 V (unless otherwise noted)

PARAMETER		TEST CONDITIONS	MIN	TYP	MAX	UNIT
$V_{IH}$	High-level input voltage	A, B, R, or S	2			V
$V_{IL}$	Low-level input voltage	A, B, R, or S			0.8	V
$V_{T+} - V_{T-}$	Hysteresis <sup>†</sup>	R	$V_{CC} = 5$ V,	$T_A = 25^\circ$ C	0.3 0.6	V
$V_{IK}$	Input clamp voltage	A, B, or S	$V_{CC} = 5$ V,	$I_I = -12$ mA	-1.5	V
$V_{(BR)}$	Input breakdown voltage	A, B, or S	$V_{CC} = 5$ V,	$I_I = 10$ mA	5.5	V
$V_{OH}$	High-level output voltage	$V_{IH} = 0$ V,	$V_{IL} = 0.8$ V,	$I_{OH} = -500$ $\mu$ A,	2.6	V
		See Note 3				
$V_{OL}$	Low-level output voltage	$V_{IH(A)} = 0$ V,	$V_{IH(B)} = 0$ V,	$V_{IH(S)} = 2$ V,	2.6	V
		$V_{IH(R)} = 1.45$ V (See Note 4),	$I_{OH} = -500$ $\mu$ A			
$V_{OL}$	Low-level output voltage	$V_{IH} = 2$ V,	$V_{IL} = 0.8$ V,	$I_{OL} = 16$ mA,	0.4	V
		See Note 3				
$I_{IH}$	High-level input current	A, B, or S	$V_I = 4.5$ V		40	$\mu$ A
		R	$V_I = 3.8$ V		170	
$I_{IL}$	Low-level input current	A, B, or S	$V_I = 0.4$ V		-0.1 -1.6	mA
$I_{OS}$	Short-circuit output current <sup>‡</sup>		$V_{CC} = 5$ V,	$T_A = 25^\circ$ C	-50 -100	mA
$I_{CC}$	Supply current		$V_{CC} = 5.25$ V		72	mA

<sup>†</sup>Hysteresis is the difference between the positive-going input threshold voltage,  $V_{T+}$ , and the negative-going input threshold voltage,  $V_{T-}$ . See Figure 4.

<sup>‡</sup>Not more than one output should be shorted at a time and duration of the short-circuit should not exceed one second.

NOTES: 1. Voltage values are with respect to network ground terminal.

3. The output voltage limits are guaranteed for any appropriate combination of high and low inputs specified by the function table for the desired output.

4. Receiver input was at a high level immediately before being reduced to 1.45 V.

5. Receiver input was at a low level immediately before being raised to 1.45 V.

6. For operation above 25°C free-air temperature, refer to the Dissipation Derating Curves in the Thermal Information section, which starts on page 2-1. In the J package, SN55122 chips are alloy-mounted; SN75122 chips are glass-mounted.

# TYPES SN55121, SN55122, SN75121, SN75122 DUAL LINE DRIVERS AND TRIPLE LINE RECEIVERS

SN55122, SN75122 switching characteristics,  $V_{CC} = 5\text{ V}$ ,  $T_A = 25^\circ\text{C}$

PARAMETER	TEST CONDITIONS	MIN	TYP	MAX	UNIT
$t_{PLH}$ Propagation delay time, low-to-high-level output from R input	See Figure 2		20	30	ns
$t_{PHL}$ Propagation delay time, high-to-low-level output from R input			20	30	

### PARAMETER MEASUREMENT INFORMATION

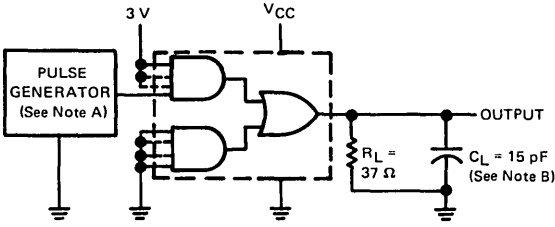

TEST CIRCUIT

FIGURE 1—SN55121, SN75121 SWITCHING TIMES

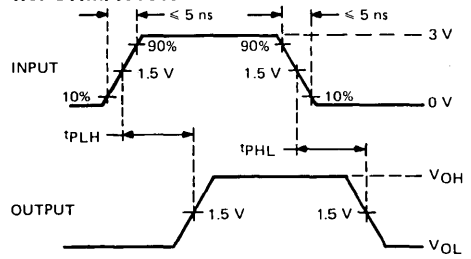

VOLTAGE WAVEFORMS

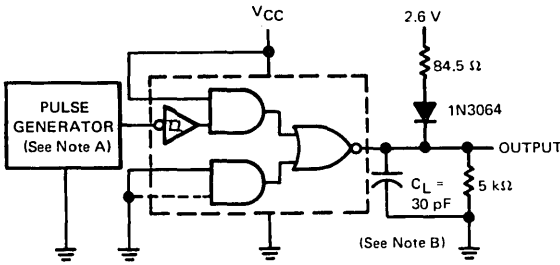

TEST CIRCUIT

FIGURE 2—SN55122, SN75122 SWITCHING TIMES

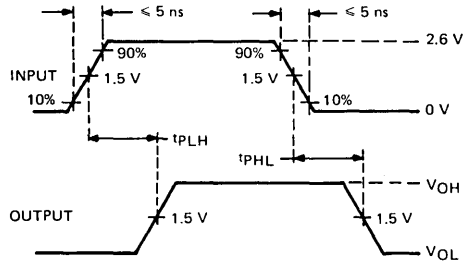

VOLTAGE WAVEFORMS

NOTES: A. The pulse generators have the following characteristics:  $Z_{out} \approx 50\ \Omega$ ,  $t_w = 200\text{ ns}$ , duty cycle = 50%.  
B.  $C_L$  includes probe and jig capacitance.

### TYPICAL CHARACTERISTICS

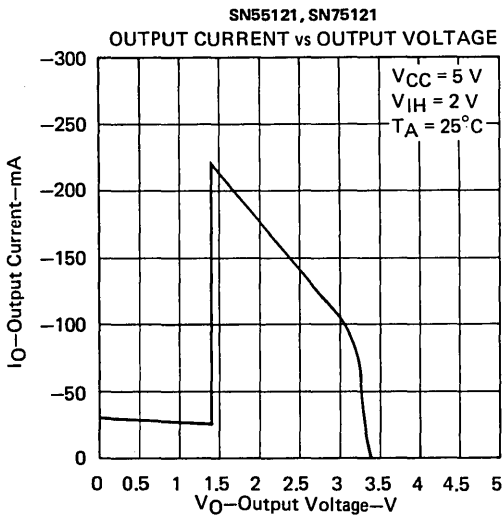

FIGURE 3

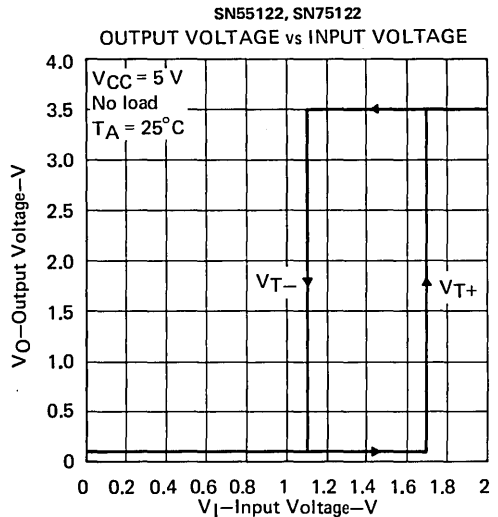

FIGURE 4

**TEXAS INSTRUMENTS**  
INCORPORATED

POST OFFICE BOX 225012 • DALLAS, TEXAS 75265

# TYPES SN55121, SN55122, SN75121, SN75122

## DUAL LINE DRIVERS AND TRIPLE LINE RECEIVERS

### TYPICAL APPLICATION DATA

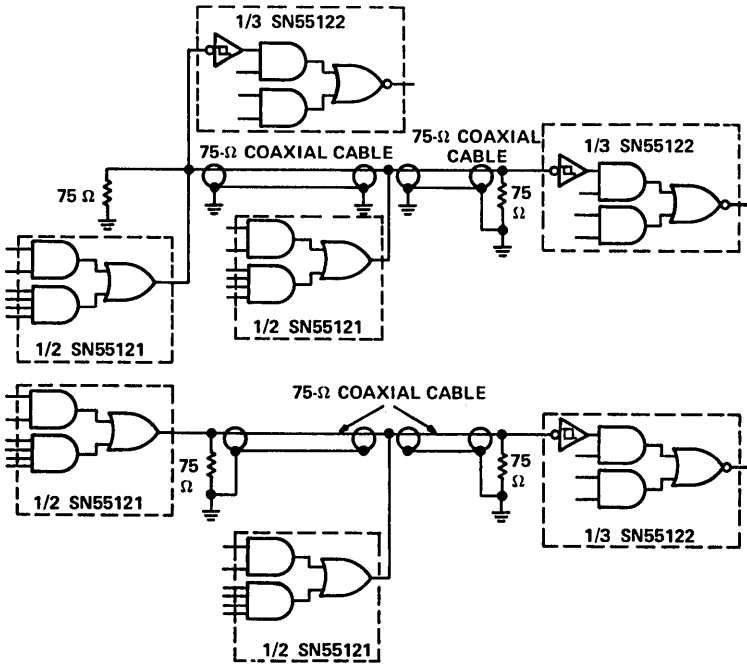
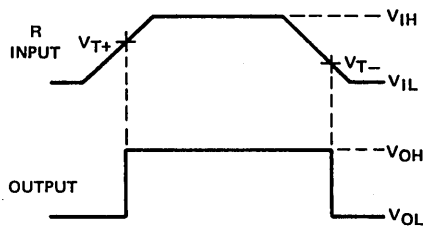

FIGURE 5—SINGLE-ENDED PARTY LINE CIRCUITS



The high gain and built-in hysteresis of the SN55122 and SN75122 line receivers enable them to be used as Schmitt triggers in squaring up pulses.

FIGURE 6—PULSE SQUARING

**LINE CIRCUITS**

- Meet IBM System 360 Input/Output Interface Specifications
- Operate from Single 5-V Supply
- TTL Compatible

**additional features of SN75123 line driver**

- Plug-In Replacement for Signetics 8T23
- 3.11-V Output at  $I_{OH} = -59.3 \text{ mA}$
- Uncommitted Emitter-Follower Output Structure for Party-Line Operation
- Short-Circuit Protection
- AND-OR Logic Configuration

**additional features of SN75124 line receiver**

- Plug-In Replacement for Signetics 8T24
- Built-In Input Threshold Hysteresis
- High Speed . . . Typical Propagation Delay Time = 20 ns
- Independent Channel Strobes
- Input Gating Increases Application Flexibility

SN75123  
J OR N  
DUAL-IN-LINE PACKAGE (TOP VIEW)

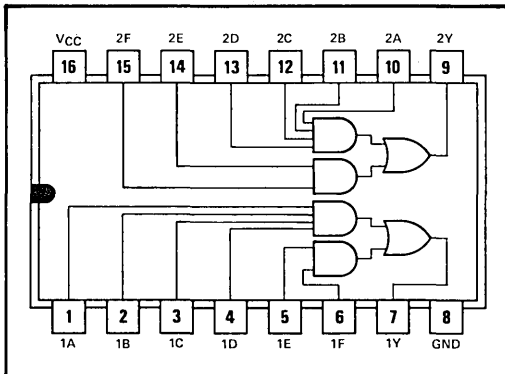

SN75124  
J OR N  
DUAL-IN-LINE PACKAGE (TOP VIEW)

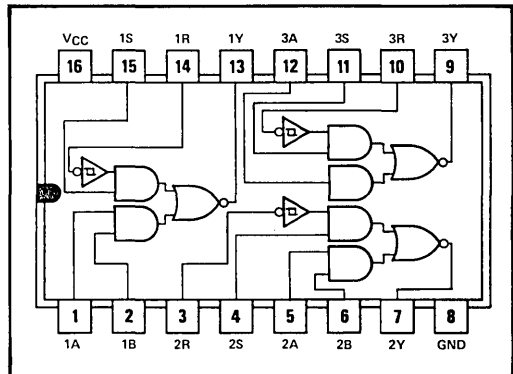

**description**

The SN75123 dual line driver and the SN75124 triple line receiver are both specifically designed to meet the input/output interface specifications for IBM System 360. They are also compatible with standard TTL logic and supply voltage levels.

The low-impedance emitter-follower outputs of the SN75123 will drive terminated lines such as coaxial cable or twisted pair. Having the outputs uncommitted allows wired-OR logic to be performed in party-line applications. Output short-circuit protection is provided by an internal clamping network which turns on when the output voltage drops below approximately 1.5 volts. All of the inputs are in conventional TTL configuration and the gating can be used during power-up and power-down sequences to ensure that no noise is introduced to the line.

The SN75124 has receiver inputs with built-in hysteresis to provide increased noise margin for single-ended systems. An open line will affect the receiver input as would a low-level input voltage and the receiver input can withstand a level of  $-0.15$  volt with power on or off. The other inputs are in TTL configuration. The S input must be high to enable the receiver input. Two of the line receivers have A and B inputs which, if both are high, will hold the output low. The third receiver has only an A input which, if high, will hold the output low.

# TYPES SN75123, SN75124

## DUAL LINE DRIVER AND TRIPLE LINE RECEIVER

SN75123 FUNCTION TABLE

INPUTS						OUTPUT
A	B	C	D	E	F	Y
H	H	H	H	X	X	H
X	X	X	X	H	H	H
All other input combinations						L

H = high level  
L = low level  
X = irrelevant

SN75124 FUNCTION TABLE

INPUTS				OUTPUT
A	B†	R	S	Y
H	H	X	X	L
X	X	L	H	L
L	X	H	X	H
L	X	X	L	H
X	L	H	X	H
X	L	X	L	H

†B input and last two lines of the function table are applicable to receivers 1 and 2 only.

SN75123 schematic (each driver)

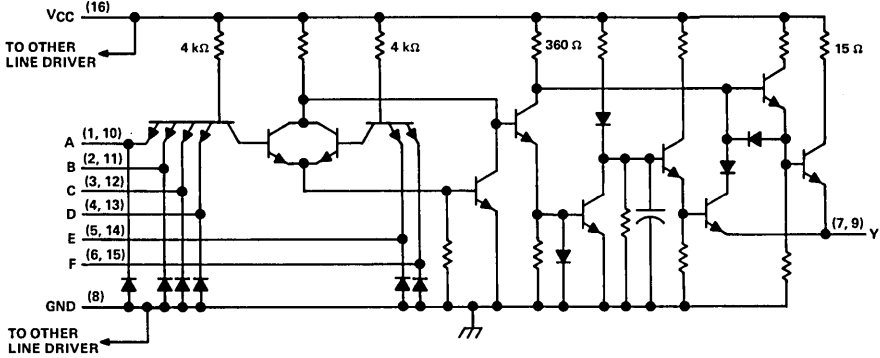

SN75124 schematic (each receiver)

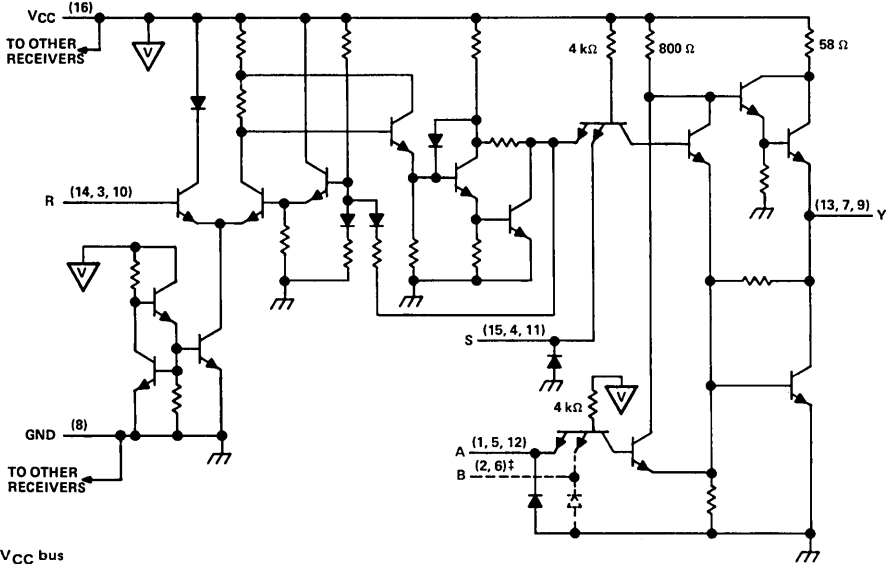

▽ . . . V<sub>CC</sub> bus

†B input is provided on receivers 1 and 2 only  
Resistor values shown are nominal

5

# SN75123 DUAL LINE DRIVER

## SN75123 absolute maximum ratings over operating free-air temperature range (unless otherwise noted)

Supply voltage, $V_{CC}$ (see Note 1)	7 V
Input voltage	5.5 V
Output voltage	7 V
Continuous total dissipation at (or below) 25°C free-air temperature (see Note 2)	1 W
Operating free-air temperature range	0°C to 75°C
Storage temperature range	-65°C to 150°C
Lead temperature 1/16 inch from case for 60 seconds: J package	300°C
Lead temperature 1/16 inch from case for 10 seconds: N package	260°C

## SN75123 recommended operating conditions

	MIN	NOM	MAX	UNIT
Supply voltage, $V_{CC}$	4.75	5	5.25	V
High-level output current, $I_{OH}$			-100	mA
Operating free-air temperature, $T_A$	0		75	°C

## SN75123 electrical characteristics, $V_{CC} = 4.75\text{ V to }5.25\text{ V}$ , $T_A = 0^\circ\text{C to }75^\circ\text{C}$ (unless otherwise noted)

PARAMETER		TEST CONDITIONS		MIN	TYP	MAX	UNIT	
$V_{IH}$	High-level input voltage			2			V	
$V_{IL}$	Low-level input voltage					0.8	V	
$V_{IK}$	Input clamp voltage	$V_{CC} = 5\text{ V}$ ,	$I_I = -12\text{ mA}$			-1.5	V	
$V_{(BR)I}$	Input breakdown voltage	$V_{CC} = 5\text{ V}$ ,	$I_I = 10\text{ mA}$	5.5			V	
$V_{OH}$	High-level output voltage	$V_{CC} = 5\text{ V}$ ,	$V_{IH} = 2\text{ V}$ ,	$T_A = 25^\circ\text{C}$	3.11		V	
				$T_A = 0^\circ\text{C to }75^\circ\text{C}$	2.9			
$I_{OH}$	High-level output current	$V_{CC} = 5\text{ V}$ ,	$V_{IH} = 4.5\text{ V}$ ,	$V_{OH} = 2\text{ V}$ ,			mA	
		$T_A = 25^\circ\text{C}$ ,	See Note 3			-100	-250	
$V_{OL}$	Low-level output voltage	$V_{IL} = 0.8\text{ V}$ ,	$I_{OL} = -240\text{ }\mu\text{A}$ ,	See Note 3			0.15	V
$I_{O(off)}$	Off-state output current	$V_{CC} = 0$ ,	$V_O = 3\text{ V}$				40	$\mu\text{A}$
$I_{IH}$	High-level input current	$V_I = 4.5\text{ V}$					40	$\mu\text{A}$
$I_{IL}$	Low-level input current	$V_I = 0.4\text{ V}$		-0.1		-1.6	mA	
$I_{OS}$	Short-circuit output current ‡	$V_{CC} = 5\text{ V}$ ,	$T_A = 25^\circ\text{C}$				-30	mA
$I_{CCH}$	Supply current, outputs high	$V_{CC} = 5.25\text{ V}$ ,	All inputs at 2 V,				28	mA
		Outputs open						
$I_{CCL}$	Supply current, outputs low	$V_{CC} = 5.25\text{ V}$ ,	All inputs at 0.8 V,				60	mA
		Outputs open						

‡ Not more than one output should be shorted at a time.

## SN75123 switching characteristics, $V_{CC} = 5\text{ V}$ , $T_A = 25^\circ\text{C}$

PARAMETER		TEST CONDITIONS		MIN	TYP	MAX	UNIT
$t_{PLH}$	Propagation delay time, low-to-high-level output	$R_L = 50\text{ }\Omega$ ,	$C_L = 15\text{ pF}$ ,		12	20	ns
$t_{PHL}$	Propagation delay time, high-to-low-level output					12	
$t_{PLH}$	Propagation delay time, low-to-high-level output	$R_L = 50\text{ }\Omega$ ,	$C_L = 100\text{ pF}$ ,		20	35	ns
$t_{PHL}$	Propagation delay time, high-to-low-level output					15	

- NOTES: 1. Voltage values are with respect to network ground terminal.  
 2. For operation above 25°C free-air temperature, refer to the Dissipation Derating Curves in the Thermal Information section, which starts on page 2-1. In the J package, SN75123 chips are glass-mounted.  
 3. The output voltage and current limits are guaranteed for any appropriate combination of high and low inputs specified by the function table for the desired output.

# TYPE SN75124

## TRIPLE LINE RECEIVER

### SN75124 absolute maximum ratings over operating free-air temperature range (unless otherwise noted)

Supply voltage, $V_{CC}$ (see Note 1)	7 V
Input voltage: R input with $V_{CC}$ applied	7 V
R input with $V_{CC}$ not applied	6 V
A, B, or S input	5.5 V
Output voltage	7 V
Output current	$\pm 100$ mA
Continuous total dissipation at (or below) 25°C free-air temperature (see Note 4)	1 W
Operating free-air temperature range	0°C to 75°C
Storage temperature range	-65°C to 150°C
Lead temperature 1/16 inch from case for 60 seconds: J package	300°C
Lead temperature 1/16 inch from case for 10 seconds: N package	260°C

### SN75124 recommended operating conditions

	MIN	NOM	MAX	UNIT
Supply voltage, $V_{CC}$	4.75	5	5.25	V
High-level output current, $I_{OH}$			-800	$\mu$ A
Low-level output current, $I_{OL}$			16	mA
Operating free-air temperature, $T_A$	0		75	°C

### SN75124 electrical characteristics, $V_{CC} = 4.75$ V to 5.25 V, $T_A = 0^\circ$ C to 75°C (unless otherwise noted)

PARAMETER		TEST CONDITIONS		MIN	TYP	MAX	UNIT
$V_{IH}$	High-level input voltage	A, B, or S		2			V
		R		1.7			
$V_{IL}$	Low-level input voltage	A, B, or S				0.8	V
		R				0.7	
$V_{T+}-V_{T-}$	Hysteresis†	R	$V_{CC} = 5$ V, $T_A = 25^\circ$ C	0.2	0.4		V
$V_{IK}$	Input clamp voltage	A, B, or S	$V_{CC} = 5$ V, $I_I = -12$ mA			-1.5	V
$V_{(BR)I}$	Input breakdown voltage	A, B, or S	$V_{CC} = 5$ V, $I_I = 10$ mA	5.5			V
$V_{OH}$	High-level output voltage		$V_{IH} = V_{IH\ min}$ , $V_{IL} = V_{IL\ max}$ , $I_{OH} = -800$ $\mu$ A, See Note 3	2.6			V
$V_{OL}$	Low-level output voltage		$V_{IH} = V_{IH\ min}$ , $V_{IL} = V_{IL\ max}$ , $I_{OL} = 16$ mA, See Note 3			0.4	V
$I_I$	Input current at maximum input voltage	R	$V_I = 7$ V			5	mA
			$V_I = 6$ V, $V_{CC} = 0$			5	
$I_{IH}$	High-level input current	A, B, or S	$V_I = 4.5$ V			40	$\mu$ A
		R	$V_I = 3.11$ V			170	
$I_{IL}$	Low-level input current	A, B, or S	$V_I = 0.4$ V	-0.1		-1.6	mA
$I_{OS}$	Short-circuit output current‡		$V_{CC} = 5$ V, $T_A = 25^\circ$ C	-50		-100	mA
$I_{CC}$	Supply current		$V_{CC} = 5.25$ V			72	mA

† Hysteresis is the difference between the positive-going input threshold voltage,  $V_{T+}$ , and the negative-going input threshold voltage,  $V_{T-}$ . See Figure 4.

‡ Not more than one output should be shorted at a time, and duration of the short-circuit should not exceed one second.

### SN75124 switching characteristics, $V_{CC} = 5$ V, $T_A = 25^\circ$ C

PARAMETER	TEST CONDITIONS	MIN	TYP	MAX	UNIT
$t_{PLH}$ Propagation delay time, low-to-high-level output from R input	See Figure 2		20	30	ns
$t_{PHL}$ Propagation delay time, high-to-low-level output from R input			20	30	

- NOTES: 1. Voltage values are with respect to network ground terminal.  
 3. The output voltage and current limits are guaranteed for any appropriate combination of high and low inputs specified by the function table for the desired output.  
 4. For operation above 25°C free-air temperature, refer to the Dissipation Derating Curves in the Thermal Information section, which starts on page 2-1. In the J package, SN75124 chips are glass-mounted.



# TYPES SN75123, SN75124 DUAL LINE DRIVER AND TRIPLE LINE RECEIVER

## PARAMETER MEASUREMENT INFORMATION

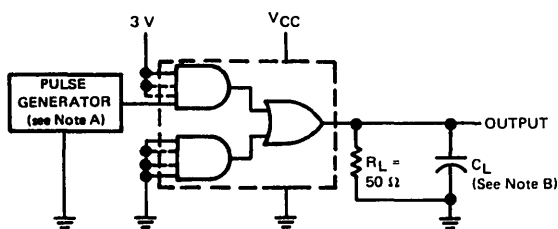

TEST CIRCUIT

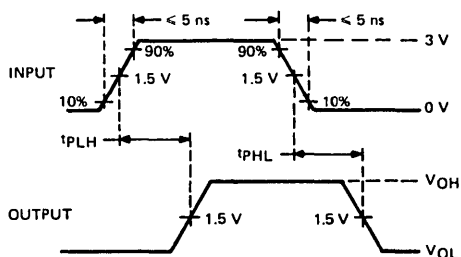

VOLTAGE WAVEFORMS

FIGURE 1—SN75123 SWITCHING TIMES

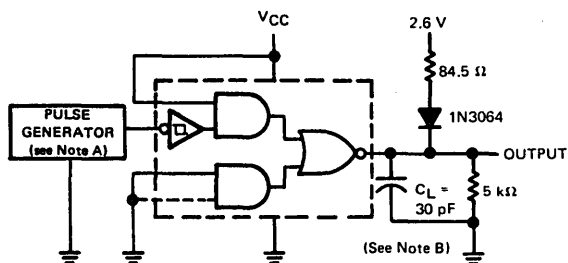

TEST CIRCUIT

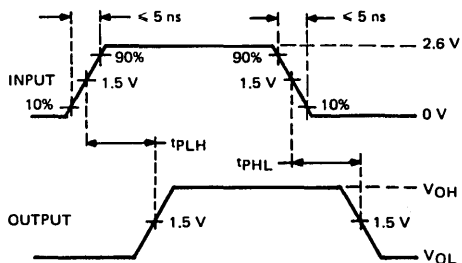

VOLTAGE WAVEFORMS

FIGURE 2—SN75124 SWITCHING TIMES

NOTES: A. The pulse generator has the following characteristics:  $Z_{out} \approx 50 \Omega$ ;  $t_w = 200 \text{ ns}$ , duty cycle = 50%.  
B.  $C_L$  includes probe and jig capacitance.

# TYPES SN75123, SN75124

## DUAL LINE DRIVER AND TRIPLE LINE RECEIVER

### TYPICAL CHARACTERISTICS

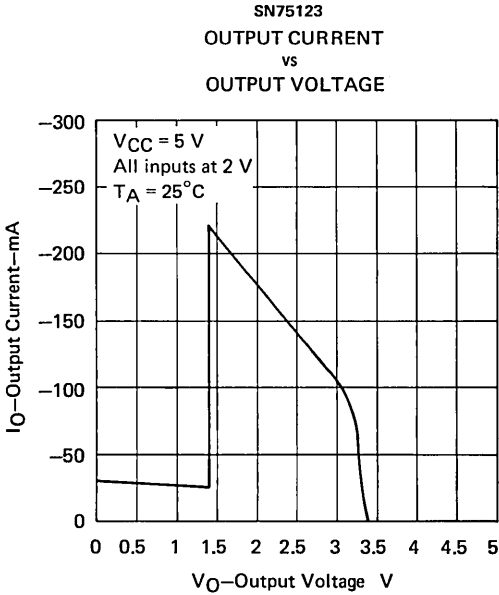

FIGURE 3

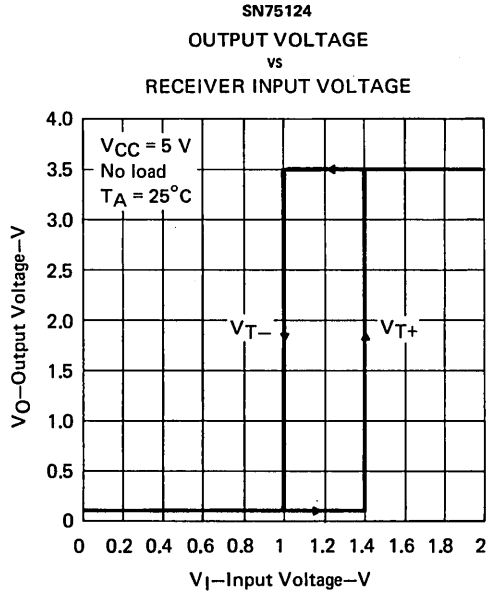

FIGURE 4

### TYPICAL APPLICATION DATA

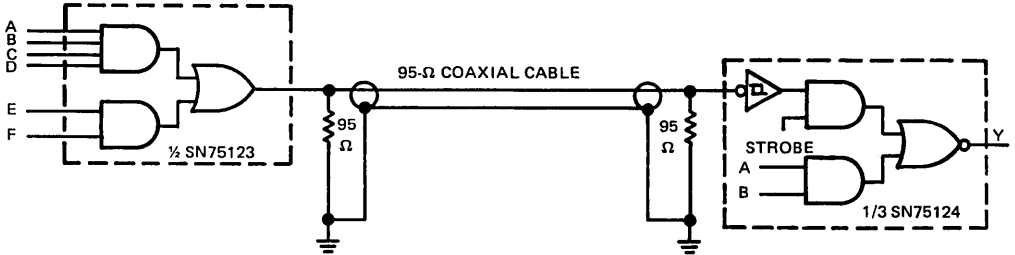

FIGURE 5—UNBALANCED LINE COMMUNICATION USING '123 AND '124

# INTERFACE CIRCUITS

# TYPES SN75125, SN75127 SEVEN-CHANNEL LINE RECEIVERS

BULLETIN NO. DL-S 12457, JANUARY 1977 — REVISED SEPTEMBER 1980

- Meets IBM 360/370 I/O Specification
- Input Resistance . . . 7 kΩ to 20 kΩ
- Output Compatible with DTL or TTL
- Schottky-Clamped Transistors†
- Operates from Single 5-V Supply
- High Speed . . . Low Propagation Delay
- Ratio Specification for Propagation Delay Time, Low-to-High/High-to-Low
- Seven Channels in one 16-Pin Package
- Standard V<sub>CC</sub> and Ground Positioning on SN75127

### description

The SN75125 and SN75127 are monolithic seven-channel line receivers designed to satisfy the requirements of the IBM System 360/370 input/output interface specifications. Special low-power design and Schottky clamped transistors allow for low supply-current requirements while maintaining fast switching speeds and high-current TTL outputs. The SN75125 and SN75127 are characterized for operation from 0°C to 70°C.

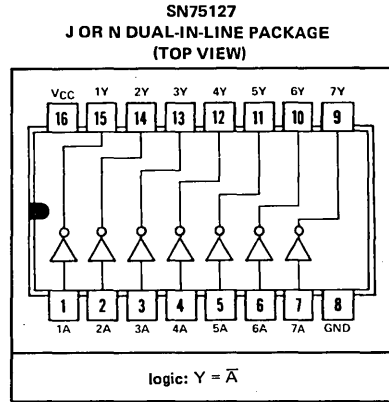
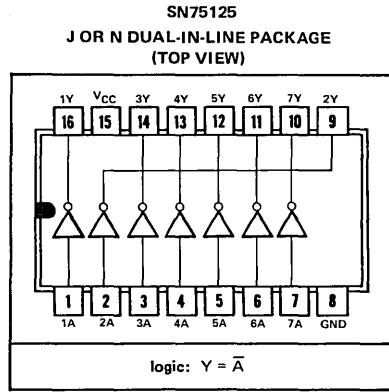

### schematic (each receiver)

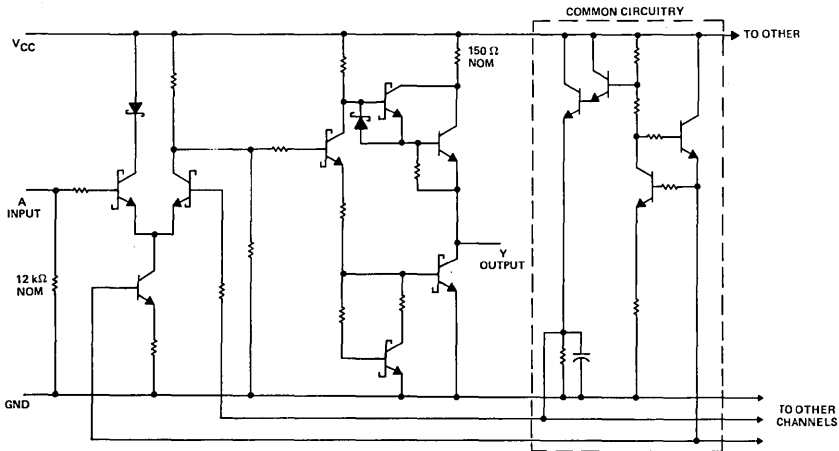

**TEXAS INSTRUMENTS**  
INCORPORATED

POST OFFICE BOX 225012 • DALLAS, TEXAS 75265

†Integrated Schottky-Barrier diode-clamped transistor is patented by Texas Instruments. U. S. Patent Number 3,463,975.

# TYPES SN75125, SN75127

## SEVEN-CHANNEL LINE RECEIVERS

absolute maximum ratings over operating free-air temperature range (unless otherwise noted)

Supply voltage, $V_{CC}$ (see Note 1)	7 V
Input voltage range: SN75125	-0.15 V to 7 V
SN75127	-2 V to 7 V
Continuous total dissipation at (or below) 25°C free-air temperature (see Note 2)	800 mW
Operating free-air temperature range	0°C to 70°C
Storage temperature range	-65°C to 150°C
Lead temperature 1/16 inch from case for 60 seconds: J package	300°C
Lead temperature 1/16 inch from case for 10 seconds: N package	260°C

- NOTES: 1. All voltage values are with respect to network ground terminal.  
 2. For operation above 25°C free-air temperature, refer to Dissipation Derating Curves in the Thermal Information Section, which starts on page 2-1. In the J package, SN75125 and SN75127 chips are glass-mounted.

recommended operating conditions

	MIN	NOM	MAX	UNIT
Supply voltage, $V_{CC}$	4.5	5	5.5	V
High-level output current, $I_{OH}$			-0.4	mA
Low-level output current, $I_{OL}$			16	mA
Operating free-air temperature, $T_A$	0		70	°C

electrical characteristics over recommended operating free-air temperature range (unless otherwise noted)

PARAMETER	TEST CONDITIONS	MIN	TYP <sup>†</sup>	MAX	UNIT	
$V_{IH}$	High-level input voltage	1.7			V	
$V_{IL}$	Low-level input voltage			0.7	V	
$V_{OH}$	High-level output voltage	$V_{CC} = 4.5$ V, $V_{IL} = 0.7$ V, $I_{OH} = -0.4$ mA	2.4	3.1	V	
$V_{OL}$	Low-level output voltage	$V_{CC} = 4.5$ V, $V_{IH} = 1.7$ V, $I_{OL} = 16$ mA		0.4	0.5	V
$I_{IH}$	High-level input current	$V_{CC} = 5.5$ V, $V_I = 3.11$ V		0.3	0.42	mA
$I_{IL}$	Low-level input current	$V_{CC} = 5.5$ V, $V_I = 0.15$ V			30	μA
$I_{OS}$	Short-circuit output current <sup>‡</sup>	$V_{CC} = 5.5$ V, $V_O = 0$	-18		-60	mA
$r_i$	Input resistance	$V_{CC} = 4.5$ V, 0 V, or open, $\Delta V_I = 0.15$ V to 4.15 V	7		20	kΩ
$I_{CC}$	Supply current	$V_{CC} = 5.5$ V, $I_{OH} = -0.4$ mA, All inputs at 0.7 V		15	25	mA
		$V_{CC} = 5.5$ V, $I_{OL} = 16$ mA, All inputs at 4 V		28	47	mA

<sup>†</sup>All typical values are at  $V_{CC} = 5$  V,  $T_A = 25^\circ\text{C}$ .

<sup>‡</sup>Not more than one output should be shorted at a time.

switching characteristics,  $V_{CC} = 5$  V,  $T_A = 25^\circ\text{C}$

PARAMETER	TEST CONDITIONS	MIN	TYP	MAX	UNIT
$t_{PLH}$	Propagation delay time, low-to-high-level output	7	14	25	ns
$t_{PHL}$	Propagation delay time, high-to-low-level output	10	18	30	ns
$\frac{t_{PLH}}{t_{PHL}}$	Ratio of propagation delay times	0.5	0.8	1.3	ns
$t_{TLH}$	Transition time, low-to-high-level output	1	7	12	ns
$t_{THL}$	Transition time, high-to-low-level output	1	3	12	ns

$R_L = 400 \Omega$ ,  $C_L = 50$  pF, See Figure 1

# TYPES SN75125, SN75127 SEVEN-CHANNEL LINE RECEIVERS

## PARAMETER MEASUREMENT INFORMATION

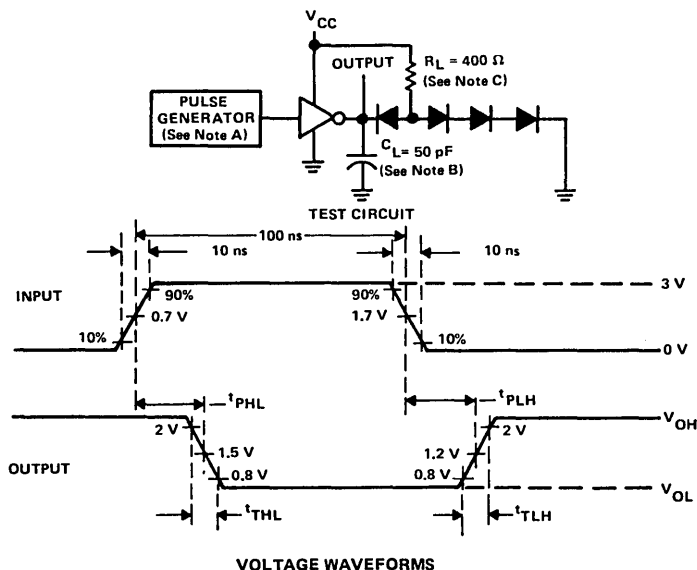

FIGURE 1

- NOTES: A. The pulse generator has the following characteristics:  $Z_{out} \approx 50 \Omega$ , PRR = 5 MHz.  
 B.  $C_L$  includes probe and jig capacitance.  
 C. All diodes are 1N3064 or equivalent.

## TYPICAL CHARACTERISTICS

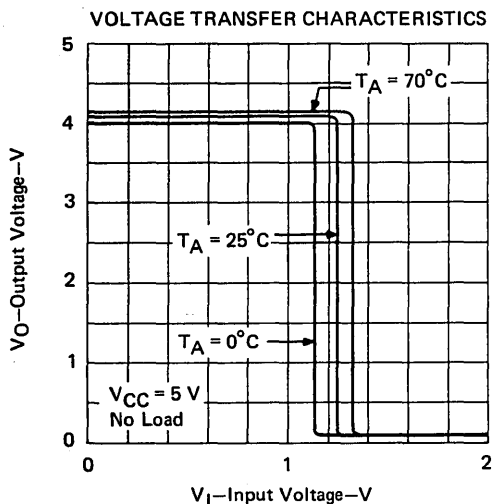

FIGURE 2

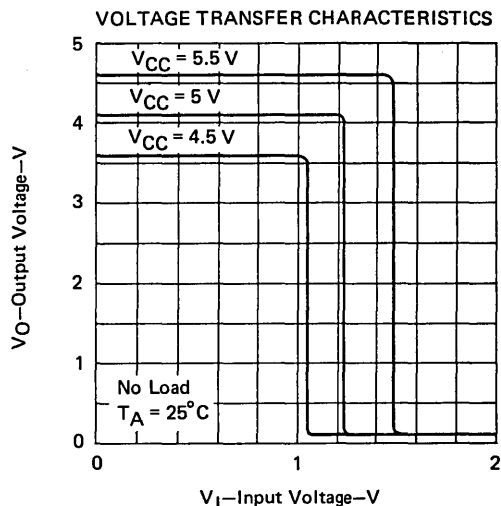

FIGURE 3

**TEXAS INSTRUMENTS**  
INCORPORATED

POST OFFICE BOX 225012 • DALLAS, TEXAS 75265

# TYPES SN75125, SN75127 SEVEN-CHANNEL LINE RECEIVERS

## TYPICAL CHARACTERISTICS

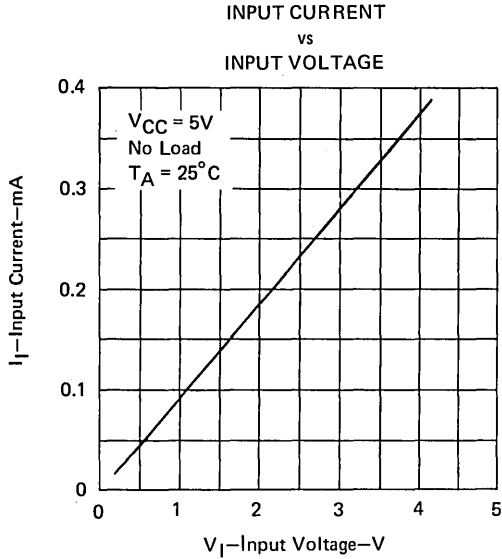

FIGURE 4

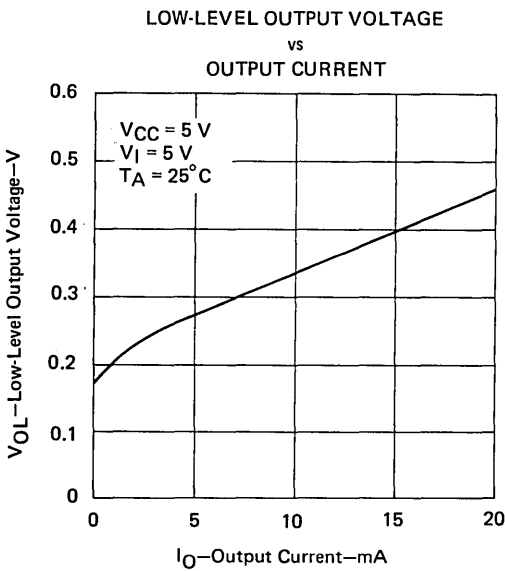

FIGURE 5

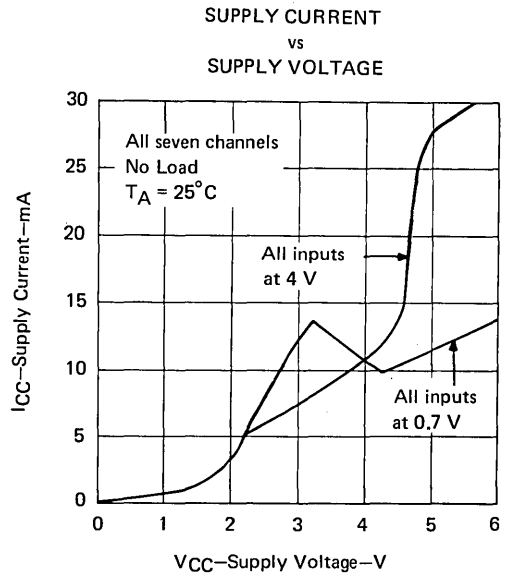

FIGURE 6

**FUTURE PRODUCTS  
TO BE ANNOUNCED**

**TYPE SN75126  
QUADRUPLE LINE DRIVER**

OCTOBER 1980

- Meets IBM 360/370 I/O Interface Specification GA22-6974-3 (Also See SN75130)
- Output Voltage of 3.11 V Min at  $I_{OH} = -60$  mA
- Overload Protection with Foldback Current Limiting
- High-Speed, Low-Power Schottky Circuitry
- Functionally Interchangeable with MC 3481

J OR N PACKAGE  
(TOP VIEW)

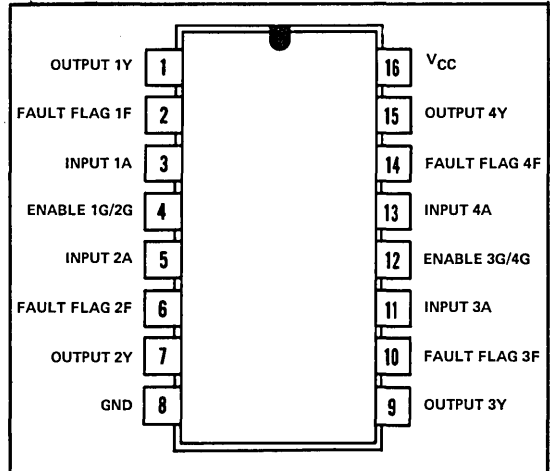

**description**

The SN75126 quadruple line driver is designed to meet the IBM 360/370 I/O specifications GA22-6974-3. The output voltage is 3.11 volts minimum (at  $I_{OH} = -60$  milliamperes) over the recommended ranges of supply voltage (4.5 volts to 5.5 volts) and temperature ( $0^{\circ}\text{C}$  to  $70^{\circ}\text{C}$ ). This device is compatible with standard TTL logic and supply voltages. Fabrication techniques employ low-power-Schottky technology to achieve fast switching and low power dissipation. The data bus will not be disturbed during power up and power down. Fault flag circuitry is designed to sense a line short on any Y output line, output a logic low level, and reduce the output current to a safe level.

The SN75126 is designed for use with the SN75125 or SN75127 seven-channel receivers, or the SN75128 or SN75129 eight-channel receivers.

**functional block diagram (one of four drivers, positive logic)**

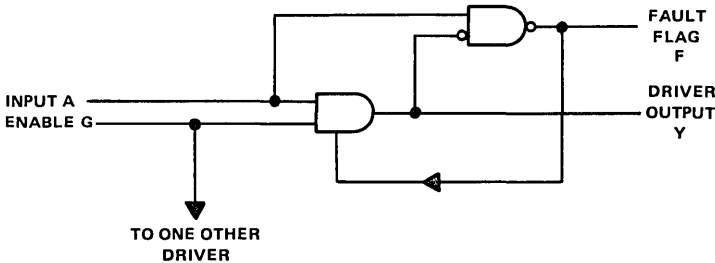

5

**PRODUCT PREVIEW**

This document contains information on a product under development. Texas Instruments reserves the right to change or discontinue this product without notice.

**TEXAS INSTRUMENTS  
INCORPORATED**

POST OFFICE BOX 225012 • DALLAS, TEXAS 75265

# INTERFACE CIRCUITS

# TYPES SN75128, SN75129 EIGHT-CHANNEL LINE RECEIVERS

BULLETIN NO. DL-S 12569, JANUARY 1977 — REVISED SEPTEMBER 1980

- Meets IBM 360/370 I/O Specification
- Input Resistance . . . . . 7 k $\Omega$  to 20 k $\Omega$
- Output Compatible with DTL or TTL
- Schottky-Clamped Transistors<sup>†</sup>
- Operates from a Single 5-Volt Supply
- High-Speed . . . Low Propagation Delay
- Ratio Specification . . . tPLH/tPHL
- Common Strobe for Each Group of Four Receivers
- SN75128 Strobe . . . Active-High  
SN75129 Strobe . . . Active-Low

5

SN75128  
J OR N DUAL IN-LINE PACKAGE  
(TOP VIEW)

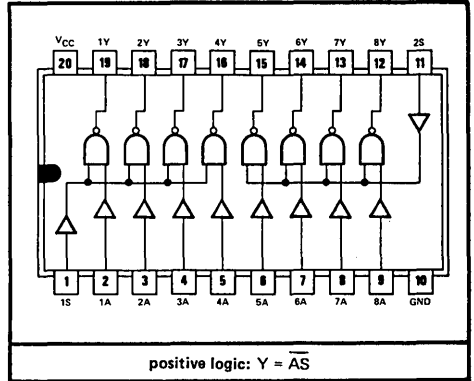

## description

The SN75128 and SN75129 are eight-channel line receivers designed to satisfy the requirements of the input-output interface specification for IBM 360/370. Both devices feature common strobes for each group of four receivers. The SN75128 has an active-high strobe; the SN75129 has an active-low strobe. Special low-power design and Schottky-diode-clamped transistors<sup>†</sup> allow low supply-current requirements while maintaining fast switching speeds and high-current TTL outputs. The SN75128 and SN75129 are characterized for operation from 0°C to 70°C.

SN75129  
J OR N DUAL IN-LINE PACKAGE  
(TOP VIEW)

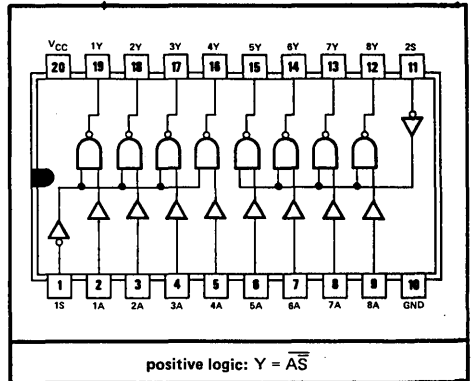



# TYPES SN75128, SN75129 EIGHT-CHANNEL LINE RECEIVERS

schematic (each receiver)

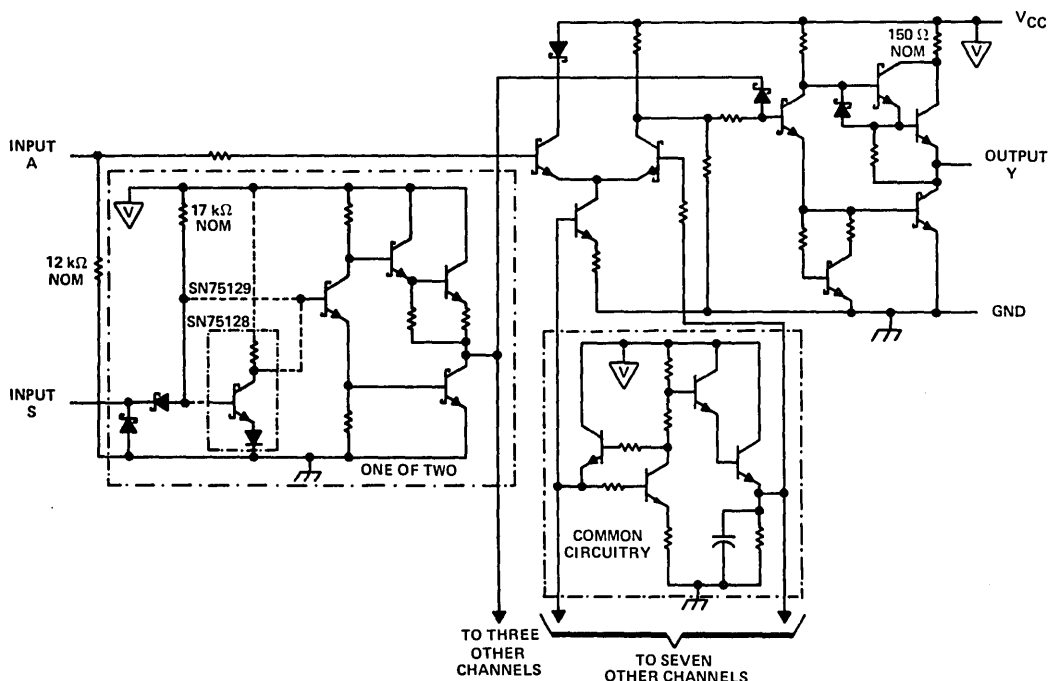

5

## absolute maximum ratings over operating free-air temperature range (unless otherwise noted)

Supply voltage, $V_{CC}$ (see Note 1)	7 V
A input voltage range	-0.15 V to 7 V
Strobe input voltage	7 V
Continuous total dissipation at (or below) 25°C free-air temperature (see Note 2)	800 mW
Operating free-air temperature range	0°C to 70°C
Storage temperature range	-65°C to 150°C
Lead temperature 1/16 inch from case for 60 seconds: J package	300°C
Lead temperature 1/16 inch from case for 10 seconds: N package	260°C

- NOTES: 1. All voltage values are with respect to network ground terminal.  
 2. For operation above 25°C free-air temperature, refer to Dissipation Derating Curves in the Thermal Information section, which starts on page 2-1. In the J package, SN75128 and SN75129 chips are glass-mounted.

## recommended operating conditions

	MIN	NOM	MAX	UNIT
Supply voltage, $V_{CC}$	4.5	5	5.5	V
High-level output current, $I_{OH}$			-0.4	mA
Low-level output current, $I_{OL}$			16	mA
Operating free-air temperature, $T_A$	0		70	°C

TEXAS INSTRUMENTS  
INCORPORATED

POST OFFICE BOX 225012 • DALLAS, TEXAS 75265

5-113

# TYPES SN75128, SN75129

## EIGHT-CHANNEL LINE RECEIVERS

electrical characteristics over recommended operating free-air temperature range (unless otherwise noted)

PARAMETER		TEST CONDITIONS	MIN TYP <sup>†</sup> MAX			UNIT	
V <sub>IH</sub>	High-level input voltage	A	1.7			V	
		S	2				
V <sub>IL</sub>	Low-level input voltage	A	0.7			V	
		S	0.7				
V <sub>OH</sub>	High-level output voltage	V <sub>CC</sub> = 4.5 V, V <sub>I</sub> L = 0.7 V, I <sub>OH</sub> = -0.4 mA	2.4	3.1		V	
V <sub>OL</sub>	Low-level output voltage	V <sub>CC</sub> = 4.5 V, V <sub>I</sub> H = 1.7 V, I <sub>OL</sub> = 16 mA	0.4		0.5	V	
V <sub>IK</sub>	Input clamp voltage	S V <sub>CC</sub> = 4.5 V, I <sub>I</sub> = -18 mA				-1.5	V
I <sub>IH</sub>	High-level input current	A V <sub>CC</sub> = 5.5 V, V <sub>I</sub> = 3.11 V	0.3		0.42	mA	
		S V <sub>CC</sub> = 5.5 V, V <sub>I</sub> = 2.7 V					20
I <sub>IL</sub>	Low-level input current	A V <sub>CC</sub> = 5.5 V, V <sub>I</sub> = 0.15 V				30	μA
		S V <sub>CC</sub> = 5.5 V, V <sub>I</sub> = 0.4 V				-0.4	mA
I <sub>OS</sub>	Short-circuit output current <sup>‡</sup>	V <sub>CC</sub> = 5.5 V, V <sub>O</sub> = 0	-18		-60	mA	
r <sub>I</sub>	Input resistance	V <sub>CC</sub> = 4.5 V, 0 V, or open; ΔV <sub>I</sub> = 0.15 V to 4.15 V	7		20	kΩ	
I <sub>CC</sub>	Supply current	SN75128 V <sub>CC</sub> = 5.5 V, Strobe at 2.4 V, All A inputs at 0.7 V	19		31	mA	
		SN75129 V <sub>CC</sub> = 5.5 V, Strobe at 0.4 V, All A inputs at 0.7 V	19		31		
		SN75128 V <sub>CC</sub> = 5.5 V, Strobe at 2.4 V, All A inputs at 4 V	32		53		
		SN75129 V <sub>CC</sub> = 5.5 V, Strobe at 0.4 V, All A inputs at 4 V	32		53		

<sup>†</sup>All typical values are at V<sub>CC</sub> = 5 V, T<sub>A</sub> = 25°C.

<sup>‡</sup>Not more than one output should be shorted at a time.

switching characteristics, V<sub>CC</sub> = 5 V, T<sub>A</sub> = 25°C

PARAMETER	FROM	TEST CONDITIONS	SN75128			SN75129			UNIT
			MIN	TYP	MAX	MIN	TYP	MAX	
t <sub>PLH</sub>	A	R <sub>L</sub> = 400 Ω, C <sub>L</sub> = 50 pF, See Figure 1	7	14	25	7	14	25	ns
t <sub>PHL</sub>			10	18	30	10	18	30	ns
t <sub>PLH</sub>	S		26	40		20	35		ns
t <sub>PHL</sub>			22	35		16	30		ns
t <sub>PLH</sub> /t <sub>PHL</sub>	A		0.5	0.8	1.3	0.5	0.8	1.3	
t <sub>TLH</sub>			1	7	12	1	7	12	ns
t <sub>THL</sub>		1	3	12	1	3	12	ns	

### PARAMETER MEASUREMENT INFORMATION

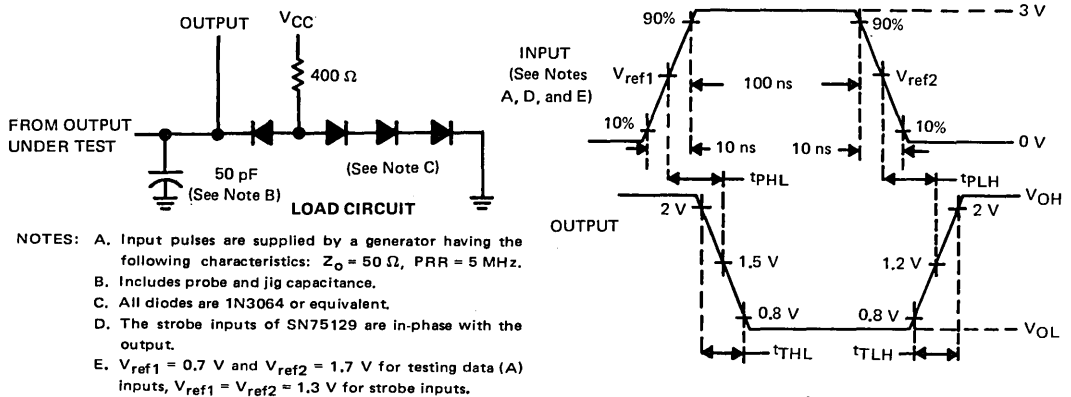

FIGURE 1

# TYPES SN75128, SN75129 EIGHT-CHANNEL LINE RECEIVERS

## TYPICAL CHARACTERISTICS

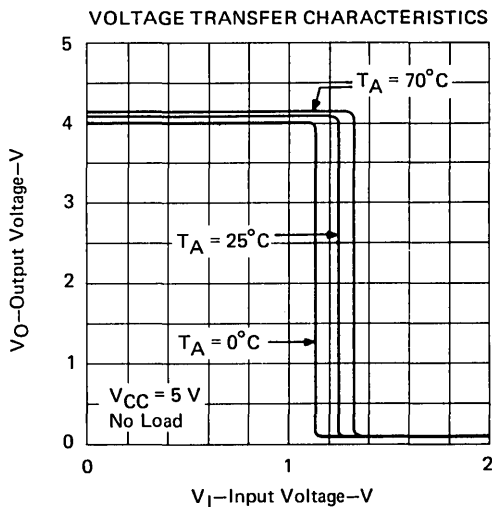

FIGURE 2

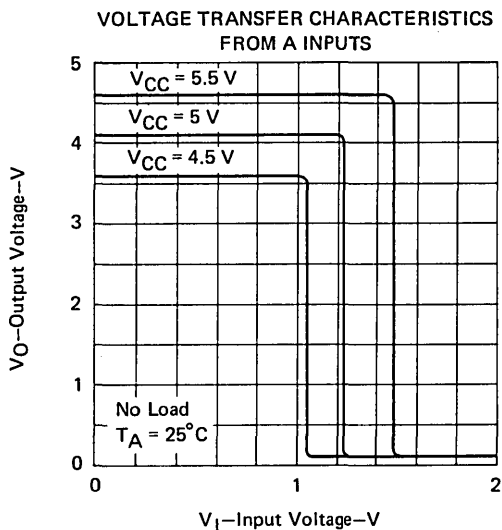

FIGURE 3

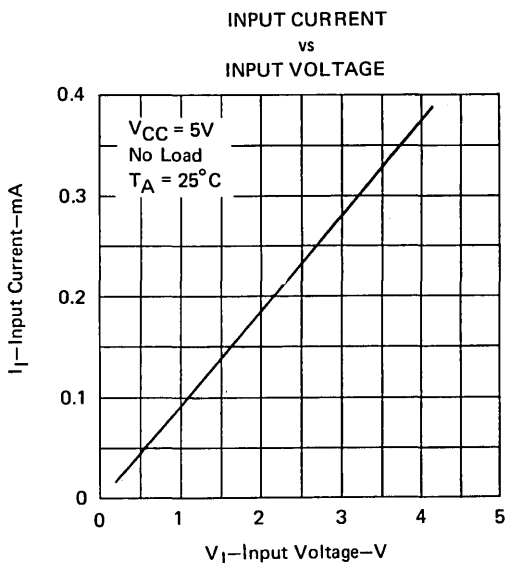

FIGURE 4

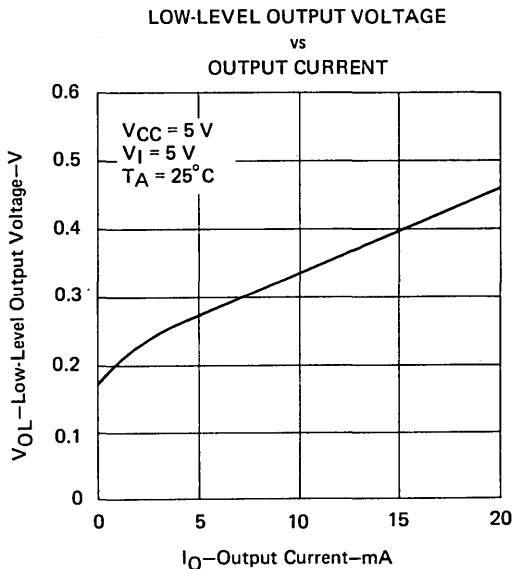

FIGURE 5

# FUTURE PRODUCTS TO BE ANNOUNCED

# TYPE SN75130 QUADRUPLE LINE DRIVER

OCTOBER 1980

- Meets IBM 360/370 I/O Interface Specification GA22-6974-3 (Also See SN75126)
- Output Voltage of 3.11 V Min at  $I_{OH} = -60$  mA
- Overload Protection with Foldback Current Limiting
- Common Enable and Common Fault Flag
- High-Speed, Low-Power Schottky Circuitry
- Functionally Interchangeable with MC 3485

### description

The SN75130 quadruple line driver is designed to meet the IBM 360/370 I/O Specifications GA22-6974-3. The output voltage is 3.11 volts minimum (at  $I_{OH} = -60$  milliamperes) over the recommended ranges of supply voltage (4.5 volts to 5.5 volts) and temperature ( $0^{\circ}\text{C}$  to  $70^{\circ}\text{C}$ ). This device is compatible with standard TTL logic and supply voltages. Fabrication techniques employ low-power Schottky technology to achieve fast switching and low power dissipation. The data bus will not be disturbed during power up and power down. Fault-flag circuitry is designed to sense a short on any of the Y output lines, output a logic low level, and reduce the output current on the shorted line to a safe level.

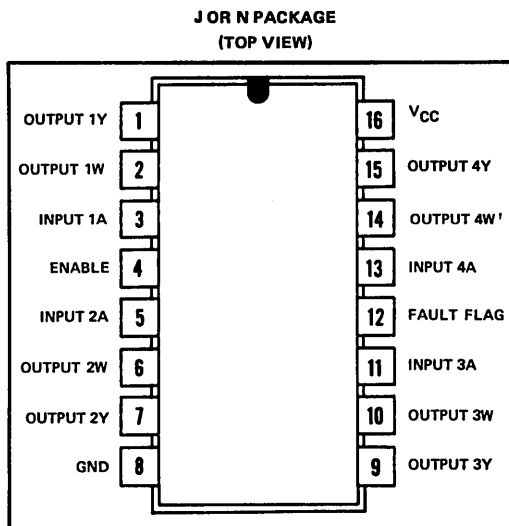

### functional block diagram (one of four drivers, positive logic)

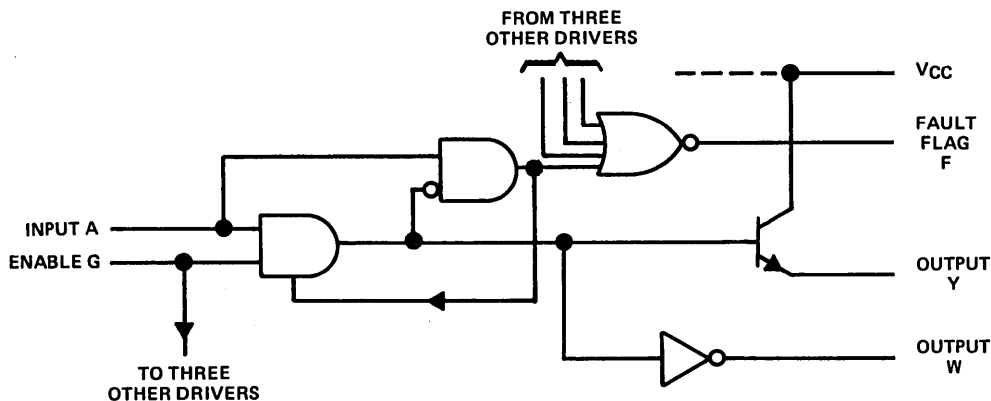

### PRODUCT PREVIEW

5-116

This document contains information on a product under development. Texas Instruments reserves the right to change or discontinue this product without notice.

**TEXAS INSTRUMENTS**  
INCORPORATED

POST OFFICE BOX 225012 • DALLAS, TEXAS 75265

# INTERFACE CIRCUITS

# TYPE SN75136 QUADRUPLE BUS TRANSCEIVER WITH 3-STATE OUTPUTS

BULLETIN NO. DL-S 12485, JANUARY 1977

- P-N-P Inputs for Minimal Input Loading (200  $\mu$ A Maximum)
- High-Speed Schottky Circuitry<sup>†</sup>
- 3-State Outputs for Driver and Receiver
- Party-Line (Data-Bus) Operation
- Single 5-V Supply
- 40-mA Current Sink Capability (Driver)
- Designed to be Functionally Interchangeable with Signetics N8T26

## description

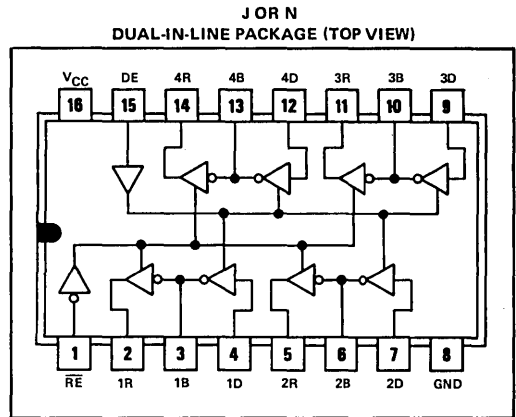

The SN75136 is a quadruple transceiver utilizing Schottky-diode-clamped transistors. Both the driver and receiver have three-state outputs. With p-n-p inputs, the input loading is minimized to a maximum input current of 200  $\mu$ A.

The SN75136 is characterized for operation from 0°C to 70°C.

## schematics of inputs and outputs

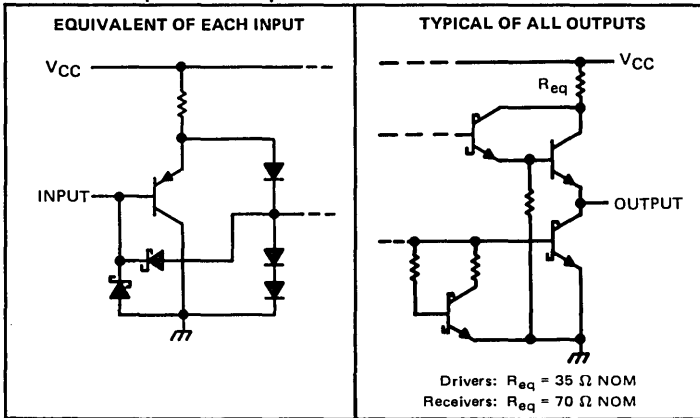

## FUNCTION TABLE (DRIVER)

INPUTS		OUTPUT
D	DE	B
L	H	H
H	H	L
X	L	Z

## FUNCTION TABLE (RECEIVER)

INPUTS		OUTPUT
B	RE	R
L	L	H
H	L	L
X	H	Z

H = high level, L = low level,  
X = irrelevant, Z = high impedance

## absolute maximum ratings over operating free-air temperature range (unless otherwise noted)

Supply voltage, $V_{CC}$ (see Note 1)	7 V
Input voltage	5.5 V
Continuous total dissipation at (or below) 25°C free-air temperature (see Note 2):	
N package	1150 mW
J package	1025 mW
Operating free-air temperature range	0°C to 70°C
Storage temperature range	-65°C to 150°C
Lead temperature 1/16 inch from case for 60 seconds: J package	300°C
Lead temperature 1/16 inch from case for 10 seconds: N package	260°C

NOTES: 1. Voltage values are with respect to network ground terminal.

2. For operation above 25°C free-air temperature, refer to Dissipation Derating Curves in the Thermal Information Section, which starts on page 2-1. In the J package, SN75136 chips are glass-mounted.

TEXAS INSTRUMENTS  
INCORPORATED

POST OFFICE BOX 225012 • DALLAS, TEXAS 75265

<sup>†</sup>Integrated Schottky-Barrier diode-clamped transistor is patented by Texas Instruments. U.S. Patent Number 3,463,975.

# TYPE SN75136

## QUADRUPLE BUS TRANSCEIVER WITH 3-STATE OUTPUTS

### recommended operating conditions

		MIN	NOM	MAX	UNIT
Supply voltage, $V_{CC}$		4.75	5	5.25	V
High-level output current, $I_{OH}$	Driver	-10			mA
	Receiver	-2			
Low-level output current, $I_{OL}$	Driver	40			mA
	Receiver	16			
Operating free-air temperature, $T_A$		0		70	°C

### electrical characteristics over recommended operating free-air temperature and supply voltage ranges (unless otherwise noted)

PARAMETER		TEST CONDITIONS		MIN	TYP†	MAX	UNIT
$V_{IH}$	High-level input voltage	B, D, DE, $\overline{RE}$		2			V
$V_{IL}$	Low-level input voltage	B, D, DE, $\overline{RE}$				0.85	V
$V_{IK}$	Input clamp voltage	B, D, DE, $\overline{RE}$	$I_I = -5$ mA			-1	V
$V_{OH}$	High-level output voltage	B	$V_{IH} = 2$ V, $V_{IL} = 0.85$ V, $I_{OH} = -10$ mA	2.6	3.1		V
		R	$V_{IL} = 0.85$ V, $I_{OH} = -2$ mA	2.6	3.1		
$V_{OL}$	Low-level output voltage	B	$V_{IH} = 2$ V, $I_{OL} = 40$ mA			0.5	V
		R	$V_{IH} = 2$ V, $V_{IL} = 0.85$ V, $I_{OL} = 16$ mA			0.5	
$I_{OZ}$	Off-state (high-impedance state) output current	B, R	DE at 0.85 V $\overline{RE}$ at 2 V, $V_O = 2.6$ V			100	$\mu$ A
		R	$\overline{RE}$ at 2 V, $V_O = 0.5$ V			-100	
$I_{IH}$	High-level input current	D, DE, $\overline{RE}$	$V_I = 5.25$ V			25	$\mu$ A
$I_{IL}$	Low-level input current	B, D, DE, $\overline{RE}$	$V_I = 0.4$ V			-200	$\mu$ A
$I_{OS}$	Short-circuit output current§	B	$V_{CC} = 5.25$ V	-50	-150		mA
		R		-30	-75		
$I_{CC}$	Supply current		$V_{CC} = 5.25$ V, No load			87	mA

† All typical values are at  $T_A = 25^\circ\text{C}$  and  $V_{CC} = 5$  V.

§ Only one output should be shorted at a time, and duration of the short-circuit should not exceed one second.

### switching characteristics, $V_{CC} = 5$ V, $T_A = 25^\circ\text{C}$

PARAMETER	FROM	TO	TEST CONDITIONS	MIN	TYP	MAX	UNIT
$tp_{LH}$	B	R	$C_L = 30$ pF, See Figure 1	8	18		ns
$tp_{HL}$				7	14		
$tp_{LH}$	D	B	$C_L = 300$ pF, See Figure 2	11	20		ns
$tp_{HL}$				16	24		
$tp_{LZ}$	$\overline{RE}$	R	$C_L = 30$ pF, See Figure 3	16	24		ns
$tp_{ZL}$				15	30		
$tp_{LZ}$	DE	B	$C_L = 300$ pF, See Figure 4	9	24		ns
$tp_{ZL}$				31	38		

# TYPE SN75136 QUADRUPLE BUS TRANSCEIVER WITH 3-STATE OUTPUTS

## PARAMETER MEASUREMENT INFORMATION

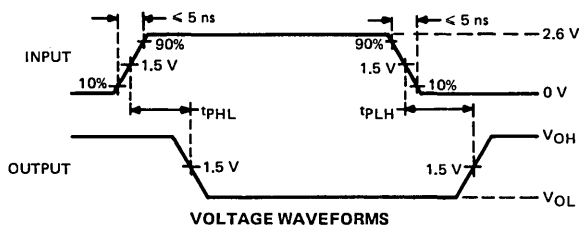
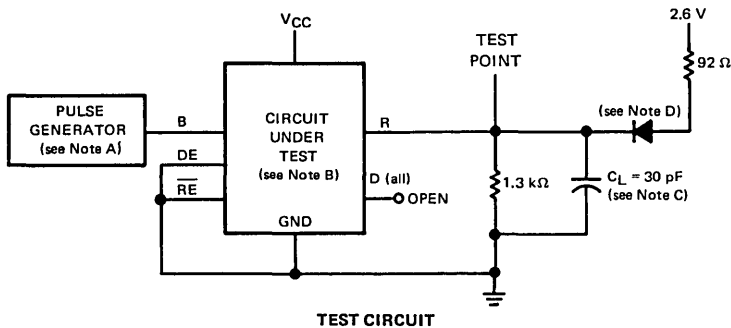

**FIGURE 1—PROPAGATION DELAY TIMES FROM BUS TO RECEIVER OUTPUT**

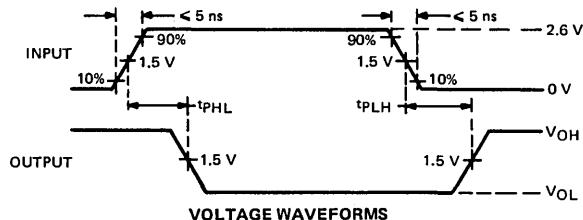
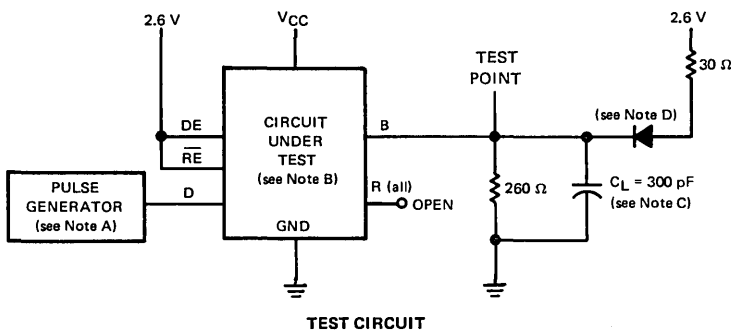
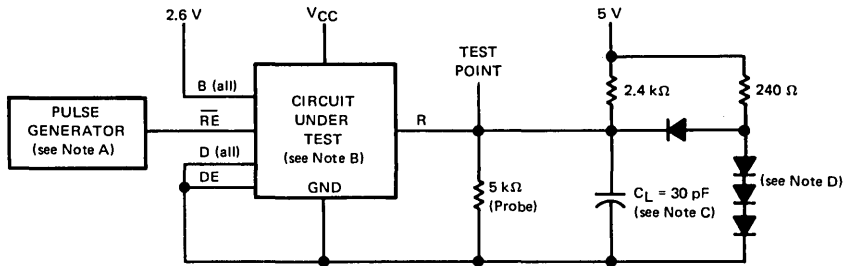

**FIGURE 2—PROPAGATION DELAY TIMES FROM DRIVER INPUT TO BUS**

- NOTES: A. The pulse generator in Figures 1 and 2 has the following characteristics: PRR = 10 MHz, duty cycle = 50%,  $Z_{out} \approx 50 \Omega$ .  
 B. All inputs and outputs not shown are open.  
 C.  $C_L$  includes probe and jig capacitance.  
 D. All diodes are 1N916 or 1N3064.

# TYPE SN75136 QUADRUPLE BUS TRANSCEIVER WITH 3-STATE OUTPUTS

## PARAMETER MEASUREMENT INFORMATION



TEST CIRCUIT

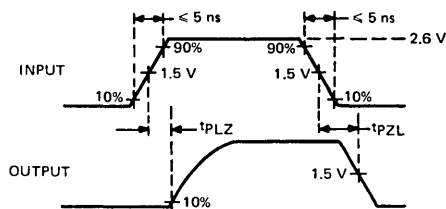

VOLTAGE WAVEFORMS

FIGURE 3—RECEIVER ENABLE AND DISABLE TIMES

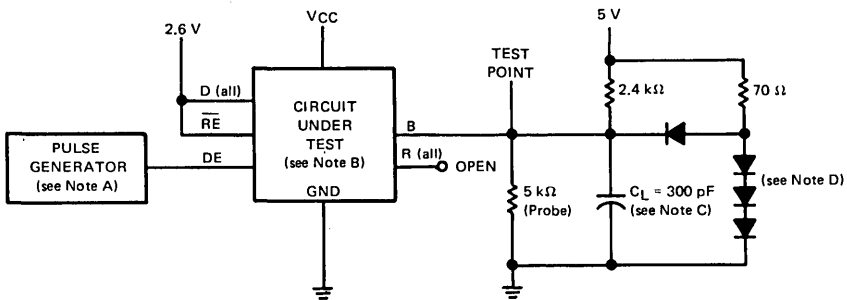

TEST CIRCUIT

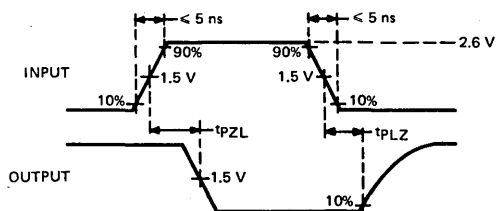

VOLTAGE WAVEFORMS

FIGURE 4—DRIVER ENABLE AND DISABLE TIMES

- NOTES: A. The pulse generator in Figures 3 and 4 has the following characteristics: PRR = 5 MHz, duty cycle = 50%,  $Z_{out} \approx 50 \Omega$ .  
 B. All inputs and outputs not shown are open.  
 C.  $C_L$  includes probe and jig capacitance.  
 D. All diodes are 1N916 or 1N3064.

TEXAS INSTRUMENTS  
INCORPORATED

POST OFFICE BOX 225012 • DALLAS, TEXAS 75265



# INTERFACE CIRCUITS

# TYPES SN55138, SN75138 QUADRUPLE BUS TRANSCEIVERS

BULLETIN NO. DL-S 12046, SEPTEMBER 1973 — REVISED JANUARY 1977

- Single 5-V Supply
- High-Input-Impedance, High-Threshold Receivers
- Common Driver Strobe
- TTL/DTL Compatible Driver and Strobe Inputs with Clamp Diodes

- High-Speed Operation
- 100-mA Open-Collector Driver Outputs
- Four Independent Channels
- TTL Compatible Receiver Output
- Available in Plastic or Ceramic 16-Pin Dual-In-Line Packages

## description

The SN55138 and SN75138 quad bus transceivers are designed for two-way data communication over single-ended transmission lines. Each of the four identical channels consists of a driver with TTL inputs and a receiver with a TTL output. The driver output is of the open-collector type, and is designed to handle loads of up to 100 milliamperes (50 ohms to 5 volts). The receiver input is internally connected to the driver output, and has a high impedance to minimize loading of the transmission line. Because of the high driver-output current and the high receiver-input impedance, a very large number (typically hundreds) of transceivers may be connected to a single data bus.

The receiver design also features a threshold of 2.3 volts (typical), providing a wider noise margin than would be possible with a receiver having the usual TTL threshold. A strobe turns off all drivers (high impedance) but does not affect receiver operation. These circuits are designed for operation from a single five-volt supply and include a provision to minimize loading of the data bus when the power-supply voltage is zero. The SN55138 is characterized for operation over the full military temperature range of  $-55^{\circ}\text{C}$  to  $125^{\circ}\text{C}$ ; the SN75138 is characterized for operation from  $0^{\circ}\text{C}$  to  $70^{\circ}\text{C}$ .

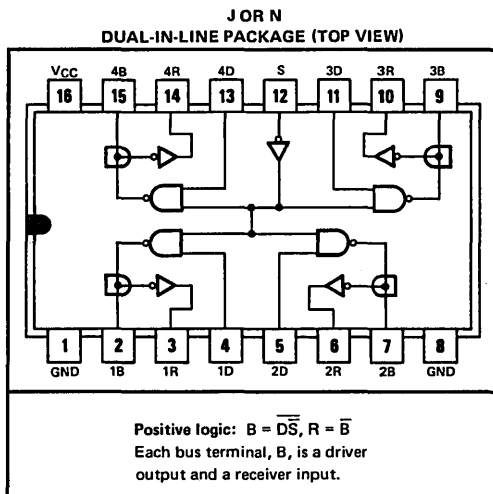

FUNCTION TABLE  
(TRANSMITTING)

INPUTS		OUTPUTS	
S	D	B	R
L	H	L	H
L	L	H	L

FUNCTION TABLE  
(RECEIVING)

INPUTS			OUTPUT
S	B	D	R
H	H	X	L
H	L	X	H

H = high level, L = low level, X = irrelevant

## absolute maximum ratings over operating free-air temperature range (unless otherwise noted)

	SN55138	SN75138	UNIT
Supply voltage, $V_{CC}$ (see Note 1)	7	7	V
Input voltage	5.5	5.5	V
Driver off-state output voltage	7	7	V
Low-level output current into the driver output	150	150	mA
Continuous total dissipation at (or below) $25^{\circ}\text{C}$ free-air temperature (see Note 2)	J package	1375	mW
	N package	1150	
Operating free-air temperature range	$-55$ to $125$	$0$ to $70$	$^{\circ}\text{C}$
Storage temperature range	$-65$ to $150$	$-65$ to $150$	$^{\circ}\text{C}$
Lead temperature 1/16 inch from case for 60 seconds: J package	300	300	$^{\circ}\text{C}$
Lead temperature 1/16 inch from case for 10 seconds: N package		260	$^{\circ}\text{C}$

NOTES: 1. Voltage values are with respect to both ground terminals connected together.

2. For operation above  $25^{\circ}\text{C}$  free-air temperature, refer to the Dissipation Derating Curves in the Thermal Information section, which starts on page 2-1. In the J package, SN55138 chips are alloy-mounted; SN75138 chips are glass-mounted.

TEXAS INSTRUMENTS  
INCORPORATED

POST OFFICE BOX 225012 • DALLAS, TEXAS 75265

# TYPES SN55138, SN75138

## QUADRUPLE BUS TRANSCEIVERS

### recommended operating conditions

		SN55138			SN75138			UNIT
		MIN	NOM	MAX	MIN	NOM	MAX	
Supply voltage, $V_{CC}$		4.5	5	5.5	4.75	5	5.25	V
Low-level output current, $I_{OL}$	Driver output	100			100			mA
	Receiver output	16			16			
High-level output current, $I_{OH}$		-400			-400			$\mu$ A
Operating free-air temperature, $T_A$		-55	125	0	70			$^{\circ}$ C

### electrical characteristics over recommended operating free-air temperature range (unless otherwise noted)

PARAMETER		TEST CONDITIONS†	SN55138			SN75138			UNIT
			MIN	TYP‡	MAX	MIN	TYP‡	MAX	
$V_{IH}$ High-level input voltage	Driver or strobe		2			2			V
	Receiver		3.2			2.9			
$V_{IL}$ Low-level input voltage	Driver or strobe		0.8			0.8			V
	Receiver		1.5			1.8			
$V_{IK}$ Input clamp voltage	Driver or strobe	$V_{CC} = \text{MIN}, I_I = -12 \text{ mA}$	-1.5			-1.5			V
$V_{OH}$ High-level output voltage	Receiver	$V_{CC} = \text{MIN}, V_{IH(S)} = 2 \text{ V}, V_{IL(R)} = V_{IL} \text{ max}, I_{OH} = -400 \mu\text{A}$	2.4	3.5		2.4	3.5		V
$V_{OL}$ Low-level output voltage	Driver	$V_{CC} = \text{MIN}, V_{IH(D)} = 2 \text{ V}, V_{IL(S)} = 0.8 \text{ V}, I_{OL} = 100 \text{ mA}$			0.45			0.45	V
	Receiver	$V_{CC} = \text{MIN}, V_{IH(R)} = V_{IH} \text{ min}, I_{OL} = 16 \text{ mA}$			0.4			0.4	
$I_I$ Input current at maximum input voltage	Driver or strobe	$V_{CC} = \text{MAX}, V_I = V_{CC}$			1			1	mA
$I_{IH}$ High-level input current	Driver or strobe	$V_{CC} = \text{MAX}, V_I = 2.4 \text{ V}$			40			40	$\mu$ A
	Receiver	$V_{CC} = 5 \text{ V}, V_I(R) = 4.5 \text{ V}, V_I(S) = 2 \text{ V}$		25	300		25	300	
$I_{IL}$ Low-level input current	Driver or strobe	$V_{CC} = \text{MAX}, V_I = 0.4 \text{ V}$		-1	-1.6		-1	-1.6	mA
	Receiver	$V_{CC} = \text{MAX}, V_I(R) = 0.45 \text{ V}, V_I(S) = 2 \text{ V}$			-50			-50	$\mu$ A
Input current with power off	Receiver	$V_{CC} = 0, V_I = 4.5 \text{ V}$		1.1	1.5		1.1	1.5	mA
$I_{OS}$ Short-circuit output current§	Receiver	$V_{CC} = \text{MAX}$	-20		-55	-18		-55	mA
$I_{CC}$ Supply current	All driver outputs low	$V_{CC} = \text{MAX}, V_I(D) = 2 \text{ V}, V_I(S) = 0.8 \text{ V}$		50	65		50	65	mA
	All driver outputs high	$V_{CC} = \text{MAX}, V_I(R) = 3.5 \text{ V}, \text{Receiver outputs open}$		42	55		42	55	

† For conditions shown as MIN or MAX, use the appropriate value specified under recommended operating conditions. Parenthetical letters D, R, and S used with  $V_I$  refer to the driver input, receiver input, and strobe input, respectively.

‡ All typical values are at  $V_{CC} = 5 \text{ V}, T_A = 25^{\circ}\text{C}$ .

§ Not more than one output should be shorted at a time.

# TYPES SN55138, SN75138 QUADRUPLE BUS TRANSCEIVERS

switching characteristics,  $V_{CC} = 5\text{ V}$ ,  $T_A = 25^\circ\text{C}$

PARAMETER†	FROM (INPUT)	TO (OUTPUT)	TEST CONDITIONS	MIN	TYP	MAX	UNIT
$t_{PLH}$	Driver	Driver	$C_L = 50\text{ pF}$ , $R_L = 50\ \Omega$ , See Figure 1	15	24		ns
$t_{PHL}$				14	24		
$t_{PLH}$	Strobe	Driver		18	28		ns
$t_{PHL}$				22	32		
$t_{PLH}$	Receiver	Receiver	$C_L = 15\text{ pF}$ , $R_L = 400\ \Omega$ , See Figure 2	7	15		ns
$t_{PHL}$				8	15		

†  $t_{PLH}$   $\equiv$  propagation delay time, low-to-high-level output  
 $t_{PHL}$   $\equiv$  propagation delay time, high-to-low-level output

### schematics of inputs and outputs

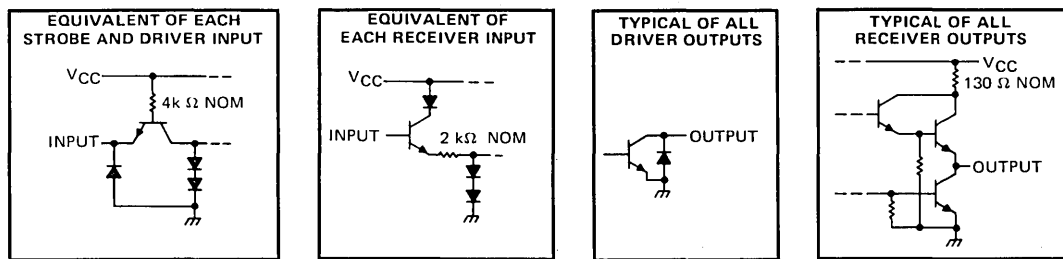

### PARAMETER MEASUREMENT INFORMATION

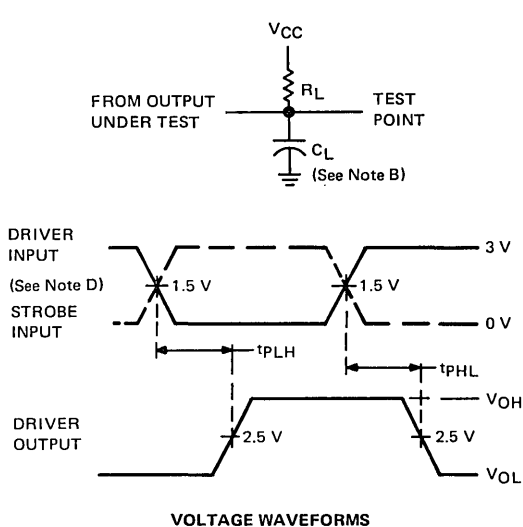

FIGURE 1—PROPAGATION DELAY TIMES FROM DATA AND STROBE INPUTS

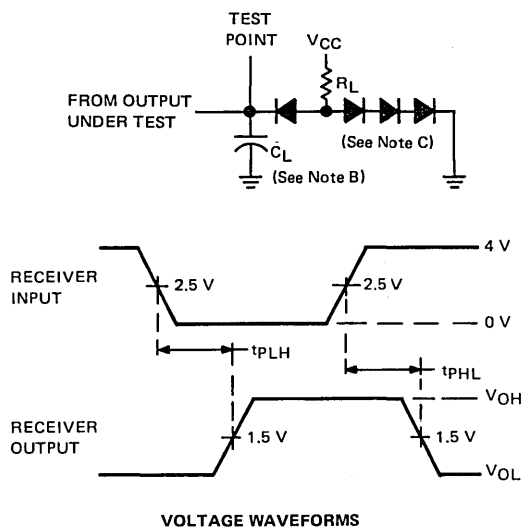
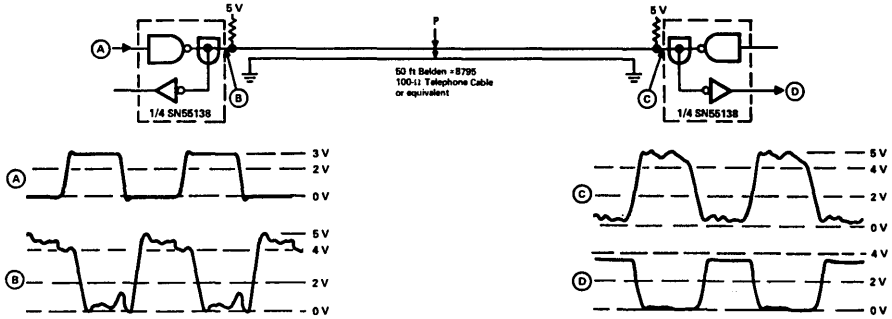

FIGURE 2—PROPAGATION DELAY TIMES FROM RECEIVER INPUT

- NOTES: A. Input pulses are supplied by generators having the following characteristics:  $t_w = 100\text{ ns}$ ,  $\text{PRR} = 1\text{ MHz}$ ,  $t_r < 10\text{ ns}$ ,  $t_f < 10\text{ ns}$ ,  $Z_{out} \approx 50\ \Omega$ .  
 B.  $C_L$  includes probe and jig capacitance.  
 C. All diodes are 1N916 or 1N3064.  
 D. When testing driver input (solid line) strobe must be low; when testing strobe input (dashed line) driver input must be high.

# TYPES SN55138, SN75138 QUADRUPLE BUS TRANSCEIVERS

## TYPICAL APPLICATION DATA



TYPICAL VOLTAGE WAVEFORMS

FIGURE 3—POINT-TO-POINT COMMUNICATION OVER 50 FEET OF TWISTED PAIR AT 5 MHz

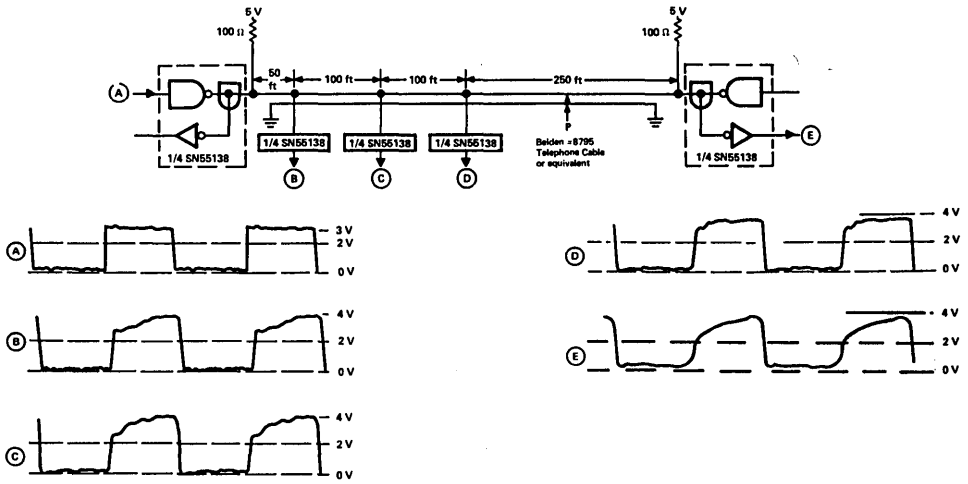

TYPICAL VOLTAGE WAVEFORMS

FIGURE 4—PARTY-LINE COMMUNICATION ON 500 FEET OF TWISTED PAIR AT 1 MHz

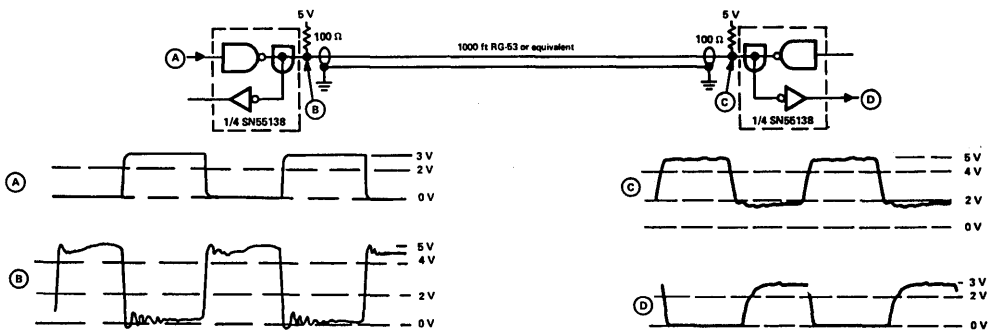

TYPICAL VOLTAGE WAVEFORMS

FIGURE 5—POINT-TO-POINT COMMUNICATION OVER 1000 FEET OF COAX AT 1 MHz

5

# TYPES SN55138, SN75138 QUADRUPLE BUS TRANSCEIVERS

## TYPICAL CHARACTERISTICS†

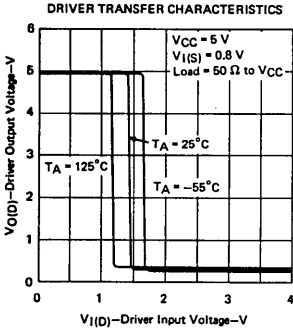

FIGURE 6

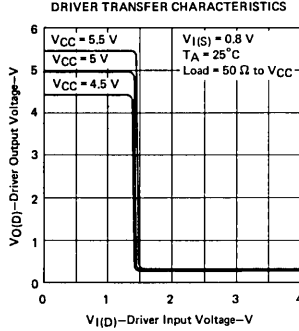

FIGURE 7

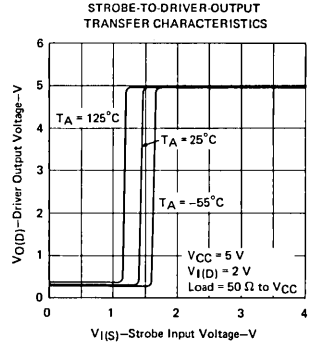

FIGURE 8

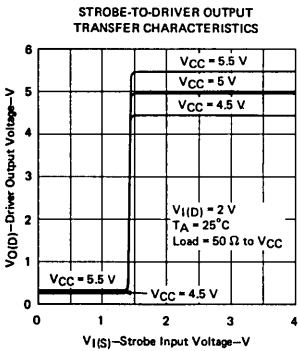

FIGURE 9

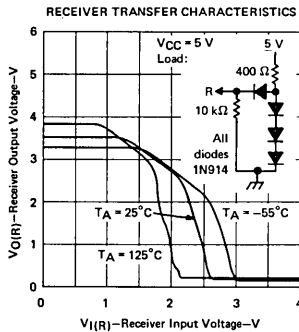

FIGURE 10

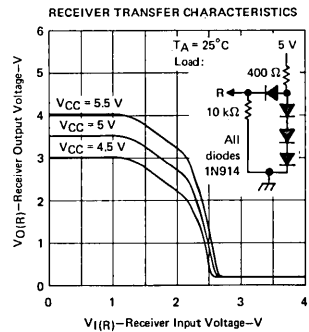

FIGURE 11

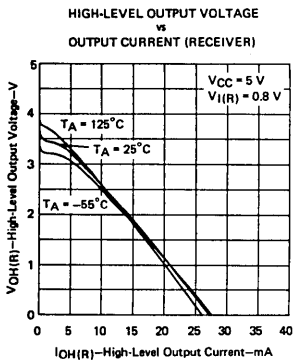

FIGURE 12

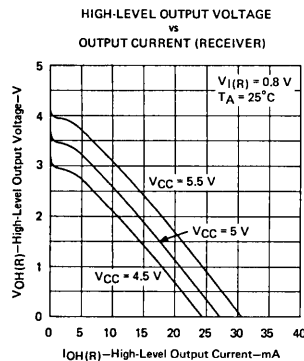

FIGURE 13

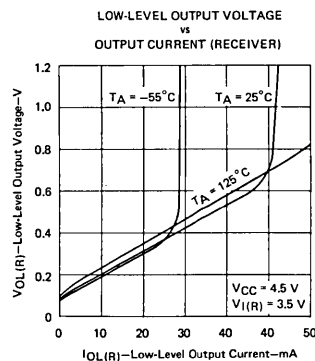

FIGURE 14

† Data for temperatures below 0°C and above 70°C is applicable to SN55138 circuits only.

# TYPES SN55138, SN75138 QUADRUPLE BUS TRANSCEIVERS

## TYPICAL CHARACTERISTICS†

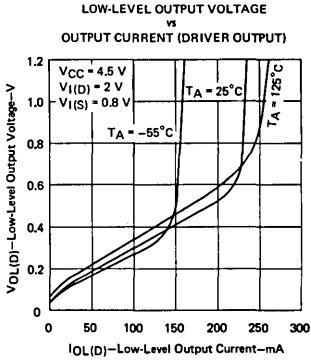

FIGURE 15

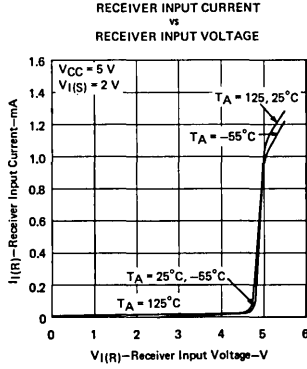

FIGURE 16

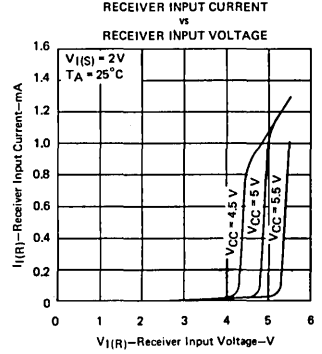

FIGURE 17

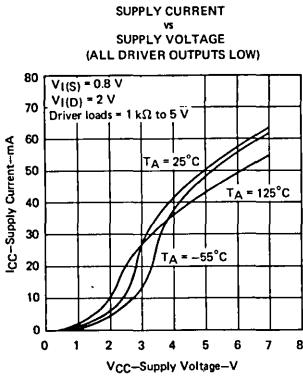

FIGURE 18

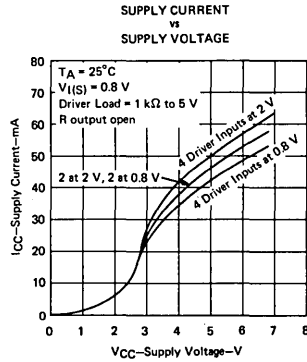

FIGURE 19

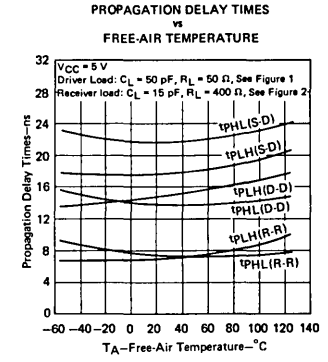

FIGURE 20

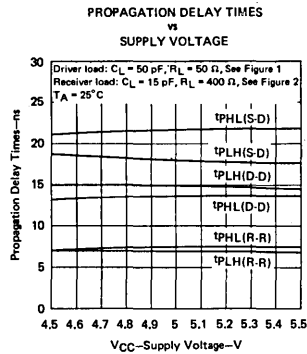

FIGURE 21

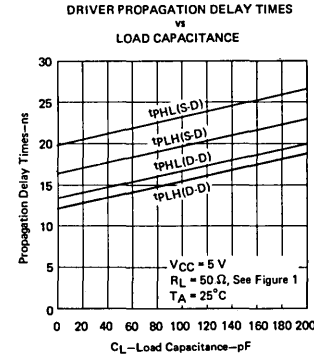

FIGURE 22

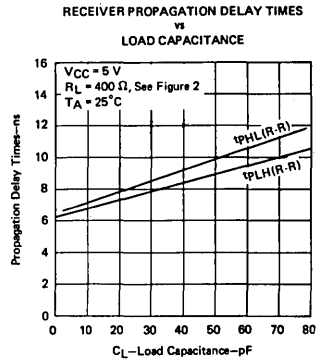

FIGURE 23

†Data for temperatures below 0°C and above 70°C is applicable to SN55138 circuits only.

# INTERFACE CIRCUITS

# TYPES SN55140, SN55141, SN55142A, SN55143A, SN75140, SN75141, SN75142A, SN75143A DUAL LINE RECEIVERS

BULLETIN NO. DL-S 12456, JANUARY 1977—REVISED JULY 1979

features common to all eight types

- Single 5-V Supply
- $\pm 100$  mV Sensitivity
- For Application As:  
Single-Ended Line Receiver  
Gated Oscillator  
Level Comparator
- Adjustable Reference Voltage
- TTL Outputs
- TTL-Compatible Strobe
- Designed for Party-Line  
(Data-Bus) Applications

features of '140 and '141

- Common Reference Pin
- Common Strobe
- '141 Has Diode-Protected  
Input Stage for Power-Off  
Condition

features of '142A and '143A

- Individual Reference Pins
- Common and Individual Strobes
- Internal 2.5-Volt Reference  
Available
- '143A Has Diode-Protected  
Input Stage for Power-Off  
Condition

SN55140, SN55141 . . .  
JG DUAL-IN-LINE PACKAGE  
SN75140, SN75141 . . .  
JG OR P DUAL-IN-LINE PACKAGE  
(TOP VIEW)

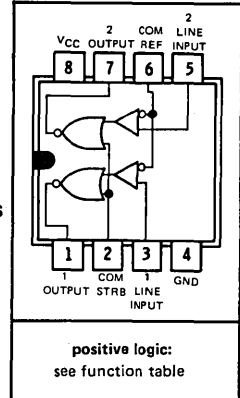

SN55142A, SN55143A . . . J DUAL-IN-LINE PACKAGE  
SN75142A, SN75143A . . . J OR N DUAL-IN-LINE PACKAGE  
(TOP VIEW)

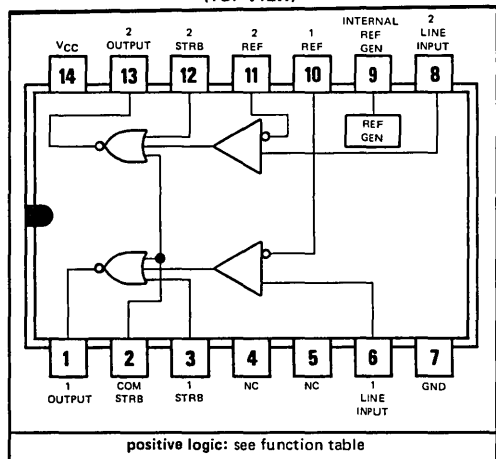

NC—No internal connection

Pin 2, if unused, must be grounded when replacing '142 or '143 with '142A or '143A devices.

## description

Each of these devices consists of a dual single-ended line receiver with TTL-compatible strobes and outputs. The reference voltage (switching threshold) is applied externally and can be adjusted from 1.5 volts to 3.5 volts, making it possible to optimize noise immunity for a given system design. A 2.5-volt internal reference is available for use on the '142A and '143A. Due to their low input current (less than 100 microamperes), they are ideally suited for party-line (bus-organized) systems.

The '140 has a common reference voltage pin and a common strobe. The '141 is the same as the '140 except that the input stage is diode protected. Each receiver of the '142A has an individual reference voltage pin and an individual strobe. The '143A is the same as the '142A except that the input stage is diode protected. The internal reference voltage of the '142A and '143A can be externally adjusted with a single resistor from 1.5 volts to 3.5 volts.

'140, '141 FUNCTION TABLE  
(EACH RECEIVER)

LINE INPUT	STROBE	OUTPUT
$< V_{ref} - 100$ mV	L	H
$> V_{ref} + 100$ mV	X	L
X	H	L

H = high level, L = low level, X = irrelevant

'142A, '143A FUNCTION TABLE  
(EACH RECEIVER)

LINE INPUT	INDIVIDUAL STROBE	COMMON STROBE	OUTPUT
$< V_{REF} - 100$ mV	L	L	H
$> V_{REF} + 100$ mV	X	X	L
X	H	X	L
X	X	H	L

H = high level, L = low level, X = irrelevant

Copyright © 1979 by Texas Instruments Incorporated

TEXAS INSTRUMENTS  
INCORPORATED

POST OFFICE BOX 225012 • DALLAS, TEXAS 75265

# TYPES SN55140, SN55141, SN55142A, SN55143A, SN75140, SN75141, SN75142A, SN75143A DUAL LINE RECEIVERS

schematic (each receiver)

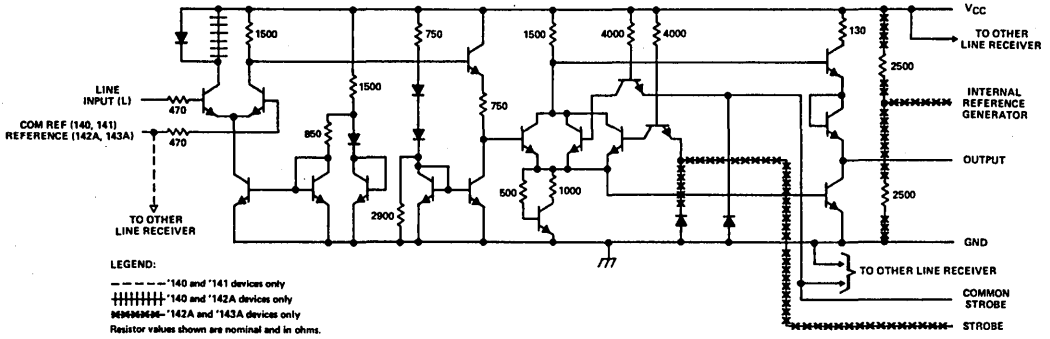

5

absolute maximum ratings over operating free-air temperature range (unless otherwise noted)

Supply voltage, $V_{CC}$ (see Note 1)	7 V
Reference input voltage, $V_{ref}$	5.5 V
Line input voltage with respect to ground	-2 V to 5.5 V
Line input voltage with respect to $V_{ref}$	$\pm 5$ V
Strobe input voltage	5.5 V
Continuous total dissipation at (or below) 25°C free-air temperature (see Note 2)	600 mW
Operating free-air temperature range: SN55' Circuits	-55°C to 125°C
SN75' Circuits	0°C to 70°C
Storage temperature range	-65°C to 150°C
Lead temperature 1/16 inch from case for 60 seconds: J or JG package	300°C
Lead temperature 1/16 inch from case for 10 seconds: N or P package	260°C

- NOTES: 1. Unless otherwise specified, voltage values are with respect to network ground terminal.  
 2. For operation above 25°C free-air temperature, see the Dissipation Derating Table. In the J and JG package, these chips are glass mounted.

DISSIPATION DERATING TABLE

PACKAGE	POWER RATING	DERATING FACTOR	ABOVE $T_A$
J	600 mW	8.2 mW/°C	77°C
JG	600 mW	6.6 mW/°C	59°C
N	600 mW	9.2 mW/°C	85°C
P	600 mW	8.0 mW/°C	75°C

recommended operating conditions

	SN55' CIRCUITS			SN75' CIRCUITS			UNIT
	MIN	NOM	MAX	MIN	NOM	MAX	
Supply voltage, $V_{CC}$	4.5	5	5.5	4.5	5	5.5	V
Reference input voltage, $V_{ref}$	1.5		3.5	1.5		3.5	V
Input voltage, $V_I$	Line	0		$V_{CC}-1$			V
	Strobe	0		5.5			
Operating free-air temperature, $T_A$	-55		125	0		70	°C



# TYPES SN55140, SN55141, SN55142A, SN55143A, SN75140, SN75141, SN75142A, SN75143A DUAL LINE RECEIVERS

electrical characteristics over recommended operating free-air temperature range,  
 $V_{CC} = 5\text{ V} \pm 10\%$ ,  $V_{ref} = 1.5\text{ V to } 3.5\text{ V}$  (unless otherwise noted)

PARAMETER		TEST CONDITIONS	MIN	TYP†	MAX	UNIT	
$V_{IH(L)}$	High-level line input voltage		$V_{ref} + 100$			mV	
$V_{IL(L)}$	Low-level line input voltage				$V_{ref} - 100$	mV	
$V_{IH(S)}$	High-level strobe input voltage		2			V	
$V_{IL(S)}$	Low-level strobe input voltage				0.8	V	
$V_{OH}$	High-level output voltage	$V_{IL(L)} = V_{ref} - 100\text{ mV}$ , $V_{IL(S)} = 0.8\text{ V}$ , $I_{OH} = -400\text{ }\mu\text{A}$	2.4			V	
$V_{OL}$	Low-level output voltage	$V_{IH(L)} = V_{ref} + 100\text{ mV}$ , $V_{IL(S)} = 0.8\text{ V}$ , $I_{OL} = 16\text{ mA}$			0.4	V	
		$V_{IL(L)} = V_{ref} - 100\text{ mV}$ , $V_{IH(S)} = 2\text{ V}$ , $I_{OL} = 16\text{ mA}$			0.4		
$V_{IK(S)}$	Strobe input clamp voltage	$I_I(S) = -12\text{ mA}$			-1.5	V	
$I_I(S)$	Strobe input current at maximum input voltage	Strobe	$V_I(S) = 5.5\text{ V}$		1	mA	
		Com strb			2		
$I_{IH}$	High-level input current	Strobe	$V_I(S) = 2.4\text{ V}$		40	$\mu\text{A}$	
		Com strb			80		
		Line input	$V_I(L) = 3.5\text{ V}$ , $V_{ref} = 1.5\text{ V}$		35		100
		Reference	$V_I(L) = 0\text{ V}$ , $V_{ref} = 3.5\text{ V}$		35		100
		Com ref			70		200
$I_{IL}$	Low-level input current	Strobe	$V_I(S) = 0.4\text{ V}$		-1.6	mA	
		Com strb			-3.2		
		Line input	$V_I(L) = 0\text{ V}$ , $V_{ref} = 1.5\text{ V}$		-10		$\mu\text{A}$
		Reference	$V_I(L) = 1.5\text{ V}$ , $V_{ref} = 0\text{ V}$		-10		
		Com ref			-20		
$V_{gen}$	Internal reference generator voltage‡	'142A, $V_{CC} = 5\text{ V}$ , $I_{gen} = 0$	2.3	2.5	2.7	V	
		'143A, $V_{CC} = 5\text{ V}$ , $I_{gen} = -70\text{ }\mu\text{A}$		2.4			
$I_{OS}$	Short-circuit output current‡	$V_{CC} = 5.5\text{ V}$	-18		-55	mA	
$I_{CCH}$	Supply current, output high	$V_I(S) = 0\text{ V}$ , $V_I(L) = V_{ref} - 100\text{ mV}$		18	30	mA	
$I_{CCL}$	Supply current, output low	$V_I(S) = 0\text{ V}$ , $V_I(L) = V_{ref} + 100\text{ mV}$		20	35	mA	

†All typical values are at  $V_{CC} = 5\text{ V}$ ,  $T_A = 25^\circ\text{C}$ .

‡Only one output should be shorted at a time.

switching characteristics,  $V_{CC} = 5\text{ V}$ ,  $V_{ref} = 2.5\text{ V}$ ,  $T_A = 25^\circ\text{C}$

PARAMETER		TEST CONDITIONS	MIN	TYP	MAX	UNIT
$t_{PLH(L)}$	Propagation delay time, low-to-high-level output from line input	$C_L = 15\text{ pF}$ , $R_L = 400\text{ }\Omega$ , See Figure 1		22	35	ns
$t_{PHL(L)}$	Propagation delay time, high-to-low-level output from line input			22	30	
$t_{PLH(S)}$	Propagation delay time, low-to-high-level output from strobe input			12	22	ns
$t_{PHL(S)}$	Propagation delay time, high-to-low-level output from strobe input			8	15	

5

# TYPES SN55140, SN55141, SN55142A, SN55143A, SN75140, SN75141, SN75142A, SN75143A DUAL LINE RECEIVERS

## PARAMETER MEASUREMENT INFORMATION

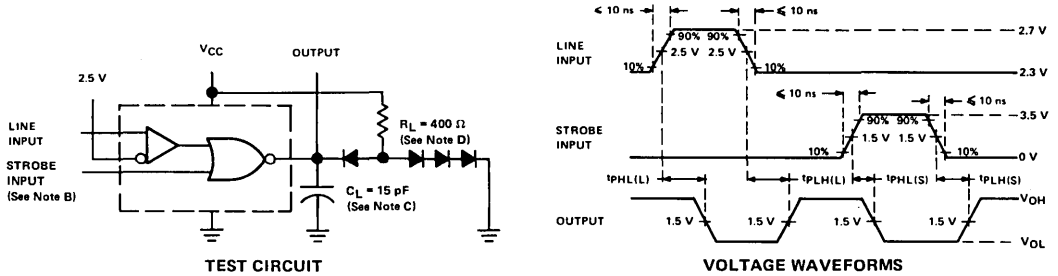

FIGURE 1

- NOTES: A. Input pulses are supplied by generators having the following characteristics: PRR = 1 MHz, duty cycle  $\leq$  50%,  $Z_{out} \approx 50 \Omega$ .  
 B. Unused strobe(s) is (are) to be grounded.  
 C.  $C_L$  includes probe and jig capacitance.  
 D. All diodes are 1N3064.

## TYPICAL CHARACTERISTICS

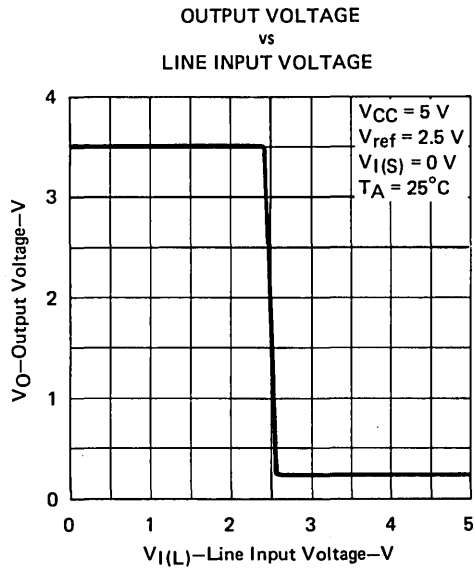
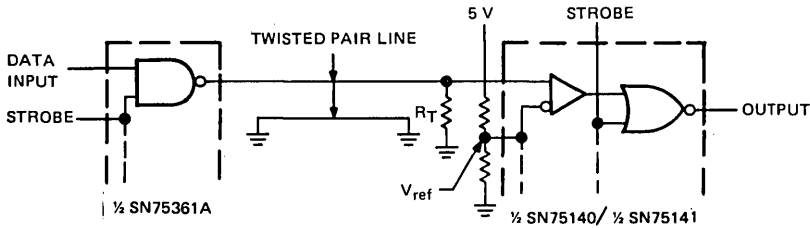

FIGURE 2

# TYPES SN55140, SN55141, SN55142A, SN55143A, SN75140, SN75141, SN75142A, SN75143A DUAL LINE RECEIVERS

## TYPICAL APPLICATION DATA

### line receiver



### high fan-out from standard TTL gate

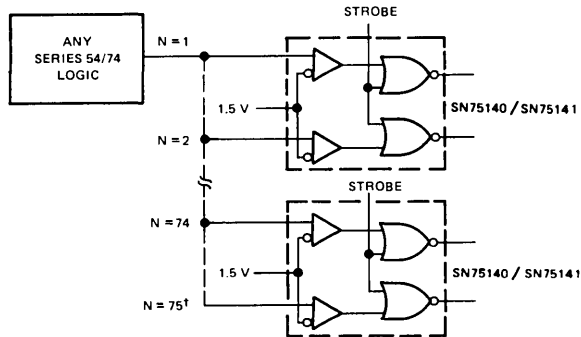

† Although most Series 54/74 circuits have a guaranteed 2.4-V output at 400  $\mu$ A, they are typically capable of maintaining a 2.4-V output level under a load of 7.5 mA.

### dual bus transceiver

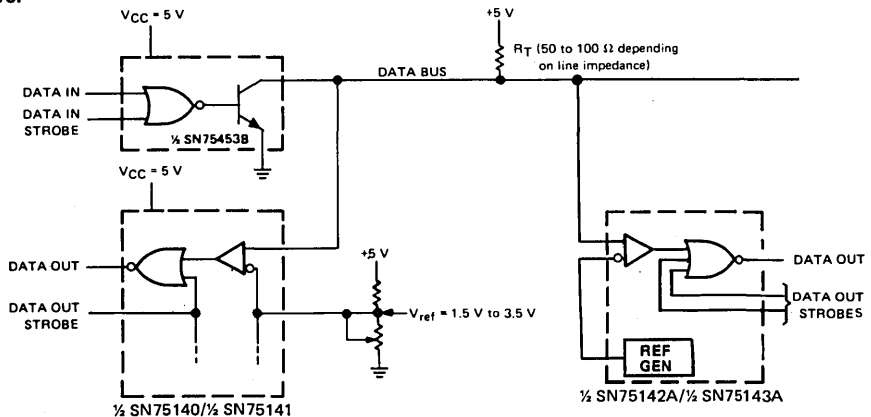

Using this arrangement, as many as 100 transceivers can be connected to a single data bus. The adjustable reference voltage feature allows the noise margin to be optimized for a given system. The complete dual bus transceiver (SN75453B driver and SN75140 receiver) can be assembled in approximately the same space required by a single 16-pin package, and only one power supply is required (+5 V). Data In and Data Out terminals are TTL compatible.

# TYPES SN55140, SN55141, SN55142A, SN55143A, SN75140, SN75141, SN75142A, SN75143A DUAL LINE RECEIVERS

## TYPICAL APPLICATION DATA

### Schmitt trigger

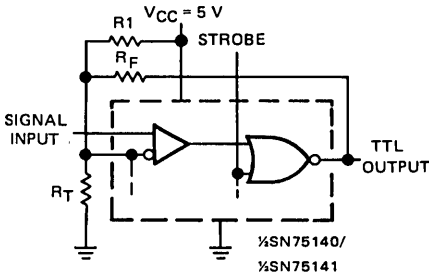

### EXAMPLES OF TRANSFER CHARACTERISTICS

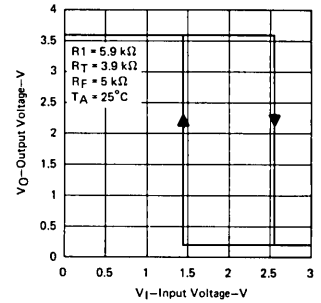
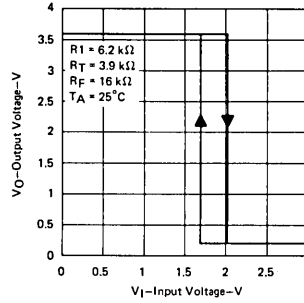

5

Slowly changing input levels from data lines, optical detectors, and other types of transducers may be converted to standard TTL signals with this Schmitt trigger circuit.  $R_1$ ,  $R_F$ , and  $R_T$  may be adjusted for the desired hysteresis and trigger levels.

### gated oscillator

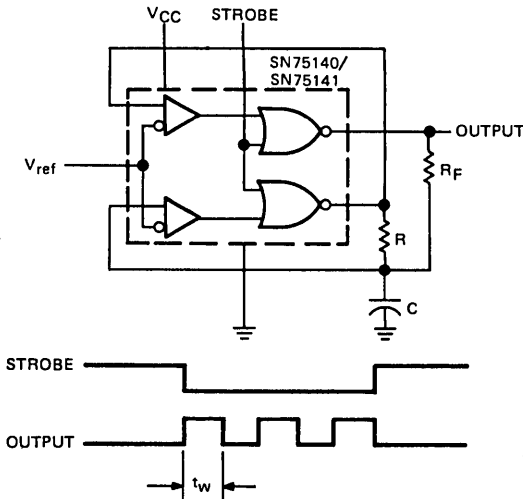

### OSCILLATOR FREQUENCY vs RC TIME CONSTANT

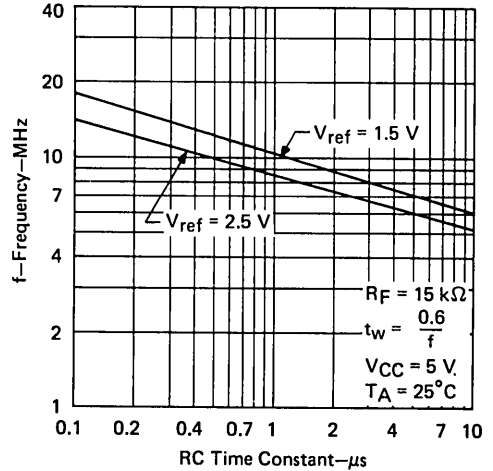

# TYPES SN55140, SN55141, SN55142A, SN55143A, SN75140, SN75141, SN75142A, SN75143A DUAL LINE RECEIVERS

## TYPICAL APPLICATION DATA

level detector

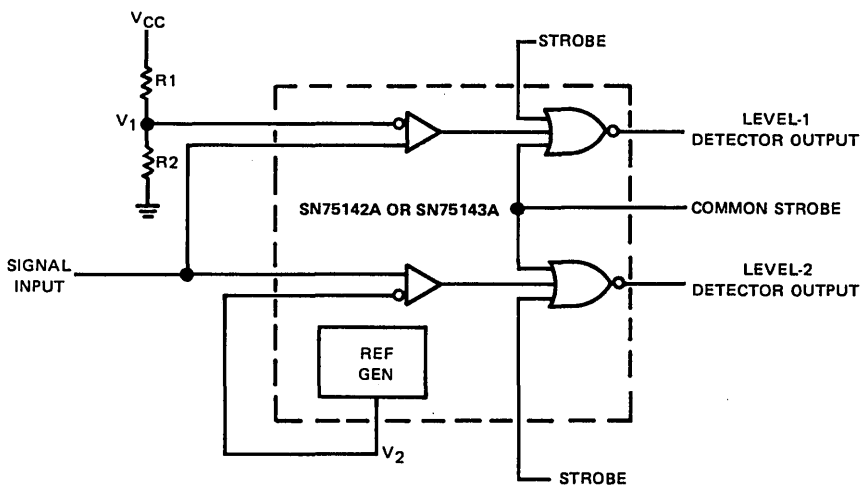

5

VOLTAGE TRANSFER CHARACTERISTICS WITH STROBES LOW

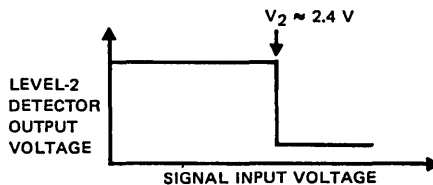
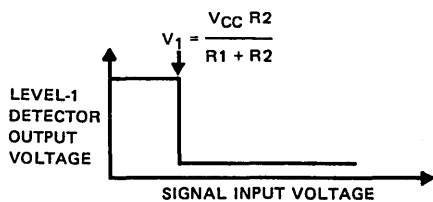

**TEXAS INSTRUMENTS**  
INCORPORATED

POST OFFICE BOX 225012 • DALLAS, TEXAS 75265



# INTERFACE CIRCUITS

# TYPE SN75150 DUAL LINE DRIVER

BULLETIN NO. DL-S 11428, JANUARY 1971 — REVISED JANUARY 1977

- Satisfies Requirements of EIA Standard RS-232-C
- Withstands Sustained Output Short-Circuit to any Low-Impedance Voltage between  $-25\text{ V}$  and  $25\text{ V}$
- $2\ \mu\text{s}$  Max Transition Time through the  $+3\text{ V}$  to  $-3\text{ V}$  Transition Region under Full  $2500\text{-pF}$  Load
- Inputs Compatible with Most TTL and DTL Families
- Common Strobe Input
- Inverting Output
- Slew Rate can be Controlled with an External Capacitor at the Output
- Standard Supply Voltages . . .  $\pm 12\text{ V}$

JG OR P DUAL-IN-LINE PACKAGE  
(TOP VIEW)

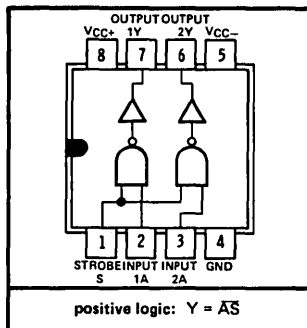

schematic (each line driver)

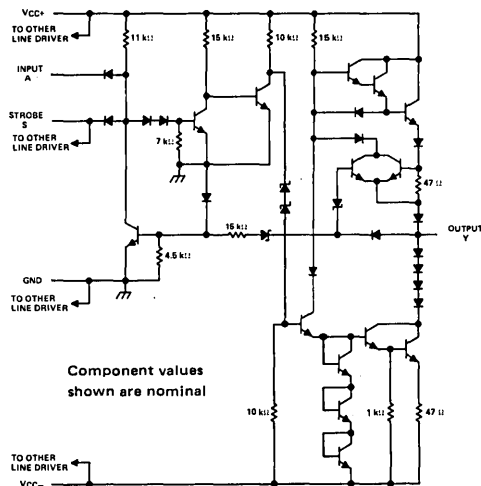

Component values shown are nominal

## description

The SN75150 is a monolithic dual line driver designed to satisfy the requirements of the standard interface between data terminal equipment and data communication equipment as defined by EIA Standard RS-232-C. A rate of 20,000 bits per second can be transmitted with a full  $2500\text{-pF}$  load. Other applications are in data-transmission systems using relatively short single lines, in level translators, and for driving MOS devices. The logic input is compatible with most TTL and DTL families. Operation is from  $+12\text{-volt}$  and  $-12\text{-volt}$  power supplies. The SN75150 is characterized for operation from  $0^\circ\text{C}$  to  $70^\circ\text{C}$ .

## absolute maximum ratings over operating free-air temperature range (unless otherwise noted)

Supply voltage $V_{CC+}$ (see Note 1)	. . . . .	$\pm 15\text{ V}$
Supply voltage $V_{CC-}$	. . . . .	$-15\text{ V}$
Input voltage	. . . . .	$\pm 15\text{ V}$
Applied output voltage	. . . . .	$\pm 25\text{ V}$
Continuous total dissipation at (or below) $25^\circ\text{C}$ free-air temperature (see Note 2): JG package	. . . . .	925 mW
	P package	1000 mW
Operating free-air temperature range	. . . . .	$0^\circ\text{C}$ to $70^\circ\text{C}$
Storage temperature range	. . . . .	$-65^\circ\text{C}$ to $150^\circ\text{C}$
Lead temperature 1/16 inch from case for 60 seconds: JG package	. . . . .	$300^\circ\text{C}$
Lead temperature 1/16 inch from case for 10 seconds: P package	. . . . .	$260^\circ\text{C}$

- NOTES: 1. Voltage values are with respect to network ground terminal.  
2. For operation above  $25^\circ\text{C}$  free-air temperature, refer to Dissipation Derating Curves in the Thermal Information section, which starts on page 2-1. In the JG package, SN75150 chips are glass-mounted.

TEXAS INSTRUMENTS  
INCORPORATED

POST OFFICE BOX 225012 • DALLAS, TEXAS 75265

# TYPE SN75150

## DUAL LINE DRIVER

REVISED JANUARY 1977

### recommended operating conditions

	MIN	NOM	MAX	UNIT
Supply voltage $V_{CC+}$	10.8	12	13.2	V
Supply voltage $V_{CC-}$	-10.8	-12	-13.2	V
Input voltage, $V_I$	0		5.5	V
Applied output voltage, $V_O$			±15	V
Operating free-air temperature, $T_A$	0		70	°C

### electrical characteristics over recommended operating free-air temperature range (unless otherwise noted)

PARAMETER	TEST FIGURE	TEST CONDITIONS	MIN	TYP†	MAX	UNIT	
$V_{IH}$ High-level input voltage	1		2			V	
$V_{IL}$ Low-level input voltage	2				0.8	V	
$V_{OH}$ High-level output voltage	2	$V_{CC+} = 10.8$ V, $V_{CC-} = -13.2$ V, $V_{IL} = 0.8$ V, $R_L = 3$ k $\Omega$ to 7 k $\Omega$	5	8		V	
$V_{OL}$ Low-level output voltage (See note 3)	1	$V_{CC+} = 10.8$ V, $V_{CC-} = -10.8$ V, $V_{IH} = 2$ V, $R_L = 3$ k $\Omega$ to 7 k $\Omega$		-8	-5	V	
$I_{IH}$ High-level input current	3	$V_{CC+} = 13.2$ V, $V_{CC-} = -13.2$ V, $V_I = 2.4$ V	Data input	1	10	$\mu$ A	
			Strobe input	2	20		
$I_{IL}$ Low-level input current	3	$V_{CC+} = 13.2$ V, $V_{CC-} = -13.2$ V, $V_I = 0.4$ V	Data input	-1	-1.6	mA	
			Strobe input	-2	-3.2		
$I_{OS}$ Short-circuit output current‡	4	$V_{CC+} = 13.2$ V, $V_{CC-} = -13.2$ V	$V_O = 25$ V	2	8	mA	
			$V_O = -25$ V		-3		-8
			$V_O = 0$ V, $V_I = 3$ V	10	15		30
$I_{CCH+}$ Supply current from $V_{CC+}$ , high-level output	5	$V_{CC+} = 13.2$ V, $V_I = 0$ V, $T_A = 25^\circ$ C	$V_{CC-} = -13.2$ V, $R_L = 3$ k $\Omega$	10	22	mA	
				-1	-10		
$I_{CCL+}$ Supply current from $V_{CC+}$ , low-level output	5	$V_{CC+} = 13.2$ V, $V_I = 3$ V, $T_A = 25^\circ$ C	$V_{CC-} = -13.2$ V, $R_L = 3$ k $\Omega$	8	17	mA	
				-9	-20		

NOTE 3: The algebraic convention, where the less positive (more negative) limit is designated as minimum, is used in this data sheet for logic levels only, e.g., when -5 V is the maximum, the typical value is a more negative voltage.

† All typical values are at  $V_{CC+} = 12$  V,  $V_{CC-} = -12$  V,  $T_A = 25^\circ$ C.

‡ Not more than one output should be shorted at a time.

### switching characteristics, $V_{CC+} = 12$ V, $V_{CC-} = -12$ V, $T_A = 25^\circ$ C

PARAMETER	TEST FIGURE	TEST CONDITIONS	MIN	TYP	MAX	UNIT
$t_{TLH}$ Transition time, low-to-high-level output	6	$C_L = 2500$ pF, $R_L = 3$ k $\Omega$ to 7 k $\Omega$	0.2	1.4	2	$\mu$ s
$t_{THL}$ Transition time, high-to-low-level output			0.2	1.5	2	$\mu$ s
$t_{TLH}$ Transition time, low-to-high-level output	6	$C_L = 15$ pF, $R_L = 7$ k $\Omega$		40		ns
$t_{THL}$ Transition time, high-to-low-level output				20		ns
$t_{PLH}$ Propagation delay time, low-to-high-level output	6	$C_L = 15$ pF, $R_L = 7$ k $\Omega$		60		ns
$t_{PHL}$ Propagation delay time, high-to-low-level output				45		ns



# TYPE SN75150 DUAL LINE DRIVER

## PARAMETER MEASUREMENT INFORMATION

d-c test circuits<sup>‡</sup>

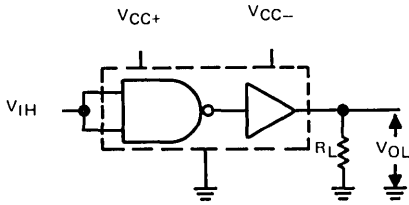
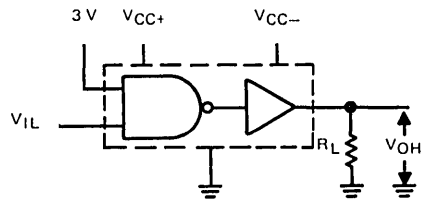
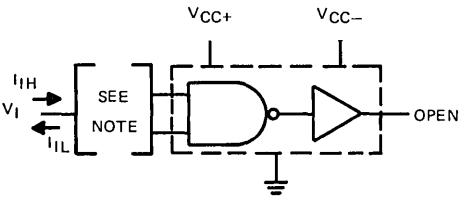

FIGURE 1— $V_{IH}$ ,  $V_{OL}$



Each input is tested separately.

FIGURE 2— $V_{IL}$ ,  $V_{OH}$



NOTE: When testing  $I_{IH}$ , the other input is at 3 V; when testing  $I_{IL}$ , the other input is open.

FIGURE 3— $I_{IH}$ ,  $I_{IL}$

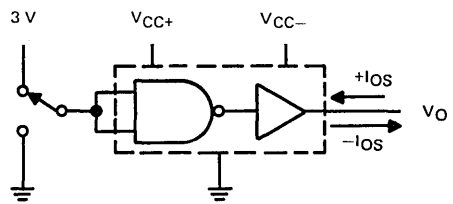

$I_{OS}$  is tested for both input conditions at each of the specified output conditions.

FIGURE 4— $I_{OS}$

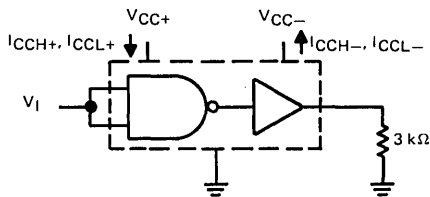

FIGURE 5— $I_{CCH+}$ ,  $I_{CCH-}$ ,  $I_{CCL+}$ ,  $I_{CCL-}$

<sup>‡</sup>Arrows indicate actual direction of current flow. Current into a terminal is a positive value.

# TYPE SN75150 DUAL LINE DRIVER

## PARAMETER MEASUREMENT INFORMATION

switching characteristics

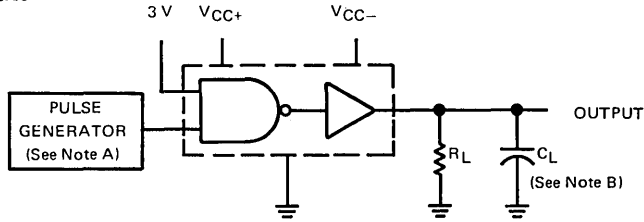

TEST CIRCUIT

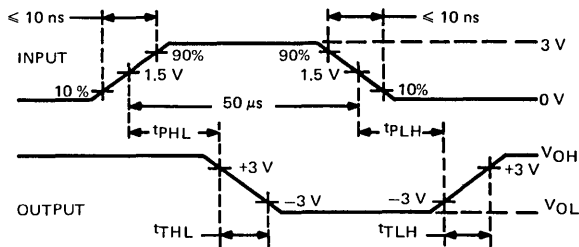

VOLTAGE WAVEFORMS

NOTES: A. The pulse generator has the following characteristics: duty cycle  $\leq 50\%$ ,  $Z_{out} \approx 50 \Omega$ .  
B.  $C_L$  includes probe and jig capacitance.

FIGURE 6—SWITCHING CHARACTERISTICS

### TYPICAL CHARACTERISTICS

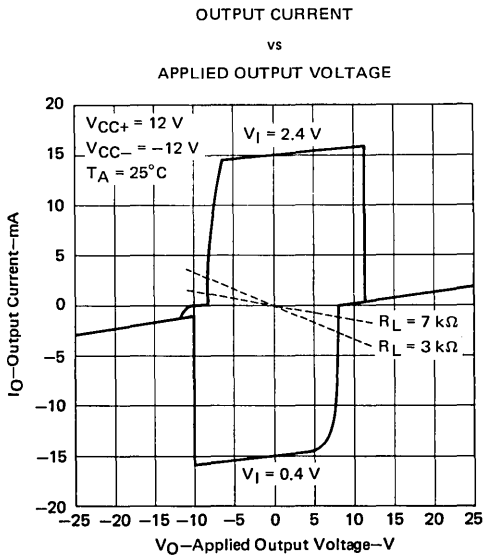

FIGURE 7

### TYPICAL APPLICATION DATA

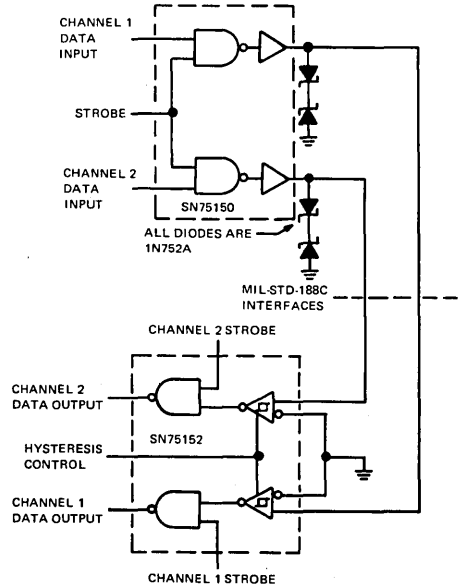

FIGURE 8—DUAL-CHANNEL SINGLE-ENDED INTERFACE CIRCUIT MEETING MIL-STD-188C, PARAGRAPH 7.2.

# INTERFACE CIRCUITS

# TYPES SN55151, SN55153, SN75151, SN75153 QUAD DIFFERENTIAL LINE DRIVERS WITH 3-STATE OUTPUTS

BULLETIN NO. DL-S 12629, DECEMBER 1978

- Meets EIA Standard RS-422A
- High-Impedance Output State for Party-Line Operation
- High Output Impedance in Power-Off Condition
- Low Input Current to Minimize Loading
- Single 5-V Supply
- 40-mA Sink- and Source-Current Capability
- High-Speed Schottky Circuitry
- Low Power Requirements

SN55151 . . . . J  
SN75151 . . . . J OR N  
DUAL-IN-LINE PACKAGE  
(TOP VIEW)

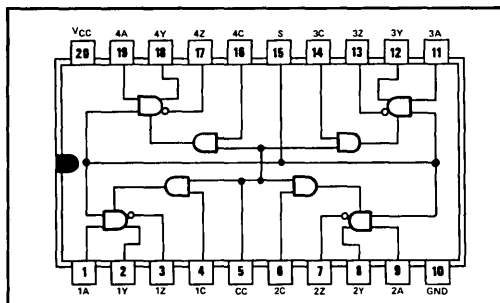

## description

These line drivers are designed to provide differential signals with high current capability on balanced lines. These circuits provide strobe and enable inputs to control all four drivers, and the '151 provides an additional enable input for each driver. The output circuits have active pull-up and pull-down and are capable of sinking or sourcing 40 milliamperes.

The '151 and '153 meet all requirements of RS-422A and Federal Standard 1020.

The SN55151 and SN55153 are characterized over the full military temperature range of  $-55^{\circ}\text{C}$  to  $125^{\circ}\text{C}$ . The SN75151 and SN75153 are characterized for operation from  $0^{\circ}\text{C}$  to  $70^{\circ}\text{C}$ .

SN55153 . . . . J  
SN75153 . . . . J OR N  
DUAL-IN-LINE PACKAGE  
(TOP VIEW)

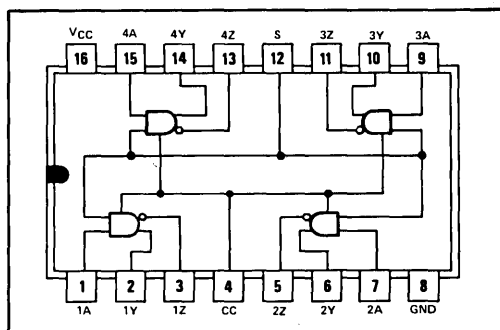

SN55151, SN75151  
FUNCTION TABLE

INPUTS				OUTPUTS	
ENABLE CC	ENABLE C	STROBE	DATA A	Y	Z
L	X	X	X	Z	Z
X	L	X	X	Z	Z
H	H	L	X	L	H
H	H	X	L	L	H
H	H	H	H	H	L

SN55153, SN75153  
FUNCTION TABLE

INPUTS			OUTPUTS	
ENABLE CC	STROBE	DATA A	Y	Z
L	X	X	Z	Z
H	L	X	L	H
H	X	L	L	H
H	H	H	H	L

Copyright © 1978 by Texas Instruments Incorporated

TEXAS INSTRUMENTS  
INCORPORATED

POST OFFICE BOX 225012 • DALLAS, TEXAS 75265

# TYPES SN55151, SN55153, SN75151, SN75153

## QUAD DIFFERENTIAL LINE DRIVERS WITH 3-STATE OUTPUTS

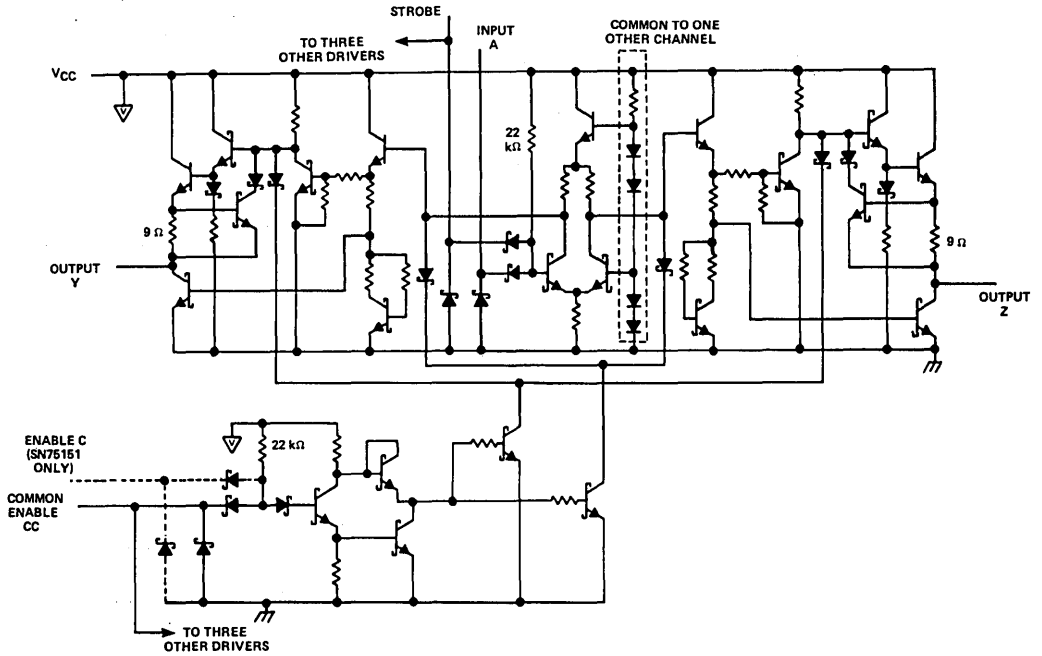

5

### absolute maximum ratings over operating free-air temperature range (unless otherwise noted)

Supply voltage, $V_{CC}$ (see Note 1)	7 V
Input voltage	5.5 V
Continuous total dissipation at (or below) 25°C free-air temperature (see Note 2)	1 W
Operating free-air temperature range: SN55151, SN55153	-55°C to 125°C
SN75151, SN75153	0°C to 70°C
Storage temperature range	-65°C to 150°C
Lead temperature 1/16 inch (1, 6 mm) from case for 60 seconds: J package	300°C
Lead temperature 1/16 inch (1, 6 mm) from case for 10 seconds: N package	260°C

- NOTES: 1. All voltage values, except differential output voltage  $V_{OD}$ , are with respect to network ground terminal.  
 2. For operation above 25°C free-air temperature, refer to the Dissipation Derating Table. In the J package, SN55151 and SN55153 chips are alloy-mounted; SN75151 and SN75153 chips are glass-mounted.

DISSIPATION DERATING TABLE

PACKAGE	POWER RATING	DERATING FACTOR	ABOVE $T_A$
J (Alloy-mounted)	1000 mW	11 mW/°C	59°C
J (Glass-mounted)	1000 mW	8.2 mW/°C	28°C
N	1000 mW	9.2 mW/°C	41°C

# TYPES SN55151, SN55153, SN75151, SN75153

## QUAD DIFFERENTIAL LINE DRIVERS WITH 3-STATE OUTPUTS

### recommended operating conditions

	SN55'			SN75'			UNIT
	MIN	NOM	MAX	MIN	NOM	MAX	
Supply voltage, $V_{CC}$	4.5	5	5.5	4.75	5	5.25	V
Common-mode output voltage	-0.25		6	-0.25		6	V
High-level output current, $I_{OH}$			-40			-40	mA
Low-level output current, $I_{OL}$			40			40	mA
Operating free-air temperature, $T_A$	-55	125		0		70	°C

### electrical characteristics over operating free-air temperature range (unless otherwise noted)

PARAMETER	TEST CONDITIONS†		SN55'		SN75'		UNIT		
			MIN	TYP‡	MAX	MIN		TYP‡	MAX
$V_{IH}$ High-level input voltage			2		2		V		
$V_{IL}$ Low-level input voltage			0.7		0.8		V		
$V_{IK}$ Input clamp voltage	$V_{CC} = \text{MIN},$ $I_I = -12 \text{ mA}$	CC, S	-2		-2		V		
		All others	-0.9	-1.5	-0.9	-1.5	V		
$V_{OH}$ High-level output voltage	$V_{CC} = \text{MIN},$ $V_{IL} = \text{MAX},$ $V_{IH} = 2 \text{ V}$	$I_{OH} = -20 \text{ mA}$	2.4		2.5		V		
		$I_{OH} = -40 \text{ mA}$	2		2.4		V		
$V_{OL}$ Low-level output voltage	$V_{CC} = \text{MIN},$ $V_{IH} = 2 \text{ V},$ $V_{CC} = \text{MAX},$ $I_O = 0$	$V_{IL} = \text{MAX},$ $I_{OL} = 40 \text{ mA}$	0.5		0.5		V		
$V_{OD1}^{\dagger}$ Differential output voltage	$V_{CC} = \text{MAX},$ $I_O = 0$		3.4 $2V_{OD2}$		3.4 $2V_{OD2}$		V		
$V_{OD2}^{\dagger}$ Differential output voltage	$V_{CC} = \text{MIN}$	$R_L = 100 \Omega,$ See Figure 1	2	2.8	2	2.8	V		
$\Delta V_{OD}^{\dagger}$ Change in magnitude of differential output voltage §	$V_{CC} = \text{MIN}$		$\pm 0.01$	$\pm 0.4$	$\pm 0.01$	$\pm 0.4$	V		
$V_{OC}^{\dagger}$ Common-mode output voltage ¶	$V_{CC} = \text{MAX}$		1.9	3	1.8	3	V		
	$V_{CC} = \text{MIN}$		1.5	3	1.6	3	V		
$\Delta V_{OC}^{\dagger}$ Change in magnitude of common-mode output voltage §	$V_{CC} = \text{MIN or MAX}$		$\pm 0.02$	$\pm 0.4$	$\pm 0.02$	$\pm 0.4$	V		
$I_{OZ}$ Off-state (high-impedance-state) output current	$V_{CC} = \text{MAX},$ Enable at 0.8 V	$V_O = 0.5 \text{ V}$	-150		-20		$\mu\text{A}$		
		$V_O = 2.5 \text{ V}$	80		20				
		$V_O = V_{CC}$	150		20				
$I_O$ Output current with power off	$V_{CC} = 0$	$V_O = 6 \text{ V}$	0.1	100	0.1	100	$\mu\text{A}$		
		$V_O = -0.25 \text{ V}$	-0.1	-100	-0.1	-100			
		$V_O = -0.25 \text{ V to } 6 \text{ V}$	$\pm 100$		$\pm 100$				
$I_I$ Input current at maximum input voltage	$V_{CC} = \text{MAX},$	$V_I = 5.5 \text{ V}$	0.1		0.1		mA		
$I_{IH}$ High-level input current	$V_{CC} = \text{MAX},$ $V_I = 2.4 \text{ V}$	C ('151), A	20		20		$\mu\text{A}$		
		CC, S	80		80				
$I_{IL}$ Low-level input current	$V_{CC} = \text{MAX},$ $V_I = 0.4 \text{ V}$	C ('151), A	-0.36		-0.36		mA		
		CC, S	-1.6		-1.6				
$I_{OS}$ Short-circuit output current#	$V_{CC} = \text{MAX}$		-50	-90	-150	-50	-90	-150	mA
$I_{CC}$ Supply current (both drivers)	$V_{CC} = \text{MAX},$ No load	outputs disabled	30		60		mA		
		outputs enabled	60		80				

† For conditions shown as MIN or MAX, use the appropriate value specified under recommended operating conditions.

‡ All typical values are at  $T_A = 25^\circ\text{C}$  and  $V_{CC} = 5 \text{ V}$  except for  $V_{OC}$ , for which  $V_{CC}$  is as stated under test conditions.

§  $\Delta V_{OD}^{\dagger}$  and  $\Delta V_{OC}^{\dagger}$  are the changes in magnitudes of  $V_{OD}$  and  $V_{OC}$ , respectively, that occur when the input is changed from a high level to a low level.

¶ In EIA Standard RS-422A,  $V_{OC}$ , which is the average of the two output voltages with respect to ground, is called output offset voltage,  $V_{OS}$ .

# Only one output should be shorted at a time, and duration of the short-circuit should not exceed one second.

# TYPES SN55151, SN55153, SN75151, SN75153

## QUAD DIFFERENTIAL LINE DRIVERS WITH 3-STATE OUTPUTS

switching characteristics,  $V_{CC} = 5\text{ V}$ ,  $T_A = 25^\circ\text{C}$

PARAMETER	TEST CONDITIONS	MIN	TYP	MAX	UNIT
$t_{PLH}$ Propagation delay time, low-to-high-level output	$C_L = 30\text{ pF}$ , $R_L = 100\ \Omega$ , See Figure 2, Termination A		15	30	ns
$t_{PHL}$ Propagation delay time, high-to-low-level output			15	30	ns
$t_{PLH}$ Propagation delay time, low-to-high-level output	$C_L = 30\text{ pF}$ , See Figure 2, Termination B		13	25	ns
$t_{PHL}$ Propagation delay time, high-to-low-level output			13	25	ns
$t_{TLH}$ Transition time, low-to-high-level output	$C_L = 30\text{ pF}$ , $R_L = 100\ \Omega$ , See Figure 2, Termination A		12	20	ns
$t_{THL}$ Transition time, high-to-low-level output			12	20	ns
$t_{PZL}$ Output enable time to low level	$C_L = 30\text{ pF}$ , $R_L = 60\ \Omega$ , See Figure 3		18	35	ns
$t_{PHZ}$ Output disable time from high level	$C_L = 30\text{ pF}$ , $R_L = 60\ \Omega$ , See Figure 3		19	30	ns
$t_{PLZ}$ Output disable time from low level	$C_L = 30\text{ pF}$ , $R_L = 111\ \Omega$ , See Figure 4		13	30	ns
Overshoot factor	$R_L = 100\ \Omega$ , See Figure 2, Termination C		10		%

### PARAMETER MEASUREMENT INFORMATION

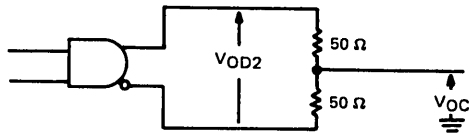
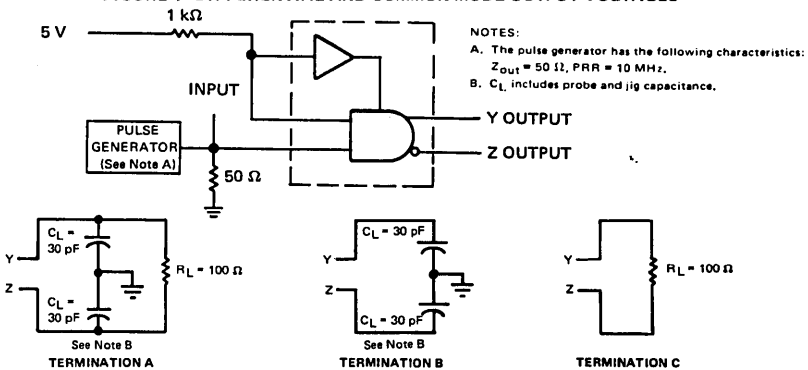
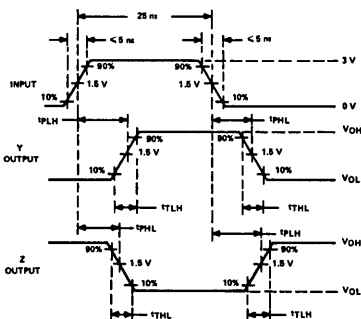

FIGURE 1—DIFFERENTIAL AND COMMON-MODE OUTPUT VOLTAGES



### TEST CIRCUITS



### VOLTAGE WAVEFORMS

FIGURE 2— $t_{PLH}$ ,  $t_{PHL}$ ,  $t_{TLH}$ ,  $t_{THL}$ , AND OVERSHOOT FACTOR

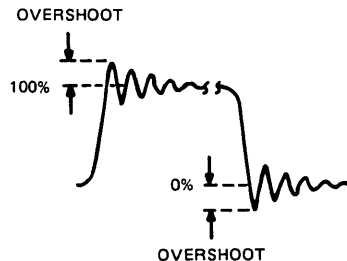

# TYPES SN55151, SN55153, SN75151, SN75153 QUAD DIFFERENTIAL LINE DRIVERS WITH 3-STATE OUTPUTS

## PARAMETER MEASUREMENT INFORMATION

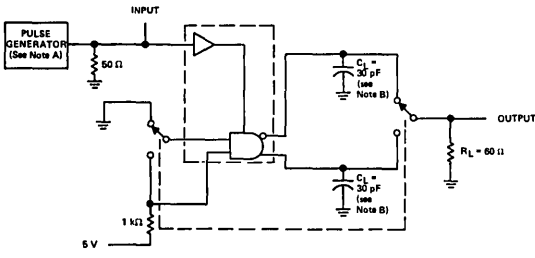

TEST CIRCUIT

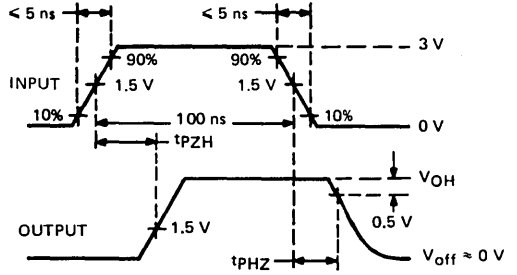

VOLTAGE WAVEFORMS

FIGURE 3— $t_{pZH}$  AND  $t_{PHZ}$

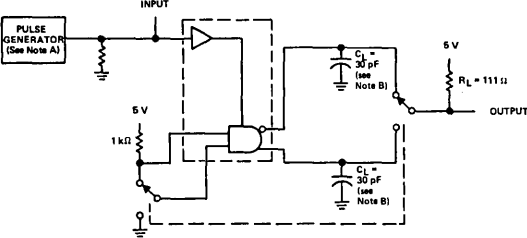

TEST CIRCUIT

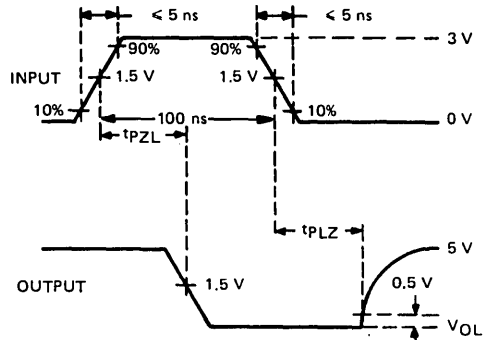

VOLTAGE WAVEFORMS

FIGURE 4— $t_{pZL}$  AND  $t_{PLZ}$

NOTES: A. The pulse generators have the following characteristics:  $Z_{out} = 50\ \Omega$ ,  $PRR = 500\text{ kHz}$   
B.  $C_L$  includes probe and jig capacitance.

## TYPICAL CHARACTERISTICS

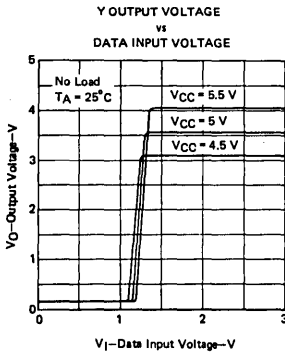

FIGURE 5

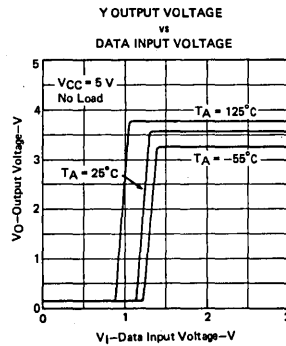

FIGURE 6

TEXAS INSTRUMENTS  
INCORPORATED

POST OFFICE BOX 225012 • DALLAS, TEXAS 75265

# TYPES SN55151, SN55153, SN75151, SN75153

## QUAD DIFFERENTIAL LINE DRIVERS WITH 3-STATE OUTPUTS

### TYPICAL CHARACTERISTICS†

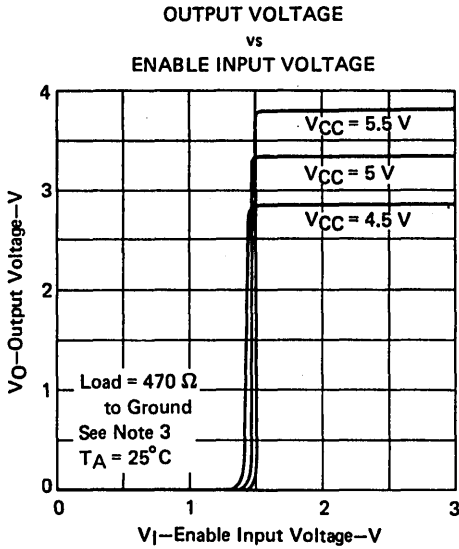

FIGURE 7

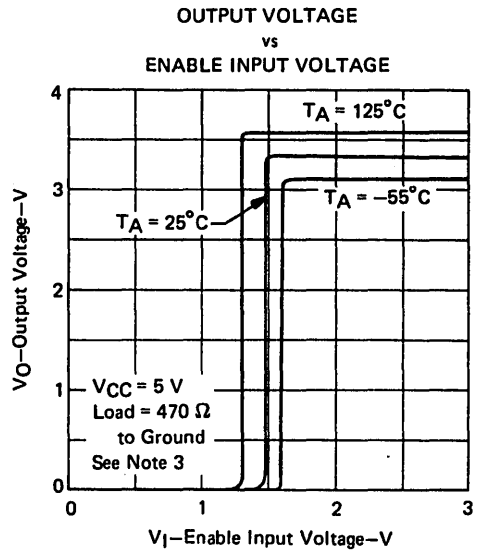

FIGURE 8

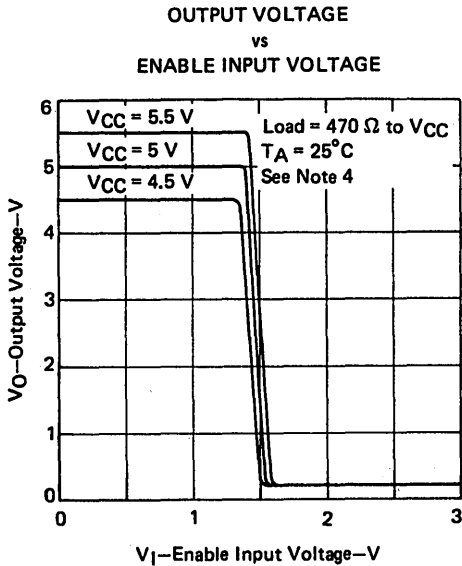

FIGURE 9

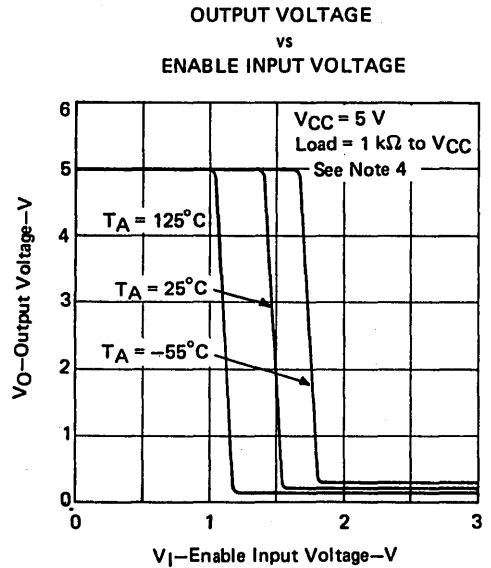

FIGURE 10

- NOTES: 3. The A input is connected to V<sub>CC</sub> during the testing of the Y outputs and to ground during testing of the Z outputs.  
4. The A input is connected to ground during the testing of the Y outputs and to V<sub>CC</sub> during the testing of the Z inputs.

† Data for temperatures below 0°C and above 70°C are applicable to SN55151 and SN55153 circuits only.



# TYPES SN55151, SN55153, SN75151, SN75153 QUAD DIFFERENTIAL LINE DRIVERS WITH 3-STATE OUTPUTS

## TYPICAL CHARACTERISTICS†

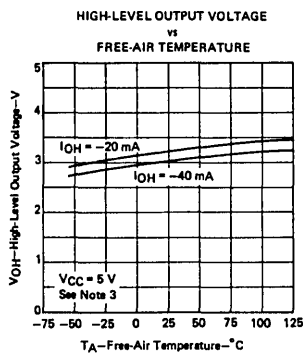

FIGURE 11

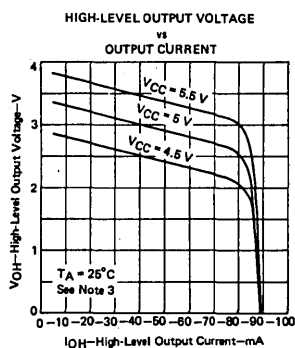

FIGURE 12

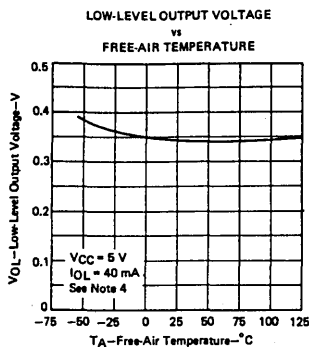

FIGURE 13

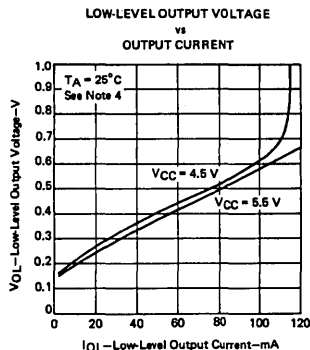

FIGURE 14

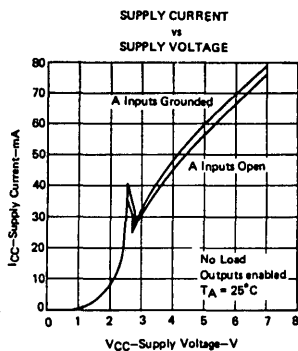

FIGURE 15

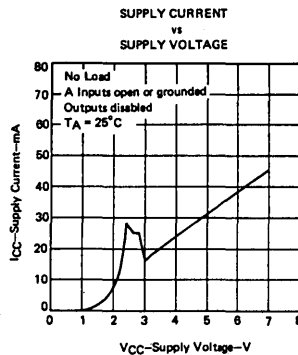

FIGURE 16

- NOTES: 3. The A input is connected to  $V_{CC}$  during the testing of the Y outputs and to ground during testing of the Z outputs.  
4. The A input is connected to ground during the testing of the Y outputs and to  $V_{CC}$  during the testing of the Z outputs.  
† Data for temperature below  $0^{\circ}\text{C}$  and above  $70^{\circ}\text{C}$  are applicable to SN55151 and SN55153 circuits only.

5

- Meets Specifications of EIA RS-232-C or MIL-STD-188C†
- Dual Differential Receiver with Independent Strobes
- Common-Mode Input Voltage Range . . . ±25 V
- Differential Input Capability with One Input Grounded . . . ±25 V
- Continuously Adjustable Hysteresis with External Resistors
- Standard Supply Voltages . . . +12 V and -12 V
- Input Hysteresis (Double Thresholds) Remain Approximately Fixed for Power Supply and/or Temperature Variations

5

JORN  
DUAL-IN-LINE PACKAGE (TOP VIEW)

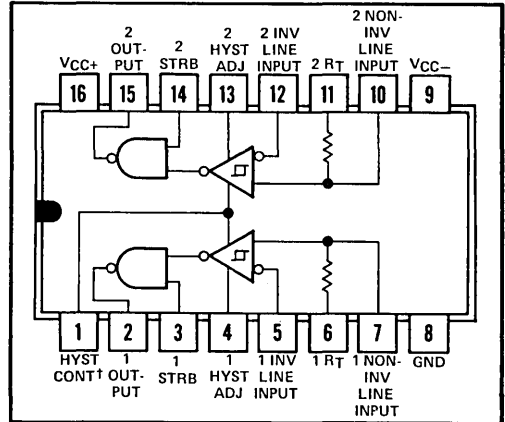

†To meet the specifications of EIA Standard RS-232-C, connect Hysteresis Control (Pin 1) to  $V_{CC-}$  (Pin 9). Also, connect pin 6 to pin 5 and pin 11 to pin 12. To meet the specifications of MIL-STD-188, leave Hysteresis Control (pin 1) and termination resistors (pin 6 and 11) open.

## description

The SN75152 is a dual differential line receiver designed to meet the requirements of EIA standard RS-232-C or MIL-STD-188 interfaces. A single control (pin 1) sets the input hysteresis for the required operation. An added feature is the capability of adjusting the hysteresis to any voltage between ±0.3 volt typical and ±5 volts typical by means of the hysteresis adjust terminals (pin 4 and 13) making the SN75152 useful for a wide variety of line receiver and Schmitt trigger applications. The large common-mode input voltage range and differential input voltage (±25 volts) give the circuit added versatility. The SN75152 is designed for operation from standard ±12-volt supplies with ±10% variation. Each receiver has an output strobe that is TTL compatible.

FUNCTION TABLE  
(EACH RECEIVER)

LINE INPUT	STROBE	OUTPUT
H	H	H
L	H	L
X	L	H

### Definition of logic levels:

For the strobe: H (high) is any voltage between  $V_{IH}$  min and  $V_{CC}$ .

L (low) is any voltage between ground and  $V_{IL}$  max.

For the line input: H (high) is any differential input voltage ( $V_{ID}$ )‡ more positive than  $V_{T-}$ , once the level of  $V_{T+}$  has been reached.

L (low) is any differential input voltage ( $V_{ID}$ )‡ more negative than  $V_{T+}$ , once the level of  $V_{T-}$  has been reached.

X (irrelevant) is any input voltage permitted by maximum ratings.

‡Differential input voltages ( $V_T$  and  $V_{ID}$ ) are at the noninverting input terminal with respect to the inverting input terminal.

**TYPE SN75152  
DUAL LINE RECEIVER**

schematic (each receiver)

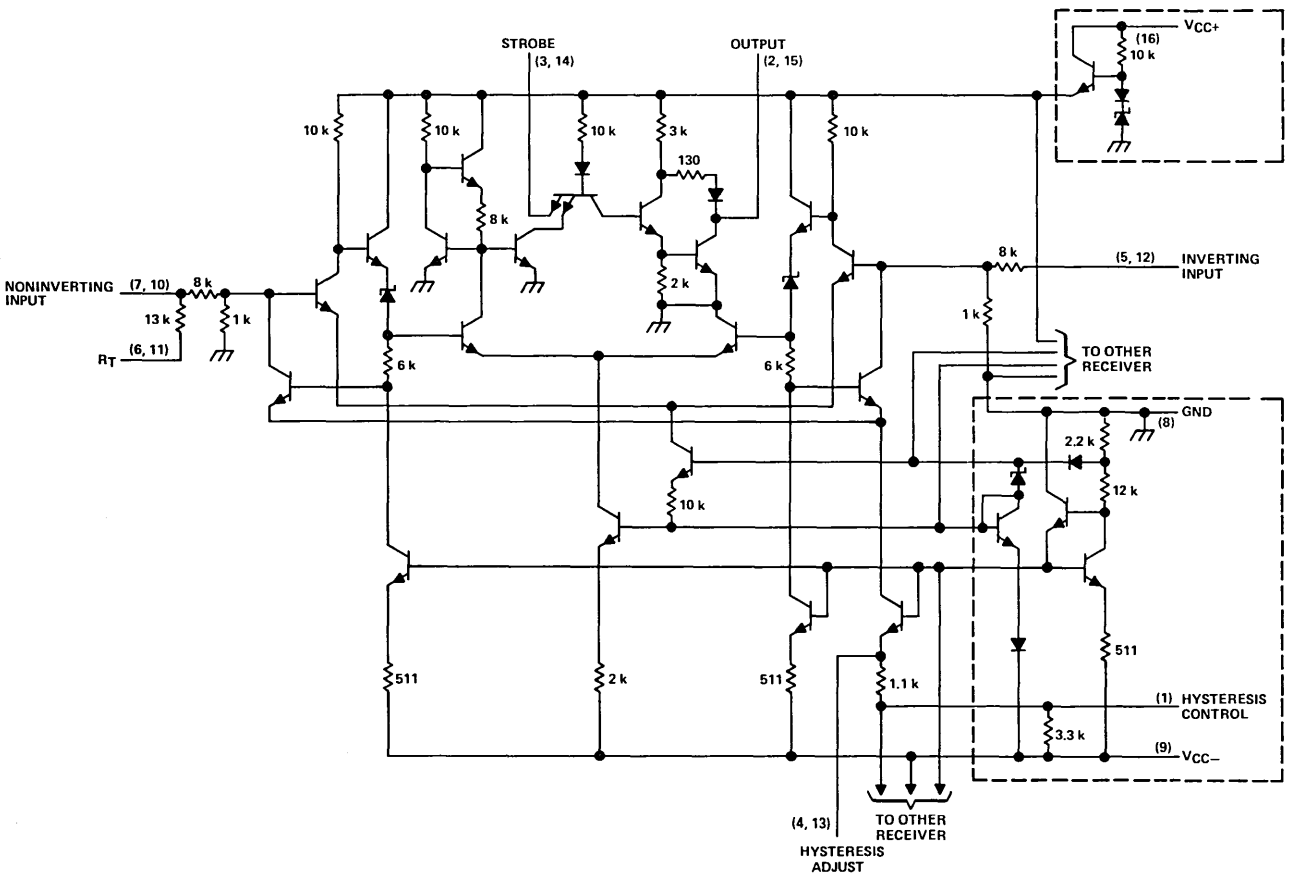

Portions of circuit within dashed lines are common to both receivers.  
Resistor values shown are nominal and in ohms.

# TYPE SN75152

## DUAL LINE RECEIVER

absolute maximum ratings over operating free-air temperature range (unless otherwise noted)

Supply voltage $V_{CC+}$ (see Note 1)	15 V
Supply voltage $V_{CC-}$ (see Note 1)	-15 V
Voltage at any line input with respect to other line input, ground, or $R_T$ terminal	$\pm 25$ V
$R_T$ terminal voltage (see Note 1)	$\pm 25$ V
Strobe input voltage (see Note 1)	5.5 V
Operating free-air temperature range	0°C to 70°C
Storage temperature range	-65°C to 150°C
Lead temperature 1/16 inch from case for 60 seconds: J package	300°C
Lead temperature 1/16 inch from case for 10 seconds: N package	260°C

NOTE 1: These voltage values are with respect to network ground terminal.

electrical characteristics over operating free-air temperature range,  $V_{CC+} = 12 \text{ V} \pm 10\%$ ,  $V_{CC-} = -12 \text{ V} \pm 10\%$  (unless otherwise noted)

PARAMETER		TEST FIGURE	TEST CONDITIONS†	MIN TYP‡ MAX (SEE NOTE 2)			UNIT	
$V_{T+}$	Positive-going threshold voltage	1	MIL-STD-188 Conditions	0.1	0.3	0.5	V	
$V_{T-}$	Negative-going threshold voltage			-0.5	-0.3	-0.1		
$V_{T+}$	Positive-going threshold voltage	2	EIA RS-232-C Conditions	1.5	2.2	3	V	
$V_{T-}$	Negative-going threshold voltage			-3	-2.2	-1.5		
$V_{IH}$	High-level input voltage at strobe	1		2			V	
$V_{IL}$	Low-level input voltage at strobe	1		0.8			V	
$V_{OH}$	High-level output voltage	1 and 2	$V_{ID} = V_{T+} \text{ max,}$ $I_{OH} = -500 \mu\text{A}$	$V_{I(\text{strobe})} = 2 \text{ V,}$	3	4.1	6	V
		1 and 2	$V_{ID} = V_{T-} \text{ min,}$ $I_{OH} = -500 \mu\text{A}$	$V_{I(\text{strobe})} = 0.8 \text{ V,}$	3	4.1	6	
$V_{OL}$	Low level output voltage	1 and 2	$V_{ID} = V_{T-} \text{ min,}$ $I_{OL} = 6.4 \text{ mA}$	$V_{I(\text{strobe})} = 2 \text{ V,}$	0	0.15	0.4	V
$I_I$	Input current into strobe at maximum strobe voltage	3	$V_{I(\text{strobe})} = 5.5 \text{ V}$		0.1	1	mA	
$I_{IH}$	High-level strobe current	3	$V_{I(\text{strobe})} = 2.4 \text{ V}$		30	80	$\mu\text{A}$	
$I_{IL}$	Low-level strobe current	3	$V_{I(\text{strobe})} = 0.4 \text{ V}$		-0.5	-1.5	mA	
$r_i$	Input resistance	MIL-STD-188	4	$ V_{ID}  = 0 \text{ V to } 25 \text{ V,}$ $R_T \text{ open}$	6	9	$\text{k}\Omega$	
		EIA RS-232-C	4	$ V_{ID}  = 3 \text{ V to } 25 \text{ V,}$ $R_T \text{ connected to inverting line input}$	3	5		7
$V_{I(\text{open})}$	Open-circuit input voltage	5			+1	$\pm 2$	V	
$I_{OS}$	Short-circuit output current	6	$V_{ID} = 3 \text{ V}$		-1.9	-4	mA	
$I_{CC+}$	Supply current from $V_{CC+}$	1	$V_{ID} = -3 \text{ V,}$	$V_{I(\text{strobe})} = 2.4 \text{ V}$	10	16	mA	
$I_{CC-}$	Supply current from $V_{CC-}$	1	$V_{ID} = -3 \text{ V,}$	$V_{I(\text{strobe})} = 2.4 \text{ V}$	-7	-13	mA	

† Differential input voltages ( $V_T$  and  $V_{ID}$ ) are at the noninverting line input terminal with respect to the inverting line input terminal.

‡ Typical values are at  $V_{CC+} = 12 \text{ V, } V_{CC-} = -12 \text{ V, } T_A = 25^\circ\text{C}$ .

NOTE 2: The algebraic convention, where the less-positive (more-negative) limit is designated as minimum, is used in this data sheet for threshold levels only, e.g., when -0.1 V is the maximum, the minimum limit is a more-negative voltage.

switching characteristics,  $V_{CC+} = 12 \text{ V, } V_{CC-} = -12 \text{ V, } T_A = 25^\circ\text{C}$

PARAMETER		TEST FIGURE	TEST CONDITIONS	MIN	TYP	MAX	UNIT
$t_{PLH}$	Propagation delay time, low-to-high-level output	7	$C_L = 15 \text{ pF}$	40			ns
$t_{PHL}$	Propagation delay time, high-to-low-level output			60			ns

# TYPE SN75152 DUAL LINE RECEIVER

## PARAMETER MEASUREMENT INFORMATION

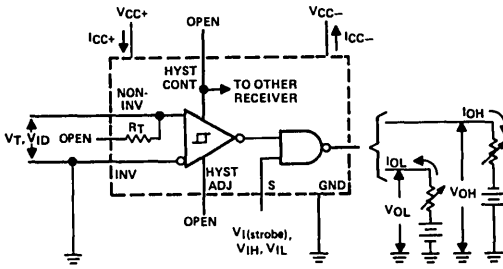

NOTE: Output is open for testing  $I_{CC+}$  and  $I_{CC-}$ .

FIGURE 1—MIL-STD-188 CONDITION

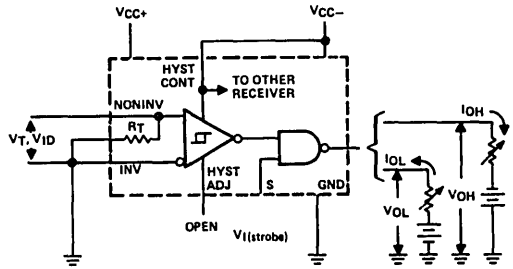

FIGURE 2—EIA RS-232-C CONDITION

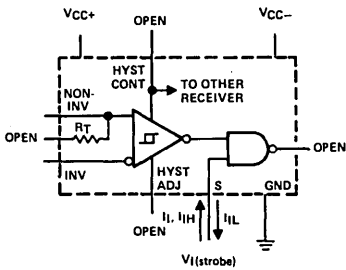

FIGURE 3

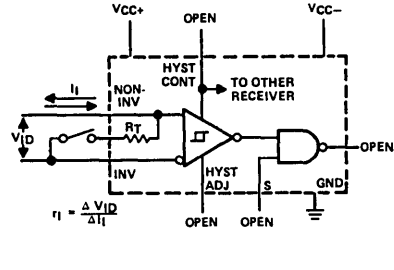

FIGURE 4

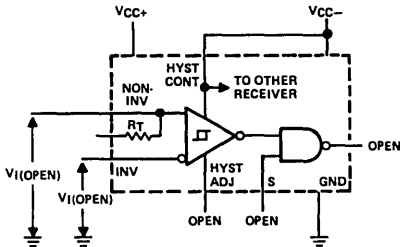

FIGURE 5

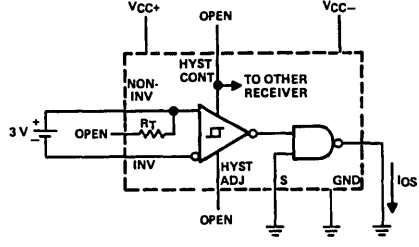
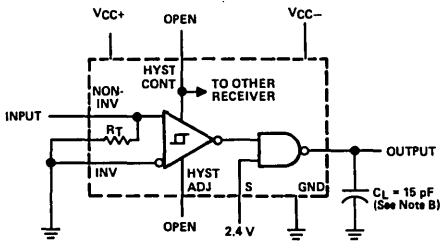
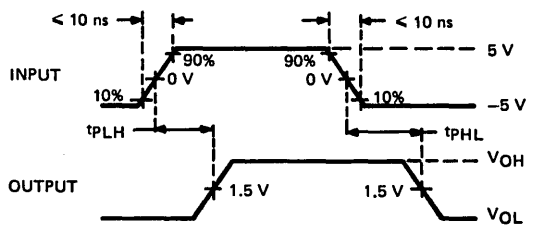

FIGURE 6



TEST CIRCUIT



VOLTAGE WAVEFORMS

NOTES: A. The input pulse is supplied by a generator having the following characteristics:  $t_w = 500\text{ ns}$ ,  $\text{PRR} = 1\text{ MHz}$ ,  $Z_{out} \approx 50\ \Omega$ .  
B.  $C_L$  includes probe and jig capacitance.

FIGURE 7—PROPAGATION DELAY TIMES

# TYPE SN75152 DUAL LINE RECEIVER

## TYPICAL CHARACTERISTICS

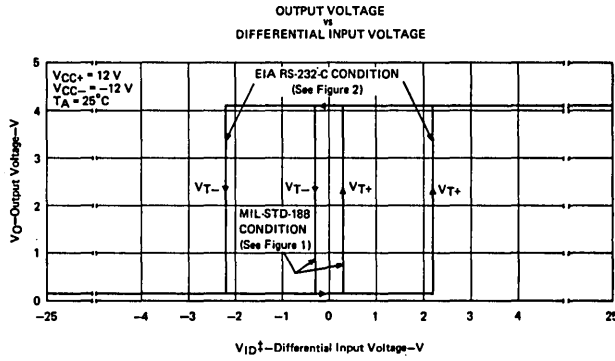

FIGURE 8

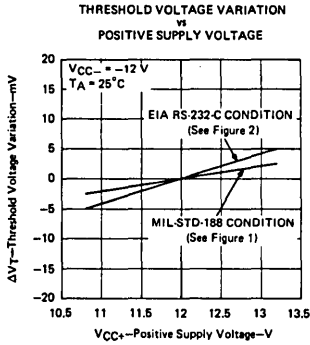

FIGURE 9

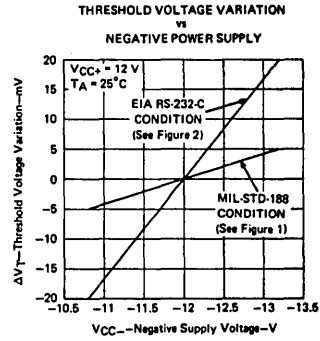

FIGURE 10

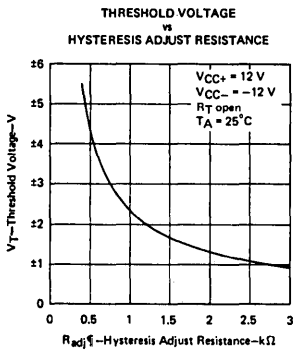

FIGURE 11

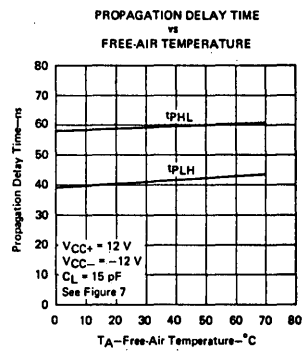

FIGURE 12

‡Differential input voltages ( $V_T$  and  $V_{ID}$ ) are at the noninverting input terminal with respect to the inverting input terminal.  
 ¶ $R_{adj}$  is connected between Hysteresis Adjust terminal and  $V_{CC-}$ .

# TYPE SN75152 DUAL LINE RECEIVER

## TYPICAL APPLICATIONS

Some typical applications of the SN75152 are as follows:

- MIL-STD-188 Interface Receiver
- EIA RS-232-C Interface Receiver
- Single-Ended Line Receiver
- Differential Line Receiver
- High-Noise-Immunity Line Receiver
- Schmitt Trigger
- High-Voltage-Logic-to-TTL Translator
- MOS to TTL Converter
- Pulse Generator
- Threshold detector
- Pulse Shaper

5

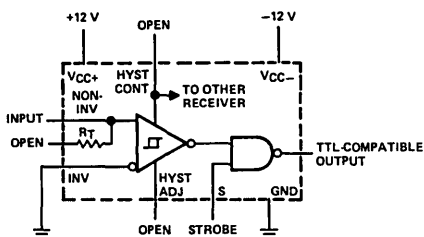
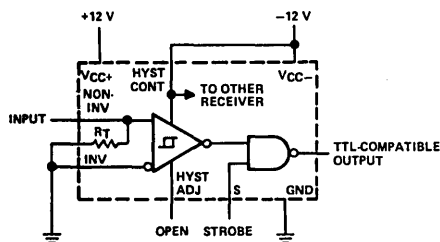
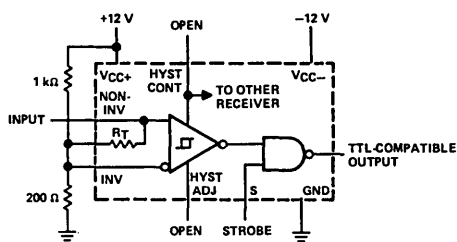

FIGURE 13—MIL-STD-188 SINGLE-ENDED LINE RECEIVER



NORMAL OPERATION



FAIL-SAFE OPERATION

FIGURE 14—EIA RS-232-C SINGLE-ENDED RECEIVER

# TYPE SN75152 DUAL LINE RECEIVER

## TYPICAL APPLICATIONS

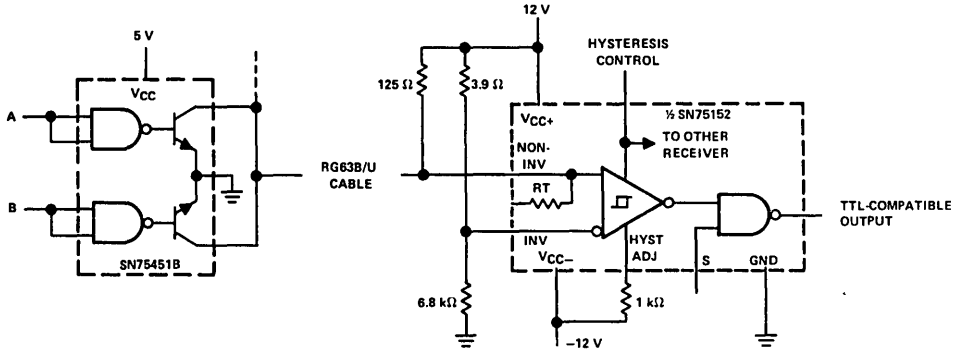
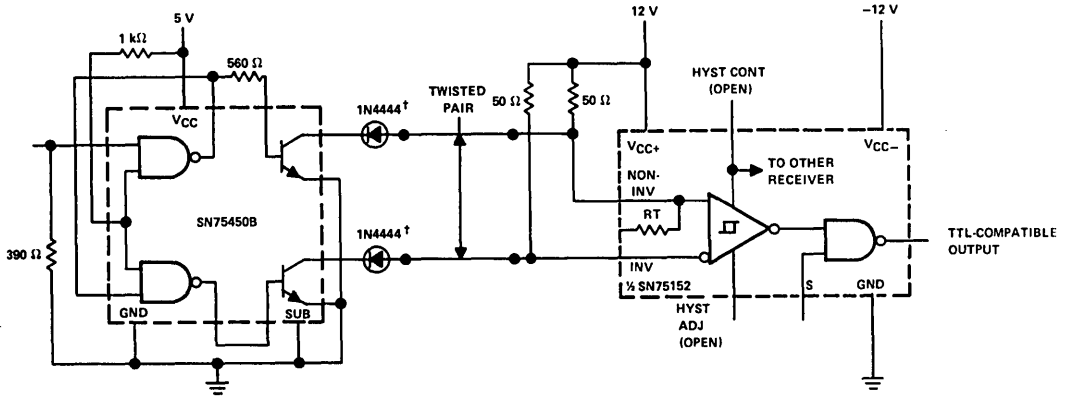

FIGURE 15—SINGLE-ENDED TRANSMITTER WITH DRIVER "OR" CAPABILITY AND RECEIVER WITH ADJUSTABLE NOISE IMMUNITY



Frequency to 0.5 MHz  
Common-Mode Voltage . . . -12 V to +10 V

†The 1N4444 diodes are required only for negative common-mode protection at the driver outputs.

FIGURE 16—BALANCED LINE OPERATION WITH HIGH COMMON-MODE-VOLTAGE CAPABILITY



# INTERFACE CIRCUITS

# TYPE SN75154 QUADRUPLE LINE RECEIVER

BULLETIN NO. DL-S 11389, NOVEMBER 1970 — REVISED JANUARY 1977

- Satisfies Requirements of EIA Standard RS-232-C
- Input Resistance . . . 3 kΩ to 7 kΩ over Full RS-232-C Voltage Range
- Input Threshold Adjustable to Meet "Fail-Safe" Requirements Without Using External Components
- Built-In Hysteresis for Increased Noise Immunity
- Inverting Output Compatible with DTL or TTL
- Output with Active Pull-Up for Symmetrical Switching Speeds
- Standard Supply Voltages . . . 5 V or 12 V

## description

The SN75154 is a monolithic quadruple line receiver designed to satisfy the requirements of the standard interface between data terminal equipment and data communication equipment as defined by EIA Standard RS-232C. Other applications are for relatively short, single-line, point-to-point data transmission and for level translators. Operation is normally from a single five-volt supply; however, a built-in option allows operation from a 12-volt supply without the use of additional components. The output is compatible with most TTL and DTL circuits when either supply voltage is used.

In normal operation, the threshold-control terminals are connected to the V<sub>CC1</sub> terminal, pin 15, even if power is being supplied via the alternate V<sub>CC2</sub> terminal, pin 16. This provides a wide hysteresis loop which is the difference between the positive-going and negative-going threshold voltages. See typical characteristics. In this mode of operation, if the input voltage goes to zero, the output voltage will remain at the low or high level as determined by the previous input.

For fail-safe operation, the threshold-control terminals are open. This reduces the hysteresis loop by causing the negative-going threshold voltage to be above zero. The positive-going threshold voltage remains above zero as it is unaffected by the disposition of the threshold terminals. In the fail-safe mode, if the input voltage goes to zero or an open-circuit condition, the output will go to the high level regardless of the previous input condition.

## absolute maximum ratings over operating free-air temperature range (unless otherwise noted)

Normal supply voltage (pin 15), V <sub>CC1</sub> (see Note 1)	7 V
Alternate supply voltage (pin 16), V <sub>CC2</sub>	14 V
Input voltage	±25 V
Continuous total dissipation at (or below) 25°C free-air temperature (see Note 2): J package	1025 mW
N package	1150 mW
Operating free-air temperature range	0°C to 70°C
Storage temperature range	-65°C to 150°C
Lead temperature 1/16 inch from case for 60 seconds: J package	300°C
N package	260°C

NOTES: 1. Voltage values are with respect to the network ground terminal.

2. For operation above 25°C free-air temperature, refer to Dissipation Derating Curves in the Thermal Information Section, which starts on page 2-1. In the J package, SN75154 chips are glass-mounted.

## recommended operating conditions

	MIN	NOM	MAX	UNIT
Normal supply voltage (pin 15), V <sub>CC1</sub>	4.5	5	5.5	V
Alternate supply voltage (pin 16), V <sub>CC2</sub>	10.8	12	13.2	V
Input voltage			±15	V
Normalized fan-out from each output, N			10	
Operating free-air temperature, T <sub>A</sub>	0		70	°C

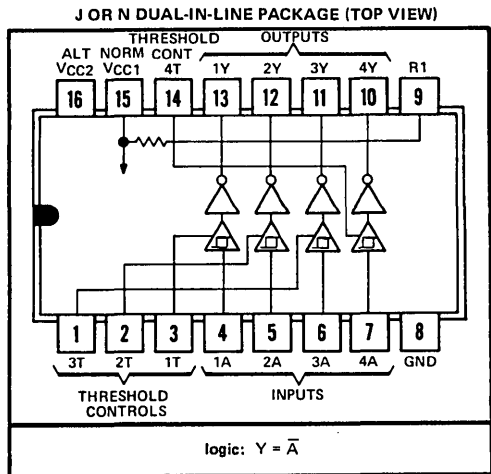

# TYPE SN75154 QUADRUPLE LINE RECEIVER

REVISED JANUARY 1977

electrical characteristics over recommended operating free-air temperature range (unless otherwise noted)

PARAMETER		TEST FIGURE	TEST CONDITIONS	MIN TYP <sup>‡</sup> MAX (SEE NOTE 3)	UNIT
V <sub>IH</sub>	High-level input voltage	1		3	V
V <sub>IL</sub>	Low-level input voltage	1		-3	V
V <sub>T+</sub>	Positive-going threshold voltage	Normal operation		0.8 2.2 3	V
		Fail-safe operation		0.8 2.2 3	
V <sub>T-</sub>	Negative-going threshold voltage	Normal operation		-3 -1.1 0	V
		Fail-safe operation		0.8 1.4 3	
V <sub>T+</sub> -V <sub>T-</sub>	Hysteresis	Normal operation		0.8 3.3 6	V
		Fail-safe operation		0 0.8 2.2	
V <sub>OH</sub>	High-level output voltage	1	I <sub>OH</sub> = -400 μA	2.4 3.5	V
V <sub>OL</sub>	Low-level output voltage	1	I <sub>OL</sub> = 16 mA	0.23 0.4	V
r <sub>i</sub>	Input resistance	2	ΔV <sub>I</sub> = -25 V to -14 V	3 5 7	kΩ
			ΔV <sub>I</sub> = -14 V to -3 V	3 5 7	
			ΔV <sub>I</sub> = -3 V to 3 V	3 6 8	
			ΔV <sub>I</sub> = 3 V to 14 V	3 5 7	
			ΔV <sub>I</sub> = 14 V to 25 V	3 5 7	
V <sub>I(open)</sub>	Open-circuit input voltage	3	I <sub>I</sub> = 0	0 0.2 2	V
I <sub>OS</sub>	Short-circuit output current <sup>†</sup>	4	V <sub>CC1</sub> = 5.5 V, V <sub>I</sub> = -5 V	-10 -20 -40	mA
I <sub>CC1</sub>	Supply current from V <sub>CC1</sub>	5	V <sub>CC1</sub> = 5.5 V, T <sub>A</sub> = 25°C	20 35	mA
I <sub>CC2</sub>	Supply current from V <sub>CC2</sub>		V <sub>CC2</sub> = 13.2 V, T <sub>A</sub> = 25°C	23 40	

<sup>†</sup>Not more than one output should be shorted at a time.

<sup>‡</sup>All typical values are at V<sub>CC1</sub> = 5 V, T<sub>A</sub> = 25°C.

NOTE 3: The algebraic convention, where the less-positive (more-negative) limit is designated as minimum, is used in this data sheet for logic and threshold levels only, e.g., when 0 V is the maximum, the minimum limit is a more negative voltage.

switching characteristics, V<sub>CC1</sub> = 5 V, T<sub>A</sub> = 25°C, N = 10

PARAMETER		TEST FIGURE	TEST CONDITIONS	MIN TYP MAX	UNIT
t <sub>PLH</sub>	Propagation delay time, low-to-high-level output	6	C <sub>L</sub> = 50 pF, R <sub>L</sub> = 390 Ω	22	ns
t <sub>PHL</sub>	Propagation delay time, high-to-low-level output			20	ns
t <sub>TLH</sub>	Transition time, low-to-high-level output			9	ns
t <sub>THL</sub>	Transition time, high-to-low-level output			6	ns

## TYPICAL CHARACTERISTICS

OUTPUT VOLTAGE vs INPUT VOLTAGE

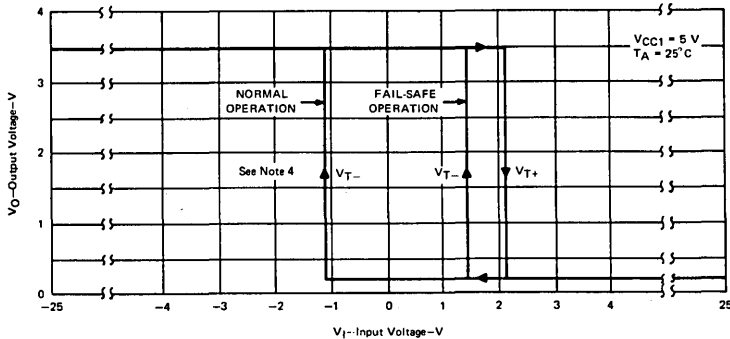

NOTE 4: For normal operation, the threshold controls are connected to V<sub>CC1</sub>, pin 15. For fail-safe operation, the threshold controls are open.

# TYPE SN75154 QUADRUPLE LINE RECEIVER

schematic

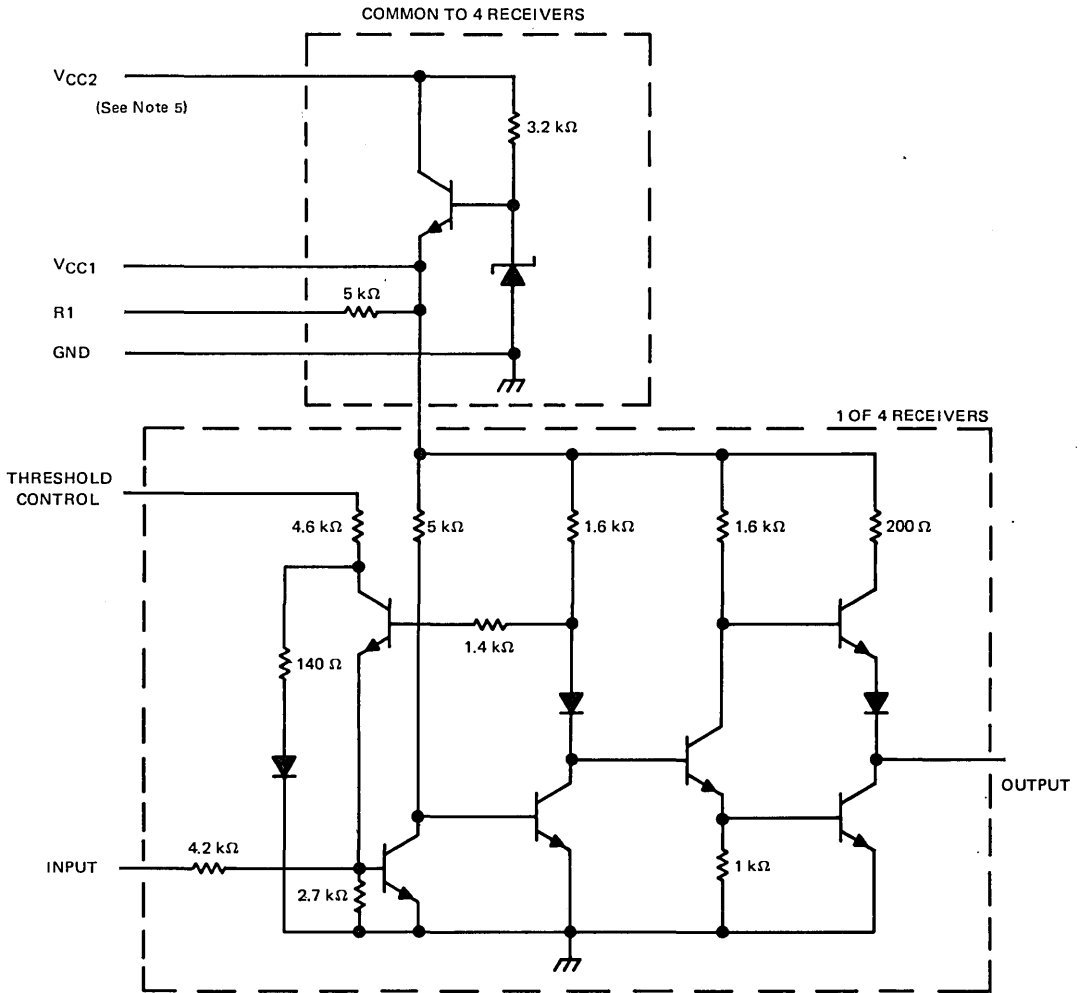

Component values shown are nominal

... Substrate

NOTE 5: When using VCC1 (pin 15), VCC2 (pin 16) may be left open or shorted to VCC1. When using VCC2, VCC1 must be left open or connected to the threshold control pins.

**TEXAS INSTRUMENTS**  
INCORPORATED

POST OFFICE BOX 225012 • DALLAS, TEXAS 75265

5-155

5

# TYPE SN75154 QUADRUPLE LINE RECEIVER

## PARAMETER MEASUREMENT INFORMATION

d-c test circuits<sup>†</sup>

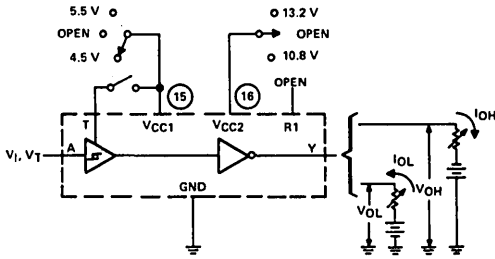

NOTES: A. Momentarily apply  $-5\text{ V}$ , then  $0.8\text{ V}$ .  
B. Momentarily apply  $5\text{ V}$ , then ground.

TEST TABLE

TEST	MEASURE	A	T	Y	VCC1 (PIN 15)	VCC2 (PIN 16)
Open-circuit input (fail safe)	V <sub>OH</sub>	Open	Open	I <sub>OH</sub>	4.5 V	Open
	V <sub>OH</sub>	Open	Open	I <sub>OH</sub>	Open	10.8 V
V <sub>T+</sub> min,	V <sub>OH</sub>	0.8 V	Open	I <sub>OH</sub>	5.5 V	Open
V <sub>T-</sub> min (fail safe)	V <sub>OH</sub>	0.8 V	Open	I <sub>OH</sub>	Open	13.2 V
V <sub>T+</sub> min (normal)	V <sub>OH</sub>	Note A	Pin 15	I <sub>OH</sub>	5.5 V and T	Open
	V <sub>OH</sub>	Note A	Pin 15	I <sub>OH</sub>	T	13.2 V
V <sub>IL</sub> max,	V <sub>OH</sub>	$-3\text{ V}$	Pin 15	I <sub>OH</sub>	5.5 V and T	Open
V <sub>T-</sub> min (normal)	V <sub>OH</sub>	$-3\text{ V}$	Pin 15	I <sub>OH</sub>	T	13.2 V
V <sub>IH</sub> min, V <sub>T+</sub> max,	V <sub>OL</sub>	3 V	Open	I <sub>OL</sub>	4.5 V	Open
V <sub>T-</sub> max (fail safe)	V <sub>OL</sub>	3 V	Open	I <sub>OL</sub>	Open	10.8 V
V <sub>IH</sub> min, V <sub>T+</sub> max (normal)	V <sub>OL</sub>	3 V	Pin 15	I <sub>OL</sub>	4.5 V and T	Open
V <sub>T-</sub> max (normal)	V <sub>OL</sub>	3 V	Pin 15	I <sub>OL</sub>	T	10.8 V
	V <sub>OL</sub>	Note B	Pin 15	I <sub>OL</sub>	5.5 V and T	Open
	V <sub>OL</sub>	Note B	Pin 15	I <sub>OL</sub>	T	13.2 V

FIGURE 1 - V<sub>IH</sub>, V<sub>IL</sub>, V<sub>T+</sub>, V<sub>T-</sub>, V<sub>OH</sub>, V<sub>OL</sub>.

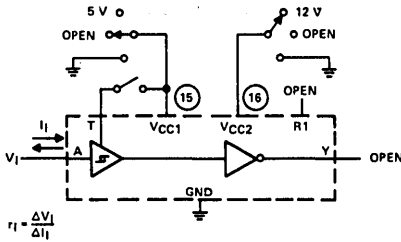

$$r_I = \frac{\Delta V_I}{\Delta I_I}$$

TEST TABLE

T	VCC1 (PIN 15)	VCC2 (PIN 16)
Open	5 V	Open
Open	GND	Open
Open	Open	Open
Pin 15	T and 5 V	Open
GND	GND	Open
Open	Open	12 V
Open	Open	GND
Pin 15	T	12 V
Pin 15	T	GND
Pin 15	T	Open

FIGURE 2 -  $r_I$

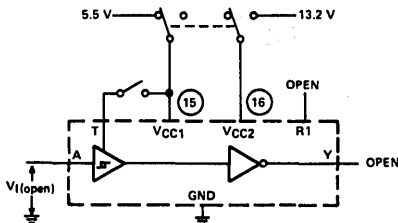

TEST TABLE

T	VCC1 (PIN 15)	VCC2 (PIN 16)
Open	5.5 V	Open
Pin 15	5.5 V	Open
Open	Open	13.2 V
Pin 15	T	13.2 V

FIGURE 3 - V<sub>I(open)</sub>

<sup>†</sup>Arrows indicate actual direction of current flow. Current into a terminal is a positive value.

# TYPE SN75154 QUADRUPLE LINE RECEIVER

## PARAMETER MEASUREMENT INFORMATION

d-c test circuits† (continued)

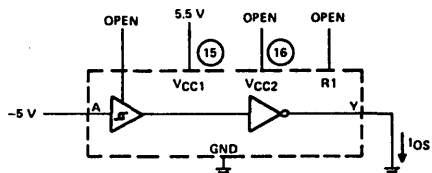

Each output is tested separately.

FIGURE 4—IOS

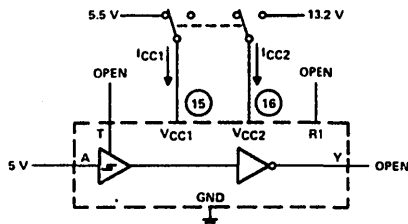

All four line receivers are tested simultaneously.

FIGURE 5—ICC

† Arrows indicate actual direction of current flow. Current into a terminal is a positive value.

switching characteristics

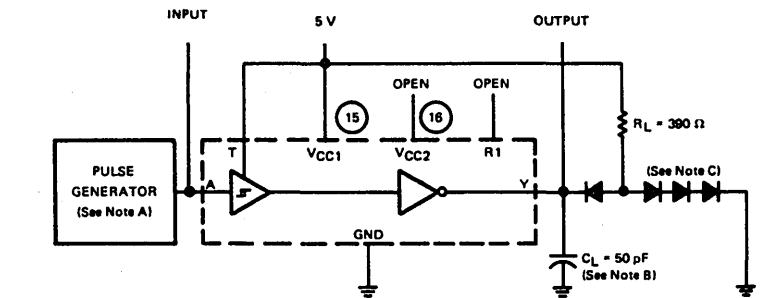

TEST CIRCUIT

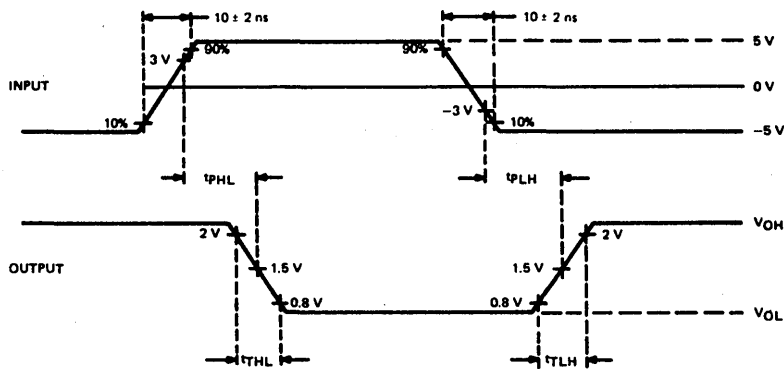

VOLTAGE WAVEFORMS

- NOTES: A. The pulse generator has the following characteristics:  $Z_{out} = 50 \Omega$ ,  $t_w = 200 \text{ ns}$ , duty cycle  $< 20\%$ .  
 B.  $C_L$  includes probe and jig capacitance.  
 C. All diodes are 1N3064.

FIGURE 6—SWITCHING TIMES

## FUTURE PRODUCTS TO BE ANNOUNCED

## TYPE SN75156 DUAL LINE DRIVER

OCTOBER 1980

- Meets EIA Standards RS-232C and RS-423A
- Wide Supply Voltage Range . . .  $\pm 7.5$  V  
To  $\pm 15$  V
- Low Supply Current . . . 4.5 mA Max per Channel
- Wave Shaping with External Resistor
- Inputs Compatible with TTL and CMOS
- Outputs at High Impedance when Power Is Off
- Positive- and Negative-Current Limiting
- Designed for Interchangeability with uA9636A
- Quad Version is SN75186

### description

The SN75156 is a single-ended line driver designed to meet the requirements of EIA Standards RS-232C and RS-423A, CCITT Recommendations V.10, V.28, and X.26, and Federal Standard FIPS 1030. This device maintains regulated high and low output levels of 5.5 volts and  $-5.5$  volts, respectively, over a wide range of power supply voltages. The output transition time for both drivers can be adjusted from 1 microsecond to 100 microseconds by means of an external resistor at the wave shaping (WS) pin. A high output impedance is maintained without the use of an external blocking diode.

JG OR P PACKAGE  
(TOP VIEW)

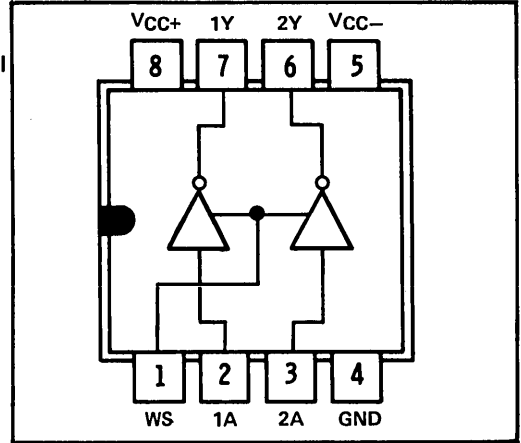

### PRODUCT PREVIEW

This document contains information on a product under development. Texas Instruments reserves the right to change or discontinue this product without notice.

**TEXAS INSTRUMENTS**  
INCORPORATED

POST OFFICE BOX 225012 • DALLAS, TEXAS 75265

- Meets EIA Standards RS-422A and RS-423A
- Meets Federal Standards 1020 and 1030
- Operates from Single 5-V Power Supply
- Wide Common-Mode Voltage Range
- High Input Impedance
- TTL-Compatible Outputs
- High-Speed Schottky Circuitry
- 8-Pin Dual-In-Line Package
- Similar to  $\mu$ A9637AC But With Standard  $V_{CC}$  and Ground Pin Position

JG OR P DUAL-IN-LINE PACKAGE  
(TOP VIEW)

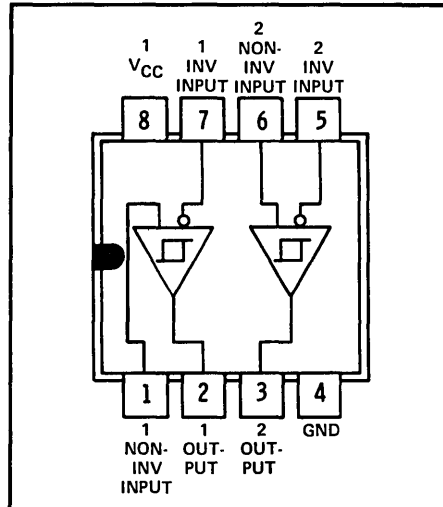

**description**

The SN75157 is a dual differential line receiver designed to meet EIA standards RS-422A and RS-423A. It utilizes Schottky† circuitry and has TTL-compatible outputs. The inputs are compatible with either a single-ended or a differential-line system. This device operates from a single 5-volt power supply and is supplied in an 8-pin dual-in-line package.

The SN75157 is characterized for operation from 0°C to 70°C.

**schematics of inputs and outputs**

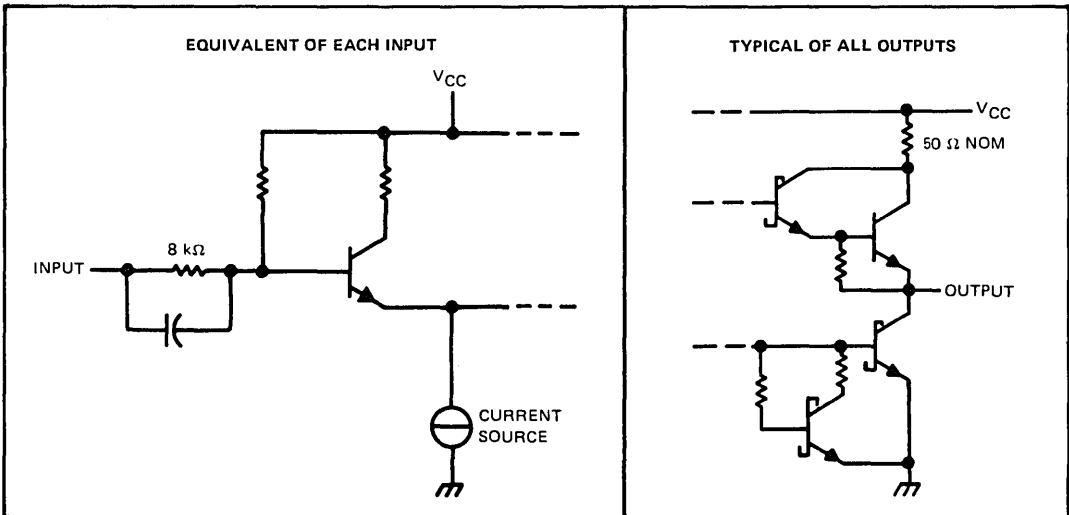

Copyright © 1980 by Texas Instruments Incorporated

# TYPE SN75157 DUAL DIFFERENTIAL LINE RECEIVER

absolute maximum ratings over operating free-air temperature range (unless otherwise noted)

Supply voltage range, $V_{CC}$ (see Note 1)	.....	-0.5 V to 7 V
Input voltage	.....	$\pm 15$ V
Differential input voltage (see Note 2)	.....	$\pm 15$ V
Output voltage (see Note 1)	.....	-0.5 V to 5.5 V
Low-level output current	.....	50 mA
Continuous total dissipation at (or below) 25°C free-air temperature (see Note 3):		
	JG package	825 mA
	P package	1000 mA
Operating free-air temperature range	.....	0°C to 70°C
Storage temperature range	.....	-65°C to 150°C
Lead temperature 1/16 inch (1,6 mm) from case for 60 seconds:	JG package	300°C
Lead temperature 1/16 inch (1,6 mm) from case for 10 seconds:	P package	260°C

- NOTES: 1. All voltage values, except differential-input voltage, are with respect to the network ground terminal.  
 2. Differential-input voltage is measured at the noninverting input with respect to the corresponding inverting input.  
 3. For operation above 25°C free-air temperature, derate the JG package to 528 mW at 70°C at the rate of 6.6 mW/°C and the P package to 640 mW at 70°C at the rate of 8.0 mW. In the JG package, SN75157 chips are glass-mounted.

5

## recommended operating conditions

	MIN	NOM	MAX	UNIT
Supply voltage, $V_{CC}$	4.75	5	5.25	V
Common-mode input voltage, $V_{IC}$			$\pm 7$	V
Operating free-air temperature, $T_A$	0	25	70	°C

electrical characteristics over recommended ranges of supply voltage, common-mode input voltage, and operating free-air temperature (unless otherwise noted)

PARAMETER	TEST CONDITIONS	MIN	TYP <sup>†</sup>	MAX	UNIT
$V_T$ Threshold voltage ( $V_{T+}$ and $V_{T-}$ )	See Note 5	-0.2		0.2	V
$V_{T+} - V_{T-}$ Hysteresis		-0.4		0.4	mV
$V_{OH}$ High-level output voltage	$V_{ID} = 0.2$ V, $I_O = -1$ mA	2.5	3.5		V
$V_{OL}$ Low-level output voltage	$V_{ID} = -0.2$ V, $I_O = 20$ mA	0.35	0.5		V
$I_I$ Input current	$V_{CC} = 0$ to 5.5 V, See Note 6	$V_I = 10$ V	1.1	3.25	mA
		$V_I = -10$ V	-1.6	-3.25	
$I_{OS}$ Short-circuit input current <sup>‡</sup>	$V_O = 0$ , $V_{ID} = 0.2$ V	-40	-75	-100	mA
$I_{CC}$ Supply current	$V_{ID} = -0.5$ V, No load		35	50	mA

<sup>†</sup>All typical values are at  $V_{CC} = 5$  V,  $T_A = 25^\circ$  C.

<sup>‡</sup>Only one output should be shorted at a time, and duration of the short-circuit should not exceed one second.

- NOTES: 4. The algebraic convention, where the less-positive (more-negative) limit is designated as minimum, is used in this data sheet for threshold levels only.  
 5. The expanded threshold parameter is tested with a 500- $\Omega$  resistor in series with each input.  
 6. The input not under test is grounded.

## switching characteristics, $V_{CC} = 5$ V, $T_A = 25^\circ$ C

PARAMETER	TEST CONDITION	MIN	TYP	MAX	UNIT
<sup>t</sup> PLH Propagation delay time, low-to-high-level output	$C_L = 30$ pF, See Figure 1		15	25	ns
<sup>t</sup> PHL Propagation delay time, high-to-low-level output			13	25	ns



# TYPE SN75157 DUAL DIFFERENTIAL LINE RECEIVER

## PARAMETER MEASUREMENT INFORMATION

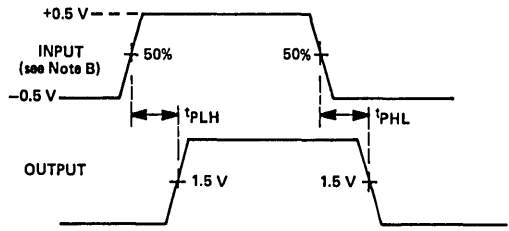
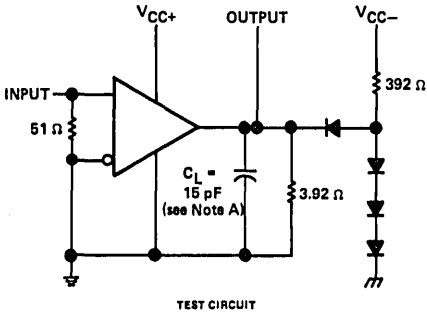

NOTES: A.  $C_L$  includes probe and jig capacitance.

B. The input pulse is supplied by a generator having the following characteristics:  $t_r \leq 5$  ns,  $t_f = 5$  ns, PRR = 5 MHz, duty cycle = 10%.

FIGURE 1—TRANSITION TIMES

## TYPICAL CHARACTERISTICS

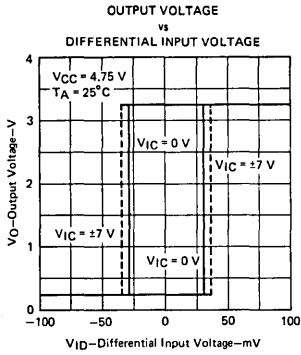

FIGURE 2

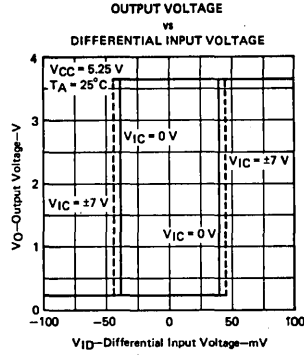

FIGURE 3

## TYPICAL APPLICATION DATA

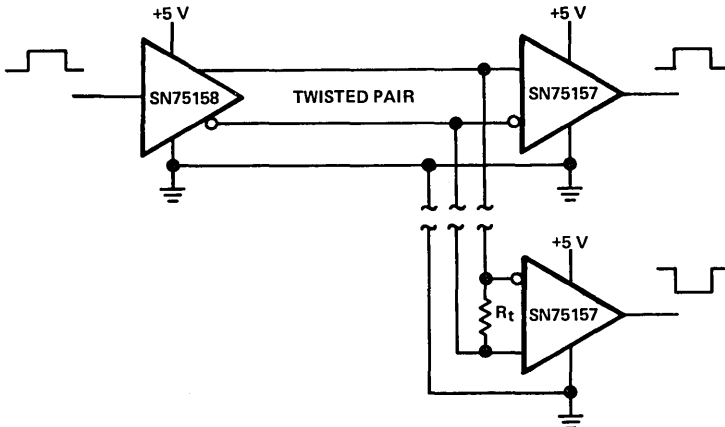

FIGURE 4—RS-422A SYSTEM APPLICATIONS

TEXAS INSTRUMENTS  
INCORPORATED

POST OFFICE BOX 225012 • DALLAS, TEXAS 75265

# INTERFACE CIRCUITS

# TYPES SN55158, SN75158 DUAL DIFFERENTIAL LINE DRIVERS

BULLETIN NO. DL-S 12497, JANUARY 1977

- Meets EIA Standard RS-422
- Single 5-V Supply
- Balanced-Line Operation
- TTL-, DTL-Compatible
- High Output Impedance in Power-Off Condition
- High-Current Active-Pull-Up Outputs
- Short-Circuit Protection
- Dual Channels
- Input Clamp Diodes

SN55158 ... JG DUAL-IN-LINE PACKAGE  
SN75158 ... JG OR P DUAL-IN-LINE PACKAGE  
(TOP VIEW)

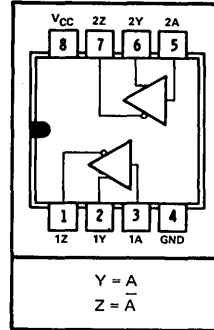

## description

The SN55158 and SN75158 are dual complementary-output line drivers designed to satisfy the requirements set by the EIA RS-422 standard interface specifications. The inputs are standard TTL. The outputs provide complementary signals with high-current capability for driving balanced lines, such as twisted-pair, at normal line impedance without high power dissipation. The output stages are TTL totem-pole outputs providing a high-impedance state in the power-off condition.

## schematic (each driver)

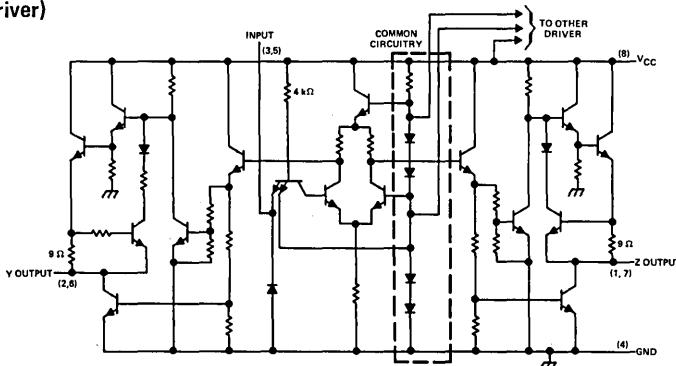

Components within the dashed box are common to both drivers. Resistor values shown are nominal.

## absolute maximum ratings over operating free-air temperature range (unless otherwise noted)

Supply voltage, $V_{CC}$ (see Note 1)	7 V
Input voltage	5.5 V
Continuous total dissipation at (or below) 25°C free-air temperature (see Note 2)	1 W
Operating free-air temperature range: SN55158	-55°C to 125°C
SN75158	0°C to 70°C
Storage temperature range	-65°C to 150°C
Lead temperature 1/16 inch from case for 60 seconds: JG package	300°C
Lead temperature 1/16 inch from case for 10 seconds: P package	260°C

NOTES: 1. All voltage values except, differential output voltage  $V_{OD}$ , are with respect to network ground terminal.  $V_{OD}$  is at the Y output with respect to the Z output.

2. For operation above 25°C free-air temperature, refer to Dissipation Derating Curves in the Thermal Information section, which starts on page 2-1. In the JG package, SN55158 chips are alloy-mounted; SN75158 chips are glass-mounted.

# TYPES SN55158, SN75158 DUAL DIFFERENTIAL LINE DRIVERS

## recommended operating conditions

	SN55158			SN75158			UNIT
	MIN	NOM	MAX	MIN	NOM	MAX	
Supply voltage, $V_{CC}$	4.5	5	5.5	4.75	5	5.25	V
High-level output current, $I_{OH}$			-40			-40	mA
Low-level output current, $I_{OL}$			40			40	mA
Operating free-air temperature, $T_A$	-55		125	0		70	°C

## electrical characteristics over operating free-air temperature range (unless otherwise noted)

PARAMETER	TEST CONDITIONS†	SN55158		SN75158		UNIT			
		MIN	TYP‡	MAX	MIN		TYP‡	MAX	
$V_{IH}$ High-level input voltage		2			2	V			
$V_{IL}$ Low-level input voltage				0.8		0.8	V		
$V_{IK}$ Input clamp voltage	$V_{CC} = \text{MIN}, I_I = -12 \text{ mA}$	-0.9		-1.5	-0.9	-1.5	V		
$V_{OH}$ High-level output voltage	$V_{CC} = \text{MIN}, V_{IH} = 2 \text{ V}, I_{OH} = -40 \text{ mA}$	2	3.0		2.4	3.0	V		
$V_{OL}$ Low-level output voltage	$V_{CC} = \text{MIN}, V_{IH} = 2 \text{ V}, I_{OL} = 40 \text{ mA}$		0.2	0.4		0.2	0.4	V	
$V_{OD1}$ Differential output voltage	$V_{CC} = \text{MAX}, I_O = 0$		3.5	$2V_{OD2}$		3.5	$2V_{OD2}$	V	
$V_{OD2}$ Differential output voltage	$V_{CC} = \text{MIN}$	2	3.0		2	3.0		V	
$\Delta V_{OD}$ Change in magnitude of differential output voltage §	$V_{CC} = \text{MIN}$		±0.02	±0.4		±0.02	±0.4	V	
$V_{OC}$ Common-mode output voltage ¶	$V_{CC} = \text{MAX}$		1.9	3		1.8	3	V	
	$V_{CC} = \text{MIN}$		1.4	3		1.5	3	V	
$\Delta V_{OC}$ Change in magnitude of common-mode output voltage §	$V_{CC} = \text{MIN or MAX}$		±0.01	±0.4		±0.01	±0.4	V	
$I_O$ Output current with power off	$V_{CC} = 0$	$V_O = 6 \text{ V}$		0.1	100		0.1	100	µA
		$V_O = -0.25 \text{ V}$		-0.1	-100		-0.1	-100	
		$V_O = -0.25 \text{ V to } 6 \text{ V}$			±100			±100	
$I_I$ Input current at maximum input voltage	$V_{CC} = \text{MAX}, V_I = 5.5 \text{ V}$			1			1	mA	
$I_{IH}$ High-level input current	$V_{CC} = \text{MAX}, V_I = 2.4 \text{ V}$			40			40	µA	
$I_{IL}$ Low-level input current	$V_{CC} = \text{MAX}, V_I = 0.4 \text{ V}$			-1	-1.6		-1	-1.6	mA
$I_{OS}$ Short-circuit output current #	$V_{CC} = \text{MAX}$	-40	-90	-150	-40	-90	-150	mA	
$I_{CC}$ Supply current (both drivers)	$V_{CC} = \text{MAX},$ No load, $T_A = 25^\circ\text{C}$		37	50		37	50	mA	

† For conditions shown as MIN or MAX, use the appropriate value specified under recommended operating conditions.

‡ All typical values are at  $V_{CC} = 5 \text{ V}$  and  $T_A = 25^\circ\text{C}$  except for  $V_{OC}$ , for which  $V_{CC}$  is as stated under test conditions.

§  $\Delta V_{OD}$  and  $\Delta V_{OC}$  are the changes in magnitudes of  $V_{OD}$  and  $V_{OC}$ , respectively, that occur when the input is changed from a high level to a low level.

¶ In EIA Standard RS-422,  $V_{OC}$ , which is the average of the two output voltages with respect to ground, is called output offset voltage,  $V_{OS}$ .

# Only one output should be shorted at a time, and duration of the short-circuit should not exceed one second.

# TYPES SN55158, SN75158 DUAL DIFFERENTIAL LINE DRIVERS

switching characteristics,  $V_{CC} = 5\text{ V}$ ,  $T_A = 25^\circ\text{C}$

PARAMETER	TEST CONDITIONS	SN55158			SN75158			UNIT
		MIN	TYP	MAX	MIN	TYP	MAX	
$t_{PLH}$ Propagation delay time, low-to-high-level output	See Figure 2,		16	25		16	25	ns
$t_{PHL}$ Propagation delay time, high-to-low-level output	Termination A		10	20		10	20	ns
$t_{PLH}$ Propagation delay time, low-to-high-level output	See Figure 2,		13	20		13	20	ns
$t_{PHL}$ Propagation delay time, high-to-low-level output	Termination B		9	15		9	15	ns
$t_{TLH}$ Transition time, low-to-high-level output	See Figure 2,		4	20		4	20	ns
$t_{THL}$ Transition time, high-to-low-level output	Termination A		4	20		4	20	ns
Overshoot factor	See Figure 2, Termination C			10			10	%

## PARAMETER MEASUREMENT INFORMATION

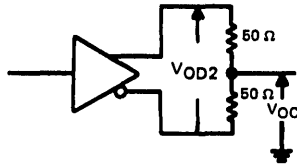
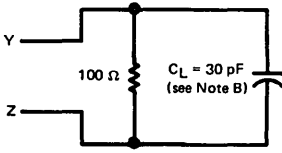
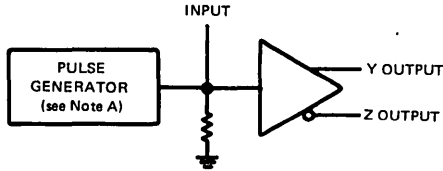
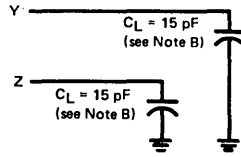

FIGURE 1—DIFFERENTIAL AND COMMON-MODE OUTPUT VOLTAGES



TERMINATION A



TERMINATION B

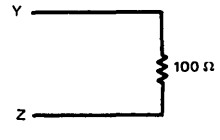

TERMINATION C

## TEST CIRCUIT

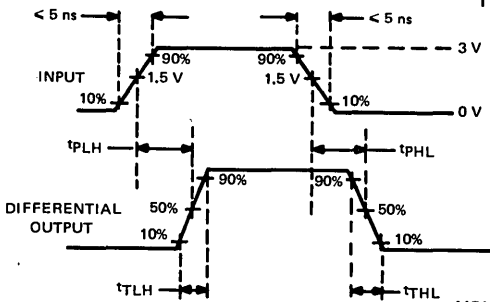

VOLTAGE WAVEFORMS

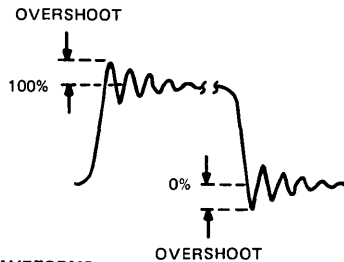

NOTES: A. The pulse generator has the following characteristics:  $Z_{out} = 50\ \Omega$ ,  $t_w = 25\text{ ns}$ ,  $PRR = 10\text{ MHz}$ .  
B.  $C_L$  includes probe and jig capacitance.

FIGURE 2—SWITCHING TIMES

# TYPES SN55158, SN75158 DUAL DIFFERENTIAL LINE DRIVERS

## TYPICAL CHARACTERISTICS†

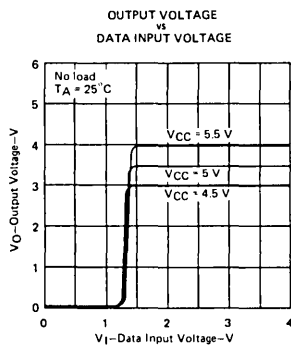

FIGURE 3

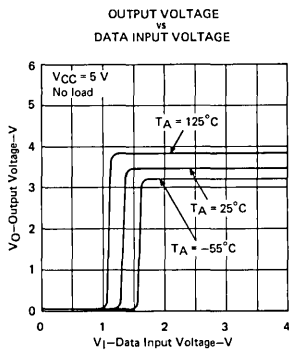

FIGURE 4

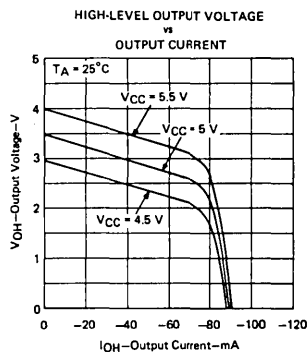

FIGURE 5

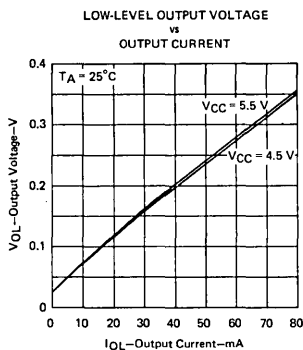

FIGURE 6

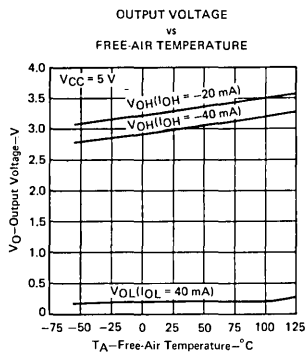

FIGURE 7

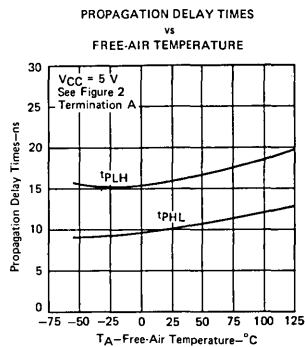

FIGURE 8

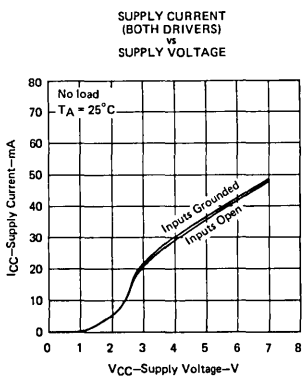

FIGURE 9

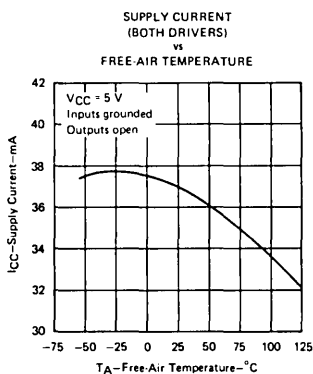

FIGURE 10

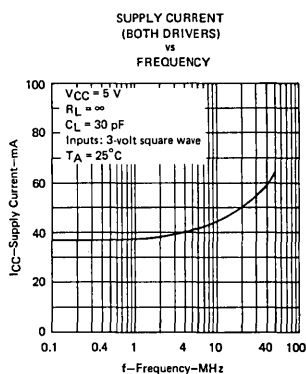

FIGURE 11

† Data for temperatures below 0°C and above 70°C are applicable to SN55158 circuits only.

# INTERFACE CIRCUITS

# TYPE SN75159 DUAL DIFFERENTIAL LINE DRIVER WITH 3-STATE OUTPUTS

BULLETIN NO. DL-S 12501, JANUARY 1977

- Meets EIA Standard RS-422
- Single 5-V Supply
- Balanced Line Operation
- TTL and DTL Compatible
- High-Impedance Output State for Party-Line Applications
- High-Current Active-Pull-Up Outputs
- Short-Circuit Protection
- Dual Channels
- Clamp Diodes at Inputs

### description

The SN75159 dual differential line driver with three-state outputs is designed to provide all the features of the SN75158 line driver with the added feature of driver output controls. There is an individual control for each driver. When the output control is low, the associated outputs are in a high-impedance state and the outputs can neither drive nor load the bus. This permits many devices to be connected together on the same transmission line for party-line applications.

### schematic (each driver)

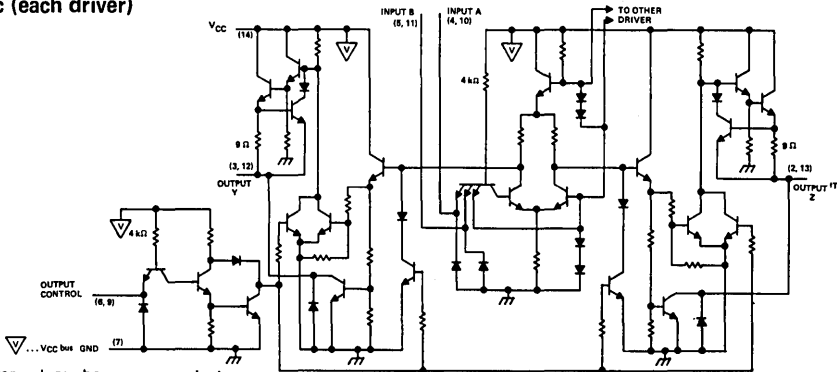

### absolute maximum ratings over operating free-air temperature range (unless otherwise noted)

Supply voltage, $V_{CC}$ (see Note 1)	7 V
Input voltage	5.5 V
Off-state voltage applied to open-collector outputs	12 V
Continuous total dissipation at (or below) 25°C free-air temperature (see Note 2): J package	1025 mW
N package	1150 mW
Operating free-air temperature range	0°C to 70°C
Storage temperature range	-65°C to 150°C
Lead temperature 1/16 inch from case for 60 seconds: J package	300°C
Lead temperature 1/16 inch from case for 10 seconds: N package	260°C

NOTES: 1. All voltage values, except differential output voltage  $V_{OD}$ , are with respect to network ground terminal.  $V_{OD}$  is at the Y output with respect to the Z output.

2. For operation above 25°C free-air temperature, refer to Dissipation Derating Curves in the Thermal Information section, which starts on page 2-1. In the J package, SN75159 chips are glass-mounted.

J OR N DUAL-IN-LINE PACKAGE  
(TOP VIEW)

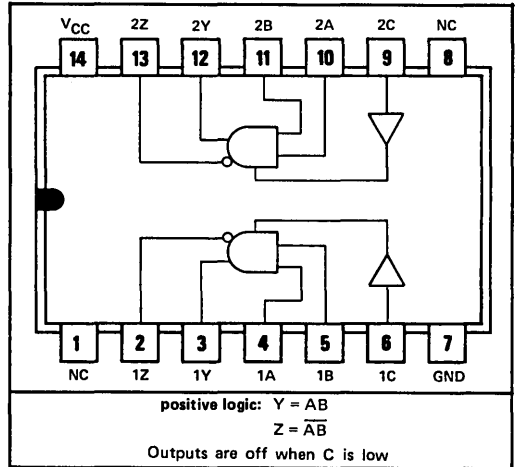

NC—No internal connection

# TYPE SN75159

## DUAL DIFFERENTIAL LINE DRIVER WITH 3-STATE OUTPUTS

### recommended operating conditions

	MIN	NOM	MAX	UNIT
Supply voltage, $V_{CC}$	4.75	5	5.25	V
High-level output current, $I_{OH}$			-40	mA
Low-level output current, $I_{OL}$			40	mA
Operating free-air temperature, $T_A$	0		70	°C

### electrical characteristics over operating free-air temperature range (unless otherwise noted)

PARAMETER	TEST CONDITIONS†		MIN	TYP‡	MAX	UNIT
$V_{IH}$	High-level input voltage		2			V
$V_{IL}$	Low-level input voltage				0.8	V
$V_{IK}$	Input clamp voltage		$V_{CC} = \text{MIN}, I_I = -12 \text{ mA}$		-0.9 -1.5	V
$V_{OH}$	High-level output voltage		$V_{CC} = \text{MIN}, V_{IH} = 2 \text{ V}, I_{OH} = -40 \text{ mA}$		2.4 3.0	V
$V_{OL}$	Low-level output voltage		$V_{CC} = \text{MIN}, V_{IH} = 2 \text{ V}, I_{OL} = 40 \text{ mA}$		0.25 0.4	V
$V_{OK}$	Output clamp voltage		$V_{CC} = \text{MAX}, I_O = -40 \text{ mA}$		-1.1 -1.5	V
$ V_{OD1} $	Differential output voltage		$V_{CC} = \text{MAX}, I_O = 0$		3.5 $2V_{OD2}$	V
$ V_{OD2} $	Differential output voltage		$V_{CC} = \text{MIN}$		2 3.0	V
$\Delta  V_{OD} $	Change in magnitude of differential output voltage §		$V_{CC} = \text{MIN}$		$\pm 0.02$ $\pm 0.4$	V
$V_{OC}$	Common-mode output voltage ¶		$V_{CC} = \text{MAX}$ $V_{CC} = \text{MIN}$		1.8 3 1.5 3	V
$\Delta  V_{OC} $	Change in magnitude of common-mode output voltage §		$V_{CC} = \text{MIN or MAX}$		$\pm 0.01$ $\pm 0.4$	V
$I_O$	Output current with power off		$V_{CC} = 0$		$V_O = 6 \text{ V}$ 0.1 100 $V_O = -0.25 \text{ V}$ -0.1 -100 $V_O = -0.25 \text{ V to } 6 \text{ V}$ $\pm 100$	$\mu\text{A}$
$I_{OZ}$	Off-state (high-impedance-state) output current		$V_{CC} = \text{MAX},$ Output controls at 0.8 V		$T_A = 25^\circ\text{C}, V_O = 0 \text{ to } V_{CC}$ $\pm 10$ $V_O = 0$ -20 $V_O = 0.4 \text{ V}$ $\pm 20$ $V_O = 2.4 \text{ V}$ $\pm 20$ $V_O = V_{CC}$ 20	$\mu\text{A}$
$I_I$	Input current at maximum input voltage		$V_{CC} = \text{MAX}, V_I = 5.5 \text{ V}$		1	mA
$I_{IH}$	High-level input current		$V_{CC} = \text{MAX}, V_I = 2.4 \text{ V}$		40	$\mu\text{A}$
$I_{IL}$	Low-level input current		$V_{CC} = \text{MAX}, V_I = 0.4 \text{ V}$		-1 -1.6	mA
$I_{OS}$	Short-circuit output current #		$V_{CC} = \text{MAX}$		-40 -90 -150	mA
$I_{CC}$	Supply current (both drivers)		$V_{CC} = \text{MAX}, T_A = 25^\circ\text{C}$ Inputs grounded, No load,		47 65	mA

† For conditions shown as MIN or MAX, use the appropriate value specified under recommended operating conditions.

‡ All typical values are at  $V_{CC} = 5 \text{ V}$  and  $T_A = 25^\circ\text{C}$  except for  $V_{OC}$ , for which  $V_{CC}$  is as stated under test conditions.

§  $\Delta |V_{OD}|$  and  $\Delta |V_{OC}|$  are the changes in magnitudes of  $V_{OD}$  and  $V_{OC}$ , respectively, that occur when the input is changed from a high level to a low level.

¶ In EIA Standard RS-422,  $V_{OC}$ , which is the average of the two output voltages with respect to ground, is called output offset voltage,  $V_{OS}$ .

# Only one output should be shorted at a time, and duration of the short-circuit should not exceed one second.

5

# TYPE SN75159

## DUAL DIFFERENTIAL LINE DRIVER WITH 3-STATE OUTPUTS

switching characteristics,  $V_{CC} = 5\text{ V}$ ,  $T_A = 25^\circ\text{C}$

PARAMETER	TEST CONDITIONS	MIN	TYP	MAX	UNIT
$t_{PLH}$ Propagation delay time, low-to-high-level output	$C_L = 30\text{ pF}$ , $R_L = 100\ \Omega$ , See Figure 2, Termination A		16	25	ns
$t_{PHL}$ Propagation delay time, high-to-low-level output			11	20	ns
$t_{PLH}$ Propagation delay time, low-to-high-level output	$C_L = 15\text{ pF}$ , See Figure 2, Termination B		13	20	ns
$t_{PHL}$ Propagation delay time, high-to-low-level output			9	15	ns
$t_{TLH}$ Transition time, low-to-high-level output	$C_L = 30\text{ pF}$ , $R_L = 100\ \Omega$ , See Figure 2, Termination A		4	20	ns
$t_{THL}$ Transition time, high-to-low-level output			4	20	ns
$t_{PZH}$ Output enable time to high level	$C_L = 30\text{ pF}$ , $R_L = 180\ \Omega$ , See Figure 3		7	20	ns
$t_{PZL}$ Output enable time to low level	$C_L = 30\text{ pF}$ , $R_L = 250\ \Omega$ , See Figure 4		14	40	ns
$t_{PHZ}$ Output disable time from high level	$C_L = 30\text{ pF}$ , $R_L = 180\ \Omega$ , See Figure 3		10	30	ns
$t_{PLZ}$ Output disable time from low level	$C_L = 30\text{ pF}$ , $R_L = 250\ \Omega$ , See Figure 4		17	35	ns
Overshoot factor	$R_L = 100\ \Omega$ , See Figure 2, Termination C			10	%

### PARAMETER MEASUREMENT INFORMATION

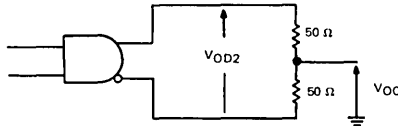
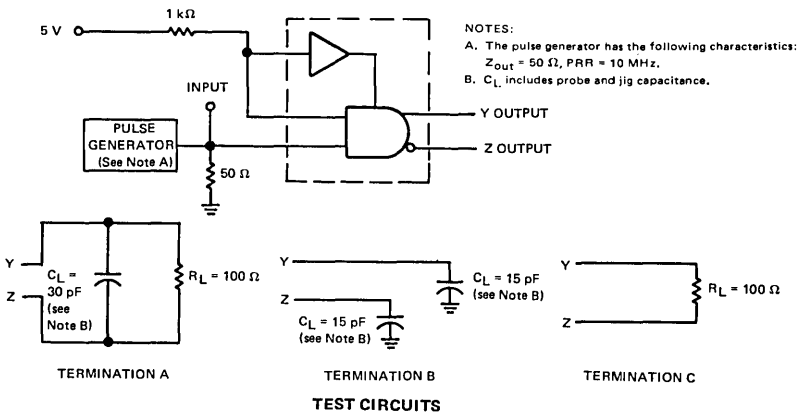
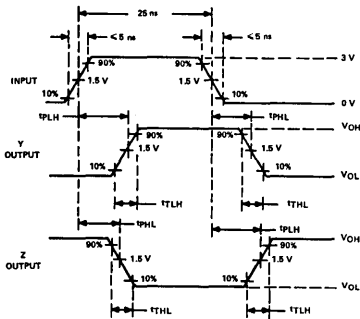

FIGURE 1—DIFFERENTIAL AND COMMON-MODE OUTPUT VOLTAGES



TEST CIRCUITS



VOLTAGE WAVEFORMS

FIGURE 2— $t_{PLH}$ ,  $t_{PHL}$ ,  $t_{TLH}$ ,  $t_{THL}$ , AND OVERSHOOT FACTOR

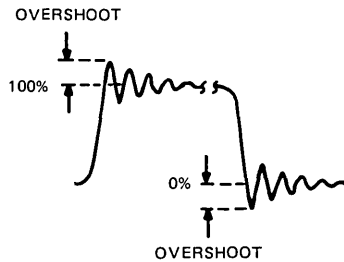



# TYPE SN75159 DUAL DIFFERENTIAL LINE DRIVER WITH 3-STATE OUTPUTS

## PARAMETER MEASUREMENT INFORMATION

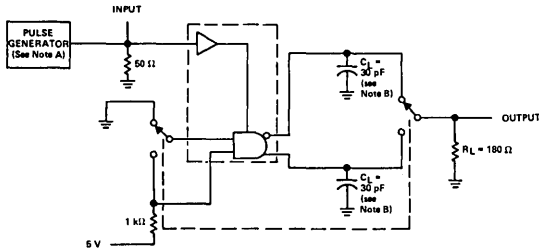

TEST CIRCUIT

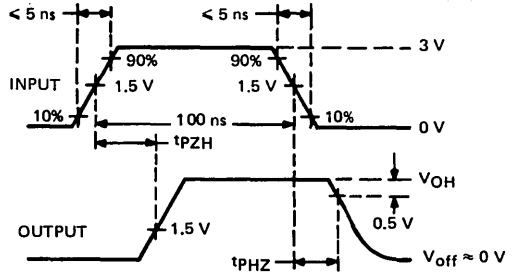

VOLTAGE WAVEFORMS

FIGURE 3— $t_{pZH}$  AND  $t_{pHZ}$

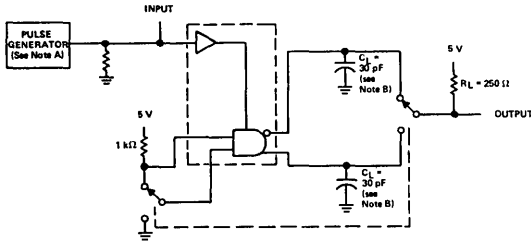

TEST CIRCUIT

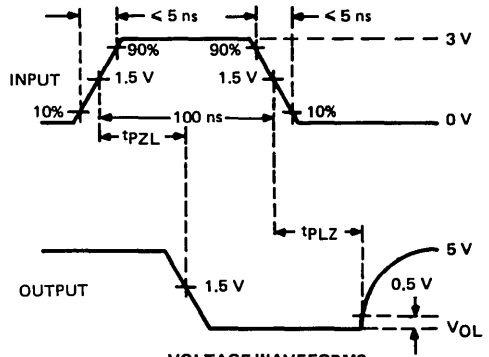

VOLTAGE WAVEFORMS

FIGURE 4— $t_{pZL}$  AND  $t_{pLZ}$

NOTES: A. The pulse generators have the following characteristics:  $Z_{out} = 50\ \Omega$ , PRR = 500 kHz  
B.  $C_L$  Includes probe and jig capacitance.

## TYPICAL CHARACTERISTICS

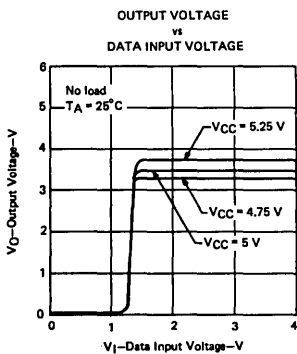

FIGURE 5

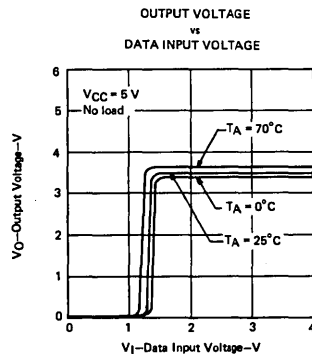

FIGURE 6

**TEXAS INSTRUMENTS  
INCORPORATED**

POST OFFICE BOX 225012 • DALLAS, TEXAS 75265

# TYPE SN75159

## DUAL DIFFERENTIAL LINE DRIVER WITH 3-STATE OUTPUTS

### TYPICAL CHARACTERISTICS

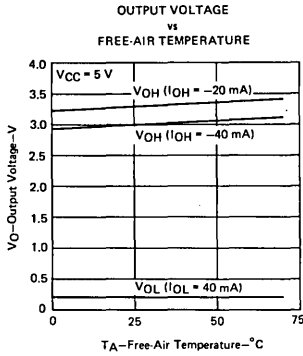

FIGURE 7

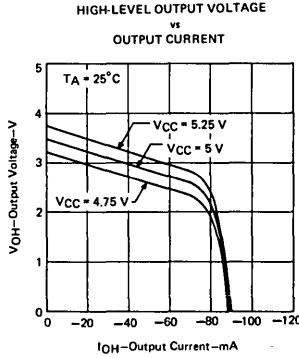

FIGURE 8

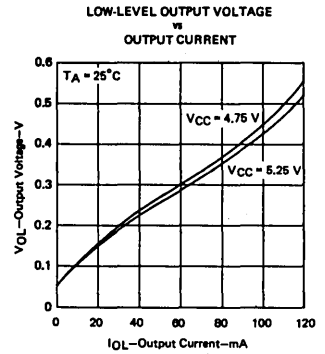

FIGURE 9

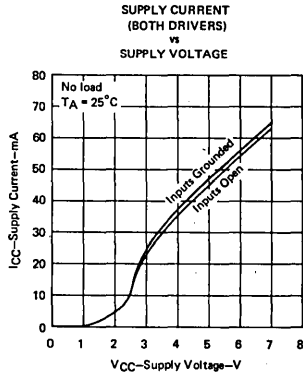

FIGURE 10

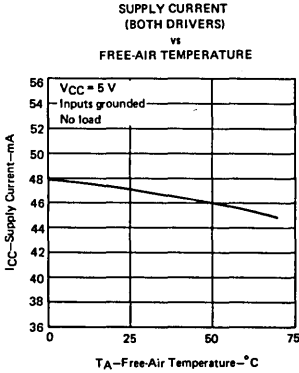

FIGURE 11

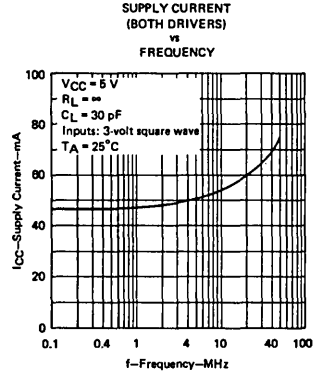

FIGURE 12

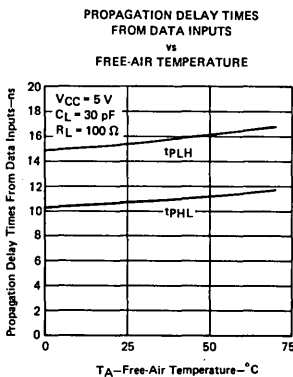

FIGURE 13

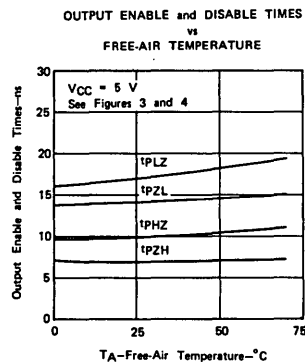

FIGURE 14

# INTERFACE CIRCUITS

# TYPE SN75160A OCTAL GENERAL-PURPOSE INTERFACE BUS TRANSCEIVER

BULLETIN NO. DL-S 12786, OCTOBER 1980

MEETS IEEE STANDARD 488-1978 (GPIB)

- 8-Channel Bidirectional Transceiver
- High-Speed, Low-Power Schottky Circuitry†
- Low Power Dissipation . . . 66 mW Max per Channel
- Fast Propagation Times . . . 22 ns Max
- High-Impedance P-N-P Inputs
- Receiver Hysteresis . . . 650 mV Typ
- Open-Collector Driver Output Option
- No Loading of Bus When Device is Powered Down ( $V_{CC} = 0V$ )

### description.

The SN75160A 8-channel general-purpose interface bus transceiver is a monolithic, high-speed, low-power Schottky device designed for two-way data communications over single-ended transmission lines. It is designed to meet the requirements of IEEE Standard 488-1978. The transceiver features driver outputs that can be operated in either the open-collector or three-state mode. If Talk Enable (TE) is high, these ports have the characteristics of open-collector outputs when Pull-up Enable (PE) is low, and of three-state outputs when PE is high. Taking TE low places these ports in the high-impedance state. The driver outputs are designed to handle loads up to 48 milliamperes of sink current.

An active-turn-off feature has been incorporated into the bus-terminating resistors so that the device exhibits a high-impedance to the bus when  $V_{CC} = 0$  volts. When combined with the SN75161A or SN75162A management bus transceivers, the pair provides the complete 16-wire interface for the IEEE 488 bus.

### logic symbol‡

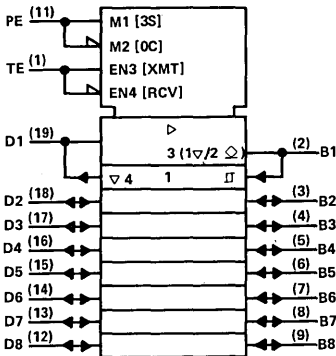

‡ This symbol is in accordance with IEEE Std 91/ANSI Y32.14 and current discussions in IEC and IEEE.

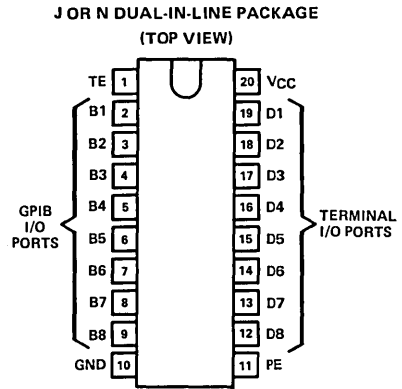

### FUNCTION TABLES

#### DRIVERS

INPUTS			OUTPUT
D	TE	PE	B
H	H	H	H
L	H	X	L
H	X	L	Z*
X	L	X	Z*

#### RECEIVERS

INPUTS			OUTPUTS
B	TE	PE	D
L	L	X	L
H	L	X	H
X	H	X	Z

H = high level, L = low level, X = irrelevant, Z = High-Impedance state.

\* This is the high-impedance state of a normal 3-state output modified by the internal resistors to  $V_{CC}$  and ground.

### functional block diagram (positive logic)

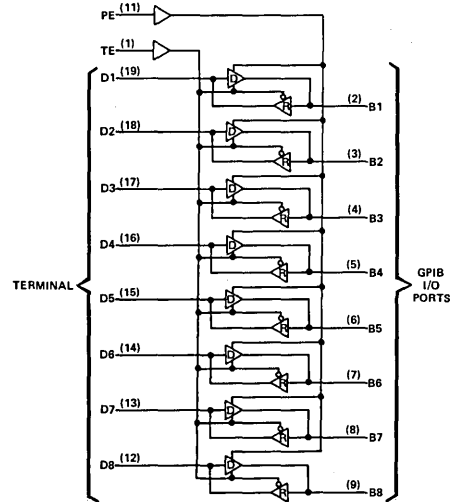

Copyright © 1980 by Texas Instruments Incorporated.

TEXAS INSTRUMENTS  
INCORPORATED

POST OFFICE BOX 225012 • DALLAS, TEXAS 75265

† Integrated Schottky-Barrier diode; clamped transistor is patented by Texas Instruments. U.S. Patent Number 3,463,975. 5-171

# TYPE SN75160A

## OCTAL GENERAL-PURPOSE INTERFACE BUS TRANSCEIVER

schematics of inputs and outputs

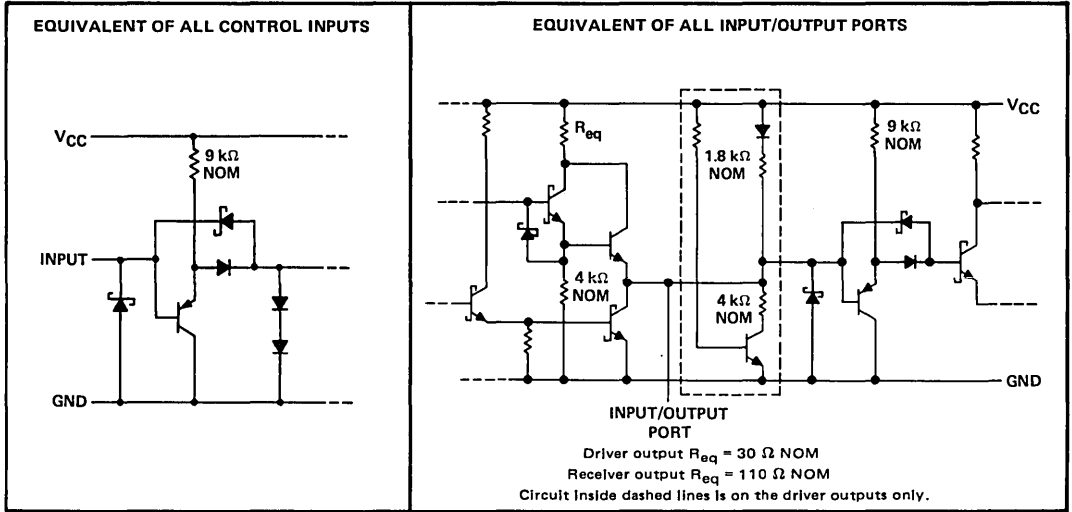

5

absolute maximum ratings over operating free-air temperature range (unless otherwise noted)

Supply voltage, $V_{CC}$ (see Note 1)	7 V
Input voltage	5.5 V
Low-level driver output current	100 mA
Continuous total dissipation at (or below) 25°C free-air temperature (see Note 2): J package	1375 mW
N package	1150 mW
Operating free-air temperature range	0°C to 70°C
Storage temperature range	-65°C to 150°C
Lead temperature 1/16 (1,6 mm) from case for 10 seconds	260°C

NOTES: 1. All voltage values are with respect to network ground terminal.

2. For operation above 25°C free-air temperature, derate the J package to 880 mW at 70°C at the rate of 11 mW/°C and derate the N package to 736 mW at 70°C at the rate of 9.2 mW/°C. In the J package, SN75160A chips are alloy-mounted.

recommended operating conditions

		MIN	NOM	MAX	UNIT
Supply voltage, $V_{CC}$		4.75	5	5.25	V
High-level output current, $I_{OH}$	Bus ports with pull-ups active			-5.2	mA
	Terminal ports			-800	μA
Low-level output current, $I_{OL}$	Bus ports			48	mA
	Terminal ports			16	
Operating free-air temperature, $T_A$		0		70	°C

# TYPE SN75160A

## OCTAL GENERAL-PURPOSE INTERFACE BUS TRANSCEIVER

electrical characteristics over recommended ranges of supply voltage and operating free-air temperature (unless otherwise noted)

PARAMETER		TEST CONDITIONS		MIN	TYP <sup>†</sup>	MAX	UNIT
V <sub>IH</sub>	High-level input voltage			2			V
V <sub>IL</sub>	Low-level input voltage					0.8	V
V <sub>IK</sub>	Input clamp voltage		I <sub>I</sub> = -18 mA		-0.8	-1.5	V
V <sub>T+</sub> - V <sub>T-</sub>	Hysteresis <sup>‡</sup>	Bus		0.4	0.65		V
V <sub>OH</sub>	High level output voltage	Terminal	I <sub>OH</sub> = -800 μA, TE at 0.8 V	2.7	3.5		V
		Bus	I <sub>OH</sub> = -5.2 mA, PE and TE at 2 V	2.5	3.3		
V <sub>OL</sub>	Low-level output voltage	Terminal	I <sub>OL</sub> = 16 mA, TE at 0.8 V		0.3	0.5	V
		Bus	I <sub>OL</sub> = 48 mA, TE at 2 V		0.4	0.5	
I <sub>I</sub>	Input current at maximum input voltage	Terminal	V <sub>I</sub> = 5.5 V		0.2	100	μA
I <sub>IH</sub>	High-level input current	Terminal	V <sub>I</sub> = 2.7 V		0.1	20	μA
I <sub>IL</sub>	Low-level input current	Terminal	V <sub>I</sub> = 0.5 V		-10	-100	μA
V <sub>I/O(bus)</sub>	Voltage at bus port	Driver disabled	I <sub>I(bus)</sub> = 0 I <sub>I(bus)</sub> = -12 mA	2.5	3.0	3.7 -1.5	V
I <sub>I/O(bus)</sub>	Current into bus port	Power on	Driver disabled	V <sub>I(bus)</sub> = -1.5 V to 0.4 V	-1.3		
				V <sub>I(bus)</sub> = 0.4 V to 2.5 V	0	-3.2	
				V <sub>I(bus)</sub> = 2.5 V to 3.7 V		+2.5 -3.2	
				V <sub>I(bus)</sub> = 3.7 V to 5 V	0	2.5	
				V <sub>I(bus)</sub> = 5 V to 5.5 V	0.7	2.5	
		Power off	V <sub>CC</sub> = 0, V <sub>I(bus)</sub> = 0 V to 2.5 V		-40		μA
I <sub>OS</sub>	Short-circuit output current	Terminal		-15	-35	-75	mA
		Bus		-25	-50	-125	
I <sub>CC</sub>	Supply current	No load	Receivers low and enabled	60	80		mA
			Drivers low and enabled	75	100		
C <sub>i/o(bus)</sub>	Bus-port capacitance		V <sub>CC</sub> = 5 V or 0 V, V <sub>I/O</sub> = 0 to 2 V, f = 1 MHz		30		pF

<sup>†</sup>All typical values are at V<sub>CC</sub> = 5, T<sub>A</sub> = 25°C.

<sup>‡</sup>Hysteresis is the difference between the positive-going input threshold voltage, V<sub>T+</sub>, and the negative-going input threshold voltage, V<sub>T-</sub>. See Figure 8.

switching characteristics, V<sub>CC</sub> = 5 V, C<sub>L</sub> = 15 pF, T<sub>A</sub> = 25°C (unless otherwise noted)

PARAMETER	FROM	TO	TEST CONDITIONS	MIN	TYP	MAX	UNIT
t <sub>PLH</sub>	Terminal	Bus	C <sub>L</sub> = 30 pF, R <sub>L</sub> = 38.3 Ω to 2.3 V, See Figure 1		14	20	ns
t <sub>PHL</sub>					14	20	
t <sub>PLH</sub>	Bus	Terminal	C <sub>L</sub> = 30 pF, R <sub>L</sub> = 240 Ω to 5 V, See Figure 2		12	20	ns
t <sub>PHL</sub>					16	22	
t <sub>PZH</sub>	TE	Bus	R <sub>L</sub> = 480 Ω to 0 V, See Figure 3		25	35	ns
t <sub>PHZ</sub>					13	22	
t <sub>PZL</sub>					22	35	
t <sub>PLZ</sub>					22	32	
t <sub>PZH</sub>	TE	Terminal	R <sub>L</sub> = 3 kΩ to 0 V, See Figure 4		20	30	ns
t <sub>PHZ</sub>					12	20	
t <sub>PZL</sub>					23	32	
t <sub>PLZ</sub>					19	30	
t <sub>en</sub>	PE	Bus	R <sub>L</sub> = 480 Ω to 0 V, See Figure 5		15	22	ns
t <sub>djs</sub>					13	20	

**TEXAS INSTRUMENTS**  
INCORPORATED

POST OFFICE BOX 225012 • DALLAS, TEXAS 75265

# TYPE SN75160A OCTAL GENERAL-PURPOSE INTERFACE BUS TRANSCEIVER

## PARAMETER MEASUREMENT INFORMATION

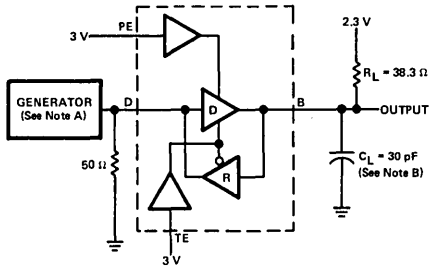

TEST CIRCUIT

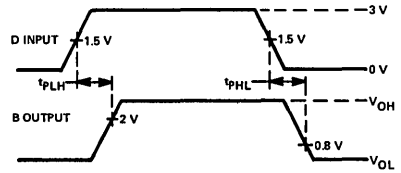

VOLTAGE WAVEFORMS

FIGURE 1—TERMINAL-TO-BUS PROPAGATION DELAY TIMES

5

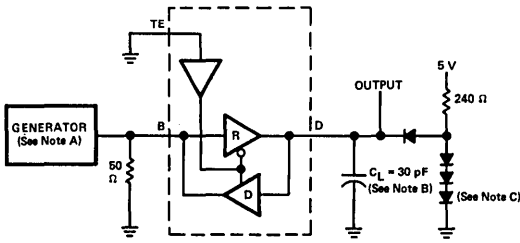

TEST CIRCUIT

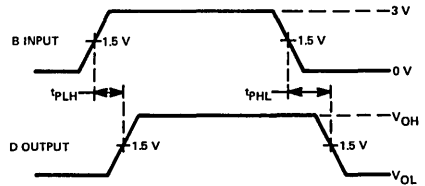

VOLTAGE WAVEFORMS

FIGURE 2—BUS-TO-TERMINAL PROPAGATION DELAY TIMES

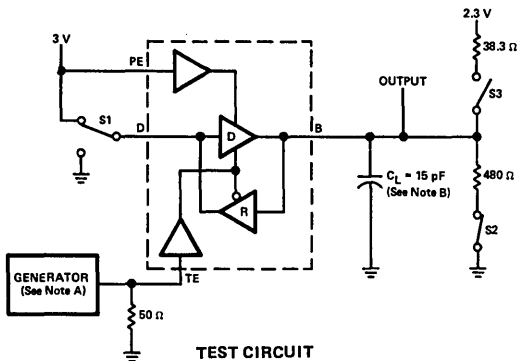

TEST CIRCUIT

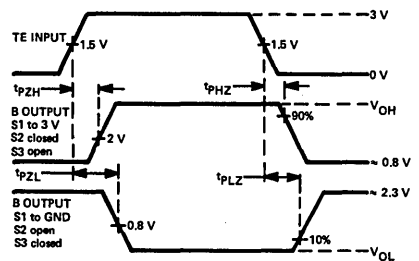

VOLTAGE WAVEFORMS

FIGURE 3—TE-TO-BUS ENABLE AND DISABLE TIMES

- NOTES: A. The input pulse is supplied by a generator having the following characteristics: PRR = 1 MHz, 50% duty cycle,  $t_r \leq 6$  ns,  $t_f \leq 6$  ns,  $Z_{out} = 50 \Omega$ .  
 B.  $C_L$  includes probe and jig capacitance.  
 C. All diodes are 1N916 or equivalent.

# TYPE SN75160A

## OCTAL GENERAL-PURPOSE INTERFACE BUS TRANSCEIVER

### PARAMETER MEASUREMENT INFORMATION

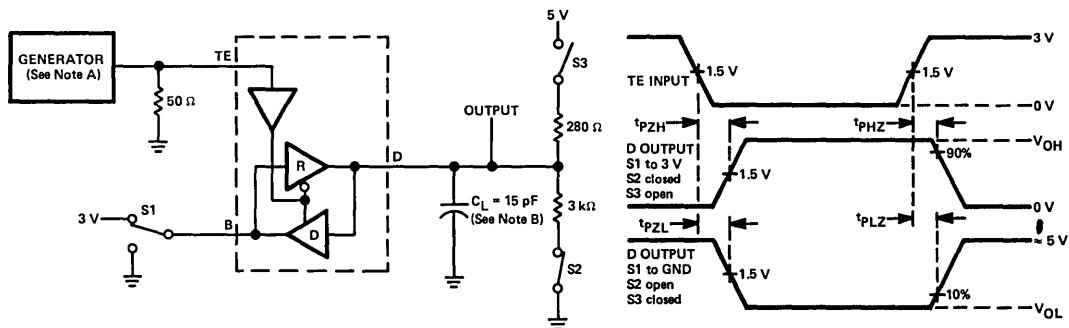

**TEST CIRCUIT** **VOLTAGE WAVEFORMS**  
**FIGURE 4—TE-TO-TERMINAL ENABLE AND DISABLE TIMES**

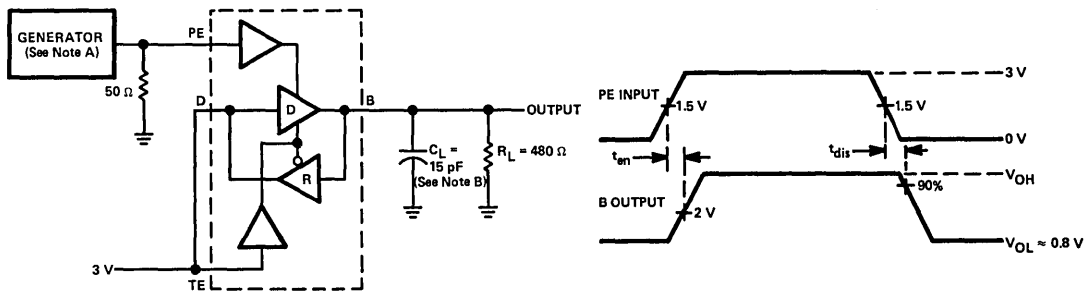

**TEST CIRCUIT** **VOLTAGE WAVEFORMS**  
**FIGURE 5—PE-TO-BUS PULL-UP ENABLE AND DISABLE TIMES**

NOTES: A. The input pulse is supplied by a generator having the following characteristics: PRR = 1 MHz, 50% duty cycle,  $t_r \leq 6$  ns,  $t_f \leq 6$  ns,  $Z_{out} = 50 \Omega$ .  
 B.  $C_L$  includes probe and jig capacitance.

### TYPICAL CHARACTERISTICS

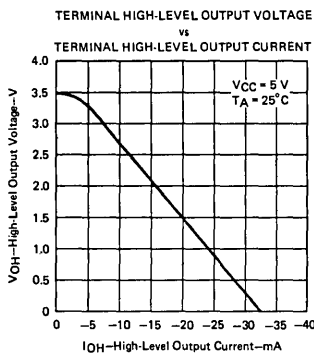

**FIGURE 6**

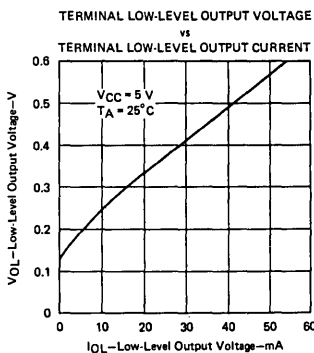

**FIGURE 7**

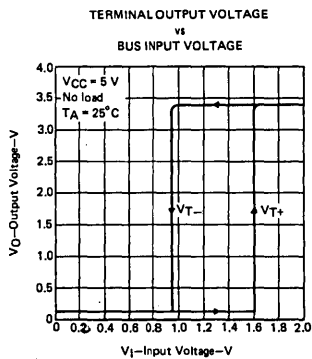

**FIGURE 8**

**TEXAS INSTRUMENTS**  
 INCORPORATED

POST OFFICE BOX 225012 • DALLAS, TEXAS 75265

# TYPE SN75160A

## OCTAL GENERAL-PURPOSE INTERFACE BUS TRANSCEIVER

### TYPICAL CHARACTERISTICS

BUS HIGH-LEVEL OUTPUT VOLTAGE  
vs  
BUS HIGH-LEVEL OUTPUT CURRENT

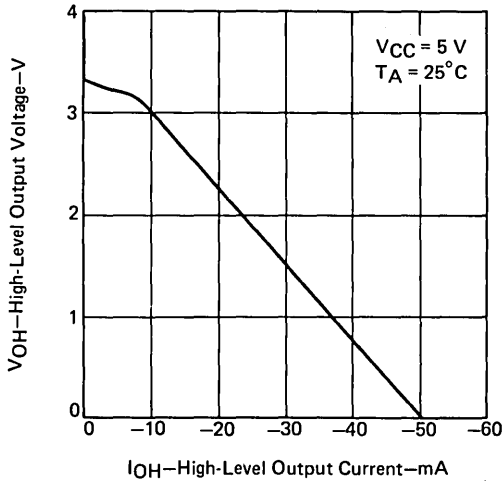

FIGURE 9

BUS LOW-LEVEL OUTPUT VOLTAGE  
vs  
BUS LOW-LEVEL OUTPUT CURRENT

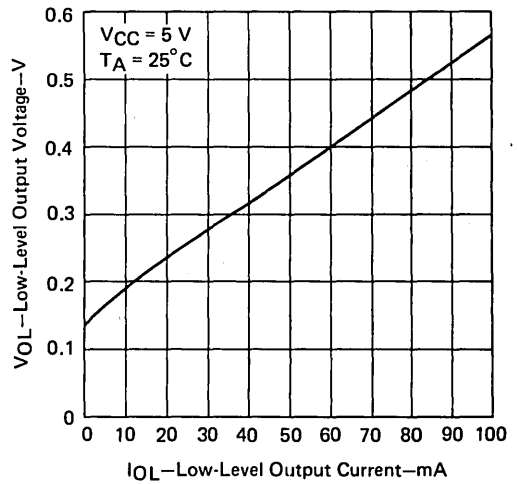

FIGURE 10

BUS OUTPUT VOLTAGE  
vs  
TERMINAL INPUT VOLTAGE

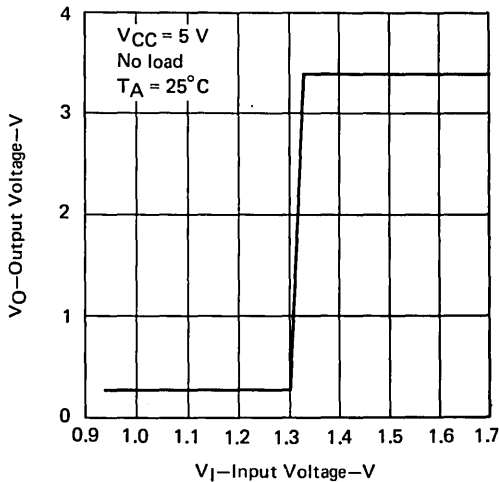

FIGURE 11

BUS CURRENT  
vs  
BUS VOLTAGE

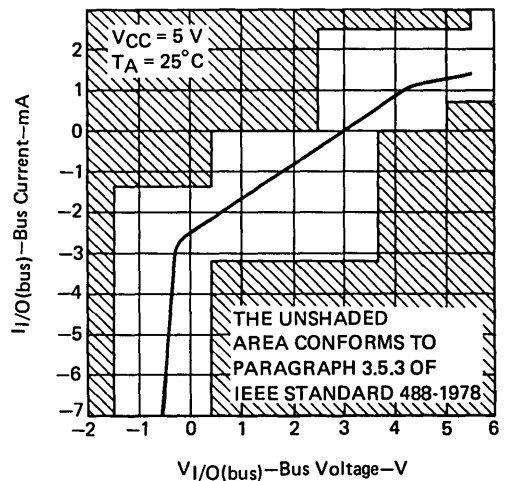

FIGURE 12



# INTERFACE CIRCUITS

# TYPES SN75161A, SN75162A OCTAL GENERAL-PURPOSE INTERFACE BUS TRANSCEIVERS

BULLETIN NO. DL-S 12787, OCTOBER 1980

MEETS IEEE STANDARD 488-1978 ( GPIB )

- 8-Channel Bidirectional Transceiver
- Designed to Implement Control Bus Interface
- SN75161A Designed for Single Controller
- SN75162A Designed for Multi-Controllers
- High-Speed, Low-Power Schottky Circuitry†
- Low Power Dissipation . . . 65 mW Max Per Channel
- Fast Propagation Times . . . 22 ns Max
- High-Impedance P-N-P Inputs
- Receiver Hysteresis . . . 650 mV Typ
- Bus-Terminating Resistors Provided on Driver Outputs
- No Loading of Bus when Device is Powered Down ( $V_{CC} = 0V$ )

## description

The SN75161A and SN75162A eight-channel general-purpose interface bus transceivers are monolithic, high-speed, low-power Schottky devices designed to meet the requirements of IEEE Standard 488-1978. Each transceiver is designed to provide the bus-management and data-transfer signals between operating units of a single- or multiple-controller instrumentation system. When combined with the SN75160A octal bus transceiver, the SN75161A or SN75162A provides the complete 16-wire interface for the IEEE 488 bus.

The SN75161A and SN75162A each features eight driver-receiver pairs connected in a front-to-back configuration to form input/output (I/O) ports at both the bus and terminal sides. The direction of data through these driver-receiver pairs is determined by the DC, TE, and SC (on SN75162A) enable signals. The SC input on the SN75162A allows the REN and IFC transceivers to be controlled independently.

The driver outputs ( GPIB I/O ports ) feature active bus-terminating resistor circuits designed to provide a high-impedance to the bus when  $V_{CC} = 0$  volts. The drivers are designed to handle loads up to 48 milliamperes of sink current. Each receiver features p-n-p transistor inputs for high-input impedance and a guaranteed hysteresis of 400 millivolts for increased noise immunity. All receivers have 3-state outputs to present a high-impedance to the terminal when disabled.

The SN75161A is manufactured in a 20-pin dual-in-line package. The SN75162A is manufactured in a 22-pin 400-mil (10,2-mm) dual-in-line package. The SN75161A and SN75162A are characterized for operation from 0°C to 70°C.

SN75161A . . . J or N  
DUAL-IN-LINE PACKAGE  
(TOP VIEW)

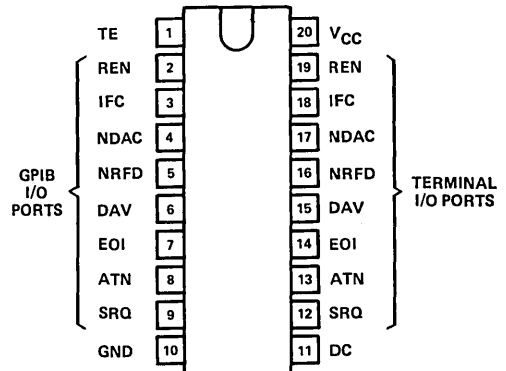

SN75162A . . . J OR N  
DUAL-IN-LINE PACKAGE  
(TOP VIEW)

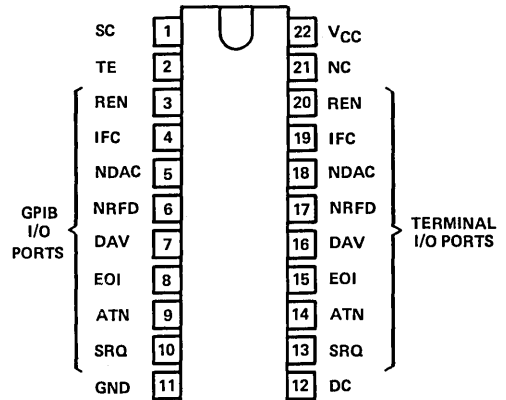

NC = No internal connection

TABLE OF ABBREVIATIONS

NAME	IDENTITY	CLASS
DC	Direction Control	Control
TE	Talk Enable	
SC	System Control (SN75162 only)	
ATN	Attention	Bus Management
SRQ	Service Request	
REN	Remote Enable	
IFC	Interface Clear	
EOI	End or Identify	Data Transfer
DAV	Data Valid	
NDAC	Not Data Accepted	
NRFD	Not Ready for Data	

Copyright © 1980 by Texas Instruments Incorporated

TEXAS INSTRUMENTS  
INCORPORATED

POST OFFICE BOX 225012 • DALLAS, TEXAS 75265

†Integrated Schottky-Barrier diode-clamped transistor is patented by Texas Instruments. U.S. Patent Number 3,463,975. 5-177

# TYPES SN75161A, SN75162A OCTAL GENERAL-PURPOSE INTERFACE BUS TRANSCEIVERS

logic symbols†

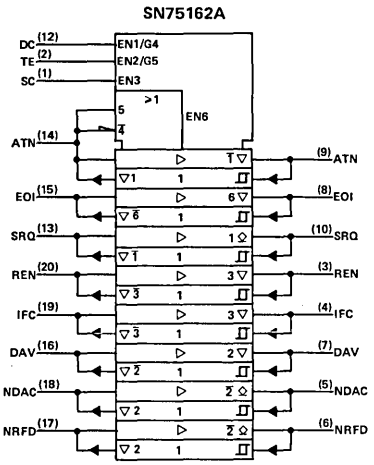
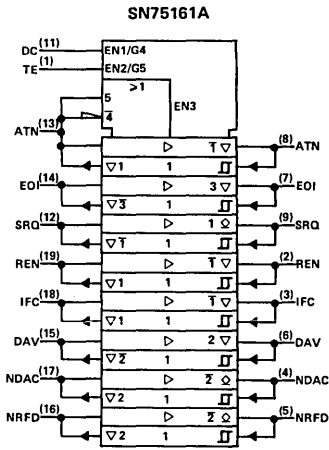

▽ designates 3-state output, ◻ designates open-collector outputs.

† These symbols are in accordance with IEEE Std 91/ANSI Y32.14 and current discussions in IEC and IEEE.

functional block diagrams (positive logic)

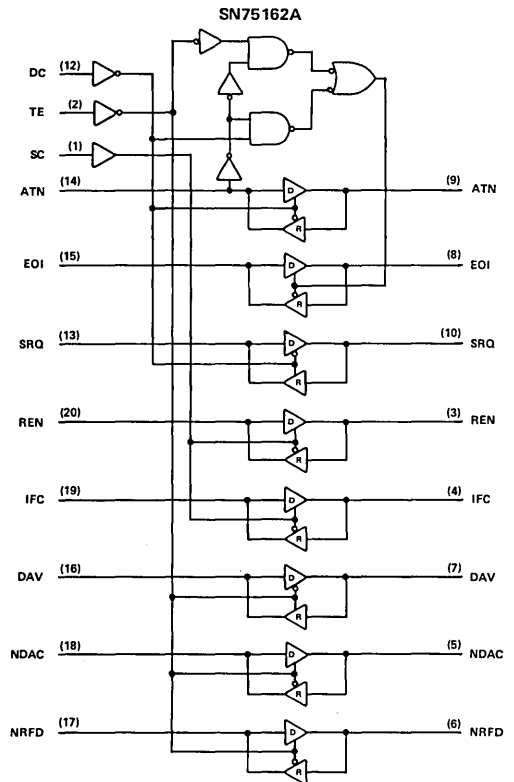
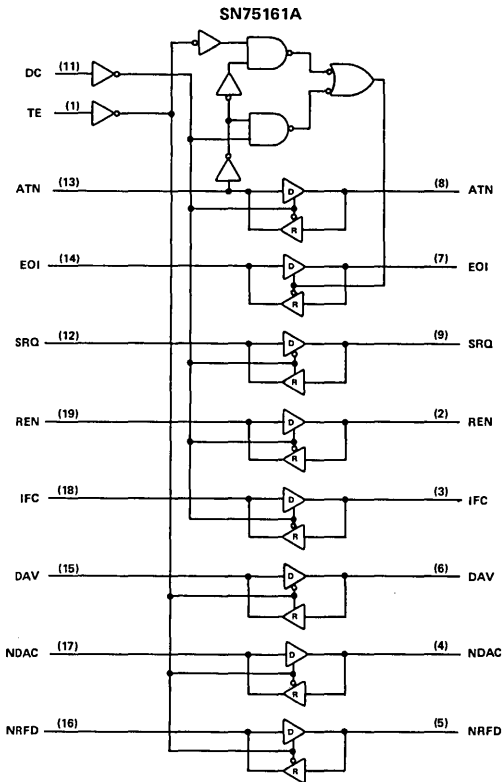

# TYPES SN75161 A, SN75162A OCTAL GENERAL-PURPOSE INTERFACE BUS TRANSCEIVERS

SN75161A

RECEIVE/TRANSMIT FUNCTION TABLE

CONTROLS			BUS-MANAGEMENT CHANNELS				DATA-TRANSFER CHANNELS			
DC	TE	ATN <sup>†</sup>	ATN <sup>†</sup>	SRQ (Controlled by DC)	REN	IFC	EOI	DAV	NDAC	NRFD (Controlled by TE)
H	H	H	R	T	R	R	T	T	R	R
H	H	L	R	T	R	R	R	T	R	R
L	L	H	T	R	T	T	R	R	T	T
L	L	L	T	R	T	T	T	R	T	T
H	L	X	R	T	R	R	R	R	T	T
L	H	X	T	R	T	T	T	T	R	R

SN75162A

RECEIVE/TRANSMIT FUNCTION TABLE

CONTROLS				BUS-MANAGEMENT CHANNELS				DATA-TRANSFER CHANNELS				
SC	DC	TE	ATN <sup>†</sup>	ATN <sup>†</sup> (Controlled by DC)	SRQ	REN (Controlled by SC)	IFC	EOI	DAV	NDAC	NRFD (Controlled by TE)	
	H	H	H	R	T			T	T	R	R	
	H	H	L	R	T			R	R	R	R	
	L	L	H	T	R			T	R	R	T	T
	L	L	L	T	R			T	T	R	T	T
	H	L	X	R	T			T	R	R	T	T
	L	H	X	T	R			T	T	T	T	R
H						T	T					
L						R	R					

H = high level, L = Low level, R = receive, T = transmit, X = Irrelevant

Direction of data transmission is from the terminal side to the bus side, and the direction of data receiving is from the bus side to the terminal side. Data transfer is noninverting in both directions.

†ATN is a normal transceiver channel that functions additionally as an internal direction control or talk enable for EOI whenever the DC and TE inputs are in the same state. When DC and TE are in opposite states, the ATN channel functions as an independent transceiver only.

## schematics of inputs and outputs

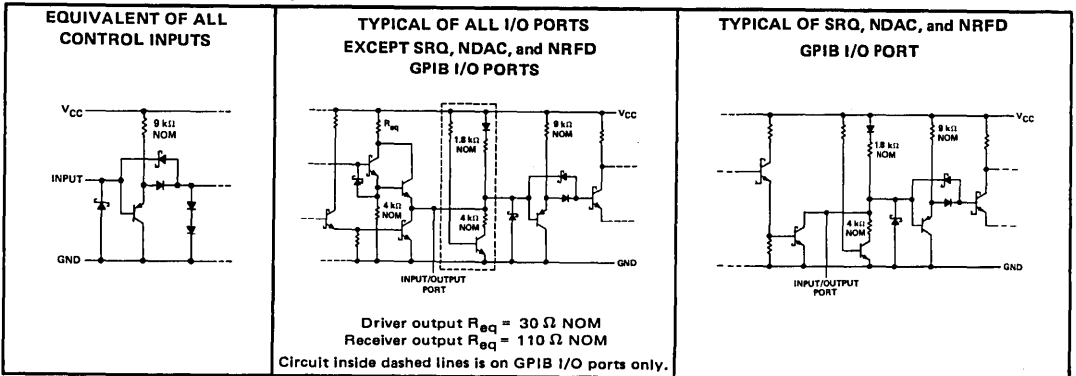

5

# TYPES SN75161A, SN75162A

## OCTAL GENERAL-PURPOSE INTERFACE BUS TRANSCEIVERS

absolute maximum ratings over operating free-air temperature range (unless otherwise noted)

Supply voltage, $V_{CC}$ (See Note 1)	7 V
Input voltage	5.5 V
Low-level driver output current	100 mA
Continuous total dissipation at (or below) 25°C free-air temperature (see Note 2): J Package	1375 mW
N Package	1150 mW
Operating free-air temperature range	0°C to 70°C
Storage temperature range	-65°C to 150°C
Lead temperature 1/16 inch (1,6 mm) from case for 10 seconds	260°C

NOTES: 1. All voltage values are with respect to network ground terminal.  
 2. For operation above 25°C free-air temperature, derate the J package to 880 mW at 70°C at the rate of 11 mW/°C and derate the N package to 736 mW at 70°C at the rate of 9.2 mW/°C. In the J package, SN75161A and SN75162A chips are alloy-mounted.

recommended operating conditions

	MIN	NOM	MAX	UNIT
Supply voltage, $V_{CC}$	4.75	5	5.25	V
High-level output current, $I_{OH}$	Bus ports with 3-state outputs			-5.2 mA
	Terminal ports			-800 $\mu$ A
Low-level output current, $I_{OL}$	Bus ports			48 mA
	Terminal ports			16 mA
Operating free-air temperature, $T_A$	0	70		°C

electrical characteristics over recommended ranges of supply voltage and operating free-air temperature (unless otherwise noted)

PARAMETER		TEST CONDITIONS		MIN	TYP†	MAX	UNIT
$V_{IH}$	High-level input voltage			2			V
$V_{IL}$	Low-level input voltage					0.8	V
$V_{IK}$	Input clamp voltage		$I_I = -18$ mA	-0.8		-1.5	V
$V_{T+} - V_{T-}$	Hysteresis		Bus	0.4	0.65		V
$V_{OH}$	High-level output voltage	Terminal	$I_{OH} = -800$ $\mu$ A	2.7	3.5		V
		Bus	$I_{OH} = -5.2$ mA	2.5	3.3		
$V_{OL}$	Low-level output voltage	Terminal	$I_{OL} = 16$ mA	0.3	0.5		V
		Bus	$I_{OL} = 48$ mA	0.35	0.5		
$I_I$	Input current at maximum input voltage	Terminal	$V_I = 5.5$ V	0.2	100		$\mu$ A
$I_{IH}$	High-level input current	Terminal and control inputs	$V_I = 2.7$ V	0.1	20		$\mu$ A
$I_{IL}$	Low-level input current	Terminal and control inputs	$V_I = 0.5$ V	-10	-100		$\mu$ A
$V(I/O)_{(bus)}$	Voltage at bus port	Driver disabled	$I_I(bus) = 0$	2.5	3.0	3.7	V
			$I_I(bus) = -12$ mA			-1.5	
$I_I/O(bus)$	Current into bus port	Power on	Driver disabled	$V_I(bus) = -1.5$ V to 0.4 V		-1.3	mA
				$V_I(bus) = 0.4$ to 2.5 V		0	
				$V_I(bus) = 2.5$ V to 3.7 V		+2.5	
				$V_I(bus) = 3.7$ V to 5 V		0	
				$V_I(bus) = 5$ V to 5.5 V		0.7	
		$V_I(bus) = 5$ V to 5.5 V		2.5			
		Power off	$V_{CC} = 0$ , $V_I(bus) = 0$ V to 2.5 V			-40	$\mu$ A
$I_{OS}$	Short-circuit output current	Terminal		-15	-35	-75	mA
		Bus		-25	-50	-125	
$I_{CC}$	Supply current		No load, TE, DC, and SC low			100	mA
$C_{i/o}(bus)$	Bus-port capacitance		$V_{CC} = 5$ V or 0 V, $V_I/O = 0$ to 2 V, $f = 1$ MHz		30		pF

† All typical values are at  $V_{CC} = 5$  V,  $T_A = 25^\circ$ C

# TYPES SN75161A, SN75162A OCTAL GENERAL-PURPOSE INTERFACE BUS TRANSCEIVERS

switching characteristics,  $V_{CC} = 5\text{ V}$ ,  $C_L = 15\text{ pF}$ ,  $T_A = 25^\circ\text{C}$  (unless otherwise noted)

PARAMETER	FROM	TO	TEST CONDITIONS	MIN	TYP	MAX	UNIT
$t_{PLH}$ Propagation delay time, low-to-high-level output	Terminal	Bus	$C_L = 30\text{ pF}$ , $R_L = 38.3\ \Omega$ to 2.3 V, See Figure 1	14	20	ns	
$t_{PHL}$ Propagation delay time, high-to-low-level output				14	20		
$t_{PLH}$ Propagation delay time, low-to-high-level output	Bus	Terminal	$C_L = 30\text{ pF}$ , $R_L = 240\ \Omega$ to 5 V, See Figure 2	12	20	ns	
$t_{PHL}$ Propagation delay time, high-to-low-level output				16	22		
$t_{PZH}$ Output enable time to high level	TE, DC, or SC	BUS (ATTN, EOI, REN, IFC, and DAV)	$R_L = 480\ \Omega$ to 0 V, See Figure 3	60	ns		
$t_{PHZ}$ Output disable time from high level				45			
$t_{PZL}$ Output enable time to low level				60			
$t_{PLZ}$ Output disable time from low level				55			
$t_{PZH}$ Output enable time to high level	TE, DC, or SC	Terminal	$R_L = 3\text{ k}\Omega$ to 0 V, See Figure 4	55	ns		
$t_{PHZ}$ Output disable time from high level				50			
$t_{PZL}$ Output enable time to low level				45			
$t_{PLZ}$ Output disable time from low level				55			

5

## PARAMETER MEASUREMENT INFORMATION

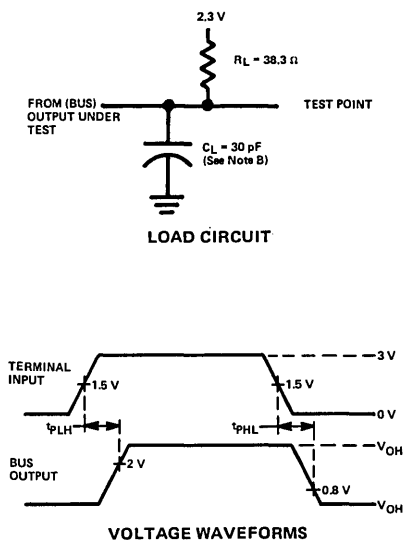

**FIGURE 1 — TERMINAL-TO-BUS PROPAGATION DELAY TIMES**

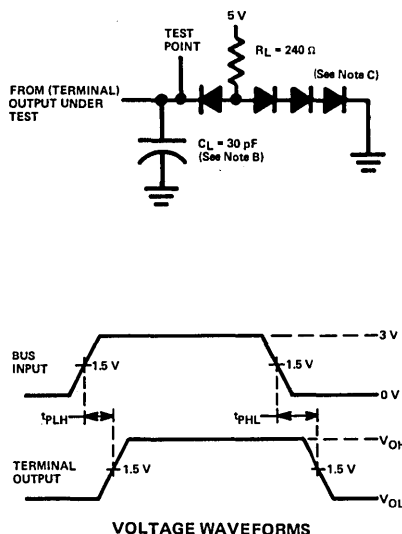

**FIGURE 2 — BUS-TO-TERMINAL PROPAGATION DELAY TIMES**

- NOTES: A. The input pulse is supplied by a generator having the following characteristics: PRR = 1 MHz, 50% duty cycle,  $t_r \leq 6\text{ ns}$ ,  $t_f \leq 6\text{ ns}$ ,  $Z_{out} = 50\ \Omega$ .  
 B.  $C_L$  includes probe and jig capacitance.  
 C. All diodes are 1N916 or equivalent.

# TYPES SN75161A, SN75162A OCTAL GENERAL-PURPOSE INTERFACE BUS TRANSCEIVERS

## PARAMETER MEASUREMENT INFORMATION

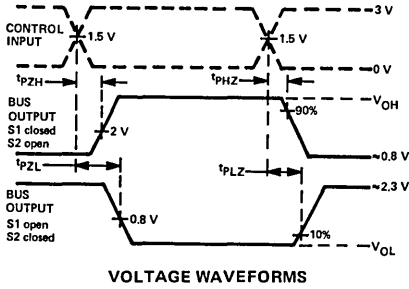
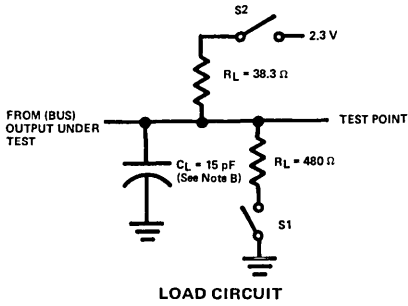

FIGURE 3 — BUS ENABLE AND DISABLE TIMES

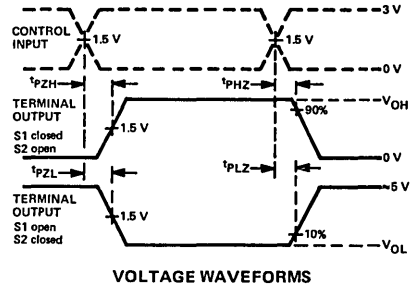
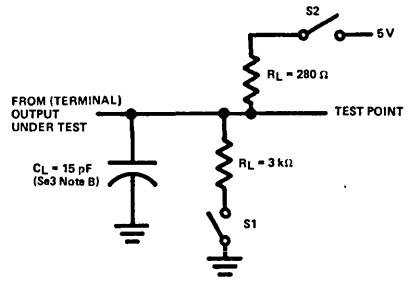
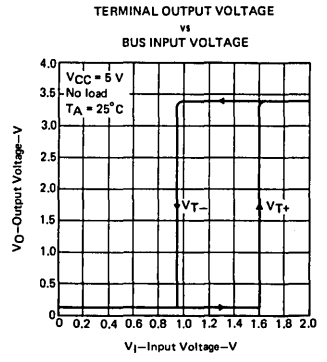
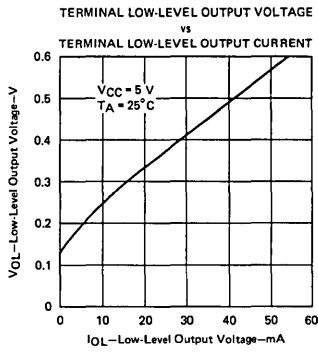
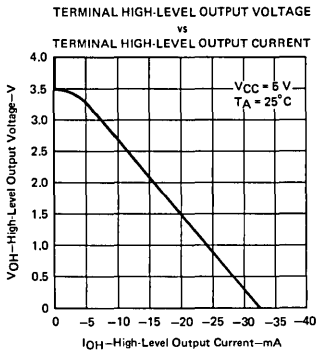

FIGURE 4 — TERMINAL ENABLE AND DISABLE TIMES

NOTES: A. The input pulse is supplied by a generator having the following characteristics: PRR = 1 MHz, duty cycle = 50%,  $t_r < 6 \text{ ns}$ ,  $t_f < 6 \text{ ns}$ ,  $Z_{out} = 50 \Omega$ .  
B.  $C_L$  includes probe and jig capacitance.

## TYPICAL CHARACTERISTICS



# TYPES SN75161A, SN75162A OCTAL GENERAL-PURPOSE INTERFACE BUS TRANSCEIVERS

## TYPICAL CHARACTERISTICS

BUS HIGH-LEVEL OUTPUT VOLTAGE  
vs  
BUS HIGH-LEVEL OUTPUT CURRENT

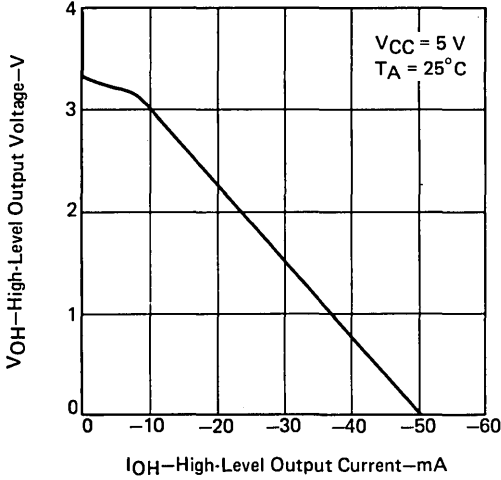

FIGURE 4

BUS LOW-LEVEL OUTPUT VOLTAGE  
vs  
BUS LOW-LEVEL OUTPUT CURRENT

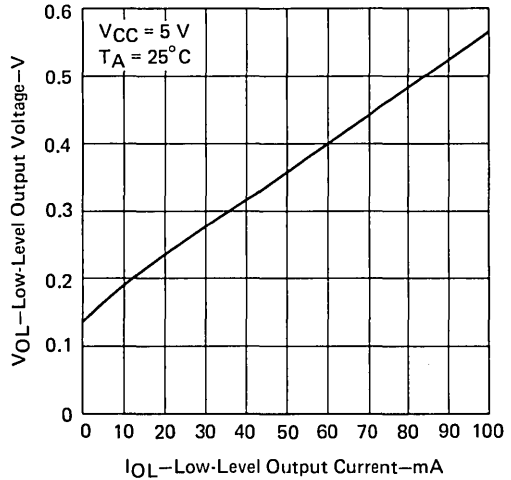

FIGURE 5

BUS OUTPUT VOLTAGE  
vs  
TERMINAL INPUT VOLTAGE

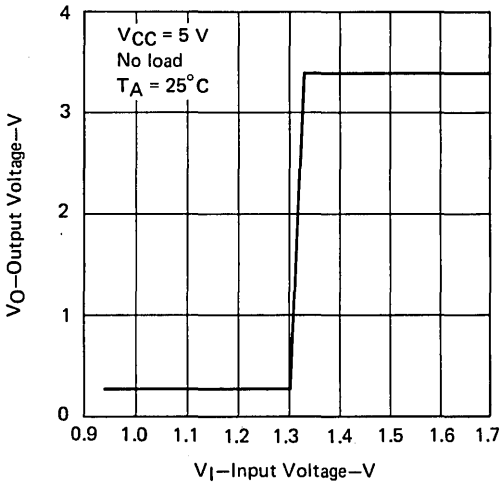

FIGURE 6

BUS CURRENT  
vs  
BUS VOLTAGE

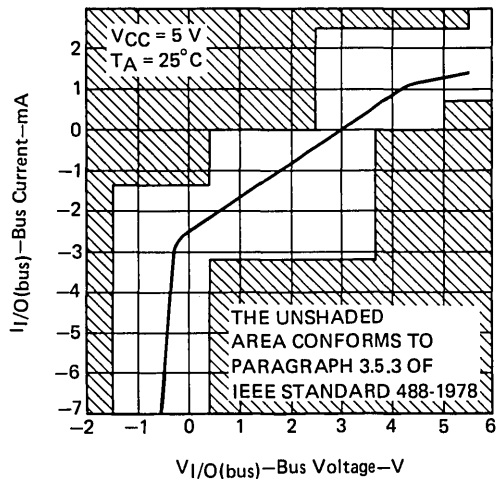

FIGURE 7

TEXAS INSTRUMENTS  
INCORPORATED

POST OFFICE BOX 225012 • DALLAS, TEXAS 75265

# INTERFACE CIRCUITS

# TYPE SN75163A OCTAL GENERAL-PURPOSE INTERFACE BUS TRANSCEIVER

BULLETIN NO. DL-S 12778, OCTOBER 1980

- 8-Channel Bidirectional Transceivers
- High-Speed Low-Power Schottky Circuitry†
- Low Power Dissipation . . . 60 mW Max per Channel
- High-Impedance P-N-P Inputs
- Receiver Hysteresis . . . 650 mV Typ
- Open-Collector Driver Output Option
- No Loading of Bus When Device is Powered Down ( $V_{CC} = 0 V$ )

### description

The SN75163A octal general-purpose interface bus transceiver is a monolithic, high-speed, low-power Schottky device. It is designed for two-way data communications over single-ended transmission lines. The transceiver features driver outputs that can be operated in either the open-collector or three-state modes. If Talk Enable is high, these outputs have the characteristics of open-collector outputs when Pull-up Enable (PE) is low and of three-state outputs when PE is high. Taking TE low places the outputs in the high-impedance state. The driver outputs are designed to handle loads up to 48 milliamperes of sink current. Each receiver features p-n-p transistor inputs for high input impedance and 400 millivolts of guaranteed hysteresis for increased noise immunity.

The SN75163 is characterized for operation from 0°C to 70°C.

### logic symbol‡

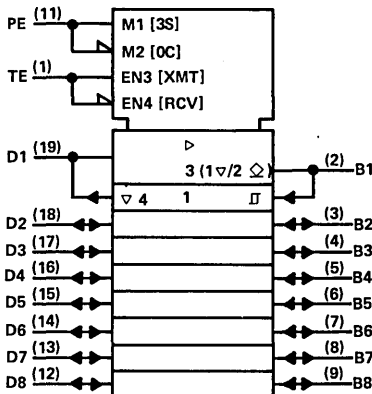

‡ This symbol is in accordance with IEEE Std 91/ANSI Y32.14 and current discussions in IEC and IEEE.

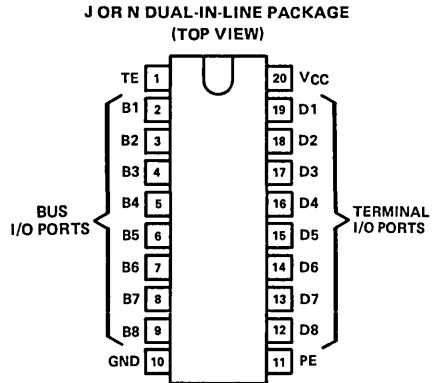

### FUNCTION TABLES

#### DRIVERS

INPUTS			OUTPUT
D	TE	PE	B
H	H	H	H
L	H	H	L
H	X	L	Z
L	H	L	L
X	L	X	Z

#### RECEIVERS

INPUTS			OUTPUTS
B	TE	PE	D
L	L	X	L
H	L	X	H
X	H	X	Z

H = high level, L = low level, X = Irrelevant, Z = High-impedance state.

### functional block diagram (positive logic)

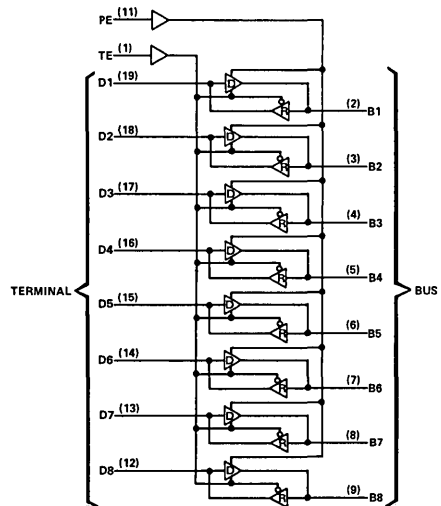

Copyright © 1980 by Texas Instruments Incorporated



# TYPE SN75163A

## OCTAL GENERAL-PURPOSE INTERFACE BUS TRANSCEIVER

### schematics of inputs and outputs

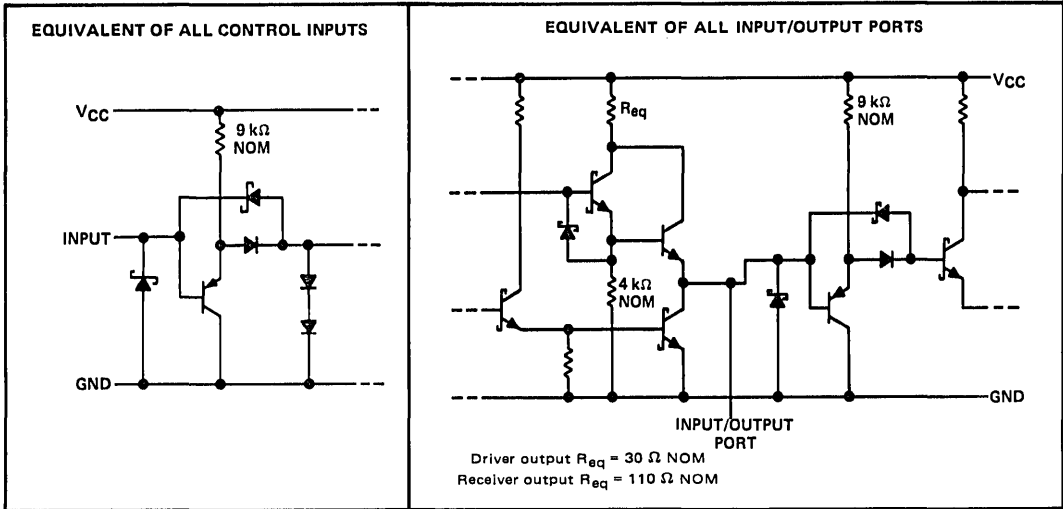

5

### absolute maximum ratings over operating free-air temperature range (unless otherwise noted)

Supply voltage, $V_{CC}$ (see Note 1)	7 V
Input voltage	5.5 V
Low-level driver output current	100 mA
Continuous total dissipation at (or below) 25°C free-air temperature (see Note 2): J package	1375 mW
N package	1150 mW
Operating free-air temperature range	0°C to 70°C
Storage temperature range	-65°C to 150°C
Lead temperature 1/16 (1,6 mm) from case for 10 seconds	260°C

- NOTES: 1. All voltage values are with respect to network ground terminal.  
 2. For operation above 25°C free-air temperature, derate the J package to 880 mW at 70°C at the rate of 11 mW/°C and derate the N package to 736 mW at 70°C at the rate of 9.2 mW/°C. In the J package, SN75163A chips are alloy-mounted.

### recommended operating conditions

		MIN	NOM	MAX	UNIT
Supply voltage, $V_{CC}$		4.75	5	5.25	V
High-level output current, $I_{OH}$	Bus ports with pull-ups active			-10	mA
	Terminal ports			-800	μA
Low-level output current, $I_{OL}$	Bus ports			48	mA
	Terminal ports			16	mA
Operating free-air temperature, $T_A$		0		70	°C

# TYPE SN75163A

## OCTAL GENERAL-PURPOSE INTERFACE BUS TRANSCEIVER

electrical characteristics over recommended ranges of supply voltage and operating free-air temperature (unless otherwise noted)

PARAMETER		TEST CONDITIONS		MIN	TYP†	MAX	UNIT
V <sub>IH</sub>	High-level input voltage			2			V
V <sub>IL</sub>	Low-level input voltage					0.8	V
V <sub>IK</sub>	Input clamp voltage	I <sub>I</sub> = -18 mA			-0.8	-1.5	V
V <sub>T+</sub> - V <sub>T-</sub>	Hysteresis‡	Bus		0.4	0.65		V
V <sub>OH</sub>	High level output voltage	Terminal	I <sub>OH</sub> = -800 μA, TE at 0.8 V	2.7	3.5		V
		Bus	I <sub>OH</sub> = -10 mA, PE and TE at 2 V	2.5	3.3		
V <sub>OL</sub>	Low-level output voltage	Terminal	I <sub>OL</sub> = 16 mA, TE at 0.8 V		0.3	0.5	V
		Bus	I <sub>OL</sub> = 48 mA, PE and TE at 2 V		0.4	0.5	
I <sub>OH</sub>	High-level output current (open-collector mode)	Bus	V <sub>O</sub> = 5.5 V, PE at 0.8 V, D and TE at 2 V			100	μA
I <sub>OZ</sub>	Off-state output current (3-state mode)	Bus	PE at 2 V, V <sub>O</sub> = 2.7 V			20	μA
			TE at 0.8 V, V <sub>O</sub> = 0.4 V			-20	
I <sub>I</sub>	Input current at maximum input voltage	Terminal	V <sub>I</sub> = 5.5 V		0.2	100	μA
I <sub>IH</sub>	High-level input current	Terminal	V <sub>I</sub> = 2.7 V		0.1	20	μA
I <sub>IL</sub>	Low-level input current	Terminal	V <sub>I</sub> = 0.5 V		-10	-100	μA
I <sub>OS</sub>	Short-circuit output current	Terminal		-15	-35	-75	mA
		Bus		-25	-50	-125	
I <sub>CC</sub>	Supply current	No load	Receivers low and enabled			70	mA
			Drivers low and enabled			90	
C <sub>i/o(bus)</sub>	Bus-port capacitance	V <sub>CC</sub> = 5 V or 0 V, V <sub>I/O</sub> = 0 to 2 V, f = 1 MHz			30		pF

† All typical values are at V<sub>CC</sub> = 5, T<sub>A</sub> = 25°C.

‡ Hysteresis is the difference between the positive-going input threshold voltage, V<sub>T+</sub>, and the negative-going input threshold voltage, V<sub>T-</sub>.

switching characteristics, V<sub>CC</sub> = 5 V, C<sub>L</sub> = 15 pF, T<sub>A</sub> = 25°C (unless otherwise noted)

PARAMETER		FROM	TO	TEST CONDITIONS		MIN	TYP	MAX	UNIT
t <sub>PLH</sub>	Propagation delay time, low-to-high-level output	Terminal	Bus	C <sub>L</sub> = 30 pF, R <sub>L</sub> = 38.3 Ω to 2.3 V			14	20	ns
t <sub>PHL</sub>	Propagation delay time, high-to-low-level output						14	20	
t <sub>PLH</sub>	Propagation delay time, low-to-high-level output	Bus	Terminal	C <sub>L</sub> = 30 pF, R <sub>L</sub> = 240 Ω to 5 V			12	20	ns
t <sub>PHL</sub>	Propagation delay time, high-to-low-level output						16	22	
t <sub>PZH</sub>	Output enable time to high level	TE	Bus	R <sub>L</sub> = 480 Ω to 0 V			25	35	ns
t <sub>PHZ</sub>	Output disable time from high level						13	22	
t <sub>PZL</sub>	Output enable time to low level						22	35	
t <sub>PLZ</sub>	Output disable time from low level						22	32	
t <sub>PZH</sub>	Output enable time to high level	TE	Terminal	R <sub>L</sub> = 3 kΩ to 0 V			20	30	ns
t <sub>PHZ</sub>	Output disable time from high level						12	20	
t <sub>PZL</sub>	Output enable time to low level						23	32	
t <sub>PLZ</sub>	Output disable time from low level						19	30	
t <sub>en</sub>	Output pull-up enable time	PE	Terminal	R <sub>L</sub> = 480 Ω to 0 V			15	22	ns
t <sub>dis</sub>	Output pull-up disable time						13	20	

For test circuits and voltage waveforms, see SN75160A, pages 5-174 and 5-175.

# INTERFACE CIRCUITS

# TYPE SN75172 QUADRUPLE DIFFERENTIAL LINE DRIVER

BULLETIN NO. DL-S 12769, OCTOBER 1980

- Meets EIA Standard RS-422A and CCITT Recommendations V.11 and X.27
- Meets EIA Subcommittee TR30.1 Draft Standard PN1360 (as of April 1980)
- Designed for Multipoint Transmission on Long Bus Lines in Noisy Environments
- 3-State Outputs
- Common-Mode Output Voltage Range . . . -7 V to 12 V
- Active-High and Active-Low Enables
- Thermal Shutdown Protection
- Positive and Negative Current Limiting
- Operates from Single 5-Volt Supply
- Low Power Requirements
- Functionally Interchangeable With AM26LS31

J OR N  
DUAL-IN-LINE PACKAGE (TOP VIEW)

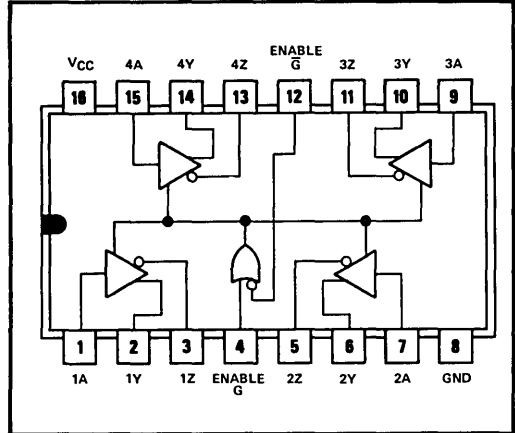

FUNCTION TABLE (EACH DRIVER)

INPUT A	ENABLES		OUTPUTS	
	G	$\bar{G}$	Y	Z
H	H	X	H	L
L	H	X	L	H
H	X	L	H	L
L	X	L	L	H
X	L	H	Z	Z

H = high level  
L = low level  
X = irrelevant  
Z = high impedance (off)

## description

The SN75172 is a monolithic quadruple differential line driver with three-state outputs. It is designed to meet the requirements of EIA Standard RS-422A and CCITT Recommendations V.11 and X.27. The device is optimized for balanced multipoint bus transmission at rates up to 4 megabits per second. Each driver features wide positive and negative common-mode output voltage ranges making it suitable for party-line applications in noisy environments.

The SN75172 provides positive- and negative-current limiting and thermal shutdown for protection from line fault conditions on the transmission-bus line. Shutdown occurs at a junction temperature of approximately 150°C. This device offers optimum performance when used with the SN75173 or SN75175 quadruple differential line receivers.

The SN75172 is characterized for operation from 0°C to 70°C.

## schematics of inputs and outputs

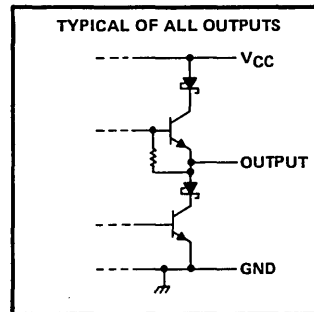
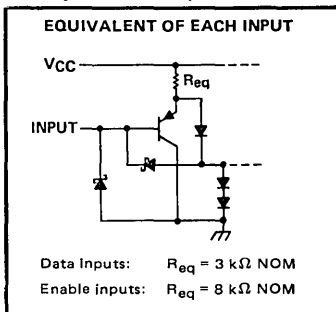

Copyright © 1980 by Texas Instruments Incorporated

TEXAS INSTRUMENTS  
INCORPORATED

POST OFFICE BOX 225012 • DALLAS, TEXAS 75265

# TYPE SN75172

## QUADRUPLE DIFFERENTIAL LINE DRIVER

### absolute maximum ratings over operating free-air temperature range (unless otherwise noted)

Supply voltage, $V_{CC}$ (see Note 1)	7 V
Input voltage	5.5 V
Continuous total dissipation at (or below) 25°C free-air temperature (see Note 2): J package	1375 mW
N package	1150 mW
Operating free-air temperature range	0°C to 70°C
Storage temperature range	-65°C to 150°C
Lead temperature 1/16 inch (1,6 mm) from case for 60 seconds: J package	300°C
Lead temperature 1/16 inch (1,6 mm) from case for 10 seconds: N package	260°C

- NOTES: 1. All voltage values are with respect to the network ground terminal.  
 2. For operation above 25°C free-air temperature, derate the J package to 880 mW at 70°C at the rate of 11 mW/°C and the N package to 736 mW at 70°C at the rate of 9.2 mW/°C. In the J package, SN75172 chips are alloy-mounted.

### recommended operating conditions

	MIN	NOM	MAX	UNIT
Supply voltage, $V_{CC}$	4.75	5	5.25	V
Common-mode output voltage, $V_{OC}$	-7 <sup>†</sup>		12	V
High-level output current, $I_{OH}$			-60	mA
Low-level output current, $I_{OL}$			60	mA
Operating free-air temperature, $T_A$	0		70	°C

<sup>†</sup>The algebraic convention, where the less-positive (more-negative) limit is designated minimum, is used in this data sheet with common-mode output voltage only.

### electrical characteristics over recommended ranges of supply voltage and operating free-air temperature (unless other noted)

PARAMETER	TEST CONDITIONS	MIN	TYP <sup>‡</sup>	MAX	UNIT
$V_{IH}$ High-level input voltage		2			V
$V_{IL}$ Low-level input voltage				0.8	V
$V_{IK}$ Input clamp voltage	$I_I = -18$ mA			-1.5	V
$V_{OH}$ High-level output voltage	$V_{IH} = 2$ V, $I_{OH} = -33$ mA $V_{IL} = 0.8$ V,		3.7		V
$V_{OL}$ Low-level output voltage	$V_{IH} = 2$ V, $I_{OL} = 33$ mA $V_{IL} = 0.8$ V,		1.1		V
$ V_{OD1} $ Differential output voltage	$I_O = 0$			$2V_{OD2}$	V
$ V_{OD2} $ Differential output voltage	$R_L = 100 \Omega$ , See Figure 1	2			V
	$R_L = 60 \Omega$ , See Figure 1	1.5			V
$\Delta V_{OD} $ Change in magnitude of differential output voltage <sup>§</sup>	$R_L = 60 \Omega$ or $100 \Omega$ , See Figure 1			$\pm 0.2$	V
$V_{OC}$ Common-mode output voltage <sup>¶</sup>				3	V
$\Delta V_{OC} $ Change in magnitude of common-mode output voltage <sup>§</sup>				$\pm 0.2$	V
$I_O$ Output current with power off	$V_{CC} = 0$ , $V_O = -7$ V to 12			$\pm 100$	$\mu$ A
$I_{OZ}$ High-impedance-state output current	$V_O = -7$ V to 12 V			$\pm 100$	$\mu$ A
$I_{IH}$ High-level input current	$V_I = 2.7$ V			20	$\mu$ A
$I_{IL}$ Low-level input current	$V_I = 0.5$ V			-360	$\mu$ A
$I_{OS}$ Short-circuit output current	$V_O = -7$ V			-180	mA
	$V_O = V_{CC}$			180	
	$V_O = 12$ V			500	
$I_{CC}$ Supply current (all drivers)	No load	Outputs enabled	38	60	mA
		Outputs disabled	18	40	

<sup>‡</sup>All typical values are at  $V_{CC} = 5$  V and  $T_A = 25^\circ$  C.

<sup>§</sup> $\Delta|V_{OD}|$  and  $\Delta|V_{OC}|$  are the changes in magnitude of  $V_{OD}$  and  $V_{OC}$ , respectively, that occur when the input is changed from a high level to a low level.

<sup>¶</sup>In EIA Standard RS-422A,  $V_{OC}$ , which is the average of the two output voltages with respect to ground, is called output offset voltage,  $V_{OS}$ .

# TYPE SN75172 QUADRUPLE DIFFERENTIAL LINE DRIVER

switching characteristics,  $V_{CC} = 5\text{ V}$ ,  $T_A = 25^\circ\text{C}$

PARAMETER	TEST CONDITIONS	MIN	TYP	MAX	UNIT
$t_{DD}$	Differential-output delay time		35	50	ns
$t_{TD}$	Differential-output transition time		50	75	ns
$t_{PLH}$	Propagation delay time, low-to-high-level output		16	25	ns
$t_{PHL}$	Propagation delay time, high-to-low-level output		44	65	ns
$t_{PZH}$	Output enable time to high level		60	80	ns
$t_{PZL}$	Output enable time to low level		30	45	ns
$t_{PHZ}$	Output disable time from high level		51	75	ns
$t_{PLZ}$	Output disable time from low level		18	30	ns

## PARAMETER MEASUREMENT INFORMATION

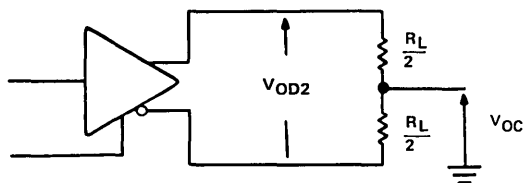
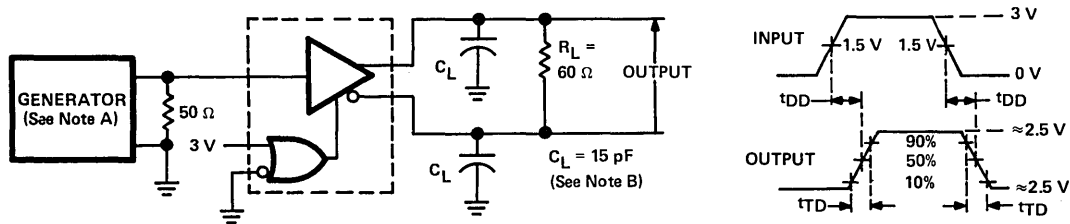

FIGURE 1—DIFFERENTIAL AND COMMON-MODE OUTPUT VOLTAGES



TEST CIRCUIT

VOLTAGE WAVEFORMS

- NOTES: A. The input pulse is supplied by a generator having the following characteristics:  $t_r \leq 5\text{ ns}$ ,  $t_f \leq 5\text{ ns}$ ,  $\text{PRR} = 1\text{ MHz}$ , duty cycle = 50%,  $Z_o = 50\ \Omega$ .  
 B.  $C_L$  includes probe and stray capacitance.  
 C. All diodes are IN916 or IN3064.

FIGURE 2—DIFFERENTIAL-OUTPUT DELAY AND TRANSITION TIMES

**TEXAS INSTRUMENTS**  
INCORPORATED

POST OFFICE BOX 225012 • DALLAS, TEXAS 75265

# TYPE SN75172 QUADRUPLE DIFFERENTIAL LINE DRIVER

## PARAMETER MEASUREMENT INFORMATION

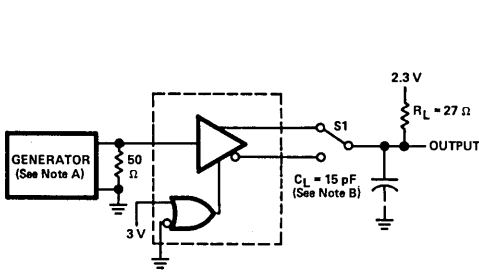

TEST CIRCUIT

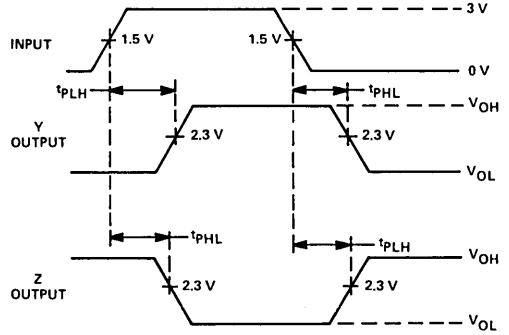

VOLTAGE WAVEFORMS

FIGURE 3—PROPAGATION DELAY TIMES

5

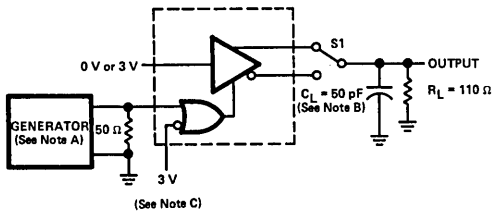

TEST CIRCUIT

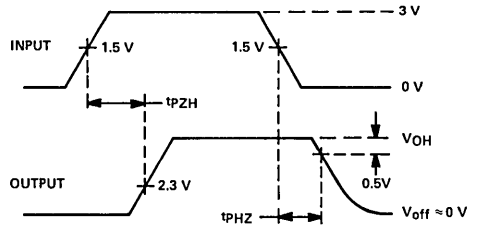

VOLTAGE WAVEFORMS

FIGURE 4— $t_{pZH}$  AND  $t_{pHZ}$

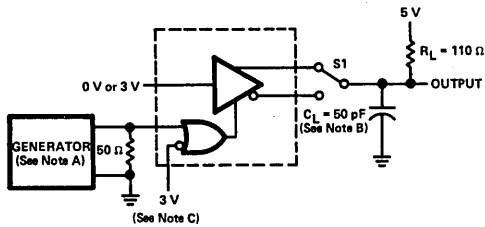

TEST CIRCUIT

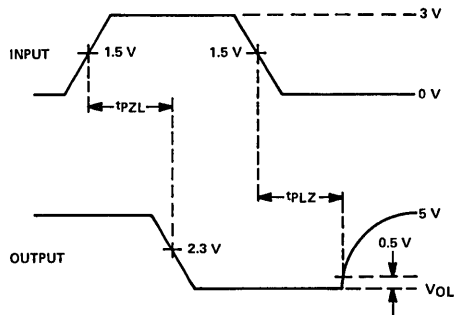

VOLTAGE WAVEFORMS

FIGURE 5— $t_{pZL}$  AND  $t_{pLZ}$

NOTES: A. The input pulse is supplied by a generator having the following characteristics:  $t_f \leq 5$  ns,  $t_r \leq 5$  ns, PRR = 1 MHz, duty cycle = 50%,  $Z_{out} = 50 \Omega$ .

B.  $C_L$  include probe and jig capacitance.

C. To test the active-low enable  $\overline{G}$ , ground G and apply an inverted waveform to  $\overline{G}$ .

# TYPE SN75172 QUADRUPLE DIFFERENTIAL LINE DRIVER

## TYPICAL CHARACTERISTICS

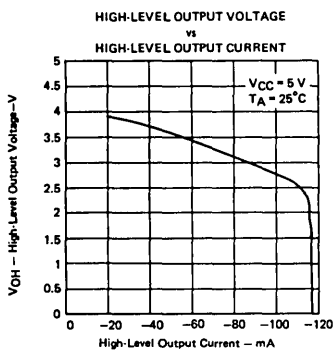

FIGURE 6

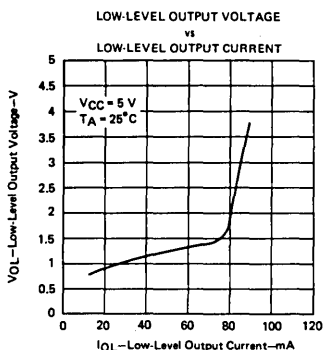

FIGURE 7

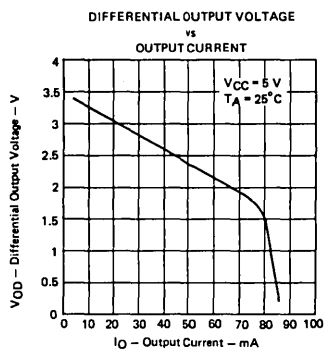

FIGURE 8

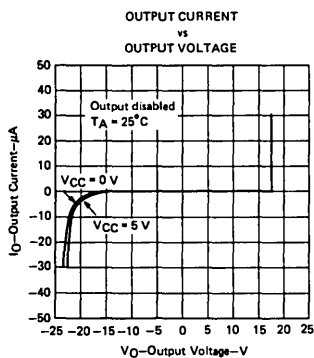

FIGURE 9

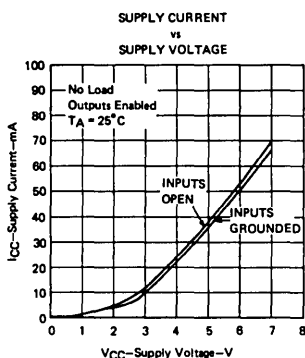

FIGURE 10

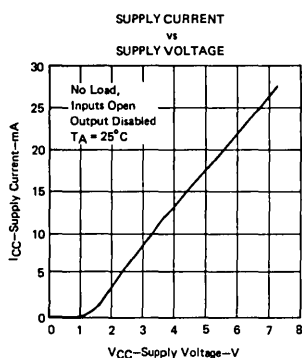
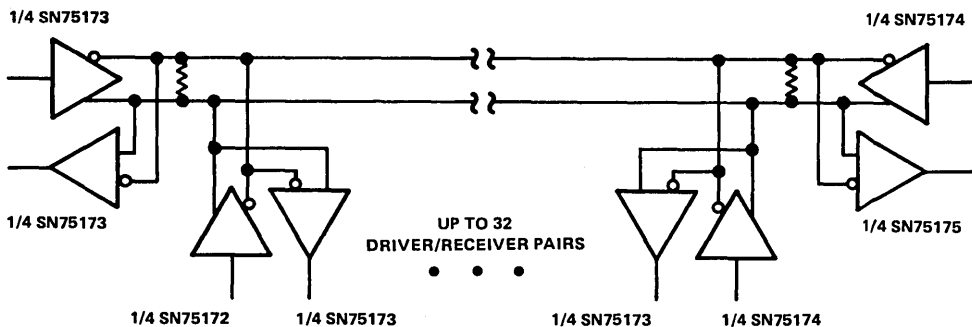

FIGURE 11

## TYPICAL APPLICATION



NOTE: The line length should be terminated at both ends in its characteristic impedance. Stub lengths off the main line should be kept as short as possible.

FIGURE 12

# INTERFACE CIRCUITS

# TYPE SN75173 QUADRUPLE DIFFERENTIAL LINE RECEIVER

BULLETIN NO. DL-S 12770, OCTOBER 1980

- Meets EIA Standards RS-422A and RS-423A
- Meets CCITT Recommendations V.10, V.11 X.26, and X.27
- Meets EIA Subcommittee TR30.1 Draft Standard PN1360 (as of April 1980)
- Designed for Multipoint Bus Transmission on Long Bus Lines in Noisy Environments
- 3-State Outputs
- Common-Mode Input Voltage Range . . . -12 V to 12 V
- Input Sensitivity . . . ±200 mV
- Input Hysteresis . . . 50 mV Typ
- High Input Impedance . . . 12 kΩ Min
- Operates from Single 5-Volt Supply
- Low Power Requirements
- Plug-In Replacement for AM26LS32

5

### description

The SN75173 is a monolithic quadruple differential line receiver with three state outputs. It is designed to meet the requirements of EIA Standards RS-422A and RS-423A and several CCITT recommendations. The device is optimized for balanced multipoint bus transmission at rates up to 10 megabits per second. Each receiver features an active-high enable and an active-low enable common to all four receivers. It also features high input impedance, input hysteresis for increased noise immunity, and input sensitivity of ±200 millivolts over a common-mode input voltage range of -12 volts to 12 volts. The SN75173 is designed for optimum performance when used with the SN75172 or SN75174 quadruple differential line drivers.

The SN75173 is characterized for operation from 0°C to 70°C.

### schematics of inputs and outputs

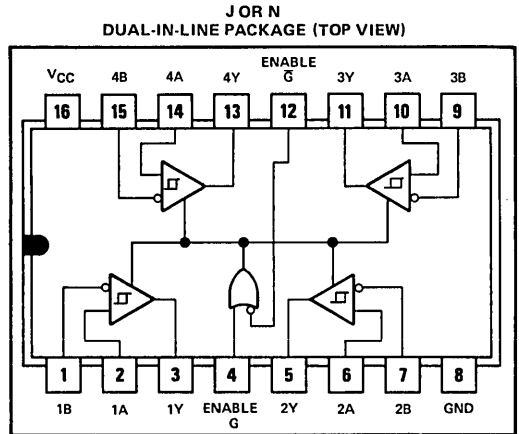
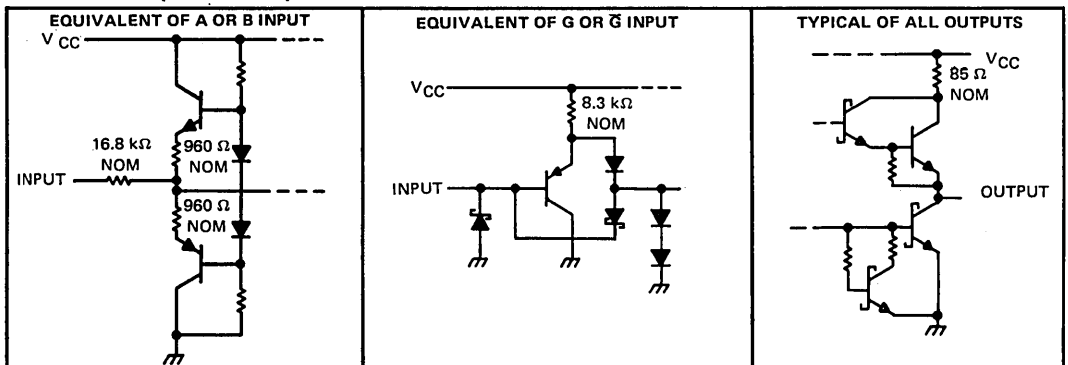

FUNCTION TABLE (EACH RECEIVER)

DIFFERENTIAL INPUTS A - B	ENABLES		OUTPUT Y
	G	G-bar	
$V_{ID} > 0.2 V$	H	X	H
	X	L	H
$-0.2 V < V_{ID} < 0.2 V$	H	X	?
	X	L	?
$V_{ID} < -0.2 V$	H	X	L
	X	L	L
X	L	H	Z

H = high level  
L = low level  
X = Irrelevant  
? = Indeterminate  
Z = high-impedance (off)

Copyright © 1980 by Texas Instruments Incorporated



# TYPE SN75173

## QUADRUPLE DIFFERENTIAL LINE RECEIVER

### absolute maximum ratings over operating free-air temperature range (unless otherwise noted)

Supply voltage, $V_{CC}$ (see Note 1)	7 V
Input voltage, A or B inputs	$\pm 25$ V
Differential input voltage (see Note 2)	$\pm 25$ V
Enable input voltage	7 V
Low-level output current	50 mA
Continuous total dissipation at (or below) 25°C free-air temperature (see Note 3):	
J Package	1025 mW
N Package	1150 mW
Operating free-air temperature range	0°C to 70°C
Storage temperature range	-65°C to 150°C
Lead temperature 1/16 inch (1,6 mm) from case for 60 seconds: J Package	300°C
Lead temperature 1/16 inch (1,6 mm) from case for 10 seconds: N Package	260°C

- NOTES: 1. All voltage values, except differential input voltage, are with respect to network ground terminal.  
 2. Differential-input voltage is measured at the noninverting input with respect to the corresponding inverting input.  
 3. For operation above 25°C free-air temperature, derate the J package to 656 mW at 70°C at the rate of 8.2 mW/°C and the N package to 736 mW at 70°C at the rate of 9.2 mW/°C. In the J package, SN75173 chips are glass-mounted.

### recommended operating conditions

	MIN	NOM	MAX	UNIT
Supply voltage, $V_{CC}$	4.75	5	5.25	V
Common-mode input voltage, $V_{IC}$			$\pm 12$	V
Differential input voltage, $V_{ID}$			$\pm 12$	V
High-level output current, $I_{OH}$			-400	$\mu$ A
Low-level output current, $I_{OL}$			16	mA
Operating free-air temperature, $T_A$	0		70	°C

### electrical characteristics over recommended ranges of common-mode input voltage, supply voltage, and operating free-air temperature (unless otherwise noted)

PARAMETER	TEST CONDITIONS	MIN	TYP†	MAX	UNIT
$V_{TH}$	Differential-input high-threshold voltage $V_O = 2.7$ V, $I_O = -0.4$ mA			0.2	V
$V_{TL}$	Differential-input low-threshold voltage $V_O = 0.5$ V, $I_O = 16$ mA	-0.2‡			V
$V_{T+} - V_{T-}$	Hysteresis§		50		mV
$V_{IH}$	High-level enable input voltage	2			V
$V_{IL}$	Low-level enable input voltage			0.8	V
$V_{JK}$	Enable-input clamp voltage $I_I = -18$ mA			-1.5	V
$V_{OH}$	High-level output voltage $V_{ID} = 200$ mV, $I_{OH} = -400$ $\mu$ A	2.7			V
$V_{OL}$	Low-level output voltage $V_{ID} = -200$ mV, $I_{OL} = 8$ mA $I_{OL} = 16$ mA			0.45 0.5	V
$I_{OZ}$	High-impedance-state output current $V_O = 0.4$ V to 2.4 V			$\pm 20$	$\mu$ A
$I_I$	Line input current Other input at 0 V, See Note 4 $V_I = 12$ V $V_I = -7$ V			1 -0.8	mA
$I_{IH}$	High-level enable-input current $V_{IH} = 2.7$ V			20	$\mu$ A
$I_{IL}$	Low-level enable-input current $V_{IL} = 0.4$ V			-100	$\mu$ A
$r_i$	Input resistance	12			k $\Omega$
$I_{OS}$	Short-circuit output current¶	-15		-85	mA
$I_{CC}$	Supply current Outputs disabled			70	mA

† All typical values are at  $V_{CC} = 5$  V,  $T_A = 25^\circ$  C

‡ The algebraic convention, where the less-positive (more-negative) limit is designated minimum, is used in this data sheet for threshold voltage levels only.

§ Hysteresis is the difference between the positive-going input threshold voltage,  $V_{T+}$ , and the negative-going input threshold voltage,  $V_{T-}$ . See Figure 4.

¶ Not more than one output should be shorted at a time and the duration of the short-circuit should not exceed one second.

NOTE 4: Refer to EIA Standard RS-422A and RS-423A for exact conditions.

# TYPE SN75173

## QUADRUPLE DIFFERENTIAL LINE RECEIVER

switching characteristics,  $V_{CC} = 5\text{ V}$ ,  $T_A = 25^\circ\text{C}$

PARAMETER		TEST CONDITIONS		MIN	TYP	MAX	UNIT
$t_{PLH}$	Propagation delay time, low-to-high-level output	$V_{ID} = -2.5\text{ V to } 2.5\text{ V}$ ,	$C_L = 15\text{ pF}$ ,		20	35	ns
$t_{PHL}$	Propagation delay time, high-to-low-level output	See Figure 1			22	35	ns
$t_{PZH}$	Output enable time to high level	$C_L = 15\text{ pF}$ ,	See Figure 2		17	22	ns
$t_{PZL}$	Output enable time to low level	$C_L = 15\text{ pF}$ ,	See Figure 3		20	25	ns
$t_{PHZ}$	Output disable time from high level	$C_L = 5\text{ pF}$ ,	See Figure 2		21	30	ns
$t_{PLZ}$	Output disable time from low level	$C_L = 5\text{ pF}$ ,	See Figure 3		30	40	ns

### PARAMETER MEASUREMENT INFORMATION

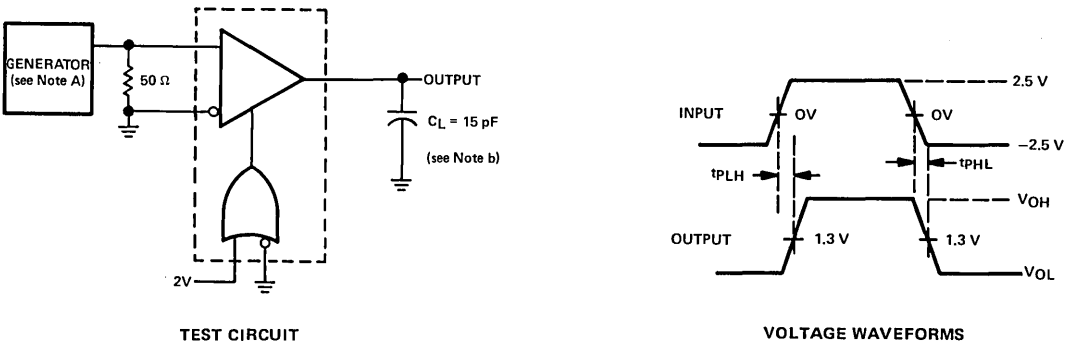

FIGURE 1 —  $t_{PLH}$ ,  $t_{PHL}$

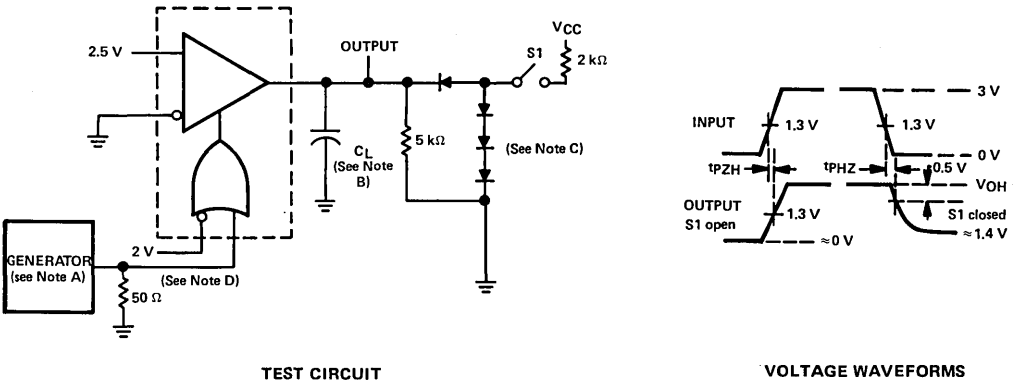
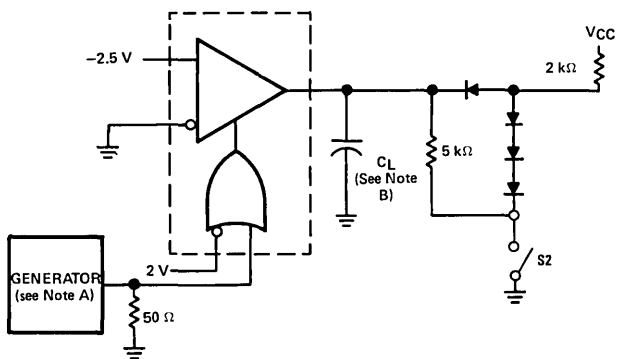

FIGURE 2 —  $t_{PHZ}$ ,  $t_{PZH}$

- NOTES: A. The input pulse is supplied by a generator having the following characteristics: PRR = 1 MHz, duty cycle = 50%,  $t_r = t_f = 6\text{ ns}$ ,  $Z_{out} = 50\ \Omega$ .
- B.  $C_L$  includes probe and jig capacitance.
- C. All diodes are in 916 or equivalent.
- D. To test the active low enable  $\bar{G}$ , ground G and apply an inverted input waveform to  $\bar{G}$ .

# TYPE SN75173 QUADRUPLE DIFFERENTIAL LINE RECEIVER

## PARAMETER MEASUREMENT INFORMATION



TEST CIRCUIT

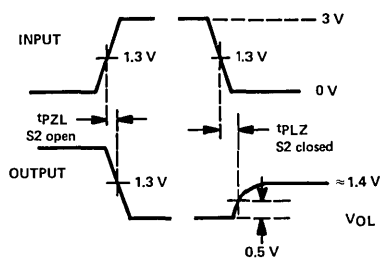

VOLTAGE WAVEFORMS

- NOTES: A. The input pulse is supplied by a generator having the following characteristics: PRR = 1 MHz, duty cycle = 50%,  $t_r = t_f = 6$  ns,  $Z_{out} = 50 \Omega$ .  
 B.  $C_L$  includes probe and jig capacitance.  
 C. All diodes are in 916 or equivalent.  
 D. To test the active low enable  $\bar{G}$ , ground  $\bar{G}$  and apply an inverted input waveform to  $\bar{G}$ .

FIGURE 3 —  $t_{PZL}$ ,  $t_{PLZ}$

## TYPICAL CHARACTERISTICS

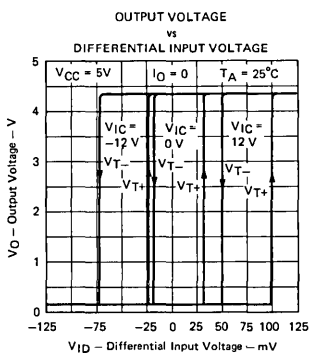

FIGURE 4

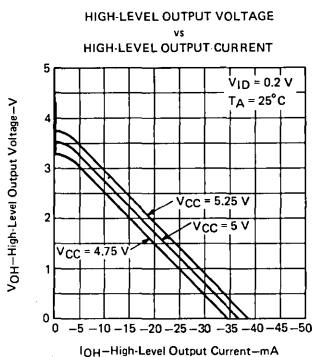

FIGURE 5

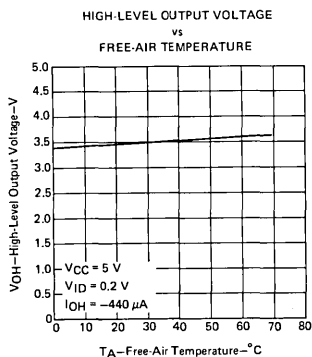

FIGURE 6

# TYPE SN75173

## QUADRUPLE DIFFERENTIAL LINE RECEIVER

### TYPICAL CHARACTERISTICS

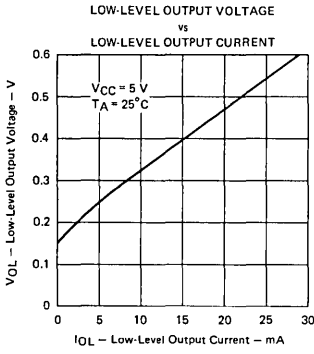

FIGURE 7

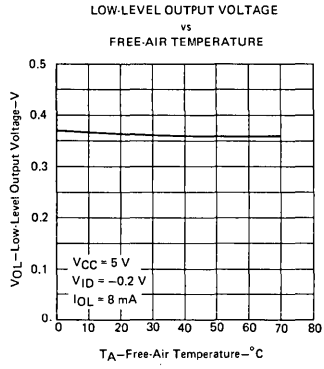

FIGURE 8

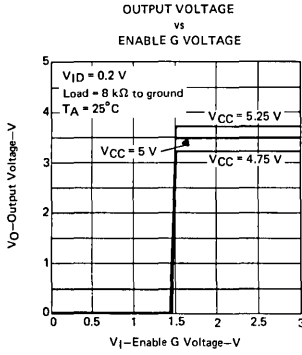

FIGURE 9

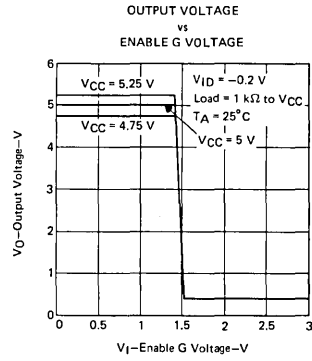
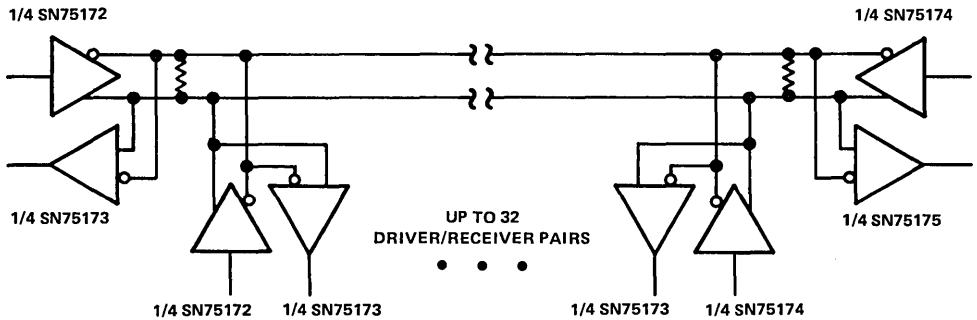

FIGURE 10

### TYPICAL APPLICATION



NOTE: The line should be terminated at both ends in its characteristic impedance. Stub lengths off the main line should be kept as short as possible.

FIGURE 11

- Meets EIA Standard RS-422A and CCITT Recommendations V.11 and X.27
- Meets EIA Subcommittee TR30.1 Draft Standard PN1360 (as of April 1980)
- Designed for Multipoint Transmission on Long Bus Lines in Noisy Environments
- 3-State Outputs
- Common-Mode Output Voltage Range ... -7 V to 12 V
- Active-High Enables
- Thermal Shutdown Protection
- Positive and Negative Current Limiting
- Operates from Single 5-Volt Supply
- Low Power Requirements
- Functionally Interchangeable with MC3487

### description

The SN75174 is a monolithic quadruple differential line driver with three-state outputs. It is designed to meet the requirements of EIA Standard RS-422A and CCITT Recommendations V.11 and X.27. The device is optimized for balanced multipoint bus transmission

at rates up to 4 megabits per second. Each driver features wide positive and negative common-mode output voltage ranges making it suitable for party-line applications in noisy environments.

The SN75174 provides positive- and negative-current limiting and thermal shutdown for protection from line fault conditions on the transmission bus line. Shutdown occurs at a junction temperature of approximately 150°C. This device offers optimum performance when used with the SN75173 or SN75175 quadruple differential line receivers.

The SN75174 is characterized for operation from 0°C to 70°C.

### schematics of inputs and outputs

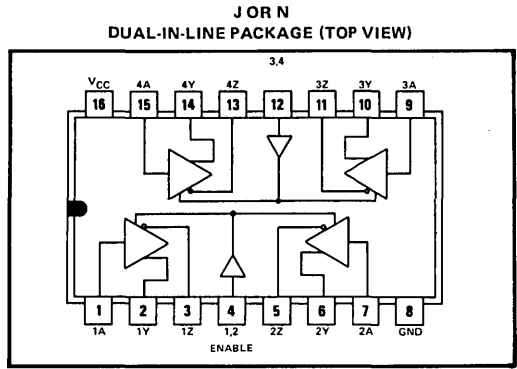
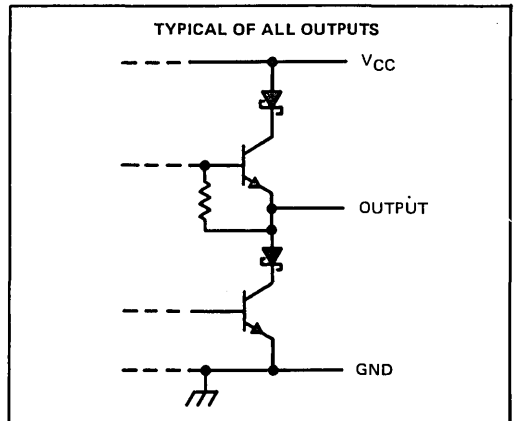
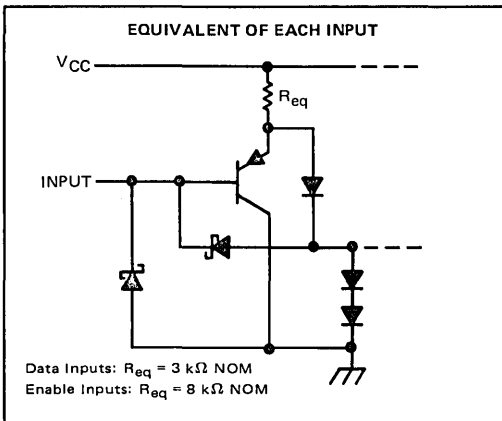

FUNCTION TABLE (EACH DRIVER)

INPUT	ENABLE	OUTPUTS	
		Y	Z
H	H	H	L
L	H	L	H
X	L	Z	Z

H = TTL high level, L = TTL low level, X = irrelevant, Z = high impedance (off)

5

# TYPE SN75174

## QUADRUPLE DIFFERENTIAL LINE DRIVER

### absolute maximum ratings over operating free-air temperature range (unless otherwise noted)

Supply voltage, $V_{CC}$ (see Note 1)	7 V
Input voltage	5.5 V
Continuous total dissipation at (or below) 25°C free-air temperature (see Note 2):	
J package	1375 mW
N package	1150 mW
Operating free-air temperature range	0°C to 70°C
Storage temperature range	-65°C to 150°C
Lead temperature 1/16 inch (1,6 mm) from case for 60 seconds: J package	300°C
Lead temperature 1/16 inch (1,6 mm) from case for 10 seconds: N package	260°C

NOTES: 1. All voltage values are with respect to the network ground terminal.

2. For operation above 25°C free-air temperature, derate the J package to 880 mW at 70°C at the rate of 11 mW/°C and the N package to 736 mW at 70°C at the rate of 9.2 mW/°C. In the J package, SN75174 chips are alloy-mounted.

### recommended operating conditions

	MIN	NOM	MAX	UNIT
Supply voltage, $V_{CC}$	4.75	5	5.25	V
Common-mode output voltage, $V_{OC}$	-7 <sup>†</sup>		12	V
High-level output current, $I_{OH}$			-60	mA
Low-level output current, $I_{OL}$			60	mA
Operating free-air temperature, $T_A$	0		70	°C

<sup>†</sup>The algebraic convention, where the less-positive (more-negative) limit is designated minimum, is used in this data sheet with common-mode output voltage only.

### electrical characteristics over recommended ranges of supply voltage and operating free-air temperature (unless other noted)

PARAMETER	TEST CONDITIONS	MIN	TYP <sup>‡</sup>	MAX	UNIT
$V_{IH}$	High-level input voltage	2			V
$V_{IL}$	Low-level input voltage			0.8	V
$V_{IK}$	Input clamp voltage			-1.5	V
$V_{OH}$	High-level output voltage	$I_I = -18$ mA	3.7		V
$V_{OL}$	Low-level output voltage	$V_{IH} = 2$ V, $I_{OH} = -33$ mA	1.1		V
$ V_{OD1} $	Differential output voltage	$V_{IH} = 2$ V, $I_{OL} = 33$ mA		$2V_{OD2}$	V
$ V_{OD2} $	Differential output voltage	$I_O = 0$			V
$\Delta V_{OD} $	Change in magnitude of differential output voltage <sup>§</sup>	$R_L = 100 \Omega$ , See Figure 1		±0.2	V
$V_{OC}$	Common-mode output voltage <sup>¶</sup>	$R_L = 60 \Omega$ or $100 \Omega$ , See Figure 1		3	V
$\Delta V_{OC} $	Change in magnitude of common-mode output voltage <sup>§</sup>			±0.2	V
$I_O$	Output current with power off	$V_{CC} = 0$ , $V_O = -7$ V to 12 V		±100	μA
$I_{OZ}$	High-impedance-state output current	$V_O = -7$ V to 12 V		±100	μA
$I_{IH}$	High-level input current	$V_I = 2.7$ V		20	μA
$I_{IL}$	Low-level input current	$V_I = 0.5$ V		-360	μA
$I_{OS}$	Short-circuit output current	$V_O = -7$ V		-180	mA
		$V_O = V_{CC}$		180	mA
		$V_O = 12$ V		500	mA
$I_{CC}$	Supply current (all drivers)	No load			mA
		Outputs enabled	38	60	
		Outputs disabled	18	40	

<sup>‡</sup>All typical values are at  $V_{CC} = 5$  V and  $T_A = 25^\circ$  C.

<sup>§</sup> $\Delta|V_{OD}|$  and  $\Delta|V_{OC}|$  are the changes in magnitude of  $V_{OD}$  and  $V_{OC}$ , respectively, that occur when the input is changed from a high level to a low level.

<sup>¶</sup>In EIA Standard RS-422A,  $V_{OC}$ , which is the average of the two output voltages with respect to ground, is called output offset voltage,  $V_{OS}$ .

# TYPE SN75174 QUADRUPLE DIFFERENTIAL LINE DRIVER

switching characteristics,  $V_{CC} = 5\text{ V}$ ,  $T_A = 25^\circ\text{C}$

PARAMETER	TEST CONDITIONS	MIN	TYP	MAX	UNIT
$t_{DD}$ Differential-output delay time	$R_L = 60\ \Omega$ , See Figure 2		35	50	ns
$t_{TD}$ Differential-output transition time			50	75	ns
$t_{PLH}$ Propagation delay time, low-to-high-level output	$R_L = 27\ \Omega$ , See Figure 3		16	25	ns
$t_{PHL}$ Propagation delay time, high-to-low-level output			44	65	ns
$t_{PZH}$ Output enable time to high level	$R_L = 110\ \Omega$ , See Figure 4		60	80	ns
$t_{PZL}$ Output enable time to low level	$R_L = 110\ \Omega$ , See Figure 5		30	45	ns
$t_{PHZ}$ Output disable time from high level	$R_L = 110\ \Omega$ , See Figure 4		51	75	ns
$t_{PLZ}$ Output disable time from low level	$R_L = 110\ \Omega$ , See Figure 5		18	30	ns

## PARAMETER MEASUREMENT INFORMATION

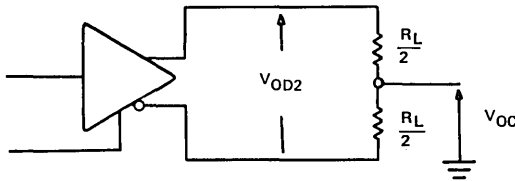
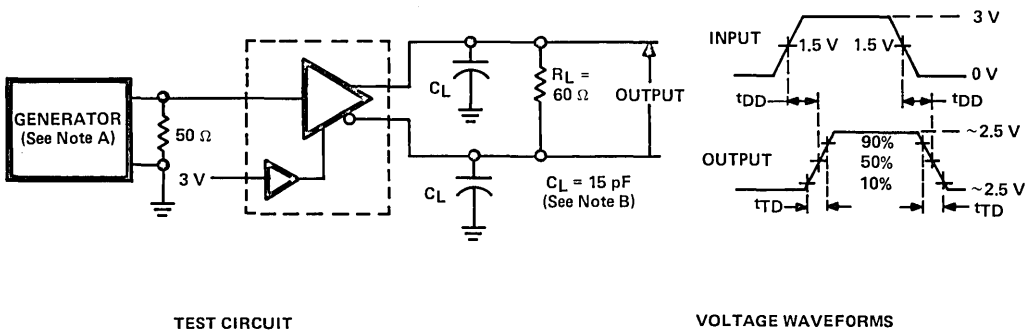

FIGURE 1—DIFFERENTIAL AND COMMON-MODE OUTPUT VOLTAGES



- NOTES: A. The Input pulse is supplied by a generator having the following characteristics:  $t_r \leq 5\text{ ns}$ ,  $t_f \leq 5\text{ ns}$ ,  $\text{PRR} = 1\text{ MHz}$ , duty cycle = 50%,  $Z_o = 50\ \Omega$ .  
 B.  $C_L$  includes probe and stray capacitance.  
 C. All diodes are IN916 or IN3064.

FIGURE 2—DIFFERENTIAL-OUTPUT DELAY AND TRANSITION TIMES

**TEXAS INSTRUMENTS**  
INCORPORATED

POST OFFICE BOX 225012 • DALLAS, TEXAS 75265

# TYPE SN75174 QUADRUPLE DIFFERENTIAL LINE DRIVER

## PARAMETER MEASUREMENT INFORMATION

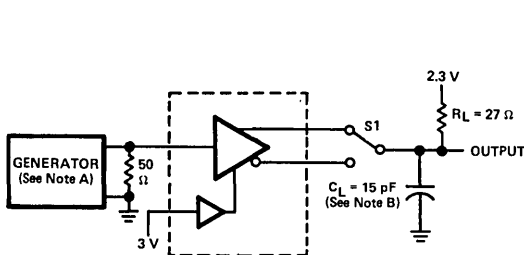

TEST CIRCUIT

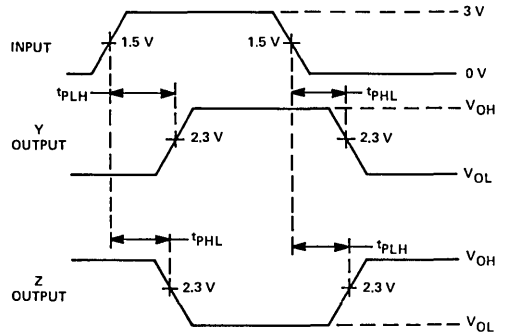

VOLTAGE WAVEFORMS

FIGURE 3—PROPAGATION DELAY TIMES

5

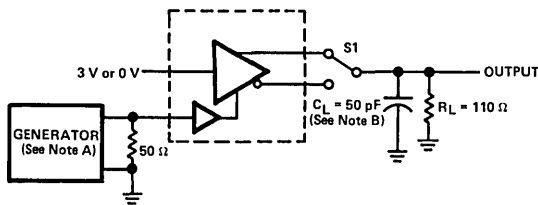

TEST CIRCUIT

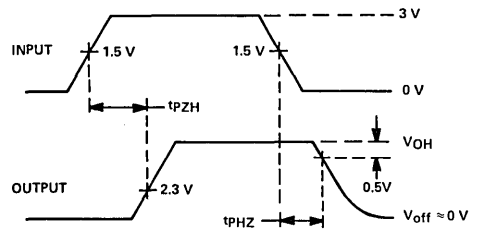

VOLTAGE WAVEFORMS

FIGURE 4— $t_{pZH}$  AND  $t_{pHZ}$

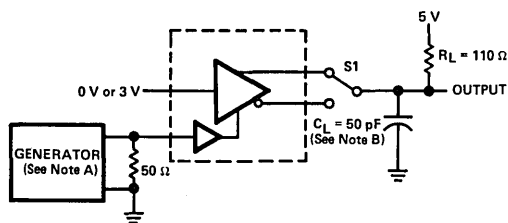

TEST CIRCUIT

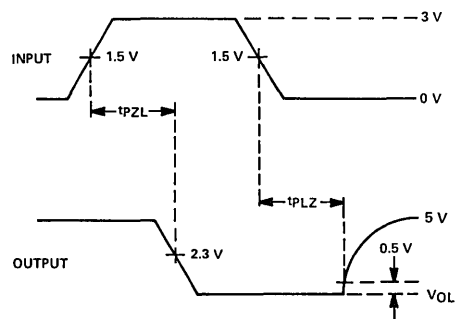

VOLTAGE WAVEFORMS

FIGURE 5— $t_{pZL}$  AND  $t_{pLZ}$

NOTES: A. The input pulse is supplied by a generator having the following characteristics: PRR = 1 MHz, duty cycle = 50%,  $t_r \leq 5$  ns,  $t_f \leq 5$  ns,  $Z_o = 50 \Omega$ .

B.  $C_L$  includes probe and stray capacitance.



# TYPE SN75174 QUADRUPLE DIFFERENTIAL LINE DRIVER

## TYPICAL CHARACTERISTICS

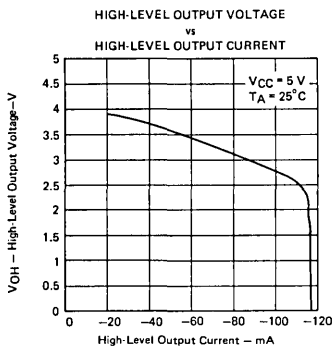

FIGURE 6

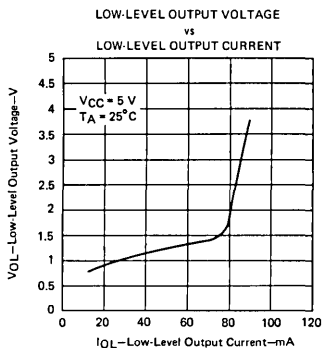

FIGURE 7

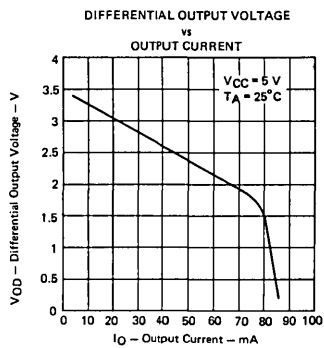

FIGURE 8

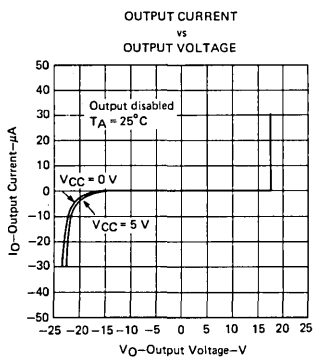

FIGURE 9

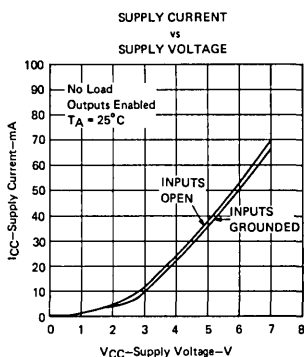

FIGURE 10

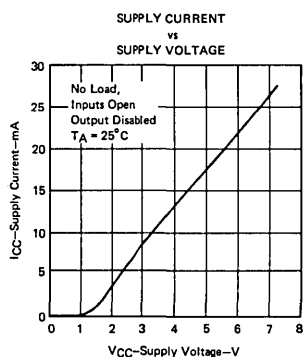
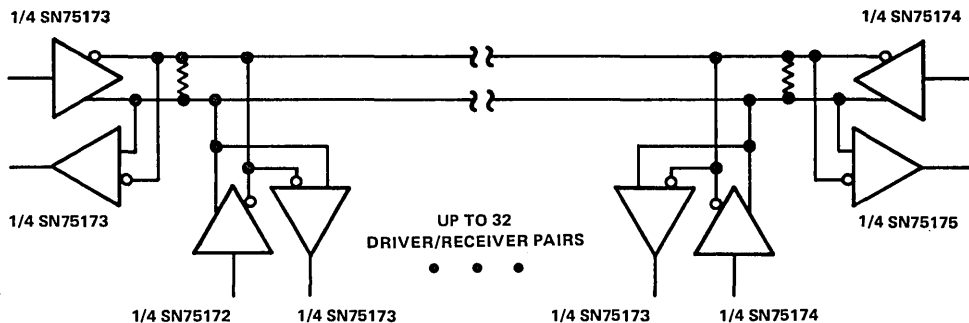

FIGURE 11

5

## TYPICAL APPLICATION



NOTE: The line length should be terminated at both ends in its characteristic impedance. Stub lengths off the main line should be kept as short as possible.

FIGURE 12

# INTERFACE CIRCUITS

# TYPE SN75175 QUADRUPLE DIFFERENTIAL LINE RECEIVER

BULLETIN NO. DL-S 12772, OCTOBER 1980

- Meets EIA Standards RS-422A and RS-423A
- Meets CCITT Recommendations V.10, V.11, X.26, and X.27
- Meets EIA Subcommittee TR30.1 Draft Standard PN1360 (as of April 1980)
- Designed for Multipoint Bus Transmission on Long Bus Lines in Noisy Environments
- 3-State Outputs
- Common-Mode Input Voltage Range . . . -12 V to 12 V
- Input Sensitivity . . .  $\pm 200$  mV
- Input Hysteresis . . . 50 mV Typ
- High Input Impedance . . . 12 k $\Omega$  Min
- Operates from Single 5-Volt Supply
- Low Power Requirements
- Plug-In Replacement for MC3486

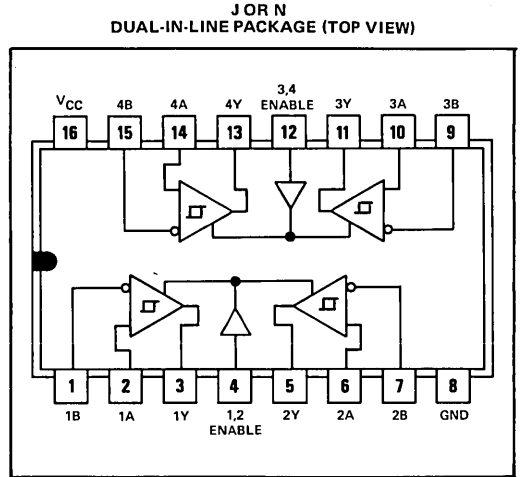

FUNCTION TABLE (EACH RECEIVER)

DIFFERENTIAL INPUTS A - B	ENABLE	OUTPUT Y
$V_{ID} \geq 0.2$ V	H	H
$-0.2$ V $< V_{ID} < 0.2$ V	H	?
$V_{ID} < -0.2$ V	H	L
X	L	Z

H = high level, L = low level, ? = indeterminate,  
X = irrelevant, Z = high impedance (off)

## description

The SN75175 is a monolithic quadrupled differential line receiver with three-state outputs. It is designed to meet the requirements of EIA Standards RS-422A and RS-423A and several CCITT recommendations. The device is optimized for balanced multipoint bus transmission at rates up to 10 megabits per second. Each receiver features two active-high enables, each common to two receivers. It also features high input impedance, input hysteresis for increased noise immunity, and input sensitivity of  $\pm 200$  millivolts over a common-mode input voltage range of -12 volts to 12 volts. The SN75175 is designed for optimum performance when used with the SN75172 or SN75174 quadruple differential line drivers.

## schematics of inputs and outputs

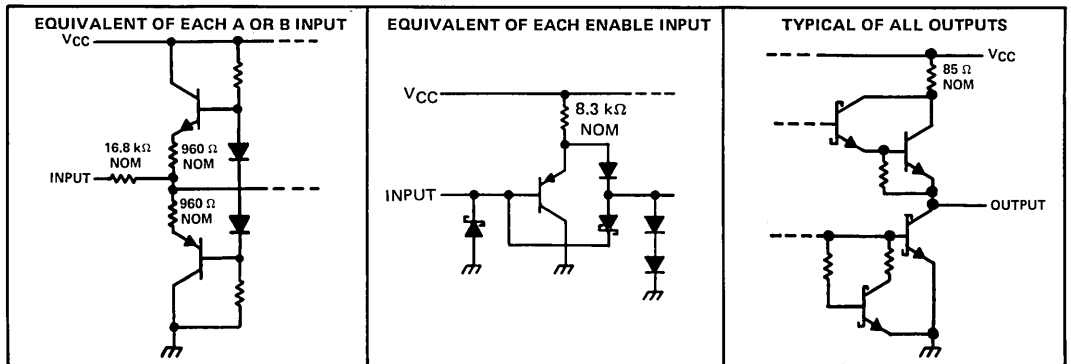

Copyright © 1980 by Texas Instruments Incorporated

# TYPE SN75175

## QUADRUPLE DIFFERENTIAL LINE RECEIVER

### absolute maximum ratings over operating free-air temperature range (unless otherwise noted)

Supply voltage, $V_{CC}$ (see Note 1)	7 V
Input voltage, A or B inputs	$\pm 25$ V
Differential input voltage (see Note 2)	$\pm 25$ V
Enable input voltage	7 V
Low-level output current	50 mA
Continuous total dissipation at (or below) 25°C free-air temperature (see Note 3): J Package	1025 mW
N Package	1150 mW
Operating free-air temperature range	0°C to 70°C
Storage temperature range	-65°C to 150°C
Lead temperature 1/16 inch (1,6 mm) from case for 60 seconds: J Package	300°C
Lead temperature 1/16 inch (1,6 mm) from case for 10 seconds: N Package	260°C

- NOTES: 1. All voltage values, except differential input voltage, are with respect to network ground terminal.  
 2. Differential-input voltage is measured at the noninverting input with respect to the corresponding inverting input.  
 3. For operation above 25°C free-air temperature, derate the J package to 656 mW at 70°C at a rate of 8.2 mW/°C and the N package to 736 mW at 70°C at a rate of 9.2 mW/°C. In the J package, SN75175 chips are glass-mounted.

### recommended operating conditions

	MIN	NOM	MAX	UNIT
Supply voltage, $V_{CC}$	4.75	5	5.25	V
Common-mode input voltage, $V_{IC}$			$\pm 12$	V
Differential input voltage, $V_{ID}$			$\pm 12$	V
High-level output current, $I_{OH}$			-400	$\mu$ A
Low-level output current, $I_{OL}$			16	mA
Operating free-air temperature, $T_A$	0		70	°C

5

### electrical characteristics over recommended ranges of common-mode input voltage, supply voltage, and operating free-air temperature (unless otherwise noted)

PARAMETER	TEST CONDITIONS	MIN	TYP†	MAX	UNIT
$V_{TH}$	Differential-input high-threshold voltage $V_O = 2.7$ V, $I_O = -0.4$ mA			0.2	V
$V_{TL}$	Differential-input low-threshold voltage $V_O = 0.5$ V, $I_O = 16$ mA	-0.2‡			V
$V_{T+} - V_{T-}$	Hysteresis§		50		mV
$V_{IH}$	High-level enable input voltage		2		V
$V_{IL}$	Low-level enable input voltage			0.8	V
$V_{IK}$	Enable-input clamp voltage			-1.5	V
$V_{OH}$	High-level output voltage $V_{ID} = 200$ mV, $I_{OH} = -400$ $\mu$ A, See Figure 1	2.7			V
$V_{OL}$	Low-level output voltage $V_{ID} = -200$ mV, See Figure 1			0.45	V
				0.5	
$I_{OZ}$	High-impedance-state output current $V_O = 0.4$ V to 2.4 V			$\pm 20$	$\mu$ A
$I_I$	Line input current Other input at 0 V, See Note 4			1	mA
				-0.8	
$I_{IH}$	High-level enable-input current $V_{IH} = 2.7$ V			20	$\mu$ A
$I_{IL}$	Low-level enable-input current $V_{IL} = 0.4$ V			-100	$\mu$ A
$r_i$	Input resistance		12		k $\Omega$
$I_{OS}$	Short-circuit output current¶	-15		-85	mA
$I_{CC}$	Supply current Outputs disabled			70	mA

† All typical values are at  $V_{CC} = 5$  V,  $T_A = 25^\circ$  C

‡ The algebraic convention, where the less-positive (more-negative) limit is designated as minimum, is used in this data sheet for threshold voltage levels only.

§ Hysteresis is the difference between the positive-going input threshold voltage,  $V_{T+}$  and the negative-going input threshold voltage,  $V_{T-}$ . See Figure 4.

¶ Not more than one output should be shorted at a time and the duration of the short-circuit should not exceed one second.

NOTE 4: Refer to EIA standards RS-422A and RS-423A for exact conditions.

# TYPE SN75175

## QUADRUPLE DIFFERENTIAL LINE RECEIVER

switching characteristics,  $V_{CC} = 5\text{ V}$ ,  $T_A = 25^\circ\text{C}$

PARAMETER	TEST CONDITIONS	MIN	TYP	MAX	UNIT
$t_{PLH}$ Propagation delay time, low-to-high-level output	$C_L = 15\text{ pF}$ , See Figure 2		22	35	ns
$t_{PHL}$ Propagation delay time, high-to-low-level output			25	35	ns
$t_{PZH}$ Output enable time to high level	$C_L = 15\text{ pF}$ , See Figure 3		13	30	ns
$t_{PZL}$ Output enable time to low level			19	30	ns
$t_{PHZ}$ Output disable time from high level	$C_L = 5\text{ pF}$ , See Figure 3		26	35	ns
$t_{PLZ}$ Output disable time from low level			25	35	ns

### PARAMETER MEASUREMENT INFORMATION

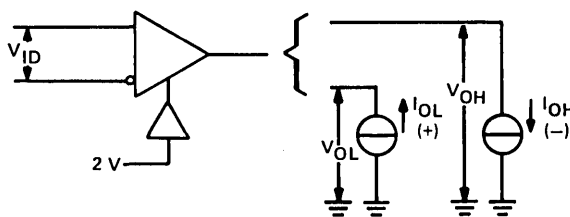

FIGURE 1— $V_{OH}$ ,  $V_{OL}$

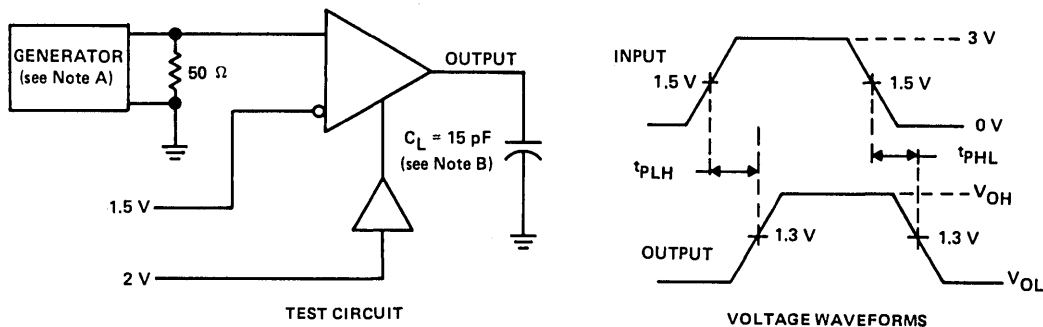
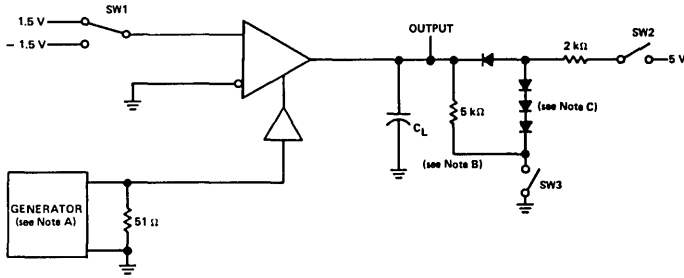

FIGURE 2—PROPAGATION DELAY TIMES

- NOTES: A. The input pulse is supplied by a generator having the following characteristics: PRR + 1 MHz, duty cycle = 50%,  $t_r = t_f = 6\text{ ns}$ ,  $Z_{out} = 50\ \Omega$ .
- B.  $C_L$  includes probe and stray capacitance.

# TYPE SN75175 QUADRUPLE DIFFERENTIAL LINE RECEIVER

## PARAMETER MEASUREMENT INFORMATION



## TEST CIRCUIT

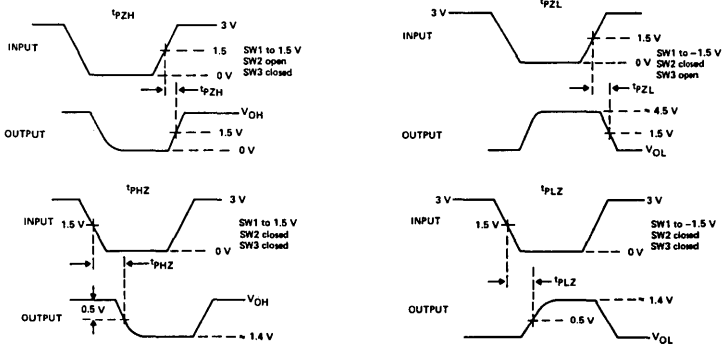

## VOLTAGE WAVEFORMS

FIGURE 3—ENABLE AND DISABLE TIMES

- NOTES: A. The input pulse is supplied by a generator having the following characteristics: PRR = 1 MHz, duty cycle = 50%,  $t_r = t_f = 6$  ns,  $Z_{out} = 50 \Omega$ .  
 B.  $C_L$  includes probe and stray capacitance  
 C. All diodes are 1N916 or equivalent.

## TYPICAL CHARACTERISTICS

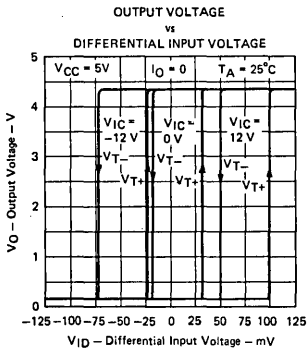

FIGURE 4

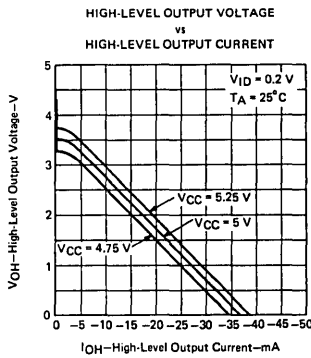

FIGURE 5

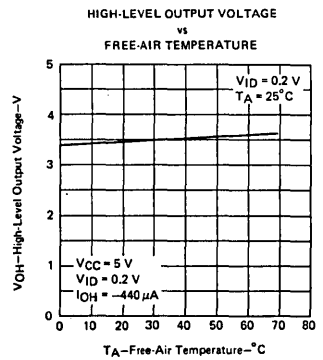

FIGURE 6

**TEXAS INSTRUMENTS**  
INCORPORATED

POST OFFICE BOX 225012 • DALLAS, TEXAS 75265

# TYPE SN75175 QUADRUPLE DIFFERENTIAL LINE RECEIVER

## TYPICAL CHARACTERISTICS

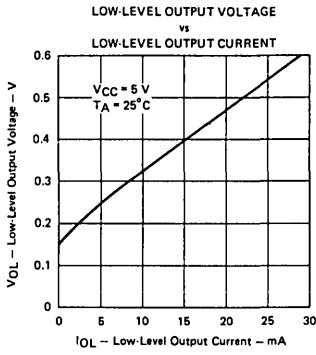

FIGURE 7

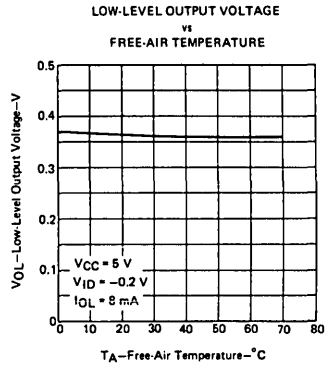

FIGURE 8

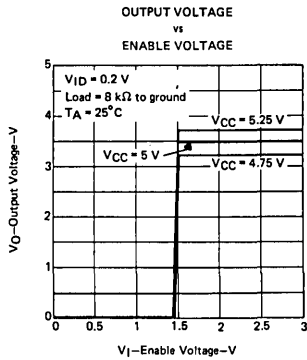

FIGURE 9

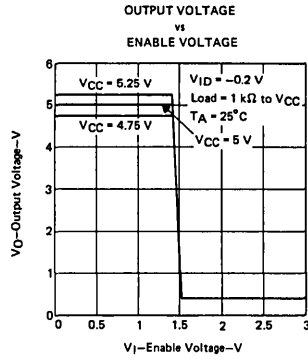

FIGURE 10

## TYPICAL APPLICATION

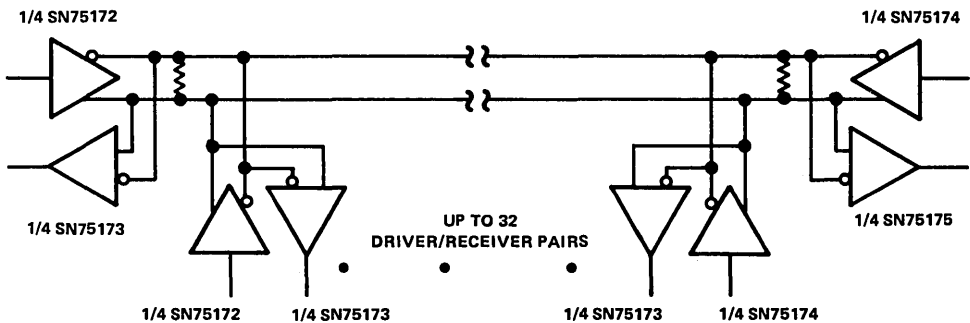

FIGURE 11

NOTE: The line should be terminated at both ends in its characteristic impedance. Stub lengths off the main line should be kept as short as possible.

TEXAS INSTRUMENTS  
INCORPORATED

POST OFFICE BOX 225012 • DALLAS, TEXAS 75265

- Bidirectional Transceiver
- Meets EIA Standard RS-422A and CCITT Recommendations V.11 and X.27
- Meets EIA Subcommittee TR30.1 Draft Standard PN1360 (as of April 1980)
- Designed for Multipoint Transmission on Long Bus Lines in Noisy Environments
- 3-State Driver and Receiver Outputs
- Individual Driver and Receiver Enables
- Wide Positive and Negative Input/Output Bus Voltage Ranges
- Driver Output Capability . . .  $\pm 60$  mA Max
- Thermal Shutdown Protection
- Driver Positive and Negative Current Limiting
- Receiver Input Impedance . . . 12 k $\Omega$  Min
- Receiver Input Sensitivity . . .  $\pm 200$  mV
- Receiver Input Hysteresis . . . 50 mV Typ
- Operates from Single 5-Volt Supply
- Low Power Requirements

**description**

The SN75176 differential bus transceiver is a monolithic integrated circuit designed for bidirectional data communication on multipoint bus transmission lines. It is designed for balanced transmission lines and meets EIA Standard RS-422A, the EIA Subcommittee TR30.1 Draft Standard PN1360, and CCITT Recommendations V.11 and X.27.

The SN75176 combines a three-state differential line driver and a differential-input line receiver both of which operate from a single 5-volt power supply. The driver and receiver have an active enable that can be externally connected to function as a direction control. The driver differential-outputs and the receiver differential-inputs are internally connected to form differential input/output (I/O) bus ports that are designed to offer minimum loading to the bus whenever the driver is disabled or  $V_{CC} = 0$  volts. These ports feature wide positive and negative common-mode voltage ranges making the device suitable for party-line applications.

The driver is designed to handle loads up to 60 milliamperes of sink or source current. The driver features positive- and negative-current limiting and thermal shutdown for protection from line fault conditions. Thermal shutdown is designed to occur at a junction temperature of approximately 150°C. The receiver features a minimum input impedance of 12 k $\Omega$ , an input sensitivity of  $\pm 200$  millivolts, and a typical input hysteresis of 50 millivolts.

The SN75176 can be used in transmission line applications employing the SN75172 and SN75174 quadruple differential line drivers and the SN75173 and SN75175 quadruple differential line receivers.

JG OR P  
DUAL-IN-LINE PACKAGE  
(TOP VIEW)

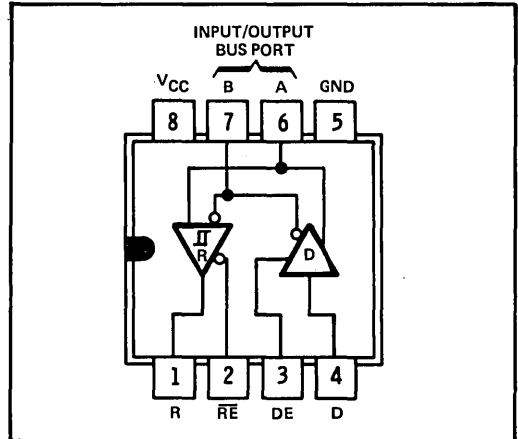

FUNCTION TABLE (DRIVER)

INPUT D	ENABLE DE	OUTPUTS	
		A	B
H	H	H	L
L	H	L	H
X	L	Z	Z

FUNCTION TABLE (RECEIVER)

DIFFERENTIAL INPUTS A - B	ENABLE $\overline{RE}$	OUTPUT R	
		$V_{ID} > 0.2$ V	L
$-0.2$ V $< V_{ID} < 0.2$ V	L	L	?
$V_{ID} < -0.2$ V	L	L	L
X	H	L	Z

H = high level, L = low level, ? = indeterminate,  
X = irrelevant, Z = high impedance (off)

# TYPE SN75176 DIFFERENTIAL BUS TRANSCEIVER

## schematics of inputs and outputs

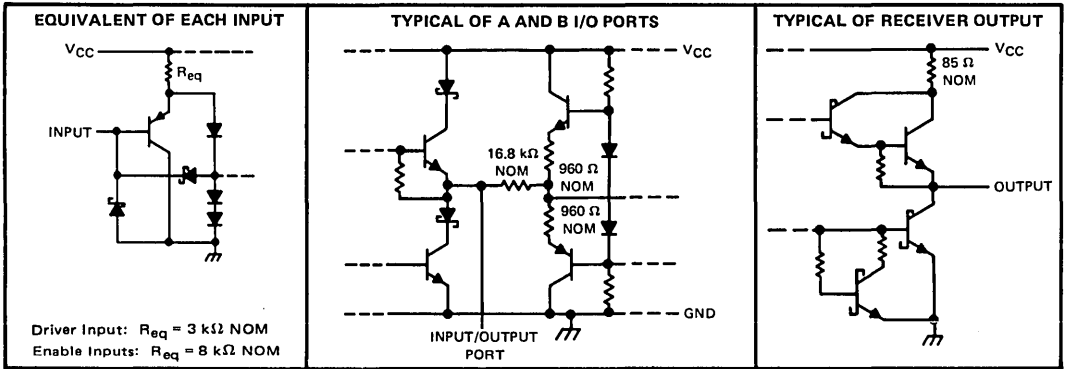

### absolute maximum ratings over operating free-air temperature range (unless otherwise noted)

Supply voltage, $V_{CC}$ (see Note 1)	7 V
Voltage at any bus terminal	-10 V to 15 V
Enable input voltage	5.5 V
Continuous total dissipation at (or below) 25°C free-air temperature (see Note 2): JG Package	825 mW
P Package	1000 mW
Operating free-air temperature range	0°C to 70°C
Storage temperature range	-65°C to 150°C
Lead temperature 1/16 inch (1,6 mm) from case for 60 seconds: JG Package	300°C
Lead temperature 1/16 inch (1,6 mm) from case for 10 seconds: P Package	260°C

- NOTES: 1. All voltage values, except differential input/output bus voltage, are with respect to network ground terminal.  
 2. For operation above 25°C free-air temperature, derate the JG package to 528 mW at 70°C at the rate of 6.6 mW/°C and the P package to 640 mW at 70°C at the rate of 8.0 mW/°C. In the JG package, SN75176 chips are glass-mounted.

### recommended operating conditions

	MIN	NOM	MAX	UNIT
Supply voltage, $V_{CC}$	4.75	5	5.25	V
Voltage at any bus terminal (separately or common-mode), $V_I$ or $V_{IC}$	-7†		12	V
Differential input voltage, $V_{ID}$ (see Note 3)			±12	V
High-level output current, $I_{OH}$	Driver		-60	mA
	Receiver		-400	μA
Low-level output current, $I_{OL}$	Driver		60	mA
	Receiver		16	mA
Operating free-air temperature, $T_A$	0		70	°C

†The algebraic convention, where the less-positive (more-negative) limit is designated minimum, is used in this data sheet for common-mode input voltage and threshold voltage levels only.

NOTE 3: Differential-input/output bus voltage is measured at the noninverting terminal A with respect to the inverting terminal B.



# TYPE SN75176 DIFFERENTIAL BUS TRANSCEIVER

## DRIVER SECTION

driver electrical characteristics over recommended ranges of supply voltage and operating free-air temperature (unless otherwise noted)

PARAMETER	TEST CONDITIONS		MIN	TYP <sup>†</sup>	MAX	UNIT
V <sub>IH</sub>	High-level input voltage		2			V
V <sub>IL</sub>	Low-level input voltage		0.8			V
V <sub>IK</sub>	Input clamp voltage		I <sub>I</sub> = -18 mA -1.5			V
V <sub>OH</sub>	High-level output voltage	V <sub>IH</sub> = 2 V, I <sub>OH</sub> = -33 mA	V <sub>IL</sub> = 0.8 V, 3.7		V	
V <sub>OL</sub>	Low-level output voltage	V <sub>IH</sub> = 2 V, I <sub>OL</sub> = 33 mA	V <sub>IL</sub> = 0.8 V, 1.1		V	
V <sub>OD1</sub>	Differential output voltage	I <sub>O</sub> = 0	2V <sub>OD2</sub>		V	
V <sub>OD2</sub>	Differential output voltage	R <sub>L</sub> = 100 Ω, See Figure 9 R <sub>L</sub> = 54 Ω, See Figure 9	2 1.5	2.7 2.4	V	
ΔV <sub>OD</sub>	Change in magnitude of differential output voltage <sup>‡</sup>	R <sub>L</sub> = 54 Ω or 100 Ω, See Figure 9	±0.2		V	
V <sub>OC</sub>	Common-mode output voltage <sup>§</sup>		3		V	
ΔV <sub>OC</sub>	Change in magnitude of common-mode output voltage <sup>‡</sup>		±0.2		V	
I <sub>O</sub>	Output current	Output disabled, See Note 4	V <sub>O</sub> = 12 V V <sub>O</sub> = -7 V		1 -0.8	mA
I <sub>IH</sub>	High-level input current	V <sub>I</sub> = 2.4 V		20		μA
I <sub>IL</sub>	Low-level input current	V <sub>I</sub> = 0.4 V		-360		μA
I <sub>OS</sub>	Short-circuit output current	V <sub>O</sub> = -7 V V <sub>O</sub> = V <sub>CC</sub> V <sub>O</sub> = 12 V		-180 180 500		mA
I <sub>CC</sub>	Supply current (total package)	No load	Outputs enabled Outputs disabled		35 30	mA

5

<sup>†</sup>All typical values are at V<sub>CC</sub> = 5 V and T<sub>A</sub> = 25°C.

<sup>‡</sup>ΔV<sub>OD</sub> and ΔV<sub>OC</sub> are the changes in magnitude of V<sub>OD</sub> and V<sub>OC</sub>, respectively, that occur when the input is changed from a high level to a low level.

<sup>§</sup>In EIA Standard RS-422A, V<sub>OC</sub>, which is the average of the two output voltages with respect to ground, is called output offset voltage, V<sub>OS</sub>.  
NOTE 4: This applies for both power on and power off. Refer to EIA Standard RS-422A for exact conditions.

driver switching characteristics, V<sub>CC</sub> = 5 V, T<sub>A</sub> = 25°C

PARAMETER	TEST CONDITIONS		MIN	TYP	MAX	UNIT
t <sub>DD</sub>	Differential-output delay time	R <sub>L</sub> = 60 Ω, See Figure 11	35		50	ns
t <sub>TD</sub>	Differential-output transition time		50		75	ns
t <sub>PLH</sub>	Propagation delay time, low-to-high-level output	R <sub>L</sub> = 27 Ω, See Figure 12	16		25	ns
t <sub>PHL</sub>	Propagation delay time, high-to-low-level output		44		65	ns
t <sub>PZH</sub>	Output enable time to high level	R <sub>L</sub> = 110 Ω, See Figure 13	60		80	ns
t <sub>PZL</sub>	Output enable time to low level	R <sub>L</sub> = 110 Ω, See Figure 14	30		45	ns
t <sub>PHZ</sub>	Output disable time from high level	R <sub>L</sub> = 110 Ω, See Figure 13	51		75	ns
t <sub>PLZ</sub>	Output disable time from low level	R <sub>L</sub> = 110 Ω, See Figure 14	18		30	ns

# TYPE SN75176

## DIFFERENTIAL BUS TRANSCEIVER

### RECEIVER SECTION

receiver electrical characteristics over recommended ranges of common-mode input voltage, supply voltage, and operating free-air temperature (unless otherwise noted)

PARAMETER	TEST CONDITIONS	MIN	TYP <sup>†</sup>	MAX	UNIT
V <sub>TH</sub>	Differential-input high-threshold voltage	V <sub>O</sub> = 2.7 V, I <sub>O</sub> = -0.4 mA		0.2	V
V <sub>TL</sub>	Differential-input low-threshold voltage	V <sub>O</sub> = 0.5 V, I <sub>O</sub> = 8 mA	-0.2 <sup>¶</sup>		V
V <sub>T+</sub> - V <sub>T-</sub>	Hysteresis <sup>§</sup>		50		mV
V <sub>IH</sub>	High-level enable input voltage		2		V
V <sub>IL</sub>	Low-level enable input voltage			0.8	V
V <sub>IK</sub>	Enable-input clamp voltage	I <sub>I</sub> = -18 mA		-1.5	V
V <sub>OH</sub>	High-level output voltage	V <sub>ID</sub> = 200 mV, I <sub>OH</sub> = -400 μA, See Figure 10	2.7		V
V <sub>OL</sub>	Low-level output voltage	V <sub>ID</sub> = -200 mV, See Figure 10		0.45 0.5	V
I <sub>OZ</sub>	High-impedance-state output current	V <sub>O</sub> = 0.4 V to 2.4 V		±20	μA
I <sub>I</sub>	Line input current	Other input = 0 V, See Note 4		1 -0.8	mA
I <sub>IH</sub>	High-level enable-input current	V <sub>IH</sub> = 2.7 V		20	μA
I <sub>IL</sub>	Low-level enable-input current	V <sub>IL</sub> = 0.4 V		-100	μA
r <sub>i</sub>	Input resistance		12		kΩ
I <sub>OS</sub>	Short-circuit output current		-15	-85	mA
I <sub>CC</sub>	Supply current (total package)	No load		35 30	mA
				Outputs enabled	
				Outputs disabled	

<sup>†</sup> All typical values are at V<sub>CC</sub> = 5 V, T<sub>A</sub> = 25°C.

<sup>¶</sup> The algebraic convention, where the less-positive (more-negative) limit is designated minimum, is used in this data sheet for common-mode input voltage and threshold voltage levels only.

<sup>§</sup> Hysteresis is the difference between the positive-going input threshold voltage, V<sub>T+</sub>, and the negative-going input threshold voltage, V<sub>T-</sub>. See Figure 4.

NOTE 4: This applies for both power on and power off. Refer to EIA Standard RS-422A for exact conditions.

receiver switching characteristics, V<sub>CC</sub> = 5 V, T<sub>A</sub> = 25°C

PARAMETER	TEST CONDITIONS	MIN	TYP	MAX	UNIT
t <sub>PLH</sub>	Propagation delay time, low-to-high-level output	V <sub>ID</sub> = -2.5 V to 2.5 V,	26	35	ns
t <sub>PHL</sub>	Propagation delay time, high-to-low-level output	C <sub>L</sub> = 15 pF, See Figure 15	27	35	ns
t <sub>PZH</sub>	Output enable time to high level	C <sub>L</sub> = 15 pF, See Figure 16	13	30	ns
t <sub>PZL</sub>	Output enable time to low level		19	30	ns
t <sub>PHZ</sub>	Output disable time from high level		26	35	ns
t <sub>PLZ</sub>	Output disable time from low level	C <sub>L</sub> = 5 pF, See Figure 16	27	35	ns

### TYPICAL CHARACTERISTICS

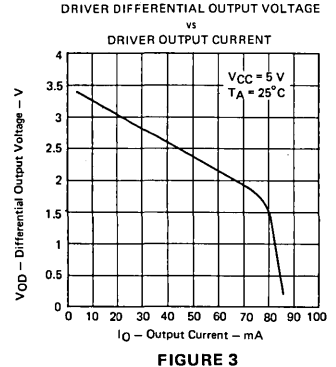
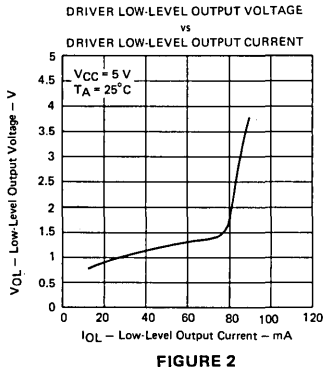
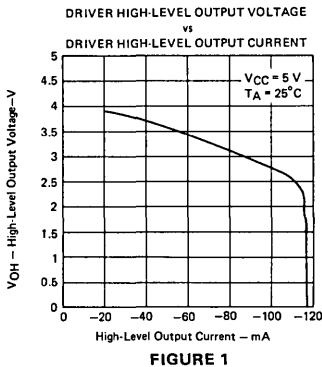

# TYPE SN75176 DIFFERENTIAL BUS TRANSCEIVER

## TYPICAL CHARACTERISTICS

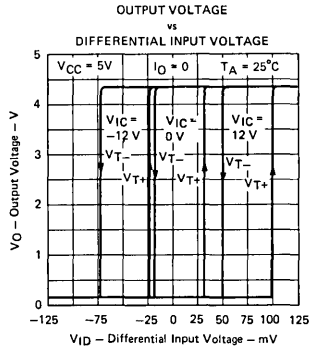

FIGURE 4

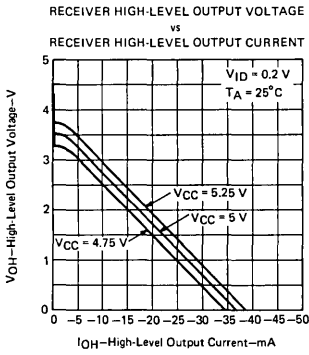

FIGURE 5

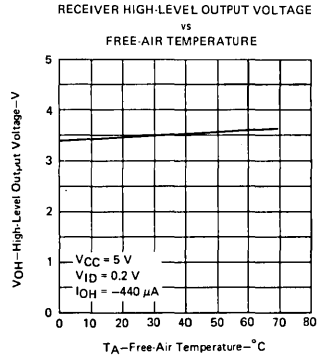

FIGURE 6

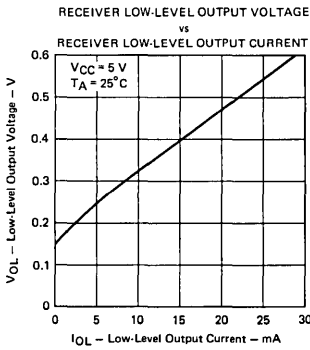

FIGURE 7

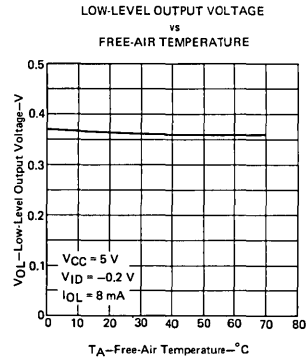

FIGURE 8

5

# TYPE SN75176 DIFFERENTIAL BUS TRANSCEIVER

## PARAMETER MEASUREMENT INFORMATION

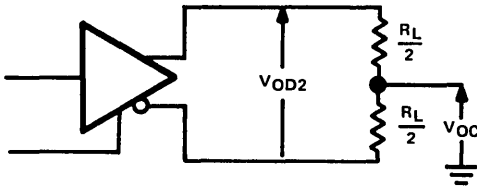

FIGURE 9—DRIVER  $V_{OD}$  AND  $V_{OC}$

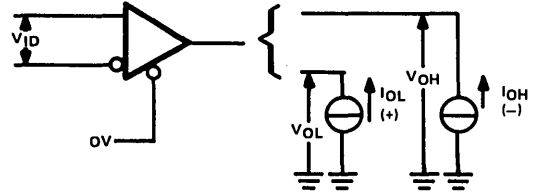
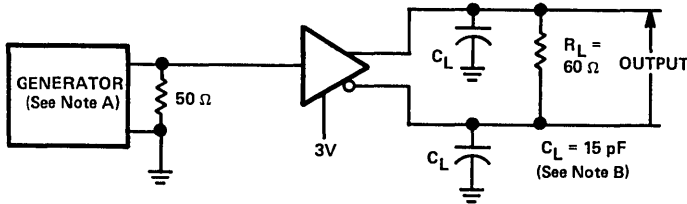
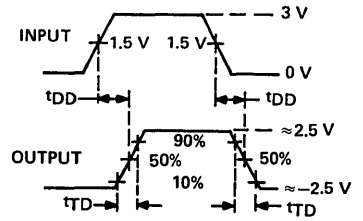

FIGURE 10—RECEIVER  $V_{OH}$  AND  $V_{OL}$

5



TEST CIRCUIT



VOLTAGE WAVEFORMS

FIGURE 11—DRIVER DIFFERENTIAL-OUTPUT DELAY AND TRANSITION TIMES

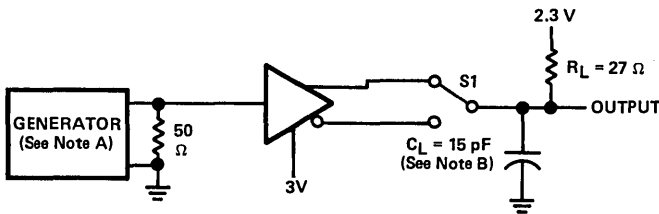

TEST CIRCUIT

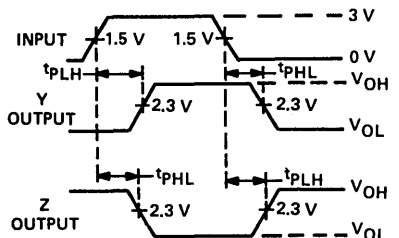

VOLTAGE WAVEFORMS

FIGURE 12—DRIVER PROPAGATION TIMES

NOTES: A. The input pulse is supplied by a generator having the following characteristics: PRR = 1 MHz, 50% duty cycle,  $t_r \leq 6$  ns,  $t_f \leq 6$  ns,  $Z_{out} = 50 \Omega$ .  
B.  $C_L$  includes probe and jig capacitance.

# TYPE SN75176 DIFFERENTIAL BUS TRANSCEIVER

## PARAMETER MEASUREMENT INFORMATION

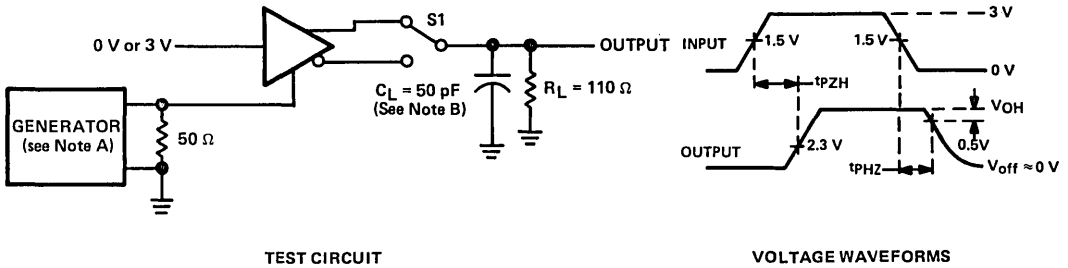

FIGURE 13—DRIVER ENABLE AND DISABLE TIMES

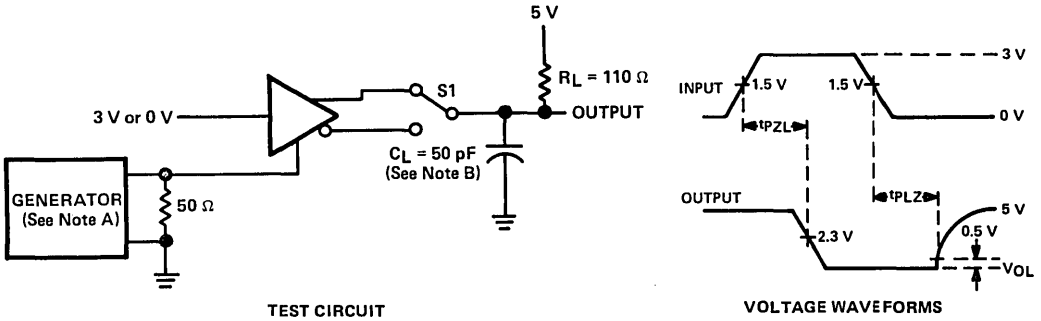

FIGURE 14—DRIVER ENABLE AND DISABLE TIMES

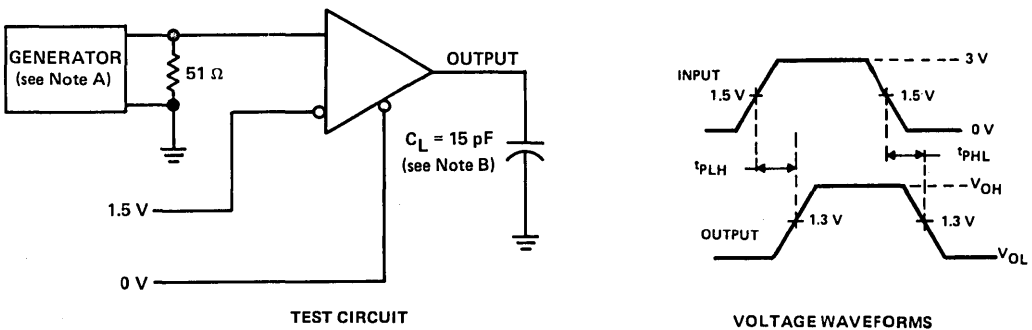

FIGURE 15—RECEIVER PROPAGATION DELAY TIMES

NOTES: A. The input pulse is supplied by a generator having the following characteristics: PRR = 1 MHz, 50% duty cycle,  $t_r < 6$  ns,  $t_f < 6$  ns,  $Z_{out} = 50 \Omega$ .  
 B.  $C_L$  includes probe and jig capacitance.

5

# TYPE SN75176 DIFFERENTIAL BUS TRANSCEIVER

## PARAMETER MEASUREMENT INFORMATION

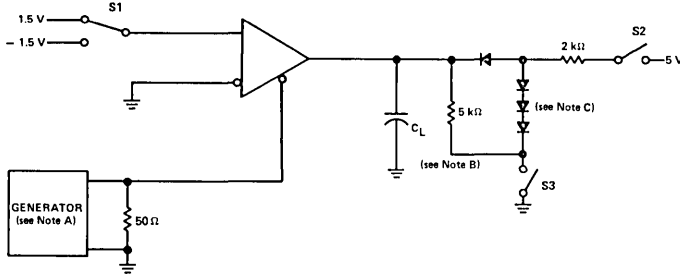

### TEST CIRCUIT

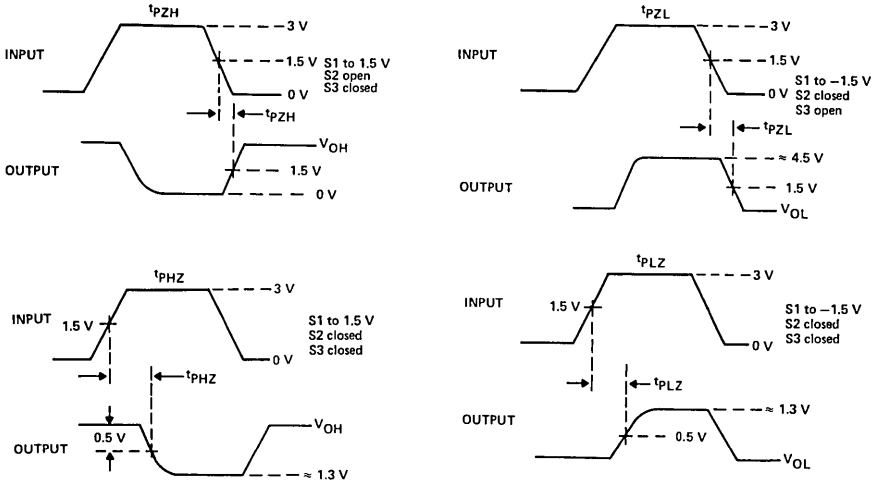

### VOLTAGE WAVEFORMS

- NOTES: A. The input pulse is supplied by a generator having the following characteristics: PRR = 1 MHz, duty cycle  $\approx$  50%,  $t_r = t_f = 6$  ns.  
 B.  $C_L$  includes probe and stray capacitance.  
 C. All diodes are 1N916 or equivalent.

FIGURE 16—RECEIVER ENABLE AND DISABLE TIMES

## TYPICAL APPLICATION

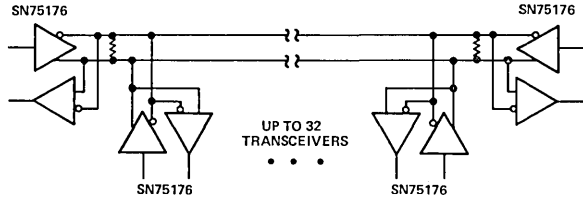

NOTE: The line length should be terminated at both ends in its characteristic impedance. Stubs lengths off the mainline should be kept as short as possible.

FIGURE 17

- Meets EIA Standard RS-422A and CCITT Recommendations V.11 and X.27
- Meets EIA Subcommittee TR30.1 Draft Standard PN1360 (as of April 1980)
- Designed for Multipoint Transmission on Long Bus Lines in Noisy Environments
- 3-State Outputs
- Bus Voltage Range . . . -7 V to 12 V
- Positive and Negative Current Limiting
- Driver Output Capability . . . 60 mA Max
- Driver Thermal Shutdown Protection
- Receiver Input Impedance . . . 12 k $\Omega$  Min
- Receiver Input Sensitivity . . .  $\pm 200$  mV
- Receiver Input Hysteresis . . . 50 mV Typ
- Operates from Single 5-Volt Supply
- Low Power Requirements

### description

The SN75177 and SN75178 differential bus repeaters are monolithic integrated devices each designed for one-way data communication on multipoint bus transmission lines. These devices are designed for balanced transmission bus line applications and meet EIA Standard RS-422A, EIA Subcommittee TR30.1 draft Standard PN1360, and CCITT Recommendations V.11 and X.27. Each device is designed to improve the performance of the data communication over long bus lines. The SN75177 and SN75178 are identical except for the enable inputs, which are complementary, that is, on the SN75177 it is active-high and on the SN75178 it is active-low. These complementary enables allow the devices to be used in pairs for bidirectional communication.

The SN75177 and SN75178 feature positive- and negative-current limiting and three-state outputs for the receiver and driver. The receiver features high input impedance, input hysteresis for increased noise immunity, and input sensitivity of  $\pm 200$  millivolts over a common-mode input voltage range of -12 volts to 12 volts. The driver features thermal shutdown for protection from line fault conditions. Thermal shutdown is designed to occur at a junction temperature of approximately 150 $^{\circ}$  C. The driver is designed to drive current loads up to 60 milliamperes maximum.

The SN75177 and SN75178 are designed for optimum performance when used on transmission buses employing the SN75172 and SN75174 differential line drivers, SN75173 and SN75175 differential line receivers, or SN75176 differential bus transceiver.

SN75177 . . . JG or P  
DUAL-IN-LINE PACKAGE  
(TOP VIEW)

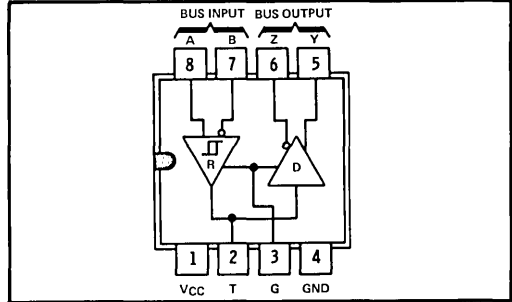

SN75178 . . . JG or P  
DUAL-IN-LINE PACKAGE  
(TOP VIEW)

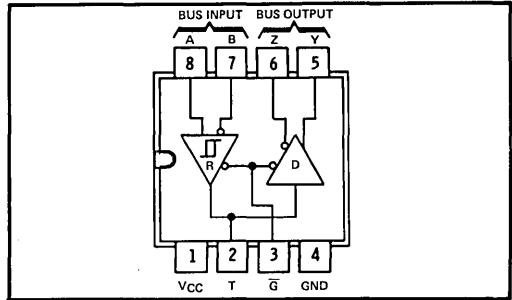

SN75177 FUNCTION TABLE

DIFFERENTIAL INPUTS A-B	ENABLE G	OUTPUTS		
		T	Y	Z
$V_{ID} \geq 0.2$ V	H	H	H	L
$-0.2$ V $< V_{ID} < 0.2$ V	H	?	?	?
$V_{ID} \leq 0.2$ V	H	L	L	H
X	L	Z	Z	Z

SN75178 FUNCTION TABLE

DIFFERENTIAL INPUTS A-B	ENABLE G-bar	OUTPUTS		
		T	Y	Z
$V_{ID} \geq 0.2$ V	L	H	H	L
$-0.2$ V $< V_{ID} < 0.2$ V	L	?	?	?
$V_{ID} \leq 0.2$ V	L	L	L	H
X	H	Z	Z	Z

H = high level, L = low level, ? = indeterminate,  
X = irrelevant, Z = high impedance (off)

# TYPES SN75177, SN75178

## DIFFERENTIAL BUS REPEATERS

### schematics of inputs and outputs

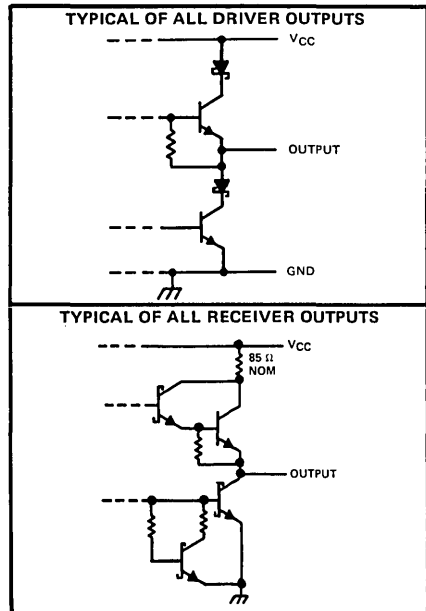
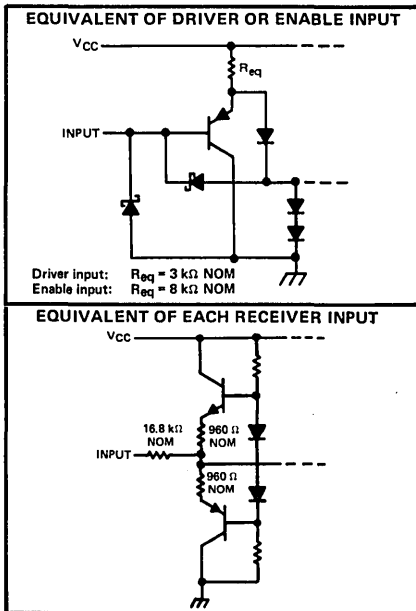

5

### absolute maximum ratings over operating free-air temperature range (unless otherwise noted)

Supply voltage, $V_{CC}$ (see Note 1)	7 V
Voltage at any bus terminal	-10 V to 15 V
Differential input voltage (see Note 2)	$\pm 25$ V
Enable input voltage	5.5 V
Continuous total dissipation at (or below) 25°C free-air temperature (see Note 3): JG Package	830 mW
P Package	1000 mW
Operating free-air temperature range	0°C to 70°C
Storage temperature range	-65°C to 150°C
Lead temperature 1/16 inch (1,6 mm) from case for 60 seconds: JG Package	300°C
Lead temperature 1/16 inch (1,6 mm) from case for 10 seconds: P Package	260°C

- NOTES: 1. All voltage values, except differential input voltage, are with respect to network ground terminal.  
 2. Differential input voltage is measured at the noninverting input with respect to the corresponding inverting input.  
 3. For operation above 25°C free-air temperature, derate the JG package to 528 mW at 70°C at the rate of 6.6 mW/°C and the P package to 640 mW at 70°C at the rate of 8.0 mW/°C. In the JG package, SN75177 and SN75178 chips are glass-mounted.

### recommended operating conditions

	MIN	NOM	MAX	UNIT
Supply voltage, $V_{CC}$	4.75	5	5.25	V
Common-mode input voltage, $V_{IC}$	-7 <sup>†</sup>		12	V
Differential input voltage, $V_{ID}$			$\pm 12$	V
High-level output current, $I_{OH}$	Driver		-60	mA
	Receiver		-400	$\mu$ A
Low-level output current, $I_{OL}$	Driver		60	mA
	Receiver		16	$\mu$ A
Operating free-air temperature, $T_A$	0		70	°C

<sup>†</sup>The algebraic convention, where the less-positive (more-negative) limit is designated minimum, is used in this data sheet for common-mode input voltage and threshold voltage.



# TYPES SN75177, SN75178 DIFFERENTIAL BUS REPEATERS

## DRIVER SECTION

driver electrical characteristics over recommended ranges of supply voltage and operating free-air temperature (unless otherwise noted)

PARAMETER	TEST CONDITIONS		MIN	TYP <sup>†</sup>	MAX	UNIT
V <sub>IH</sub>	High-level input voltage		2			V
V <sub>IL</sub>	Low-level input voltage				0.8	V
V <sub>IK</sub>	Input clamp voltage	I <sub>I</sub> = -18 mA			-1.5	V
V <sub>OH</sub>	High-level output voltage	V <sub>IH</sub> = 2 V, I <sub>OH</sub> = -33 mA		3.7		V
V <sub>OL</sub>	Low-level output voltage	V <sub>IH</sub> = 2 V, I <sub>OL</sub> = 33 mA		1.1		V
V <sub>OD1</sub>	Differential output voltage	I <sub>O</sub> = 0			2V <sub>OD2</sub>	V
V <sub>OD2</sub>	Differential output voltage	R <sub>L</sub> = 100 Ω, See Figure 9	2	2.7		V
		R <sub>L</sub> = 54 Ω, See Figure 9	1.5	2.4		
Δ V <sub>OD</sub>	Change in magnitude of differential output voltage <sup>‡</sup>				±0.2	V
V <sub>OC</sub>	Common-mode output voltage <sup>§</sup>	R <sub>L</sub> = 54 Ω or 100 Ω, See Figure 9			3	V
Δ V <sub>OC</sub>	Change in magnitude of common-mode output voltage <sup>‡</sup>				±0.2	V
I <sub>O</sub>	Output current with power off	V <sub>CC</sub> = 0, V <sub>O</sub> = -7 V to 12			±100	μA
I <sub>OZ</sub>	High-impedance-state output current	V <sub>O</sub> = -7 V to 12 V			±100	μA
I <sub>IH</sub>	High-level input current	V <sub>I</sub> = 2.4 V			20	μA
I <sub>IL</sub>	Low-level input current	V <sub>I</sub> = 0.4 V			-360	μA
I <sub>OS</sub>	Short-circuit output current	V <sub>O</sub> = -7 V			-180	mA
		V <sub>O</sub> = V <sub>CC</sub>			180	
		V <sub>O</sub> = 12 V			500	
I <sub>CC</sub>	Supply current (total package)	No load	Outputs enabled		35	mA
			Outputs disabled		30	

<sup>†</sup> All typical values are at V<sub>CC</sub> = 5 V and T<sub>A</sub> = 25°C.

<sup>‡</sup> Δ|V<sub>OD</sub>| and Δ|V<sub>OC</sub>| are the changes in magnitude of V<sub>OD</sub> and V<sub>OC</sub>, respectively, that occur when the input is changed from a high level to a low level.

<sup>§</sup> In EIA Standard RS-422A, V<sub>OC</sub>, which is the average of the two output voltages with respect to ground, is called output offset voltage, V<sub>OS</sub>.

driver switching characteristics, V<sub>CC</sub> = 5 V, T<sub>A</sub> = 25°C

PARAMETER	TEST CONDITIONS		MIN	TYP	MAX	UNIT
t <sub>DD</sub>	Differential-output delay time	R <sub>L</sub> = 60 Ω, See Figure 11		35	50	ns
t <sub>TD</sub>	Differential-output transition time			50	75	ns
t <sub>PLH</sub>	Propagation delay time, low-to-high-level output	R <sub>L</sub> = 27 Ω, See Figure 12		16	25	ns
t <sub>PHL</sub>	Propagation delay time, high-to-low-level output			44	65	ns
t <sub>pZH</sub>	Output enable time to high level	R <sub>L</sub> = 110 Ω, See Figure 13		60	80	ns
t <sub>pZL</sub>	Output enable time to low level	R <sub>L</sub> = 110 Ω, See Figure 14		30	45	ns
t <sub>PHZ</sub>	Output disable time from high level	R <sub>L</sub> = 110 Ω, See Figure 13		51	75	ns
t <sub>PLZ</sub>	Output disable time from low level	R <sub>L</sub> = 110 Ω, See Figure 14		18	30	ns

# TYPES SN75177, SN75178

## DIFFERENTIAL BUS REPEATERS

### RECEIVER SECTION

receiver electrical characteristics over recommended ranges of common-mode input voltage, supply voltage, and operating free-air temperature (unless otherwise noted)

PARAMETER	TEST CONDITIONS	MIN	TYP <sup>†</sup>	MAX	UNIT
V <sub>TH</sub>	Differential-input high-threshold voltage V <sub>O</sub> = 2.7 V, I <sub>O</sub> = -0.4 mA			0.2	V
V <sub>TL</sub>	Differential-input low-threshold voltage V <sub>O</sub> = 0.5 V, I <sub>O</sub> = 8 mA	-0.2 <sup>‡</sup>			V
V <sub>T+</sub> - V <sub>T-</sub>	Hysteresis <sup>§</sup>		50		mV
V <sub>IH</sub>	High-level enable input voltage		2		V
V <sub>IL</sub>	Low-level enable input voltage			0.8	V
V <sub>IK</sub>	Enable-input clamp voltage I <sub>I</sub> = -18 mA			-1.5	V
V <sub>OH</sub>	High-level output voltage V <sub>ID</sub> = 200 mV, I <sub>OH</sub> = -400 μA, See Figure 10	2.7			V
V <sub>OL</sub>	Low-level output voltage V <sub>ID</sub> = -200 mV, See Figure 10	I <sub>OL</sub> = 8 mA		0.45	V
		I <sub>OL</sub> = 16 mA		0.5	
I <sub>OZ</sub>	High-impedance-state output current V <sub>O</sub> = 0.4 V to 2.4 V			20	μA
				-360	
I <sub>I</sub>	Line input current Other input at 0 V, See Note 4			1	mA
		V <sub>I</sub> = 12 V		-0.8	
I <sub>IH</sub>	High-level enable-input current V <sub>IH</sub> = 2.7 V			20	μA
I <sub>IL</sub>	Low-level enable-input current V <sub>IL</sub> = 0.4 V			-100	μA
r <sub>i</sub>	Input resistance		12		kΩ
I <sub>OS</sub>	Short-circuit output current		-15	-85	mA
I <sub>CC</sub>	Supply current (total package) No load	Outputs enabled		35	mA
		Outputs disabled		30	

<sup>†</sup> All typical values are at V<sub>CC</sub> = 5 V, T<sub>A</sub> = 25°C.

<sup>‡</sup> The algebraic convention, where the less-positive (more-negative) limit is designated minimum, is used in this data sheet for common-mode input voltage and threshold voltage levels only.

<sup>§</sup> Hysteresis is the difference between the positive-going input threshold voltage, V<sub>T+</sub>, and the negative-going input threshold voltage, V<sub>T-</sub>. See Figure 4.

NOTE 4: Refer to EIA standard RS-422A for exact conditions

receiver switching characteristics, V<sub>CC</sub> = 5 V, T<sub>A</sub> = 25°C

PARAMETER	TEST CONDITIONS	MIN	TYP	MAX	UNIT
t <sub>PLH</sub>	Propagation delay time, low-to-high-level output V <sub>ID</sub> = -2.5 V to 2.5 V,		26	35	ns
t <sub>PHL</sub>	Propagation delay time, high-to-low-level output C <sub>L</sub> = 15 pF, See Figure 15		27	35	
t <sub>PZH</sub>	Output enable time to high level C <sub>L</sub> = 15 pF, See Figure 16		13	30	ns
t <sub>PZL</sub>	Output enable time to low level C <sub>L</sub> = 15 pF, See Figure 16		19	30	ns
t <sub>PHZ</sub>	Output disable time from high level C <sub>L</sub> = 5 pF, See Figure 16		26	35	ns
t <sub>PLZ</sub>	Output disable time from low level C <sub>L</sub> = 5 pF, See Figure 16		27	35	ns

### TYPICAL CHARACTERISTICS

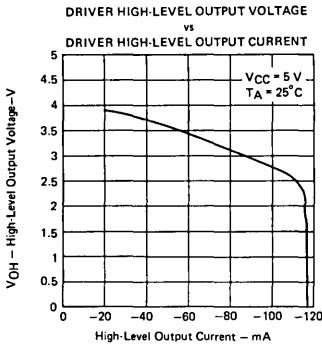

FIGURE 1

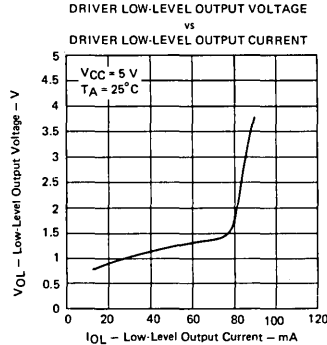

FIGURE 2

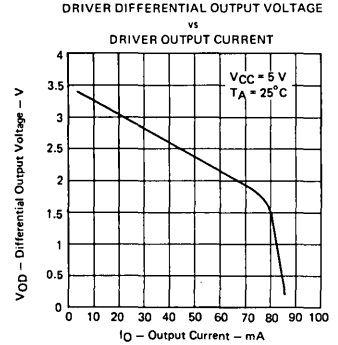

FIGURE 3

# TYPES SN75177, SN75178 DIFFERENTIAL BUS REPEATERS

## TYPICAL CHARACTERISTICS

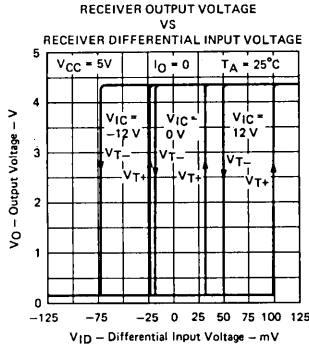

FIGURE 4

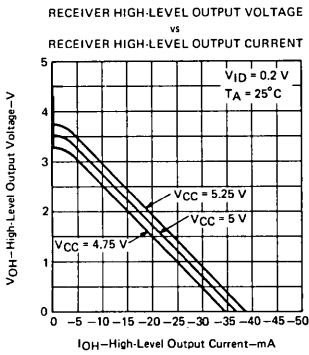

FIGURE 5

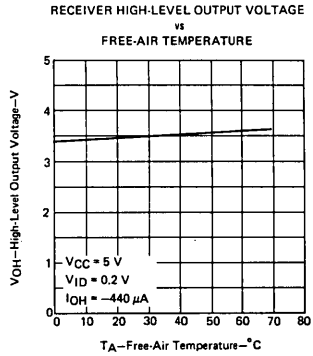

FIGURE 6

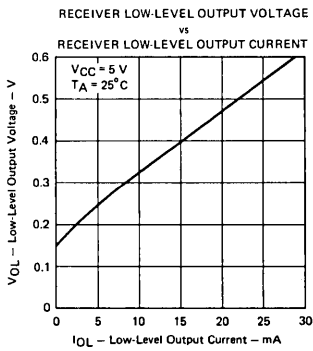

FIGURE 7

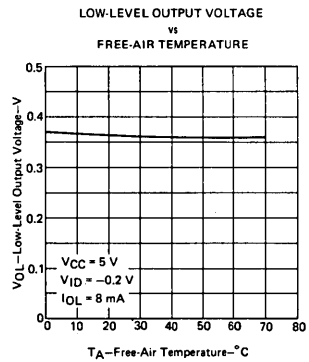

FIGURE 8

# TYPES SN75177, SN75178 DIFFERENTIAL BUS REPEATERS

## PARAMETER MEASUREMENT INFORMATION

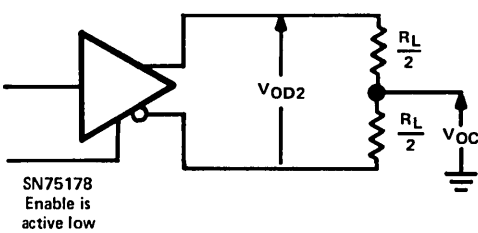

FIGURE 9—DRIVER  $V_{OD}$  AND  $V_{OC}$

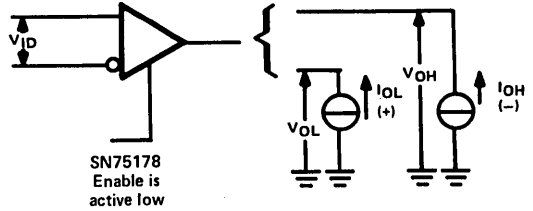

FIGURE 10—RECEIVER  $V_{OH}$  AND  $V_{OL}$

5

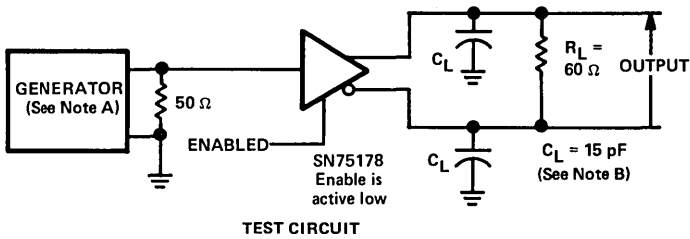

FIGURE 11—DRIVER DIFFERENTIAL-OUTPUT DELAY AND TRANSITION TIMES

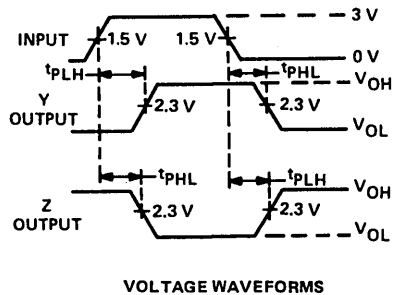
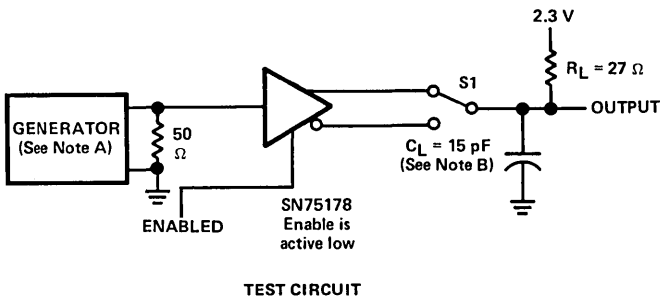
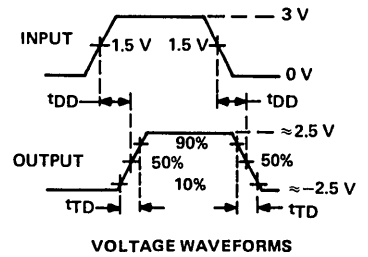

FIGURE 12—DRIVER PROPAGATION TIMES

NOTES: A. The input pulse is supplied by a generator having the following characteristics: PRR = 1 MHz, 50% duty cycle,  $t_r < 6 \text{ ns}$ ,  $t_f < 6 \text{ ns}$ ,  $Z_{out} = 50 \Omega$ .

B.  $C_L$  includes probe and jig capacitance.

# TYPES SN75177, SN75178 DIFFERENTIAL BUS REPEATERS

## PARAMETER MEASUREMENT INFORMATION

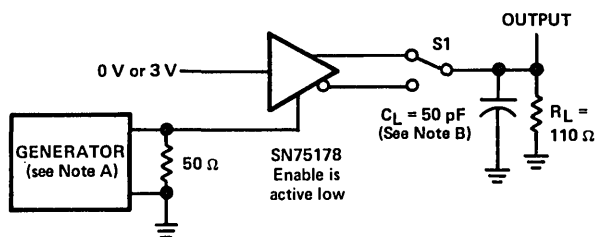

TEST CIRCUIT

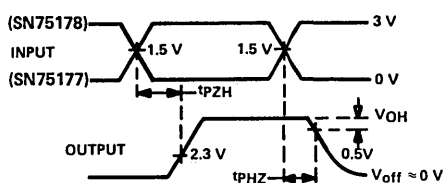

VOLTAGE WAVEFORMS

FIGURE 13—DRIVER ENABLE AND DISABLE TIMES ( $t_{pZH}$ ,  $t_{pHZ}$ )

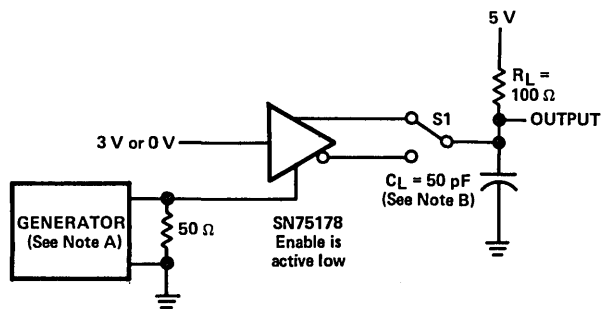

TEST CIRCUIT

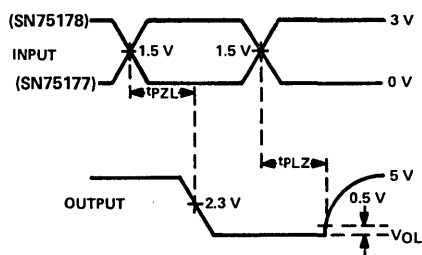

VOLTAGE WAVEFORMS

FIGURE 14—DRIVER ENABLE AND DISABLE TIMES ( $t_{pZL}$ ,  $t_{pLZ}$ )

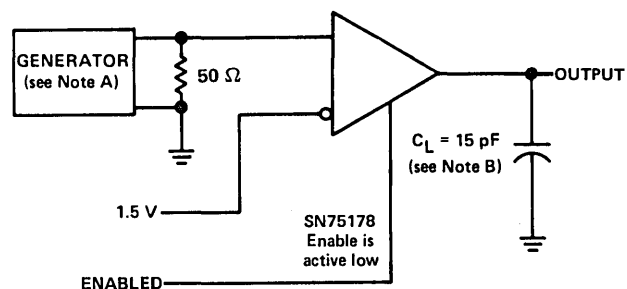

TEST CIRCUIT

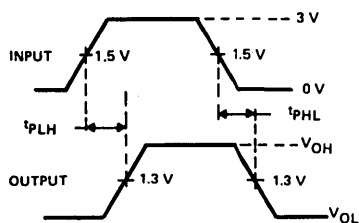

VOLTAGE WAVEFORMS

FIGURE 15—RECEIVER PROPAGATION DELAY TIMES

- NOTES: A. The input pulse is supplied by a generator having the following characteristics: PRR = 1 MHz, 50% duty cycle,  $t_r \leq 6$  ns,  $t_f \leq 6$  ns,  $Z_{out} = 50 \Omega$ .  
B.  $C_L$  includes probe and jig capacitance.

# TYPES SN75177, SN75178 DIFFERENTIAL BUS REPEATERS

## PARAMETER MEASUREMENT INFORMATION

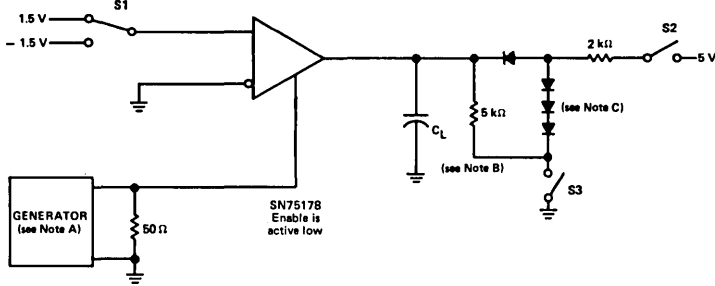

## TEST CIRCUIT

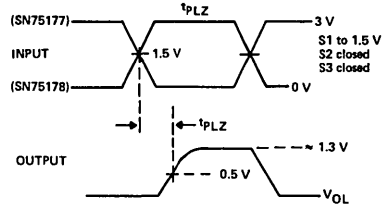
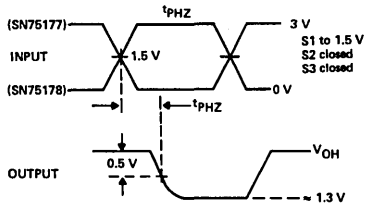
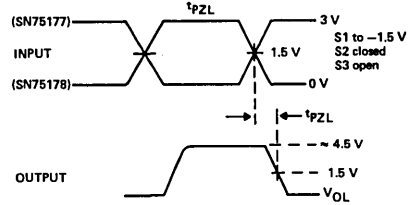
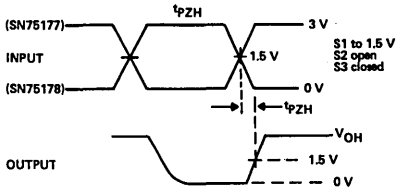

## VOLTAGE WAVEFORMS

- NOTES: A. The input pulse is supplied by a generator having the following characteristics: PRR = 1 MHz, duty cycle  $\approx$  50%,  $t_r = t_f = 6$  ns.  
 B.  $C_L$  includes probe and jig capacitance.  
 C. All diodes are 1N916 or equivalent.

FIGURE 17—RECEIVER ENABLE AND DISABLE TIMES

## TYPICAL APPLICATION

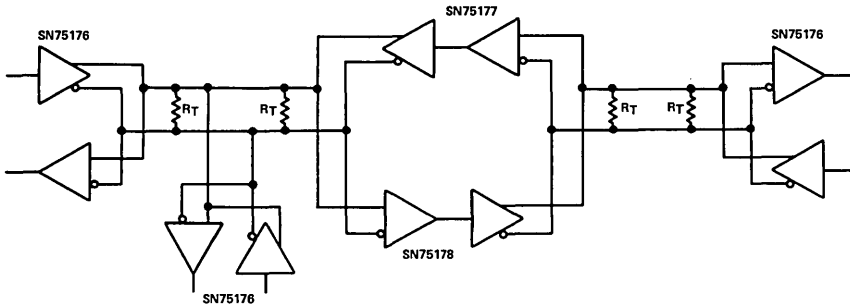

- NOTE: The line should be terminated at both ends in its characteristic impedance. Stub lengths off the main line should be kept as short as possible.

FIGURE 18

# INTERFACE CIRCUITS

# TYPES SN55182, SN75182, SN55183, SN75183 DUAL DIFFERENTIAL RECEIVERS AND DRIVERS

BULLETIN NO. DL-S 11767, OCTOBER 1972—REVISED JANUARY 1977

## LINE CIRCUITS featuring

- Single 5-V Supply
- Differential Line Operation
- Dual Channels
- TTL/DTL Compatibility

### additional features of SN55182 and SN75182 line receivers

- Designed to be Interchangeable with National Semiconductor DS7820A and DS8820A
- $\pm 15$  V Common-Mode Input Voltage Range
- $\pm 15$  V Differential Input Voltage Range
- Individual Channel Strobes
- Built-In Optional Line-Termination Resistor
- Individual Frequency Response Controls

### additional features of SN55183 and SN75183 line drivers

- Designed to be Interchangeable with National Semiconductor DS7830 and DS8830
- Short-circuit Protection of Outputs
- Output Clamp Diodes to Terminate Line Transients
- High-Current Outputs
- Quad Inputs
- Single-Ended or Differential AND/NAND Outputs

### description

The SN55182 and SN75182 dual differential line receivers are designed to sense small differential signals in the presence of large common-mode noise. These devices give TTL compatible output signals as a function of the polarity of the differential input voltage. The frequency response of each channel may be easily controlled by a single external capacitor to provide immunity to differential noise spikes. The output goes to a high level when the inputs are open-circuited. A strobe input is provided which, when in the low level, disables the receiver and forces the output to a high level.

The SN55183 and SN75183 dual differential line drivers are designed to provide differential output signals with high-current capability for driving balanced lines, such as twisted-pair, at normal line impedances without high power dissipation. These devices may be used as TTL expander/phase splitters as the output stages are similar to TTL totem-pole outputs.

Both the driver and receiver are of monolithic single-chip construction, and both halves of the dual circuits use common power supply and ground terminals.

The SN55182 and SN55183 are characterized for operation over the full military temperature range of  $-55^{\circ}\text{C}$  to  $125^{\circ}\text{C}$  and the SN75182 and SN75183 are characterized for operation from  $0^{\circ}\text{C}$  to  $70^{\circ}\text{C}$ . Both devices are available in either the ceramic (J) or plastic (N) dual-in-line package.

## CONTENTS

Line Receivers	Page
Schematic, Maximum Ratings, and Recommended Operating Conditions . . . . .	5-224
Electrical Characteristics and Switching Characteristics . . . . .	5-225
Parameter Measurement Information . . . . .	5-226
Typical Characteristics . . . . .	5-226
Line Drivers	
Schematic, Maximum Ratings, and Recommended Operating Conditions . . . . .	5-229
Electrical Characteristics and Switching Characteristics . . . . .	5-230
Parameter Measurement Information . . . . .	5-231
Typical Characteristics . . . . .	5-231
Typical Application Data . . . . .	5-233

# TYPES SN55182, SN75182

## DUAL DIFFERENTIAL LINE RECEIVERS

schematic (each receiver)

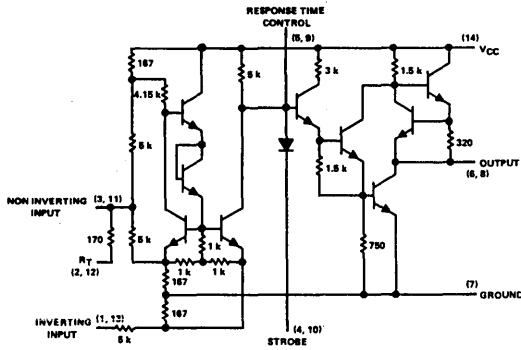

Resistor values shown are nominal and in ohms.

logic

FUNCTION TABLE

STROBE	DIFF INPUT	OUTPUT
L	X	H
H	H	H
H	L	L

H =  $V_i \geq V_{IH}$  min or  $V_{iD}$  more positive than  $V_{TH}$  max

L =  $V_i < V_{iL}$  max or  $V_{iD}$  more negative than  $V_{TL}$  max

X = Irrelevant

JORN DUAL-IN-LINE PACKAGE  
(TOP VIEW)

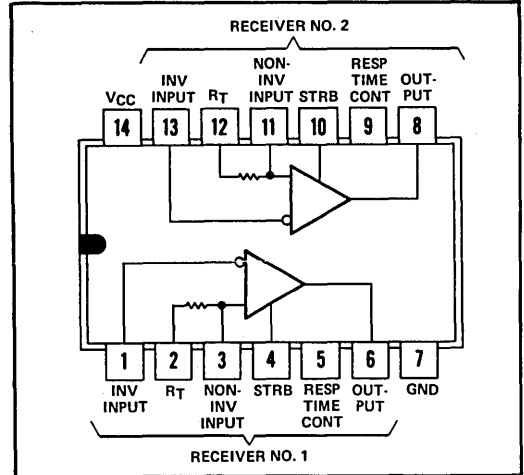

5

absolute maximum ratings over operating free-air temperature range (unless otherwise noted)

Supply voltage, $V_{CC}$ (see Note 1)	8 V
Common-mode input voltage	$\pm 20$ V
Differential input voltage (see Note 2)	$\pm 20$ V
Strobe input voltage	8 V
Output sink current	50 mA
Continuous total dissipation at (or below) 70°C free-air temperature (see Note 3)	600 mW
Operating free-air temperature range: SN55182	-55°C to 125°C
SN75182	0°C to 70°C
Storage temperature range	-65°C to 150°C
Lead temperature 1/16 inch from case for 60 seconds: J package	300°C
Lead temperature 1/16 inch from case for 10 seconds: N package	260°C

- NOTES: 1. All voltage values, except differential voltages, are with respect to the network ground terminal.  
 2. Differential voltage values are at the noninverting terminal with respect to the inverting terminal.  
 3. For operation of SN55182 above 70°C free-air temperature, refer to Dissipation Derating Curves in the Thermal Information section, which starts on page 2-1. In the J package, these chips are glass-mounted.

recommended operating conditions

	SN55182			SN75182			UNIT
	MIN	NOM	MAX	MIN	NOM	MAX	
Supply voltage, $V_{CC}$	4.5	5	5.5	4.5	5	5.5	V
Common-mode input voltage, $V_{iC}$	$\pm 15$			$\pm 15$			
High-level output current, $I_{OH}$	-400			-400			$\mu$ A
Low-level output current, $I_{OL}$	16			16			mA
Operating free-air temperature, $T_A$	-55		125	0		70	°C



## TYPES SN55182, SN75182 DUAL DIFFERENTIAL LINE RECEIVERS

electrical characteristics over recommended ranges of  $V_{CC}$ ,  $V_{IC}$ , and operating free-air temperature (unless otherwise noted)

PARAMETER		TEST CONDITIONS†		MIN	TYP‡	MAX	UNIT	
$V_{TH}$	Differential input high-threshold voltage	$V_O = 2.5\text{ V}$ ,	$V_{IC} = -3\text{ V to }3\text{ V}$			0.5	V	
		$I_{OH} = -400\ \mu\text{A}$	$V_{IC} = -15\text{ V to }15\text{ V}$			1		
$V_{TL}$	Differential input low-threshold voltage	$V_O = 0.4\text{ V}$ ,	$V_{IC} = -3\text{ V to }3\text{ V}$			-0.5	V	
		$I_{OL} = 16\text{ mA}$ ,	$V_{IC} = -15\text{ V to }15\text{ V}$			-1		
$V_{IH(\text{strobe})}$	High-level strobe input voltage			2.1		5.5	V	
$V_{IL(\text{strobe})}$	Low-level strobe input voltage			0		0.9	V	
$V_{OH}$	High-level output voltage	$V_{ID} = 1\text{ V}$ ,	$V_{\text{strobe}} = 2.1\text{ V}$ ,	2.5	4.2	5.5	V	
		$I_{OH} = -400\ \mu\text{A}$						
$V_{OL}$	Low-level output voltage	$V_{ID} = -1\text{ V}$ ,	$V_{\text{strobe}} = 0.4\text{ V}$ ,	2.5	4.2	5.5	V	
		$I_{OH} = -400\ \mu\text{A}$						
$V_{OL}$	Low-level output voltage	$V_{ID} = -1\text{ V}$ ,	$V_{\text{strobe}} = 2.1\text{ V}$ ,		0.25	0.4	V	
		$I_{OL} = 16\text{ mA}$						
$I_i$	Input current	Inverting input	$V_{IC} = 15\text{ V}$		3	4.2	mA	
			$V_{IC} = 0\text{ V}$		0	0.5		
			$V_{IC} = -15\text{ V}$		-3	-4.2		
		Noninverting input	$V_{IC} = 15\text{ V}$		5	7	mA	
			$V_{IC} = 0\text{ V}$		-1	-1.4		
			$V_{IC} = -15\text{ V}$		-7	-9.8		
$I_{SH}$	High-level strobe current	$V_{\text{strobe}} = 5.5\text{ V}$				5	$\mu\text{A}$	
$I_{SL}$	Low-level strobe current	$V_{\text{strobe}} = 0$				-1	-1.4	mA
$r_i$	Input resistance	Inverting input		3.6	5		k $\Omega$	
		Noninverting input		1.8	2.5		k $\Omega$	
$R_T$	Line terminating resistance	$T_A = 25^\circ\text{C}$		120	170	250	$\Omega$	
$I_{OS}$	Short-circuit output current	$V_{CC} = 5.5\text{ V}$ ,	$V_O = 0$	-2.8	-4.5	-6.7	mA	
$I_{CC}$	Supply current (average per receiver)	$V_{IC} = 15\text{ V}$ ,	$V_{ID} = -1\text{ V}$		4.2	6	mA	
		$V_{IC} = 0$ ,	$V_{ID} = -0.5\text{ V}$		6.8	10.2		
		$V_{IC} = -15\text{ V}$ ,	$V_{ID} = -1\text{ V}$		9.4	14		

† Unless otherwise noted,  $V_{\text{strobe}} \geq 2.1\text{ V}$  or open.

‡ All typical values are at  $V_{CC} = 5\text{ V}$ ,  $V_{IC} = 0$ , and  $T_A = 25^\circ\text{C}$ .

switching characteristics,  $V_{CC} = 5\text{ V}$ ,  $T_A = 25^\circ\text{C}$

PARAMETER	TEST CONDITIONS	MIN	TYP	MAX	UNIT
$t_{PLH(D)}$	Propagation delay time, low-to-high-level output from differential input		18	40	ns
$t_{PHL(D)}$	Propagation delay time, high-to-low-level output from differential input		31	45	ns
$t_{PLH(S)}$	Propagation delay time, low-to-high-level output from strobe input		9	30	ns
$t_{PHL(S)}$	Propagation delay time, high-to-low-level output from strobe input		15	25	ns

$R_L = 400\ \Omega$ ,  
 $C_L = 15\text{ pF}$ ,  
See Figure 1

**TEXAS INSTRUMENTS**  
INCORPORATED

POST OFFICE BOX 225012 • DALLAS, TEXAS 75265

5-225

5

# TYPES SN55182, SN75182 DUAL DIFFERENTIAL LINE RECEIVERS

## PARAMETER MEASUREMENT INFORMATION

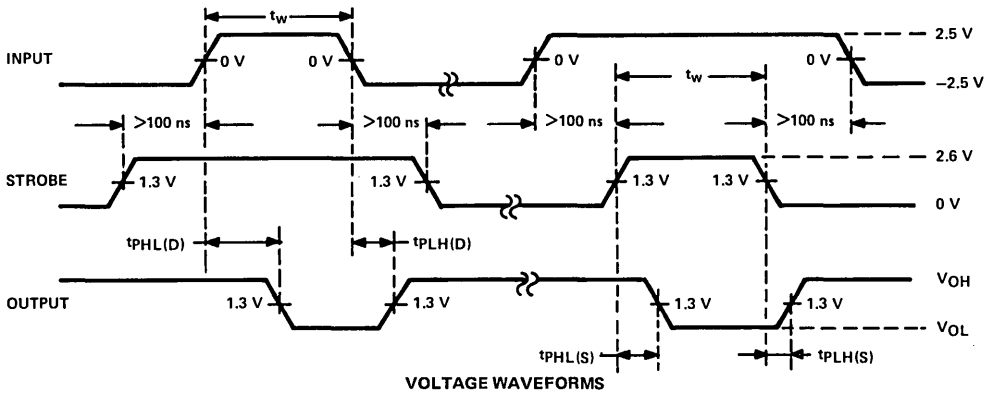
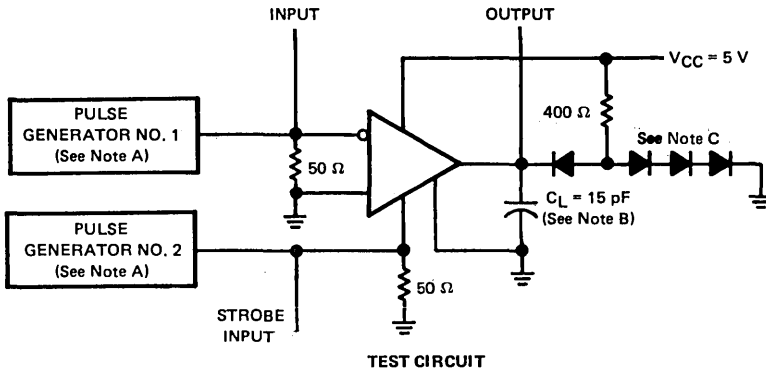

- NOTES: A. The pulse generators have the following characteristics:  $Z_O = 50 \Omega$ ,  $t_r = 10 \text{ ns}$ ,  $t_f = 10 \text{ ns}$ ,  $t_w = 0.5 \pm 0.1 \mu\text{s}$ ,  $\text{PRR} = 1 \text{ MHz}$ .  
 B.  $C_L$  includes probe and jig capacitance.  
 C. All diodes are 1N3064 or equivalent.

FIGURE 1—PROPAGATION DELAY TIMES  
TYPICAL CHARACTERISTICS

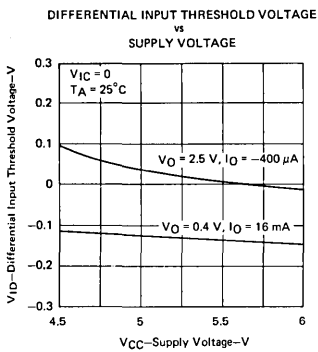

FIGURE 2

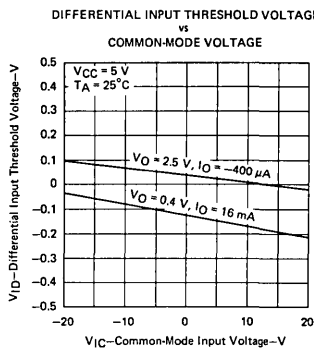

FIGURE 3

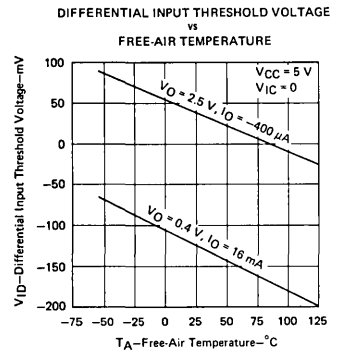

FIGURE 4

# TYPES SN55182, SN75182 DUAL DIFFERENTIAL LINE RECEIVERS

## TYPICAL CHARACTERISTICS

OUTPUT VOLTAGE  
vs  
FREE-AIR TEMPERATURE

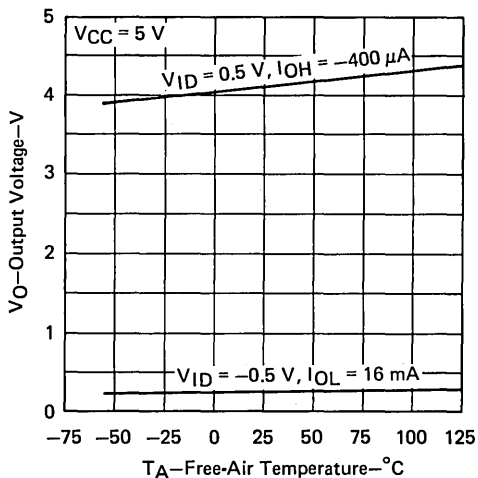

FIGURE 5

VOLTAGE TRANSFER CHARACTERISTICS

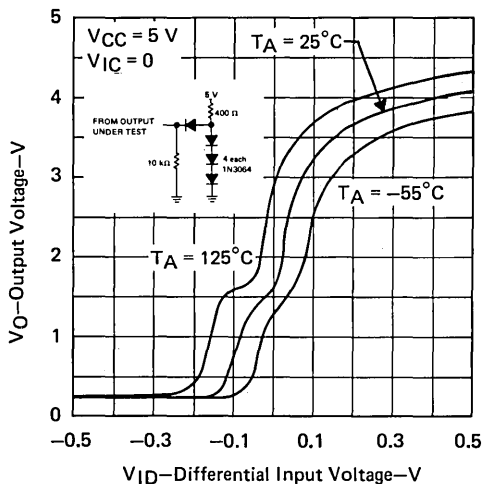

FIGURE 6

INPUT CURRENT  
vs  
INPUT VOLTAGE

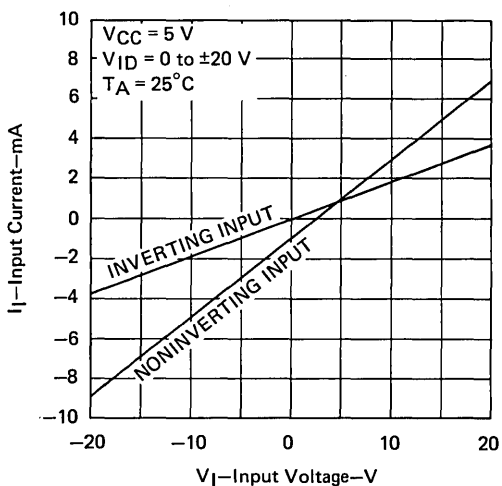

FIGURE 7

TERMINATING RESISTANCE  
vs  
FREE-AIR TEMPERATURE

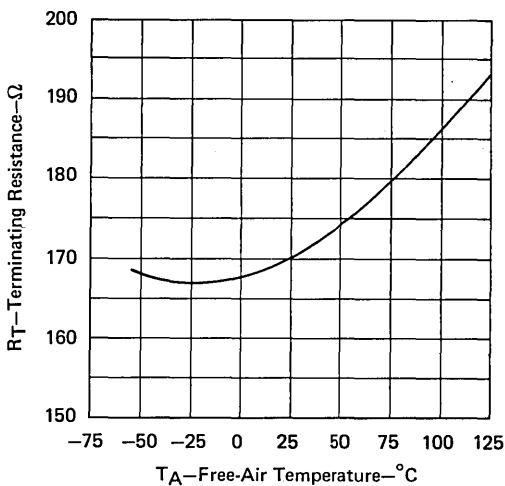

FIGURE 8

5

# TYPES SN55182, SN75182 DUAL DIFFERENTIAL LINE RECEIVERS

## TYPICAL CHARACTERISTICS

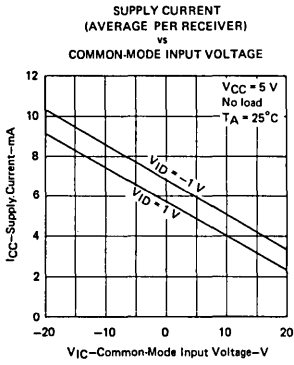

FIGURE 9

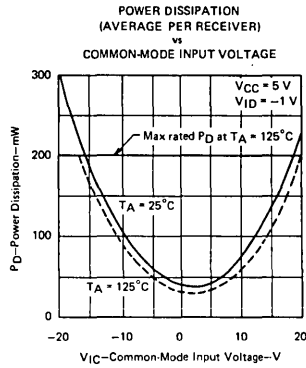

FIGURE 10

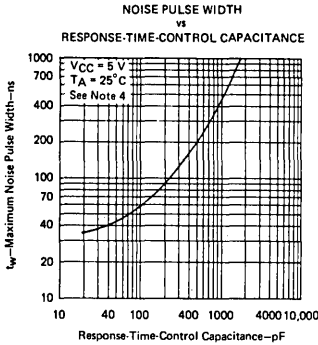
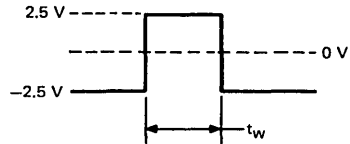

FIGURE 11



INPUT PULSE FOR FIGURE 11

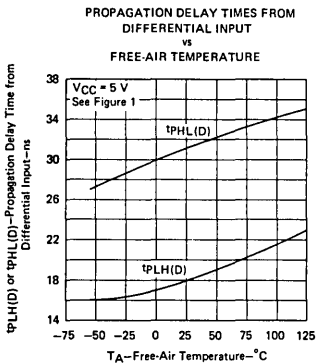

FIGURE 12

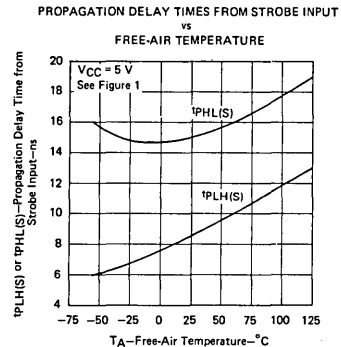
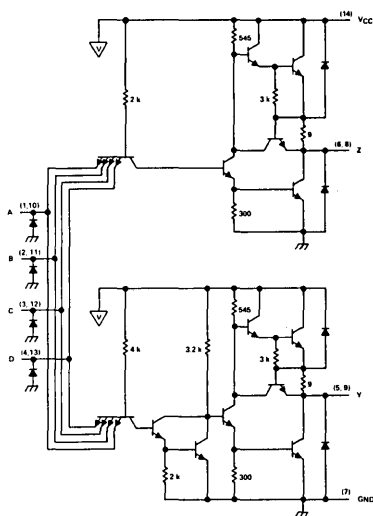

FIGURE 13

NOTE 4: Figure 11 shows the maximum width of the illustrated pulse that can be applied differentially without the output changing from the low to high level.

# TYPES SN55183, SN75183 DUAL DIFFERENTIAL LINE DRIVERS

## schematic (each driver)



Resistor values shown are nominal and in ohms.

$\nabla$  . . .  $V_{CC}$  bus

J OR N DUAL-IN-LINE PACKAGE  
(TOP VIEW)

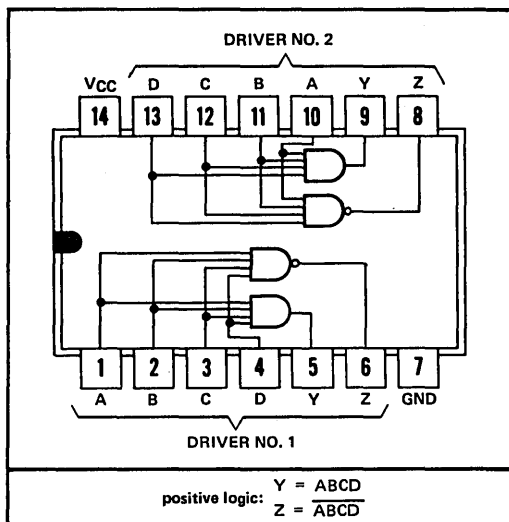

## absolute maximum ratings over operating free-air temperature range (unless otherwise noted)

Supply voltage, $V_{CC}$ (see Note 1)	7 V
Input voltage	5.5 V
Duration of output short-circuit (see Note 2)	1 s
Continuous total power dissipation at (or below) 70°C free-air temperature (see Note 3)	600 mW
Operating free-air temperature range, SN55183	-55°C to 125°C
SN75183	0°C to 70°C
Storage temperature range	-65°C to 150°C
Lead temperature 1/16 inch from case for 60 seconds: J package	300°C
Lead temperature 1/16 inch from case for 10 seconds: N package	260°C

- NOTES: 1. All voltage values, except differential voltages, are with respect to network ground terminal.  
 2. Not more than one output should be shorted to ground at a time.  
 3. For operation of SN55183 above 70°C free-air temperature, refer to Dissipation Derating Curves in the Thermal Information section, which starts on page 2-1. In the J package, these chips are glass-mounted.

## recommended operating conditions

	SN55183			SN75183			UNIT
	MIN	NOM	MAX	MIN	NOM	MAX	
Supply voltage, $V_{CC}$	4.5	5	5.5	4.75	5	5.25	V
High-level output current, $I_{OH}$			-40			-40	mA
Low-level output current, $I_{OL}$			40			40	mA
Operating free-air temperature, $T_A$	-55		125	0		70	°C

# TYPES SN55183, SN75183

## DUAL DIFFERENTIAL LINE DRIVERS

electrical characteristics over recommended ranges of  $V_{CC}$  and operating free-air temperature (unless otherwise noted)

PARAMETER		TEST CONDITIONS	MIN	TYP†	MAX	UNIT
$V_{IH}$	High-level input voltage		2			V
$V_{IL}$	Low-level input voltage				0.8	V
$V_{OH}$	High-level output voltage	$V_{IH} = 2\text{ V}, I_{OH} = -0.8\text{ mA}$	2.4			V
$V_{OL}$	Low-level output voltage		$V_{IH} = 2\text{ V}, I_{OH} = -40\text{ mA}$	1.8	3.3	
		$V_{IL} = 0.8\text{ V}, I_{OL} = 32\text{ mA}$		0.2		
$V_{OH}$	High-level output voltage	$V_{IL} = 0.8\text{ V}, I_{OH} = -0.8\text{ mA}$	2.4			V
			$V_{IL} = 0.8\text{ V}, I_{OH} = -40\text{ mA}$	1.8	3.3	
$V_{OL}$	Low-level output voltage	$V_{IH} = 2\text{ V}, I_{OL} = 40\text{ mA}$		0.2		V
				0.22	0.4	
$I_{IH}$	High-level input current	$V_{IH} = 2.4\text{ V}$			120	$\mu\text{A}$
$I_I$	Input current at maximum input voltage	$V_{IH} = 5.5\text{ V}$			2	mA
$I_{IL}$	Low-level input current	$V_{IL} = 0.4\text{ V}$			-4.8	mA
$I_{OS}$	Short-circuit output current §	$V_{CC} = 5\text{ V}, T_A = 125^\circ\text{C}$	-40	-100	-120	mA
$I_{CC}$	Supply current (average per driver)	$V_{CC} = 5\text{ V},$ All inputs at 5 V, No load		10	18	mA

† All typical values are at  $V_{CC} = 5\text{ V}, T_A = 25^\circ\text{C}$ .

§ Not more than one output should be shorted to ground at a time, and duration of the short-circuit should not exceed one second.

switching characteristics,  $V_{CC} = 5\text{ V}, T_A = 25^\circ\text{C}$

PARAMETER		TEST CONDITIONS	MIN	TYP	MAX	UNIT
$t_{PLH}$	Propagation delay time, low-to-high-level Y output	$C_L = 15\text{ pF},$ See Figure 14(a)		8	12	ns
$t_{PHL}$	Propagation delay time, high-to-low-level Y output			12	18	
$t_{PLH}$	Propagation delay time, low-to-high-level Z output	$C_L = 15\text{ pF},$ See Figure 14(a)		6	12	ns
$t_{PHL}$	Propagation delay time, high-to-low-level Z output			6	8	
$t_{PLH}$	Propagation delay time, low-to-high-level differential output	$Z_L = 100\ \Omega$ in series with 5000 pF, See Figure 14(b)		9	16	ns
$t_{PHL}$	Propagation delay time, high-to-low-level differential output			8	16	

# TYPES SN55183, SN75183 DUAL DIFFERENTIAL LINE DRIVERS

## PARAMETER MEASUREMENT INFORMATION

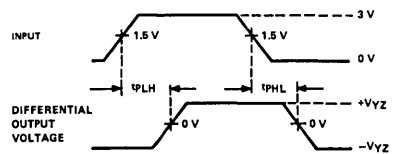
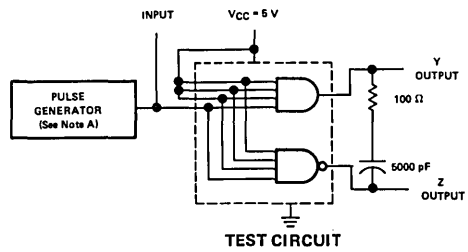
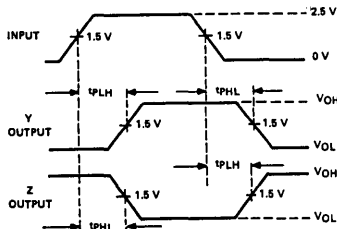
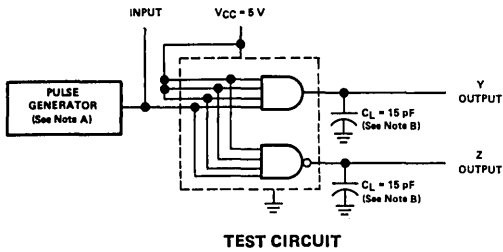

- NOTES: A. The pulse generator has the following characteristics:  $Z_O = 50 \Omega$ ,  $t_r = 10 \text{ ns}$ ,  $t_f = 10 \text{ ns}$ ,  $t_W = 0.5 \mu\text{s}$ ,  $\text{PRR} = 1 \text{ MHz}$ .  
B.  $C_L$  includes probe and jig capacitance.  
C. Waveforms are monitored on an oscilloscope with  $R_{in} > 1 \text{ M}\Omega$ .

FIGURE 14—PROPAGATION DELAY TIMES

## TYPICAL CHARACTERISTICS

THRESHOLD VOLTAGE  
VS  
FREE-AIR TEMPERATURE

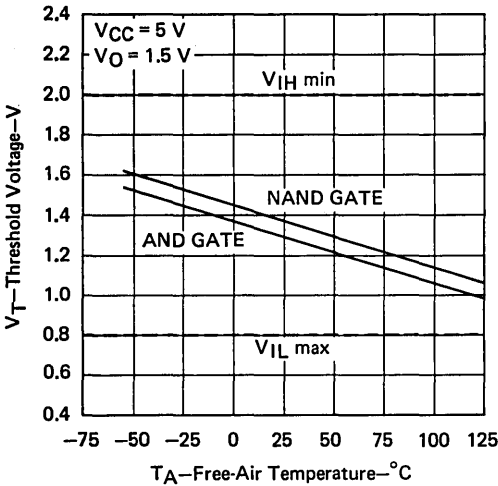

HIGH-LEVEL OUTPUT VOLTAGE  
VS  
OUTPUT CURRENT

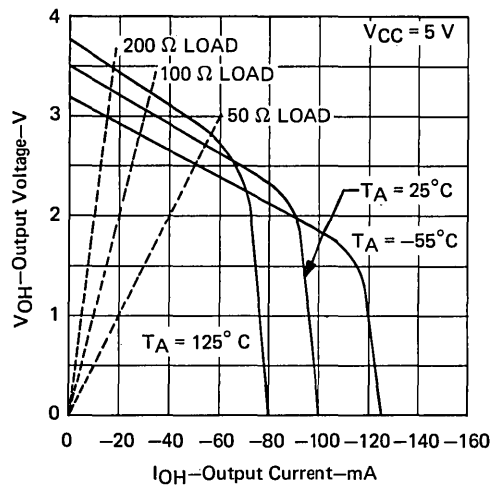

TEXAS INSTRUMENTS  
INCORPORATED

POST OFFICE BOX 225012 • DALLAS, TEXAS 75265

# TYPES SN55183, SN75183 DUAL DIFFERENTIAL LINE DRIVERS

## TYPICAL CHARACTERISTICS

DIFFERENTIAL OUTPUT VOLTAGE  
vs  
DIFFERENTIAL OUTPUT CURRENT

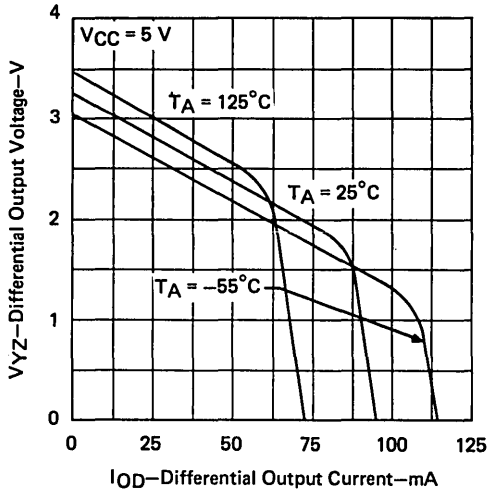

FIGURE 17

LOW-LEVEL OUTPUT VOLTAGE  
vs  
OUTPUT CURRENT

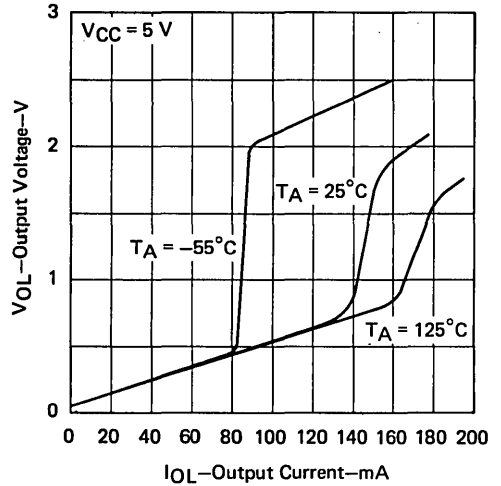

FIGURE 18

PROPAGATION DELAY TIME OF  
DIFFERENTIAL OUTPUT  
vs  
FREE-AIR TEMPERATURE

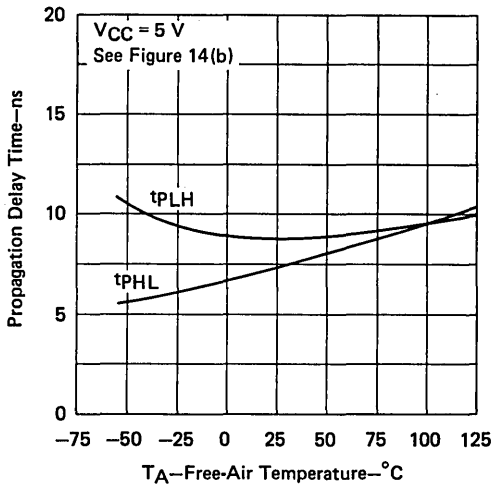

FIGURE 19

TOTAL POWER DISSIPATION  
(BOTH DRIVERS)  
vs  
FREQUENCY

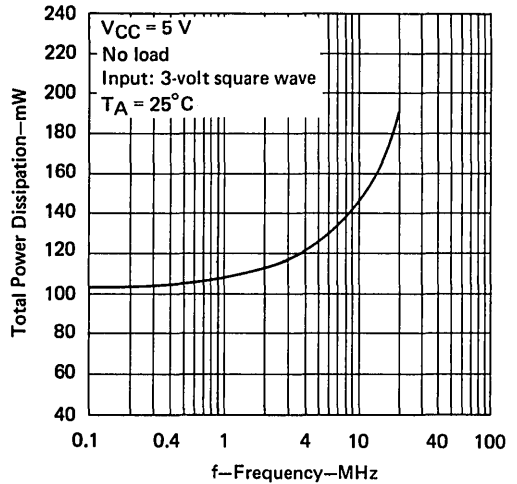
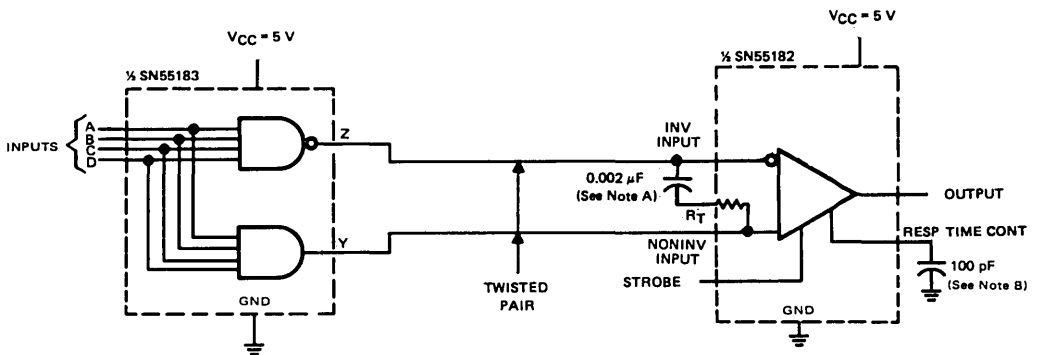

FIGURE 20



# TYPES SN55182, SN75182, SN55183, SN75183 DUAL DIFFERENTIAL RECEIVERS AND DRIVERS

## TYPICAL APPLICATION DATA



5

NOTES: A. When the inputs are open-circuited, the output will be high. A capacitor may be used for dc isolation of the line-terminating resistor. At the frequency of operation, the impedance of the capacitor should be relatively small.

Example: let  $f = 5 \text{ MHz}$   
 $C = 0.002 \mu\text{F}$

$$Z_C = \frac{1}{2\pi f C} = \frac{1}{2\pi (5 \times 10^6) (0.002 \times 10^{-6})}$$

$$Z_C \approx 16 \Omega$$

B. Use of a capacitor to control response time is optional.

FIGURE 21—TRANSMISSION OF DIGITAL DATA OVER TWISTED-PAIR LINE

## FUTURE PRODUCTS TO BE ANNOUNCED

## TYPE SN75186 QUADRUPLE LINE DRIVER

OCTOBER 1980

- Meets EIA Standards RS-232C and RS-423A
- Wide Supply Voltage Range . . .  $\pm 7.5$  V to  $\pm 15$  V
- Low Supply Current . . . 4.5 mA Max per Channel
- Wave Shaping with External Resistors
- Inputs Compatible with TTL and CMOS
- Outputs at High Impedance when Power Is Off
- Positive- and Negative-Current Limiting
- SN75156 is Dual Version in 8-Pin Package

5

description

The SN75186 consists of two pairs of single-ended line drivers designed to meet the requirements of EIA Standards RS-232C and RS-423A, CCITT Recommendations V.10, V.28, and X.26, and Federal Standard FIPS 1030. This device maintains regulated high and low output levels of 5.5 volts and  $-5.5$  volts, respectively, over a wide range of power supply voltages. A high output impedance is maintained without the use of an external blocking diode. The output transition time of each pair of drivers can be adjusted from 1 microsecond to 100 microseconds by means of an external resistor at the waveshaping (WS) pin.

JORN PACKAGE  
(TOP VIEW)

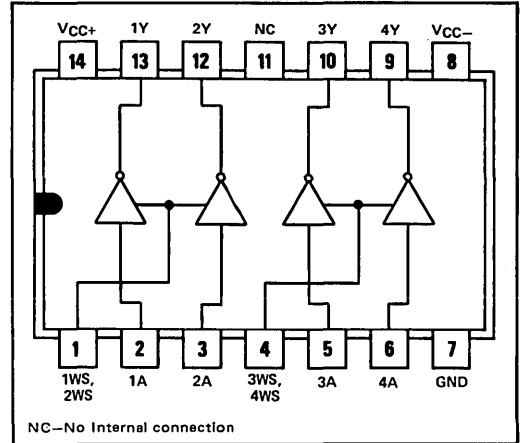

### PRODUCT PREVIEW

5-234

This document contains information on a product under development. Texas Instruments reserves the right to change or discontinue this product without notice.

TEXAS INSTRUMENTS  
INCORPORATED

POST OFFICE BOX 225012 • DALLAS, TEXAS 75265

1080

**FUTURE PRODUCTS  
TO BE ANNOUNCED**

**TYPE SN75187  
QUADRUPLE LINE DRIVER**

OCTOBER 1980

- Meets EIA Standard RS-423A
- Operates From  $\pm 5$ -V Supplies
- Minimum Unloaded Output Voltage Of  $\pm 4$  V
- High-Impedance Output over  $\pm 6$ -V Common-Mode Range with Power Off (No external diode required)
- Low Power Dissipation . . . 60 mW Max per Channel
- Positive- and Negative-Current Limiting for Slew Rate Control

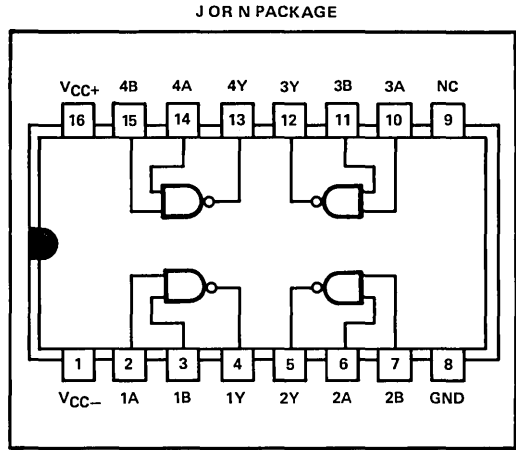

description

The SN75187 is a single-ended line driver designed to meet the requirements of EIA Standard RS-423A. The unloaded output voltage is at least 4 volts and  $-4$  volts for high and low levels, respectively, over the recommended ranges of supply voltage ( $\pm 4.5$  volts to  $\pm 5.5$  volts) and temperature ( $0^{\circ}\text{C}$  to  $70^{\circ}\text{C}$ ). The fully loaded output voltages are greater than  $\pm 3.6$  volts for the same conditions. The outputs maintain the high-impedance state when both power supplies are off over the common-mode input voltage range of  $-6$  volts to 6 volts. Limiting is provided for both positive and negative currents to limit slew rates.

5

PRODUCT PREVIEW

This document contains information on a product under development. Texas Instruments reserves the right to change or discontinue this product without notice.

**TEXAS INSTRUMENTS**  
INCORPORATED

POST OFFICE BOX 225012 • DALLAS, TEXAS 75265



# INTERFACE CIRCUITS

# TYPE SN75188 QUADRUPLE LINE DRIVER

BULLETIN NO. DL-S 11874, SEPTEMBER 1973—REVISED JANUARY 1977

- Meets Specifications of EIA RS-232C
- Designed to be Interchangeable with Motorola MC1488
- Current-Limited Output . . . 10 mA Typical
- Power-Off Output Impedance . . . 300  $\Omega$  Min
- Slew Rate Control by Load Capacitor
- Flexible Supply Voltage Range
- Input Compatible with Most TTL and DTL Circuits

### description

The SN75188 is a monolithic quadruple line driver designed to interface data terminal equipment with data communications equipment in conformance with the specifications of EIA Standard RS-232C with a diode in series with each supply-voltage terminal as shown under typical applications. The device is characterized for operation from 0°C to 75°C.

### schematic (each driver)

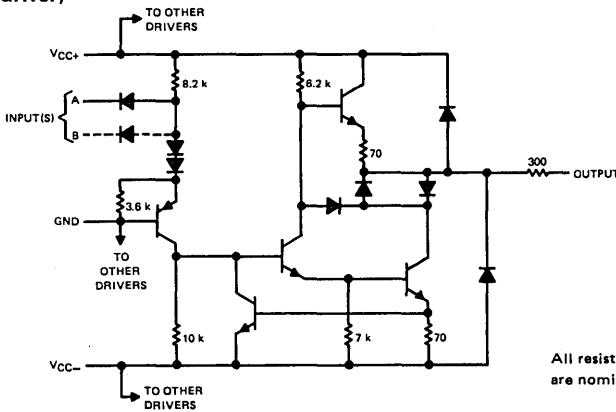

All resistor values shown are nominal and in ohms.

### absolute maximum ratings over operating free-air temperature range (unless otherwise noted)

Supply voltage $V_{CC+}$ at (or below) 25°C free-air temperature (see Notes 1 and 2)	15 V
Supply voltage $V_{CC-}$ at (or below) 25°C free-air temperature (see Notes 1 and 2)	-15 V
Input voltage range	-15 V to 7 V
Output voltage range	-15 V to 15 V
Continuous total dissipation at (or below) 25°C free-air temperature (see Note 2)	1 W
Operating free-air temperature range	0°C to 75°C
Storage temperature range	-65°C to 175°C
Lead temperature 1/16 inch from case for 60 seconds: J package	300°C
Lead temperature 1/16 inch from case for 10 seconds: N package	260°C

- NOTES: 1. All voltage values are with respect to the network ground terminal.  
 2. For operation above 25°C free-air temperature, refer to the Maximum Supply Voltage Curve, Figure 6, and the Dissipation Derating Curves in the Thermal Information section, which starts on page 2-1. In the J package, SN75188 chips are glass-mounted.

J OR N  
DUAL-IN-LINE PACKAGE  
(TOP VIEW)

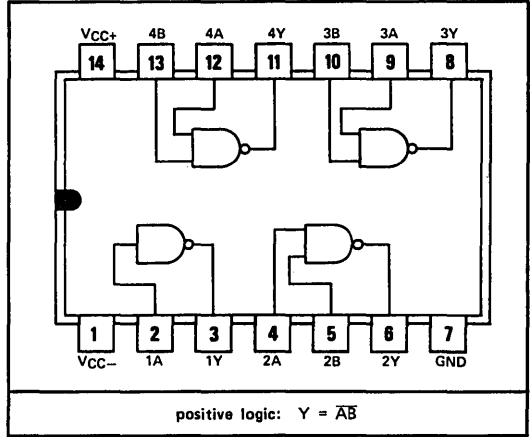

FUNCTION TABLE

A	B	Y
H	H	L
L	X	H
X	L	H

H = high level, L = low level,  
X = irrelevant

# TYPE SN75188

## QUADRUPLE LINE DRIVER

REVISED JANUARY 1977

electrical characteristics over operating free-air temperature range,  $V_{CC+} = 9\text{ V}$ ,  $V_{CC-} = -9\text{ V}$   
(unless otherwise noted)

PARAMETER		TEST CONDITIONS		MIN	TYP <sup>†</sup>	MAX	UNIT	
				(SEE NOTE 4)				
$V_{IH}$	High-level input voltage			1.9			V	
$V_{IL}$	Low-level input voltage					0.8	V	
$V_{OH}$	High-level output voltage	$V_{IL} = 0.8\text{ V}$ , $R_L = 3\text{ k}\Omega$	$V_{CC+} = 9\text{ V}$ , $V_{CC-} = -9\text{ V}$	6	7		V	
			$V_{CC+} = 13.2\text{ V}$ , $V_{CC-} = -13.2\text{ V}$	9	10.5			
$V_{OL}$	Low-level output voltage	$V_{IH} = 1.9\text{ V}$ , $R_L = 3\text{ k}\Omega$	$V_{CC+} = 9\text{ V}$ , $V_{CC-} = -9\text{ V}$		-7	-6	V	
			$V_{CC+} = 13.2\text{ V}$ , $V_{CC-} = -13.2\text{ V}$		-10.5	-9		
$I_{IH}$	High-level input current	$V_I = 5\text{ V}$				10	$\mu\text{A}$	
$I_{IL}$	Low-level input current	$V_I = 0$				-1	-1.6	$\text{mA}$
$I_{OS(H)}$	Short-circuit output current at high level $\blacklozenge$	$V_I = 0.8\text{ V}$ , $V_O = 0$		-6	-10	-12	$\text{mA}$	
$I_{OS(L)}$	Short-circuit output current at low level $\blacklozenge$	$V_I = 1.9\text{ V}$ , $V_O = 0$		6	10	12	$\text{mA}$	
$r_o$	Output resistance, power off	$V_{CC+} = 0$ , $V_{CC-} = 0$ , $V_O = -2\text{ V to } 2\text{ V}$		300			$\Omega$	
$I_{CC+}$	Supply current from $V_{CC+}$	$V_{CC+} = 9\text{ V}$ , No load	All inputs at 1.9 V	15	20		$\text{mA}$	
			All inputs at 0.8 V	4.5	6			
		$V_{CC+} = 12\text{ V}$ , No load	All inputs at 1.9 V	19	25			
			All inputs at 0.8 V	5.5	7			
$I_{CC-}$	Supply current from $V_{CC-}$	$V_{CC-} = -9\text{ V}$ , No load	All inputs at 1.9 V	-13	-17		$\text{mA}$	
			All inputs at 0.8 V		-0.015			
		$V_{CC-} = -12\text{ V}$ , No load	All inputs at 1.9 V	-18	-23			
			All inputs at 0.8 V		-0.015			
$P_D$	Total power dissipation	$V_{CC+} = 9\text{ V}$ , No load	$V_{CC-} = -9\text{ V}$			333	$\text{mW}$	
			$V_{CC-} = -12\text{ V}$			576		
		$V_{CC+} = 12\text{ V}$ , No load	$V_{CC-} = -9\text{ V}$					
			$V_{CC-} = -12\text{ V}$					

<sup>†</sup>All typical values are at  $T_A = 25^\circ\text{C}$ .

$\blacklozenge$ Not more than one output should be shorted at a time.

NOTE 4: The algebraic convention, where the less positive (more negative) limit is designated as minimum, is used in this data sheet for logic voltage levels only, e.g., if  $-6\text{ V}$  is a maximum, the typical value is a more negative voltage.

switching characteristics,  $V_{CC+} = 9\text{ V}$ ,  $V_{CC-} = -9\text{ V}$ ,  $T_A = 25^\circ\text{C}$

PARAMETER	TEST CONDITIONS	MIN	TYP	MAX	UNIT
$t_{PLH}$	Propagation delay time, low-to-high-level output		220	350	ns
$t_{PHL}$	Propagation delay time, high-to-low-level output	$R_L = 3\text{ k}\Omega$ , $C_L = 15\text{ pF}$	100	175	ns
$t_{TLH}$	Transition time, low-to-high-level output <sup>‡</sup>		55	100	ns
$t_{THL}$	Transition time, high-to-low-level output <sup>‡</sup>		45	75	ns
$t_{TLH}$	Transition time, low-to-high-level output <sup>§</sup>	$R_L = 3\text{ k}\Omega\text{ to } 7\text{ k}\Omega$ , $C_L = 2500\text{ pF}$	2.5		$\mu\text{s}$
$t_{THL}$	Transition time, high-to-low-level output <sup>§</sup>		3.0		$\mu\text{s}$

<sup>‡</sup>Measured between 10% and 90% points of output waveform.

<sup>§</sup>Measured between +3 V and -3 V points on the output waveform (EIA RS-232C conditions)

# TYPE SN75188 QUADRUPLE LINE DRIVER

## PARAMETER MEASUREMENT INFORMATION

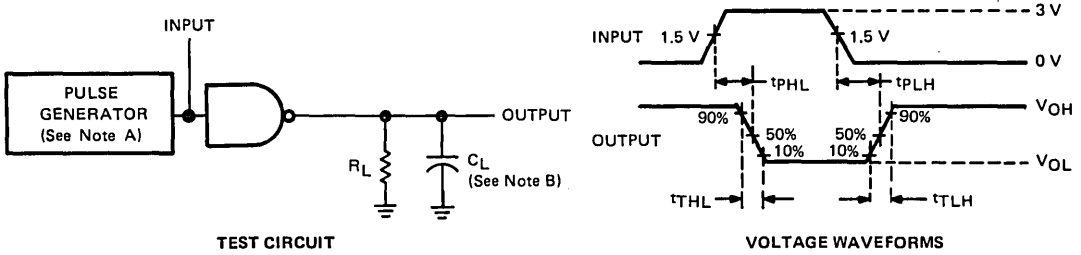

NOTE: A. The pulse generator has the following characteristics:  $t_w = 0.5 \mu s$ ,  $PRR = 1 \text{ MHz}$ ,  $Z_o = 50 \Omega$ .  
B.  $C_L$  includes probe and jig capacitance.

FIGURE 1—PROPAGATION AND TRANSITION TIMES

## TYPICAL CHARACTERISTICS

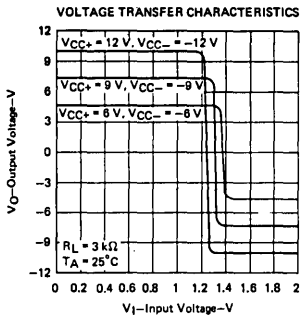

FIGURE 2

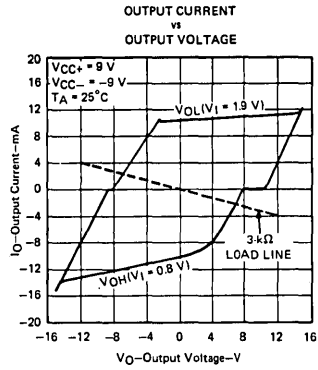

FIGURE 3

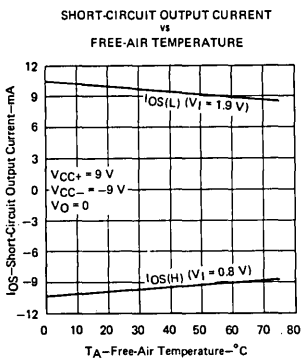

FIGURE 4

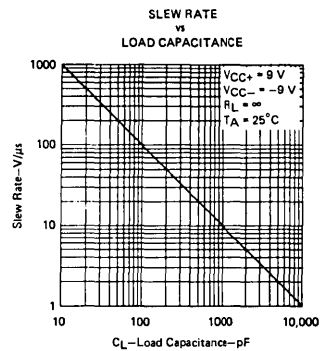
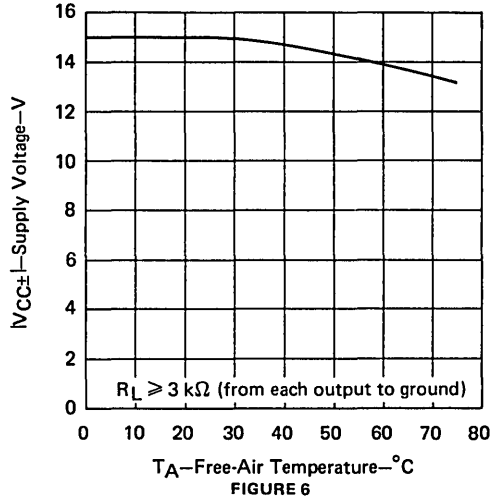

FIGURE 5

5

# TYPE SN75188 QUADRUPLE LINE DRIVER

## THERMAL INFORMATION MAXIMUM SUPPLY VOLTAGE vs FREE-AIR TEMPERATURE



## TYPICAL APPLICATION DATA

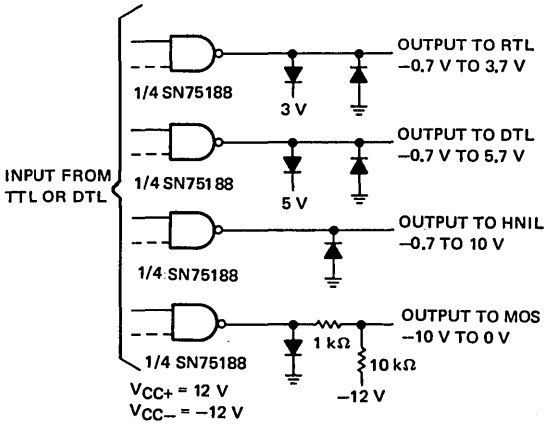

FIGURE 7—LOGIC TRANSLATOR APPLICATIONS

Diodes placed in series with the  $V_{CC+}$  and  $V_{CC-}$  leads will protect the SN75188 in the fault condition where the device outputs are shorted to  $\pm 15 \text{ V}$  and the power supplies are at low voltage and provide low-impedance paths to ground.

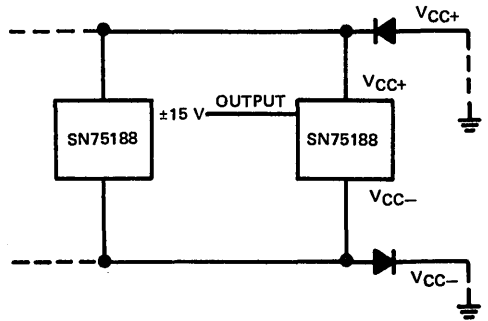

FIGURE 8—POWER SUPPLY PROTECTION TO MEET POWER-OFF FAULT CONDITIONS OF EIA STANDARD RS-232C



# INTERFACE CIRCUITS

# TYPES SN75189, SN75189A QUADRUPLE LINE RECEIVERS

BULLETIN NO. DL-S 12035, SEPTEMBER 1973 — REVISED SEPTEMBER 1980

- Input Resistance . . . 3 k $\Omega$  to 7 k $\Omega$
- Input Signal Range . . .  $\pm 30$  V
- Fully Interchangeable with Motorola MC1489, MC1489A
- Operates From Single 5-V Supply
- Built-in Input Hysteresis (Double Thresholds)
- Response Control Provides:
  - Input Threshold Shifting
  - Input Noise Filtering
- Satisfies Requirements of EIA RS-232-C

schematic (each receiver)

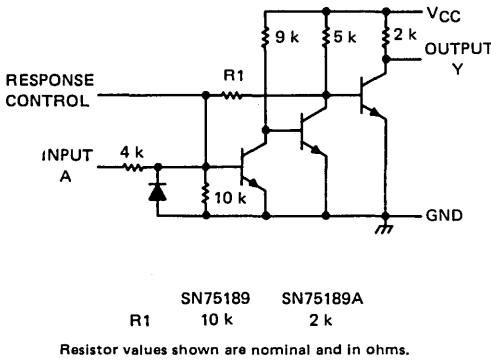

J OR N  
DUAL-IN-LINE PACKAGE (TOP VIEW)

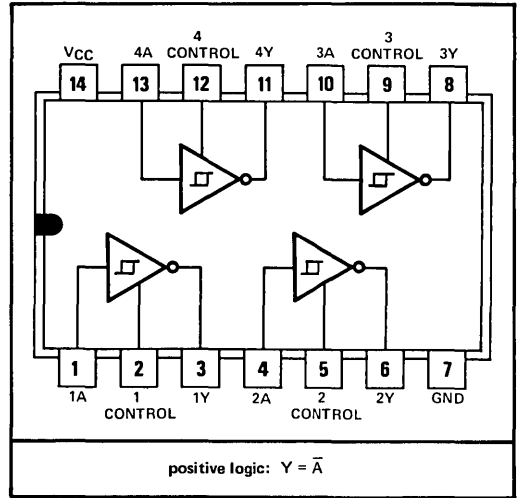

## description

The SN75189 and SN75189A are monolithic quadruple line receivers designed to satisfy the requirements of the standard interface between data terminal equipment and data communication equipment as defined by EIA Standard RS-232C. A separate response control terminal is provided for each receiver. A resistor or a resistor and bias voltage source can be connected between this terminal and ground to shift the input threshold voltage levels. An external capacitor can be connected between this terminal and ground to provide input noise filtering.

## absolute maximum ratings at 25°C free-air temperature (unless otherwise noted)

Supply voltage, $V_{CC}$ (see Note 1)	10 V
Input voltage	$\pm 30$ V
Output current	20 mA
Continuous total dissipation at (or below) 25°C free-air temperature (see Note 2)	1 W
Operating free-air temperature range	0°C to 75°C
Storage temperature range	-65°C to 175°C
Lead temperature 1/16 inch from case for 60 seconds: J package	300°C
Lead temperature 1/16 inch from case for 10 seconds: N package	260°C

NOTES: 1. Voltage values are with respect to the network ground terminal.

2. For operation above 25°C free-air temperature, refer to Dissipation Derating Curves in the Thermal Information section, which starts on page 2-1. In the J package, SN75189 and SN75189A chips are glass-mounted.

Copyright © 1980 by Texas Instruments Incorporated

# TYPES SN75189, SN75189A QUADRUPLE LINE RECEIVERS

electrical characteristics over operating free-air temperature range,  $V_{CC} = 5V \pm 1\%$ , (unless otherwise noted)

PARAMETER	TEST FIGURE	TEST CONDITIONS†	SN75189			SN75189A			UNIT
			MIN	TYP‡	MAX	MIN	TYP‡	MAX	
$V_{T+}$ Positive-going threshold voltage	1	$T_A = 25^\circ\text{C}$	1	1.5	1.75	1.9	2.25	V	
			0.9	1.6	1.55	2.25			
$V_{T-}$ Negative-going threshold voltage	1	$T_A = 25^\circ\text{C}$	0.75	1.25	0.75	0.97	1.25	V	
			0.65	1.25	0.65	1.25			
$V_{OH}$ High-level output voltage	1	$V_I = 0.75\text{ V}$ , $I_{OH} = -0.5\text{ mA}$	2.6	4	5	2.6	4	5	V
		Input open, $I_{OH} = -0.5\text{ mA}$	2.6	4	5	2.6	4	5	
$V_{OL}$ Low-level output voltage	1	$V_I = 3\text{ V}$ , $I_{OL} = 10\text{ mA}$	0.2	0.45	0.2	0.45	V		
$I_{IH}$ High-level input current	2	$V_I = 25\text{ V}$	3.6	8.3	3.6	8.3	mA		
		$V_I = 3\text{ V}$	0.43	0.43	0.43	0.43			
$I_{IL}$ Low-level input current	2	$V_I = -25\text{ V}$	-3.6	-8.3	-3.6	-8.3	mA		
		$V_I = -3\text{ V}$	-0.43	-0.43	-0.43	-0.43			
$I_{OS}$ Short-circuit output current	3		-3	-3	-3	mA			
$I_{CC}$ Supply current	2	$V_I = 5\text{ V}$ , Outputs open	20	26	20	26	mA		

† All characteristics are measured with the response control terminal open.

‡ All typical values are at  $V_{CC} = 5\text{ V}$ ,  $T_A = 25^\circ\text{C}$ .

switching characteristics,  $V_{CC} = 5\text{ V}$ ,  $T_A = 25^\circ\text{C}$

PARAMETER	TEST FIGURE	TEST CONDITIONS	MIN	TYP	MAX	UNIT
$t_{PLH}$ Propagation delay time, low-to-high-level output	4	$C_L = 15\text{ pF}$ , $R_L = 3.9\text{ k}\Omega$	25	85		ns
$t_{PHL}$ Propagation delay time, high-to-low-level output		$C_L = 15\text{ pF}$ , $R_L = 390\ \Omega$	25	50		
$t_{TLH}$ Transition time, low-to-high-level output		$C_L = 15\text{ pF}$ , $R_L = 3.9\text{ k}\Omega$	120	175		ns
$t_{THL}$ Transition time, high-to-low-level output		$C_L = 15\text{ pF}$ , $R_L = 390\ \Omega$	10	20		

## PARAMETER MEASUREMENT INFORMATION§

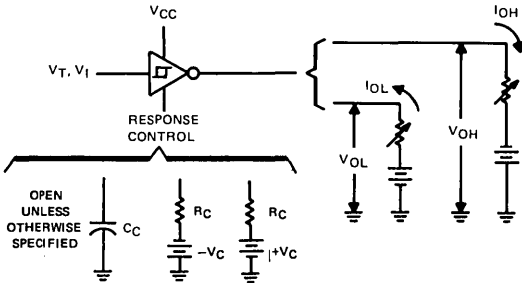

FIGURE 1— $V_{T+}$ ,  $V_{T-}$ ,  $V_{OH}$ ,  $V_{OL}$

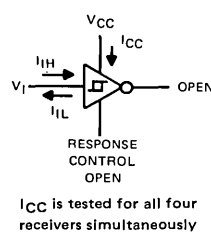

FIGURE 2— $I_{IH}$ ,  $I_{IL}$ ,  $I_{CC}$

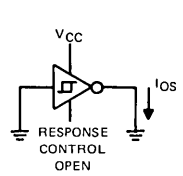
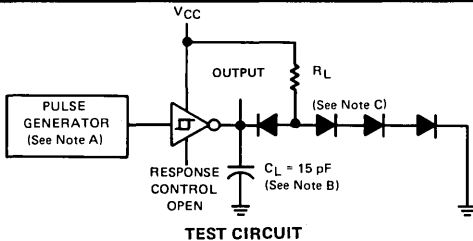
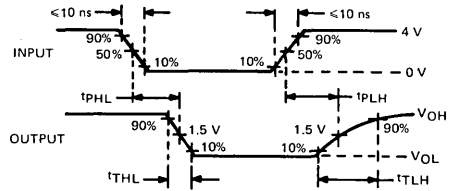

FIGURE 3— $I_{OS}$



TEST CIRCUIT



VOLTAGE WAVEFORMS

NOTES: A. The pulse generator has the following characteristics:  $Z_{out} \approx 50\ \Omega$ ,  $t_w = 500\text{ ns}$ .  
B.  $C_L$  includes probe and jig capacitance. C. All diodes are 1N3064 or equivalent.

FIGURE 4—SWITCHING TIMES

§ Arrows indicate actual direction of current flow. Current into a terminal is a positive value.

# TYPES SN75189, SN75189A QUADRUPLE LINE RECEIVERS

## TYPICAL CHARACTERISTICS

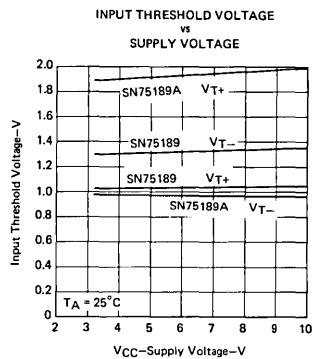
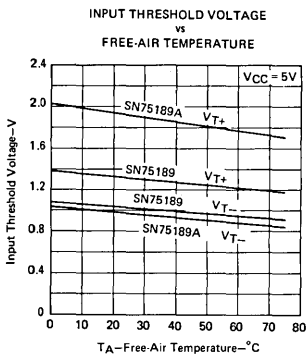
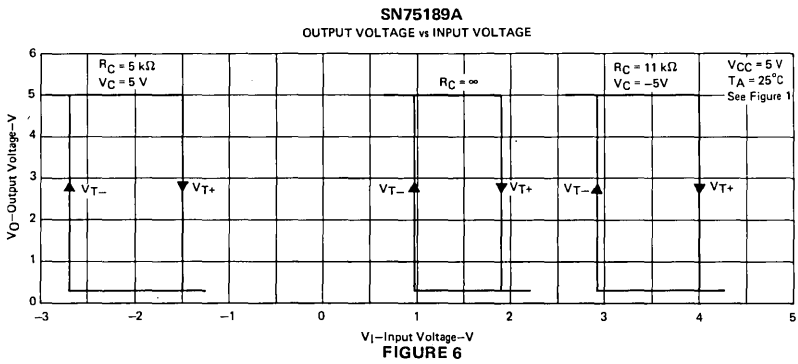
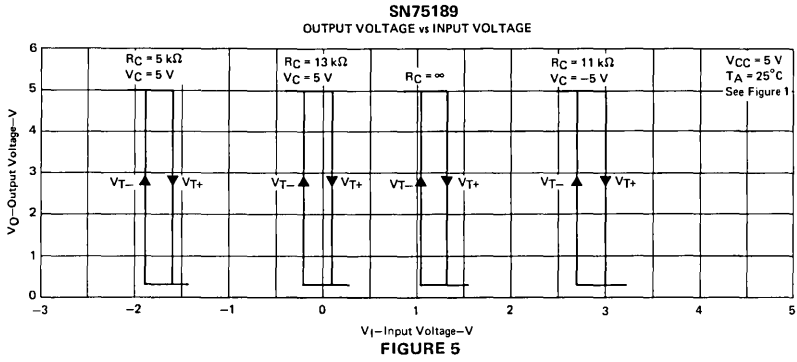

**TEXAS INSTRUMENTS**  
INCORPORATED

POST OFFICE BOX 225012 • DALLAS, TEXAS 75265

# TYPES SN75189, SN75189A QUADRUPLE LINE RECEIVERS

## TYPICAL CHARACTERISTICS

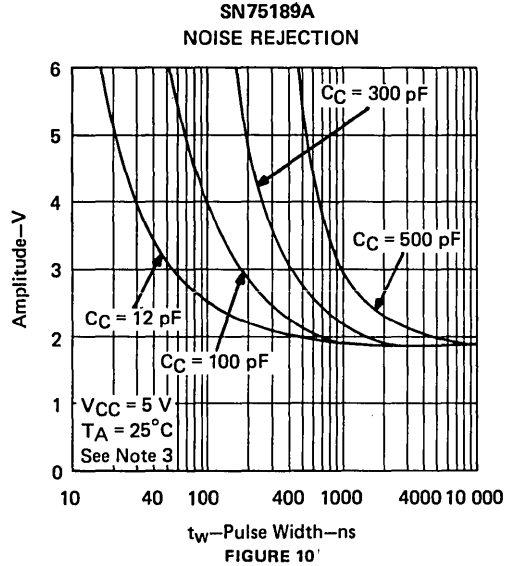
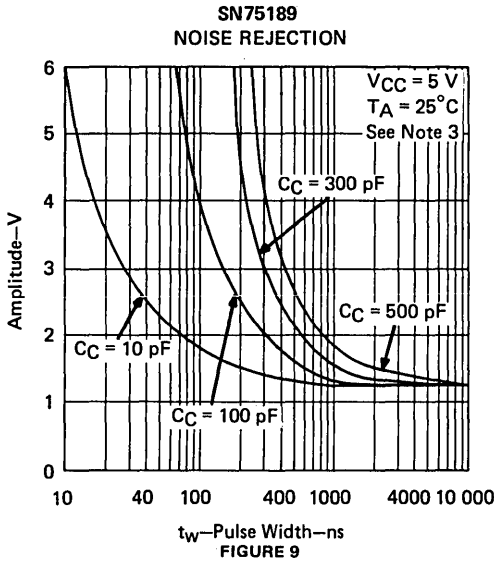

### INPUT CURRENT vs INPUT VOLTAGE

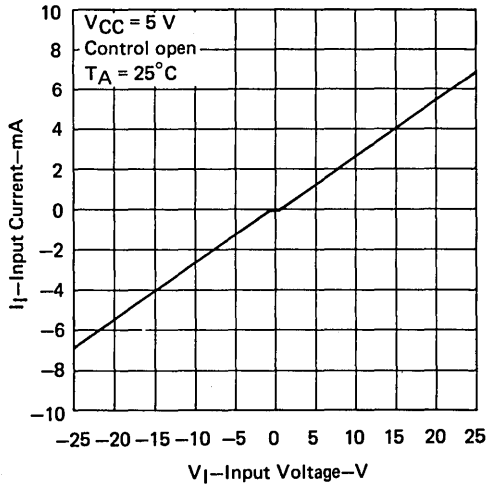

NOTE 3: This figure shows the maximum amplitude of a positive-going pulse that, starting from zero volts, will not cause a change of the output level.

# INTERFACE CIRCUITS

## TYPES SN75207, SN75207B, SN75208, SN75208B DUAL SENSE AMPLIFIERS FOR MOS MEMORIES OR DUAL HIGH-SENSITIVITY LINE RECEIVERS

BULLETIN NO. DL-S 11793, JULY 1973—REVISED JANUARY 1977

- Plug-in Replacement for SN75107A, SN75107B, SN75108A, SN75108B with Improved Characteristics
- $\pm 10$  mV Guaranteed Input Sensitivity
- TTL Compatible
- Standard Supply Voltages . . .  $\pm 5$  V
- Differential Input Common-Mode Voltage Range of  $\pm 3$  V
- Strobe Inputs for Channel Selection
- '207 and '207B Have Totem-Pole Outputs
- '208 and '208B Have Open-Collector Outputs
- "B" Versions Have Diode-Protected Input Stage for Power-Off Condition
- Sense Amplifier for MOS Memories
- Dual Comparator
- High-Sensitivity Line Receiver

J OR N  
DUAL-IN-LINE PACKAGE  
(TOP VIEW)

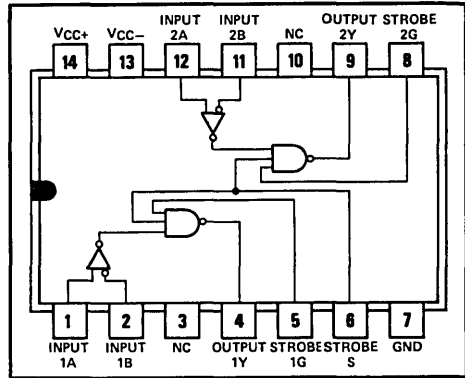

NC—No internal connection

5

### description

The SN75207, SN75207B, SN75208, and SN75208B are pin-for-pin replacements for the SN75107A, SN75107B, SN75108A, and SN75108B, respectively. The improved input sensitivity makes them more suitable for MOS memory sense amplifiers and can result in faster memory cycles. Improved sensitivity also makes them more useful in line receiver applications by allowing use of longer transmission line lengths. The '207 and '207B each features a TTL-compatible active-pull-up output. The '208 and '208B each features an open-collector output that permits wired-AND logic connections with similar output configurations. These devices are designed for operation from 0°C to 70°C and are available in the ceramic dual-in-line (J) package or in the plastic dual-in-line (N) package.

FUNCTION TABLE

DIFFERENTIAL INPUTS A-B	STROBES		OUTPUT Y
	G	S	
$V_{ID} \geq 10$ mV	X	X	H
$-10$ mV $< V_{ID} < 10$ mV	X	L	H
	L	X	H
	H	H	Indeterminate
$V_{ID} < -10$ mV	X	L	H
	L	X	H
	H	H	L

H = high level, L = low level, X = irrelevant

The essential difference between the unsuffixed and "B" versions can be seen in the schematics. Input-protection diodes are in series with the collectors of the differential-input transistors of the "B" versions. These diodes are useful in certain "party-line" systems that may have multiple VCC+ power supplies and may be operated with some of the VCC+ supplies turned off. In such a system, if a supply is turned off and allowed to go to ground, the equivalent input circuit connected to that supply would be as follows:

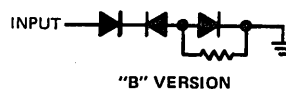

This would be a problem in specific systems that might possibly have the transmission lines biased to some potential greater than 1.4 volts.

# TYPES SN75207, SN75207B, SN75208, SN75208B DUAL SENSE AMPLIFIERS FOR MOS MEMORIES OR DUAL HIGH-SENSITIVITY LINE RECEIVERS

## design characteristics

The '207, '207B, '208, and '208B line receivers/sense amplifiers are TTL-compatible dual circuits intended for use in high-speed data-transmission systems or MOS memory systems. They are designed to detect low-level differential signals in the presence of common-mode noise and variations of temperature and supplies. Dc specifications reflect worst-case conditions of temperature, supply voltages, and input voltages.

The input common-mode voltage range is  $\pm 3$  volts. This is adequate for application in most systems. In systems with requirements for greater common-mode voltage range, input attenuators may be used to decrease the noise to an acceptable level at the receiver-input terminals.

The circuits feature individual strobe inputs for each channel and a strobe input common to both channels for logic versatility. The strobe inputs are tested to guarantee 400 millivolts of dc noise margin when interfaced with Series 54/74 TTL.

The circuits feature high input impedance and low input currents, which induce very little loading on the transmission line. This makes these devices especially useful in party-line systems. The excellent input sensitivity (3 millivolts typical) is particularly important when data is to be detected at the end of a long transmission line and the amplitude of the data has deteriorated due to cable losses. The circuits are designed to detect input signals of 10 millivolts (or greater) amplitude and convert the polarity of the signal into appropriate TTL-compatible output logic levels.

5

## schematic (each receiver)

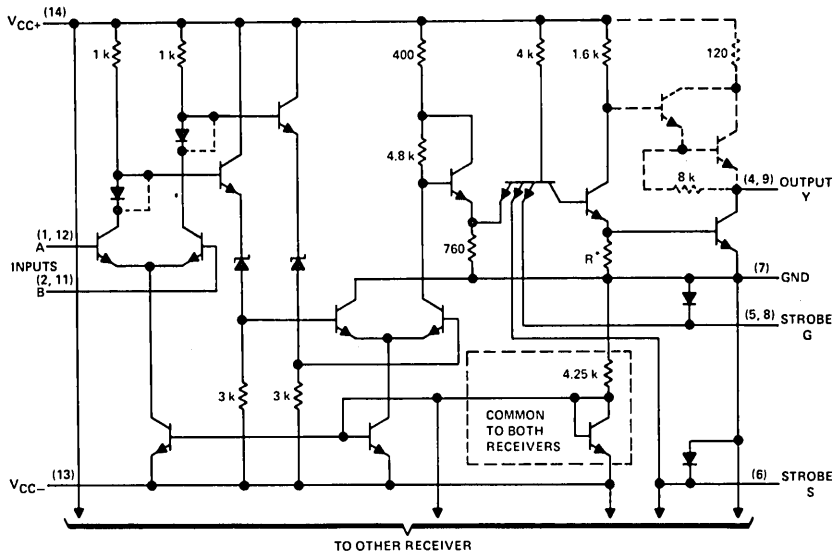

\* R = 1 k $\Omega$  for '207 and '207B, 750  $\Omega$  for '208 and '208B.

NOTES: A. Resistor values shown are nominal and in ohms.

B. Components shown with dashed lines in the output circuitry are applicable to the '207 and '207B only. Diodes in series with the collectors of the differential input transistors are short-circuited on '207 and '208.

# TYPES SN75207, SN75207B, SN75208, SN75208B DUAL SENSE AMPLIFIERS FOR MOS MEMORIES OR DUAL HIGH-SENSITIVITY LINE RECEIVERS

## absolute maximum ratings over operating free-air temperature range (unless otherwise noted)

Supply voltage $V_{CC+}$ (see Note 1)	7 V
Supply voltage $V_{CC-}$	-7 V
Differential input voltage (see Note 2)	$\pm 6$ V
Common-mode input voltage (see Note 3)	$\pm 5$ V
Strobe input voltage	5.5 V
Continuous total dissipation	600 mW
Operating free-air temperature range	$0^{\circ}\text{C}$ to $70^{\circ}\text{C}$
Storage temperature range	$-65^{\circ}\text{C}$ to $150^{\circ}\text{C}$

## recommended operating conditions (see note 4)

	MIN	NOM	MAX	UNIT
Supply voltage $V_{CC+}$	4.75	5	5.25	V
Supply voltage $V_{CC-}$	-4.75	-5	-5.25	V
Low-level output current, $I_{OL}$			-16	mA
Differential input voltage, $V_{ID}$ (see Note 5)	$-5^{\dagger}$		5	V
Common-mode input voltage, $V_{IC}$ (see Notes 5 and 6)	$-3^{\dagger}$		3	V
Input voltage range, any differential input to ground (see Note 5)	$-5^{\dagger}$		3	V
Operating free-air temperature, $T_A$	0		70	$^{\circ}\text{C}$

<sup>†</sup>The algebraic convention, where the less positive (more negative) limit is designated as minimum, is used in this data sheet for logic voltage levels only.

- NOTES:
- All voltage values, except differential voltages, are with respect to network ground terminal.
  - Differential voltage values are at the noninverting (A) terminal with respect to the inverting (B) terminal.
  - Common-mode input voltage is the average of the voltages at the A and B inputs.
  - When using only one channel of the line receiver, the strobe G of the unused channel should be grounded and at least one of the differential inputs of the unused receiver should be terminated at some voltage between -3 V and 3 V.
  - The recommended combinations of input voltages fall within the shaded area of the figure at the right.
  - The common-mode voltage may be as low as -4 V provided that the more positive of the two inputs is not more negative than -3 V.

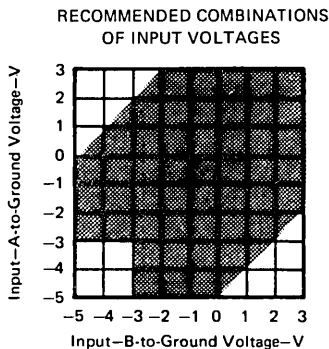

# TYPES SN75207, SN75207B, SN75208, SN75208B DUAL SENSE AMPLIFIERS FOR MOS MEMORIES OR DUAL HIGH-SENSITIVITY LINE RECEIVERS

## definition of input logic levels†

		MIN	MAX	UNIT
V <sub>IDH</sub>	High-level input voltage between differential inputs	0.01	5	V
V <sub>IDL</sub>	Low-level input voltage between differential inputs	-5	-0.01	V
V <sub>IH(S)</sub>	High-level input voltage at strobe inputs	2	5.5	V
V <sub>IL(S)</sub>	Low-level input voltage at strobe inputs	0	0.8	V

† The algebraic convention, where the more positive (less negative) limit is designated maximum, is used in this data sheet with logic input voltage levels only.

## electrical characteristics over recommended free-air temperature range (unless otherwise noted)

PARAMETER		TEST CONDITIONS‡		'207, '207B		'208, '208B		UNIT	
				MIN	TYP §	MAX	MIN		TYP §
I <sub>IH</sub>	High-level input current	A	V <sub>CC±</sub> = MAX	V <sub>ID</sub> = 5 V	30	75	30	75	μA
				V <sub>ID</sub> = -5 V	30	75	30	75	
I <sub>IL</sub>	Low-level input current	A	V <sub>CC±</sub> = MAX	V <sub>ID</sub> = -5 V		-10		-10	μA
				V <sub>ID</sub> = 5 V		-10		-10	
I <sub>IH</sub>	High-level input current into 1G or 2G	A	V <sub>CC±</sub> = MAX, V <sub>IH(S)</sub> = 2.4 V		40		40	μA	
			V <sub>CC±</sub> = MAX, V <sub>IH(S)</sub> = MAX V <sub>CC+</sub>		1		1	mA	
I <sub>IL</sub>	Low-level input current into 1G or 2G	A	V <sub>CC±</sub> = MAX, V <sub>IL(S)</sub> = 0.4 V		-1.6		-1.6	mA	
			V <sub>CC±</sub> = MAX, V <sub>IL(S)</sub> = 0.4 V		-1.6		-1.6	mA	
I <sub>IH</sub>	High-level input current into S	A	V <sub>CC±</sub> = MAX, V <sub>IH(S)</sub> = 2.4 V		80		80	μA	
			V <sub>CC±</sub> = MAX, V <sub>IH(S)</sub> = MAX V <sub>CC+</sub>		2		2	mA	
I <sub>IL</sub>	Low-level input current into S	A	V <sub>CC±</sub> = MAX, V <sub>IL(S)</sub> = 0.4 V		-3.2		-3.2	mA	
			V <sub>CC±</sub> = MAX, V <sub>IL(S)</sub> = 0.4 V		-3.2		-3.2	mA	
V <sub>OH</sub>	High-level output voltage		V <sub>CC±</sub> = MIN, V <sub>IL(S)</sub> = 0.8 V, V <sub>IDH</sub> = 10 mV, I <sub>OH</sub> = -400 μA, V <sub>IC</sub> = -3 V to 3 V	2.4				V	
V <sub>OL</sub>	Low-level output voltage		V <sub>CC±</sub> = MIN, V <sub>IH(S)</sub> = 2 V, V <sub>IDL</sub> = -10 mV, I <sub>OL</sub> = 16 mA, V <sub>IC</sub> = -3 V to 3 V		0.4		0.4	V	
I <sub>OH</sub>	High-level output current		V <sub>CC±</sub> = MIN, V <sub>OH</sub> = MAX V <sub>CC+</sub>				250	μA	
I <sub>OS</sub>	Short-circuit output current¶		V <sub>CC±</sub> = MAX	-18	-70			mA	
I <sub>CCH+</sub>	Supply current from V <sub>CC+</sub> , outputs high		V <sub>CC±</sub> = MAX, T <sub>A</sub> = 25°C	18	30	18	30	mA	
I <sub>CCH-</sub>	Supply current from V <sub>CC-</sub> , outputs high		V <sub>CC±</sub> = MAX, T <sub>A</sub> = 25°C	-8.4	-15	-8.4	-15	mA	

‡ For conditions shown as MIN or MAX, use the appropriate value specified under recommended operating conditions.

§ All typical values are at V<sub>CC+</sub> = 5 V, V<sub>CC-</sub> = -5 V, T<sub>A</sub> = 25°C.

¶ Not more than one output should be shorted at a time.

## switching characteristics, V<sub>CC+</sub> = 5 V, V<sub>CC-</sub> = -5 V, T<sub>A</sub> = 25°C

PARAMETER		TEST CONDITIONS		'207, '207B		'208, '208B		UNIT
				MIN	TYP	MAX	MIN	
t <sub>PLH(D)</sub>	Propagation delay time, low-to-high-level output, from differential inputs A and B				35		35	ns
t <sub>PHL(D)</sub>	Propagation delay time, high-to-low-level output, from differential inputs A and B				20		20	ns
t <sub>PLH(S)</sub>	Propagation delay time, low-to-high-level output, from strobe input G or S				17		17	ns
t <sub>PHL(S)</sub>	Propagation delay time, high-to-low-level output, from strobe input G or S				17		17	ns



# TYPES SN75207, SN75207B, SN75208, SN75208B DUAL SENSE AMPLIFIERS FOR MOS MEMORIES OR DUAL HIGH-SENSITIVITY LINE RECEIVERS

## PARAMETER MEASUREMENT INFORMATION

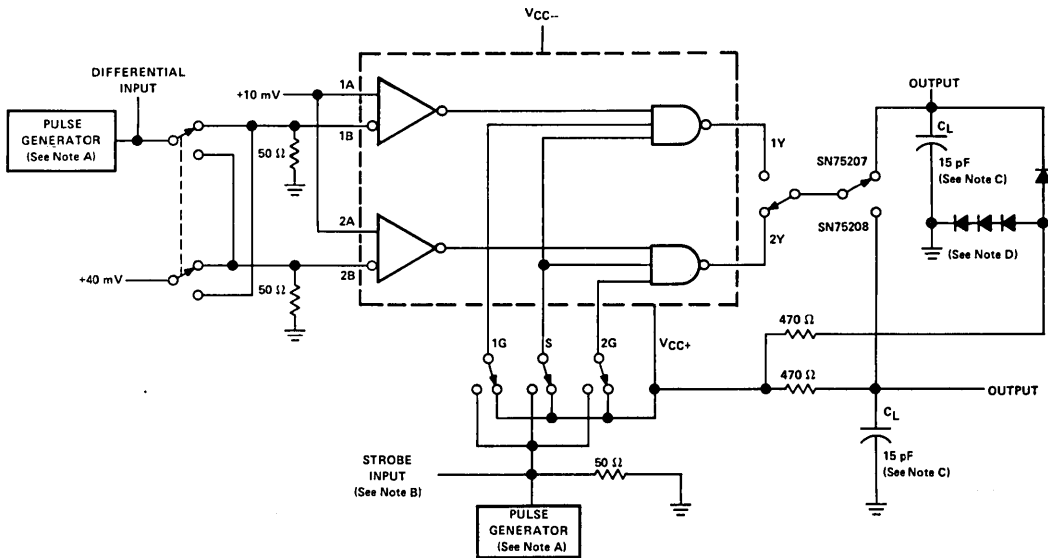

## TEST CIRCUIT

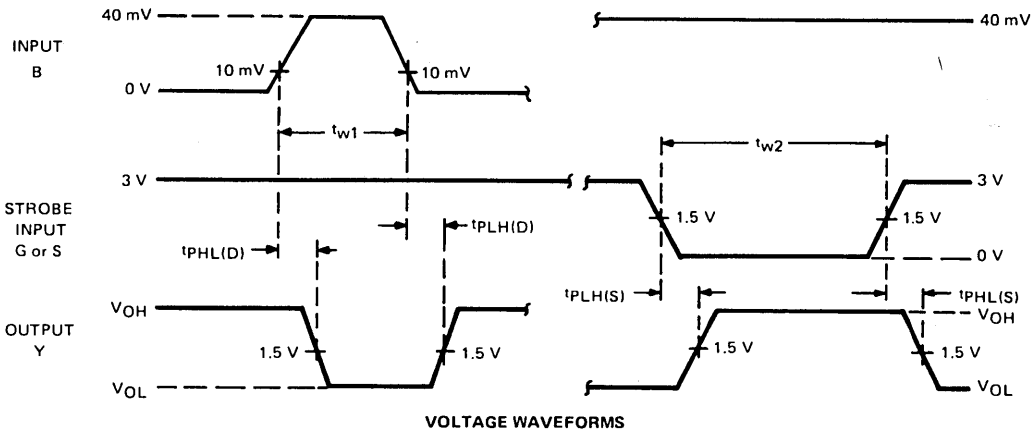

## VOLTAGE WAVEFORMS

- NOTES: A. The pulse generators have the following characteristics:  $Z_{out} = 50 \Omega$ ,  $t_r \leq 5 \text{ ns}$ ,  $t_f \leq 5 \text{ ns}$ ,  $t_{w1} = 500 \text{ ns}$  with PRR = 1 MHz,  $t_{w2} = 1 \mu\text{s}$  with PRR = 500 kHz.  
B. Strobe input pulse is applied to Strobe 1G when inputs 1A-1B are being tested, to Strobe S when inputs 1A-1B or 2A-2B are being tested, and to Strobe 2G when inputs 2A-2B are being tested.  
C.  $C_L$  includes probe and jig capacitance.  
D. All diodes are 1N916.

FIGURE 1—PROPAGATION DELAY TIMES

# TYPES SN75207, SN75207B, SN75208, SN75208B DUAL SENSE AMPLIFIERS FOR MOS MEMORIES OR DUAL HIGH-SENSITIVITY LINE RECEIVERS

## TYPICAL APPLICATION DATA

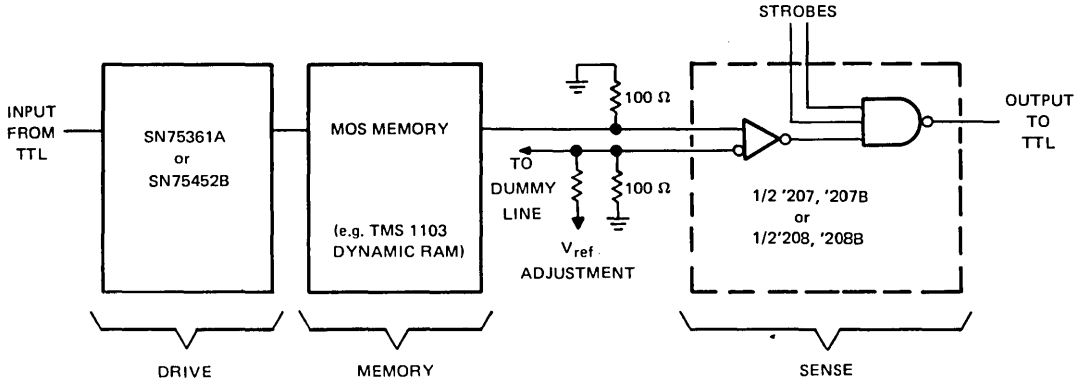
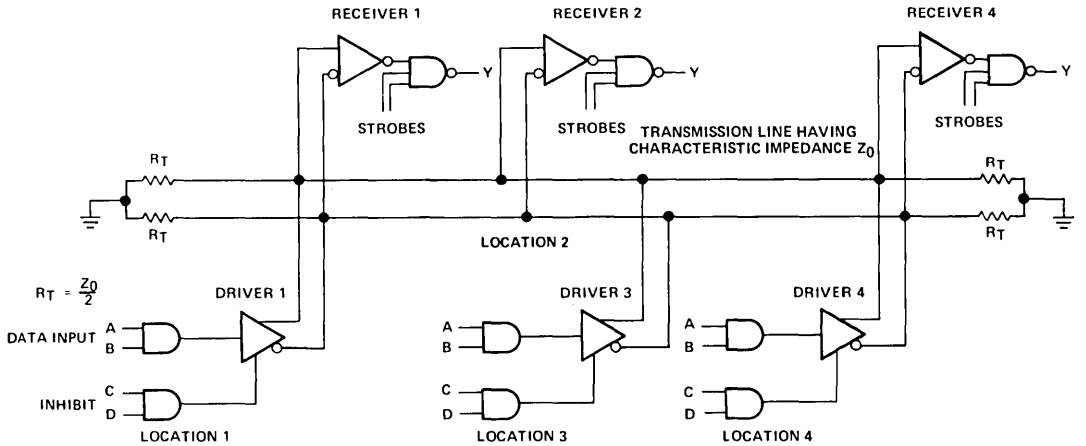

FIGURE 2—MOS MEMORY SENSE AMPLIFIER

5



Receivers are '207, '207B, '208, or '208B; drivers are SN55109A, SN75109A, SN55110A, SN75110A, or SN75112.

FIGURE 3—DATA-BUS OR PARTY-LINE SYSTEM

**PRECAUTIONS:** When only one receiver in a package is being used, at least one of the differential inputs of the unused receiver should be terminated at some voltage between  $-3$  volts and  $+3$  volts, preferably at ground. Failure to do so will cause improper operation of the unit being used because of common bias circuitry for the current sources of the two receivers. Strobe G of the unused channel should be grounded.

# TYPE $\mu$ A9636AC

## DUAL LINE DRIVERS WITH ADJUSTABLE SLEW RATE

BULLETIN NO. DL-S 12774, OCTOBER 1980

- Meets EIA Standards RS-423, RS-232C, and Federal Standard 1030
- Slew Rate Control
- Output Short-Circuit-Current Limiting
- Wide Supply Voltage Range
- 8-Pin Dual-In-Line Package
- Designed to be Interchangeable With Fairchild 9636A

JG OR P DUAL-IN-LINE PACKAGE  
(TOP VIEW)

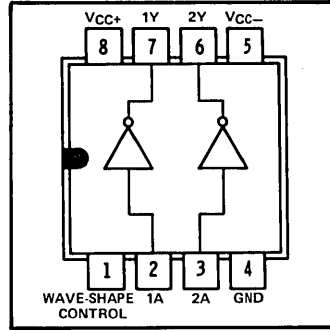

### description

The  $\mu$ A9636AC is a dual single-ended line driver designed to meet EIA Standards RS-423, RS-232C, and Federal Standard 1030. The slew rates of both amplifiers are controlled by a single external resistor,  $R_{WS}$ , connected between the wave-shape-control terminal and ground. Output current limiting is provided. Inputs are compatible with TTL and CMOS and are diode-protected against negative transients. This device operates from  $\pm 12$  volts and is supplied in an 8-pin dual-in-line package.

The  $\mu$ A9636AC is characterized for operation from  $0^{\circ}\text{C}$  to  $70^{\circ}\text{C}$ .

5

### schematics of inputs and outputs

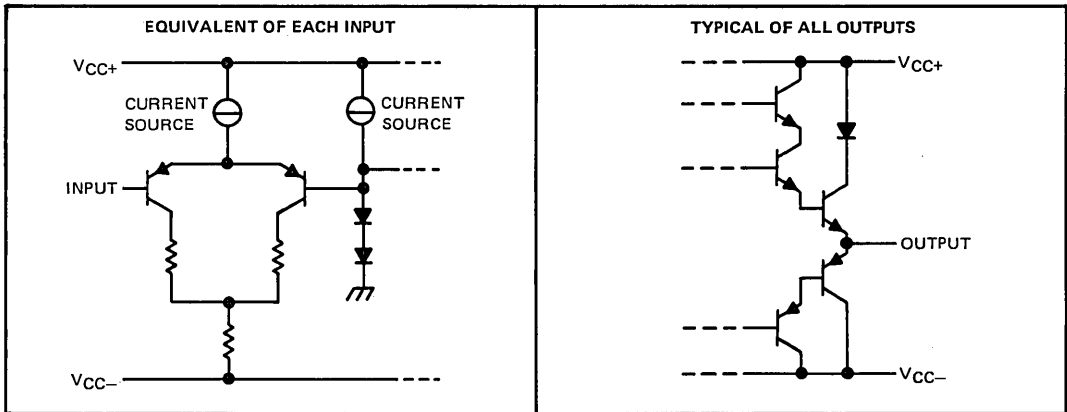

Copyright © 1980 by Texas Instruments Incorporated

**TEXAS INSTRUMENTS**  
INCORPORATED

POST OFFICE BOX 225012 • DALLAS, TEXAS 75265

5-251

# TYPE $\mu$ A9636AC

## DUAL LINE DRIVERS WITH ADJUSTABLE SLEW RATE

### absolute maximum ratings over operating free-air temperature range (unless otherwise noted)

Positive supply voltage range, $V_{CC+}$ (see Note 1)	$V_{CC-}$ to 15 V
Negative supply voltage range, $V_{CC-}$	0.5 V to -15 V
Output voltage	$\pm 15$ V
Output current	$\pm 150$ mA
Continuous total dissipation at (or below) 25°C free-air temperature (see Note 2): JG package	825 mW
P package	1000 mW
Operating free-air temperature range	0°C to 70°C
Storage temperature range	-65°C to 150°C
Lead temperature 1/16 inch (1,6 mm) from case for 60 seconds: JG package	300°C
Lead temperature 1/16 inch (1,6 mm) from case for 10 seconds: P package	260°C

- NOTES: 1. All voltage values are with respect to the network ground terminal.  
 2. For operation above 25°C free-air temperature, derate at the rate of 6.6 mW/°C for the JG package and 8.0 mW/°C for the P package.

### recommended operating conditions

	MIN	NOM	MAX	UNIT
Positive supply voltage, $V_{CC+}$	10.8	12	13.2	V
Negative supply voltage, $V_{CC-}$	-10.8	-12	-13.2	V
Operating free-air temperature, $T_A$	0		70	°C
Wave-shaping resistor, $R_{WS}$	10		1000	k $\Omega$

### electrical characteristics over recommended range of free-air temperature, supply voltage, and wave-shaping resistance (unless otherwise noted)

PARAMETER	TEST CONDITIONS	MIN	TYP <sup>†</sup>	MAX	UNIT	
$V_{IH}$	High-level input voltage	2			V	
$V_{IL}$	Low-level input voltage	0.8			V	
$V_{IK}$	Input clamp voltage	$I_I = -15$ mA		-1.1 -1.5	V	
$V_{OH}$	High-level output voltage	$V_I = 0.8$ V	$R_L = \infty$	5 5.6 6	V	
			$R_L = 3$ k $\Omega$ to ground	5 5.6 6		
			$R_L = 450$ $\Omega$ to ground	4 5.4 6		
$V_{OL}$	Low-level output voltage	$V_I = 2$ V	$R_L = \infty$	-6 -5.7 -5	V	
			$R_L = 3$ k $\Omega$ to ground	-6 -5.6 -5		
			$R_L = 450$ $\Omega$ to ground	-6 -5.4 -4		
$I_{IH}$	High-level input current	$V_I = 2.4$ V	10		$\mu$ A	
		$V_I = 5.5$ V	100			
$I_{IL}$	Low-level input current	$V_I = 0.4$ V		-20 -80	$\mu$ A	
$I_O$	Output current (power off)	$V_{CC\pm} = 0$ , $V_O = \pm 6$ V			$\pm 100$	$\mu$ A
$I_{OS}$	Short-circuit output current <sup>‡</sup>	$V_I = 2$ V	15 25 150		mA	
		$V_I = 0$ V	-15 -40 -150			
$r_o$	output resistance	$R_L = 450$ $\Omega$		25 50	$\Omega$	
$I_{CC+}$	Positive supply current	$V_{CC} = \pm 12$ V, $R_{WS} = 100$ k $\Omega$ , $V_I = 0$ V, Output open	13 18	mA		
$I_{CC-}$	Negative supply current	$V_{CC} = \pm 12$ V, $R_{WS} = 100$ k $\Omega$ , $V_I = 0$ V, Output open	-13 -18	mA		

<sup>†</sup>All typical values are at  $V_{CC} \pm 12$  V,  $T_A = 25^\circ$  C.

<sup>‡</sup>Not more than one output should be shorted to ground at a time, and duration of the short-circuit should not exceed one-second.

NOTE 3: The algebraic convention, where the less-positive (more-negative) limit is designated as minimum, is used in this data sheet for logic voltage levels, e.g., when -5 V is the maximum, the minimum is a more-negative voltage.

# TYPE $\mu$ A9636AC

## DUAL LINE DRIVERS WITH ADJUSTABLE SLEW RATE

switching characteristics,  $V_{CC\pm} = 12\text{ V}$ ,  $T_A = 25^\circ\text{C}$ , see figure 1

PARAMETER	TEST CONDITIONS	MIN	TYP	MAX	UNIT	
$t_{TLH}$ Transition time, low-to-high-level output	$R_L = 450\ \Omega$ , $C_L = 30\ \text{pF}$	$R_{WS} = 10\ \text{k}\Omega$	0.8	1.1	1.4	$\mu\text{s}$
		$R_{WS} = 100\ \text{k}\Omega$	8	11	14	
		$R_{WS} = 500\ \text{k}\Omega$	40	55	70	
		$R_{WS} = 1\ \text{M}\Omega$	80	110	140	
$t_{THL}$ Transition time, high-to-low-level output	$R_L = 450\ \Omega$ , $C_L = 30\ \text{pF}$	$R_{WS} = 10\ \text{k}\Omega$	0.8	1.1	1.4	$\mu\text{s}$
		$R_{WS} = 100\ \text{k}\Omega$	8	11	14	
		$R_{WS} = 500\ \text{k}\Omega$	40	55	70	
		$R_{WS} = 1\ \text{M}\Omega$	80	110	140	

### PARAMETER MEASUREMENT INFORMATION

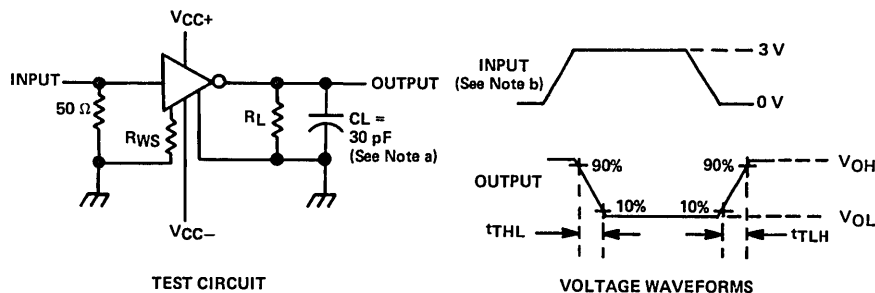

NOTES: a.  $C_L$  includes probe and jig capacitance.

b. The input pulse is supplied by a generator having the following characteristics:  $t_r < 10\ \text{ns}$ ,  $t_f = 10\ \text{ns}$ ,  $Z_{out} = 50\ \Omega$ ,  $\text{PRR} = 1\ \text{kHz}$ , duty cycle = 10%.

FIGURE 1 – TRANSITION TIMES

### TYPICAL APPLICATION DATA

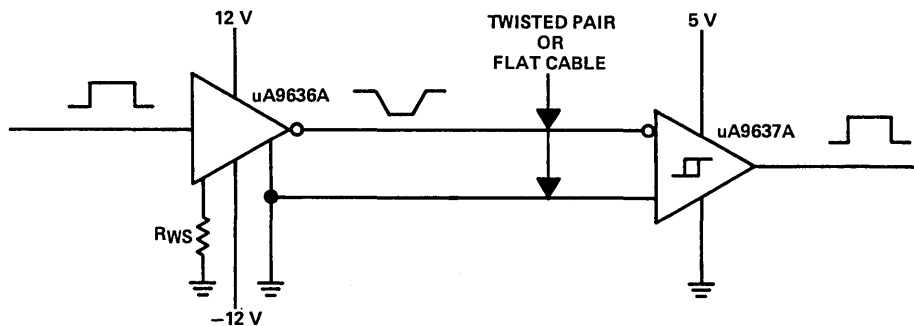

FIGURE 2 – RS-423 SYSTEM APPLICATION

**TEXAS INSTRUMENTS**  
INCORPORATED

POST OFFICE BOX 225012 • DALLAS, TEXAS 75265

# TYPE $\mu$ A9636AC

## DUAL LINE DRIVERS WITH ADJUSTABLE SLEW RATE

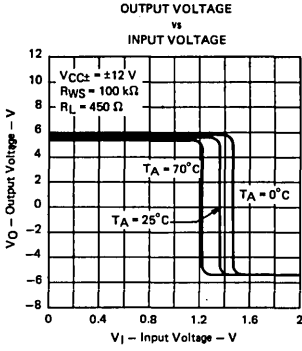

FIGURE 3

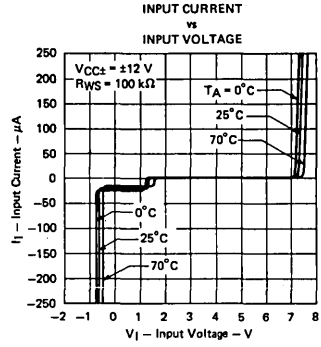

FIGURE 4

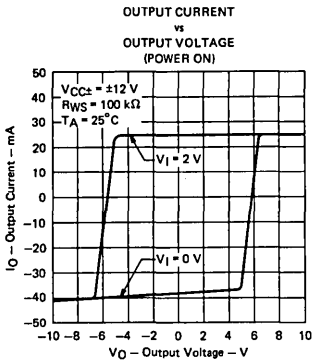

FIGURE 5

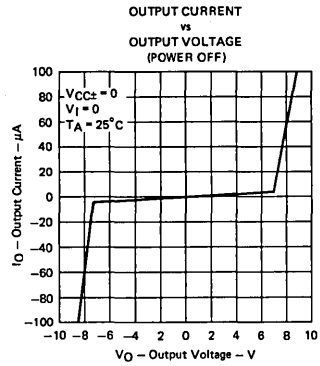

FIGURE 6

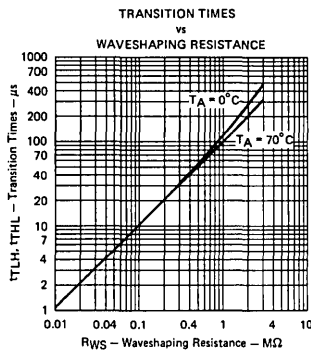

FIGURE 7

# INTERFACE CIRCUITS

# TYPE $\mu$ A9637AC DUAL DIFFERENTIAL LINE RECEIVER

BULLETIN NO. DL-S 12775, SEPTEMBER 1980

- Meets EIA Standards RS-422A and RS-423A
- Meets Federal Standards 1020 and 1030
- Operates from Single 5-V Power Supply
- Wide Common-Mode Input Voltage Range
- High Input Impedance
- TTL-Compatible Outputs
- High-Speed Schottky Circuitry
- 8-Pin Dual-In-Line Package

JG OR P DUAL-IN-LINE PACKAGE  
(TOP VIEW)

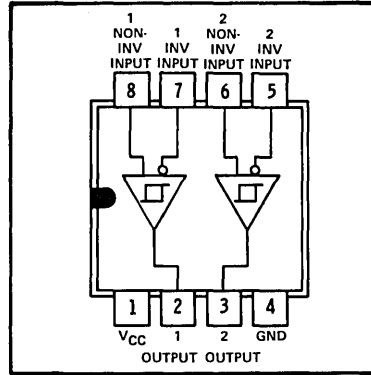

## description

The  $\mu$ A9637AC is a dual differential line receiver designed to meet EIA standards RS-422A and RS-423A. It utilizes Schottky<sup>†</sup> circuitry and has TTL-compatible outputs. The inputs are compatible with either a single-ended or a differential-line system. This device operates from a single 5-volt power supply and is supplied in an 8-pin dual-in-line package.

The  $\mu$ A9637AC is characterized for operation from 0°C to 70°C.

## schematics of inputs and outputs

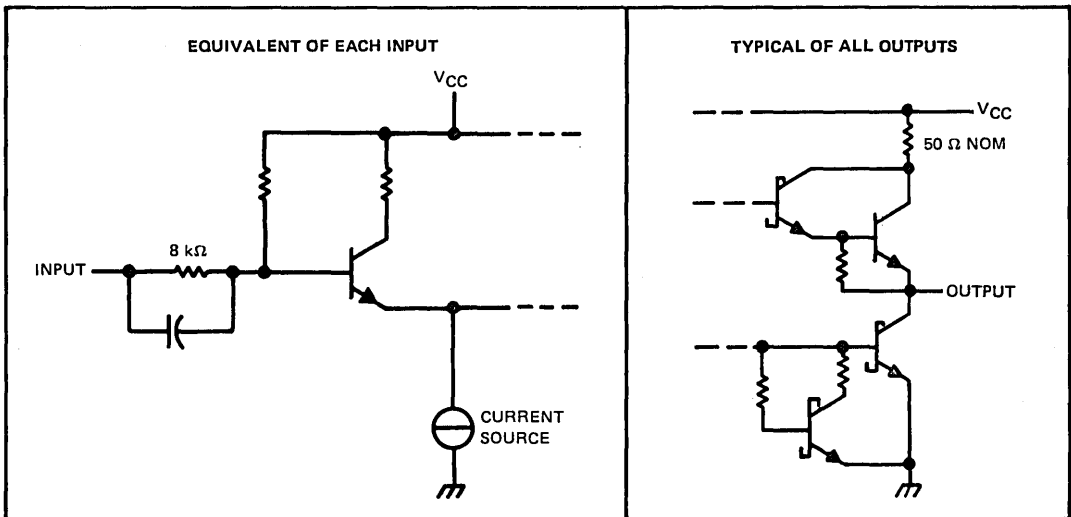

Copyright © 1980 by Texas Instruments Incorporated

**TEXAS INSTRUMENTS**  
INCORPORATED

POST OFFICE BOX 225012 • DALLAS, TEXAS 75265

<sup>†</sup>Integrated Schottky-Barrier diode-clamped transistor is patented by Texas Instruments. U.S. Patent Number 3,463,975.

5-255

# TYPE $\mu$ A9637AC DUAL DIFFERENTIAL LINE RECEIVER

absolute maximum ratings over operating free-air temperature range (unless otherwise noted)

Supply voltage range, $V_{CC}$ (see Note 1)	.....	-0.5 V to 7 V
Input voltage	.....	$\pm 15$ V
Differential input voltage (see Note 2)	.....	$\pm 15$ V
Output voltage (see Note 1)	.....	-0.5 V to 5.5 V
Low-level output current	.....	50 mA
Continuous total dissipation at (or below) 25°C free-air temperature (see Note 3):		
	JG package	825 mA
	P package	1000 mA
Operating free-air temperature range	.....	0°C to 70°C
Storage temperature range	.....	-65°C to 150°C
Lead temperature 1/16 inch (1,6 mm) from case for 60 seconds:	JG package	300°C
Lead temperature 1/16 inch (1,6 mm) from case for 10 seconds:	P package	260°C

- NOTES:
- All voltage values, except differential-input voltage, are with respect to the network ground terminal.
  - Differential-input voltage is measured at the noninverting input with respect to the corresponding inverting input.
  - For operation above 25°C free-air temperature, derate the JG package to 528 mW at 70°C at the rate of 6.6 mW/°C and the P package to 640 mW at 70°C at the rate of 8.0 mW/°C. In the JG package,  $\mu$ A9637AC chips are glass-mounted.

5

## recommended operating conditions

	MIN	NOM	MAX	UNIT
Supply voltage, $V_{CC}$	4.75	5	5.25	V
Common-mode input voltage, $V_{IC}$			$\pm 7$	V
Operating free-air temperature, $T_A$	0	25	70	°C

electrical characteristics over recommended ranges of supply voltage, common-mode input voltage, and operating free-air temperature (unless otherwise noted)

PARAMETER	TEST CONDITIONS	MIN	TYP <sup>†</sup>	MAX	UNIT
		See Note 4			
$V_T$ Threshold voltage ( $V_{T+}$ and $V_{T-}$ )		-0.2	0.2	0.2	V
	See Note 5	-0.4		0.4	
$V_{T+} - V_{T-}$ Hysteresis			70		mV
$V_{OH}$ High-level output voltage	$V_{ID} = 0.2$ V, $I_O = -1$ mA	2.5	3.5		V
$V_{OL}$ Low-level output voltage	$V_{ID} = -0.2$ V, $I_O = 20$ mA	0.35	0.5		V
$I_I$ Input current	$V_{CC} = 0$ to 5.5 V, See Note 6	$V_I = 10$ V	1.1	3.25	mA
		$V_I = -10$ V	-1.6	-3.25	
$I_{OS}$ Short-circuit input current <sup>‡</sup>	$V_O = 0$ , $V_{ID} = 0.2$ V	-40	-75	-100	mA
$I_{CC}$ Supply current	$V_{ID} = -0.5$ V, No load		35	50	mA

<sup>†</sup>All typical values are at  $V_{CC} = 5$  V,  $T_A = 25^\circ$  C.

<sup>‡</sup>Only one output should be shorted at a time, and duration of the short-circuit should not exceed one second.

- NOTES:
- The algebraic convention, where the less-positive (more-negative) limit is designated as minimum, is used in this data sheet for threshold levels only.
  - The expanded threshold parameter is tested with a 500- $\Omega$  resistor in series with each input.
  - The input not under test is grounded.

switching characteristics,  $V_{CC} = 5$  V,  $T_A = 25^\circ$  C

PARAMETER	TEST CONDITION	MIN	TYP	MAX	UNIT
$t_{PLH}$ Propagation delay time, low-to-high-level output	$C_L = 30$ pF, See Figure 1		15	25	ns
$t_{PHL}$ Propagation delay time, high-to-low-level output			13	25	ns



# TYPE $\mu$ A9637AC DUAL DIFFERENTIAL LINE RECEIVER

## PARAMETER MEASUREMENT INFORMATION

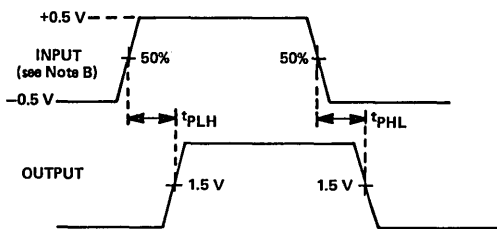
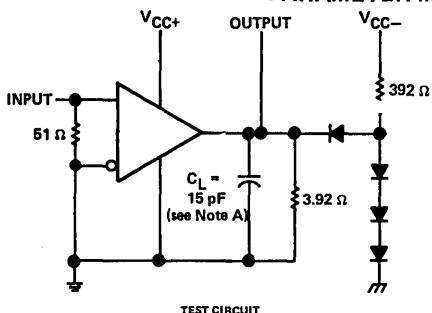

NOTES: A.  $C_L$  includes probe and jig capacitance.

B. The input pulse is supplied by a generator having the following characteristics:  $t_r \leq 5$  ns,  $t_f = 5$  ns, PRR = 5 MHz, duty cycle = 10%.

FIGURE 1—TRANSITION TIMES

## TYPICAL CHARACTERISTICS

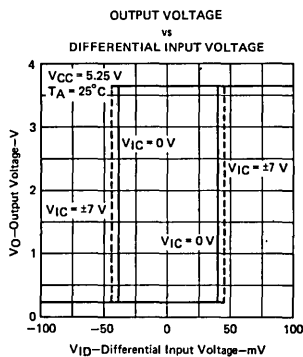
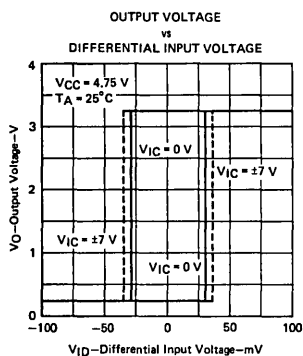

## TYPICAL APPLICATION DATA

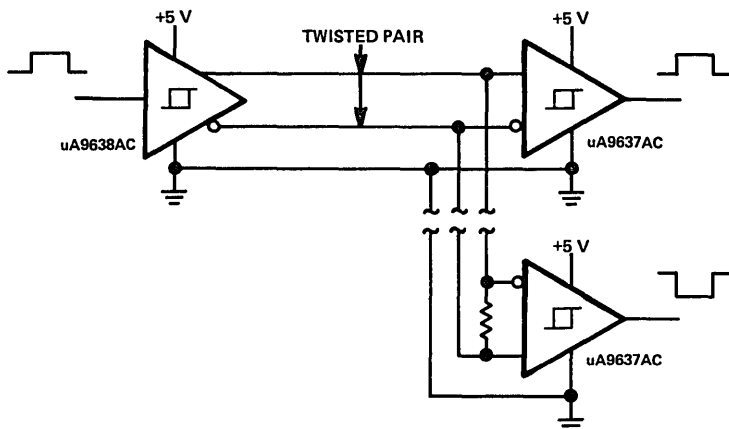

**TEXAS INSTRUMENTS**  
INCORPORATED

POST OFFICE BOX 225012 • DALLAS, TEXAS 75265

# INTERFACE CIRCUITS

# TYPE $\mu$ A9638C DUAL HIGH-SPEED DIFFERENTIAL LINE DRIVER

BULLETIN NO. DL-S 12780, OCTOBER 1980

- Meets EIA Standard RS-422A
- Operates From a Single 5-V Supply
- TTL and CMOS Input Compatibility
- Output Short-Circuit Protection
- Schottky Circuitry
- Designed to be Interchangeable with Fairchild 9638

## description

The  $\mu$ A9638C is a dual high-speed differential line driver designed to meet EIA Standard RS-422A. The inputs are TTL- and CMOS-compatible and have input clamp diodes. Schottky-diode-clamped transistors<sup>†</sup> are used to minimize propagation delay time. This device operates from a single 5-volt power supply and is supplied in an 8-pin dual-in-line package.

The  $\mu$ A9638C is characterized for operation from 0°C to 70°C.

## schematics of inputs and outputs

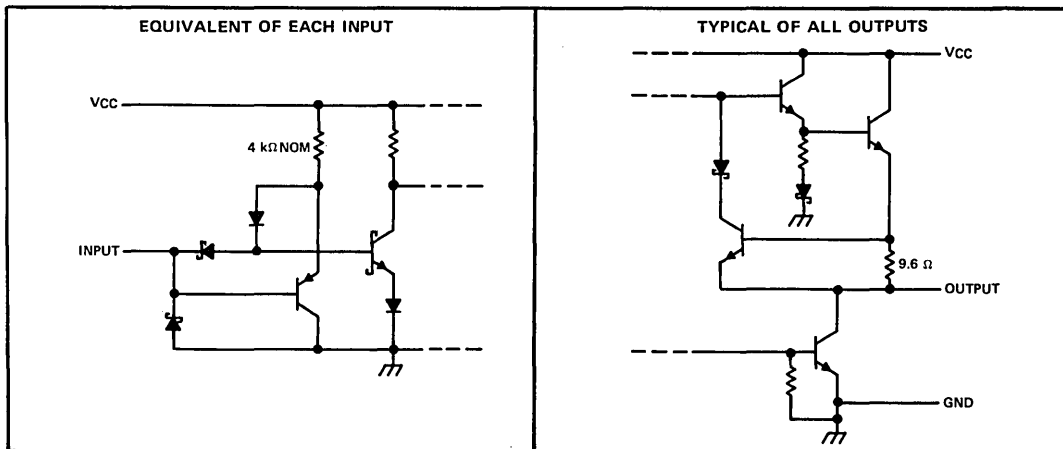

JG OR P DUAL-IN-LINE PACKAGE  
(TOP VIEW)

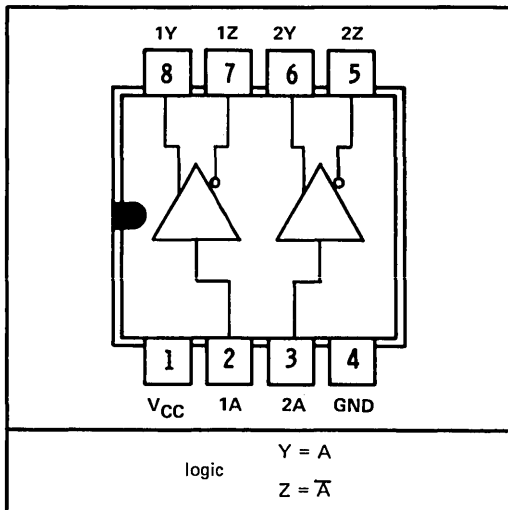

5

## absolute maximum rating over operating free-air temperature range (unless otherwise noted)

Supply voltage range, $V_{CC}$ (see Note 1)	.....	-0.5 V to 7 V
Input voltage range	.....	-0.5 V to 7 V
Continuous total dissipation at (or below) 25°C free-air temperature (see Note 2):	.....	800 mW
Operating free-air temperature range	.....	0°C to 70°C
Storage temperature range	.....	-65°C to 150°C
Lead temperature 1/16 inch (1,6 mm) from case for 30 seconds: JG package	.....	300°C
Lead temperature 1/16 inch (1,6 mm) from case for 10 seconds: P package	.....	260°C

NOTES: 1. Voltage values except differential output voltages are with respect to the network ground terminal.  
2. For operation above 25°C free-air temperature, refer to Dissipation Derating Table.

Copyright © 1980 by Texas Instruments Incorporated

**TEXAS INSTRUMENTS**  
INCORPORATED

<sup>†</sup>Integrated Schottky-Barrier diode-clamped transistor is patented by Texas Instruments. U.S. Patent Number 3,463,975.

# TYPE $\mu$ A9638C

## DUAL HIGH-SPEED DIFFERENTIAL LINE DRIVER

DISSIPATION DERATING TABLE

PACKAGE	POWER RATING	DERATING FACTOR	ABOVE $T_A$
JG (Glass-Mounted Chip)	800 mW	$6.6 \text{ mW}/^\circ\text{C}$	$29^\circ\text{C}$
P	800 mW	$8.0 \text{ mW}/^\circ\text{C}$	$50^\circ\text{C}$

recommended operating conditions

	MIN	NOM	MAX	UNIT
Supply voltage, $V_{CC}$	4.75	5	5.25	V
High-level output current, $I_{OH}$			-50	mA
Low-level output current, $I_{OL}$			50	mA
Operating free-air temperature, $T_A$	0		70	$^\circ\text{C}$

electrical characteristics over operating free-air temperature range (unless otherwise noted)

PARAMETER	TEST CONDITIONS <sup>†</sup>	MIN	TYP <sup>†</sup>	MAX	UNIT
$V_{IH}$	High-level input voltage	2			V
$V_{IL}$	Low-level input voltage			0.8	V
$V_{IK}$	Input clamp voltage	$V_{CC} = 4.75 \text{ V}, I_I = -18 \text{ mA}$		-1 -1.2	V
$V_{OH}$	High level output voltage	$V_{CC} = 4.75 \text{ V}, V_{IH} = 2 \text{ V}, V_{IL} = 0.8 \text{ V}$		2.5 3.5	V
				$I_{OH} = -10 \text{ mA}$ $I_{OH} = -40 \text{ mA}$	
$V_{OL}$	Low-level output voltage	$V_{CC} = 4.75 \text{ V}, V_{IH} = 2 \text{ V}, I_{OL} = 40 \text{ mA}, V_{IL} = 0.8 \text{ V}$		0.5	V
$V_{OD1}$	Differential output voltage	$V_{CC} = 5.25 \text{ V}, I_O = 0$		$2V_{OD2}$	V
$V_{OD2}$	Differential output voltage	2			V
$\Delta V_{OD}$	Change in magnitude of <sup>‡</sup> differential output voltage	$V_{CC} = 4.75 \text{ V to } 5.25 \text{ V}, R_L = 100 \Omega$ , See Figure 1		$\pm 0.4$	V
$V_{OC}$	Common-mode output voltage <sup>§</sup>			3	V
$\Delta V_{OC}$	Change in magnitude of <sup>‡</sup> common-mode output voltage			$\pm 0.4$	V
$I_O$	Output current with power off	$V_{CC} = 0,$		0.1 -0.1	100 -100
				$V_O = 6 \text{ V}$ $V_O = -0.25 \text{ V}$ $V_O = -0.25 \text{ V to } 6 \text{ V}$	$\mu\text{A}$
$I_I$	Input current	$V_{CC} = 5.25 \text{ V}, V_I = 5.5 \text{ V}$		50	$\mu\text{A}$
$I_{IH}$	High-level input current	$V_{CC} = 5.25 \text{ V}, V_I = 2.7 \text{ V}$		25	$\mu\text{A}$
$I_{IL}$	Low-level input current	$V_{CC} = 5.25 \text{ V}, V_I = 0.5 \text{ V}$		-200	$\mu\text{A}$
$I_{OS}$	Short-circuit output current <sup>¶</sup>	$V_{CC} = 5.25 \text{ V},$		-50 -150	mA
$I_{CC}$	Supply current (all drivers)	$V_{CC} = 5.25 \text{ V},$ No load, All inputs at 0 V		45 65	mA

<sup>†</sup>All typical values are at  $V_{CC} = 5 \text{ V}$  and  $T_A = 25^\circ\text{C}$ .

<sup>‡</sup> $\Delta V_{OD}$  and  $\Delta V_{OC}$  are the changes in magnitude of  $V_{OD}$  and  $V_{OC}$ , respectively, that occur when the input is changed from a high level to a low level.

<sup>§</sup>In EIA Standard RS-422A,  $V_{OC}$ , which is the average of the two output voltages with respect to ground, is called output offset voltage,  $V_{OS}$ .

<sup>¶</sup>Only one output at a time should be shorted and duration of the short-circuit should not exceed one second.

5

# TYPE $\mu$ A9638C

## DUAL HIGH-SPEED DIFFERENTIAL LINE DRIVER

switching characteristics,  $V_{CC} = 5\text{ V}$ ,  $T_A = 25^\circ\text{C}$

PARAMETER	TEST CONDITION	MIN	TYP	MAX	UNIT
$t_{DD}$	$C_L = 15\text{ pF}$ , $R_L = 100\ \Omega$ , See Figure 2		10	15	ns
$t_{TD}$			10	15	ns
Skew			1		ns

### PARAMETER MEASUREMENT INFORMATION

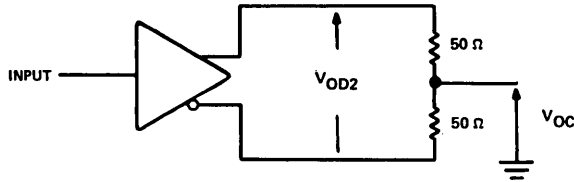
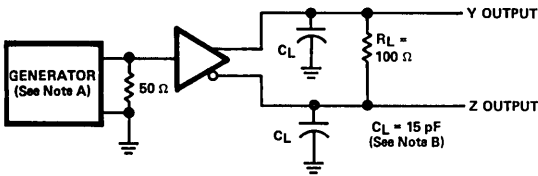
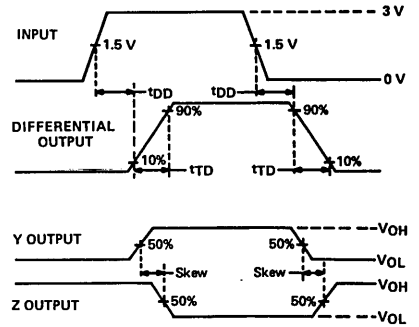

FIGURE 1—DIFFERENTIAL AND COMMON-MODE OUTPUT VOLTAGES



TEST CIRCUIT



VOLTAGE WAVEFORM

- NOTES:
- The input pulse generator has the following characteristics:  $Z_{OUT} = 50\ \Omega$ ,  $PRR = 500\text{ kHz}$ ,  $t_w = 100\text{ ns}$ ,  $t_r = < 5\text{ ns}$ .
  - $C_L$  includes probe and jig capacitance.

FIGURE 2—SWITCHING TIMES

# LINE CIRCUITS APPLICATION INFORMATION

---

## introduction

The systems designer is constantly faced with the problem of interfacing subsystems and of transmitting data over a distance, whether it is a few inches on a circuit board or many feet to another unit in the system. The quality of the signal reproduced in the receiving unit is dependent on:

- A. Transmission line characteristics
  - 1. Length and attenuation
  - 2. Geometry (single wire, coaxial, parallel wires, twisted pair, shielded or unshielded, etc.)
    - a. Characteristic impedance and line termination
    - b. Distributed capacitance and inductance
- B. General layout and noise environment
- C. Receiver characteristics
  - 1. Input impedance
  - 2. Sensitivity, hysteresis, and input threshold
  - 3. Frequency response (switching time)
- D. Driver characteristics
  - 1. Output impedance
  - 2. Output peak current capability
  - 3. Frequency response
- E. Bit rate and pulse duration ( bit rate =  $\frac{2}{\text{period}}$  )

The impact of many of these factors is discussed on the following pages and in several data sheets. Other applications where line circuit characteristics can be used to advantage are also discussed. For convenient access to all the application information in this data book, a topical index is provided on the next page.

## additional circuit design information

Bulletin CA-130, *Line Drivers and Receivers: SN55107 Series*, and Bulletin CA-146, *Data Transmission with SN55107 Series*, are available from Texas Instruments upon request.

The Texas Instruments videotape course "Linear and Interface Integrated Circuits" is available for a nominal fee.

# LINE CIRCUITS APPLICATION INFORMATION

---

## INDEX TO APPLICATION TOPICS

Interfacing to IEEE Standard 488 GPIB .....	5-6
EIA Standards .....	5-8
Party-line system for quadruple bus transceivers .....	5-24
Party-line operation for drivers with 3-state outputs .....	5-30
Basic balanced-line transmission system .....	5-44, 5-66
Party-line system .....	5-55, 5-66, 5-250
Unbalanced or single-line systems .....	5-56, 5-106
Dot-AND connections .....	5-56
Increasing receiver common-mode input voltage range .....	5-56
Furnace control .....	5-58
Dual differential comparator .....	5-59
Repeater for long lines .....	5-59
Window detector .....	5-59
Temperature controller with zero-voltage switching .....	5-60
Pulse control circuit .....	5-66
Balanced party-line system .....	5-86
Single-ended party-line circuits .....	5-100
Pulse-squaring circuit .....	5-100
Voltage waveforms on unbalanced transmission lines .....	5-124
Line receiver circuit with adjustable voltage reference .....	5-132, 5-152
Schmitt trigger circuit .....	5-133
Gated oscillator .....	5-133
Level detector .....	5-133
Interface circuits for MIL STD 188C .....	5-138, 5-144
Interface circuits for EIA Standard RS-232-C .....	5-144, 5-240
Balanced Bus Transmission with up to 32 driver/receiver pairs .....	5-190
Differential line extender (Transceiver) .....	5-222
Differential-line transmission using SN75182 and SN75183 .....	5-133
Logic translator circuit .....	5-240
MOS-memory sense amplifier .....	5-250
RS-423 system applications .....	5-253
RS-422A system applications .....	5-257
Line terminations .....	5-263
Noise .....	5-266
Line length capability versus bit rate .....	5-268

# LINE CIRCUITS APPLICATION INFORMATION

## line terminations

The voltage across an impedance terminating a transmission line is a function of the real and imaginary components of the impedance, the characteristic impedance of the line, and the incident power. When the impedance is a pure resistance (see Note 1) and the transmission line is ideal, then:

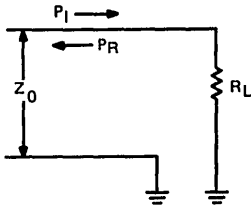

FIGURE 1

$$P_R = P_I \left( \frac{R_L - Z_0}{R_L + Z_0} \right)^2 \quad (1)$$

$$P_L = P_I - P_R = P_I \left[ 1 - \left( \frac{R_L - Z_0}{R_L + Z_0} \right)^2 \right] \quad (2)$$

$$V_L = \sqrt{P_L R_L} = \sqrt{I_L^2 R_L^2} \quad (3)$$

where

$P_I$  = incident power       $P_L$  = power delivered to  $R_L$

$P_R$  = reflected power       $Z_0$  = line characteristic impedance

$R_L$  = load resistance

When  $R_L = Z_0$ , the numerators of the fractional terms in Equations 1 and 2 become zero and the reflected power is zero. With reflections reduced to zero, one source of signal distortion and noise is eliminated. Equation 3 shows the relationship between  $P_L$ ,  $R_L$ ,  $V_L$ , and  $I_L$ .

5

In line circuit design  $R_L$  is a lumped value representing the combination of a termination resistor and the input resistance of a line receiver.

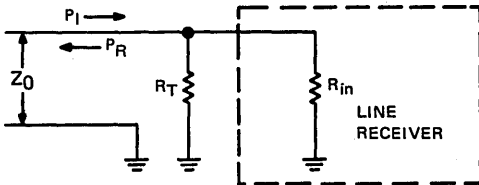

FIGURE 2

$$V_L = \sqrt{P_L \frac{R_{in} \times R_T}{R_{in} + R_T}} \quad (4)$$

When  $R_{in} \gg R_T$ , the incoming signal power and noise power are shunted to ground by  $R_T$ , decreasing the effective power to the input of the receiver.

NOTE 1: The assumption that the terminating impedance is a pure resistance simplifies this discussion. In practice, the reactive components of impedance can usually be neglected.

TEXAS INSTRUMENTS  
INCORPORATED

POST OFFICE BOX 225012 • DALLAS, TEXAS 75265

5-263

# LINE CIRCUITS APPLICATION INFORMATION

## line terminations (continued)

Figure 3 illustrates how much the line length versus bit rate boundary for acceptable TTL signals was affected by variation of the termination resistor values. Case A clearly provides the best capability for high bit rates and long transmission lines, while Cases B and C show irregularities primarily due to reflected signals.

	R1	R2
Case A	100 $\Omega$	100 $\Omega$
Case B	$\infty$	100 $\Omega$
Case C	$\infty$	122 $\Omega$
Case D	$\infty$	205 $\Omega$

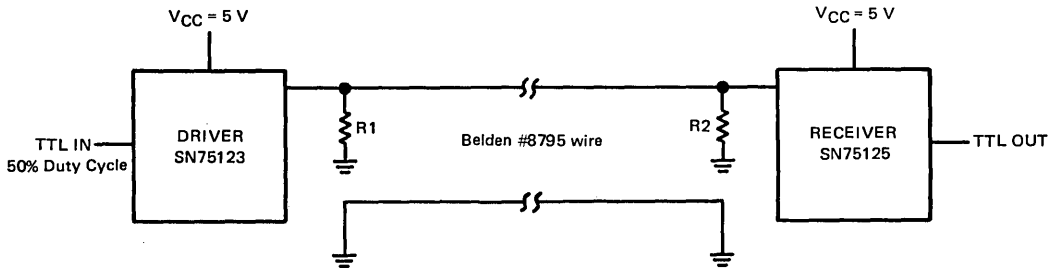
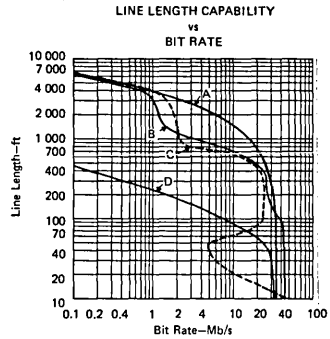
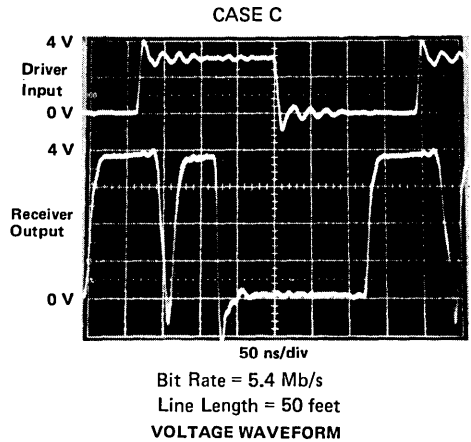

FIGURE 3

The voltage waveform for Case C at a line length of 50 feet shows a large negative transient in the receiver output due to a reflection. At 10 feet, the bit rate capability (see Figure 3) has increased to 45 Mb/s compared to 47 Mb/s for Case B.





# LINE CIRCUITS APPLICATION INFORMATION

## line terminations (continued)

The waveforms below offer an interesting comparison of the driver input signal to the resulting signals that appear at the receiver input and at the receiver output. The circuit of Figure 3 with 100 feet of line and a bit rate of 2 Mb/s was used. Note that the pulse duration for Case D receiver output is much shorter than the apparent duration of the input pulse. Case C, with somewhat less distortion, produces input and output pulse widths of about the same value.

### VOLTAGE WAVEFORMS

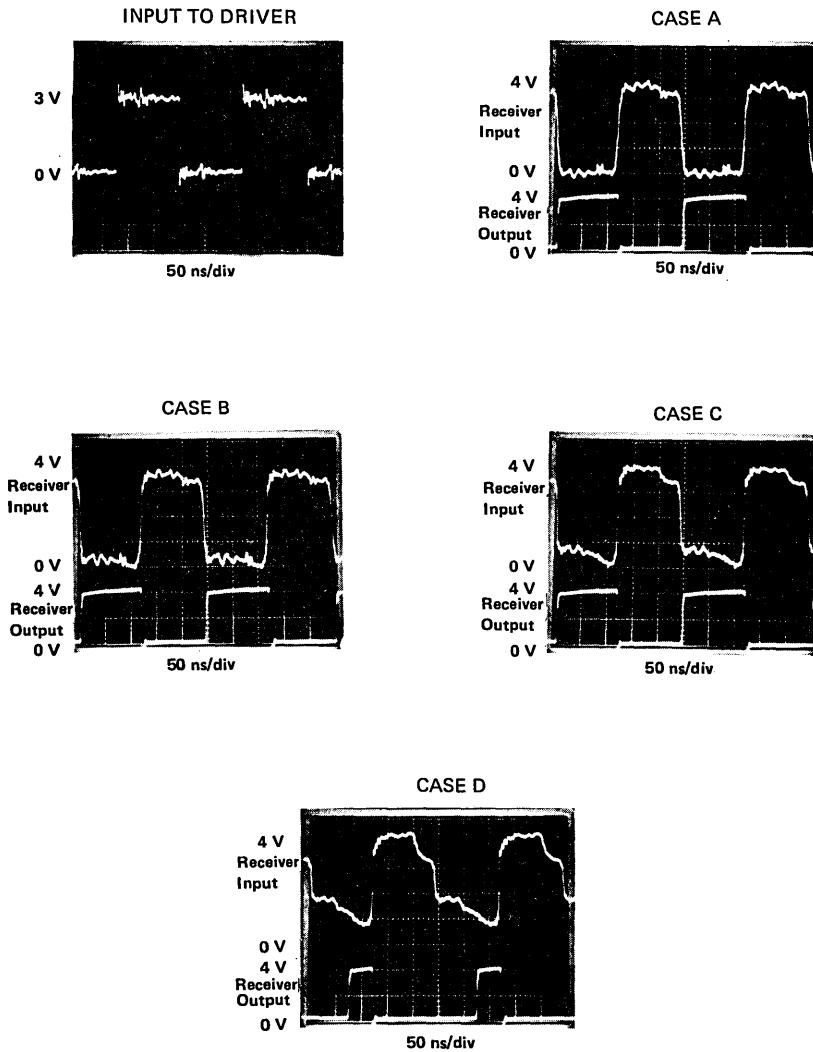

# LINE CIRCUITS

## APPLICATION INFORMATION

### noise

The environment of any transmission line will produce noise from many sources. That noise will be transmitted to the input of the line receiver and can cause severe signal distortion. The familiar differential-line technique has provided a means of reducing the effect of common-mode noise on low-level signals in linear, digital, and rf transmission for some time, and is thoroughly discussed in the literature. One method of reducing the common-mode noise on balanced lines will be presented in this topic.

The noise power present on a line terminated in a resistance will act in the same manner as the signal power in Equations 1 through 4 under Line Terminations. Specifically, the noise will be shunted to ground and will not provide power to the receiver input if the line is terminated in a low-value resistor to ground. Examples 1 and 2 below show two typical means of terminating differential lines at the receiver.

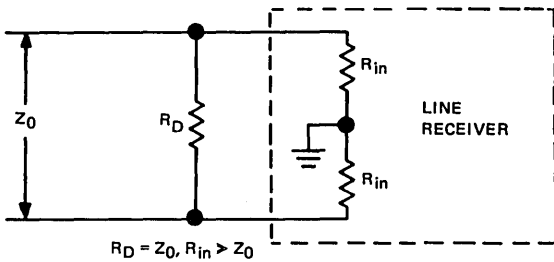

EXAMPLE 1

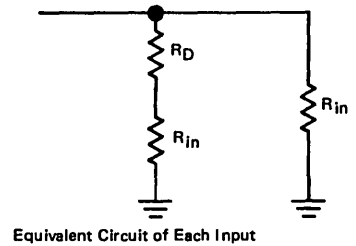

Since the shunting resistance,  $R_D + R_{in}$ , is high, most of the noise on each conductor will appear at the receiver input.

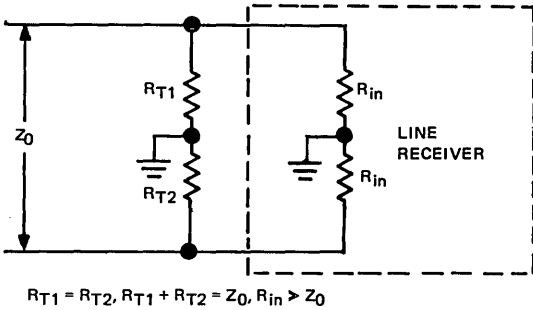

EXAMPLE 2

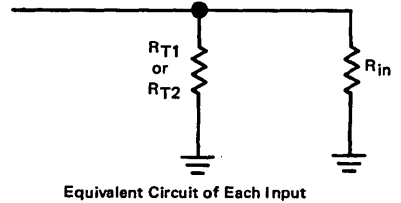

Most of the noise power on each conductor of the balanced line will be shunted to ground by  $R_{T1}$  or  $R_{T2}$  because of their low value compared to  $R_{in}$ .

# LINE CIRCUITS APPLICATION INFORMATION

noise (continued)

Figure 1 below illustrates the effectiveness of the differential-line technique in rejecting noise from an external source.

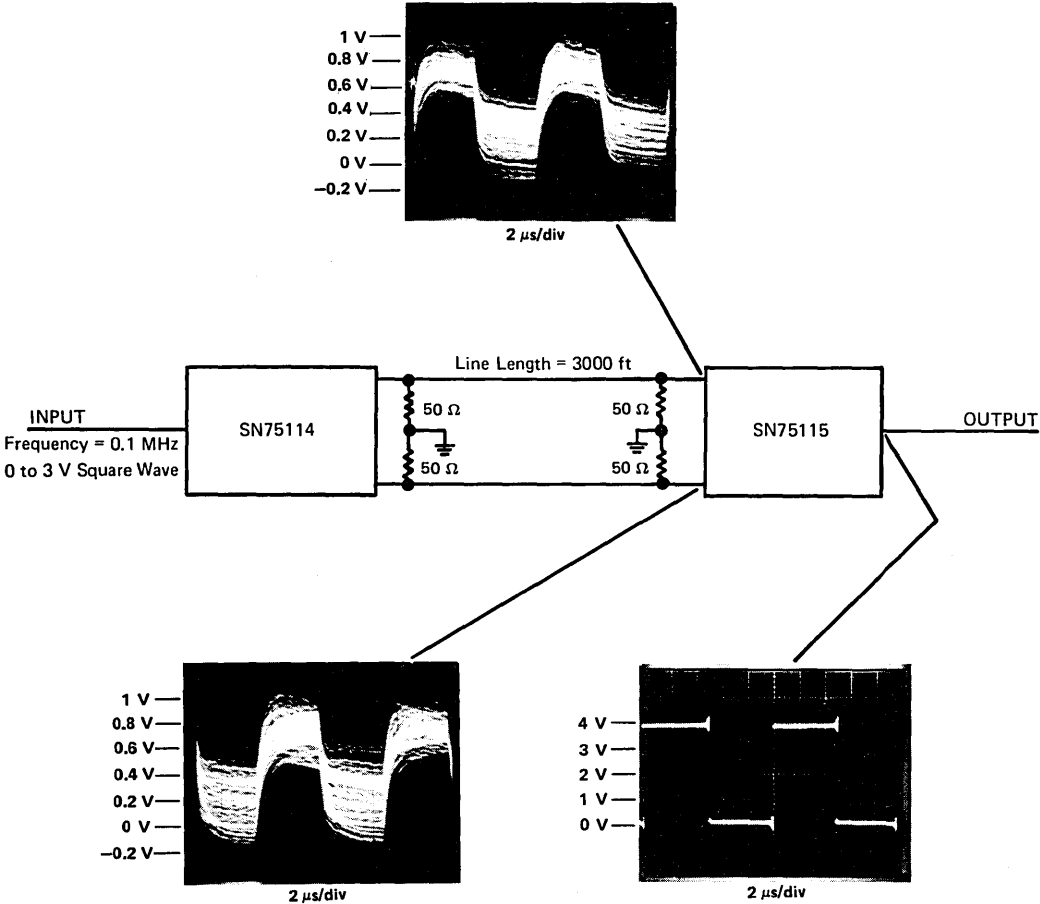

FIGURE 1

# LINE CIRCUITS

## APPLICATION INFORMATION

### line length capability vs bit rate

The data presented in this section is intended to assist the designer who must choose a combination of line driver and receiver to meet line length and bit rate requirements. It does not represent the complete set of available options, but offers a means of comparison for many device types in typical applications. Each graph is associated with a specific line termination scheme, and all measurements utilized Belden #8795 wire as transmission line (see Note 1).

The duty cycle value refers to the time at TTL high level divided by the period length.

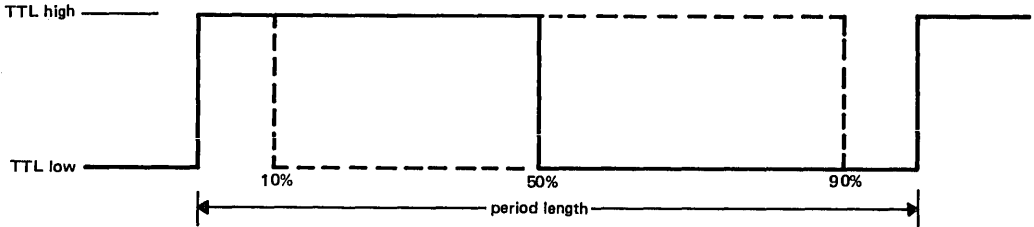

FIGURE 1— PERIOD AND DUTY CYCLE

Duty cycle and bit rate values will yield the high-level pulse duration by means of the formula:

$$\text{Pulse duration} = \text{period} \times \text{duty cycle} = \frac{2}{\text{bit rate}} \times \text{duty cycle}$$

The data on the following pages was obtained in each case by monitoring the output of the receiver. Acceptable waveforms exhibited:

1. TTL low level less than 0.4 V
2. TTL high level greater than 2.4 V
3. No oscillations

Figures 2 and 3 show examples of acceptable and unacceptable voltage waveforms with regard to oscillations of the SN75112 driver and SN75207 receiver.

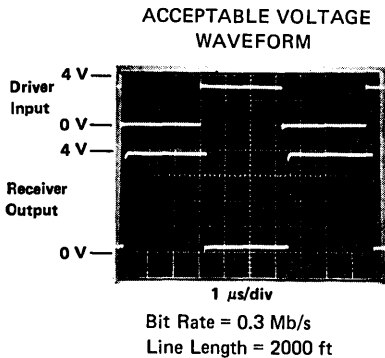

FIGURE 2

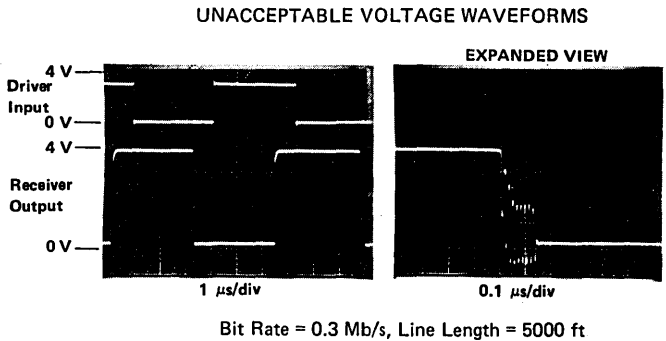

FIGURE 3

NOTE 1: Belden #8795 twisted-pair wire is 22 AWG and exhibits the following characteristics:  $Z_0 \approx 100 \Omega$ ,  $C \approx 15 \text{ pF/ft}$ , propagation delay  $\approx 1.3 \text{ ns/ft}$ .

# LINE CIRCUITS APPLICATION INFORMATION

---

## LINE LENGTH CAPABILITY vs BIT RATE

### INDEX TO DATA

DRIVER APPLICATIONS		RECEIVER APPLICATIONS	
TYPE	FIGURE NUMBERS	TYPE	FIGURE NUMBERS
SN75109A	4, 7	SN75107A	4, 5, 6
SN75110A	5, 8	SN75108A	7, 8, 9
SN75112	6, 9	SN75115	13, 14, 15, 16, 21
SN75113	10, 13	SN75116	42
SN75114	10, 13	SN75117	43
SN75116	42	SN75122	17, 22, 26, 31
SN75117	43	SN75124	27, 32
SN75121	31	SN75125	28, 33
SN75123	32, 33	SN75127	28, 33
SN75138	34	SN75138	34
SN75150	37, 38	SN75140	18, 23, 29
SN75158	41	SN75152	19, 24, 30, 38, 44
SN75183	11, 14	SN75154	37
SN75188	35, 36, 39, 40	SN75182	10, 11, 12, 20, 25
SN75450B	44	SN75189	35, 39
SN75451B	16, 17, 18, 19, 20	SN75189A	36, 40
SN75361A	21, 22, 23, 24, 25	SN75207	4, 5, 6
DS8831	12, 15, 26, 27, 28, 29, 30	SN75208	7, 8, 9, 41
DS8832	12, 15, 26, 27, 28, 29, 30		

5

# LINE CIRCUITS APPLICATION INFORMATION

## LINE LENGTH CAPABILITY vs BIT RATE

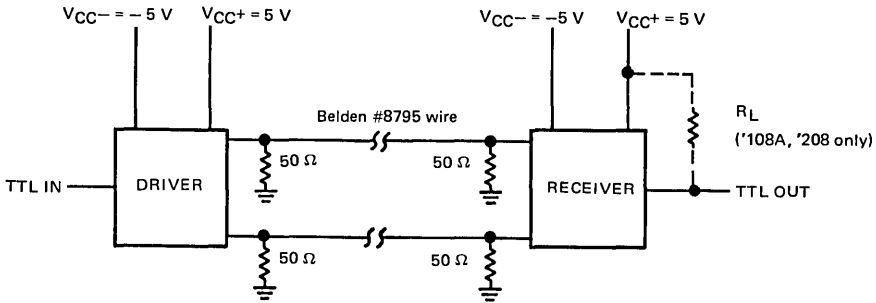

### MEASUREMENT INFORMATION FOR FIGURES 4 THRU 9

5

DRIVER . . . . . SN75109A  
RECEIVER SN75107A, SN75207

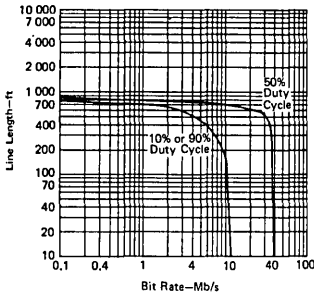

FIGURE 4

DRIVER . . . . . SN75110A  
RECEIVER SN75107A, SN75207

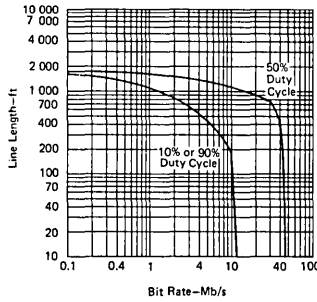

FIGURE 5

DRIVER . . . . . SN75112  
RECEIVER SN75107A, SN75207

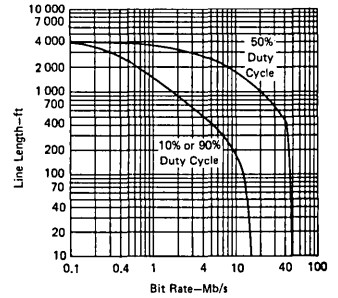

FIGURE 6

DRIVER . . . . . SN75109A  
RECEIVER SN75108A, SN75208

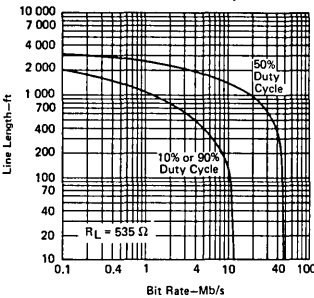

FIGURE 7

DRIVER . . . . . SN75110A  
RECEIVER SN75108A, SN75208

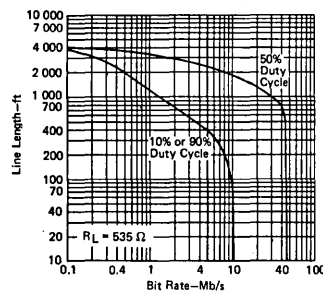

FIGURE 8

DRIVER . . . . . SN75112  
RECEIVER SN75108A, SN75208

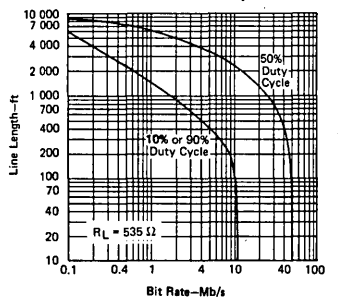
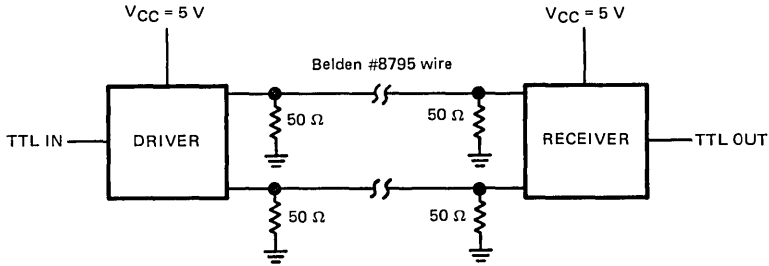

FIGURE 9

# LINE CIRCUITS APPLICATION INFORMATION

## LINE LENGTH CAPABILITY vs BIT RATE



MEASUREMENT INFORMATION FOR FIGURES 10 THRU 15

DRIVER . . . SN75113, SN75114  
RECEIVER . . . . SN75182

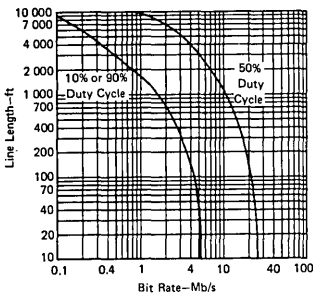

FIGURE 10

DRIVER . . . . . SN75183  
RECEIVER . . . . SN75182

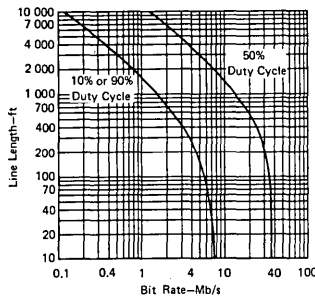

FIGURE 11

DRIVER . . . DS8831, DS8832  
RECEIVER . . . . SN75182

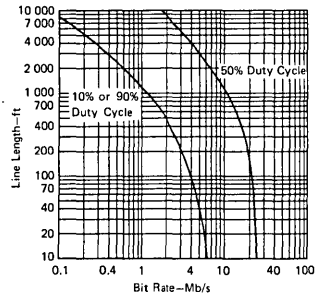

FIGURE 12

DRIVER . . SN75113, SN75114  
RECEIVER . . . . SN75115

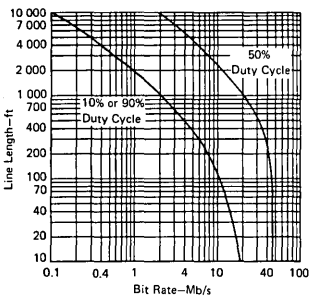

FIGURE 13

DRIVER . . . . . SN75183  
RECEIVER . . . . SN75115

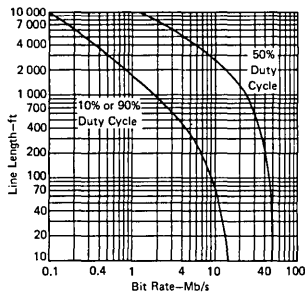

FIGURE 14

DRIVER . . . DS8831, DS8832  
RECEIVER . . . . SN75115

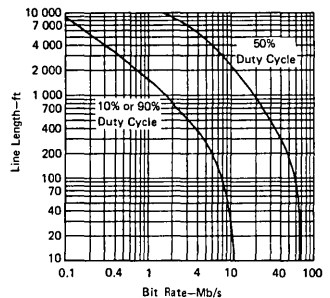
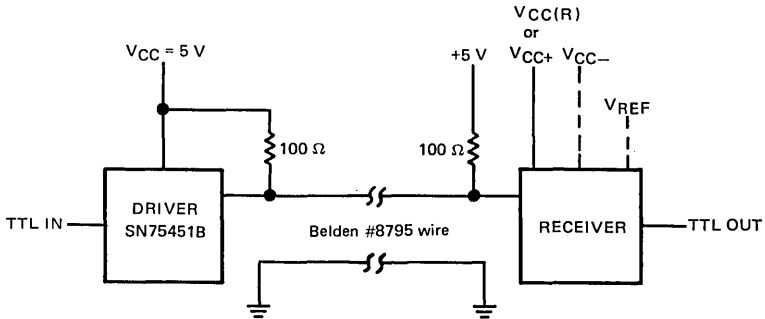

FIGURE 15

# LINE CIRCUITS APPLICATION INFORMATION

## LINE LENGTH CAPABILITY vs BIT RATE



### MEASUREMENT INFORMATION FOR FIGURES 16 THRU 20

RECEIVER . . . .SN75115

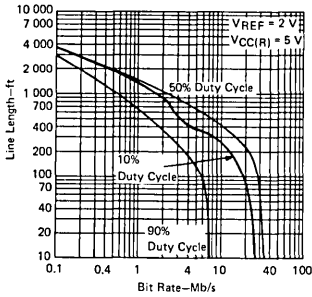

FIGURE 16

RECEIVER . . . .SN75122

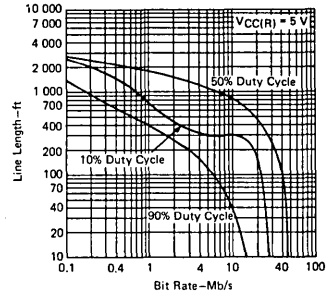

FIGURE 17

RECEIVER . . . .SN75140

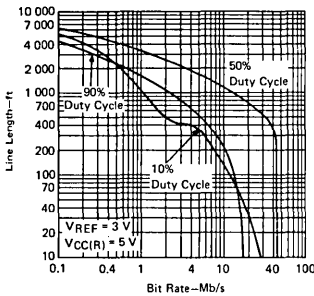

FIGURE 18

RECEIVER . . . .SN75152

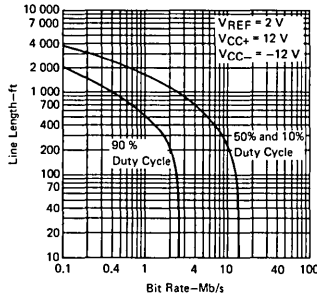

FIGURE 19

RECEIVER . . . .SN75182

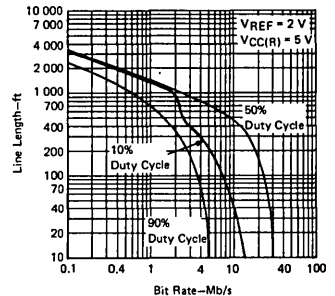
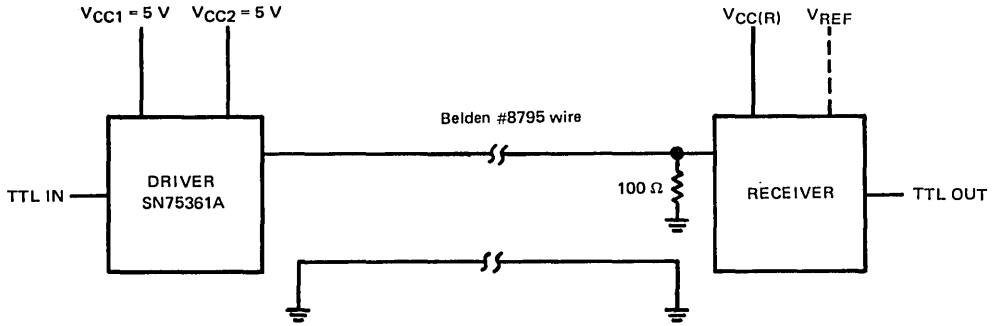

FIGURE 20



# LINE CIRCUITS APPLICATION INFORMATION

## LINE LENGTH CAPABILITY vs BIT RATE



MEASUREMENT INFORMATION FOR FIGURES 21 THRU 25

RECEIVER . . . .SN75115

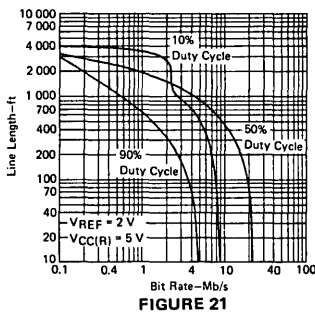

FIGURE 21

RECEIVER . . . .SN75122

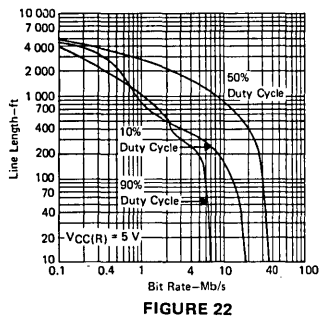

FIGURE 22

RECEIVER . . . .SN75140

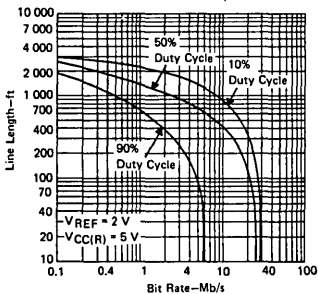

FIGURE 23

RECEIVER . . . .SN75152

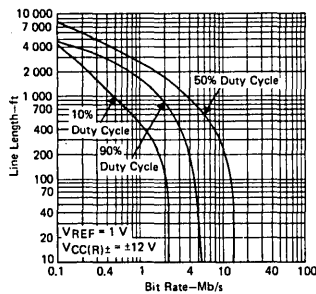

FIGURE 24

RECEIVER . . . .SN75182

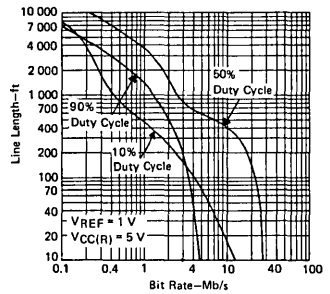
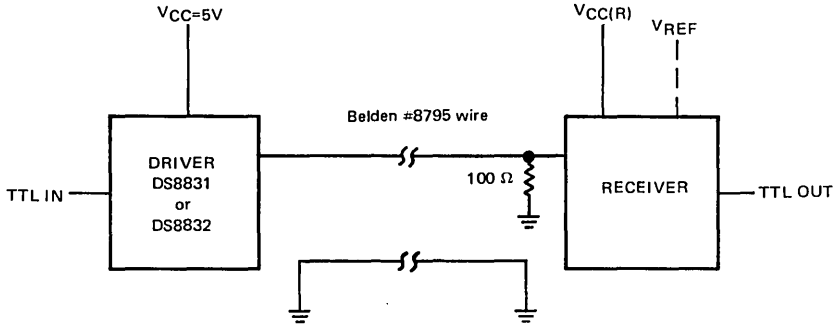

FIGURE 25

# LINE CIRCUITS APPLICATION INFORMATION

## LINE LENGTH CAPABILITY vs BIT RATE



MEASUREMENT INFORMATION FOR FIGURES 26 THRU 30

RECEIVER . . . SN75122

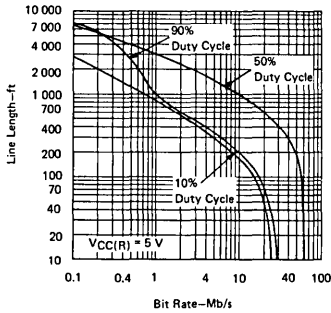

FIGURE 26

RECEIVER . . . SN75124

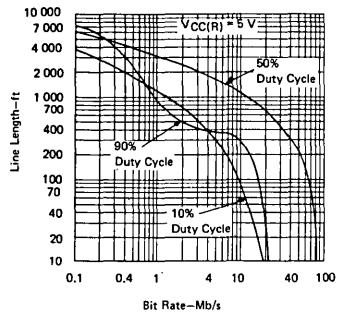

FIGURE 27

RECEIVER SN75125, SN75127

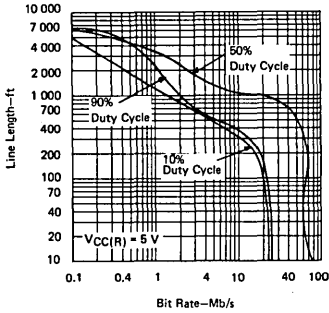

FIGURE 28

RECEIVER . . . SN75140

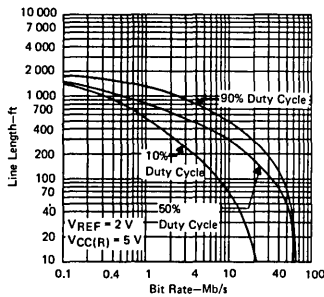

FIGURE 29

RECEIVER . . . SN75152

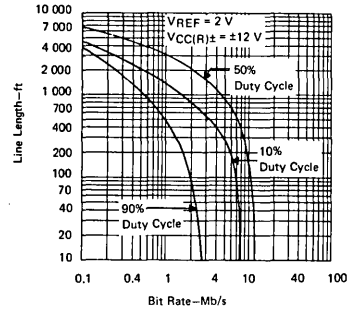
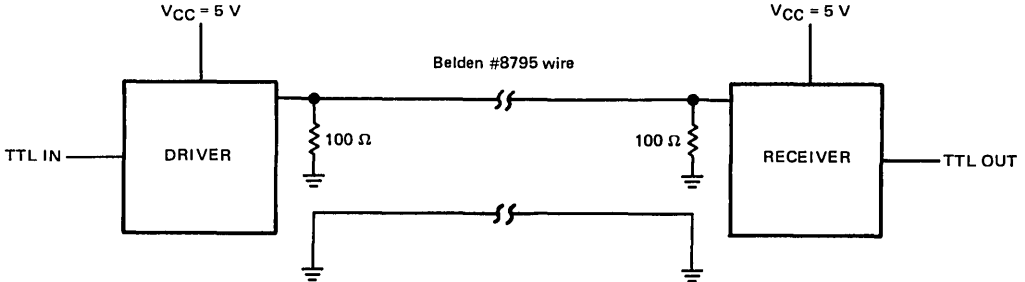

FIGURE 30

# LINE CIRCUITS APPLICATION INFORMATION

## LINE LENGTH CAPABILITY vs BIT RATE



MEASUREMENT INFORMATION FOR FIGURES 31 THRU 33

DRIVER . . . . .SN75121  
RECEIVER . . . . .SN75122

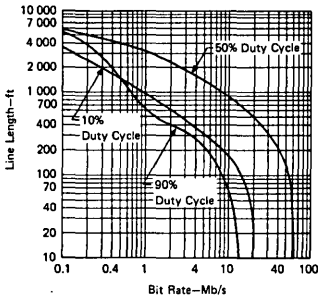

FIGURE 31

DRIVER . . . . .SN75123  
RECEIVER . . . . .SN75124

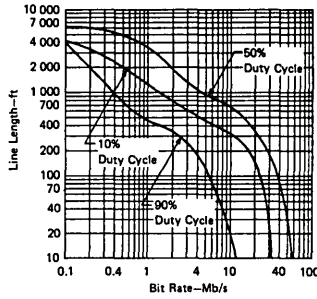

FIGURE 32

DRIVER . . . . .SN75123  
RECEIVER SN75125, SN75127

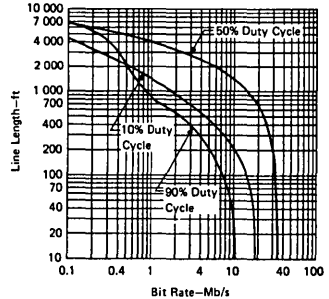
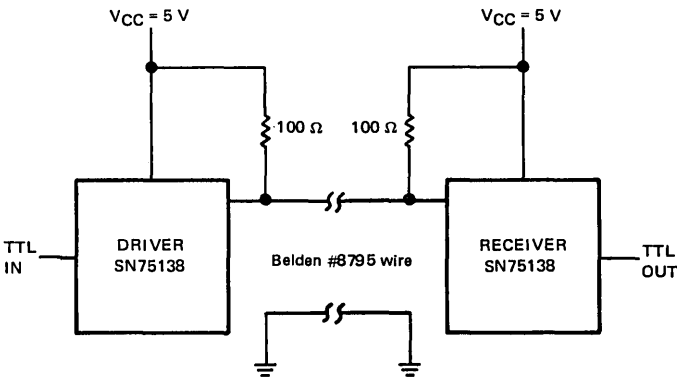

FIGURE 33

5



MEASUREMENT INFORMATION FOR FIGURE 34

DRIVER . . . . .SN75138  
RECEIVER . . . . .SN75138

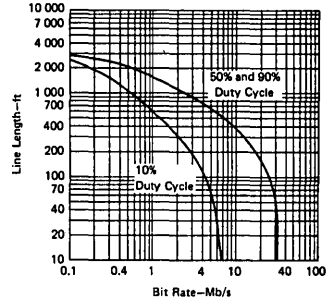
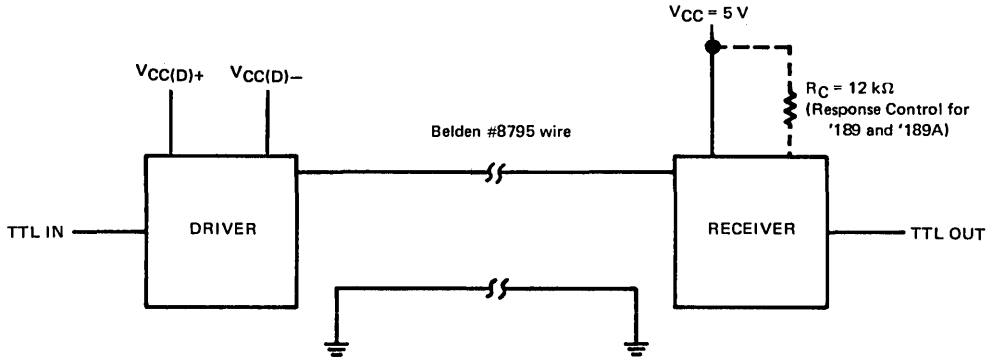

FIGURE 34

# LINE CIRCUITS APPLICATION INFORMATION

## LINE LENGTH CAPABILITY vs BIT RATE



MEASUREMENT INFORMATION FOR FIGURES 35 thru 37

5

DRIVER . . . . . SN75188  
RECEIVER . . . . . SN75189

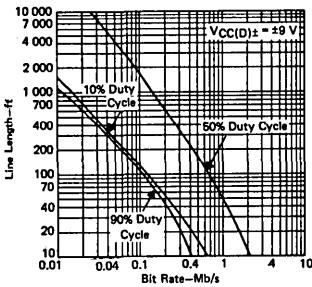

FIGURE 35

DRIVER . . . . . SN75188  
RECEIVER . . . . . SN75189A

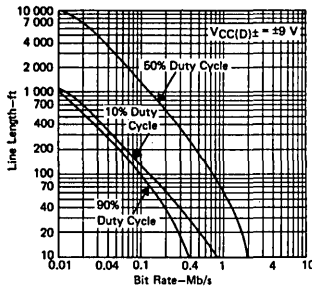

FIGURE 36

DRIVER . . . . . SN75150  
RECEIVER . . . . . SN75154

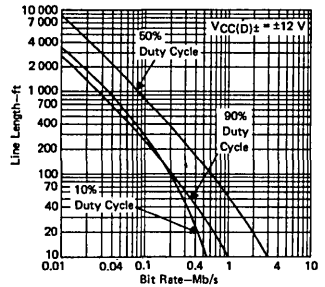
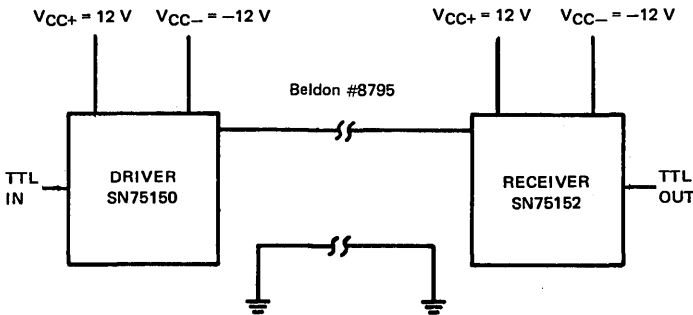

FIGURE 37



DRIVER . . . . . SN75150  
RECEIVER . . . . . SN75152

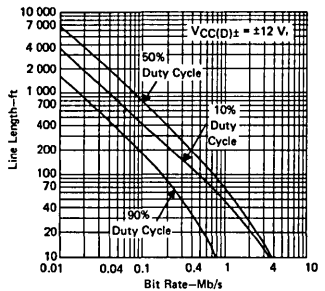
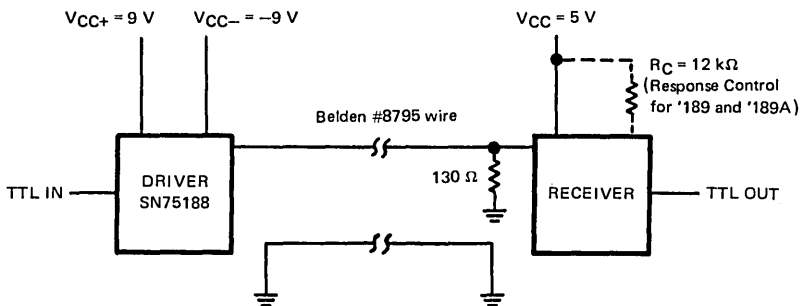

FIGURE 38

MEASUREMENT INFORMATION FOR FIGURE 38

# LINE CIRCUITS APPLICATION INFORMATION

## LINE LENGTH CAPABILITY vs BIT RATE



MEASUREMENT INFORMATION FOR FIGURES 39 AND 40

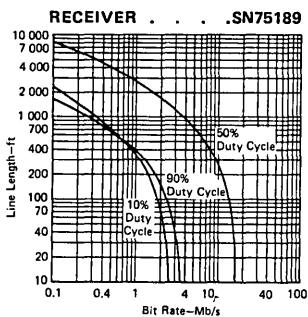

FIGURE 39

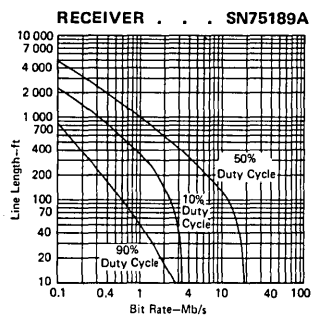
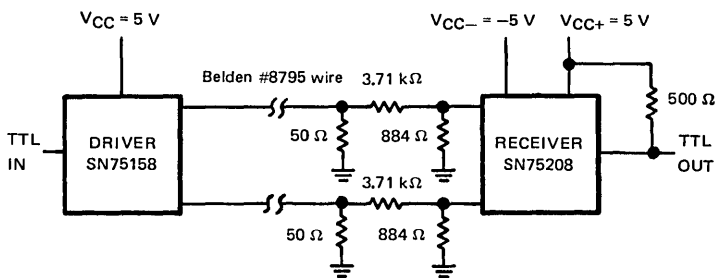

FIGURE 40



MEASUREMENT INFORMATION FOR FIGURE 41

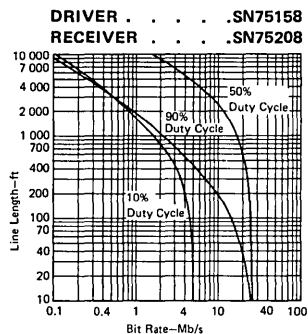
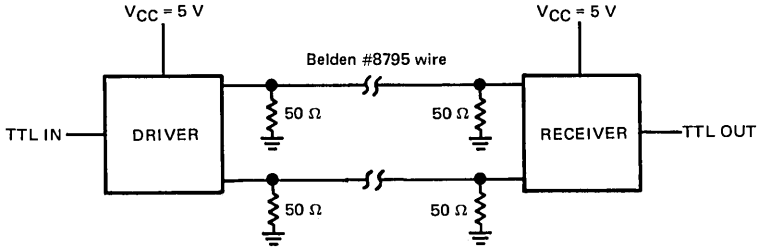

FIGURE 41

5

# LINE CIRCUITS APPLICATION INFORMATION

## LINE LENGTH CAPABILITY vs BIT RATE



MEASUREMENT INFORMATION FOR FIGURES 42 AND 43

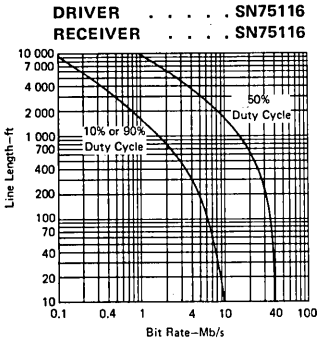

FIGURE 42

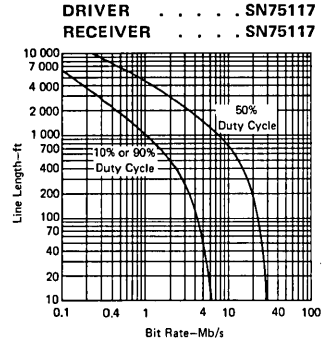
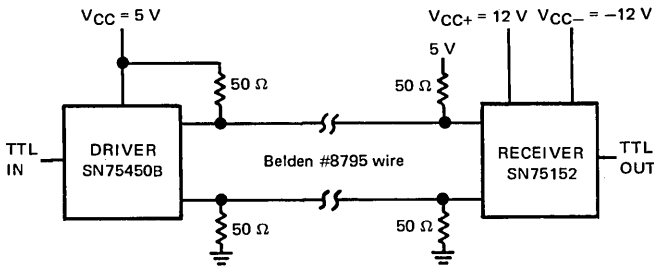

FIGURE 43



MEASUREMENT INFORMATION FOR FIGURE 44

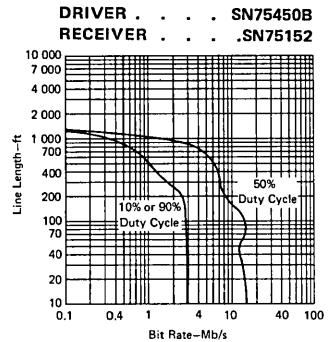

FIGURE 44

# Sense Amplifiers

## SENSE AMPLIFIERS

DESCRIPTION	THRESHOLD SENSITIVITY	COMMON-MODE RANGE	TYPE† OF OUTPUT	tpD‡ TYPICAL	DEVICE TYPE FOR TEMPERATURE RANGE		PACKAGE TYPE	UNITS PER PACKAGE	ADDITIONAL FEATURES	PAGE NO.
					-55°C to 125°C	0°C to 70°C				
CORE-MEMORY SENSE AMPLIFIERS	±4 mV	±2.5 V	R	35 ns	SN5520	SN7520	J J,N	1	<ul style="list-style-type: none"> <li>• Provides memory data register</li> <li>• Complementary outputs</li> </ul>	6-3
			O-C or R	30 ns	SN5522	SN7522	J J,N	1	<ul style="list-style-type: none"> <li>• Dual input channels</li> <li>• Single-ended output</li> </ul>	
			R	25 ns	SN5524	SN7524	J J,N	2	<ul style="list-style-type: none"> <li>• Independent strobes</li> </ul>	
			R	25 ns	SN5528	SN7528	J J,N	2	<ul style="list-style-type: none"> <li>• Independent strobes</li> <li>• Test points for strobe timing adjustment</li> </ul>	
			O-C	25 ns	SN55232	SN75232	J J,N	2	<ul style="list-style-type: none"> <li>• Independent strobes</li> <li>• Internally compensated reference amplifier</li> </ul>	
			R	25 ns	SN55234	SN75234	J J,N	2	<ul style="list-style-type: none"> <li>• Independent strobes</li> <li>• Internally compensated reference amplifier</li> </ul>	
			R	25 ns	SN55238	SN75238	J J,N	2	<ul style="list-style-type: none"> <li>• Independent strobes</li> <li>• Internally compensated reference amplifier</li> <li>• Test points for strobe timing adjustment</li> </ul>	
	±3 mV	±1.5 V	T-P	28 ns	SN55236	SN75236	W W	2	<ul style="list-style-type: none"> <li>• Built in data buffer and data register</li> <li>• Reference amplifier inherently stable</li> </ul>	See Note 1
MOS-TO-TTL CONVERTER ARRAY	500 μA		T-P	30 ns		SN75270	J,N	7	<ul style="list-style-type: none"> <li>• 7 single-ended noninverting drivers per package</li> <li>• Single 5-V supply</li> </ul>	6-59
MOS-MEMORY SENSE AMPLIFIERS	±25 mV	±3 V	T-P	17 ns	SN55107A	SN75107A	J J,N	2	<ul style="list-style-type: none"> <li>• Independent strobes</li> </ul>	5-49
	±25 mV	±3 V	O-C	19 ns	SN55108A	SN75108A	J J,N	2	<ul style="list-style-type: none"> <li>• Independent strobes</li> </ul>	
	±10 mV	±3 V	T-P	17 ns		SN75207	J,N	2	<ul style="list-style-type: none"> <li>• Independent strobes</li> </ul>	6-53
			O-C	19 ns		SN75208	J,N	2		
TMS 4062 I/O INTERFACE	±50 μA		R	25 ns		SN75370	J,N	2	<ul style="list-style-type: none"> <li>• Combined driver and sense amplifier</li> <li>• Read enable and write enable controls</li> </ul>	7-81

†T-P ≡ Totem Pole, O-C ≡ Open Collector, R ≡ Resistor Pull-Up

‡tpD = Propagation Delay Time

NOTE 1: For additional information, contact your nearest TI field sales office.



## HIGH-SPEED SENSE AMPLIFIERS FOR CONVERSION OF COINCIDENT-CURRENT MEMORY READOUT TO SATURATED DIGITAL-LOGIC LEVELS

### performance features

- High Speed and Fast Recovery Time
- Time and Amplitude Signal Discrimination
- Adjustable Input Threshold Voltage Levels
- Narrow Region of Threshold Voltage Uncertainty
- Multiple Differential-Input Preamplifiers
- High D-C Noise Margin . . . Typically One Volt
- Good Fan-Out Capability

### ease-of-design features

- Choice of Output Circuit Function
- TTL or DTL Drive Capability
- Standard Logic Supply Voltages
- Plug-in Configuration Ideal for Flow-Soldering Techniques
- Pins on 100-mil Grid Spacings for Industrial-Type Circuit Boards

### description

Series 5520/7520 monolithic sense amplifiers are designed for use with high-speed memory systems. These sense amplifiers detect bipolar differential-input signals from the memory and provide the interface circuitry between the memory and the logic section. Low-level pulses originating in the memory are transformed into logic levels compatible with standard transistor-transistor-logic (TTL) and diode-transistor-logic (DTL) circuits.

These sense amplifiers feature multiple differential-input preamplifiers and versatile gating and output circuits, permitting a significant reduction in the circuitry required to accomplish the sensing function. A unique circuit design provides inherent stability of the input threshold level over a wide range of power-supply voltage levels and temperature ranges. Independent strobing of each of the dual sense-input channels ensures maximum versatility and permits detection to occur when the signal-to-noise ratio is at a maximum. The gate and strobe inputs and the outputs are compatible with standard TTL and DTL digital logic circuits.

The SN5520 and SN7520 circuits may be used to perform the functions of a flip-flop or register that responds to the sense and strobe input conditions.

The SN5522 and SN7522 circuits feature a high-fan-out, single-ended, open-collector output stage. In addition, they may be used to expand the inputs to an SN5520 or SN7520 circuit, or to perform the wired-AND function.

The SN5524 and SN7524 circuits provide for independent, dual-channel sensing with separate outputs. SN55234 and SN75234 are similar but have inverted outputs and internal compensation. SN55232 and SN75232 are identical to the SN55234 and SN75234, respectively, except that their output gates each feature an open-collector output.

The SN5528 and SN7528 circuits are identical to the SN5524 and SN7524, respectively, except that the output of each preamplifier is available as a test point. SN55238 and SN75238 are similar to SN5528 and SN7528, respectively, but have inverted outputs and internal compensation.

Series 5520 sense amplifiers are available in the J ceramic dual-in-line package and are characterized for operation over the full military temperature range of  $-55^{\circ}\text{C}$  to  $125^{\circ}\text{C}$ . Series 7520 sense amplifiers are available in both the J (ceramic) and N (plastic) dual-in-line packages and are characterized for operation from  $0^{\circ}\text{C}$  to  $70^{\circ}\text{C}$ .

CONTENTS	PAGE
Design Characteristics, Circuit Operation, and Other General Information . . . . .	6-4
Maximum Ratings and Recommended Operating Conditions . . . . .	6-7
Definitive Specifications:	
Types SN5520, SN7520 . . . . .	6-8
Types SN5522, SN7522 . . . . .	6-10
Types SN5524, SN7524 . . . . .	6-12
Types SN5528, SN7528 . . . . .	6-14
Types SN55232, SN75232 . . . . .	6-16
Types SN55234, SN75234 . . . . .	6-18
Types SN55238, SN75238 . . . . .	6-20
D-C Test Circuits . . . . .	6-22
Switching Time Test Circuits and Voltage Waveforms . . . . .	6-37
Typical Characteristics . . . . .	6-46
Application Data . . . . .	6-49

# SERIES 5520/7520 SENSE AMPLIFIERS

## design characteristics

Series 5520/7520 sense amplifiers are completely d-c coupled. Previous designs have resulted in circuits in which the threshold level could not be closely controlled because they were highly sensitive to changes in the d-c levels throughout the amplifier. This was due primarily to the required tolerances on the absolute value of resistors and the resistor temperature coefficients. The "matched-amplifier" design of Series 5520/7520 circuits depends on resistor ratios rather than absolute values. In this design, excellent stability of the threshold level can be maintained despite component variations and changes in bias levels. The capability of multiple-input amplifiers increases the versatility of the design.

The basic circuit is used to implement several sense-amplifier designs. Additional logic circuitry is added to the strobe-gate output to provide versatile sensing functions. The outputs of two or more input amplifiers can be combined to implement multiple-input amplifiers, a function not previously available in integrated form. The d-c coupled design eliminates many of the problems associated with overload recovery time and threshold shift (with high input repetition rates) usually encountered in sense amplifier designs that use reactive coupling components.

## circuit operation

The basic Series 5520/7520 sense amplifier strobe and threshold circuit is shown in Figure A. The design uses a "matched-amplifier" concept that takes advantage of the inherent excellent component matching and thermal tracking characteristics of monolithic integrated circuits. A reference amplifier is used to generate the collector reference voltage that is distributed to the input amplifiers. Application of an external reference voltage,  $V_{ref}$ , establishes the input-amplifier threshold voltage level,  $V_T$ . The design is such that there is 1:1 correspondence between the applied reference voltage,  $V_{ref}$ , and the nominal threshold voltage level,  $V_T$ . The reference and input amplifiers use identical circuit configurations; therefore, changes in bias levels introduced into the input amplifier through changes in temperature or power-supply voltage levels are compensated by similar changes in the reference amplifier.

The collector reference voltage, supplied by the reference amplifier, can be used to control the threshold-voltage level of more than one input amplifier, thereby establishing equal threshold levels to all of the input sense channels simultaneously.

6

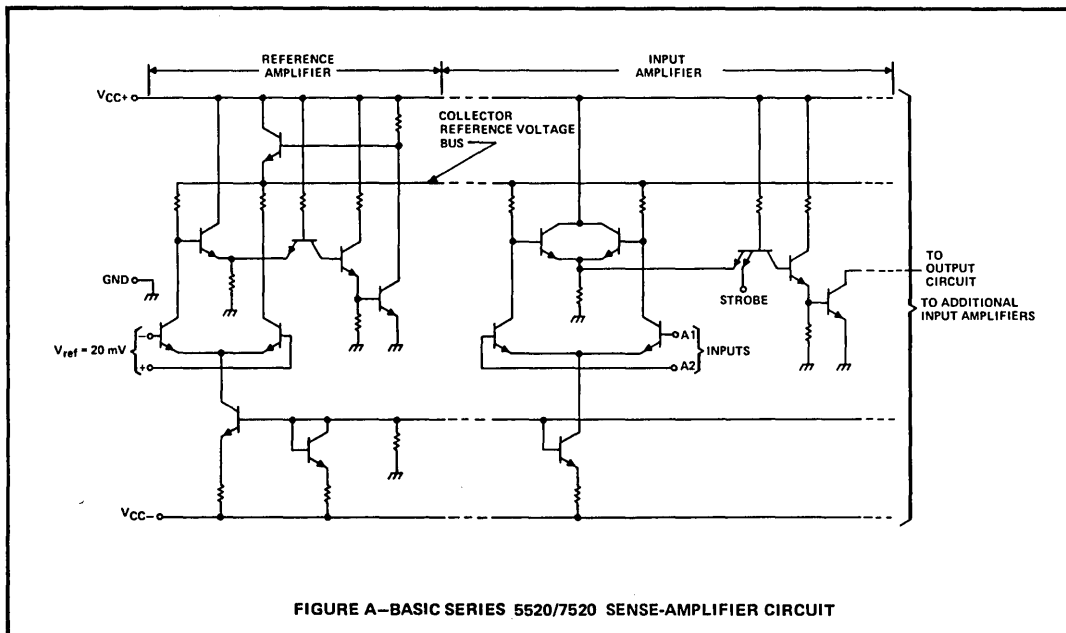

FIGURE A—BASIC SERIES 5520/7520 SENSE-AMPLIFIER CIRCUIT

# SERIES 5520/7520 SENSE AMPLIFIERS

## circuit operation (continued)

The second stage of the input amplifier is a TTL gate. This gate provides the threshold action for the input sense channel and provides a convenient point in the circuit to accomplish the strobe function. The differential-input sense signal switches the output of the TTL gate only when the strobe input voltage is higher than the logic input threshold voltage. The strobe input, therefore, provides the sense amplifier with the capability of time discrimination, allowing the input signal to be detected when the signal-to-noise ratio is at a maximum.

The logic inputs (i.e., gate and strobe) of Series 5520/7520 sense amplifiers are designed to be compatible with Series 54/74 TTL digital integrated circuits. The multiple-emitter transistors are utilized to provide inherent switching-time advantages over other saturated-logic schemes. The same noise margin and logic threshold voltage as guaranteed for Series 54/74 are assured for each of the gate and strobe inputs. This is accomplished by testing each logic input under standard Series 54/74 test conditions, i.e., 2 volts for high-level input condition and 0.8 volt for low-level input conditions. Since the guaranteed minimum high-level output voltage is 2.4 volts and the guaranteed maximum low-level output voltage is 0.4 volt, a minimum noise margin of 0.4 volt is assured at each input.

## SN5520/SN7520 circuit

This circuit is a dual-channel sense amplifier with the preamplifiers connected to a common output stage and a complementary output stage. The output circuit is composed of two cascaded NAND gates, each with external gate inputs. External connection of the Z output and the G<sub>Y</sub> input results in a flip-flop

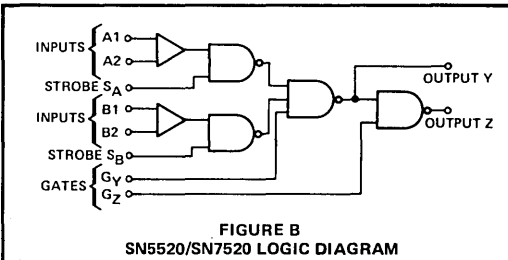

logic:  $Y = \bar{G}_Y + A \cdot S_A + B \cdot S_B$   
 $Z = \bar{G}_Z + Y$   
 $Z = \bar{G}_Z + G_Y (\bar{A} + \bar{S}_A) (\bar{B} + \bar{S}_B)$

or register that is set by signals at the differential-input terminals. Reset of the register is performed at the G<sub>Z</sub> input. Capacitive coupling from output Z to G<sub>Y</sub> results in output pulse stretching. With either connection, complementary output levels are available. The gate and strobe inputs and the outputs are compatible with standard TTL logic. The input function of SN5520/SN7520 can be expanded by connecting the Y output of SN5522/SN7522 to the G<sub>Y</sub> input of the circuit being expanded.

## SN5522/SN7522 circuit

This circuit is a dual-channel sense amplifier with the preamplifiers connected to a common output stage. The output circuit features an open-collector output that permits two or more of these outputs to be connected in the wire-AND configuration. Each package includes a load resistor that may be used as the output pull-up resistor. High sink-current capability is a feature of this design, and a separate ground terminal is used for the output circuitry. These devices can also be used as input expanders for the SN5520/SN7520 circuit.

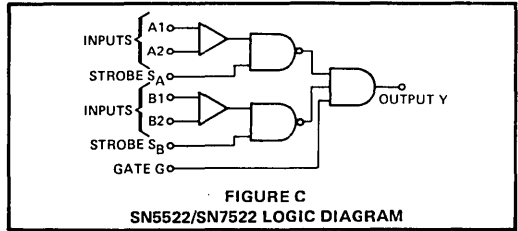

logic:  $Y = G (\bar{A} + \bar{S}_A) (\bar{B} + \bar{S}_B)$

## SN5524/SN7524 circuit

This circuit features two completely independent sense amplifiers in a single package. Each amplifier features high fan-out capability.

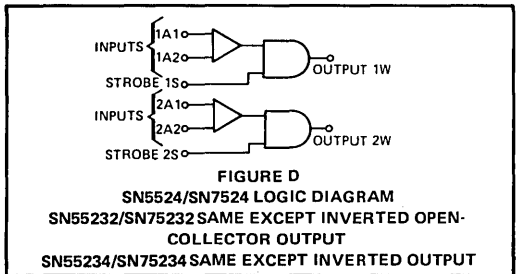

logic:  $W = AS$  for SN5524 and SN7524  
 $W = AS$  for SN55232, SN75232, SN55234, and SN75234

# SERIES 5520/7520 SENSE AMPLIFIERS

## SN5528/SN7528 circuit

This circuit features two separate single-preamplifier sense amplifiers in a single package. The output of each preamplifier is available as a test point. These test points can be used to observe the amplified core signal to facilitate accurate strobe timing. When using this device, care should be taken to avoid coupling the strobe signal or other stray signals to the test point. Excessive loading of the test point is also to be avoided. The result of either coupling or loading will be a change in the threshold voltage of the device. The output circuit of each channel features a simple TTL gate configuration with a high fan-out capability.

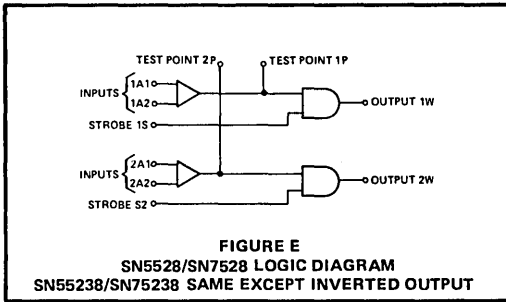

logic: W = AS for SN5528 and SN7528  
W =  $\overline{AS}$  for SN55238 and SN75238

## SN55232, SN75232, SN55234, SN75234, SN55238, and SN75238 circuits

The SN55234, SN75234, SN55238, and SN75238 dual sense amplifier circuits are the same as SN5524, SN7524, SN5528, and SN7528, respectively, except that an additional stage has been added to the output gate to provide an inverted output and internal compensation has been added. Compared to using a separate gate for inversion, not only is package count reduced, but less propagation delay is added. The need for an external roll-off capacitor has been eliminated. SN55232 and SN75232 are identical to the SN55234 and SN75234, respectively, except that their output gates each have an open-collector output. This permits two or more outputs to be connected in wire-AND configuration.

## reference voltage considerations

These sense amplifiers feature a variable-threshold voltage level with simultaneous adjustment of both sense channels or both sense amplifiers by a single reference voltage. The operating threshold voltage level of the input amplifiers is established by and is approximately equal to the applied reference input voltage,  $V_{ref}$ . These sense amplifiers are recommended for use in systems requiring threshold voltage levels of  $\pm 15$  to  $\pm 40$  mV.

A simple method of generating the reference voltage is the use of a resistor voltage divider from either the positive ( $V_{CC+}$ ) or negative ( $V_{CC-}$ ) voltage supplies. See Figure F. This type of voltage divider may be used to supply an individual reference amplifier or to supply a number of paralleled reference amplifiers. The bias current required at the reference amplifier input is low (nominally  $30 \mu A$ ); therefore, voltage dividers of this type may normally be operated with very low current requirements. In noisy environments, the use of a filter capacitor across the inputs is recommended. By locating the capacitor as close to the device terminals as possible, noise and stray signals will be presented common-mode to the reference amplifier and thus be rejected.

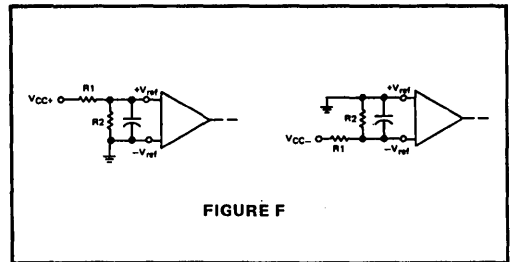

## input line layout considerations

Input sensitivity and device speed require adequate precautions in the routing of signal input and reference lines to prevent noise pickup. Bypassing of supply and reference inputs at the device with low-inductance disc ceramic capacitors and use of a good ground plane to separate strobe and output lines from sense and reference input lines are recommended.

# SERIES 5520/7520 SENSE AMPLIFIERS

## sense-input termination resistor considerations

Termination resistors are intentionally omitted from the sense-input terminals so the designer may select resistor values that will be compatible with the particular application. Matched termination resistors, ( $R_T$ , Figure G), normally in the range of  $25\ \Omega$  to  $200\ \Omega$  each, are required not only to terminate the sense line in a desired impedance but also to provide a d-c path for the sense-input bias currents. Careful matching of the resistor pairs should be observed or effective common-mode rejection will be reduced.

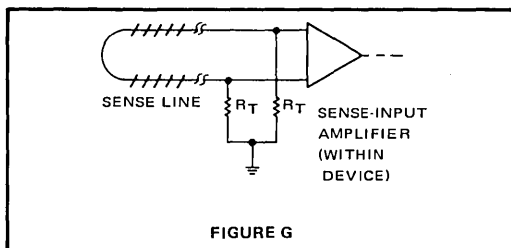

## output drive capability

The output circuits of these sense amplifiers feature the ability to sink or supply load current. This capability permits direct use with both TTL- and DTL-type loads. The open-collector output of the SN5522/SN7522 circuit may be connected to similar outputs to perform the wire-AND function. Load currents (out of the output terminal) are specified as negative values. Arrows on the d-c test circuit indicate the actual direction of current flow.

## logic input current requirements

Logic input current requirements are specified at worst-case power-supply conditions over the recommended operating free-air temperature range. The logic input currents are identical to those of, and compatible with, Series 54/74 TTL digital integrated circuits. Each logic input of the multiple-emitter input transistors requires no more than a 1.6-mA flow out of the input at a low logic level. Each input emitter requires current into the input when it is at a high-logic level. This current is  $40\ \mu\text{A}$  maximum. Currents into the input terminals are specified as positive values. Arrows on the d-c test circuits indicate the actual direction of current flow.

6

## absolute maximum ratings over operating free-air temperature range (unless otherwise noted)

Supply voltages (see Note 1)	
$V_{CC+}$	7 V
$V_{CC-}$	-7 V
Differential input voltage, $V_{ID}$ or $V_{ref}$	$\pm 5$ V
Voltage from any input to ground (see Note 2)	5.5 V
Off-state voltage applied to open-collector outputs	5.5 V
Operating free-air temperature range: SN55' circuits	-55°C to 125°C
SN75' circuits	0°C to 70°C
Storage temperature range	-65°C to 150°C
Lead temperature 1/16 inch from case for 60 seconds: J package	300°C
Lead temperature 1/16 inch from case for 10 seconds: N package	260°C

NOTES: 1. Voltage values, except differential voltages are with respect to network ground terminal.  
2. Strobe and gate input voltages must be zero or positive with respect to network ground terminal.

## recommended operating conditions

	MIN	NOM	MAX	UNIT
$V_{CC+}$	4.75	5	5.25	V
$V_{CC-}$	-4.75	-5	-5.25	V
$V_{ref}$	15		40	mV

# TYPES SN5520, SN7520

## DUAL-CHANNEL SENSE AMPLIFIERS WITH COMPLEMENTARY OUTPUTS

FUNCTION TABLE

INPUTS						OUTPUTS	
A	B	G <sub>Y</sub>	G <sub>Z</sub>	S <sub>A</sub>	S <sub>B</sub>	Y	Z
X	X	L	X	X	X	H	$\overline{G}_Z$
H	X	X	X	H	X	H	$\overline{G}_Z$
X	H	X	X	X	H	H	$\overline{G}_Z$
L	H	H	X	X	X	L	H
L	X	H	X	X	L	L	H
X	L	H	X	L	X	L	H
X	X	H	X	L	L	L	H
X	X	X	L	X	X	X	H

definition of logic levels

INPUT	H	L	X
A or B†	$V_{ID} \geq V_T \text{ max}$	$V_{ID} \leq V_T \text{ min}$	Irrelevant
Any G or S	$V_I \geq V_{IH} \text{ min}$	$V_I \leq V_{IL} \text{ max}$	Irrelevant

†A and B are differential voltages ( $V_{ID}$ ) between A1 and A2 or B1 and B2, respectively. For these circuits,  $V_{ID}$  is considered positive regardless of which terminal of each pair is positive with respect to the other.

JORN

DUAL-IN-LINE PACKAGE (TOP VIEW)

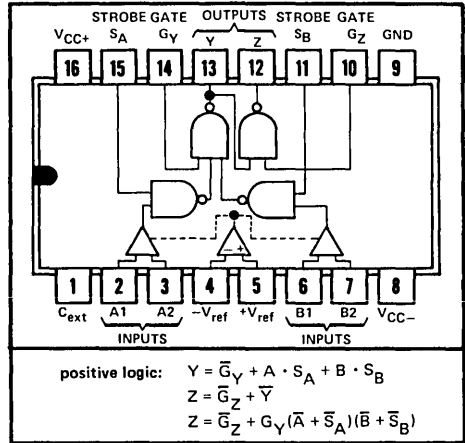

positive logic:  $Y = \overline{G}_Y + A \cdot S_A + B \cdot S_B$   
 $Z = \overline{G}_Z + \overline{Y}$   
 $Z = \overline{G}_Z + G_Y(\overline{A} + \overline{S}_A)(\overline{B} + \overline{S}_B)$

electrical characteristics over recommended operating free-air temperature-range,  $V_{CC+} = 5 \text{ V}$ ,  $V_{CC-} = -5 \text{ V}$  (unless otherwise noted)

PARAMETER	TEST FIGURE	TEST CONDITIONS	MIN	TYP‡	MAX	UNIT	
$V_T$ Differential-input threshold voltage	1	$V_{ref} = 15 \text{ mV}$	$T_A = 0^\circ\text{C to } 70^\circ\text{C}$	11	15	19	mV
			$T_A = -55^\circ\text{C to } 125^\circ\text{C}$ , SN5520 only	10	15	20	
		$V_{ref} = 40 \text{ mV}$	$T_A = 0^\circ\text{C to } 70^\circ\text{C}$	36	40	44	
			$T_A = -55^\circ\text{C to } 125^\circ\text{C}$ , SN5520 only	35	40	45	
$V_{ICF}$ Common-mode input firing voltage (see Note 3)	none	$V_{ref} = 40 \text{ mV}$ , $V_I(S) = V_{IH}$ Common-mode input pulse: $t_r \leq 15 \text{ ns}$ , $t_f \leq 15 \text{ ns}$ , $t_w = 50 \text{ ns}$		±2.5		V	
$I_{IB}$ Differential-input bias current	2	$V_{CC+} = 5.25 \text{ V}$ , $V_{CC-} = -5.25 \text{ V}$ , $V_{ID} = 0$	$T_A = -55^\circ\text{C to } 0^\circ\text{C}$ , SN5520 only			100	$\mu\text{A}$
			$T_A = 0^\circ\text{C to } 70^\circ\text{C}$			30	
		$T_A = 70^\circ\text{C to } 125^\circ\text{C}$ , SN5520 only				75	
$I_{IO}$ Differential-input offset current	2	$V_{CC+} = 5.25 \text{ V}$ , $V_{CC-} = -5.25 \text{ V}$ , $V_{ID} = 0$			0.5	$\mu\text{A}$	
$V_{IH}$ High-level input voltage (strobe and gate inputs)	3			2		V	
$V_{IL}$ Low-level input voltage (strobe and gate inputs)	3				0.8	V	
$V_{OH}$ High-level output voltage	3	$V_{CC+} = 4.75 \text{ V}$ , $V_{CC-} = -4.75 \text{ V}$ , $I_{OH} = -400 \mu\text{A}$	2.4		4	V	
$V_{OL}$ Low-level output voltage	3	$V_{CC+} = 4.75 \text{ V}$ , $V_{CC-} = -4.75 \text{ V}$ , $I_{OL} = 16 \text{ mA}$		0.25	0.4	V	
$I_{IH}$ High-level input current (strobe and gate inputs)	4	$V_{CC+} = 5.25 \text{ V}$ , $V_{CC-} = -5.25 \text{ V}$ , $V_{IH} = 2.4 \text{ V}$			40	$\mu\text{A}$	
$I_{IL}$ Low-level input current (strobe and gate inputs)	4	$V_{CC+} = 5.25 \text{ V}$ , $V_{CC-} = -5.25 \text{ V}$ , $V_{IL} = 0.4 \text{ V}$		-1	-1.6	mA	
$I_{OS(Y)}$ Short-circuit output current into Y	5	$V_{CC+} = 5.25 \text{ V}$ , $V_{CC-} = -5.25 \text{ V}$ , $T_A = 25^\circ\text{C}$	-3		-5	mA	
$I_{OS(Z)}$ Short-circuit output current into Z	5	$V_{CC+} = 5.25 \text{ V}$ , $V_{CC-} = -5.25 \text{ V}$ , $T_A = 25^\circ\text{C}$	-2.1		-3.5	mA	
$I_{CC+}$ Supply current from $V_{CC+}$	6	$V_{CC+} = 5.25 \text{ V}$ , $V_{CC-} = -5.25 \text{ V}$ , $T_A = 25^\circ\text{C}$		28	40	mA	
$I_{CC-}$ Supply current from $V_{CC-}$	6	$V_{CC+} = 5.25 \text{ V}$ , $V_{CC-} = -5.25 \text{ V}$ , $T_A = 25^\circ\text{C}$		-14	-20	mA	

‡All typical values are at  $V_{CC+} = 5 \text{ V}$ ,  $V_{CC-} = -5 \text{ V}$ ,  $T_A = 25^\circ\text{C}$ .

NOTE 3: Common-mode input firing voltage is the minimum common-mode voltage that will exceed the dynamic range of the input at the specified conditions and cause the logic output to switch. The common-mode input signal is applied when the strobe is high.

# TYPES SN5520, SN7520

## DUAL-CHANNEL SENSE AMPLIFIERS WITH COMPLEMENTARY OUTPUTS

switching characteristics,  $V_{CC+} = 5\text{ V}$ ,  $V_{CC-} = -5\text{ V}$ ,  $C_{ext} \geq 100\text{ pF}$ ,  $T_A = 25^\circ\text{C}$

PROPAGATION DELAY TIMES			TEST FIGURE	TEST CONDITIONS	MIN	TYP	MAX	UNIT
SYMBOL	FROM INPUT	TO OUTPUT						
$t_{PLH}(DY)$	A1-A2 OR B1-B2	Y	28	$C_L = 15\text{ pF}$ , $R_L = 288\ \Omega$		25	40	ns
$t_{PHL}(DY)$						20		
$t_{PLH}(DZ)$	A1-A2 OR B1-B2	Z	28	$C_L = 15\text{ pF}$ , $R_L = 288\ \Omega$		30		ns
$t_{PHL}(DZ)$						35	55	
$t_{PLH}(SY)$	STROBE A OR B	Y	28	$C_L = 15\text{ pF}$ , $R_L = 288\ \Omega$		15	30	ns
$t_{PHL}(SY)$						20		
$t_{PLH}(SZ)$	STROBE A OR B	Z	28	$C_L = 15\text{ pF}$ , $R_L = 288\ \Omega$		30		ns
$t_{PHL}(SZ)$						35	55	
$t_{PLH}(GY, Y)$	GATE $G_Y$	Y	29	$C_L = 15\text{ pF}$ , $R_L = 288\ \Omega$		15	25	ns
$t_{PHL}(GY, Y)$						10		
$t_{PLH}(GY, Z)$	GATE $G_Y$	Z	29	$C_L = 15\text{ pF}$ , $R_L = 288\ \Omega$		15		ns
$t_{PHL}(GY, Z)$						20	30	
$t_{PLH}(GZ, Z)$	GATE $G_Z$	Z	30	$C_L = 15\text{ pF}$ , $R_L = 288\ \Omega$		15		ns
$t_{PHL}(GZ, Z)$						10	20	

typical recovery and cycle times,  $V_{CC+} = 5\text{ V}$ ,  $V_{CC-} = -5\text{ V}$ ,  $C_{ext} \geq 100\text{ pF}$ ,  $T_A = 25^\circ\text{C}$

PARAMETER	TEST CONDITIONS	MIN	TYP	MAX	UNIT
$t_{orD}$	Differential-input overload recovery time (see Note 4)		20		ns
$t_{orC}$	Common-mode-input overload recovery time (see Note 5)		20		ns
$t_{cyc}(\text{min})$	Minimum cycle time		200		ns

- NOTES: 4. Differential-input overload recovery time is the time necessary for the device to recover from the specified differential-input-overload signal prior to the strobe-enable signal.  
5. Common-mode-input overload recovery time is the time necessary for the device to recover from the specified common-mode-input overload signal prior to the strobe-enable signal.

### schematic

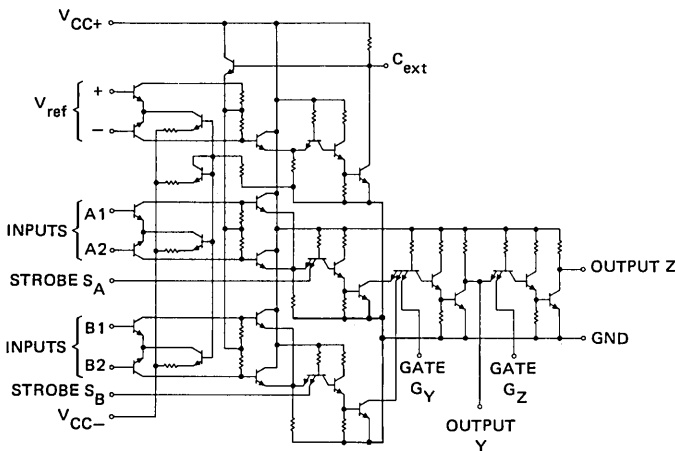

# TYPES SN5522, SN7522

## DUAL-CHANNEL SENSE AMPLIFIERS

FUNCTION TABLE

INPUTS					OUTPUT
A	B	G	S <sub>A</sub>	S <sub>B</sub>	Y
L	L	H	X	X	H
L	X	H	X	L	H
X	L	H	L	X	H
X	X	H	L	L	H
X	X	L	X	X	L
H	X	X	H	X	L
X	H	X	X	H	L

definition of logic levels

INPUT	H	L	X
A or B†	$V_{ID} > V_T \text{ max}$	$V_{ID} < V_T \text{ min}$	Irrelevant
Any G or S	$V_I > V_{IH} \text{ min}$	$V_I < V_{IL} \text{ max}$	Irrelevant

†A and B are differential voltages ( $V_{ID}$ ) between A1 and A2 or B1 and B2, respectively. For these circuits,  $V_{ID}$  is considered positive regardless of which terminal of each pair is positive with respect to the other.

electrical characteristics over recommended operating free-air temperature range,  $V_{CC+} = 5 \text{ V}$ ,  $V_{CC-} = -5 \text{ V}$  (unless otherwise noted)

PARAMETER	TEST FIGURE	TEST CONDITIONS		MIN	TYP‡	MAX	UNIT
$V_T$ Differential-input threshold voltage	7	$V_{ref} = 15 \text{ mV}$	$T_A = 0^\circ\text{C to } 70^\circ\text{C}$	11	15	19	mV
			$T_A = -55^\circ\text{C to } 125^\circ\text{C}$ , SN5522 only	10	15	20	
		$V_{ref} = 40 \text{ mV}$	$T_A = 0^\circ\text{C to } 70^\circ\text{C}$	36	40	44	
$V_{ICF}$ Common-mode input firing voltage (see Note 3)	none	$V_{ref} = 40 \text{ mV}$ , $t_r < 15 \text{ ns}$ , $t_f < 15 \text{ ns}$ , $t_w = 50 \text{ ns}$	$V_I(S) = V_{IH}$ Common-mode input pulse:	±2.5			V
			$T_A = -55^\circ\text{C to } 0^\circ\text{C}$ , SN5522 only			100	
$I_{IB}$ Differential-input bias current	2	$V_{CC+} = 5.25 \text{ V}$ , $V_{CC-} = -5.25 \text{ V}$ , $V_{ID} = 0$	$T_A = 0^\circ\text{C to } 70^\circ\text{C}$	30		75	µA
			$T_A = 70^\circ\text{C to } 125^\circ\text{C}$ , SN5522 only			75	
$I_{IO}$ Differential-input offset current	2	$V_{CC+} = 5.25 \text{ V}$ , $V_{CC-} = -5.25 \text{ V}$ , $V_{ID} = 0$		0.5			µA
$V_{IH}$ High-level input voltage (strobe and gate inputs)	8			2			V
$V_{IL}$ Low-level input voltage (strobe and gate inputs)	8					0.8	V
$V_{OH}$ High-level output voltage	8	$V_{CC+} = 4.75 \text{ V}$ , $V_{CC-} = -4.75 \text{ V}$ , $I_{OH} = -400 \mu\text{A}$		2.4	4		V
$V_{OL}$ Low-level output voltage	8	$V_{CC+} = 4.75 \text{ V}$ , $V_{CC-} = -4.75 \text{ V}$ , $I_{OL} = 16 \text{ mA}$		0.25		0.4	V
$I_{IH}$ High-level input current (strobe and gate inputs)	9	$V_{CC+} = 5.25 \text{ V}$ , $V_{CC-} = -5.25 \text{ V}$ , $V_{IH} = 5.25 \text{ V}$	$V_{IH} = 2.4 \text{ V}$	40			µA
				1			
$I_{IL}$ Low-level input current (strobe and gate inputs)	9	$V_{CC+} = 5.25 \text{ V}$ , $V_{CC-} = -5.25 \text{ V}$ , $V_{IL} = 0.4 \text{ V}$		-1		-1.6	mA
$I_{OH}$ High-level output current	10	$V_{CC+} = 4.75 \text{ V}$ , $V_{CC-} = -4.75 \text{ V}$ , $V_O = 5.25 \text{ V}$		250			µA
$I_{OS}$ Short-circuit output current	11	$V_{CC+} = 5.25 \text{ V}$ , $V_{CC-} = -5.25 \text{ V}$ , $T_A = 25^\circ\text{C}$		-2.1		-3.5	mA
$I_{CC+}$ Supply current from $V_{CC+}$	6	$V_{CC+} = 5.25 \text{ V}$ , $V_{CC-} = -5.25 \text{ V}$ , $T_A = 25^\circ\text{C}$		27		40	mA
$I_{CC-}$ Supply current from $V_{CC-}$	6	$V_{CC+} = 5.25 \text{ V}$ , $V_{CC-} = -5.25 \text{ V}$ , $T_A = 25^\circ\text{C}$		-15		-20	mA

‡All typical values are at  $V_{CC+} = 5 \text{ V}$ ,  $V_{CC-} = -5 \text{ V}$ ,  $T_A = 25^\circ\text{C}$ .

NOTE 3: Common-mode input firing voltage is the minimum common-mode voltage that will exceed the dynamic range of the input at the specified conditions and cause the logic output to switch. The common-mode input signal is applied when the strobe is high.

JORN  
DUAL-IN-LINE PACKAGE (TOP VIEW)

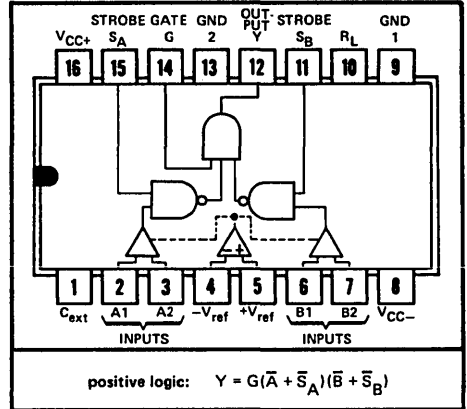



# TYPES SN5522, SN7522 DUAL-CHANNEL SENSE AMPLIFIERS

switching characteristics,  $V_{CC+} = 5\text{ V}$ ,  $V_{CC-} = -5\text{ V}$ ,  $C_{ext} \geq 100\text{ pF}$ ,  $T_A = 25^\circ\text{C}$

PROPAGATION DELAY TIMES			TEST FIGURE	TEST CONDITIONS	MIN	TYP	MAX	UNIT
SYMBOL	FROM INPUT	TO OUTPUT						
$t_{PLH(D)}$	A1-A2 OR B1-B2	Y	31	$C_L = 15\text{ pF}$ , $R_L = 288\ \Omega$	20	30	45	ns
$t_{PHL(D)}$								
$t_{PLH(S)}$	STROBE A OR B	Y	31	$C_L = 15\text{ pF}$ , $R_L = 288\ \Omega$	20	20	40	ns
$t_{PHL(S)}$								
$t_{PLH(G)}$	GATE	Y	32	$C_L = 15\text{ pF}$ , $R_L = 288\ \Omega$	10	15	25	ns
$t_{PHL(G)}$								

typical recovery and cycle times,  $V_{CC+} = 5\text{ V}$ ,  $V_{CC-} = -5\text{ V}$ ,  $C_{ext} \geq 100\text{ pF}$ ,  $T_A = 25^\circ\text{C}$

PARAMETER	TEST CONDITIONS	MIN	TYP	MAX	UNIT
$t_{orD}$	Differential-input overload recovery time (see Note 4) <i>Differential Input Pulse:</i> $V_{ID} = 2\text{ V}$ , $t_r = t_f = 20\text{ ns}$		20		ns
$t_{orC}$	Common-mode-input overload recovery time (see Note 5) <i>Common-Mode Input Pulse:</i> $V_{IC} = \pm 2\text{ V}$ , $t_r = t_f = 20\text{ ns}$		20		ns
$t_{cyc(min)}$	Minimum cycle time		200		ns

- NOTES: 4. Differential-input overload recovery time is the time necessary for the device to recover from the specified differential input-overload signal prior to the strobe-enable signal.  
5. Common-mode-input overload recovery time is the time necessary for the device to recover from the specified common-mode-input overload signal prior to the strobe-enable signal.

schematic

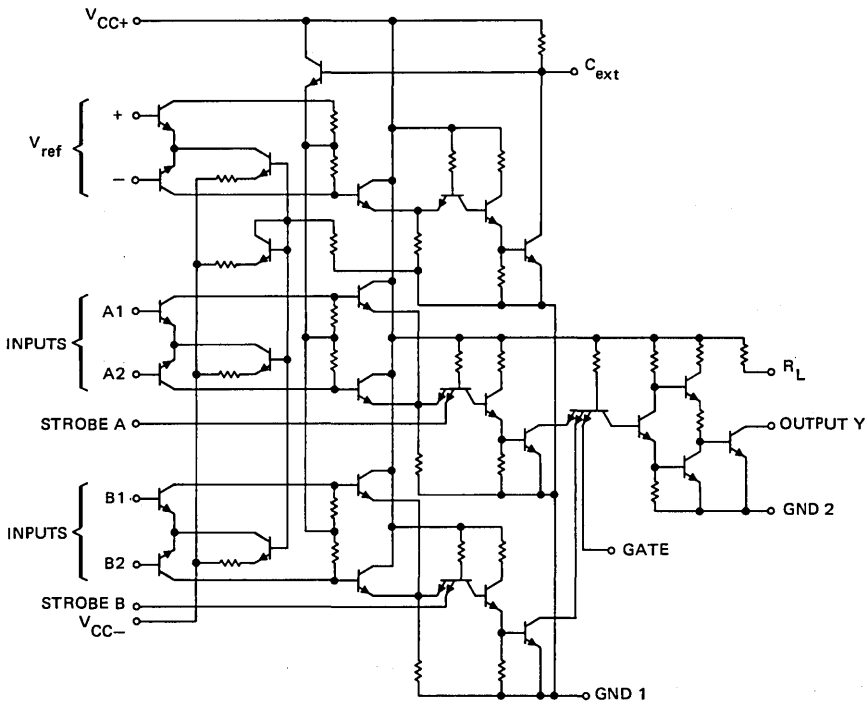

6

# TYPES SN5524, SN7524 DUAL SENSE AMPLIFIERS

FUNCTION TABLE

INPUTS		OUTPUT
A	S	W
H	H	H
L	X	L
X	L	L

definition of logic levels

INPUT	H	L	X
A†	$V_{ID} \geq V_T \text{ max}$	$V_{ID} \leq V_T \text{ min}$	Irrelevant
S	$V_I \geq V_{IH} \text{ min}$	$V_I \leq V_{IL} \text{ max}$	Irrelevant

†A is a differential voltage ( $V_{ID}$ ) between A1 and A2. For these circuits,  $V_{ID}$  is considered positive regardless of which terminal is positive with respect to the other.

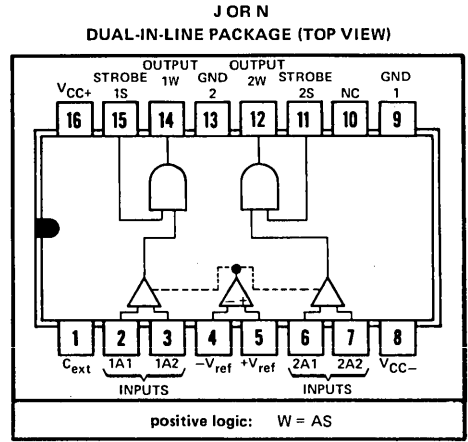

electrical characteristics over recommended operating free-air temperature range,  $V_{CC+} = 5 \text{ V}$ ,  $V_{CC-} = -5 \text{ V}$  (unless otherwise noted)

PARAMETER	TEST FIGURE	TEST CONDITIONS			MIN	TYP‡	MAX	UNIT
$V_T$ Differential-input threshold voltage	12	$V_{ref} = 15 \text{ mV}$	$T_A = 0^\circ\text{C to } 70^\circ\text{C}$	11	15	19	mV	
			$T_A = -55^\circ\text{C to } 125^\circ\text{C}$ , SN5524 only	10	15	20		
		$V_{ref} = 40 \text{ mV}$	$T_A = 0^\circ\text{C to } 70^\circ\text{C}$	36	40	44		
			$T_A = -55^\circ\text{C to } 125^\circ\text{C}$ , SN5524 only	35	40	45		
$V_{ICF}$ Common-mode input firing voltage (see Note 3)	none	$V_{ref} = 40 \text{ mV}$ , $V_I(S) = V_{IH}$ Common-mode input pulse: $t_r \leq 15 \text{ ns}$ , $t_f \leq 15 \text{ ns}$ , $t_w = 50 \text{ ns}$			±2.5		V	
$I_{IB}$ Differential-input bias current	2	$V_{CC+} = 5.25 \text{ V}$ , $V_{CC-} = -5.25 \text{ V}$ , $V_{ID} = 0$	$T_A = -55^\circ\text{C to } 0^\circ\text{C}$ , SN5524 only	100		μA		
			$T_A = 0^\circ\text{C to } 70^\circ\text{C}$	30 75				
			$T_A = 70^\circ\text{C to } 125^\circ\text{C}$ , SN5524 only	75				
$I_{IO}$ Differential-input offset current	2	$V_{CC+} = 5.25 \text{ V}$ , $V_{CC-} = -5.25 \text{ V}$ , $V_{ID} = 0$	0.5		μA			
$V_{IH}$ High-level input voltage (strobe inputs)	13				2	V		
$V_{IL}$ Low-level input voltage (strobe inputs)	13				0.8	V		
$V_{OH}$ High-level output voltage	13	$V_{CC+} = 4.75 \text{ V}$ , $V_{CC-} = -4.75 \text{ V}$ , $I_{OH} = -400 \mu\text{A}$	2.4	4	V			
$V_{OL}$ Low-level output voltage	13	$V_{CC+} = 4.75 \text{ V}$ , $V_{CC-} = -4.75 \text{ V}$ , $I_{OL} = 16 \text{ mA}$	0.25	0.4	V			
$I_{IH}$ High-level input current (strobe inputs)	14	$V_{CC+} = 5.25 \text{ V}$ , $V_{CC-} = -5.25 \text{ V}$ , $V_{IH} = 2.4 \text{ V}$	40		μA			
		$V_{CC+} = 5.25 \text{ V}$ , $V_{CC-} = -5.25 \text{ V}$ , $V_{IH} = 5.25 \text{ V}$	1		mA			
$I_{IL}$ Low-level input current (strobe inputs)	14	$V_{CC+} = 5.25 \text{ V}$ , $V_{CC-} = -5.25 \text{ V}$ , $V_{IL} = 0.4 \text{ V}$	-1	-1.6	mA			
$I_{OS}$ Short-circuit output current	15	$V_{CC+} = 5.25 \text{ V}$ , $V_{CC-} = -5.25 \text{ V}$ , $T_A = 25^\circ\text{C}$	-2.1	-3.5	mA			
$I_{CC+}$ Supply current from $V_{CC+}$	6	$V_{CC+} = 5.25 \text{ V}$ , $V_{CC-} = -5.25 \text{ V}$ , $T_A = 25^\circ\text{C}$	25	40	mA			
$I_{CC-}$ Supply current from $V_{CC-}$	6	$V_{CC+} = 5.25 \text{ V}$ , $V_{CC-} = -5.25 \text{ V}$ , $T_A = 25^\circ\text{C}$	-15	-20	mA			

‡All typical values are at  $V_{CC+} = 5 \text{ V}$ ,  $V_{CC-} = -5 \text{ V}$ ,  $T_A = 25^\circ\text{C}$ .

NOTE 3: Common-mode input firing voltage is the minimum common-mode voltage that will exceed the dynamic range of the input at the specified conditions and cause the logic output to switch. The common-mode input signal is applied when the strobe is high.

# TYPES SN5524, SN7524 DUAL SENSE AMPLIFIERS

switching characteristics,  $V_{CC+} = 5\text{ V}$ ,  $V_{CC-} = -5\text{ V}$ ,  $C_{ext} \geq 100\text{ pF}$ ,  $T_A = 25^\circ\text{C}$

PROPAGATION DELAY TIMES			TEST FIGURE	TEST CONDITIONS	MIN	TYP	MAX	UNIT
SYMBOL	FROM INPUT	TO OUTPUT						
$t_{PLH(D)}$	A1-A2	W	33	$C_L = 15\text{ pF}$ , $R_L = 288\ \Omega$		25	40	ns
$t_{PHL(D)}$								
$t_{PLH(S)}$	STROBE	W	33	$C_L = 15\text{ pF}$ , $R_L = 288\ \Omega$		15	30	ns
$t_{PHL(S)}$								

typical recovery and cycle times,  $V_{CC+} = 5\text{ V}$ ,  $V_{CC-} = -5\text{ V}$ ,  $C_{ext} \geq 100\text{ pF}$ ,  $T_A = 25^\circ\text{C}$

PARAMETER	TEST CONDITIONS	MIN	TYP	MAX	UNIT
$t_{orD}$	Differential-input overload recovery time (see Note 4) <i>Differential Input Pulse:</i> $V_{ID} = 2\text{ V}$ , $t_r = t_f = 20\text{ ns}$		20		ns
$t_{orC}$	Common-mode-input overload recovery time (see Note 5) <i>Common-Mode Input Pulse:</i> $V_{IC} = \pm 2\text{ V}$ , $t_r = t_f = 20\text{ ns}$		20		ns
$t_{cyc(min)}$	Minimum cycle time		200		ns

NOTES: 4. Differential-input overload recovery time is the time necessary for the device to recover from the specified differential-input-overload signal prior to the strobe-enable signal.

5. Common-mode-input overload recovery time is the time necessary for the device to recover from the specified common-mode-input overload signal prior to the strobe-enable signal.

schematic

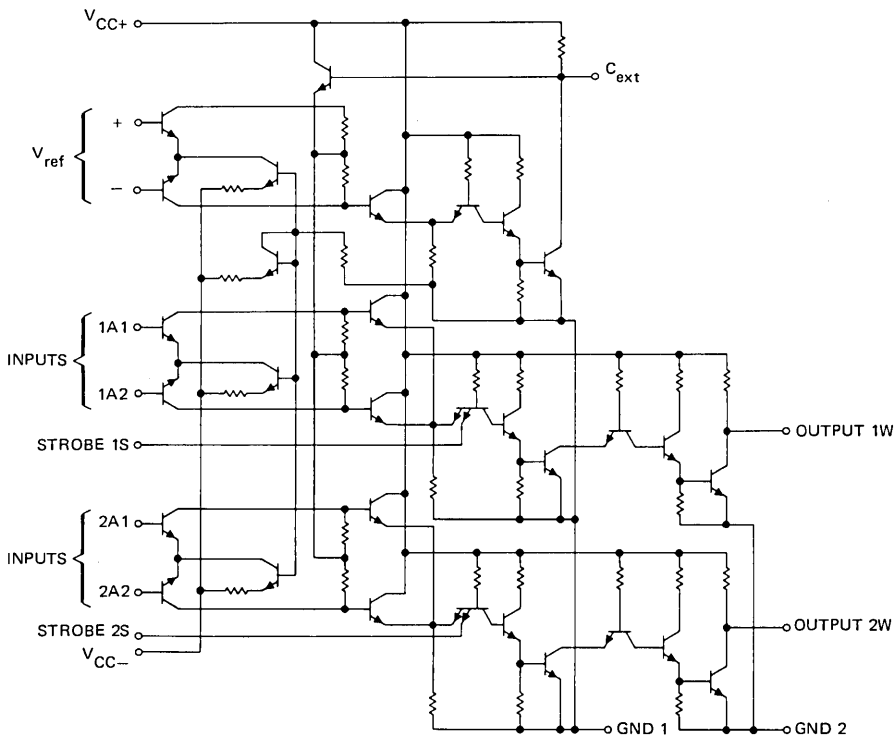

# TYPES SN5528, SN7528

## DUAL SENSE AMPLIFIERS WITH PREAMPLIFIER TEST POINTS

FUNCTION TABLE

INPUTS		OUTPUT
A	S	W
H	H	H
L	X	L
X	L	L

### definition of logic levels

INPUT	H	L	X
A†	$V_{ID} \geq V_T \text{ max}$	$V_{ID} \leq V_T \text{ min}$	Irrelevant
S	$V_I \geq V_{IH} \text{ min}$	$V_I \leq V_{IL} \text{ max}$	Irrelevant

† A is a differential voltage ( $V_{ID}$ ) between A1 and A2. For these circuits,  $V_{ID}$  is considered positive regardless of which terminal is positive with respect to the other.

J OR N  
DUAL-IN-LINE PACKAGE (TOP VIEW)

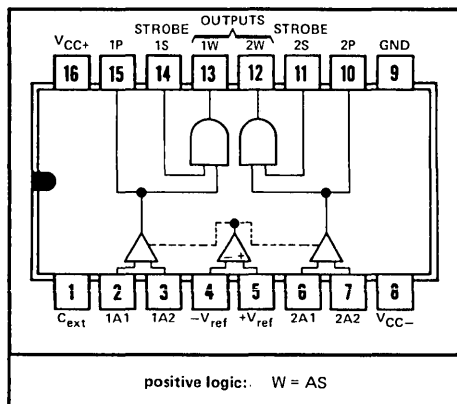

electrical characteristics over recommended operating free-air temperature range,  $V_{CC+} = 5 \text{ V}$ ,  $V_{CC-} = -5 \text{ V}$  (unless otherwise noted)

PARAMETER	TEST FIGURE	TEST CONDITIONS			MIN	TYP‡	MAX	UNIT
		$V_{ref} = 15 \text{ mV}$	$T_A = 0^\circ\text{C to } 70^\circ\text{C}$	$T_A = -55^\circ\text{C to } 125^\circ\text{C, SN5528 only}$				
$V_T$ Differential-input threshold voltage	16	$V_{ref} = 15 \text{ mV}$	$T_A = 0^\circ\text{C to } 70^\circ\text{C}$	11	15	19	mV	
			$T_A = -55^\circ\text{C to } 125^\circ\text{C, SN5528 only}$	10	15	20		
		$V_{ref} = 40 \text{ mV}$	$T_A = 0^\circ\text{C to } 70^\circ\text{C}$	36	40	44		
			$T_A = -55^\circ\text{C to } 125^\circ\text{C, SN5528 only}$	35	40	45		
$V_{ICF}$ Common-mode input firing voltage (see Note 3)	none	$V_{ref} = 40 \text{ mV}$ , $V_I(S) = V_{IH}$ Common-mode input pulse: $t_r \leq 15 \text{ ns}$ , $t_f \leq 15 \text{ ns}$ , $t_w = 50 \text{ ns}$		$\pm 2.5$			V	
$I_{IB}$ Differential-input bias current	2	$V_{CC+} = 5.25 \text{ V}$ , $V_{CC-} = -5.25 \text{ V}$ , $V_{ID} = 0$	$T_A = -55^\circ\text{C to } 0^\circ\text{C}$ , SN5528 only			100	$\mu\text{A}$	
			$T_A = 0^\circ\text{C to } 70^\circ\text{C}$			30		75
			$T_A = 70^\circ\text{C to } 125^\circ\text{C}$ , SN5528 only					75
$I_{IO}$ Differential-input offset current	2	$V_{CC+} = 5.25 \text{ V}$ , $V_{CC-} = -5.25 \text{ V}$ , $V_{ID} = 0$				0.5	$\mu\text{A}$	
$V_{IH}$ High-level input voltage (strobe inputs)	17				2		V	
$V_{IL}$ Low-level input voltage (strobe inputs)	17					0.8	V	
$V_{OH}$ High-level output voltage	17	$V_{CC+} = 4.75 \text{ V}$ , $V_{CC-} = -4.75 \text{ V}$ , $I_{OH} = -400 \mu\text{A}$			2.4	4	V	
$V_{OL}$ Low-level output voltage	17	$V_{CC+} = 4.75 \text{ V}$ , $V_{CC-} = -4.75 \text{ V}$ , $I_{OL} = 16 \text{ mA}$			0.25	0.4	V	
$I_{IH}$ High-level input current (strobe inputs)	18	$V_{CC+} = 5.25 \text{ V}$ , $V_{CC-} = -5.25 \text{ V}$ , $V_{IH} = 2.4 \text{ V}$				40	$\mu\text{A}$	
		$V_{CC+} = 5.25 \text{ V}$ , $V_{CC-} = -5.25 \text{ V}$ , $V_{IH} = 5.25 \text{ V}$				1		mA
$I_{IL}$ Low-level input current (strobe inputs)	18	$V_{CC+} = 5.25 \text{ V}$ , $V_{CC-} = -5.25 \text{ V}$ , $V_{IL} = 0.4 \text{ V}$				-1	-1.6	mA
$I_{OS}$ Short-circuit output current	19	$V_{CC+} = 5.25 \text{ V}$ , $V_{CC-} = -5.25 \text{ V}$ , $T_A = 25^\circ\text{C}$			-2.1	-3.5	mA	
$I_{CC+}$ Supply current from $V_{CC+}$	6	$V_{CC+} = 5.25 \text{ V}$ , $V_{CC-} = -5.25 \text{ V}$ , $T_A = 25^\circ\text{C}$				25	40	mA
$I_{CC-}$ Supply current from $V_{CC-}$	6	$V_{CC+} = 5.25 \text{ V}$ , $V_{CC-} = -5.25 \text{ V}$ , $T_A = 25^\circ\text{C}$				-15	-20	mA

‡ All typical values are at  $V_{CC+} = 5 \text{ V}$ ,  $V_{CC-} = -5 \text{ V}$ ,  $T_A = 25^\circ\text{C}$ .

NOTE 3: Common-mode input firing voltage is the minimum common-mode voltage that will exceed the dynamic range of the input at the specified conditions and cause the logic output to switch. The common-mode input signal is applied when the strobe is high.

# TYPES SN5528, SN7528 DUAL SENSE AMPLIFIERS WITH PREAMPLIFIER TEST POINTS

switching characteristics,  $V_{CC+} = 5\text{ V}$ ,  $V_{CC-} = -5\text{ V}$ ,  $T_A = 25^\circ\text{C}$

PROPAGATION DELAY TIMES			TEST FIGURE	TEST CONDITIONS	MIN	TYP	MAX	UNIT		
SYMBOL	FROM INPUT	TO OUTPUT								
$t_{PLH(D)}$	A1-A2	W	34	$C_L = 15\text{ pF}$ , $R_L = 288\ \Omega$				25	40	ns
$t_{PHL(D)}$								20	ns	
$t_{PLH(S)}$	STROBE	W	34	$C_L = 15\text{ pF}$ , $R_L = 288\ \Omega$				15	30	ns
$t_{PHL(S)}$								20	ns	

typical recovery and cycle times,  $V_{CC+} = 5\text{ V}$ ,  $V_{CC-} = -5\text{ V}$ ,  $T_A = 25^\circ\text{C}$

PARAMETER	TEST CONDITIONS	MIN	TYP	MAX	UNIT
$t_{orD}$	Differential-input overload recovery time (see Note 4) <i>Differential Input Pulse:</i> $V_{ID} = 2\text{ V}$ , $t_f = 20\text{ ns}$		20		ns
$t_{orC}$	Common-mode-input overload recovery time (see Note 5) <i>Common-Mode Input Pulse:</i> $V_{IC} = \pm 2\text{ V}$ , $t_r = t_f = 20\text{ ns}$		20		ns
$t_{cyc(min)}$	Minimum cycle time		200		ns

- NOTES: 4. Differential-input overload recovery time is the time necessary for the device to recover from the specified differential-input overload signal prior to the strobe-enable signal.  
5. Common-mode-input overload recovery time is the time necessary for the device to recover from the specified common-mode-input overload signal prior to the strobe-enable signal.

schematic

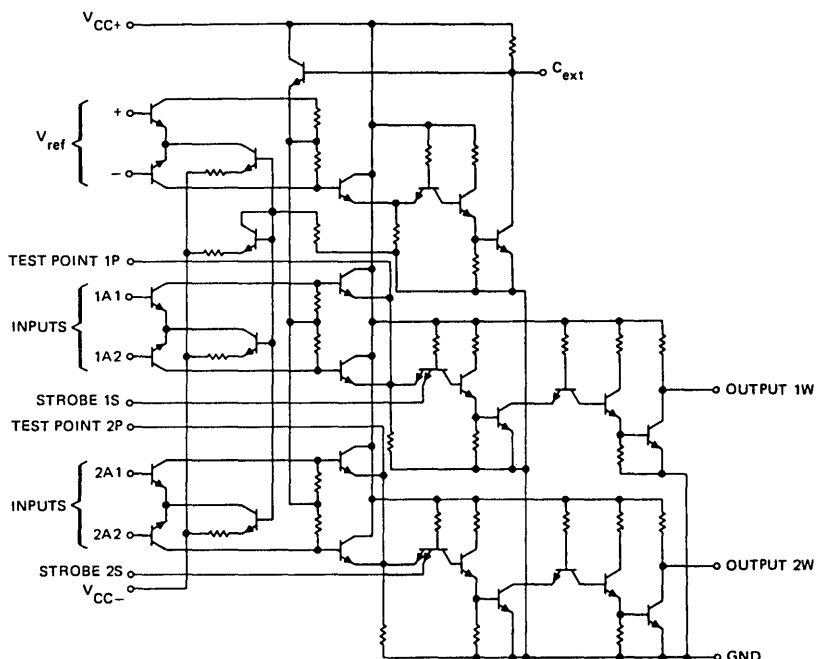

# TYPES SN55232, SN75232

## DUAL SENSE AMPLIFIERS

FUNCTION TABLE

INPUTS		OUTPUT
A	S	W
H	H	L
L	X	H
X	L	H

definition of logic levels

INPUT	H	L	X
A1	$V_{ID} \geq V_T \text{ max}$	$V_{ID} < V_T \text{ min}$	Irrelevant
S	$V_I \geq V_{IH} \text{ min}$	$V_I < V_{IL} \text{ max}$	Irrelevant

<sup>†</sup>A is a differential voltage ( $V_{ID}$ ) between A1 and A2. For these circuits,  $V_{ID}$  is considered positive regardless of which terminal is positive with respect to the other.

JOR N  
DUAL-IN-LINE PACKAGE (TOP VIEW)

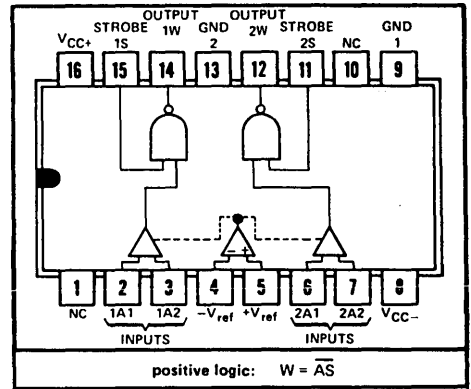

NC—No internal connection

electrical characteristics over recommended operating free-air temperature range,  $V_{CC+} = 5 \text{ V}$ ,  $V_{CC-} = -5 \text{ V}$  (unless otherwise noted)

PARAMETER	TEST FIGURE	TEST CONDITIONS	MIN	TYP <sup>‡</sup>	MAX	UNIT	
$V_T$ Differential-input threshold voltage	20	$V_{ref} = 15 \text{ mV}$	$T_A = 0^\circ\text{C to } 70^\circ\text{C}$	11	15	19	mV
			$T_A = -55^\circ\text{C to } 125^\circ\text{C}$ , SN55232 only	10	15	20	
		$V_{ref} = 40 \text{ mV}$	$T_A = 0^\circ\text{C to } 70^\circ\text{C}$	36	40	44	
			$T_A = -55^\circ\text{C to } 125^\circ\text{C}$ , SN55232 only	35	40	45	
$V_{ICF}$ Common-mode input firing voltage (see Note 3)	none	$V_{ref} = 40 \text{ mV}$ , $V_I(S) = V_{IH}$ Common-mode input pulse: $t_r < 15 \text{ ns}$ , $t_f < 15 \text{ ns}$ , $t_w = 50 \text{ ns}$		$\pm 2.5$		V	
$I_{IB}$ Differential-input bias current	2	$V_{CC+} = 5.25 \text{ V}$ , $V_{CC-} = -5.25 \text{ V}$ , $V_{ID} = 0$	$T_A = -55^\circ\text{C to } 0^\circ\text{C}$ , SN55232 only		100	$\mu\text{A}$	
			$T_A = 0^\circ\text{C to } 70^\circ\text{C}$	30	75		
		$T_A = 70^\circ\text{C to } 125^\circ\text{C}$ , SN55232 only		75			
$I_{IO}$ Differential-input offset current	2	$V_{CC+} = 5.25 \text{ V}$ , $V_{CC-} = -5.25 \text{ V}$ , $V_{ID} = 0$		0.5		$\mu\text{A}$	
$V_{IH}$ High-level input voltage (strobe inputs)	21			2		V	
$V_{IL}$ Low-level input voltage (strobe inputs)	21				0.8	V	
$I_{OH}$ High-level output current	21	$V_{CC+} = 4.75 \text{ V}$ , $V_{CC-} = -4.75 \text{ V}$ , $V_{OH} = 5.25 \text{ V}$			250	$\mu\text{A}$	
$V_{OL}$ Low-level output voltage	21	$V_{CC+} = 4.75 \text{ V}$ , $V_{CC-} = -4.75 \text{ V}$ , $I_{OL} = 16 \text{ mA}$		0.25	0.4	V	
$I_{IH}$ High-level input current (strobe inputs)	22	$V_{CC+} = 5.25 \text{ V}$ , $V_{CC-} = -5.25 \text{ V}$ , $V_{IH} = 2.4 \text{ V}$		40		$\mu\text{A}$	
		$V_{CC+} = 5.25 \text{ V}$ , $V_{CC-} = -5.25 \text{ V}$ , $V_{IH} = 5.25 \text{ V}$			1	$\text{mA}$	
$I_{IL}$ Low-level input current (strobe inputs)	22	$V_{CC+} = 5.25 \text{ V}$ , $V_{CC-} = -5.25 \text{ V}$ , $V_{IL} = 0.4 \text{ V}$		-1	-1.6	$\text{mA}$	
$I_{CC+}$ Supply current from $V_{CC+}$	6	$V_{CC+} = 5.25 \text{ V}$ , $V_{CC-} = -5.25 \text{ V}$ , $T_A = 25^\circ\text{C}$		25	40	$\text{mA}$	
$I_{CC-}$ Supply current from $V_{CC-}$	6	$V_{CC+} = 5.25 \text{ V}$ , $V_{CC-} = -5.25 \text{ V}$ , $T_A = 25^\circ\text{C}$		-15	-20	$\text{mA}$	

<sup>‡</sup>All typical values are at  $V_{CC+} = 5 \text{ V}$ ,  $V_{CC-} = -5 \text{ V}$ ,  $T_A = 25^\circ\text{C}$ .

NOTE 3: Common-mode input firing voltage is the minimum common-mode voltage that will exceed the dynamic range of the input at the specified conditions and cause the logic output to switch. The common-mode input signal is applied when the strobe is high.

# TYPES SN55232, SN75232 DUAL SENSE AMPLIFIERS

switching characteristics,  $V_{CC+} = 5\text{ V}$ ,  $V_{CC-} = -5\text{ V}$ ,  $T_A = 25^\circ\text{C}$

PROPAGATION DELAY TIMES			TEST FIGURE	TEST CONDITIONS	MIN	TYP	MAX	UNIT
SYMBOL	FROM INPUT	TO OUTPUT						
$t_{PLH(D)}$	A1-A2	W	35	$C_L = 15\text{ pF}$ , $R_L = 288\ \Omega$	25	25	40	ns
$t_{PHL(D)}$								
$t_{PLH(S)}$	STROBE	W	35	$C_L = 15\text{ pF}$ , $R_L = 288\ \Omega$	25	15	30	ns
$t_{PHL(S)}$								

typical recovery and cycle times,  $V_{CC+} = 5\text{ V}$ ,  $V_{CC-} = -5\text{ V}$ ,  $T_A = 25^\circ\text{C}$

PARAMETER	TEST CONDITIONS	MIN	TYP	MAX	UNIT
$t_{orD}$	Differential-input overload recovery time (see Note 4) <i>Differential Input Pulse:</i> $V_{ID} = 2\text{ V}$ , $t_r = t_f = 20\text{ ns}$		20		ns
$t_{orC}$	Common-mode-input overload recovery time (see Note 5) <i>Common-Mode Input Pulse:</i> $V_{IC} = \pm 2\text{ V}$ , $t_r = t_f = 20\text{ ns}$		20		ns
$t_{cyc(min)}$	Minimum cycle time		200		ns

- NOTES: 4. Differential-input overload recovery time is the time necessary for the device to recover from the specified differential-input-overload signal prior to the strobe-enable signal.  
5. Common-mode-input overload recovery time is the time necessary for the device to recover from the specified common-mode-input overload signal prior to the strobe-enable signal.

## schematic

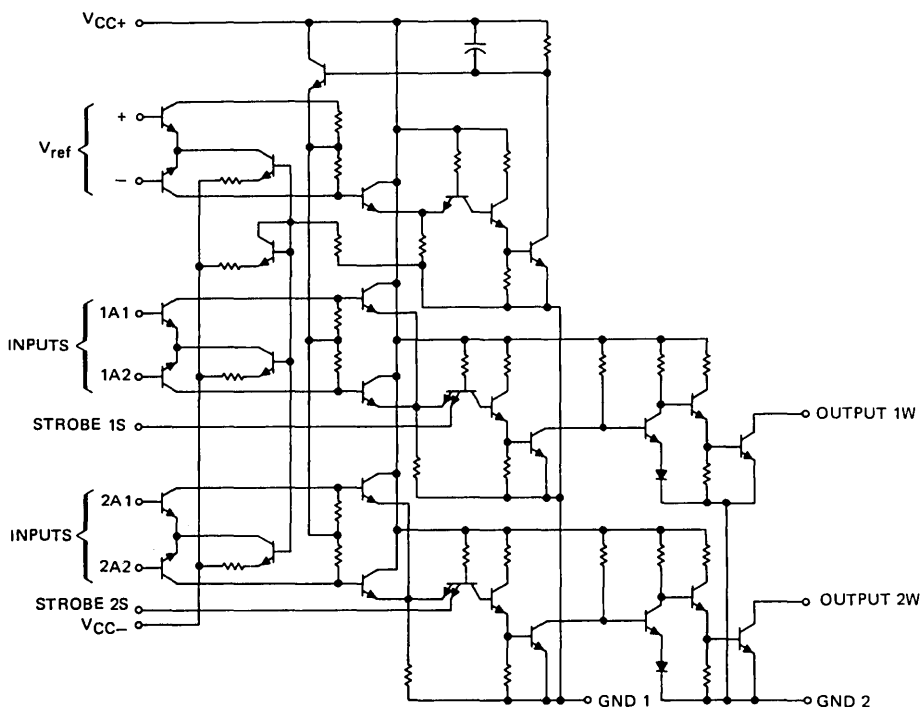

# TYPES SN55234, SN75234

## DUAL SENSE AMPLIFIERS

FUNCTION TABLE

INPUTS		OUTPUT
A	S	W
H	H	L
L	X	H
X	L	H

### definition of logic levels

INPUT	H	L	X
A†	$V_{ID} > V_{T \max}$	$V_{ID} < V_{T \min}$	Irrelevant
S	$V_I > V_{IH \min}$	$V_I < V_{IL \max}$	Irrelevant

†A is a differential voltage ( $V_{ID}$ ) between A1 and A2. For these circuits,  $V_{ID}$  is considered positive regardless of which terminal is positive with respect to the other.

JORN  
DUAL-IN-LINE PACKAGE (TOP VIEW)

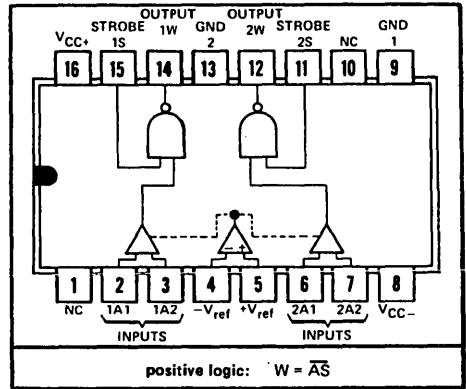

NC—No internal connection

electrical characteristics over recommended operating free-air temperature range,  $V_{CC+} = 5\text{ V}$ ,  $V_{CC-} = -5\text{ V}$  (unless otherwise noted)

PARAMETER	TEST FIGURE	TEST CONDITIONS			MIN	TYP‡	MAX	UNIT
		$V_{ref} = 15\text{ mV}$	$T_A = 0^\circ\text{C to } 70^\circ\text{C}$	$T_A = -55^\circ\text{C to } 125^\circ\text{C, SN55234 only}$				
$V_T$ Differential-input threshold voltage	20	$V_{ref} = 15\text{ mV}$	$T_A = 0^\circ\text{C to } 70^\circ\text{C}$	$T_A = -55^\circ\text{C to } 125^\circ\text{C, SN55234 only}$	11	15	19	mV
		$V_{ref} = 40\text{ mV}$	$T_A = 0^\circ\text{C to } 70^\circ\text{C}$	$T_A = -55^\circ\text{C to } 125^\circ\text{C, SN55234 only}$	36	40	44	
$V_{ICF}$ Common-mode input firing voltage (see Note 3)	none	$V_{ref} = 40\text{ mV}$ , $t_r < 15\text{ ns}$ , $t_f < 15\text{ ns}$ , $t_w = 50\text{ ns}$	$V_I(S) * V_{IH}$ Common-mode input pulse:		±2.5			V
$I_{IB}$ Differential-input bias current	2	$V_{CC+} = 5.25\text{ V}$ , $V_{CC-} = -5.25\text{ V}$ , $V_{ID} = 0$	$T_A = -55^\circ\text{C to } 0^\circ\text{C}$ , SN55234 only				100	$\mu\text{A}$
			$T_A = 0^\circ\text{C to } 70^\circ\text{C}$			30	75	
$I_{IO}$ Differential-input offset current	2	$V_{CC+} = 5.25\text{ V}$ , $V_{CC-} = -5.25\text{ V}$ , $V_{ID} = 0$	$T_A = 70^\circ\text{C to } 125^\circ\text{C}$ , SN55234 only		0.5			$\mu\text{A}$
$V_{IH}$ High-level input voltage (strobe inputs)	21				2			V
$V_{IL}$ Low-level input voltage (strobe inputs)	21						0.8	V
$V_{OH}$ High-level output voltage	21	$V_{CC+} = 4.75\text{ V}$ , $V_{CC-} = -4.75\text{ V}$ , $I_{OH} = -400\text{ }\mu\text{A}$			2.4	4		V
$V_{OL}$ Low-level output voltage	21	$V_{CC+} = 4.75\text{ V}$ , $V_{CC-} = -4.75\text{ V}$ , $I_{OL} = 16\text{ mA}$			0.25	0.4		V
$I_{IH}$ High-level input current (strobe inputs)	22	$V_{CC+} = 5.25\text{ V}$ , $V_{CC-} = -5.25\text{ V}$ , $V_{IH} = 2.4\text{ V}$					40	$\mu\text{A}$
			$V_{CC+} = 5.25\text{ V}$ , $V_{CC-} = -5.25\text{ V}$ , $V_{IH} = 5.25\text{ V}$			1		
$I_{IL}$ Low-level input current (strobe inputs)	22	$V_{CC+} = 5.25\text{ V}$ , $V_{CC-} = -5.25\text{ V}$ , $V_{IL} = 0.4\text{ V}$			-1	-1.6		mA
$I_{OS}$ Short-circuit output current	23	$V_{CC+} = 5.25\text{ V}$ , $V_{CC-} = -5.25\text{ V}$ , $T_A = 25^\circ\text{C}$			-2.1	-3.5		mA
$I_{CC+}$ Supply current from $V_{CC+}$	6	$V_{CC+} = 5.25\text{ V}$ , $V_{CC-} = -5.25\text{ V}$ , $T_A = 25^\circ\text{C}$			25	40		mA
$I_{CC-}$ Supply current from $V_{CC-}$	6	$V_{CC+} = 5.25\text{ V}$ , $V_{CC-} = -5.25\text{ V}$ , $T_A = 25^\circ\text{C}$			-15	-20		mA

‡All typical values are at  $V_{CC+} = 5\text{ V}$ ,  $V_{CC-} = -5\text{ V}$ ,  $T_A = 25^\circ\text{C}$ .

NOTE 3: Common-mode input firing voltage is the minimum common-mode voltage that will exceed the dynamic range of the input at the specified conditions and cause the logic output to switch. The common-mode input signal is applied when the strobe is high.



# TYPES SN55234, SN75234 DUAL SENSE AMPLIFIERS

switching characteristics,  $V_{CC+} = 5\text{ V}$ ,  $V_{CC-} = -5\text{ V}$ ,  $T_A = 25^\circ\text{C}$

PROPAGATION DELAY TIMES			TEST FIGURE	TEST CONDITIONS	MIN	TYP	MAX	UNIT
SYMBOL	FROM INPUT	TO OUTPUT						
$t_{PLH(D)}$	A1-A2	W	35	$C_L = 15\text{ pF}$ , $R_L = 288\ \Omega$		25		ns
$t_{PHL(D)}$								
$t_{PLH(S)}$	STROBE	W	35	$C_L = 15\text{ pF}$ , $R_L = 288\ \Omega$		25		ns
$t_{PHL(S)}$								

typical recovery and cycle times,  $V_{CC+} = 5\text{ V}$ ,  $V_{CC-} = -5\text{ V}$ ,  $T_A = 25^\circ\text{C}$

PARAMETER	TEST CONDITIONS	MIN	TYP	MAX	UNIT
$t_{orD}$	Differential-input overload recovery time (see Note 4) <i>Differential Input Pulse:</i> $V_{ID} = 2\text{ V}$ , $t_r = t_f = 20\text{ ns}$		20		ns
$t_{orC}$	Common-mode-input overload recovery time (see Note 5) <i>Common-Mode Input Pulse:</i> $V_{IC} = \pm 2\text{ V}$ , $t_r = t_f = 20\text{ ns}$		20		ns
$t_{cyc(min)}$	Minimum cycle time		200		ns

- NOTES: 4. Differential-input overload recovery time is the time necessary for the device to recover from the specified differential-input-overload signal prior to the strobe-enable signal.  
5. Common-mode-input overload recovery time is the time necessary for the device to recover from the specified common-mode-input overload signal prior to the strobe-enable signal.

## schematic

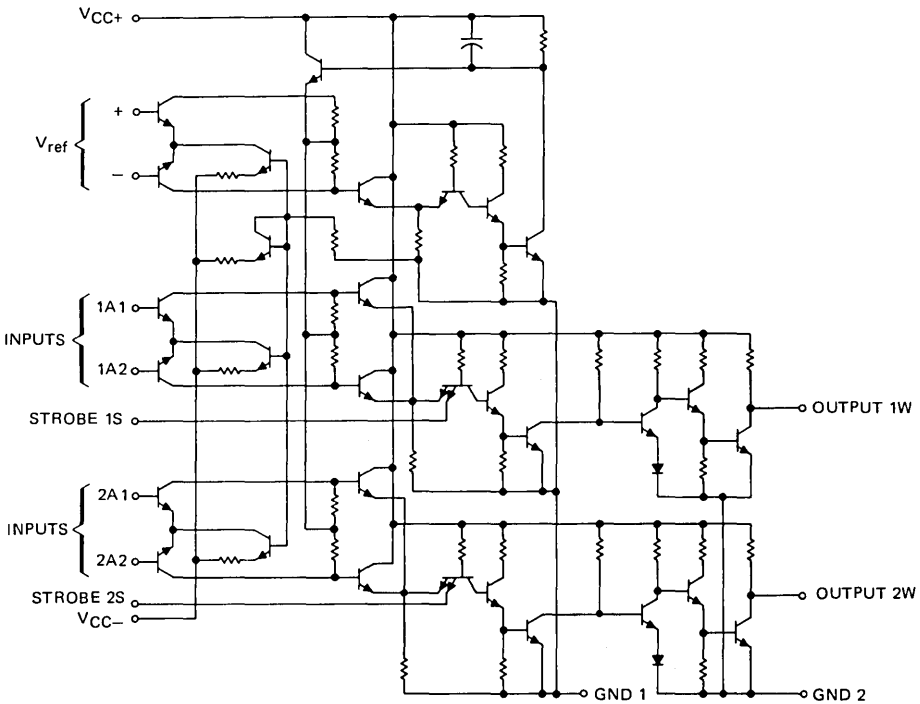

# TYPES SN55238, SN75238

## DUAL SENSE AMPLIFIERS WITH PREAMPLIFIER TEST POINTS

FUNCTION TABLE

INPUTS		OUTPUT
A	S	W
H	H	L
L	X	H
X	L	H

definition of logic levels

INPUT	H	L	X
A†	$V_{ID} \geq V_T \text{ max}$	$V_{ID} \leq V_T \text{ min}$	Irrelevant
S	$V_I \geq V_{IH} \text{ min}$	$V_I \leq V_{IL} \text{ max}$	Irrelevant

†A is a differential voltage ( $V_{ID}$ ) between A1 and A2. For these circuits,  $V_{ID}$  is considered positive regardless of which terminal is positive with respect to the other.

J OR N  
DUAL-IN-LINE PACKAGE (TOP VIEW)

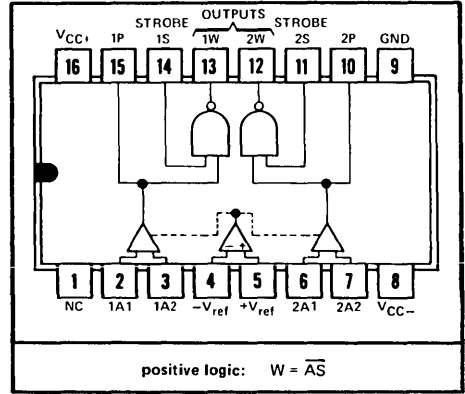

NC—No internal connection

electrical characteristics over recommended operating free-air temperature range,  $V_{CC+} = 5 \text{ V}$ ,  $V_{CC-} = -5 \text{ V}$  (unless otherwise noted)

PARAMETER	TEST FIGURE	TEST CONDITIONS	MIN	TYP <sup>‡</sup>	MAX	UNIT	
$V_T$ Differential-input threshold voltage	24	$V_{ref} = 15 \text{ mV}$	$T_A = 0^\circ\text{C to } 70^\circ\text{C}$	11	15	19	mV
			$T_A = -55^\circ\text{C to } 125^\circ\text{C}$ , SN55238 only	10	15	20	
		$V_{ref} = 40 \text{ mV}$	$T_A = 0^\circ\text{C to } 70^\circ\text{C}$	36	40	44	
			$T_A = -55^\circ\text{C to } 125^\circ\text{C}$ , SN55238 only	35	40	45	
$V_{ICF}$ Common-mode input firing voltage (see Note 3)	none	$V_{ref} = 40 \text{ mV}$ , $V_I(S) = V_{IH}$ Common-mode input pulse: $t_r \leq 15 \text{ ns}$ , $t_f \leq 15 \text{ ns}$ , $t_w = 50 \text{ ns}$		$\pm 2.5$		V	
$I_{IB}$ Differential-input bias current	2	$V_{CC+} = 5.25 \text{ V}$ , $V_{CC-} = -5.25 \text{ V}$ , $V_{ID} = 0$	$T_A = -55^\circ\text{C to } 0^\circ\text{C}$ , SN55238 only			100	$\mu\text{A}$
			$T_A = 0^\circ\text{C to } 70^\circ\text{C}$			30	
		$T_A = 70^\circ\text{C to } 125^\circ\text{C}$ , SN55238 only				75	
$I_{IO}$ Differential-input offset current	2	$V_{CC+} = 5.25 \text{ V}$ , $V_{CC-} = -5.25 \text{ V}$ , $V_{ID} = 0$			0.5	$\mu\text{A}$	
$V_{IH}$ High-level input voltage (strobe inputs)	25			2		V	
$V_{IL}$ Low-level input voltage (strobe inputs)	25				0.8	V	
$V_{OH}$ High-level output voltage	25	$V_{CC+} = 4.75 \text{ V}$ , $V_{CC-} = -4.75 \text{ V}$ , $I_{OH} = -400 \mu\text{A}$	2.4		4	V	
$V_{OL}$ Low-level output voltage	25	$V_{CC+} = 4.75 \text{ V}$ , $V_{CC-} = -4.75 \text{ V}$ , $I_{OL} = 16 \text{ mA}$		0.25	0.4	V	
$I_{IH}$ High-level input current (strobe inputs)	26	$V_{CC+} = 5.25 \text{ V}$ , $V_{CC-} = -5.25 \text{ V}$ , $V_{IH} = 2.4 \text{ V}$				40	$\mu\text{A}$
		$V_{CC+} = 5.25 \text{ V}$ , $V_{CC-} = -5.25 \text{ V}$ , $V_{IH} = 5.25 \text{ V}$				1	
$I_{IL}$ Low-level input current (strobe inputs)	26	$V_{CC+} = 5.25 \text{ V}$ , $V_{CC-} = -5.25 \text{ V}$ , $V_{IL} = 0.4 \text{ V}$		-1	-1.6	mA	
$I_{OS}$ Short-circuit output current	27	$V_{CC+} = 5.25 \text{ V}$ , $V_{CC-} = -5.25 \text{ V}$ , $T_A = 25^\circ\text{C}$	-2.1		-3.5	mA	
$I_{CC+}$ Supply current from $V_{CC+}$	6	$V_{CC+} = 5.25 \text{ V}$ , $V_{CC-} = -5.25 \text{ V}$ , $T_A = 25^\circ\text{C}$		25	40	mA	
$I_{CC-}$ Supply current from $V_{CC-}$	6	$V_{CC+} = 5.25 \text{ V}$ , $V_{CC-} = -5.25 \text{ V}$ , $T_A = 25^\circ\text{C}$		-15	-20	mA	

<sup>‡</sup>All typical values are at  $V_{CC+} = 5 \text{ V}$ ,  $V_{CC-} = -5 \text{ V}$ ,  $T_A = 25^\circ\text{C}$ .

NOTE 3: Common-mode input firing voltage is the minimum common-mode voltage that will exceed the dynamic range of the input at the specified conditions and cause the logic output to switch. The common-mode input signal is applied when the strobe is high.

# TYPES SN55238, SN75238

## DUAL SENSE AMPLIFIERS WITH PREAMPLIFIER TEST POINTS

switching characteristics,  $V_{CC+} = 5\text{ V}$ ,  $V_{CC-} = -5\text{ V}$ ,  $T_A = 25^\circ\text{C}$

PROPAGATION DELAY TIMES			TEST FIGURE	TEST CONDITIONS	MIN	TYP	MAX	UNIT
SYMBOL	FROM INPUT	TO OUTPUT						
$t_{PLH(D)}$	A1-A2	W	36	$C_L = 15\text{ pF}$ , $R_L = 288\ \Omega$		25		ns
$t_{PHL(D)}$								
$t_{PLH(S)}$	STROBE	W	36	$C_L = 15\text{ pF}$ , $R_L = 288\ \Omega$		25		ns
$t_{PHL(S)}$								

typical recovery and cycle times,  $V_{CC+} = 5\text{ V}$ ,  $V_{CC-} = -5\text{ V}$ ,  $T_A = 25^\circ\text{C}$

PARAMETER	TEST CONDITIONS	MIN	TYP	MAX	UNIT
$t_{orD}$	Differential-input overload recovery time (see Note 4) <i>Differential Input Pulse:</i> $V_{ID} = 2\text{ V}$ , $t_f = 20\text{ ns}$		20		ns
$t_{orC}$	Common-mode-input overload recovery time (see Note 5) <i>Common-Mode Input Pulse:</i> $V_{IC} = \pm 2\text{ V}$ , $t_r = t_f = 20\text{ ns}$		20		ns
$t_{cyc(min)}$	Minimum cycle time		200		ns

- NOTES: 4. Differential-input overload recovery time is the time necessary for the device to recover from the specified differential-input overload signal prior to the strobe-enable signal.  
5. Common-mode-input overload recovery time is the time necessary for the device to recover from the specified common-mode-input overload signal prior to the strobe-enable signal.

schematic

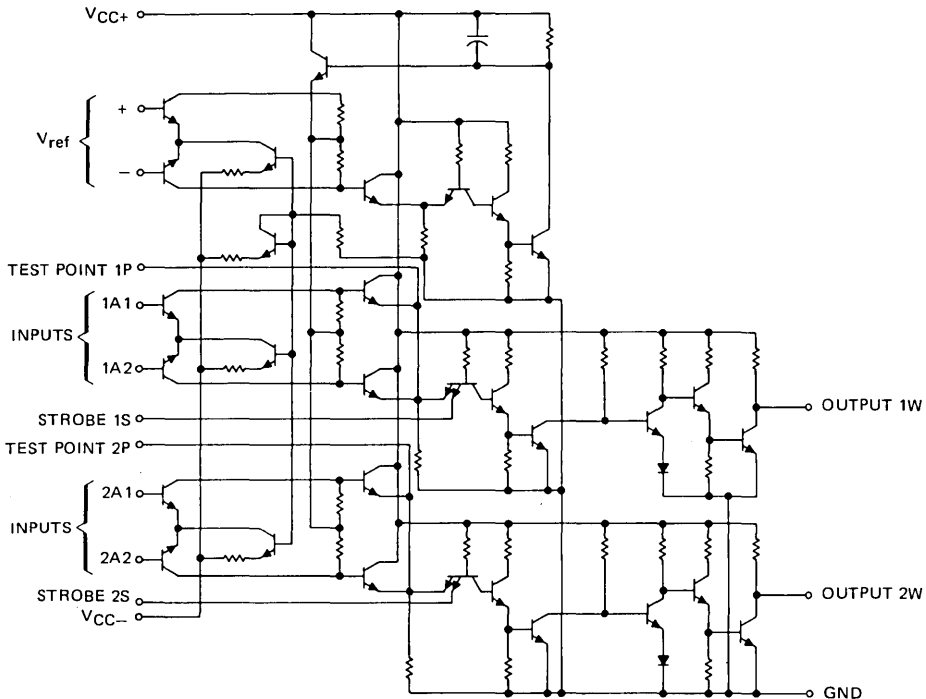

6

# SERIES 5520/7520 SENSE AMPLIFIERS

## PARAMETER MEASUREMENT INFORMATION

d-c test circuits†

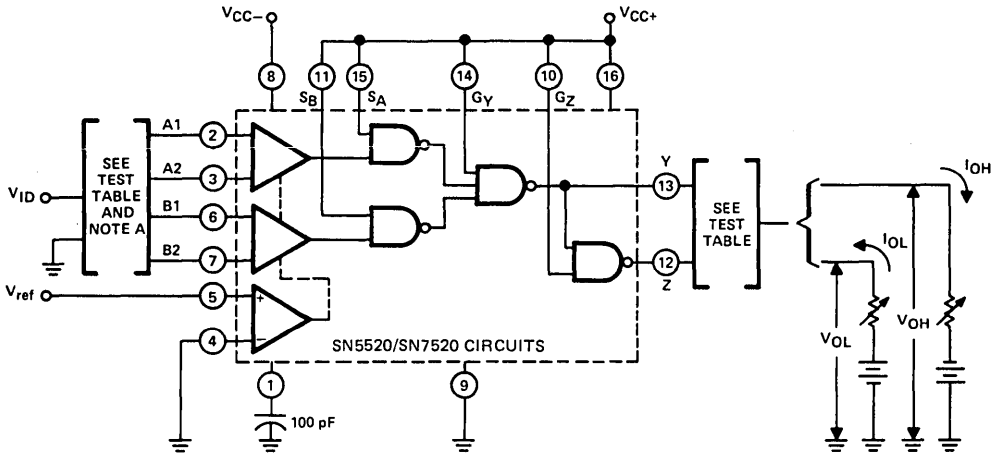

TEST TABLE

CIRCUIT TYPE	INPUTS	$V_{ref}$	$V_{ID}$	OUTPUT Y			OUTPUT Z		
				$V_O$	$I_{OH}$	$I_{OL}$	$V_O$	$I_{OH}$	$I_{OL}$
SN5520/ SN7520	A1-A2 or B1-B2	15 mV	$\leq 11$ mV	$\leq 0.4$ V		16 mA	$\geq 2.4$ V	$-400 \mu A$	
	A1-A2 or B1-B2	15 mV	$> 19$ mV	$\geq 2.4$ V	$-400 \mu A$		$\leq 0.4$ V		16 mA
	A1-A2 or B1-B2	40 mV	$\leq 36$ mV	$\leq 0.4$ V		16 mA	$\geq 2.4$ V	$-400 \mu A$	
	A1-A2 or B1-B2	40 mV	$> 44$ mV	$\geq 2.4$ V	$-400 \mu A$		$\leq 0.4$ V		16 mA

NOTE A: Each pair of differential inputs is tested separately with the other pair grounded.

FIGURE 1-V<sub>T</sub>

†Arrows indicate actual direction of current flow. Current into a terminal is a positive value.

# SERIES 5520/7520 SENSE AMPLIFIERS

## PARAMETER MEASUREMENT INFORMATION

d-c test circuits† (continued)

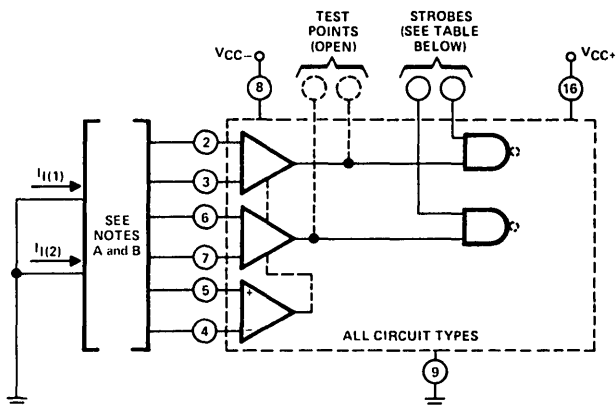

- NOTES: A. Each preamplifier is tested separately. Inputs not under test are grounded.  
 B.  $I_{IB} = I_{1(1)}$  or  $I_{1(2)}$  (limit applies to each);  $I_{IO} = I_{1(1)} - I_{1(2)}$ ;  $I_{1(1)}$  and  $I_{1(2)}$  are the currents into the two inputs of the pair under test.

### PIN CONNECTIONS (OTHER THAN THOSE SHOWN ABOVE)

CIRCUIT TYPES	100 pF to GND	APPLY $V_{CC+}$	APPLY GND	LEAVE OPEN	OTHER
SN5520, SN7520	$C_{ext}$ ①	$G_Y, G_Z$ ⑭ ⑩	$S_A, S_B$ ⑮ ⑪	$Y, Z$ ⑬ ⑫	
SN5522, SN7522	$C_{ext}$ ①	$G$ ⑭	$S_A, S_B, GND 2$ ⑮ ⑪ ⑬		$R_L, Y$ ⑩ ⑫
SN5524, SN7524	$C_{ext}$ ①		$1S, 2S, GND 2$ ⑮ ⑪ ⑬	$1W, 2W$ ⑭ ⑫	
SN5528, SN7528	$C_{ext}$ ①		$1S, 2S$ ⑭ ⑪	$1P, 2P, 1W, 2W$ ⑮ ⑩ ⑬ ⑫	
SN55232, SN75232, SN55234, SN75234			$1S, 2S, GND 2$ ⑮ ⑪ ⑬	$1W, 2W$ ⑭ ⑫	
SN55238, SN75238			$1S, 2S$ ⑭ ⑪	$1P, 2P, 1W, 2W$ ⑮ ⑩ ⑬ ⑫	

FIGURE 2— $I_{IB}, I_{IO}$

† Arrows indicate actual direction of current flow. Current into a terminal is a positive value.

# SERIES 5520/7520 SENSE AMPLIFIERS

## PARAMETER MEASUREMENT INFORMATION

d-c test circuits<sup>†</sup> (continued)

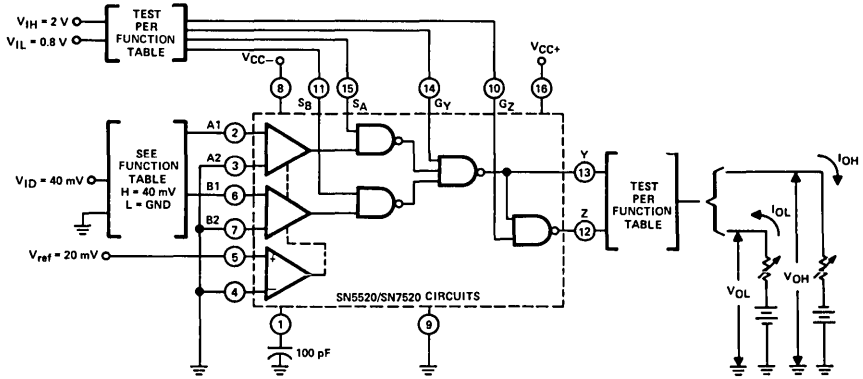
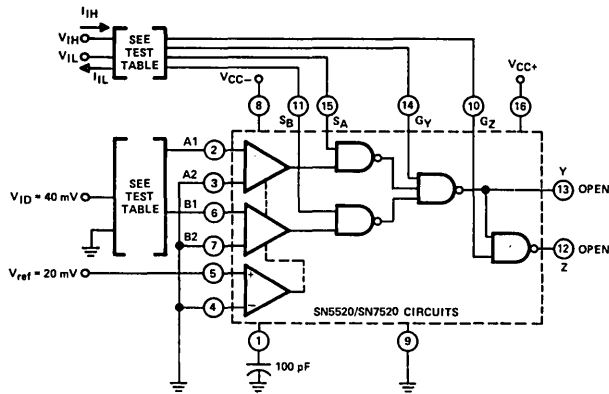

FIGURE 3— $V_{IH}$ ,  $V_{IL}$ ,  $V_{OH}$ ,  $V_{OL}$



TEST TABLE

TEST	INPUT A1	INPUT B1	STROBE $S_A$	STROBE $S_B$	GATE $G_Y$	GATE $G_Z$
$I_{IH}$ at STROBE $S_A$	GND	GND	$V_{IH}$	$V_{IL}$	$V_{IL}$	$V_{IL}$
$I_{IH}$ at STROBE $S_B$	GND	GND	$V_{IL}$	$V_{IH}$	$V_{IL}$	$V_{IL}$
$I_{IH}$ at GATE $G_Y$	$V_{ID}$	$V_{ID}$	$V_{IH}$	$V_{IH}$	$V_{IH}$	$V_{IL}$
$I_{IH}$ at GATE $G_Z$	GND	GND	$V_{IL}$	$V_{IL}$	$V_{IH}$	$V_{IH}$
$I_{IL}$ at STROBE $S_A$	$V_{ID}$	GND	$V_{IL}$	$V_{IL}$	$V_{IL}$	$V_{IL}$
$I_{IL}$ at STROBE $S_B$	GND	$V_{ID}$	$V_{IL}$	$V_{IL}$	$V_{IL}$	$V_{IL}$
$I_{IL}$ at GATE $G_Y$	GND	GND	$V_{IL}$	$V_{IL}$	$V_{IL}$	$V_{IL}$
$I_{IL}$ at GATE $G_Z$	GND	GND	$V_{IL}$	$V_{IL}$	$V_{IL}$	$V_{IL}$

FIGURE 4— $I_{IH}$ ,  $I_{IL}$

<sup>†</sup>Arrows indicate actual direction of current flow. Current into a terminal is a positive value.

# SERIES 5520/7520 SENSE AMPLIFIERS

## PARAMETER MEASUREMENT INFORMATION

d-c test circuits† (continued)

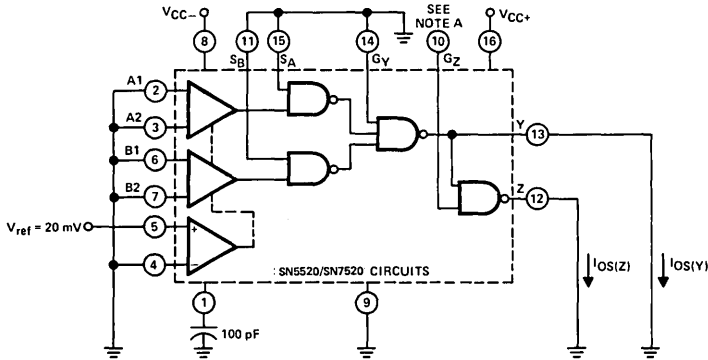
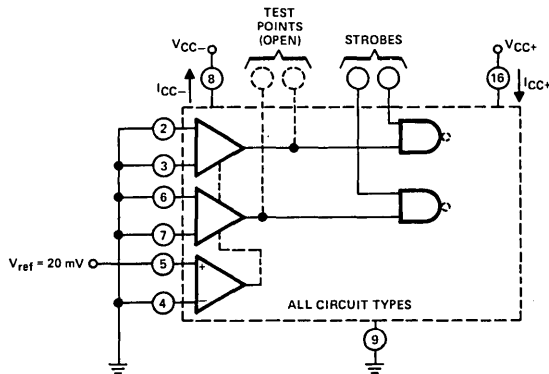

FIGURE 5-I<sub>OS</sub>

NOTE A: When testing I<sub>OS</sub>(Y), Pin 10 is open; when testing I<sub>OS</sub>(Z), Pin 10 is grounded.



PIN CONNECTIONS (OTHER THAN THOSE SHOWN ABOVE)

CIRCUIT TYPES	100 pF to GND	APPLY GND	LEAVE OPEN
SN5520, SN7520	C <sub>ext</sub> ①	G <sub>Y</sub> , G <sub>Z</sub> , S <sub>A</sub> , S <sub>B</sub> ⑭ ⑩ ⑮ ⑪	Y, Z ⑬ ⑫
SN5522, SN7522	C <sub>ext</sub> ①	G, S <sub>A</sub> , S <sub>B</sub> , GND 2 ⑭ ⑮ ⑪ ⑬	R <sub>L</sub> , Y ⑩ ⑫
SN5524, SN7524	C <sub>ext</sub> ①	1S, 2S, GND 2 ⑮ ⑪ ⑬	1W, 2W ⑭ ⑫
SN5528, SN7528	C <sub>ext</sub> ①	1S, 2S ⑭ ⑪	1P, 2P, 1W, 2W ⑮ ⑩ ⑬ ⑫
SN55232, SN75232, SN55234, SN75234		1S, 2S, GND 2 ⑮ ⑪ ⑬	1W, 2W ⑭ ⑫
SN55238, SN75238		1S, 2S ⑭ ⑪	1P, 2P, 1W, 2W ⑮ ⑩ ⑬ ⑫

FIGURE 6-I<sub>CC+</sub>, I<sub>CC-</sub>

† Arrows indicate actual direction of current flow. Current into a terminal is a positive value.

# SERIES 5520/7520 SENSE AMPLIFIERS

## PARAMETER MEASUREMENT INFORMATION

d-c test circuits† (continued)

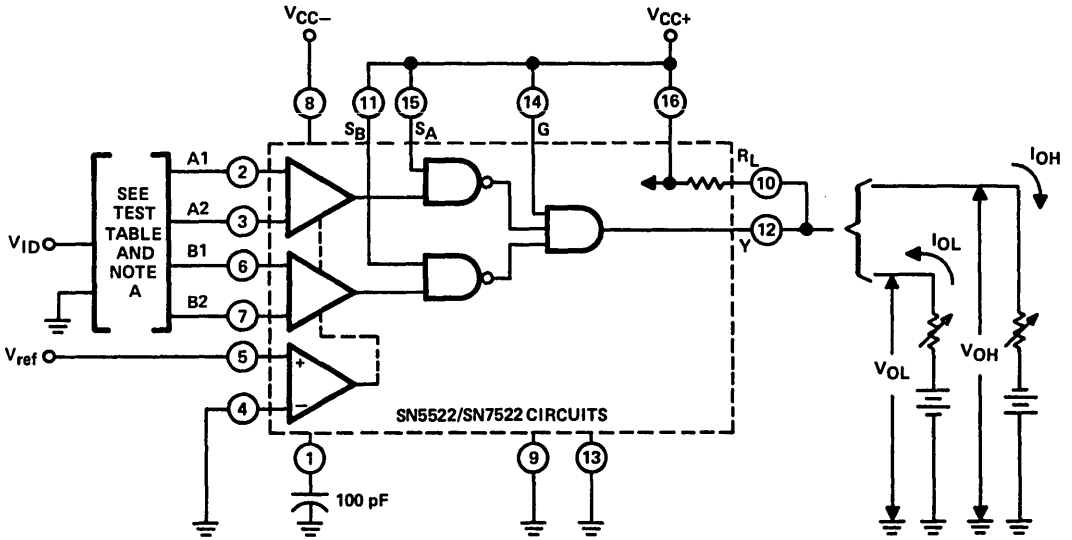

TEST TABLE

CIRCUIT TYPE	INPUTS	$V_{ref}$	$V_{ID}$	OUTPUT		
				$V_O$	$I_{OH}$	$I_{OL}$
SN5522/ SN7522	A1-A2 or B1-B2	15 mV	<11 mV	>2.4 V	-400 $\mu$ A	
	A1-A2 or B1-B2	15 mV	>19 mV	<0.4 V		16 mA
	A1-A2 or B1-B2	40 mV	<36 mV	>2.4 V	-400 $\mu$ A	
	A1-A2 or B1-B2	40 mV	>44 mV	<0.4 V		16 mA

NOTE A: Each pair of differential inputs is tested separately with the other pair grounded.

FIGURE 7-V<sub>T</sub>

† Arrows indicate actual direction of current flow. Current into a terminal is a positive value.



# SERIES 5520/7520 SENSE AMPLIFIERS

## PARAMETER MEASUREMENT INFORMATION

d-c test circuits† (continued)

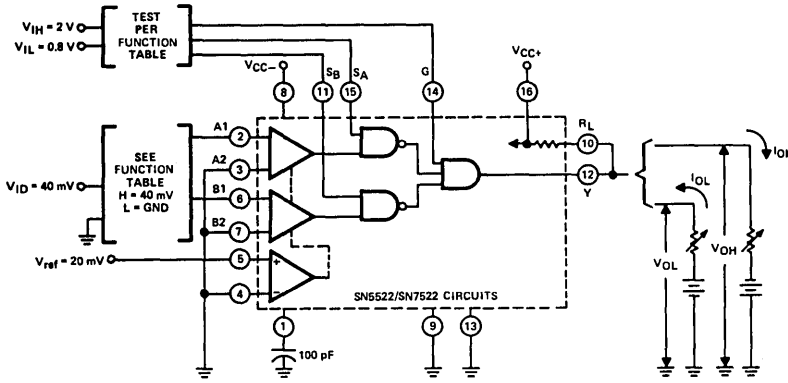
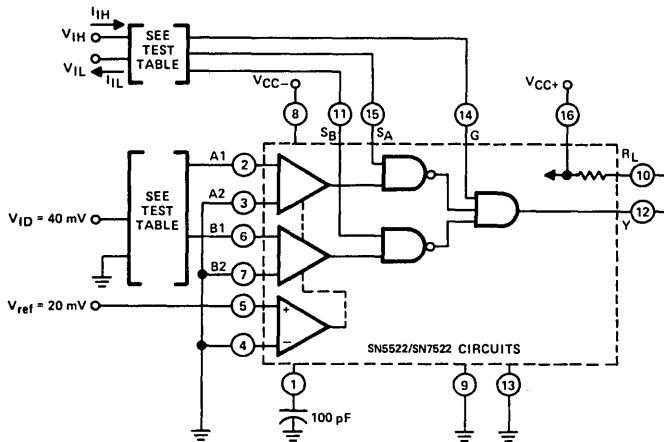

FIGURE 8— $V_{IH}$ ,  $V_{IL}$ ,  $V_{OH}$ ,  $V_{OL}$



TEST TABLE

TEST	INPUT A1	INPUT B1	STROBE $S_A$	STROBE $S_B$	GATE G
$I_{iH}$ at STROBE $S_A$	GND	GND	$V_{IH}$	$V_{IL}$	$V_{IH}$
$I_{iH}$ at STROBE $S_B$	GND	GND	$V_{IL}$	$V_{IH}$	$V_{IH}$
$I_{iH}$ at GATE	$V_{ID}$	$V_{ID}$	$V_{IH}$	$V_{IH}$	$V_{IH}$
$I_{iL}$ at STROBE $S_A$	$V_{ID}$	GND	$V_{IL}$	$V_{IL}$	$V_{IH}$
$I_{iL}$ at STROBE $S_B$	GND	$V_{ID}$	$V_{IL}$	$V_{IL}$	$V_{IH}$
$I_{iL}$ at GATE	GND	GND	$V_{IL}$	$V_{IL}$	$V_{IL}$

FIGURE 9— $I_{iH}$ ,  $I_{iL}$

† Arrows indicate actual direction of current flow. Current into a terminal is a positive value.

# SERIES 5520/7520 SENSE AMPLIFIERS

## PARAMETER MEASUREMENT INFORMATION

d-c test circuits<sup>†</sup> (continued)

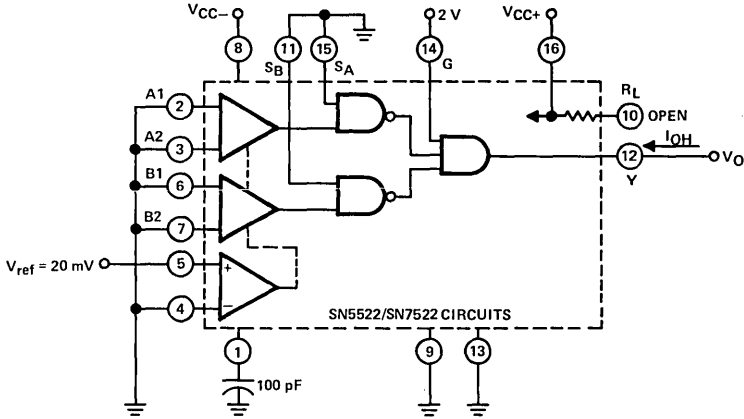

FIGURE 10— $I_{OH}$

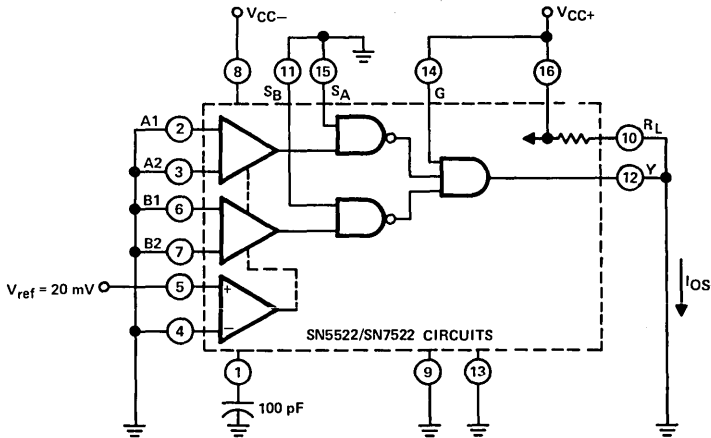

FIGURE 11— $I_{OS}$

<sup>†</sup>Arrows indicate actual direction of current flow. Current into a terminal is a positive value.

# SERIES 5520/7520 SENSE AMPLIFIERS

## PARAMETER MEASUREMENT INFORMATION

d-c test circuits† (continued)

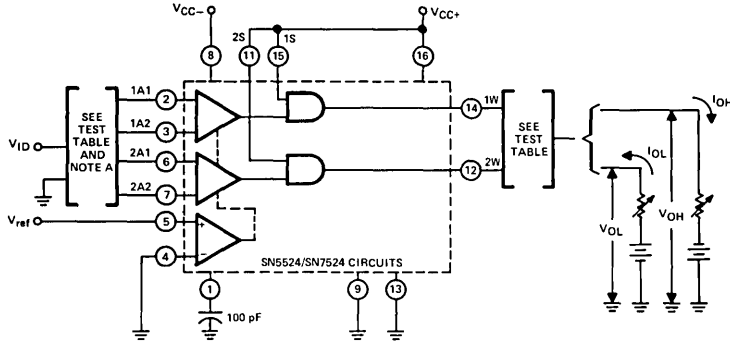

TEST TABLE

CIRCUIT TYPE	INPUTS	$V_{ref}$	$V_{ID}$	OUTPUT		
				$V_O$	$I_{OH}$	$I_{OL}$
SN5524/ SN7524	A1-A2	15 mV	$\leq 11$ mV	$\leq 0.4$ V		16 mA
	A1-A2	15 mV	$\geq 19$ mV	$\geq 2.4$ V	$-400 \mu\text{A}$	
	A1-A2	40 mV	$\leq 36$ mV	$\leq 0.4$ V		16 mA
	A1-A2	40 mV	$\geq 44$ mV	$\geq 2.4$ V	$-400 \mu\text{A}$	

NOTE A: Each pair of differential inputs is tested separately with its corresponding output.

FIGURE 12— $V_T$

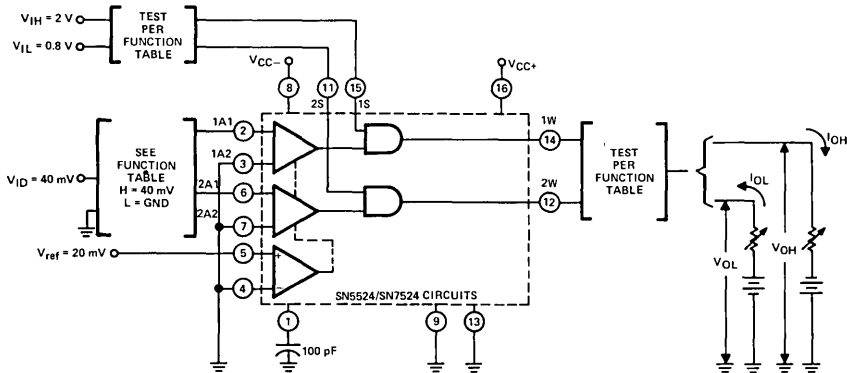

FIGURE 13— $V_{IH}$ ,  $V_{IL}$ ,  $V_{OH}$ ,  $V_{OL}$

†Arrows indicate actual direction of current flow. Current into a terminal is a positive value.

6

# SERIES 5520/7520 SENSE AMPLIFIERS

## PARAMETER MEASUREMENT INFORMATION

d-c test circuits† (continued)

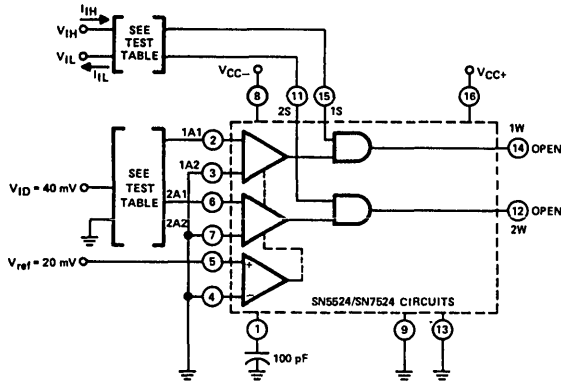

TEST TABLE

TEST	INPUT 1A1	INPUT 2A1	STROBE 1S	STROBE 2S
$I_{IH}$ at STROBE 1S	GND	GND	$V_{IH}$	$V_{IL}$
$I_{IH}$ at STROBE 2S	GND	GND	$V_{IL}$	$V_{IH}$
$I_{IL}$ at STROBE 1S	$V_{ID}$	GND	$V_{IL}$	$V_{IL}$
$I_{IL}$ at STROBE 2S	GND	$V_{ID}$	$V_{IL}$	$V_{IL}$

FIGURE 14— $I_{IH}$ ,  $I_{IL}$

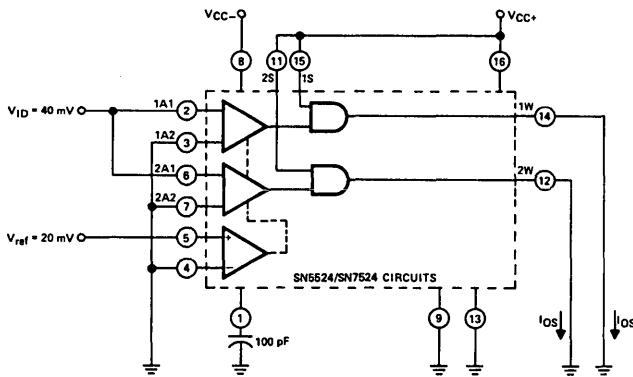

FIGURE 15— $I_{OS}$

†Arrows indicate actual direction of current flow. Current into a terminal is a positive value.

# SERIES 5520/7520 SENSE AMPLIFIERS

## PARAMETER MEASUREMENT INFORMATION

d-c test circuits† (continued)

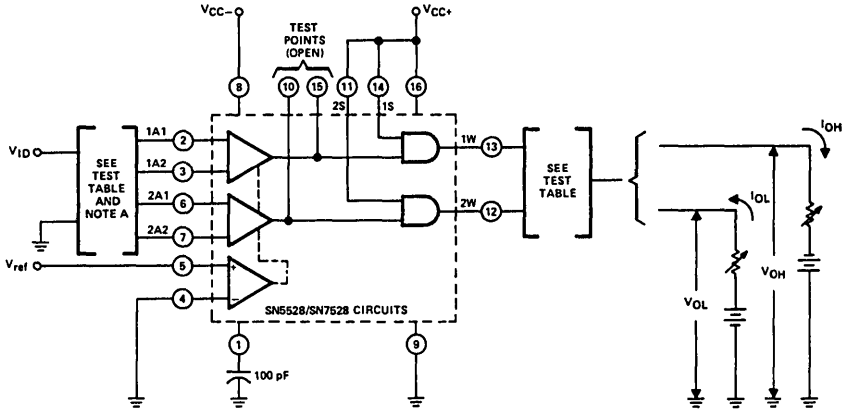

TEST TABLE

CIRCUIT TYPE	INPUTS	$V_{ref}$	$V_{ID}$	OUTPUT		
				$V_O$	$I_{OH}$	$I_{OL}$
SN5528/ SN7528	A1-A2	15 mV	<11 mV	<0.4 V		16 mA
	A1-A2	15 mV	>19 mV	>2.4 V	-400 $\mu$ A	
	A1-A2	40 mV	<36 mV	<0.4 V		16 mA
	A1-A2	40 mV	>44 mV	>2.4 V	-400 $\mu$ A	

NOTE A: Each pair of inputs is tested separately with its corresponding output.

FIGURE 16 -  $V_T$

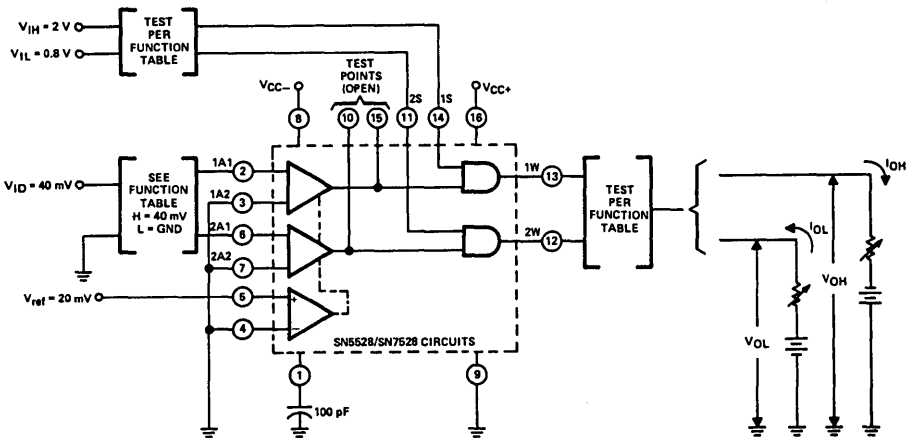

FIGURE 17 -  $V_{IH}$ ,  $V_{IL}$ ,  $V_{OH}$ ,  $V_{OL}$

† Arrows indicate actual direction of current flow. Current into a terminal is a positive value.

# SERIES 5520/7520 SENSE AMPLIFIERS

## PARAMETER MEASUREMENT INFORMATION

d-c test circuits† (continued)

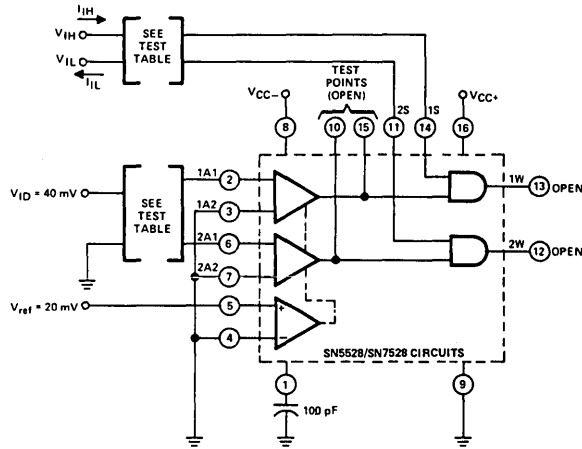

TEST TABLE

TEST	INPUT 1A1	INPUT 2A1	STROBE 1S	STROBE 2S
I <sub>IH</sub> at STROBE 1S	GND	GND	V <sub>IH</sub>	V <sub>IL</sub>
I <sub>IH</sub> at STROBE 2S	GND	GND	V <sub>IL</sub>	V <sub>IH</sub>
I <sub>IL</sub> at STROBE 1S	V <sub>ID</sub>	GND	V <sub>IL</sub>	V <sub>IL</sub>
I <sub>IL</sub> at STROBE 2S	GND	V <sub>ID</sub>	V <sub>IL</sub>	V <sub>IL</sub>

FIGURE 18—I<sub>IH</sub>, I<sub>IL</sub>

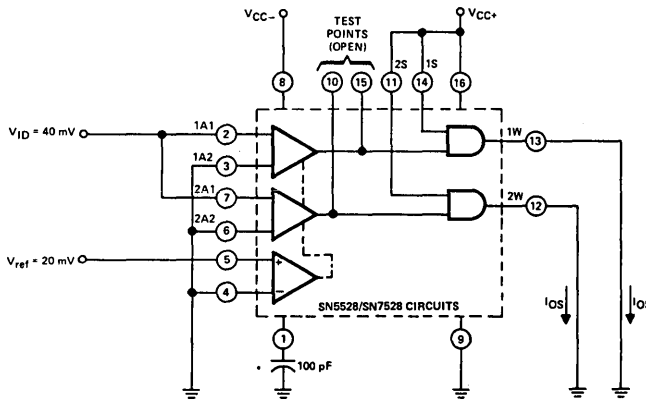

FIGURE 19—I<sub>OS</sub>

† Arrows indicate actual direction of current flow. Current into a terminal is a positive value.

# SERIES 5520/7520 SENSE AMPLIFIERS

## PARAMETER MEASUREMENT INFORMATION

d-c test circuits† (continued)

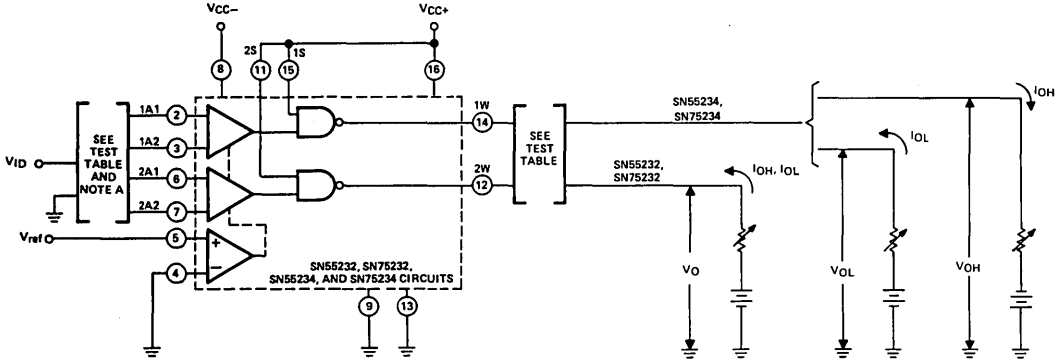

CIRCUIT TYPE	INPUTS	$V_{ref}$	$V_{ID}$	OUTPUTS					
				SN55232, SN75232			SN55234, SN75234		
				$V_O$	$I_{OH}$	$I_{OL}$	$V_O$	$I_{OH}$	$I_{OL}$
SN55232, SN75232,	A1-A2	15 mV	$\leq 11$ mV	5.25 V	$< 250 \mu A$		$\geq 2.4$ V	$-400 \mu A$	
SN55234, SN75234	A1-A2	40 mV	$> 19$ mV	$< 0.4$ V		16 mA	$< 0.4$ V		16 mA
SN55232, SN75232,	A1-A2	40 mV	$\leq 36$ mV	5.25 V	$< 250 \mu A$		$\geq 2.4$ V	$-400 \mu A$	
SN55234, SN75234	A1-A2	40 mV	$> 44$ mV	$< 0.4$ V		16 mA	$< 0.4$ V		16 mA

NOTE A: Each pair of differential inputs is tested separately with its corresponding output.

FIGURE 20— $V_T$

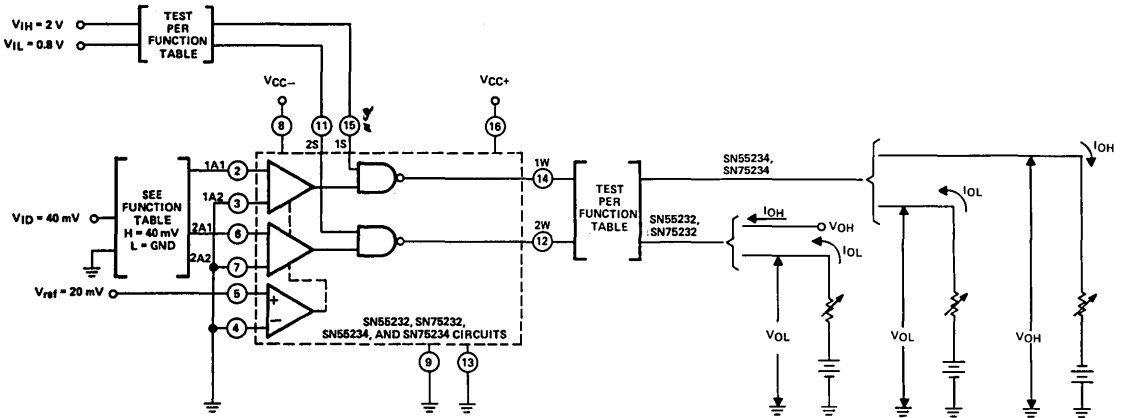

FIGURE 21— $V_{IH}$ ,  $V_{IL}$ ,  $V_{OL}$ ,  $V_{OH}$

† Arrows indicate actual direction of current flow. Current into a terminal is a positive value.

# SERIES 5520/7520 SENSE AMPLIFIERS

## PARAMETER MEASUREMENT INFORMATION

d-c test circuits† (continued)

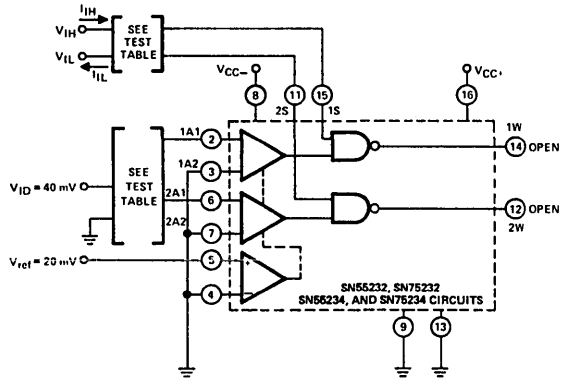

TEST TABLE

TEST	INPUT 1A1	INPUT 2A1	STROBE 1S	STROBE 2S
$I_{IH}$ at STROBE 1S	GND	GND	$V_{IH}$	$V_{IL}$
$I_{IH}$ at STROBE 2S	GND	GND	$V_{IL}$	$V_{IH}$
$I_{IL}$ at STROBE 1S	$V_{ID}$	GND	$V_{IL}$	$V_{IL}$
$I_{IL}$ at STROBE 2S	GND	$V_{ID}$	$V_{IL}$	$V_{IL}$

FIGURE 22— $I_{IH}$ ,  $I_{IL}$

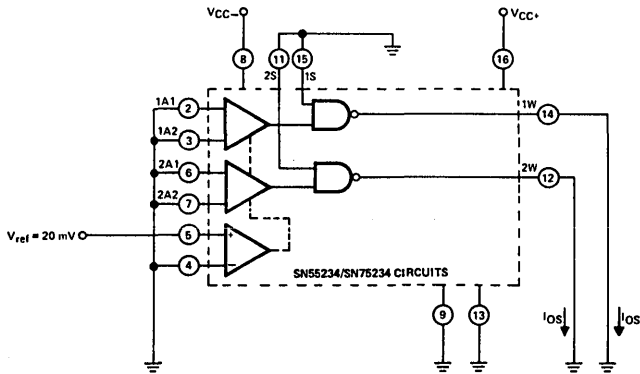

FIGURE 23— $I_{OS}$

† Arrows indicate actual direction of current flow. Current into a terminal is a positive value.



# SERIES 5520/7520 SENSE AMPLIFIERS

## PARAMETER MEASUREMENT INFORMATION

d-c test circuits† (continued)

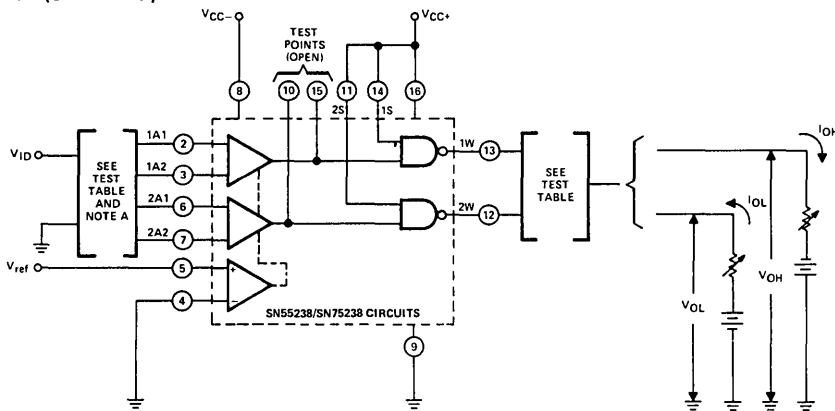

TEST TABLE

CIRCUIT TYPE	INPUTS	$V_{ref}$	$V_{ID}$	OUTPUT		
				$V_O$	$I_{OH}$	$I_{OL}$
SN55238/ SN75238	A1-A2	15 mV	$<11$ mV	$>2.4$ V	$-400$ $\mu$ A	
	A1-A2	15 mV	$>19$ mV	$<0.4$ V		16 mA
	A1-A2	40 mV	$<36$ mV	$>2.4$ V	$-400$ $\mu$ A	
	A1-A2	40 mV	$>44$ mV	$<0.4$ V		16 mA

NOTE A: Each pair of inputs is tested separately with its corresponding output.

FIGURE 24— $V_T$

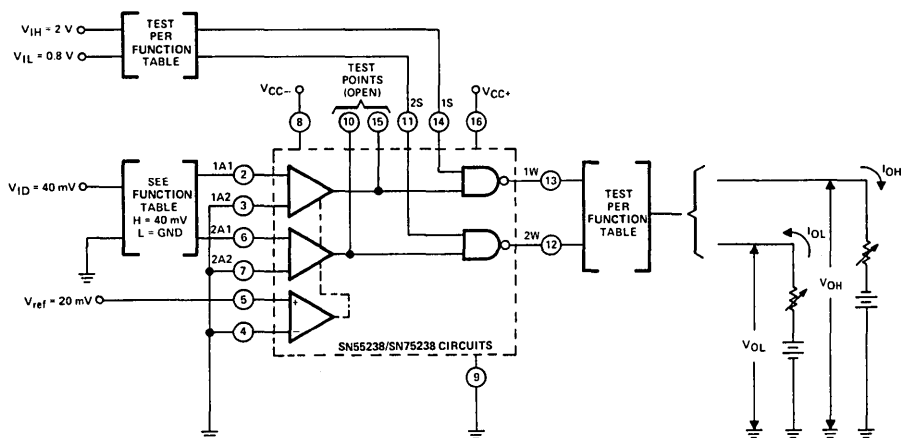

FIGURE 25— $V_{IH}$ ,  $V_{IL}$ ,  $V_{OH}$ ,  $V_{OL}$

† Arrows indicate actual direction of current flow. Current into a terminal is a positive value.

# SERIES 5520/7520 SENSE AMPLIFIERS

## PARAMETER MEASUREMENT INFORMATION

d-c test circuits† (continued)

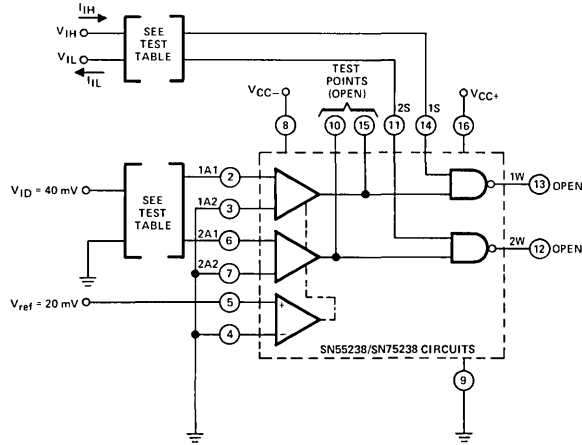

TEST TABLE

TEST	INPUT 1A1	INPUT 2A1	STROBE 1S	STROBE 2S
$I_{IH}$ at STROBE 1S	GND	GND	$V_{IH}$	$V_{IL}$
$I_{IH}$ at STROBE 2S	GND	GND	$V_{IL}$	$V_{IH}$
$I_{IL}$ at STROBE 1S	$V_{ID}$	GND	$V_{IL}$	$V_{IL}$
$I_{IL}$ at STROBE 2S	GND	$V_{ID}$	$V_{IL}$	$V_{IL}$

FIGURE 26— $I_{IH}$ ,  $I_{IL}$

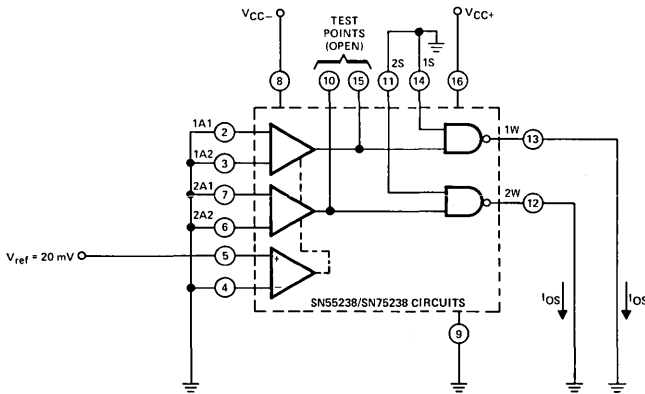

FIGURE 27— $I_{OS}$

†Arrows indicate actual direction of current flow. Current into a terminal is a positive value.

# SERIES 5520/7520 SENSE AMPLIFIERS

## PARAMETER MEASUREMENT INFORMATION

### switching characteristics

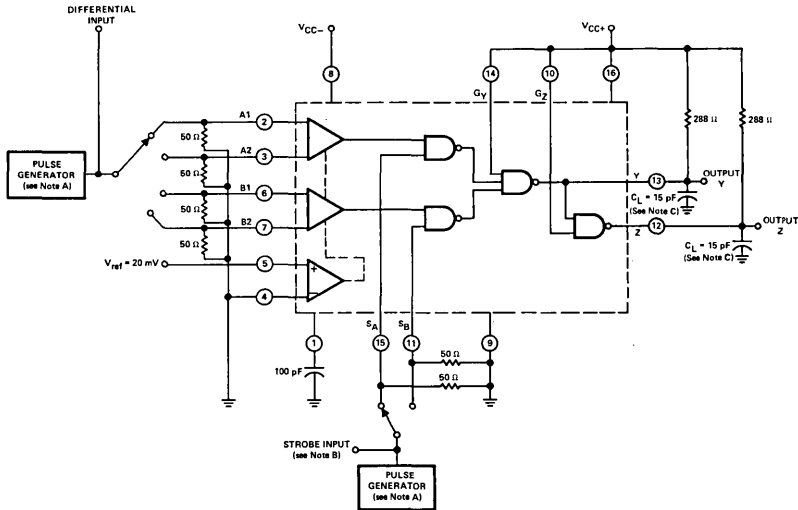

TEST CIRCUIT

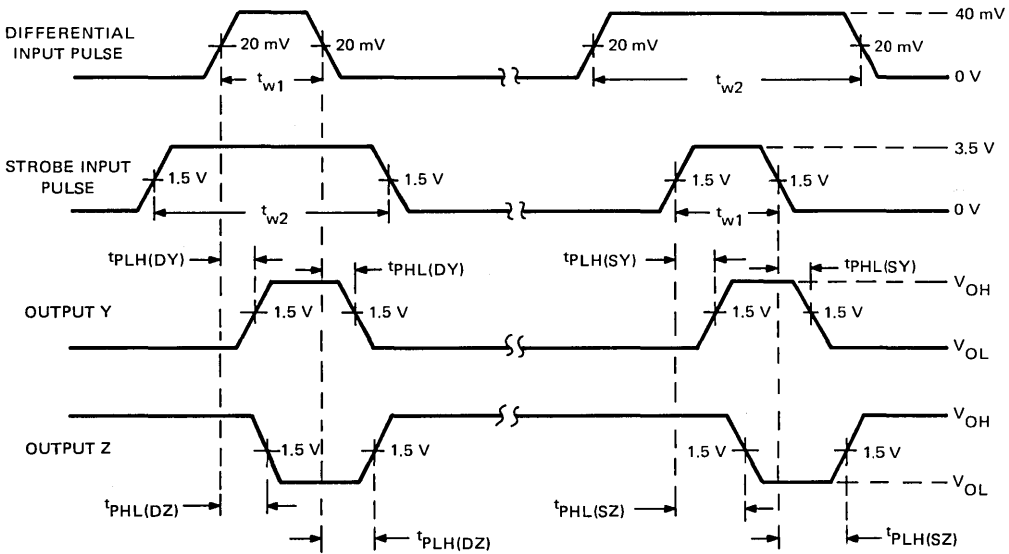

VOLTAGE WAVEFORMS

- NOTES: A. The pulse generators have the following characteristics:  $Z_{out} = 50 \Omega$ ,  $t_r = 15 \pm 5 \text{ ns}$ ,  $t_f = 15 \pm 5 \text{ ns}$ ,  $t_{w1} = 100 \text{ ns}$ ,  $t_{w2} = 300 \text{ ns}$ , and  $\text{PRR} = 1 \text{ MHz}$ .
- B. The strobe input pulse is applied to Strobe  $S_A$  when inputs A1-A2 are being tested and to Strobe  $S_B$  when inputs B1-B2 are being tested.
- C.  $C_L$  includes probe and jig capacitance.

FIGURE 28—SN5520/SN7520 PROPAGATION DELAY TIMES FROM DIFFERENTIAL AND STROBE INPUTS

6

# SERIES 5520/7520 SENSE AMPLIFIERS

## PARAMETER MEASUREMENT INFORMATION

switching characteristics (continued)

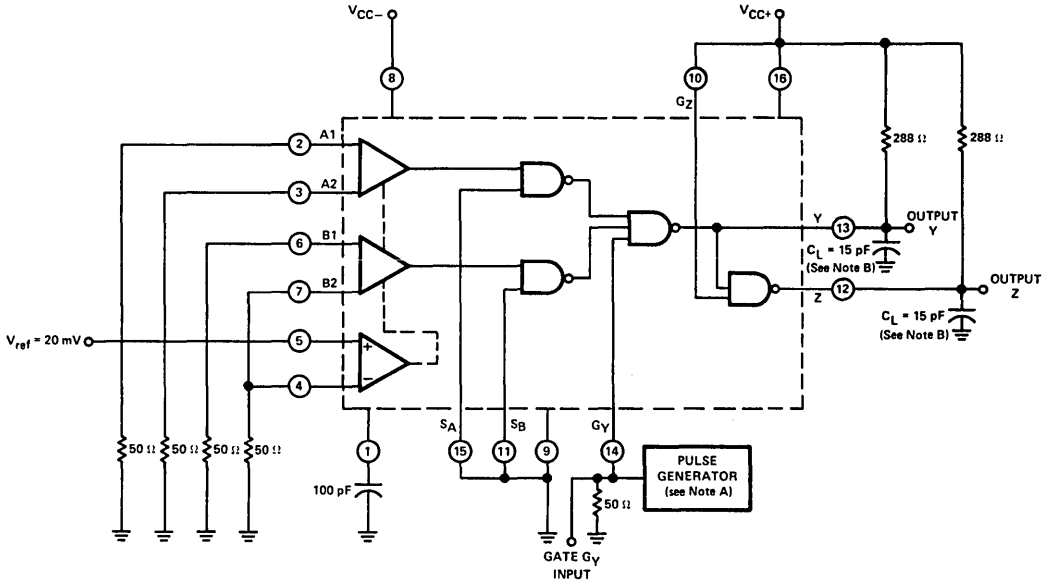

TEST CIRCUIT

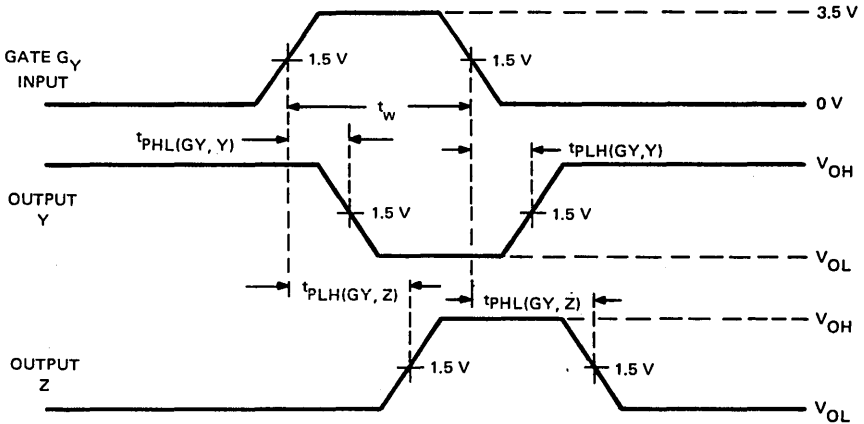

VOLTAGE WAVEFORMS

- NOTES: A. The pulse generator has the following characteristics:  $Z_{out} = 50 \Omega$ ,  $t_r = 15 \pm 5 \text{ ns}$ ,  $t_f = 15 \pm 5 \text{ ns}$ ,  $t_w = 100 \text{ ns}$ , and  $PRR = 1 \text{ MHz}$ .  
B.  $C_L$  includes probe and jig capacitance.

FIGURE 29—SN5520/SN7520 PROPAGATION DELAY TIMES FROM GATE  $G_Y$

# SERIES 5520/7520 SENSE AMPLIFIERS

## PARAMETER MEASUREMENT INFORMATION

switching characteristics (continued)

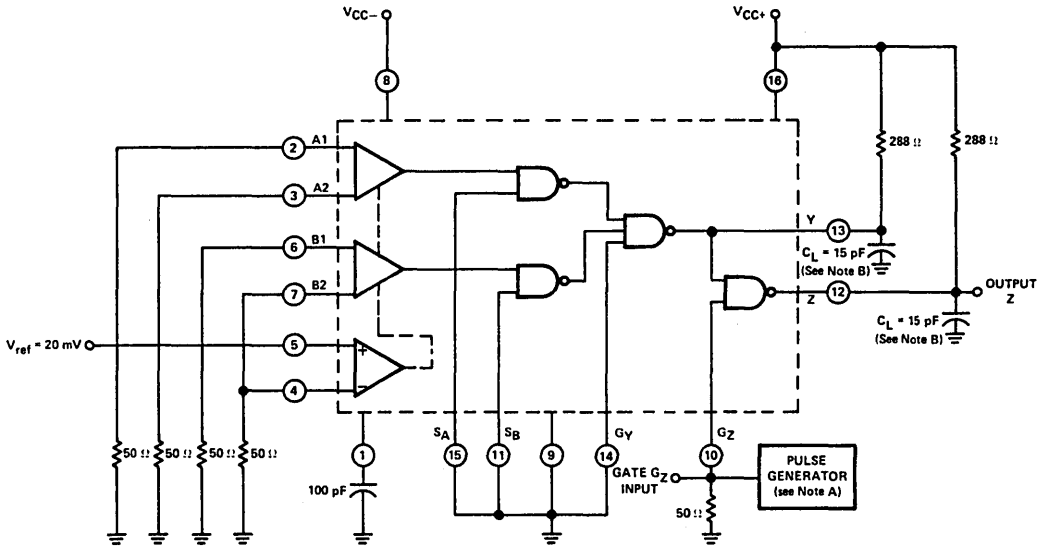

TEST CIRCUIT

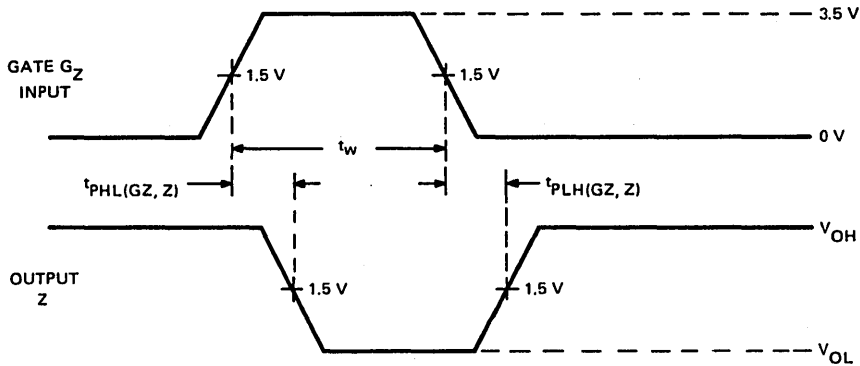

VOLTAGE WAVEFORMS

- NOTES: A. The pulse generator has the following characteristics:  $Z_{out} = 50 \Omega$ ,  $t_r = 15 \pm 5 \text{ ns}$ ,  $t_f = 15 \pm 5 \text{ ns}$ ,  $t_w = 100 \text{ ns}$ , and  $PRR = 1 \text{ MHz}$ .  
B.  $C_L$  includes probe and jig capacitance.

FIGURE 30—SN5520/SN7520 PROPAGATION DELAY TIMES FROM GATE  $G_Z$

# SERIES 5520/7520 SENSE AMPLIFIERS

## PARAMETER MEASUREMENT INFORMATION

switching characteristics (continued)

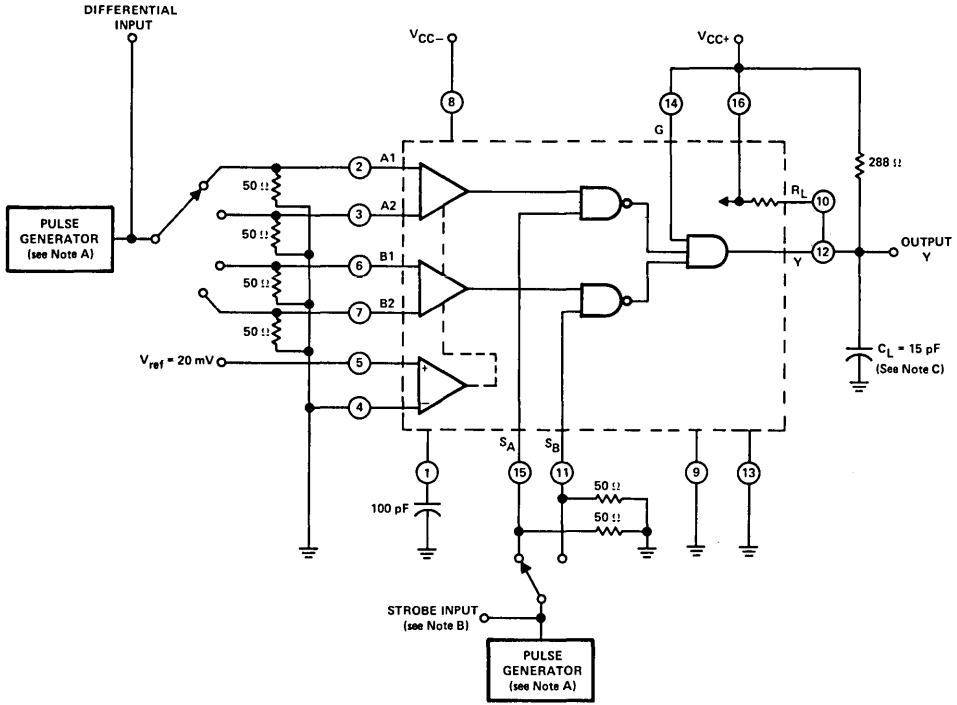

TEST CIRCUIT

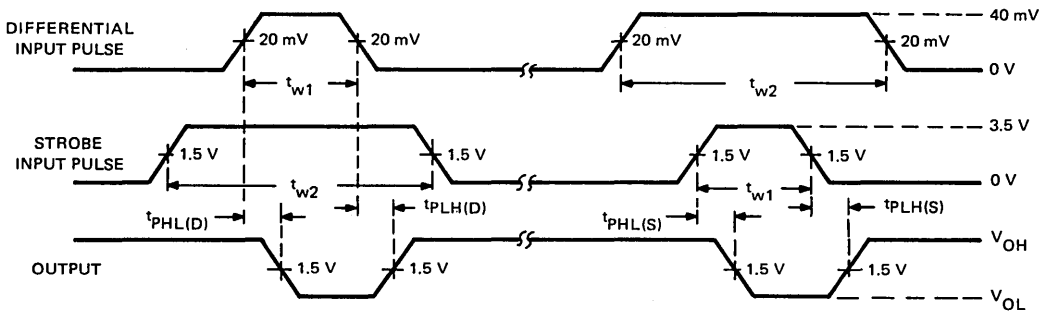

- NOTES: A. The pulse generators have the following characteristics:  $Z_{out} = 50 \Omega$ ,  $t_r = t_f = 15 \pm 5 \text{ ns}$ ,  $t_{w1} = 100 \text{ ns}$ ,  $t_{w2} = 300 \text{ ns}$ ,  $\text{PRR} = 1 \text{ MHz}$ .  
 B. The strobe input pulse is applied to Strobe  $S_A$  when testing inputs A1-A2 and to Strobe  $S_B$  when testing inputs B1-B2.  
 C.  $C_L$  includes probe and jig capacitance.

FIGURE 31—SN5522/SN7522 PROPAGATION DELAY TIMES FROM DIFFERENTIAL AND STROBE INPUTS

# SERIES 5620/7620 SENSE AMPLIFIERS

## PARAMETER MEASUREMENT INFORMATION

switching characteristics (continued)

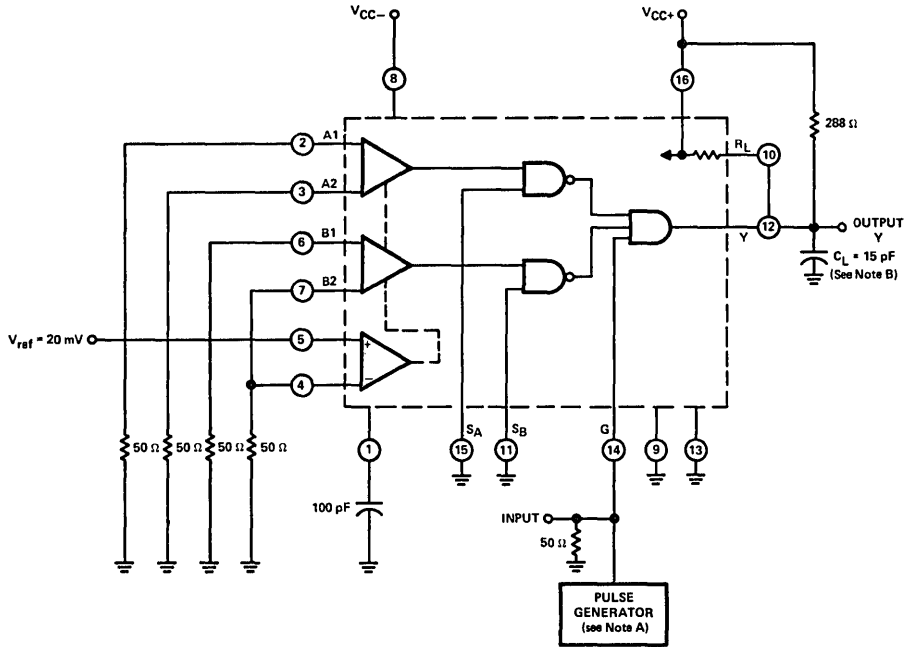

TEST CIRCUIT

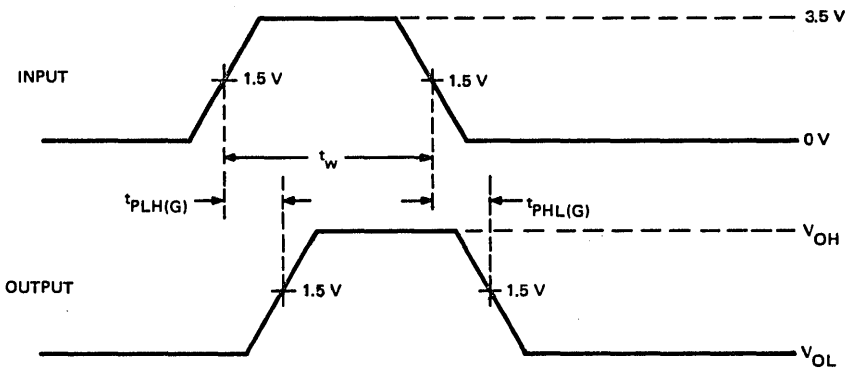

VOLTAGE WAVEFORMS

NOTES: A. The pulse generator has the following characteristics:  $Z_{out} = 50 \Omega$ ,  $t_r = 15 \pm 5 \text{ ns}$ ,  $t_f = 15 \pm 5 \text{ ns}$ ,  $t_w = 100 \text{ ns}$ , and  $PRR = 1 \text{ MHz}$ .  
 B.  $C_L$  includes probe and jig capacitance.

FIGURE 32—SN5522/SN7522 PROPAGATION DELAY TIMES FROM GATE INPUT

# SERIES 5520/7520 SENSE AMPLIFIERS

## PARAMETER MEASUREMENT INFORMATION

switching characteristics (continued)

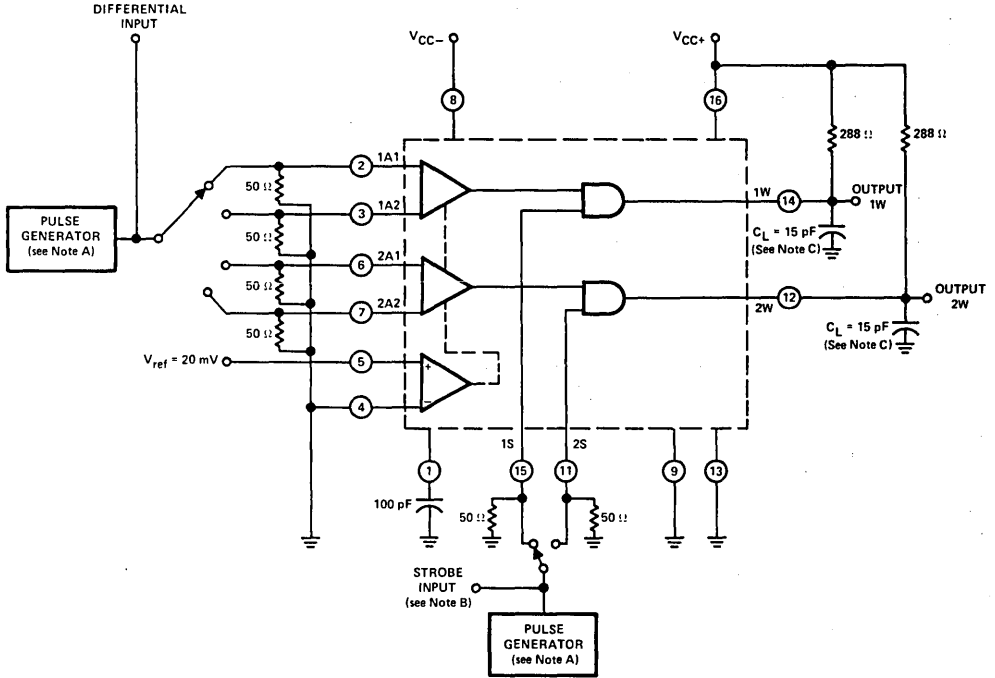

TEST CIRCUIT

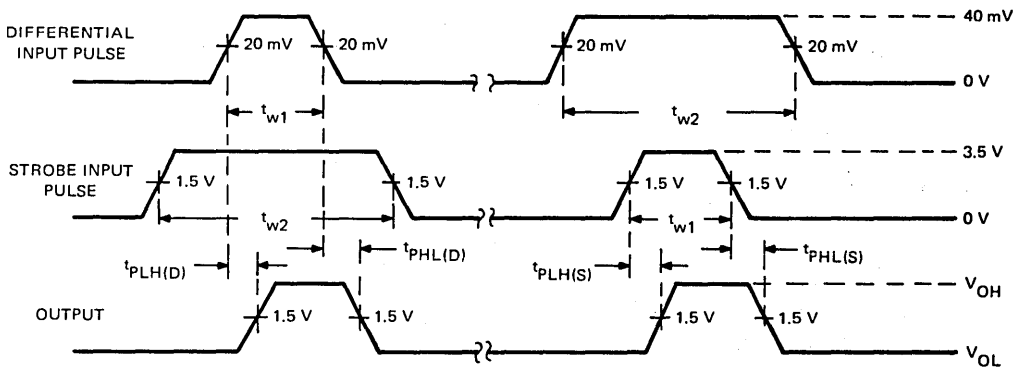

VOLTAGE WAVEFORMS

- NOTES: A. The pulse generators have the following characteristics:  $Z_{out} = 50 \Omega$ ,  $t_r = 15 \pm 5 \text{ ns}$ ,  $t_f = 15 \pm 5 \text{ ns}$ ,  $t_{w1} = 100 \text{ ns}$ ,  $t_{w2} = 300 \text{ ns}$ , and  $\text{PRR} = 1 \text{ MHz}$ .
- B. The strobe input pulse is applied to Strobe 1S when inputs 1A1-1A2 are being tested and to Strobe 2S when inputs 2A1-2A2 are being tested.
- C.  $C_L$  includes probe and jig capacitance.

FIGURE 33—SN5524/SN7524 PROPAGATION DELAY TIMES



# SERIES 5520/7520 SENSE AMPLIFIERS

## PARAMETER MEASUREMENT INFORMATION

switching characteristics (continued)

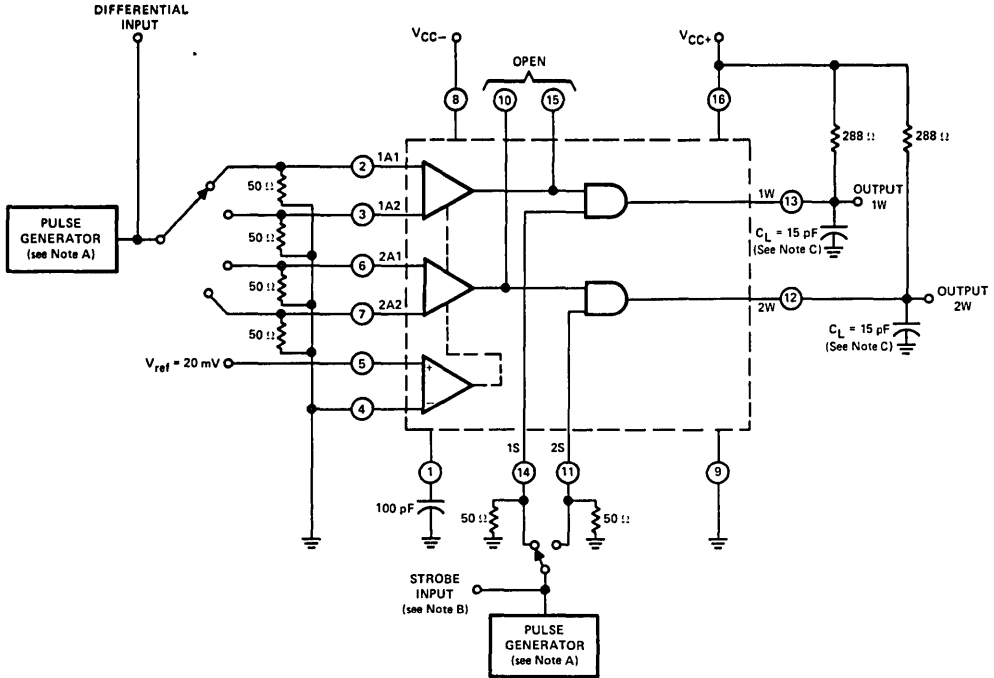

TEST CIRCUIT

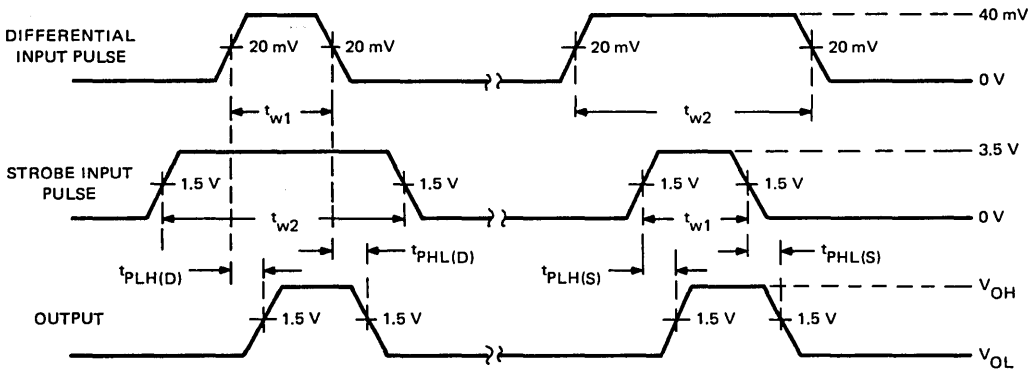

VOLTAGE WAVEFORMS

- NOTES: A. The pulse generators have the following characteristics:  $Z_{out} = 50 \Omega$ ,  $t_r = 15 \pm 5 \text{ ns}$ ,  $t_f = 15 \pm 5 \text{ ns}$ ,  $t_{w1} = 100 \text{ ns}$ ,  $t_{w2} = 300 \text{ ns}$ , and  $\text{PRR} = 1 \text{ MHz}$ .
- B. The strobe input pulse is applied to Strobe 1S when inputs 1A1-1A2 are being tested and to Strobe 2S when inputs 2A1-2S2 are being tested.
- C.  $C_L$  includes probe and jig capacitance.

FIGURE 34—SN5528/SN7528 PROPAGATION DELAY TIMES

# SERIES 5520/7520 SENSE AMPLIFIERS

## PARAMETER MEASUREMENT INFORMATION

switching characteristics (continued)

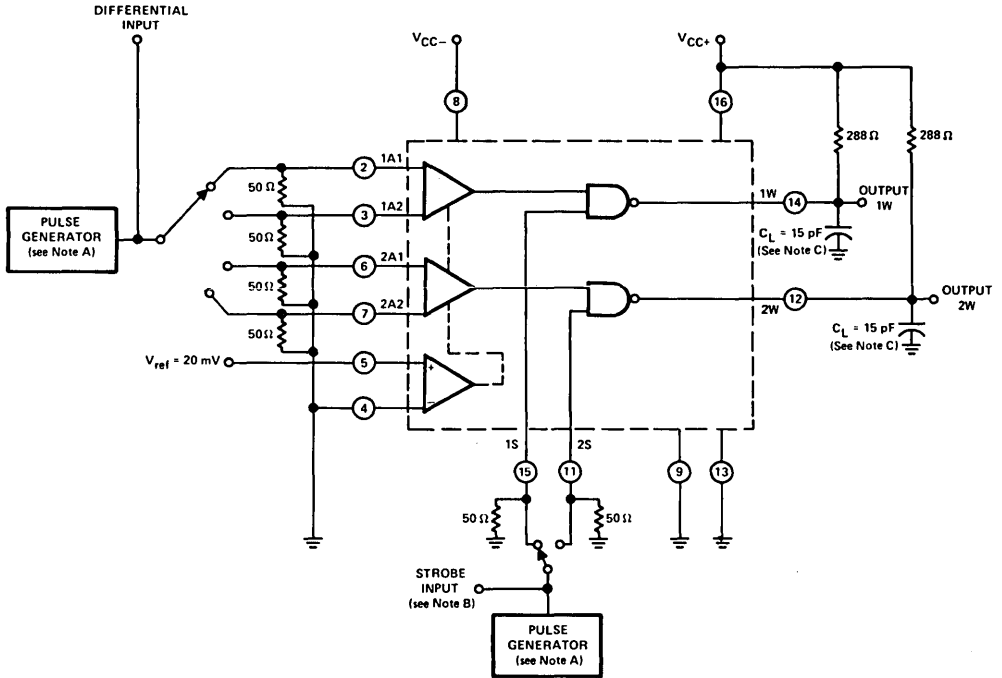

TEST CIRCUIT

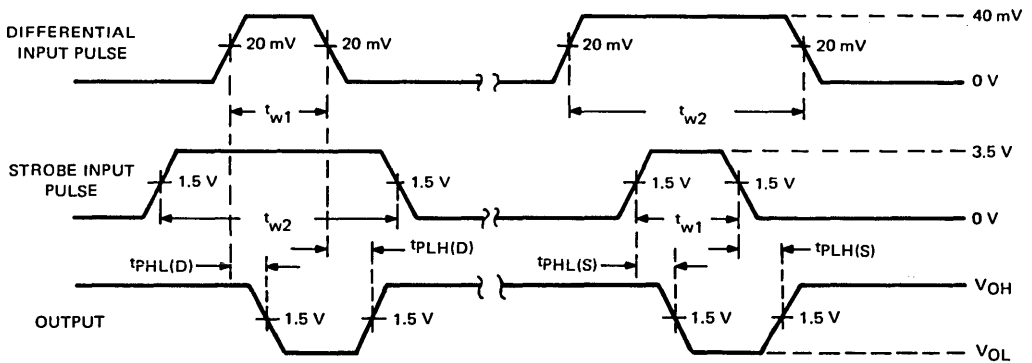

VOLTAGE WAVEFORMS

- NOTES: A. The pulse generators have the following characteristics:  $Z_{out} = 50 \Omega$ ,  $t_r = 15 \pm 5 \text{ ns}$ ,  $t_f = 15 \pm 5 \text{ ns}$ ,  $t_{w1} = 100 \text{ ns}$ ,  $t_{w2} = 300 \text{ ns}$ , and  $PRR = 1 \text{ MHz}$ .
- B. The strobe input pulse is applied to Strobe 1S when inputs 1A1-1A2 are being tested and to Strobe 2S when inputs 2A1-2A2 are being tested.
- C.  $C_L$  includes probe and jig capacitance.

FIGURE 35—SN55232, SN75232, SN55234, and SN75234 PROPAGATION DELAY TIMES

# SERIES 5520/7520 SENSE AMPLIFIERS

## PARAMETER MEASUREMENT INFORMATION

### switching characteristics (continued)

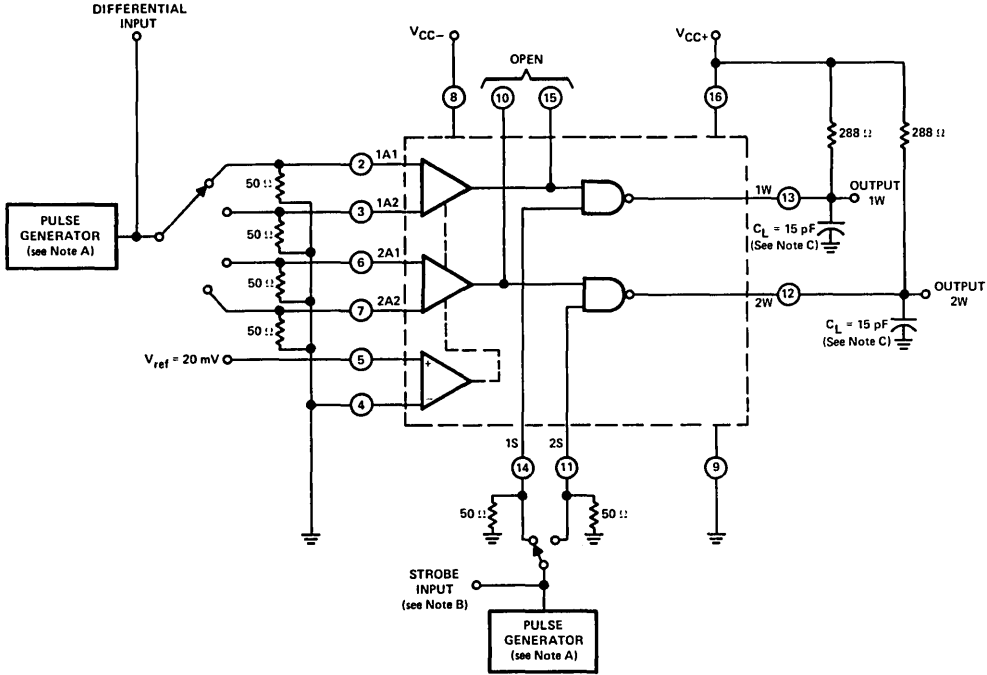

TEST CIRCUIT

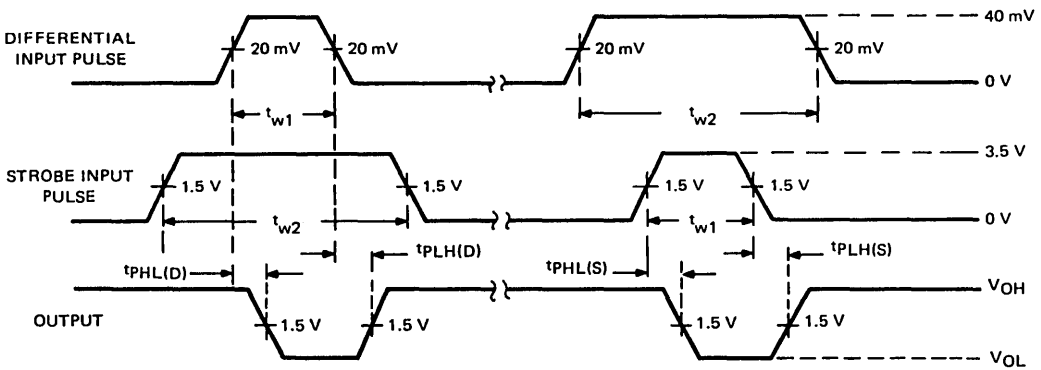

VOLTAGE WAVEFORMS

- NOTES: A. The pulse generators have the following characteristics:  $Z_{out} = 50\ \Omega$ ,  $t_r = 15 \pm 5\text{ ns}$ ,  $t_f = 15 \pm 5\text{ ns}$ ,  $t_{w1} = 100\text{ ns}$ ,  $t_{w2} = 300\text{ ns}$ , and  $PRR = 1\text{ MHz}$ .  
 B. The strobe input pulse is applied to Strobe 1S when inputs 1A1-1A2 are being tested and to Strobe 2S when inputs 2A1-2S2 are being tested.  
 C.  $C_L$  includes probe and jig capacitance.

FIGURE 36—SN55238/SN75238 PROPAGATION DELAY TIMES

# SERIES 5520/7520 SENSE AMPLIFIERS

## TYPICAL CHARACTERISTICS

THRESHOLD VOLTAGE  
vs  
REFERENCE VOLTAGE

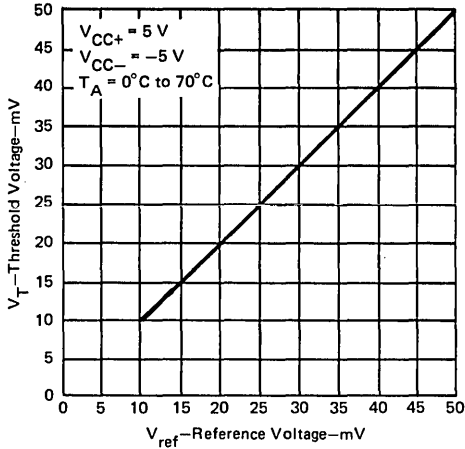

FIGURE 37

THRESHOLD VOLTAGE  
vs  
SUPPLY VOLTAGE

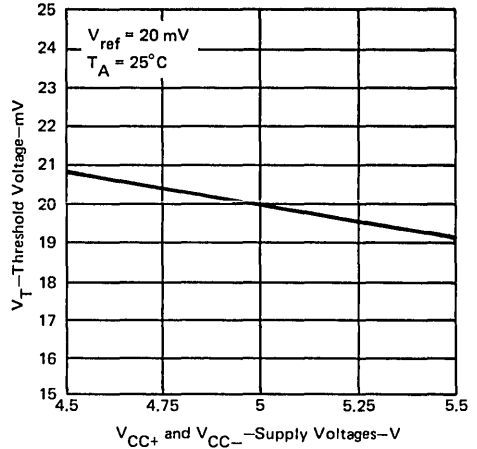

FIGURE 38

NORMALIZED THRESHOLD VOLTAGE  
vs  
PULSE REPETITION RATE

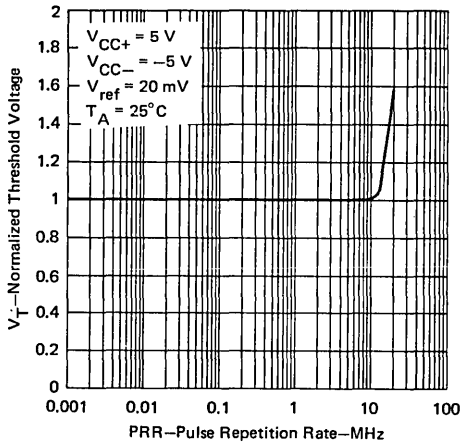

FIGURE 39

COMMON-MODE FIRING VOLTAGE  
vs  
FREE-AIR TEMPERATURE

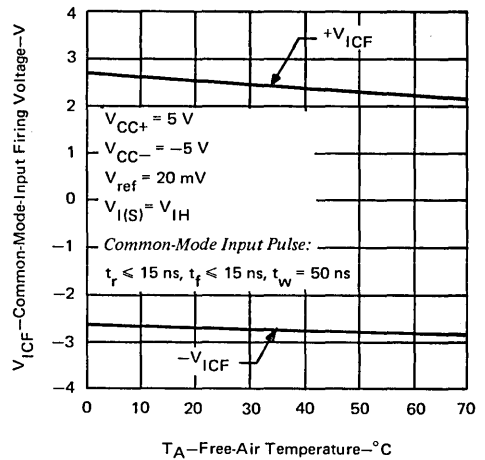

FIGURE 40

# SERIES 5520/7520 SENSE AMPLIFIERS

## TYPICAL CHARACTERISTICS

DIFFERENTIAL-INPUT BIAS CURRENT  
vs  
FREE-AIR TEMPERATURE

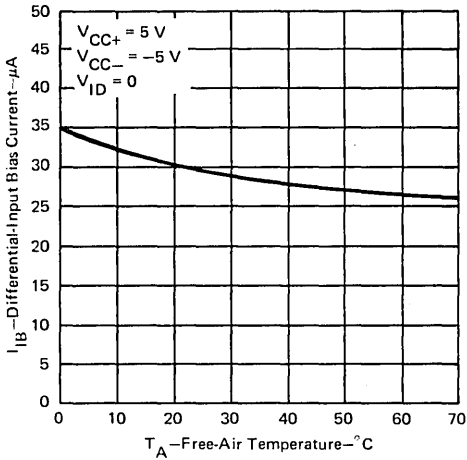

FIGURE 41

DIFFERENTIAL-INPUT OFFSET CURRENT  
vs  
FREE-AIR TEMPERATURE

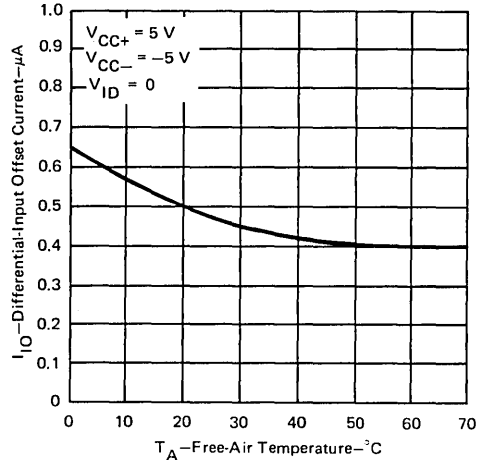

FIGURE 42

HIGH-LEVEL INPUT CURRENT  
vs  
INPUT VOLTAGE

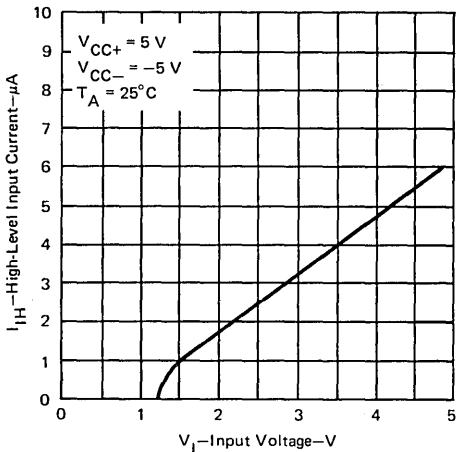

FIGURE 43

LOW-LEVEL INPUT CURRENT  
vs  
INPUT VOLTAGE

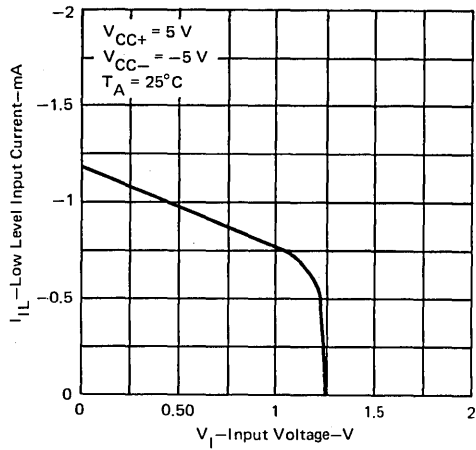

FIGURE 44

# SERIES 5520/7520 SENSE AMPLIFIERS

## TYPICAL CHARACTERISTICS

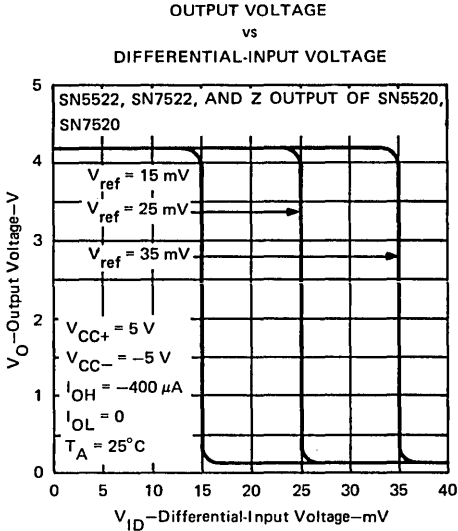

FIGURE 45

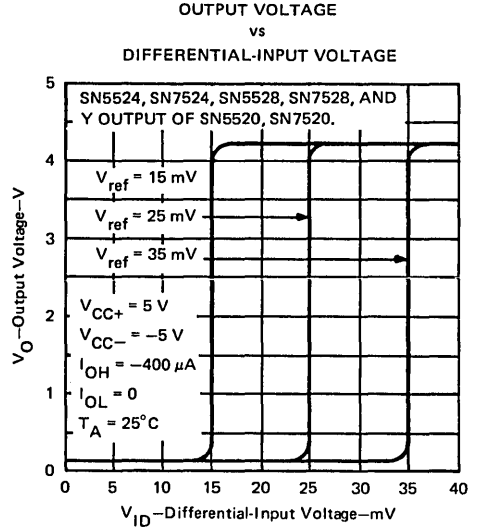

FIGURE 46

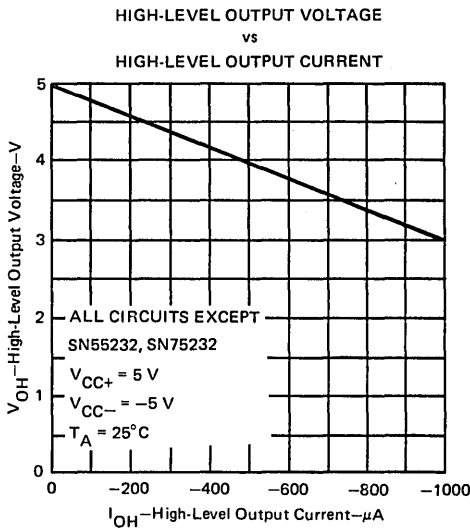

FIGURE 47

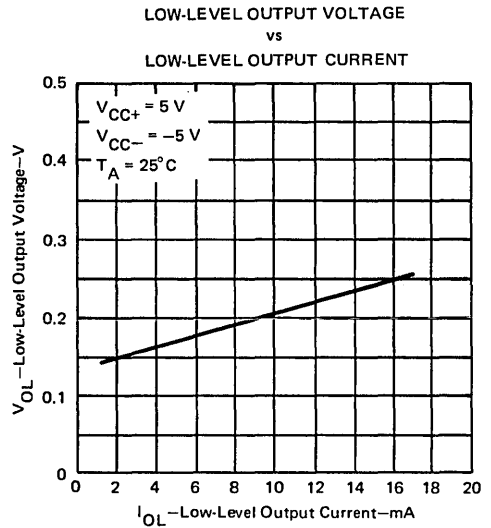

FIGURE 48

## APPLICATION DATA

### combined fan-out and wire-AND capabilities

The open-collector TTL gate, when supplied with a proper load resistor ( $R_L$ ), may be paralleled with other similar TTL gates to perform the wire-AND function, and simultaneously, will drive from one to nine Series 54/74 loads. When no other open-collector gates are paralleled, this gate may be used to drive ten Series 54/74 loads. For any of these conditions an appropriate load resistor value must be determined for the desired circuit configuration. A maximum resistor value must be determined which will ensure that sufficient load current (to TTL loads) and off current (through paralleled outputs) will be available while the output is high. A minimum resistor value must be determined which will ensure that current through this resistor and sink current from the TTL loads will not cause the output voltage to rise above the low level even if one of the paralleled outputs is sinking all the current.

In both conditions (low and high level) the value of  $R_L$  is determined by:

$$R_L = \frac{V_{RL}}{I_{RL}}$$

where  $V_{RL}$  is the voltage drop in volts, and  $I_{RL}$  is the current in amperes.

### high-level (off-state) circuit calculations (see figure 49)

The allowable voltage drop across the load resistor ( $V_{RL}$ ) is the difference between  $V_{CC}$  applied and the  $V_{OH}$  level required at the load:

$$V_{RL} = V_{CC} - V_{OH \text{ min}}$$

The total current through the load resistor ( $I_{RL}$ ) is the sum of the load currents ( $I_{IH}$ ) and off-state reverse currents ( $I_{OH}$ ) through each of the wire-AND-connected outputs:

$$I_{RL} = \eta \cdot I_{OH} + N \cdot I_{IH} \text{ to TTL loads}$$

Therefore, calculations for the maximum value of  $R_L$  would be:

$$R_{L(\text{max})} = \frac{V_{CC} - V_{OH \text{ min}}}{\eta \cdot I_{OH} + N \cdot I_{IH}}$$

where  $\eta$  = number of gates wire-AND-connected, and  $N$  = number of TTL loads.

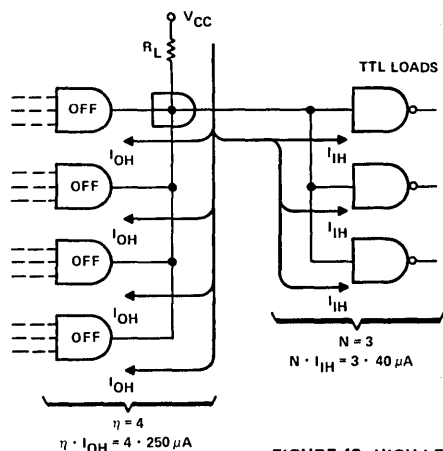

Calculation:

$$R_{L(\text{max})} = \frac{V_{CC} - V_{OH \text{ min}}}{\eta \cdot I_{OH} + N \cdot I_{IH}}$$

$$R_{L(\text{max})} = \frac{5 - 2.4}{0.001 + 0.00012} \Omega = \frac{2.6}{0.00112} \Omega = 2321 \Omega$$

FIGURE 49—HIGH-LEVEL CIRCUIT CONDITIONS

# SERIES 5520/7520 SENSE AMPLIFIERS

## APPLICATION DATA

### low-level (on-state) circuit calculations (see figure 50)

The current through the resistor must be limited to the maximum sink-current of one output transistor. Note that if several output transistors are wire-AND connected, the current through  $R_L$  may be shared by those paralleled transistors. However, unless it can be absolutely guaranteed that more than one transistor will be on during low-level periods, the current must be limited to 16 mA, the maximum current which will ensure a low-level maximum of 0.4 volt.

Also, fan-out must be considered. Part of the 16 mA will be supplied from the inputs which are being driven. This reduces the amount of current which can be allowed through  $R_L$ .

Therefore, the equation used to determine the minimum value of  $R_L$  would be:

$$R_L(\text{min}) = \frac{V_{CC} - V_{OL \text{ max}}}{I_{OL \text{ capability}} - N \cdot I_{IL}}$$

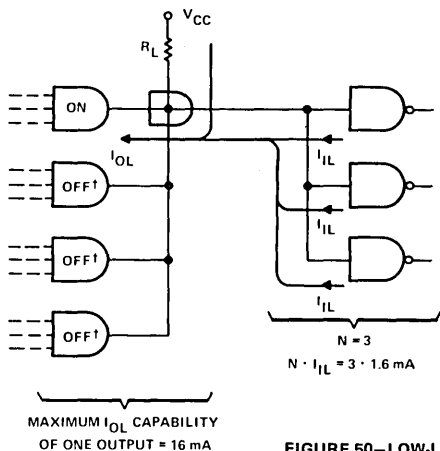

Calculation:

$$R_L(\text{min}) = \frac{V_{CC} - V_{OL \text{ max}}}{I_{OL \text{ capability}} - N \cdot I_{OL}}$$

$$R_L(\text{min}) = \frac{5 - 0.4}{0.016 - 0.0048} \Omega = \frac{4.6}{0.0112} \Omega = 410 \Omega$$

†Current into OFF outputs is negligible at the low logic level.

FIGURE 50—LOW-LEVEL CIRCUIT CONDITIONS

### driving series 54/74 loads and combining outputs

Table 1 provides minimum and maximum resistor values, calculated from equations shown above, for driving one to ten Series 54/74 loads and wire-AND connecting two to seven parallel outputs. Each value shown for one wire-AND output is determined by the fan-out plus the cutoff current of a single output transistor. Extension beyond seven wire-AND connections is permitted with fan-outs of seven or less if a valid minimum and maximum  $R_L$  is possible. When fanning-out to ten Series 54/74 loads, the calculation for the minimum value of  $R_L$  indicates that an infinite resistance should be used ( $V_{RL} \div 0 = \infty$ ); however, the use of a 4-k $\Omega$  resistor in this case will satisfy the high-level condition and limit the low level to less than 0.43 volt.

TABLE 1

FAN-OUT TO TTL LOADS	WIRE-AND OUTPUTS							
	1	2	3	4	5	6	7	1 to 7
1	8965	4814	3291	2500	2015	1688	1452	319
2	7878	4482	3132	2407	1954	1645	1420	359
3	7027	4193	2988	2321	1897	1604	1390	410
4	6341	3939	2857	2241	1843	1566	1361	479
5	5777	3714	2736	2166	1793	1529	1333	575
6	5306	3513	2626	2096	1744	1494	1306	718
7	4905	3333	2524	2031	1699	1460	1260	958
8	4561	3170	2429	1969	1656	X	X	1437
9	4262	3023	X	X	X	X	X	2875
10	4000	X	X	X	X	X	X	4000§
MAXIMUM								MIN
LOAD RESISTOR VALUE IN OHMS								

†—All values shown in the table are based on:

High-level conditions:  $V_{CC} = 5 \text{ V}$ ,  $V_{OH \text{ min}} = 2.4 \text{ V}$

Low-level conditions:  $V_{CC} = 5 \text{ V}$ ,  $V_{OL \text{ max}} = 0.4 \text{ V}$

X—Not recommended or not possible.

§—The theoretical value is  $\infty$ . See explanation in text.



# SERIES 5520/7520 SENSE AMPLIFIERS

## TYPICAL APPLICATIONS

### small memory systems

This application demonstrates an improved method of sensing data from relatively small memory systems. Two individual core planes, usually consisting of 4096 cores each, can be interfaced by each of the dual-channel SN5524 or SN7524 sense amplifiers, see Figure 51. Standard TTL or DTL integrated circuits, driven directly from the compatible sense-amplifier outputs, may be selected to serve as the memory data register (MDR).

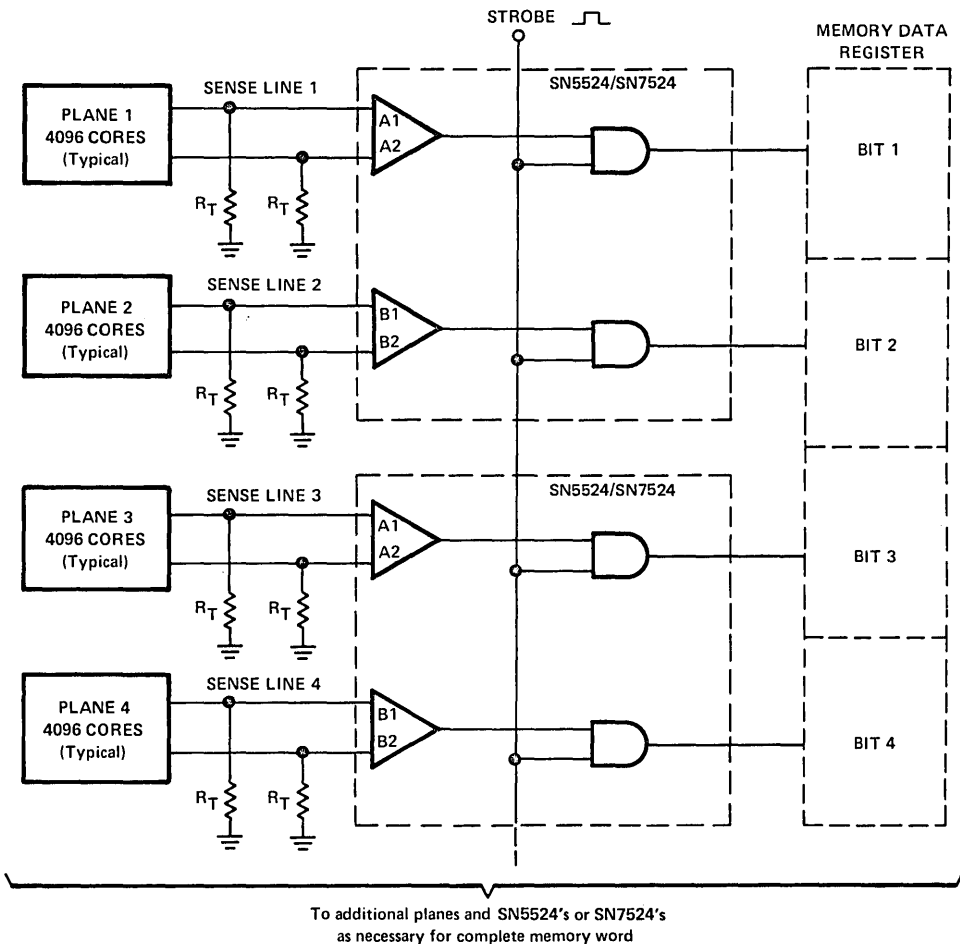

FIGURE 51—SENSING SMALL MEMORY SYSTEMS

# SERIES 5520/7520 SENSE AMPLIFIERS

## TYPICAL APPLICATIONS (continued)

### large memory systems

This application demonstrates an improved method of sensing data from large memory systems. The signal-to-noise ratio can be increased by sectioning the large core planes as illustrated in Figure 52. Two segments, usually consisting of 4096 cores each, can be interfaced by each of the dual-input channels of the SN5520/SN7520 or SN5522/SN7522 sense amplifiers. The cascaded output gates of the SN5520/SN7520 circuits may be connected to serve as the memory data register (MDR). A number of SN5522/SN7522 sense amplifiers may be wire-AND connected to expand the input function of the MDR to interface all the segments of the plane. Complementary outputs, clear, and preset functions are provided for the MDR. Rules for combined fan-out and wire-AND capabilities must be observed.

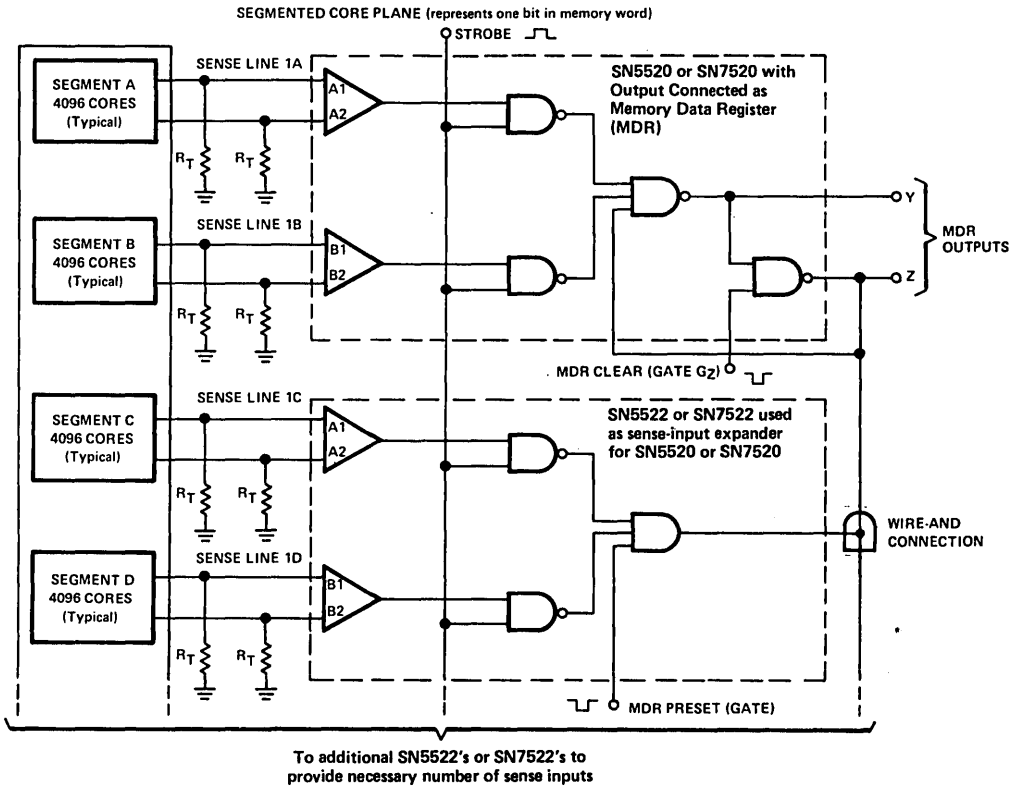

FIGURE 52—SENSING LARGE MEMORY SYSTEMS

# INTERFACE CIRCUITS

## TYPES SN75207, SN75207B, SN75208, SN75208B DUAL SENSE AMPLIFIERS FOR MOS MEMORIES OR DUAL HIGH-SENSITIVITY LINE RECEIVERS

BULLETIN NO. DL-S 11793, JULY 1973—REVISED JANUARY 1977

- Plug-in Replacement for SN75107A, SN75107B, SN75108A, SN75108B with Improved Characteristics
- $\pm 10$  mV Guaranteed Input Sensitivity
- TTL Compatible
- Standard Supply Voltages . . .  $\pm 5$  V
- Differential Input Common-Mode Voltage Range of  $\pm 3$  V
- Strobe Inputs for Channel Selection
- '207 and '207B Have Totem-Pole Outputs
- '208 and '208B Have Open-Collector Outputs
- "B" Versions Have Diode-Protected Input Stage for Power-Off Condition
- Sense Amplifier for MOS Memories
- Dual Comparator
- High-Sensitivity Line Receiver

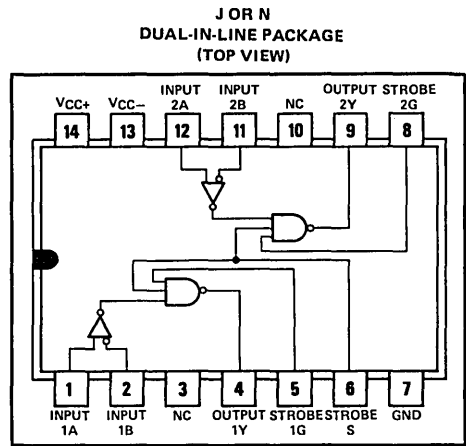

NC—No internal connection

### description

The SN75207, SN75207B, SN75208, and SN75208B are pin-for-pin replacements for the SN75107A, SN75107B, SN75108A, and SN75108B, respectively. The improved input sensitivity makes them more suitable for MOS memory sense amplifiers and can result in faster memory cycles. Improved sensitivity also makes them more useful in line receiver applications by allowing use of longer transmission line lengths. The '207 and '207B each features a TTL-compatible active-pull-up output. The '208 and '208B each features an open-collector output that permits wired-AND logic connections with similar output configurations. These devices are designed for operation from 0°C to 70°C and are available in the ceramic dual-in-line (J) package or in the plastic dual-in-line (N) package.

6

FUNCTION TABLE

DIFFERENTIAL INPUTS A-B	STROBES		OUTPUT Y
	G	S	
$V_{ID} > 10$ mV	X	X	H
$-10$ mV $< V_{ID} < 10$ mV	X	L	H
	L	X	H
$V_{ID} < -10$ mV	H	H	Indeterminate
	X	L	H
	L	X	H
	H	H	L

H = high level, L = low level, X = irrelevant

The essential difference between the un-suffixed and "B" versions can be seen in the schematics. Input-protection diodes are in series with the collectors of the differential-input transistors of the "B" versions. These diodes are useful in certain "party-line" systems that may have multiple  $V_{CC+}$  power supplies and may be operated with some of the  $V_{CC+}$  supplies turned off. In such a system, if a supply is turned off and allowed to go to ground, the equivalent input circuit connected to that supply would be as follows:



This would be a problem in specific systems that might possibly have the transmission lines biased to some potential greater than 1.4 volts.

**TEXAS INSTRUMENTS**  
INCORPORATED

POST OFFICE BOX 225012 • DALLAS, TEXAS 75265

# TYPES SN75207, SN75207B, SN75208, SN75208B DUAL SENSE AMPLIFIERS FOR MOS MEMORIES OR DUAL HIGH-SENSITIVITY LINE RECEIVERS

## design characteristics

The '207, '207B, '208, and '208B line receivers/sense amplifiers are TTL-compatible dual circuits intended for use in high-speed data-transmission systems or MOS memory systems. They are designed to detect low-level differential signals in the presence of common-mode noise and variations of temperature and supplies. Dc specifications reflect worst-case conditions of temperature, supply voltages, and input voltages.

The input common-mode voltage range is  $\pm 3$  volts. This is adequate for application in most systems. In systems with requirements for greater common-mode voltage range, input attenuators may be used to decrease the noise to an acceptable level at the receiver-input terminals.

The circuits feature individual strobe inputs for each channel and a strobe input common to both channels for logic versatility. The strobe inputs are tested to guarantee 400 millivolts of dc noise margin when interfaced with Series 54/74 TTL.

The circuits feature high input impedance and low input currents, which induce very little loading on the transmission line. This makes these devices especially useful in party-line systems. The excellent input sensitivity (3 millivolts typical) is particularly important when data is to be detected at the end of a long transmission line and the amplitude of the data has deteriorated due to cable losses. The circuits are designed to detect input signals of 10 millivolts (or greater) amplitude and convert the polarity of the signal into appropriate TTL-compatible output logic levels.

## schematic (each receiver)

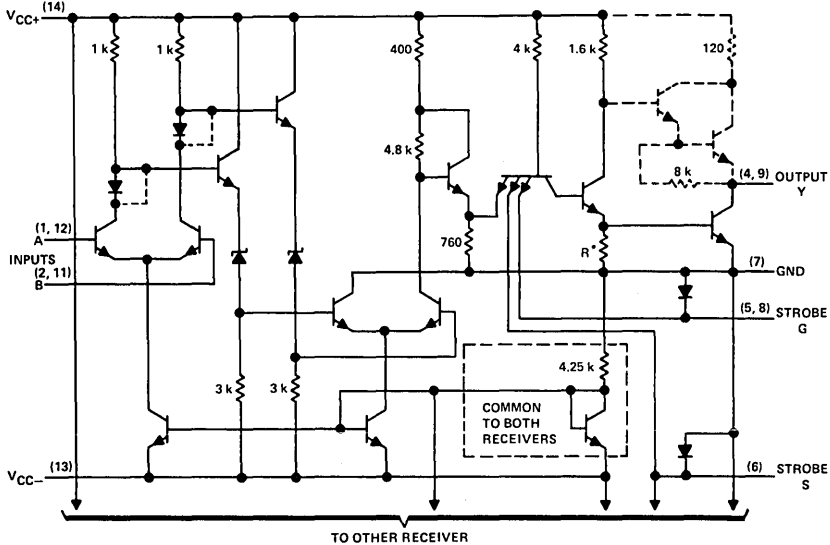

\*  $R = 1 \text{ k}\Omega$  for '207 and '207B,  $750 \Omega$  for '208 and '208B.

NOTES: A. Resistor values shown are nominal and in ohms.

B. Components shown with dashed lines in the output circuitry are applicable to the '207 and '207B only. Diodes in series with the collectors of the differential input transistors are short-circuited on '207 and '208.

# TYPES SN75207, SN75207B, SN75208, SN75208B

## DUAL SENSE AMPLIFIERS FOR MOS MEMORIES OR DUAL HIGH-SENSITIVITY LINE RECEIVERS

absolute maximum ratings over operating free-air temperature range (unless otherwise noted)

Supply voltage $V_{CC+}$ (see Note 1)	7 V
Supply voltage $V_{CC-}$	-7 V
Differential input voltage (see Note 2)	$\pm 6$ V
Common-mode input voltage (see Note 3)	$\pm 5$ V
Strobe input voltage	5.5 V
Continuous total dissipation	600 mW
Operating free-air temperature range	$0^{\circ}\text{C}$ to $70^{\circ}\text{C}$
Storage temperature range	$-65^{\circ}\text{C}$ to $150^{\circ}\text{C}$

recommended operating conditions (see note 4)

	MIN	NOM	MAX	UNIT
Supply voltage $V_{CC+}$	4.75	5	5.25	V
Supply voltage $V_{CC-}$	-4.75	-5	-5.25	V
Low-level output current, $I_{OL}$			-16	mA
Differential input voltage, $V_{ID}$ (see Note 5)	-5 <sup>†</sup>		5	V
Common-mode input voltage, $V_{IC}$ (see Notes 5 and 6)	-3 <sup>†</sup>		3	V
Input voltage range, any differential input to ground (see Note 5)	-5 <sup>†</sup>		3	V
Operating free-air temperature, $T_A$	0		70	$^{\circ}\text{C}$

<sup>†</sup>The algebraic convention, where the less positive (more negative) limit is designated as minimum, is used in this data sheet for logic voltage levels only.

- NOTES:
- All voltage values, except differential voltages, are with respect to network ground terminal.
  - Differential voltage values are at the noninverting (A) terminal with respect to the inverting (B) terminal.
  - Common-mode input voltage is the average of the voltages at the A and B inputs.
  - When using only one channel of the line receiver, the strobe G of the unused channel should be grounded and at least one of the differential inputs of the unused receiver should be terminated at some voltage between -3 V and 3 V.
  - The recommended combinations of input voltages fall within the shaded area of the figure at the right.
  - The common-mode voltage may be as low as -4 V provided that the more positive of the two inputs is not more negative than -3 V.

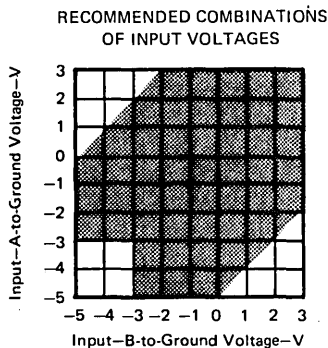

# TYPES SN75207, SN75207B, SN75208, SN75208B DUAL SENSE AMPLIFIERS FOR MOS MEMORIES OR DUAL HIGH-SENSITIVITY LINE RECEIVERS

## definition of input logic levels†

		MIN	MAX	UNIT
$V_{IDH}$	High-level input voltage between differential inputs	0.01	5	V
$V_{IDL}$	Low-level input voltage between differential inputs	-5	-0.01	V
$V_{IH(S)}$	High-level input voltage at strobe inputs	2	5.5	V
$V_{IL(S)}$	Low-level input voltage at strobe inputs	0	0.8	V

†The algebraic convention, where the more positive (less negative) limit is designated maximum, is used in this data sheet with logic input voltage levels only.

## electrical characteristics over recommended free-air temperature range (unless otherwise noted)

PARAMETER		TEST CONDITIONS‡		'207, '207B		'208, '208B		UNIT	
				MIN	TYP§ MAX	MIN	TYP§ MAX		
$I_{IH}$	High-level input current	A	$V_{CC±} = \text{MAX}$	$V_{ID} = 5 \text{ V}$	30	75	30	75	$\mu\text{A}$
		B		$V_{ID} = -5 \text{ V}$	30	75	30	75	
$I_{IL}$	Low-level input current	A	$V_{CC±} = \text{MAX}$	$V_{ID} = -5 \text{ V}$			-10	-10	$\mu\text{A}$
		B		$V_{ID} = 5 \text{ V}$			-10	-10	
$I_{IH}$	High-level input current into 1G or 2G	$V_{CC±} = \text{MAX}, V_{IH(S)} = 2.4 \text{ V}$					40	40	$\mu\text{A}$
		$V_{CC±} = \text{MAX}, V_{IH(S)} = \text{MAX } V_{CC+}$					1	1	
$I_{IL}$	Low-level input current into 1G or 2G	$V_{CC±} = \text{MAX}, V_{IL(S)} = 0.4 \text{ V}$					-1.6	-1.6	mA
$I_{IH}$	High-level input current into S	$V_{CC±} = \text{MAX}, V_{IH(S)} = 2.4 \text{ V}$					80	80	$\mu\text{A}$
		$V_{CC±} = \text{MAX}, V_{IH(S)} = \text{MAX } V_{CC+}$					2	2	
$I_{IL}$	Low-level input current into S	$V_{CC±} = \text{MAX}, V_{IL(S)} = 0.4 \text{ V}$					-3.2	-3.2	mA
$V_{OH}$	High-level output voltage	$V_{CC±} = \text{MIN}, V_{IL(S)} = 0.8 \text{ V}, V_{OH} = -400 \mu\text{A}, V_{IC} = -3 \text{ V to } 3 \text{ V}$		$V_{IDH} = 10 \text{ mV}$	2.4				V
$V_{OL}$	Low-level output voltage	$V_{CC±} = \text{MIN}, V_{IH(S)} = 2 \text{ V}, V_{OL} = 16 \text{ mA}, V_{IC} = -3 \text{ V to } 3 \text{ V}$		$V_{IDL} = -10 \text{ mV}$			0.4	0.4	V
$I_{OH}$	High-level output current	$V_{CC±} = \text{MIN}, V_{OH} = \text{MAX } V_{CC+}$						250	$\mu\text{A}$
$I_{OS}$	Short-circuit output current¶	$V_{CC±} = \text{MAX}$			-18	-70			mA
$I_{CCH+}$	Supply current from $V_{CC+}$ , outputs high	$V_{CC±} = \text{MAX}, T_A = 25^\circ\text{C}$			18	30	18	30	mA
$I_{CCH-}$	Supply current from $V_{CC-}$ , outputs high	$V_{CC±} = \text{MAX}, T_A = 25^\circ\text{C}$			-8.4	-15	-8.4	-15	mA

‡For conditions shown as MIN or MAX, use the appropriate value specified under recommended operating conditions.

§ All typical values are at  $V_{CC+} = 5 \text{ V}, V_{CC-} = -5 \text{ V}, T_A = 25^\circ\text{C}$ .

¶ Not more than one output should be shorted at a time.

## switching characteristics, $V_{CC+} = 5 \text{ V}, V_{CC-} = -5 \text{ V}, T_A = 25^\circ\text{C}$

PARAMETER		TEST CONDITIONS		'207, '207B		'208, '208B		UNIT
				MIN	TYP MAX	MIN	TYP MAX	
$t_{PLH(D)}$	Propagation delay time, low-to-high-level output, from differential inputs A and B	$R_L = 470 \Omega, C_L = 15 \text{ pF},$ See Figure 1			35		35	ns
$t_{PHL(D)}$	Propagation delay time, high-to-low-level output, from differential inputs A and B				20		20	ns
$t_{PLH(S)}$	Propagation delay time, low-to-high-level output, from strobe input G or S				17		17	ns
$t_{PHL(S)}$	Propagation delay time, high-to-low-level output, from strobe input G or S				17		17	ns

# TYPES SN75207, SN75207B, SN75208, SN75208B DUAL SENSE AMPLIFIERS FOR MOS MEMORIES OR DUAL HIGH-SENSITIVITY LINE RECEIVERS

## PARAMETER MEASUREMENT INFORMATION

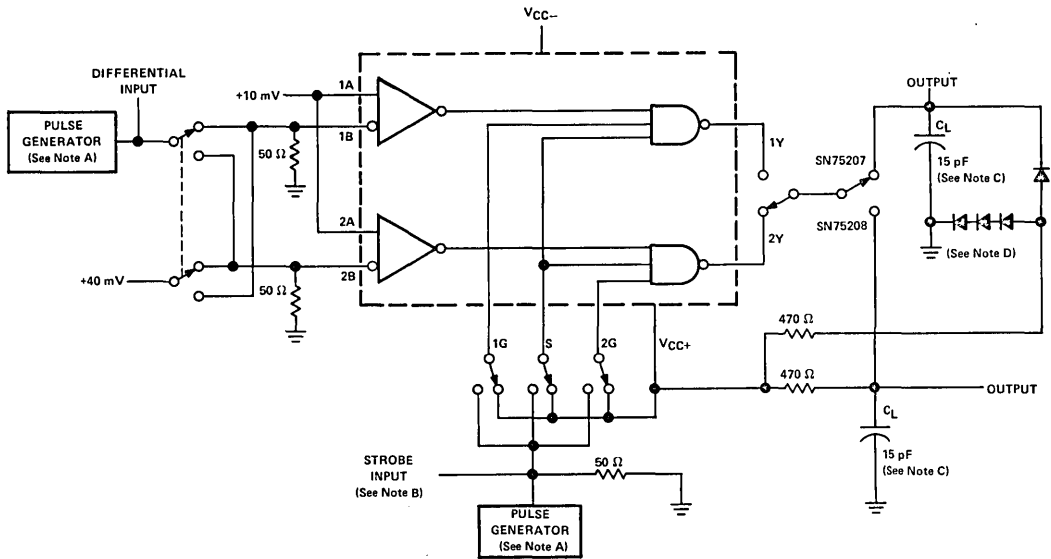

### TEST CIRCUIT

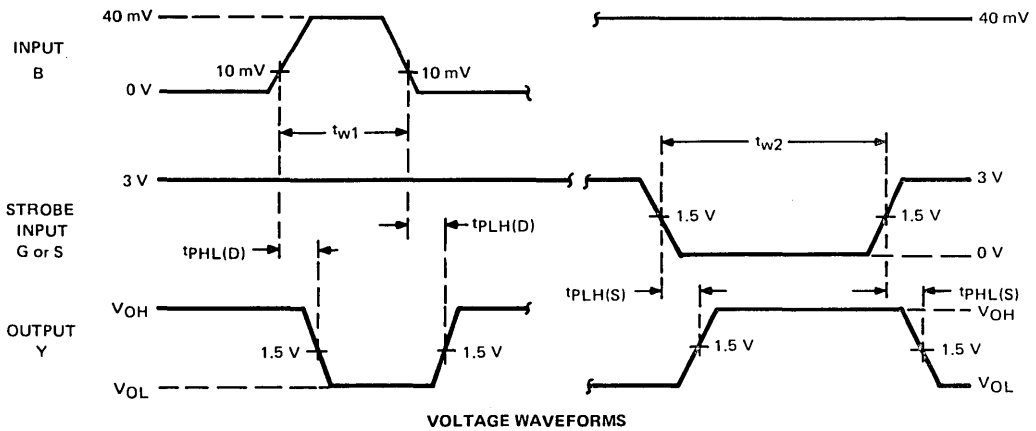

### VOLTAGE WAVEFORMS

- NOTES: A. The pulse generators have the following characteristics:  $Z_{out} = 50 \Omega$ ,  $t_r < 5 \text{ ns}$ ,  $t_f < 5 \text{ ns}$ ,  $t_{w1} = 500 \text{ ns}$  with PRR = 1 MHz,  $t_{w2} = 1 \mu\text{s}$  with PRR = 500 kHz.
- B. Strobe input pulse is applied to Strobe 1G when inputs 1A-1B are being tested, to Strobe S when inputs 1A-1B or 2A-2B are being tested, and to Strobe 2G when inputs 2A-2B are being tested.
- C.  $C_L$  includes probe and jig capacitance.
- D. All diodes are 1N916.

FIGURE 1—PROPAGATION DELAY TIMES

# TYPES SN75207, SN75207B, SN75208, SN75208B DUAL SENSE AMPLIFIERS FOR MOS MEMORIES OR DUAL HIGH-SENSITIVITY LINE RECEIVERS

## TYPICAL APPLICATION DATA

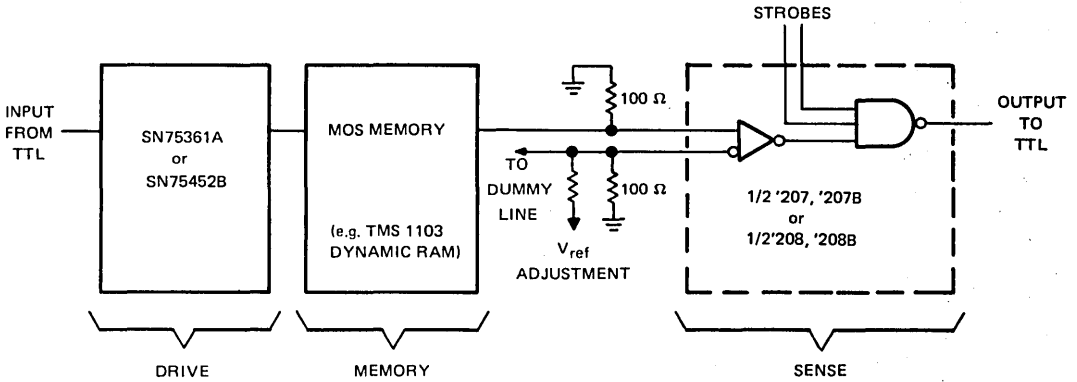
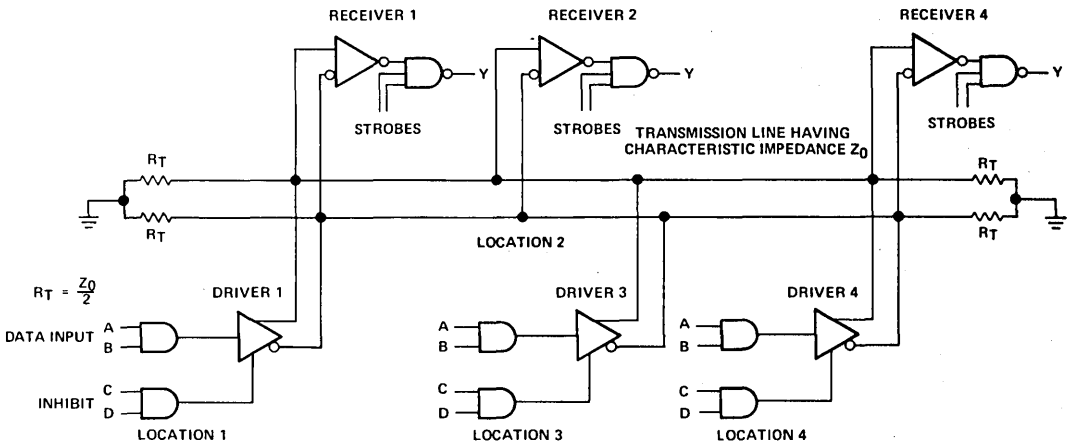

FIGURE 2—MOS MEMORY SENSE AMPLIFIER



Receivers are '207, '207B, '208, or '208B; drivers are SN55109A, SN75109A, SN55110A, SN75110A, or SN75112.

FIGURE 3—DATA-BUS OR PARTY-LINE SYSTEM

**PRECAUTIONS:** When only one receiver in a package is being used, at least one of the differential inputs of the unused receiver should be terminated at some voltage between  $-3$  volts and  $+3$  volts, preferably at ground. Failure to do so will cause improper operation of the unit being used because of common bias circuitry for the current sources of the two receivers. Strobe G of the unused channel should be grounded.



# INTERFACE CIRCUITS

# TYPE SN75270 7-UNIT MOS-TO-TTL CONVERTER AND THERMAL PRINTHEAD DRIVER ARRAY

BULLETIN NO. DL-S 7712061, SEPTEMBER 1973—REVISED APRIL 1977

JORN  
DUAL-IN-LINE PACKAGE (TOP VIEW)

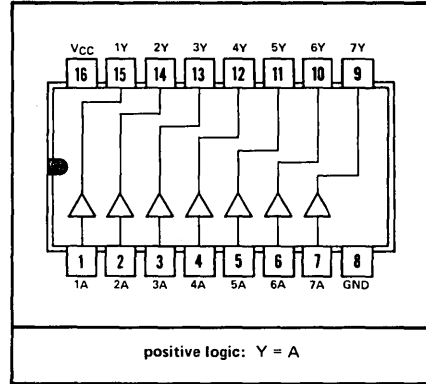

- 7 Single-Ended Noninverting Drivers Per Package
- Inputs Compatible with MOS
- TTL-Compatible Outputs
- Single 5-V Supply

## description

The SN75270 is a monolithic integrated circuit designed for use as a sense amplifier or thermal printhead driver. As a sense amplifier, the device can be used to convert from MOS to TTL levels. As a thermal printhead driver, this device is used with EPN3600-type thermal printheads.

The SN75270 is characterized for operation from 0°C to 70°C.

schematic (each driver)

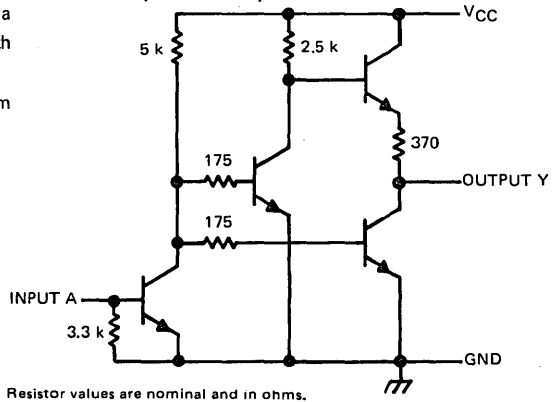

Resistor values are nominal and in ohms.

## absolute maximum ratings over operating free-air temperature range (unless otherwise noted)

Supply voltage, $V_{CC}$ (see Note 1)	7 V
Input current	4 mA
Continuous total dissipation at (or below) 25°C free-air temperature (see Note 2)	800 mW
Operating free-air temperature range	0°C to 70°C
Storage temperature range	-65°C to 150°C
Lead temperature 1/16 inch from case for 60 seconds: J package	300°C
Lead temperature 1/16 inch from case for 10 seconds: N package	260°C

## recommended operating conditions

	MIN	NOM	MAX	UNIT
Supply voltage, $V_{CC}$	4.75	5	5.25	V
High-level input current, $I_{IH}$	0.5		2	mA
Low-level input current, $I_{IL}$	0		0.1	mA
Operating free-air temperature, $T_A$	0		70	°C

NOTES: 1. Voltage values are with respect to network ground terminal.

2. For operation above 25°C free-air temperature, refer to Dissipation Derating Curves in the Thermal Information Section, which starts on page 2-1. In the J package, SN75270 chips are glass-mounted.

# TYPE SN75270 7-UNIT MOS-TO-TTL CONVERTER AND THERMAL PRINTHEAD DRIVER ARRAY

electrical characteristics over recommended operating free-air temperature range

PARAMETER	TEST CONDITIONS	MIN	TYP	MAX	UNIT
$V_{OH}$ High-level output voltage	$V_{CC} = 4.75 \text{ V}$ , $I_{IH} = 500 \mu\text{A}$ , $I_{OH} = -80 \mu\text{A}$	2.4			V
$V_{OL}$ Low-level output voltage	$V_{CC} = 4.75 \text{ V}$ , $I_{IL} = 100 \mu\text{A}$ , $I_{OL} = 3.2 \text{ mA}$			0.4	V
$I_{OH}$ High-level output current	$V_{CC} = 4.75 \text{ V}$ , $I_{IH} = 500 \mu\text{A}$ , $V_O = 1 \text{ V}$	-5			mA
	$V_{CC} = 5.25 \text{ V}$ , $I_{IH} = 500 \mu\text{A}$ , $V_O = 0.25 \text{ V}$			-15	
$I_{CCL}$ Total supply current, all outputs low	$V_{CC} = 5 \text{ V}$ , $I_{IL} = 100 \mu\text{A}$ , $I_O = 0$		20	35	mA

switching characteristics,  $T_A = 25^\circ\text{C}$

PARAMETER	TEST CONDITIONS	MIN	TYP	MAX	UNIT
$t_{pLH}$ Propagation delay time, low-to-high-level output	$V_{CC} = 5 \text{ V}$ , $C_L = 15 \text{ pF}$ ,		30		ns
$t_{pHL}$ Propagation delay time, high-to-low-level output	$R_L = 1.5 \text{ k}\Omega$ , See Figure 1		8		ns

## PARAMETER MEASUREMENT INFORMATION

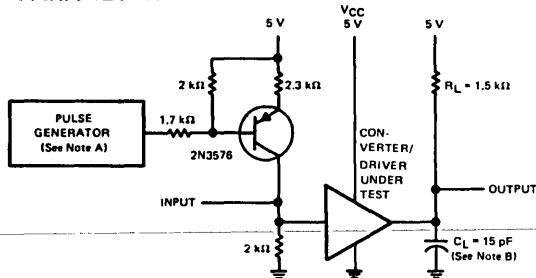

NOTES: A. The pulse generator has the following characteristics:  $Z_{out} = 50 \Omega$ ,  $t_r < 10 \text{ ns}$ ,  $t_f < 10 \text{ ns}$ ,  $PRR = 500 \text{ kHz}$ ,  $t_w = 500 \text{ ns}$ .  
B.  $C_L$  includes probe and jig capacitance.

## TEST CIRCUIT

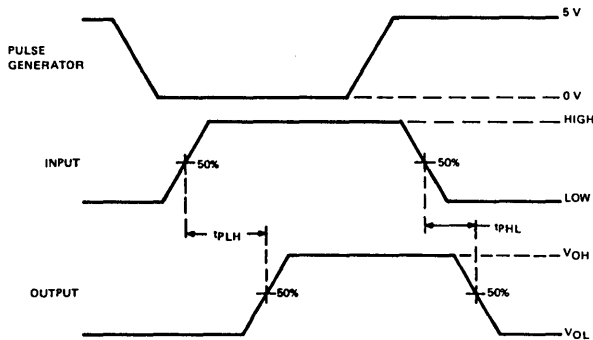

## VOLTAGE WAVEFORMS

FIGURE 1

# TYPE SN75270 7-UNIT MOS-TO-TTL CONVERTER AND THERMAL PRINTHEAD DRIVER ARRAY

## TYPICAL APPLICATION DATA

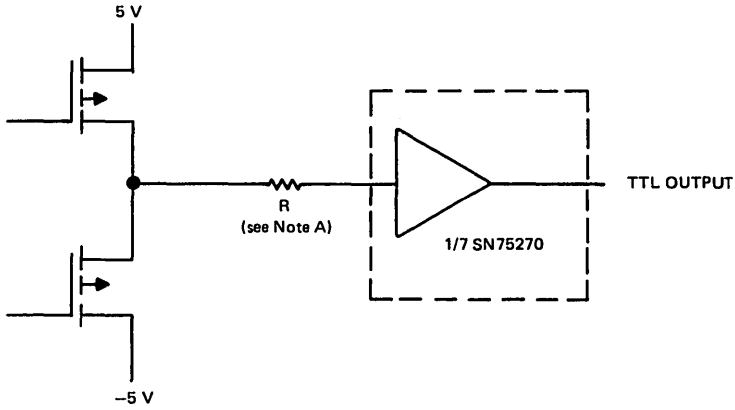

Note A:

$$R = \frac{V_{OH} - V_{BE}}{I_{OH}}$$

$V_{OH}$  = High-level output voltage of MOS device  
 $V_{BE}$  = Base-Emitter voltage of input transistor of SN75270  
 $I_{OH}$  = High-level output current of MOS device

example: let  $V_{OH} = 4\text{ V}$   
 $I_{OH} = 1\text{ mA}$   
 $V_{BE} = 0.7\text{ V}$

$$R = \frac{4 - 0.7}{1} = 3.3\text{ k}\Omega$$

FIGURE 2—MOS TO SN75270 CONNECTION

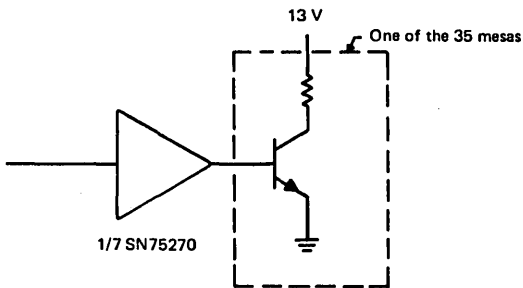

FIGURE 3—THERMAL PRINTHEAD DRIVER FOR  
THE EPN3600 THERMAL PRINTHEAD



# MOS Drivers



MOS DRIVERS

INPUT COMPATIBILITY	POWER SUPPLIES (Nominal)	t <sub>PD</sub> <sup>1</sup> TYPICAL	V <sub>OH</sub> (MIN)	V <sub>OL</sub> (MAX)	DEVICE TYPE	PACKAGE TYPE	DRIVERS PER PACKAGE	ADDITIONAL FEATURES	PAGE NO.
ECL 10K	V <sub>CC1</sub> = 5 V, V <sub>CC2</sub> = 20 V, V <sub>CC3</sub> = 24 V, V <sub>EE</sub> = -5.2 V	33 ns	V <sub>CC2</sub> - 0.3 V	0.3 V	SN75368	J,N	2	<ul style="list-style-type: none"> <li>Compatible with many popular MOS RAMs including the TMS 1103, TMS 1103-1, TMS 4030, and 7001</li> <li>ECL to MOS/TTL driver</li> </ul>	7-67
	V <sub>CC1</sub> = 5 V, V <sub>CC2</sub> = 12 V, V <sub>EE</sub> = -5.2 V, V <sub>BB</sub> = -1.3 V	44 ns	V <sub>CC2</sub> - 0.4 V	0.5 V	SN75320 SN75321	J,N J,N	2	<ul style="list-style-type: none"> <li>Compatible with the TMS 4030 4K RAM and other popular MOS RAMs</li> <li>Fixed ECL input reference voltage (SN75321)</li> <li>External reference voltage (SN75320)</li> <li>Requires two external P-N-P transistors for operation</li> </ul>	7-8
TTL	V <sub>CC1</sub> = 5 V, V <sub>CC2</sub> = 12 V	20 ns	V <sub>CC2</sub> - 1.6 V	0.5 V	SN75367	J,N	4	<ul style="list-style-type: none"> <li>CMOS applications</li> <li>3-state output</li> <li>Separate address and enable/disable inputs for each driver</li> </ul>	7-63
	V <sub>CC1</sub> = 5 V, V <sub>CC2</sub> = 12 V	25 ns	V <sub>CC2</sub> - 1.6 V	1.3 V	SN75357	J,N	4	<ul style="list-style-type: none"> <li>CMOS applications</li> <li>Very low transient current during switching</li> <li>3-state output</li> <li>Separate address and enable/disable inputs for each driver</li> </ul>	7-25
	V <sub>CC1</sub> = 5 V, V <sub>CC2</sub> = 20 V	31 ns	V <sub>CC2</sub> - 0.3 V	0.3 V	SN75375	J,N	4	<ul style="list-style-type: none"> <li>Compatible with many popular MOS RAMs</li> <li>Individual V<sub>CC2</sub> supplies for each driver</li> <li>Two drivers have single inputs; two have dual inputs</li> </ul>	7-99
	V <sub>CC1</sub> = 5 V, V <sub>CC2</sub> = 20 V, V <sub>CC3</sub> = 24 V	31 ns	V <sub>CC2</sub> - 0.3 V	0.3 V	SN75365	J,N	4	<ul style="list-style-type: none"> <li>Compatible with many MOS RAMs including the TMS 1103, TMS 4062, and TMS 4070 16K RAM</li> <li>V<sub>CC2</sub> variable from 5 V to 24 V</li> </ul>	7-48
	V <sub>CC1</sub> = 5 V, V <sub>CC2</sub> = 12 V	31 ns	V <sub>CC2</sub> - 0.4 V	0.5 V	SN75322	J,N	2	<ul style="list-style-type: none"> <li>Compatible with most popular MOS RAMs</li> <li>Separate driver address inputs with common strobe</li> <li>Requires two external P-N-P transistors for operation</li> <li>Low standby power</li> </ul>	7-13

<sup>1</sup>t<sub>PD</sub> = Propagation delay time

MOS DRIVERS (continued)

INPUT COMPATIBILITY	POWER SUPPLIES (Nominal)	t <sub>PD</sub> <sup>†</sup> TYPICAL	V <sub>OH</sub> (MIN)	V <sub>OL</sub> (MAX)	DEVICE TYPE	PACKAGE TYPE	DRIVERS PER PACKAGE	ADDITIONAL FEATURES	PAGE NO.
TTL	V <sub>CC1</sub> = 5 V, V <sub>CC2</sub> = 15 V	31 ns	V <sub>CC2</sub> - 1 V	0.3 V	SN75350	JG,P	2	<ul style="list-style-type: none"> <li>Compatible with many popular MOS RAMs</li> <li>Lower-voltage, high-speed version of the SN75361A</li> <li>V<sub>CC2</sub> variable from 5 V to 18 V</li> </ul>	7-17
	V <sub>CC1</sub> = 5 V, V <sub>CC2</sub> = 15 V, V <sub>CC3</sub> = 18 V	32 ns	V <sub>CC2</sub> - 0.3 V	0.3 V	SN75355	J,N	4	<ul style="list-style-type: none"> <li>Compatible with many popular MOS RAMs</li> <li>Low-voltage version of the SN75365</li> <li>V<sub>CC2</sub> variable from 5 V to 18 V</li> </ul>	7-21
	V <sub>CC1</sub> = 5 V, V <sub>CC2</sub> = 20 V, V <sub>CC3</sub> = 24 V	33 ns	V <sub>CC2</sub> - 0.3 V	0.3 V	SN75366	J,N	4	<ul style="list-style-type: none"> <li>Compatible with many popular MOS RAMs</li> <li>Equivalent to the SN75365 with internal output damping resistor</li> </ul>	7-57
	V <sub>CC1</sub> = 5 V, V <sub>CC2</sub> = 12 V, V <sub>CC3</sub> = 15 V	33 ns	V <sub>CC2</sub> - 0.3 V	0.5 V	SN75363	J,N	2	<ul style="list-style-type: none"> <li>Compatible with many MOS RAMs including the TMS 4030 4K RAM and TMS 4070 16K RAM</li> <li>Separate driver address inputs with common strobe</li> <li>V<sub>CC2</sub> variable from 5 V to 15 V</li> </ul>	7-39
	V <sub>CC1</sub> = 24 V, V <sub>CC2</sub> = 20 V	34 ns	V <sub>CC2</sub> - 0.3 V	0.3 V	SN75364	JG,P	2	<ul style="list-style-type: none"> <li>Compatible with many popular MOS RAMs and shift registers</li> <li>Single-ended inverting drivers</li> </ul>	7-43
	V <sub>CC</sub> = 20 V	35 ns	V <sub>CC</sub> - 1 V	0.3 V	SN75369	JG,P	2	<ul style="list-style-type: none"> <li>Compatible with many popular MOS RAMs and MOS shift registers</li> <li>Single-ended inverting drivers</li> </ul>	7-75
	V <sub>CC1</sub> = 5 V, V <sub>CC2</sub> = 20 V	36 ns	V <sub>CC2</sub> - 1 V	0.3 V	SN75361A	JG,P	2	<ul style="list-style-type: none"> <li>Compatible with many popular MOS RAMs including the TMS 1103, TMS 4062, and TMS 4070 16K RAM</li> <li>V<sub>CC2</sub> variable from 5 V to 24 V</li> </ul>	7-30
	V <sub>SS</sub> = 20 V, V <sub>REF</sub> = 7 V	80 ns			SN75370	J,N	2	Dual read/write amplifier that is designed to interface with I/O terminals of the TMS 4062 and similar type MOS RAMs	7-81
	V <sub>CC1</sub> = 5 V, See features for V <sub>CC2</sub> and V <sub>CC3</sub>	85 ns	V <sub>CC3</sub> - 0.2 V	V <sub>CC2</sub> +2 V	SN55180	J,W	2	<ul style="list-style-type: none"> <li>Compatible with all MOS devices</li> <li>31 V maximum output swing</li> <li>V<sub>CC2</sub> variable from -8 V to -25 V</li> <li>V<sub>CC3</sub> variable from -20 V to 25 V</li> </ul>	7-5

<sup>†</sup>t<sub>PD</sub> = Propagation delay time

7



# INTERFACE CIRCUITS

# TYPE SN55180 DUAL NAND TTL-TO-MOS LEVEL CONVERTER

BULLETIN NO. DL-S 11766, AUGUST 1972 - REVISED APRIL 1981

- Output Compatible with All MOS Devices
- Inputs Fully Compatible with Most TTL and DTL Circuits
- Designed to be Interchangeable with National Semiconductor DS7800 and DS8800
- Standard 5 V Logic Supply Voltage
- Variable VCC2 and VCC3 Supply Voltages
- 31-Volt Maximum Output Swing
- 1 mW Dissipation with Output at High Level

schematic

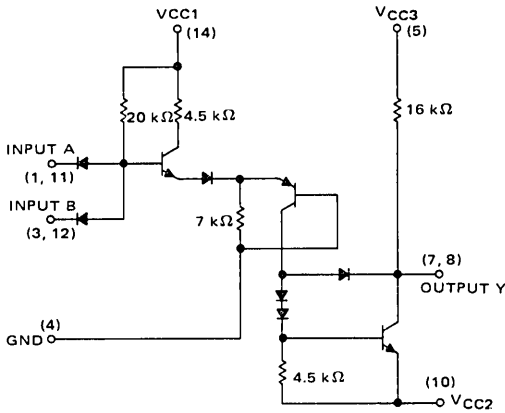

Resistor values shown are nominal.

J OR W PACKAGE  
(TOP VIEW)

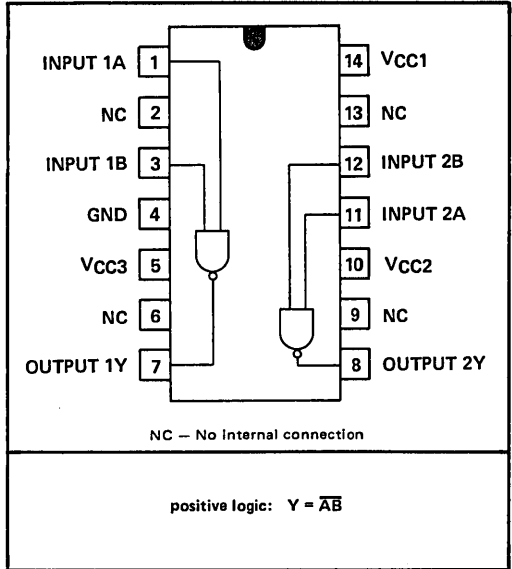

## description

The SN55180 consists of two voltage-level converters designed for interfacing between TTL or DTL voltage levels and those levels associated with high-impedance junction or MOS FET-type devices. This device offers the system designer the flexibility of tailoring the output voltage swing to his application. This can be accomplished by varying the VCC2 and VCC3 supply voltage within the ranges shown in Figure 1. Typical applications include interfacing with MOS shift registers and analog gates.

The SN55180 is characterized for operation over the full military temperature range of  $-55^{\circ}\text{C}$  to  $125^{\circ}\text{C}$ .

## absolute maximum ratings over operating free-air temperature range (unless otherwise noted)

Supply voltage VCC1 (see Note 1)	7 V
Supply voltage VCC2 (see Note 1)	-30 V
Supply voltage VCC3 (see Note 1)	30 V
VCC3 to VCC2 voltage differential	40 V
Input voltage (see Note 1)	5.5 V
Continuous total dissipation at (or below) $112^{\circ}\text{C}$ free-air temperature (see Note 2)	300 mW
Operating free-air temperature range	$-55^{\circ}\text{C}$ to $125^{\circ}\text{C}$
Storage temperature range	$-65^{\circ}\text{C}$ to $150^{\circ}\text{C}$
Lead temperature 1/16 inch from case for 60 seconds	$300^{\circ}\text{C}$

- NOTES: 1. Voltage values are with respect to network ground terminal.  
2. For operation above  $112^{\circ}\text{C}$  free-air temperature, refer to Dissipation Derating Curves in the Thermal Information section, which starts on page 21. In the J package the chips are alloy mounted.

# TYPE SN55180

## DUAL NAND TTL-MOS LEVEL CONVERTER

### recommended operating conditions

	MIN	NOM	MAX	UNIT
Supply voltage, $V_{CC1}$	4.5	5	5.5	V
Supply voltage, $V_{CC2}$ (See Figure 1)	-8		-25	V
Supply voltage, $V_{CC3}$ (See Figure 1)			+25 -20	V
Operating free-air temperature, $T_A$	-55		125	$^{\circ}$ C

Figure 1 shows the boundary conditions within which it is recommended that the SN55180 be operated for proper functioning of these converters. The range of operation for supply  $V_{CC2}$  is shown on the horizontal axis.  $V_{CC2}$  must be between -25 V and -8 V. The allowable range for  $V_{CC3}$  is governed by  $V_{CC2}$ . After a value for  $V_{CC2}$  has been chosen,  $V_{CC3}$  may be selected as any value along a vertical line passing through the  $V_{CC2}$  value and terminated by the boundaries of the recommended operation region. A voltage difference between supplies of at least 5 volts should be maintained for adequate output voltage swing.

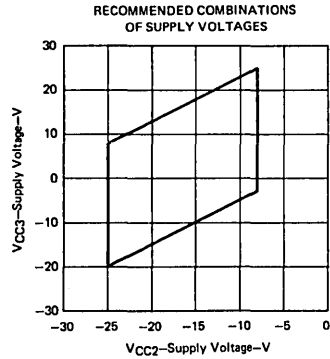

FIGURE 1

### electrical characteristics over recommended operating free-air temperature range (unless otherwise noted) (see note 3)

PARAMETER	TEST CONDITIONS†	MIN	TYP‡	MAX	UNIT
$V_{IH}$ High-level input voltage		2			V
$V_{IL}$ Low-level input voltage				0.8	V
$V_{OH}$ High-level output voltage	$V_{CC1} = \text{MIN}$ , $V_I = 0.8 \text{ V}$ , $I_{OH} = 0$	$V_{CC3} - 0.2$			V
$V_{OL}$ Low-level output voltage	$V_{CC1} = \text{MIN}$ , $V_I = 2 \text{ V}$			$V_{CC2} + 2$	V
$R_{\text{pull-up}}$ Output pull-up resistor (internal)	$T_A = 25^{\circ}\text{C}$	11.5	16	20	$\text{k}\Omega$
$I_{IH}$ High-level input current	$V_{CC1} = \text{MAX}$ , $V_I = 2.4 \text{ V}$		5		$\mu\text{A}$
$I_I$ Input current at maximum input voltage	$V_{CC1} = \text{MAX}$ , $V_I = 5.5 \text{ V}$		1		$\text{mA}$
$I_{IL}$ Low-level input current	$V_{CC1} = \text{MAX}$ , $V_I = 0.4 \text{ V}$		0.2	0.4	$\text{mA}$
$I_{CC1(H)}$ Supply current from $V_{CC1}$ , outputs high (both converters)	$V_{CC1} = \text{MAX}$ , all inputs at 0 V, outputs open		440	820	$\mu\text{A}$
$I_{CC1(L)}$ Supply current from $V_{CC1}$ , outputs low (both converters)	$V_{CC1} = \text{MAX}$ , all inputs at 4.5 V, outputs open		1.7	3.2	$\text{mA}$
$I_{CC3(H)}$ Supply current from $V_{CC3}$ , outputs high (both converters)	$V_{CC3} = \text{MAX}$ , all inputs at 0.8 V, outputs open			20	$\mu\text{A}$

NOTE 3: Minimum and maximum limits apply for all allowable values of  $V_{CC2}$  and  $V_{CC3}$ .

†For conditions shown as MIN or MAX, use appropriate value specified under recommended operating conditions for the applicable device type.

### switching characteristics

PARAMETER	TEST FIGURE	TEST CONDITIONS	MIN	TYP‡	MAX	UNIT
$t_{PLH}$ Propagation delay time, low-to-high-level output	2	$C_L = 15 \text{ pF}$ , See Figure 2		85		ns
$t_{PHL}$ Propagation delay time, high-to-low-level output		$C_L = 15 \text{ pF}$ , See Figure 2		85		ns

‡All typical values are at  $V_{CC1} = 5 \text{ V}$ ,  $V_{CC2} = -22 \text{ V}$ ,  $V_{CC3} = 8 \text{ V}$ ,  $T_A = 25^{\circ}\text{C}$ .

# TYPE SN55180

## DUAL NAND TTL-TO-MOS LEVEL CONVERTER

### PARAMETER MEASUREMENT INFORMATION

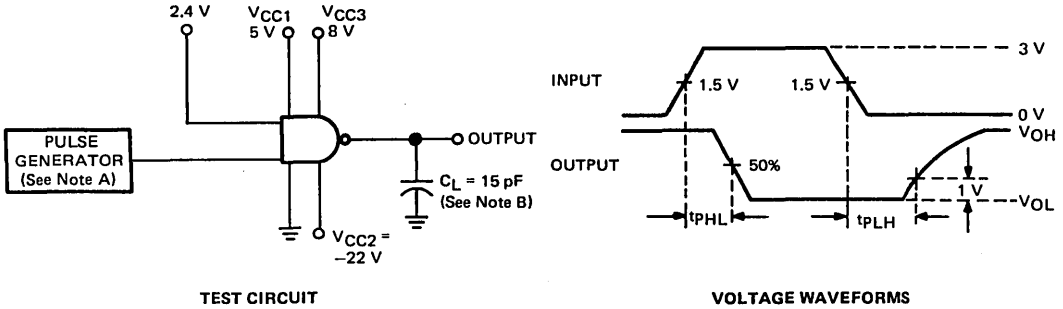

NOTES: A. The pulse generator has the following characteristics:  $Z_{out} = 50 \Omega$ ,  $t_r = 10 \text{ ns}$ ,  $t_f = 10 \text{ ns}$ ,  $PRR = 500 \text{ kHz}$ ,  $t_w = 500 \text{ ns}$ .  
 B.  $C_L$  includes probe and jig capacitance.

FIGURE 2

### TYPICAL CHARACTERISTICS

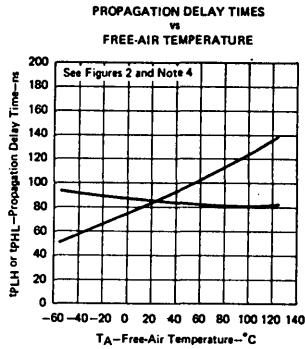

FIGURE 3

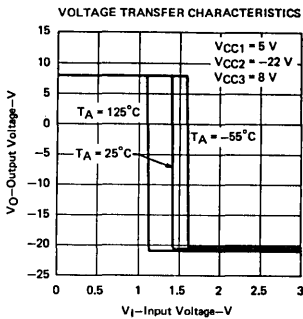

FIGURE 4

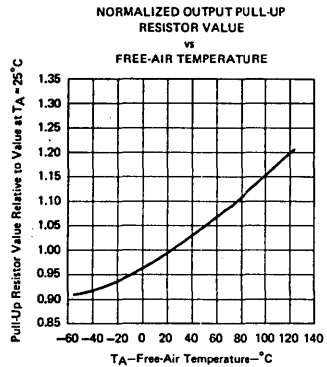

FIGURE 5

# INTERFACE CIRCUITS

# TYPES SN75320, SN75321 DUAL ECL-TO-MOS DRIVERS

BULLETIN NO. DL-S 7712473, APRIL 1977

## MOS MEMORY INTERFACE

- Dual ECL-to-MOS Drivers
- Versatile Interface Circuit for Use Between ECL and High-Current, High-Voltage Systems
- Operates from Standard Bipolar and MOS Supply Voltages
- High-Speed Switching
- Inputs Compatible with Series 10000 ECL and Other Similar ECL Families
- Compatible with Many Popular MOS RAMs
- Negligible 12-V Supply Current and Low 5-V Supply Current when Output is at a Low Level
- Requires 2 External P-N-P Transistors per Package for Operation (Use of TIS149, A5T4260, or A5T4261 Recommended)

J OR N  
DUAL-IN-LINE PACKAGE (TOP VIEW)  
SN75320

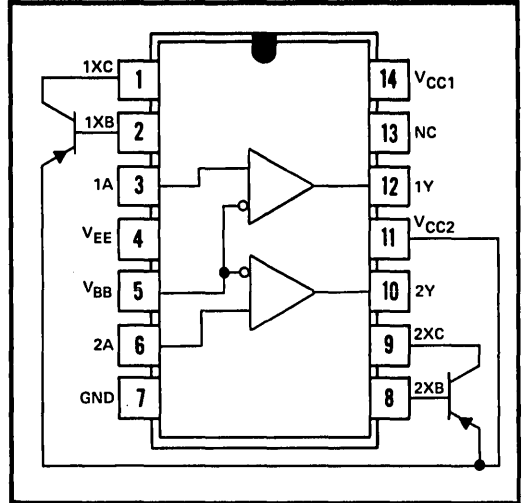

SN75321

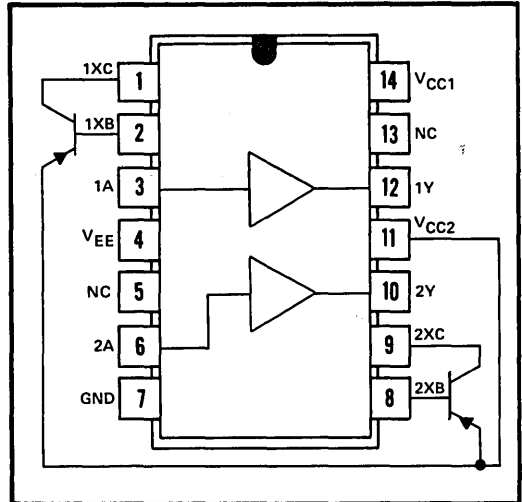

## description

The SN75320 and SN75321 are monolithic dual ECL-to-MOS driver interface circuits. The devices accept standard input signals from Series 10000 ECL and other similar ECL families and provide high-current, high-voltage output levels suitable for driving MOS circuits. Due to the low power dissipation when the driver output is at a low level, these devices are ideal for driving N-channel RAMs such as the 4-k TMS 4030.

The SN75320 and SN75321 operate from a standard TTL  $V_{CC}$  supply ( $V_{CC1}$ ), ECL  $V_{EE}$  supply ( $V_{EE}$ ), and the MOS  $V_{SS}$  supply ( $V_{CC2}$ ). These devices have been optimized for operation with a  $V_{CC2}$  supply voltage from 12 volts to 15 volts, but they are designed to be usable over a much wider range of  $V_{CC2}$ .

Both devices require two external p-n-p transistors per package. Suggested p-n-p transistors are TIS149, A5T4260, and A5T4261. The SN75320 requires an externally generated ECL input reference voltage,  $V_{BB}$ , while the SN75321 features an internally fixed ECL input reference voltage,  $V_{BB}$ , of  $-1.3\text{ V} \pm 10\%$ . The SN75320 can also be used with differential inputs. Both devices are characterized for operation from  $0^\circ\text{C}$  to  $70^\circ\text{C}$ .

Required external p-n-p transistors should be located as close as possible to the SN75320/SN75321.  
NC—No internal connection

FUNCTION TABLE

INPUT A	OUTPUT Y
H	H
L	L

H = high level, L = low level

# TYPES SN75320, SN75321 DUAL ECL-TO-MOS DRIVERS

## schematics of inputs and outputs

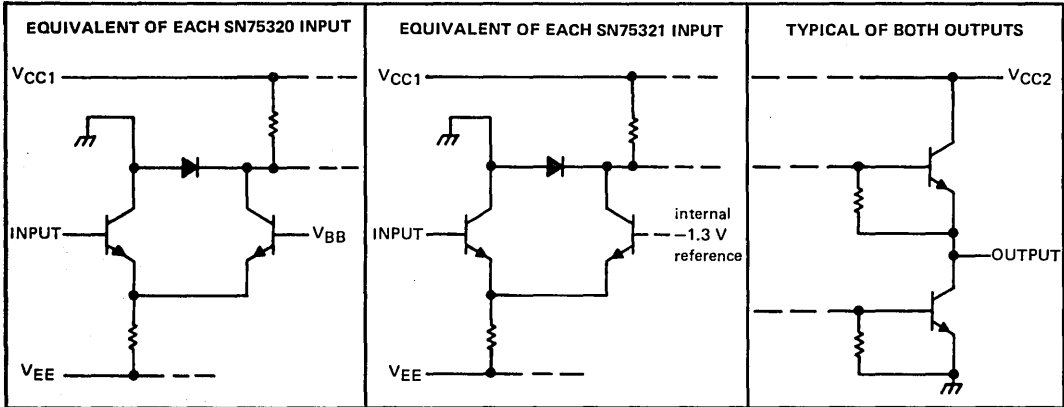

## absolute maximum ratings over operating free-air temperature range (unless otherwise noted)

Supply voltage range of $V_{CC1}$ (see Note 1)	-0.5 V to 7 V
Supply voltage range of $V_{CC2}$	-0.5 V to 15 V
Supply voltage range of $V_{EE}$	-8 V to 0.5 V
Negative voltage of $V_{CC1}$ or $V_{CC2}$ with respect to $V_{EE}$	-0.5 V
Input voltage range	-8 V to 0.5 V
Input voltage with respect to $V_{BB}$ (SN75320)	5.5 V
Negative voltage at any input with respect to $V_{EE}$	-5 V
Continuous total dissipation at (or below) 25°C free-air temperature (see Note 2):	
J package	1025 mW
N package	1150 mW
Operating free-air temperature range	0°C to 70°C
Storage temperature range	-65°C to 150°C
Lead temperature 1/16 inch from case for 60 seconds: J package	300°C
Lead temperature 1/16 inch from case for 10 seconds: N package	260°C

NOTES: 1. Voltage values are with respect to network ground terminal unless otherwise noted.

2. For operation above 25°C free-air temperature, refer to the Dissipation Derating Curves in the Thermal Information section, which starts on page 2-1. In the J package, SN75320 and SN75321 chips are glass-mounted.

## recommended operating conditions

	SN75320			SN75321			UNIT
	MIN	NOM	MAX	MIN	NOM	MAX	
Supply voltage, $V_{CC1}$	4.75	5	5.25	4.75	5	5.25	V
Supply voltage, $V_{CC2}$	4.75	12	15	4.75	12	15	V
Supply voltage, $V_{EE}$	-4.68	-5.2	-5.72	-4.68	-5.2	-5.72	V
Supply voltage, $V_{BB}$	-1.23	-1.3	-1.37				V
Operating free-air temperature, $T_A$	0		70	0		70	°C
Load capacitance, $C_L$	200			200			pF

# TYPES SN75320, SN75321

## DUAL ECL-TO-MOS DRIVERS

definition of input logic levels (see Note 3)

PARAMETER	SN75320		SN75321		UNIT
	B (LEAST POSITIVE)	A (MOST POSITIVE)	B (LEAST POSITIVE)	A (MOST POSITIVE)	
V <sub>IH</sub> High-level input voltage at input A	-1.15	-0.7	-0.9	-0.7	V
V <sub>IL</sub> Low-level input voltage at input A	V <sub>EE</sub>	-1.45	V <sub>EE</sub>	-1.6	V
High-level differential input voltage	150				mV
Low-level differential input voltage		-150			mV

NOTE 3: This data sheet uses the algebraic limit system that has been adopted by the International Electrotechnical Commission for logic voltage levels. The A limit is the more positive (less negative) limit; the B limit is the less positive (more negative) limit.

electrical characteristics over recommended ranges of V<sub>CC1</sub>, V<sub>CC2</sub>, V<sub>EE</sub>, and operating free-air temperature (unless otherwise noted) with V<sub>BB</sub> = -1.3 V for SN75320.

PARAMETER	TEST CONDITIONS	SN75320			SN75321			UNIT	
		MIN	TYP†	MAX	MIN	TYP†	MAX		
V <sub>OH</sub> High-level output voltage	V <sub>IH</sub> = V <sub>IHB</sub>	I <sub>OH</sub> = -10 mA	V <sub>CC2</sub> -1.1	V <sub>CC2</sub> -0.7	V <sub>CC2</sub> -1.1	V <sub>CC2</sub> -0.7	V		
		I <sub>OH</sub> = -400 μA	V <sub>CC2</sub> -0.5	V <sub>CC2</sub> -0.3	V <sub>CC2</sub> -0.5	V <sub>CC2</sub> -0.3			
		I <sub>OH</sub> = -200 μA	V <sub>CC2</sub> -0.4	V <sub>CC2</sub> -0.2	V <sub>CC2</sub> -0.4	V <sub>CC2</sub> -0.2			
V <sub>OL</sub> Low-level output voltage	V <sub>CC2</sub> = 11.4 V, V <sub>IL</sub> = V <sub>IILA</sub> , I <sub>OL</sub> = 10 mA		0.12	0.5		0.12	0.5	V	
I <sub>IH</sub> High-level input current	V <sub>EE</sub> = -5.72 V, V <sub>I</sub> = -0.7 V		80	800		80	800	μA	
I <sub>IL</sub> Low-level input current	V <sub>EE</sub> = -5.72 V, V <sub>I</sub> = -2 V			-10			-10	μA	
	V <sub>EE</sub> = -5.72 V, V <sub>I</sub> = -5.72 V			-100			-100		
I <sub>CC1</sub> (H) Supply current from V <sub>CC1</sub> , both outputs high	V <sub>CC1</sub> = 5.25 V, V <sub>CC2</sub> = 15 V, V <sub>EE</sub> = -5.72 V, No load		18	26		18	26	mA	
I <sub>CC2</sub> (H) Supply current from V <sub>CC2</sub> , both outputs high			9	13		9	13		
I <sub>EE</sub> (H) Supply current from V <sub>EE</sub> , both outputs high			-8	-12		-10	-15		
I <sub>BB</sub> (H) Supply current from V <sub>BB</sub> , both outputs high				-10					μA
I <sub>CC1</sub> (L) Supply current from V <sub>CC1</sub> , both outputs low			18	25		18	25		
I <sub>CC2</sub> (L) Supply current from V <sub>CC2</sub> , both outputs low				0.5			0.5		mA
I <sub>EE</sub> (L) Supply current from V <sub>EE</sub> , both outputs low		-12	-17		-14	-20			
I <sub>BB</sub> (L) Supply current from V <sub>BB</sub> , both outputs low		80	800				μA		

† All typical values are at V<sub>CC1</sub> = 5 V, V<sub>CC2</sub> = 12 V, V<sub>EE</sub> = -5.2 V, V<sub>BB</sub> = -1.3 V (SN75320), and T<sub>A</sub> = 25°C.

switching characteristics, V<sub>CC1</sub> = 5V, V<sub>CC2</sub> = 12 V, V<sub>EE</sub> = -5.2V, T<sub>A</sub> = 25°C

PARAMETER	TEST CONDITIONS	BOTH TYPES			UNIT	
		MIN	TYP	MAX		
t <sub>DLH</sub> Delay time, low-to-high-level output	C <sub>L</sub> = 300 pF, See Figure 1		16	24	ns	
t <sub>DHL</sub> Delay time, high-to-low-level output			30	43		
t <sub>TLH</sub> Transition time, low-to-high-level output			10	20	ns	
t <sub>THL</sub> Transition time, high-to-low-level output			14	20		
t <sub>PLH</sub> Propagation delay time, low-to-high-level output				26	44	ns
t <sub>PHL</sub> Propagation delay time, high-to-low-level output				44	62	

# TYPES SN75320, SN75321 DUAL ECL-TO-MOS DRIVERS

## PARAMETER MEASUREMENT INFORMATION

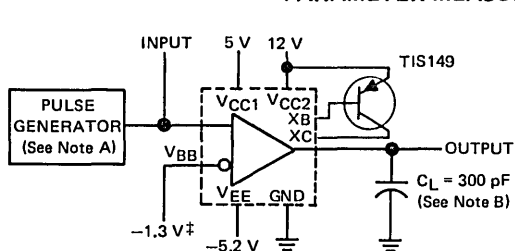

†  $V_{BB}$  is internally generated on SN75321

TEST CIRCUIT

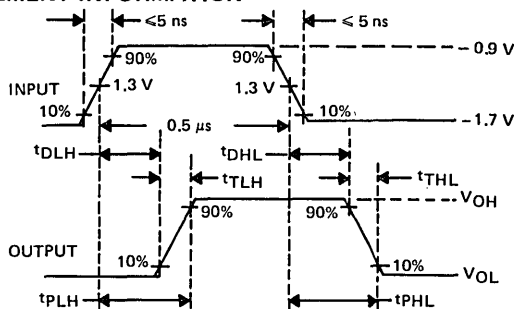

VOLTAGE WAVEFORMS

NOTES: A. The pulse generator has the following characteristics: PRR = 1 MHz,  $Z_{out} \approx 50 \Omega$ .  
B.  $C_L$  includes probe and jig capacitance.

FIGURE 1—SWITCHING TIMES

## TYPICAL CHARACTERISTICS

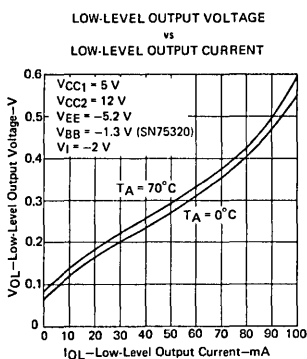

FIGURE 2

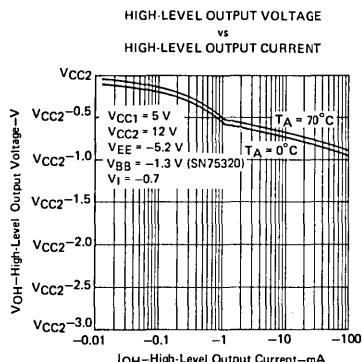

FIGURE 3

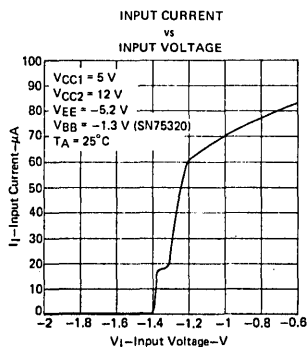

FIGURE 4

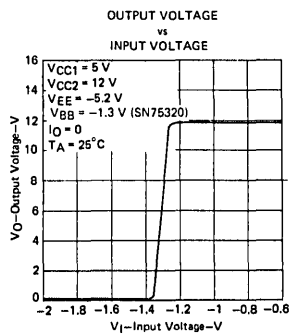
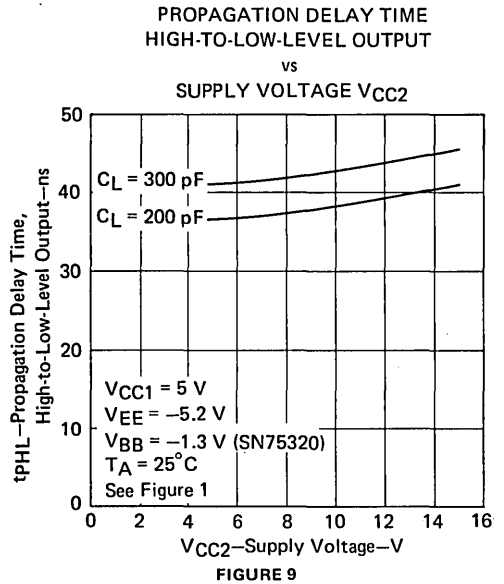
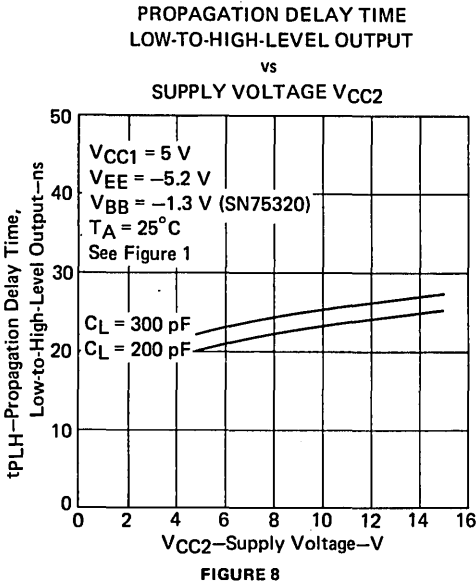
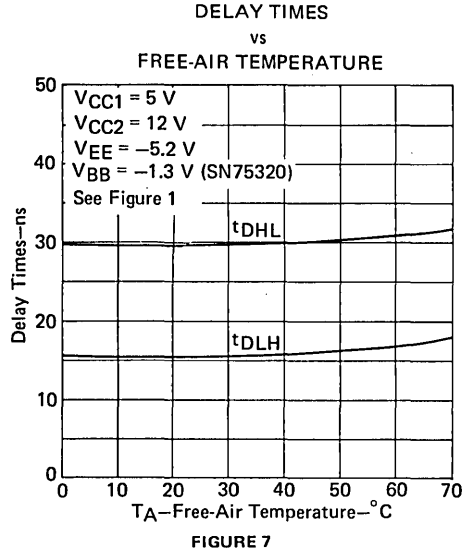
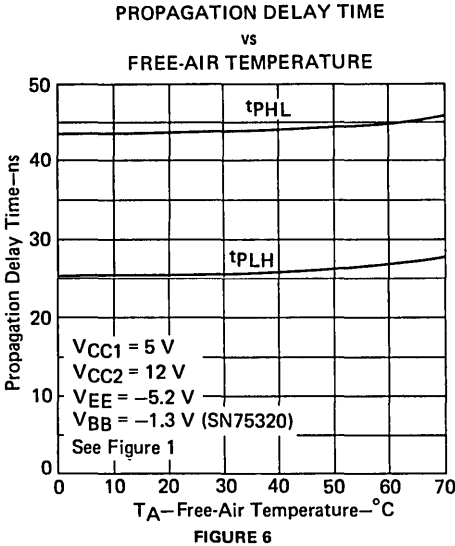

FIGURE 5

# TYPES SN75320, SN75321 DUAL ECL-TO-MOS DRIVERS

## TYPICAL CHARACTERISTICS





# INTERFACE CIRCUITS

# TYPE SN75322 DUAL POSITIVE-AND TTL-TO-MOS DRIVER

BULLETIN NO. DL-S 7712336, MAY 1976—REVISED APRIL 1977

## MOS MEMORY INTERFACE

- Versatile Interface Circuit for Use Between TTL and High-Current, High-Voltage Systems
- Operates from Standard Bipolar and MOS Supply Voltages
- High-Speed Switching
- TTL- and DTL-Compatible Inputs
- Separate Driver Address Inputs with Common Strobe
- $V_{OH}$  and  $V_{OL}$  Compatible with TMS4030 4K RAM and Other Popular MOS RAMs
- Negligible 12-V Supply Current and Low 5-V Supply Current when Output is at a Low Level
- Output in High-Impedance State if 5-V Supply is Lost
- Requires 2 External P-N-P Transistors per Package for Operation (Use of TIS149, A5T4260, or A5T4261 is Recommended)

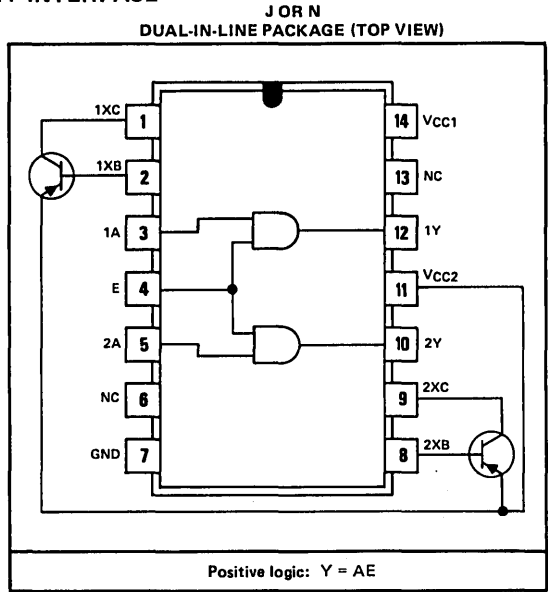

Required external p-n-p transistors should be located as close as possible to the SN75322.

### description

The SN75322 is a monolithic dual TTL-to-MOS driver and interface circuit. The device has separate driver address inputs with common strobe. The device accepts standard TTL and DTL input signals and provides high-current and high-voltage output levels suitable for driving MOS circuits. The SN75322 is designed for driving N-Channel RAMs where low power dissipation is desirable when the driver output is at a low level. Specifically, it may be used to drive the chip-enable input of the TMS4030 MOS RAM.

The SN75322 requires two external P-N-P transistors per package. Suggested P-N-P transistors are TIS149, A5T4260, or A5T4261.

The SN75322 operates from the TTL 5-volt supply and the MOS  $V_{DD}$  supply. With the use of an external pull-down resistor, the driver output of the SN75322 will be forced to the low level if the 5-volt supply is lost. The SN75322 is characterized for operation from 0°C to 70°C.

### schematics of inputs and outputs

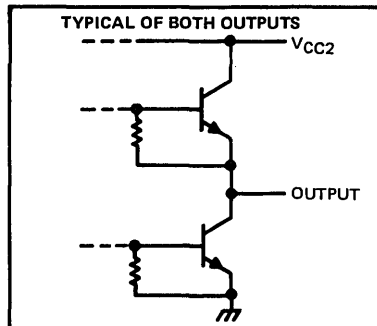
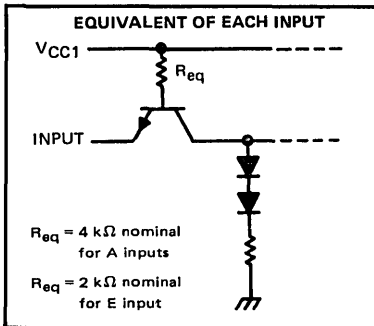

# TYPE SN75322

## DUAL POSITIVE-AND TTL-TO-MOS DRIVER

### absolute maximum ratings over operating free-air temperature range (unless otherwise noted)

Supply voltage range of $V_{CC1}$ (see Note 1)	-0.5 V to 7 V
Supply voltage range of $V_{CC2}$	-0.5 V to 15 V
Input voltage	5.5 V
Continuous total dissipation at (or below) 25°C free-air temperature (see Note 2):	
J package	1025 mW
N package	1150 mW
Operating free-air temperature range	0°C to 70°C
Storage temperature range	-65°C to 150°C
Lead temperature 1/16 inch from case for 60 seconds: J package	300°C
Lead temperature 1/16 inch from case for 10 seconds: N package	260°C

- NOTES: 1. Voltage values are with respect to network ground terminal unless otherwise noted.  
 2. For operation above 25°C free-air temperature, refer to Dissipation Derating Curves in the Thermal Information section, which starts on page 2-1. In the J package, SN75322 chips are glass-mounted.

### recommended operating conditions

	MIN	NOM	MAX	UNIT
Supply voltage, $V_{CC1}$	4.75	5	5.25	V
Supply voltage, $V_{CC2}$	4.75	12	15	V
Operating free-air temperature, $T_A$	0		70	°C
Load capacitance, $C_L$	200			pF

### electrical characteristics over recommended ranges of $V_{CC1}$ , $V_{CC2}$ , and operating free-air temperature (unless otherwise noted)

PARAMETER		TEST CONDITIONS	MIN	TYP <sup>†</sup>	MAX	UNIT
$V_{IH}$	High-level input voltage		2			V
$V_{IL}$	Low-level input voltage				0.8	V
$V_{OH}$	High-level output voltage	$V_{IH} = 2\text{ V}$ , $I_{OH} = -10\text{ mA}$	$V_{CC2}-1.1$		$V_{CC2}-0.9$	V
		$V_{IH} = 2\text{ V}$ , $I_{OH} = -400\text{ }\mu\text{A}$	$V_{CC2}-0.5$		$V_{CC2}-0.25$	
		$V_{IH} = 2\text{ V}$ , $I_{OH} = -200\text{ }\mu\text{A}$	$V_{CC2}-0.4$		$V_{CC2}-0.2$	
$V_{OL}$	Low-level output voltage	$V_{CC2} = 11.4\text{ V}$ , $V_I = 0.8\text{ V}$ , $I_{OL} = 10\text{ mA}$		0.23	0.5	V
$I_I$	Input current at maximum input voltage	$V_I = 5.5\text{ V}$			1	mA
$I_{IH}$	High-level input current	A Inputs E Input	$V_I = 2.4\text{ V}$		40	$\mu\text{A}$
					80	
$I_{IL}$	Low-level input current	A Inputs E Input	$V_I = 0.4\text{ V}$		-1	mA
					-2	
$I_{CC1(L)}$	Supply current from $V_{CC1}$ , both outputs low	$V_{CC1} = 5.25\text{ V}$ , $V_{CC2} = 15\text{ V}$ , All inputs at 0 V, No load		15	20	mA
$I_{CC2(L)}$	Supply current from $V_{CC2}$ , both outputs low	$V_{CC1} = 5.25\text{ V}$ , $V_{CC2} = 15\text{ V}$ , All inputs at 0 V, No load		0.01	0.5	mA
$I_{CC1(H)}$	Supply current from $V_{CC1}$ , both outputs high	$V_{CC1} = 5.25\text{ V}$ , $V_{CC2} = 15\text{ V}$ , All inputs at 5 V, No load		24	34	mA
$I_{CC2(H)}$	Supply current from $V_{CC2}$ both outputs high	$V_{CC1} = 5.25\text{ V}$ , $V_{CC2} = 15\text{ V}$ , All inputs at 5 V, No load		9.5	14	mA

<sup>†</sup>All typical values are at  $V_{CC1} = 5\text{ V}$ ,  $V_{CC2} = 12\text{ V}$ , and  $T_A = 25^\circ\text{C}$ .

# TYPE SN75322 DUAL POSITIVE-AND TTL-TO-MOS DRIVER

switching characteristics,  $V_{CC1} = 5\text{ V}$ ,  $V_{CC2} = 12\text{ V}$ ,  $T_A = 25^\circ\text{C}$

PARAMETER	TEST CONDITIONS	MIN	TYP	MAX	UNIT	
$t_{DLH}$ Delay time, low-to-high-level output	$C_L = 300\text{ pF}$ , See Figure 1		16	21	ns	
$t_{DHL}$ Delay time, high-to-low-level output			18	24	ns	
$t_{TLH}$ Transition time, low-to-high-level output			11	17	ns	
$t_{THL}$ Transition time, high-to-low-level output			13	20	ns	
$t_{PLH}$ Propagation delay time, low-to-high-level output			12	27	38	ns
$t_{PHL}$ Propagation delay time, high-to-low-level output			14	31	44	ns

### PARAMETER MEASUREMENT INFORMATION

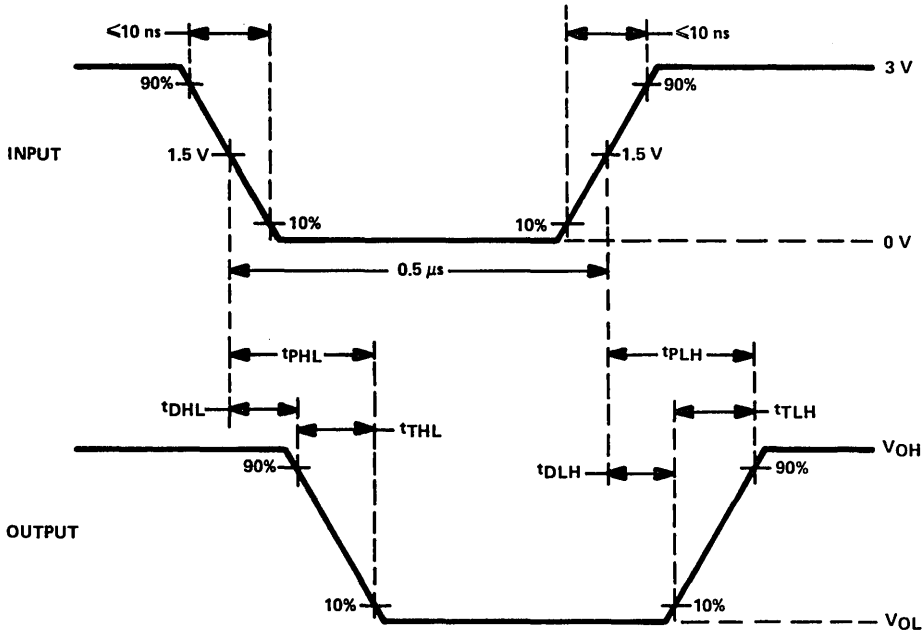
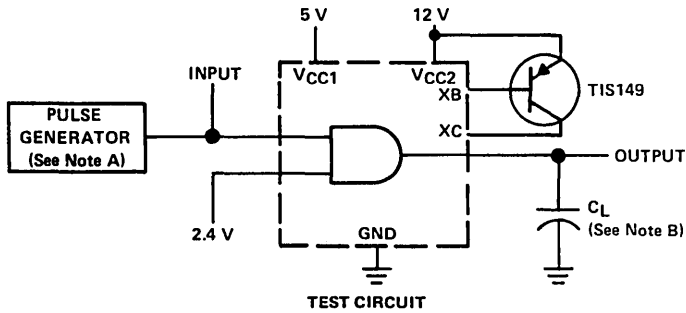

#### VOLTAGE WAVEFORMS

- NOTES: A. The pulse generator has the following characteristics:  $PRR = 1\text{ MHz}$ ,  $Z_{out} \approx 50\ \Omega$ .  
B.  $C_L$  includes probe and jig capacitance.

FIGURE 1—SWITCHING TIMES, EACH DRIVER

# TYPE SN75322

## DUAL POSITIVE-AND TTL-TO-MOS DRIVER

### TYPICAL CHARACTERISTICS

TOTAL DISSIPATION  
(BOTH DRIVERS)

vs

FREQUENCY

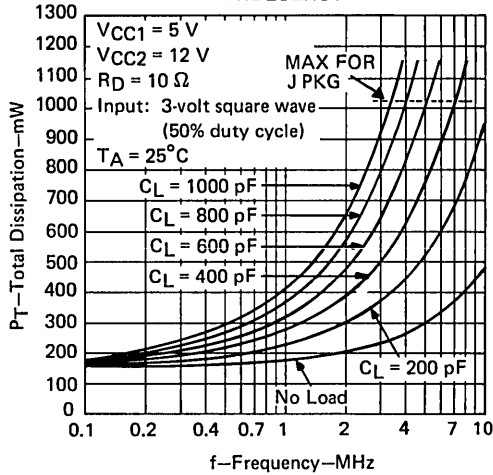
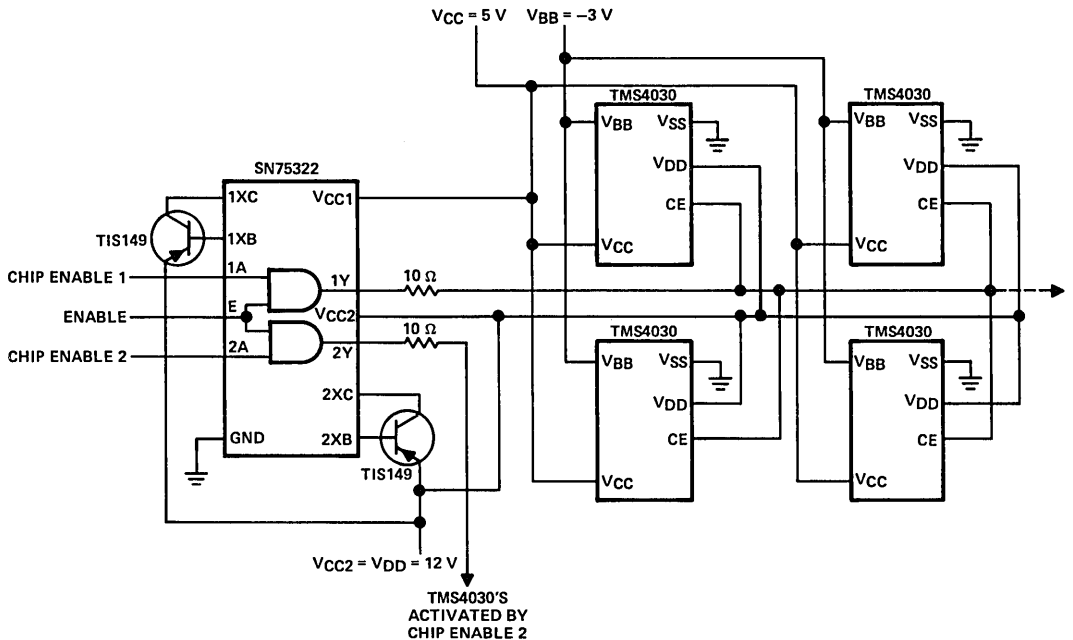

FIGURE 2

### TYPICAL APPLICATION DATA



NOTE: The external P-N-P transistors should be located as close as possible to the SN75322.

FIGURE 3—SN75322 DRIVING TMS4030 MEMORIES

**MOS MEMORY INTERFACE**

- Lower-Voltage, High-Speed Version of SN75361A
- Versatile Interface Circuit for Use Between TTL and High-Current, High-Voltage Systems
- Capable of Driving High-Capacitance Loads
- Compatible With Many Popular MOS RAMs
- VCC2 Supply Voltage Variable over Wide Range . . . 5 V to 18 V
- TTL- and DTL-Compatible Diode-Clamped Inputs
- Operates from Standard Bipolar and MOS Supply Voltages
- Low Standby Power Dissipation
- Special Application . . . 7001 MOS RAM Drivers

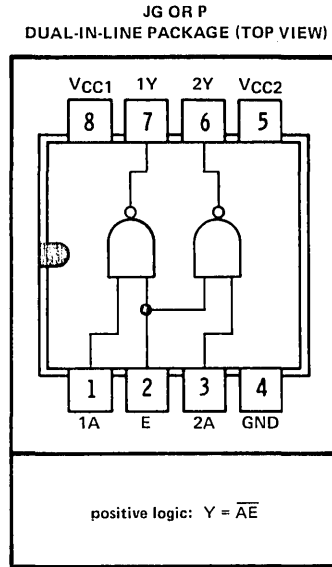

**description**

The SN75350 is a monolithic integrated dual TTL-to-MOS driver and interface circuit. The device accepts standard TTL and DTL input signals and provides high-current and high-voltage output levels suitable for driving MOS circuits. Specifically, it may be used to drive address, control, and timing inputs for several types of MOS RAMs.

The SN75350 operates from the TTL 5-volt supply and the MOS V<sub>SS</sub> supply in many applications. This device has been optimized for operation with VCC2 supply voltage from 12 volts to 18 volts; however, it is designed so as to be useable over a much wider range of VCC2.

The SN75350 has speed advantages over the SN75361A when driving heavy loads with reduced VCC2.

The SN75350 is characterized for operation from 0°C to 70°C.

**schematics of inputs and outputs**

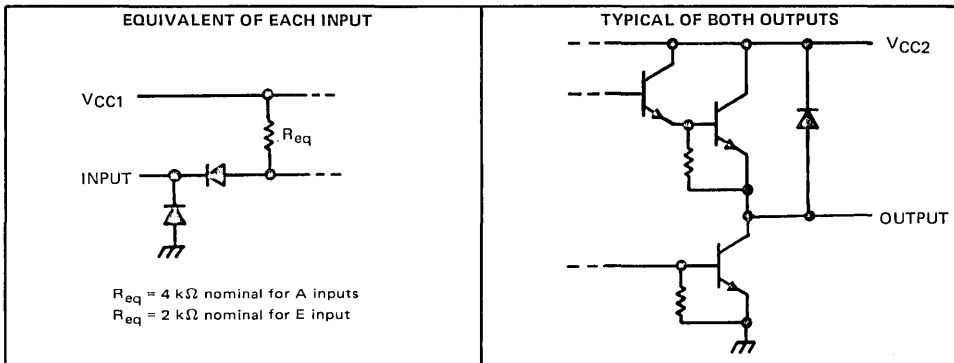



# TYPE SN75350 DUAL NAND TTL-TO-MOS DRIVER

switching characteristics,  $V_{CC1} = 5\text{ V}$ ,  $V_{CC2} = 15\text{ V}$ ,  $T_A = 25^\circ\text{C}$

PARAMETER	TEST CONDITIONS	MIN	TYP	MAX	UNIT
$t_{DLH}$ Delay time, low-to-high-level output	$C_L = 390\text{ pF}$ , $R_D = 10\ \Omega$ , See Figure 1		16	24	ns
$t_{DHL}$ Delay time, high-to-low-level output			15	23	ns
$t_{TLH}$ Transition time, low-to-high-level output			14	22	ns
$t_{THL}$ Transition time, high-to-low-level output			16	24	ns
$t_{PLH}$ Propagation delay time, low-to-high-level output			30	46	ns
$t_{PHL}$ Propagation delay time, high-to-low-level output			31	47	ns

## PARAMETER MEASUREMENT INFORMATION

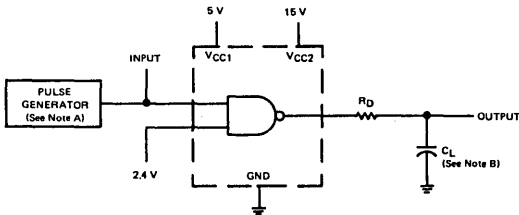

TEST CIRCUIT

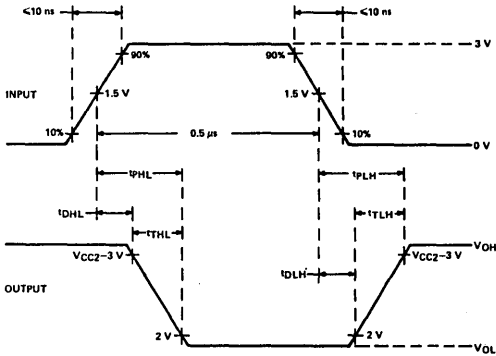

VOLTAGE WAVEFORMS

- NOTES: A. The pulse generator has the following characteristics:  
 PRR = 1 MHz,  $Z_{out} \approx 50\ \Omega$ .  
 B.  $C_L$  includes probe and jig capacitance.

FIGURE 1—SWITCHING TIMES, EACH DRIVER

## TYPICAL CHARACTERISTICS

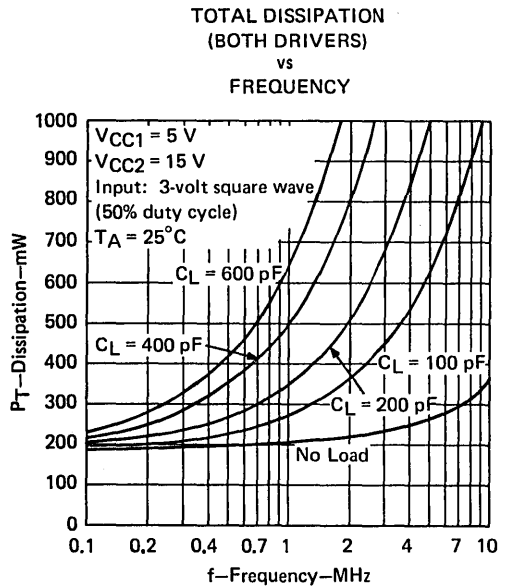

FIGURE 2





**MOS MEMORY INTERFACE**

- Quad Positive-Logic NAND TTL-to-MOS Driver
- Versatile Interface Circuit for Use between TTL and High-Current, High-Voltage Systems
- Capable of Driving High-Capacitance Loads
- Compatible with Many Popular MOS RAMs
- VCC2 Supply Voltage Variable over Wide Range to 18 Volts Maximum
- VCC3 Supply Voltage Pin Available
- VCC3 Pin Can Be Connected to VCC2 Pin in Some Applications
- TTL- and DTL-Compatible Diode-Clamped Inputs
- Operates from Standard Bipolar and MOS Supply Voltages
- Two Common Enable Inputs per Gate-Pair
- High-Speed Switching
- Low Standby Power Dissipation
- High-Speed SN75365-Type Device with Lower VCC2 Voltage Requirement

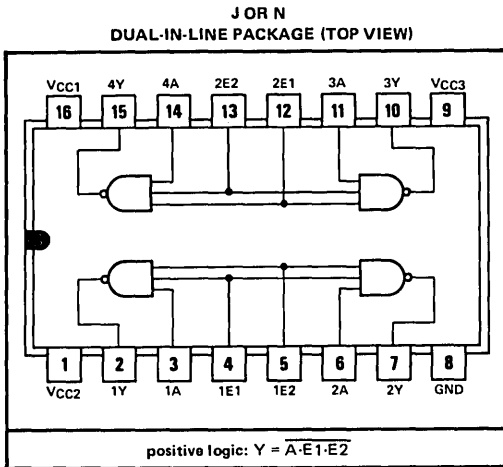

**description**

The SN75355 is a monolithic quadruple TTL-to-MOS driver and interface circuit. The device accepts standard TTL and DTL input signals and provides high-current and high-voltage output levels suitable for driving MOS circuits. Specifically, it may be used to drive address, control, and timing inputs for several types of MOS RAMs or microprocessor multiphase clock inputs.

The SN75355 operates from the TTL 5-volt supply and the MOS V<sub>SS</sub> and V<sub>BB</sub> supplies in many applications. This device has been optimized for operation with V<sub>CC2</sub> supply voltage from 12 volts to 18 volts, and with nominal V<sub>CC3</sub> supply voltage from 3 volts to 4 volts higher than V<sub>CC2</sub>. In some applications the V<sub>CC3</sub> power supply can be eliminated by connecting the V<sub>CC3</sub> pin to the V<sub>CC2</sub> pin.

The SN75355 has speed advantages over the SN75365 when driving highly capacitive loads with V<sub>CC2</sub> reduced to within the range of 12 to 15 volts.

The SN75355 is characterized for operation from 0°C to 70°C.

**schematic (each driver)**

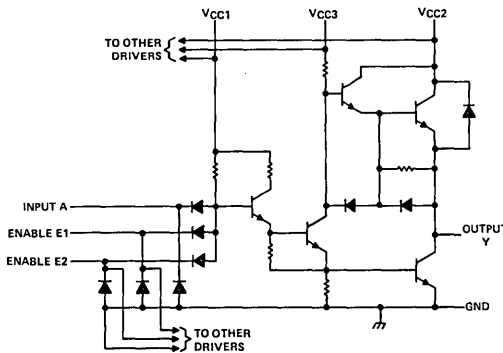

**7**

# TYPE SN75355

## QUADRUPLE NAND TTL-TO-MOS DRIVER

### absolute maximum ratings over operating free-air temperature range (unless otherwise noted)

Supply voltage range of $V_{CC1}$ (see Note 1)	-0.5 V to 7 V
Supply voltage range of $V_{CC2}$	-0.5 V to 19 V
Supply voltage range of $V_{CC3}$	-0.5 V to 19 V
Input voltage	5.5 V
Inter-input voltage (see Note 2)	5.5 V
Continuous total dissipation at (or below) 25°C free-air temperature (see Note 3): J package	1025 mW
N package	1150 mW
Operating free-air temperature range	0°C to 70°C
Storage temperature range	-65°C to 150°C
Lead temperature 1/16 inch from case for 60 seconds: J package	300°C
Lead temperature 1/16 inch from case for 10 seconds: N package	260°C

- NOTES: 1. Voltage values are with respect to network ground terminal unless otherwise noted.  
 2. This rating applies between any two inputs of any one of the gates.  
 3. For operation above 25°C free-air temperature, refer to Dissipation Derating Curves in the Thermal Information section, which starts on page 2-1. In the J package, SN75355 chips are glass-mounted.

### recommended operating conditions

	MIN	NOM	MAX	UNIT
Supply voltage, $V_{CC1}$	4.75	5	5.25	V
Supply voltage, $V_{CC2}$	4.75	15	18	V
Supply voltage, $V_{CC3}$	$V_{CC2}$	18	18	V
Voltage difference between supply voltages: $V_{CC3}-V_{CC2}$	0	3	4	V
Operating free-air temperature, $T_A$	0		70	°C

# TYPE SN75355

## QUADRUPLE NAND TTL-TO-MOS DRIVE

electrical characteristics over recommended ranges of  $V_{CC1}$ ,  $V_{CC2}$ ,  $V_{CC3}$  and operating free-air temperature (unless otherwise noted)

PARAMETER	TEST CONDITIONS		MIN	TYP†	MAX	UNIT
$V_{IH}$ High-level input voltage			2			V
$V_{IL}$ Low-level input voltage					0.8	V
$V_{IK}$ Input clamp voltage	$I_I = -12$ mA				-1.5	V
$V_{OH}$ High-level output voltage	$V_{CC3} = V_{CC2} + 3$ V, $V_{IL} = 0.8$ V, $I_{OH} = -100$ $\mu$ A		$V_{CC2} - 0.3$	$V_{CC2} - 0.1$		V
	$V_{CC3} = V_{CC2} + 3$ V, $V_{IL} = 0.8$ V, $I_{OH} = -10$ mA		$V_{CC2} - 1.2$	$V_{CC2} - 0.9$		
	$V_{CC3} = V_{CC2}$ , $V_{IL} = 0.8$ V, $I_{OH} = -50$ $\mu$ A		$V_{CC2} - 1$	$V_{CC2} - 0.7$		
	$V_{CC3} = V_{CC2}$ , $V_{IL} = 0.8$ V, $I_{OH} = -10$ mA		$V_{CC2} - 2.3$	$V_{CC2} - 1.8$		
$V_{OL}$ Low-level output voltage	$V_{IH} = 2$ V, $I_{OL} = 10$ mA			0.15	0.3	V
	$V_{CC3} = 12$ to 18 V, $V_{IH} = 2$ V, $I_{OL} = 40$ mA			0.25	0.5	
$V_{OK}$ Output clamp voltage	$V_I = 0$ V, $I_{OH} = 20$ mA				$V_{CC2} + 1.5$	V
$I_I$ Input current at maximum input voltage	$V_I = 5.5$ V				1	mA
$I_{IH}$ High-level input current	$V_I = 2.4$ V	A inputs			40	$\mu$ A
		E1 and E2 inputs			80	
$I_{IL}$ Low-level input current	$V_I = 0.4$ V	A inputs		-1	-1.6	mA
		E1 and E2 inputs		-2	-3.2	
$I_{CC1(H)}$ Supply current from $V_{CC1}$ , all outputs high	$V_{CC1} = 5.25$ V, $V_{CC3} = 18$ V, No load	$V_{CC2} = 15$ V, All inputs at 0 V,		4.5	6.5	mA
$I_{CC2(H)}$ Supply current from $V_{CC2}$ , all outputs high				-3	-4.5	
$I_{CC3(H)}$ Supply current from $V_{CC3}$ , all outputs high				3	5	
$I_{CC1(L)}$ Supply current from $V_{CC1}$ , all outputs low	$V_{CC1} = 5.25$ V, $V_{CC3} = 18$ V, No load	$V_{CC2} = 18$ V, All inputs at 5 V,		33	47	mA
			$I_{CC2(L)}$ Supply current from $V_{CC2}$ , all outputs low		2	
			$I_{CC3(L)}$ Supply current from $V_{CC3}$ , all outputs low		19	
$I_{CC2(H)}$ Supply current from $V_{CC2}$ , all outputs high	$V_{CC1} = 5.25$ V, $V_{CC3} = 18$ V, No load	$V_{CC2} = 18$ V, All inputs at 0 V,			0.25	mA
			$I_{CC3(H)}$ Supply current from $V_{CC3}$ , all outputs high			
$I_{CC2(S)}$ Supply current from $V_{CC2}$ , standby condition	$V_{CC1} = 0$ V, $V_{CC3} = 18$ V, No load	$V_{CC2} = 18$ V, All inputs at 5 V,			0.25	mA
			$I_{CC3(S)}$ Supply current from $V_{CC3}$ , standby condition			

† All typical values are at  $V_{CC1} = 5$  V,  $V_{CC2} = 15$  V,  $V_{CC3} = 18$  V, and  $T_A = 25^\circ$  C, except for  $V_{OH}$  for which  $V_{CC2}$  and  $V_{CC3}$  are as stated under test conditions.

switching characteristics,  $V_{CC1} = 5$  V,  $V_{CC2} = 12$  V,  $V_{CC3} = 15$  V,  $T_A = 25^\circ$  C

PARAMETER	TEST CONDITIONS	MIN	TYP	MAX	UNIT
$t_{DLH}$ Delay time, low-to-high-level output	$C_L = 200$ pF, $R_D = 24$ $\Omega$ , See Figure 1		18	28	ns
$t_{DHL}$ Delay time, high-to-low-level output			11	17	ns
$t_{TLH}$ Transition time, low-to-high-level output			14	21	ns
$t_{THL}$ Transition time, high-to-low-level output			13	20	ns
$t_{PLH}$ Propagation delay time, low-to-high-level output			32	49	ns
$t_{PHL}$ Propagation delay time, high-to-low-level output			24	37	ns

# TYPE SN75355 QUADRUPLE NAND TTL-TO-MOS DRIVER

## PARAMETER MEASUREMENT INFORMATION

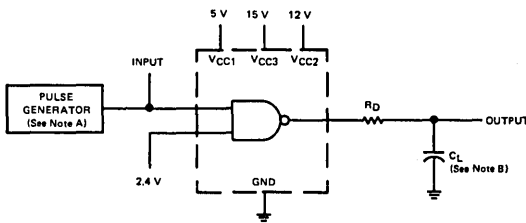

TEST CIRCUIT

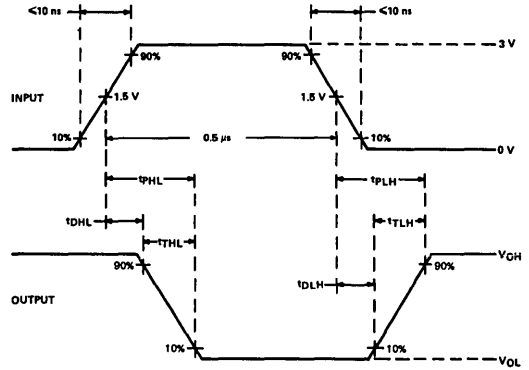

VOLTAGE WAVEFORMS

- NOTES: A. The pulse generator has the following characteristics: PRR = 1 MHz,  $Z_{out} \approx 50 \Omega$ .  
B.  $C_L$  includes probe and jig capacitance.

FIGURE 1—SWITCHING TIMES, EACH DRIVER

## TYPICAL CHARACTERISTICS

TOTAL DISSIPATION  
(ALL FOUR DRIVERS)  
VS  
FREQUENCY

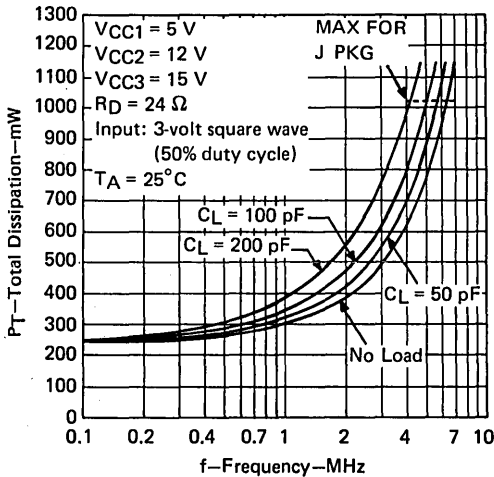

FIGURE 2

TOTAL DISSIPATION  
(ALL FOUR DRIVERS)  
VS  
FREQUENCY

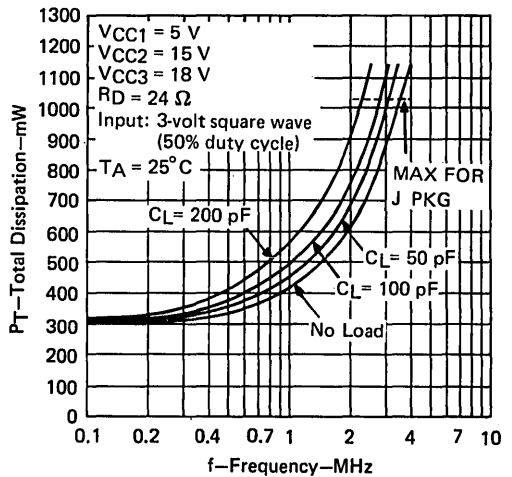

FIGURE 3

# INTERFACE CIRCUITS

# TYPE SN75357 QUADRUPLE TTL-TO-MOS DRIVER WITH 3-STATE OUTPUTS

BULLETIN NO. DL-S 7712563, JULY 1977

## MOS MEMORY INTERFACE

- Quadruple Inverting TTL-to-MOS Drivers
- 3-State Outputs
- CMOS Applications
- High-Speed Switching
- Very Low Transient Current During Switching
- Separate Address and Enable/Disable Inputs for Each Driver
- VCC2 Variable Over Wide Range . . . 5 V to 13.2 V

### description

The SN75357 is a monolithic quadruple TTL-to-MOS driver and interface circuit with three-state outputs. The device accepts standard TTL and DTL input signals and creates output levels suitable for driving MOS devices.

Each driver output may be disabled to the high-impedance state by taking the C input high to allow multiple drivers to be connected to the same bus line for selective enable operation. The SN75357 is designed such that the output disable times are shorter than the output enable times to minimize the possibility that two outputs will attempt to take a common bus line to opposite logic levels.

The device has very low transient supply current during switching. It also features a minimum high-level output voltage of VCC2 -1.6 volts, and a maximum low-level output voltage of 1.3 volts.

The SN75357 is characterized for operation from 0°C to 70°C.

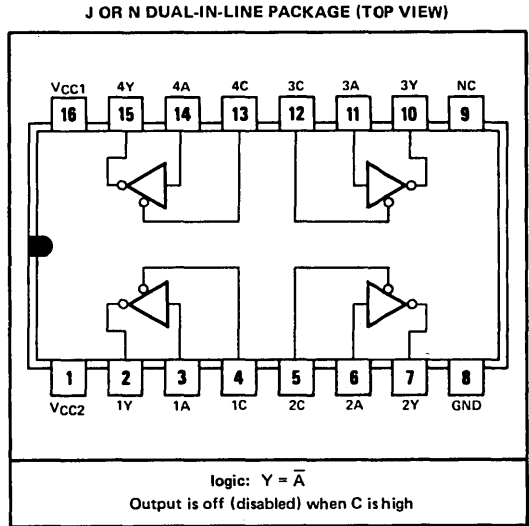

NC—No internal connection

### schematics of inputs and outputs

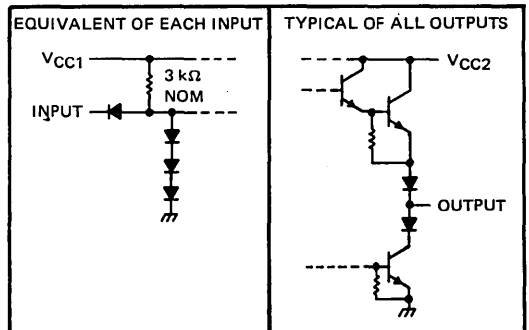

7

### absolute maximum ratings over operating free-air temperature range (unless otherwise noted)

Supply voltage range of VCC1 (see Note 1)	-.0.5 V to 7 V
Supply voltage range of VCC2	-.0.5 V to 15 V
Input voltage	5.5 V
Continuous total dissipation at (or below) 25°C free-air temperature (see Note 2): J package	1025 mW
N package	1150 mW
Operating free-air temperature range	0°C to 70°C
Storage temperature range	-65°C to 150°C
Lead temperature 1/16 inch from case for 60 seconds: J package	300°C
Lead temperature 1/16 inch from case for 10 seconds: N package	260°C

NOTES: 1. Voltage values are with respect to network ground terminal unless otherwise noted.

2. For operation above 25°C free-air temperature, refer to Dissipation Derating Curves in the Thermal Information Section, which starts on page 2-1. In the J package, SN75257 chips are glass-mounted.

# TYPE SN75357

## QUADRUPLE TTL-TO-MOS DRIVER WITH 3-STATE OUTPUTS

### recommended operating conditions

	MIN	NOM	MAX	UNIT
Supply voltage, $V_{CC1}$	4.75	5	5.25	V
Supply voltage, $V_{CC2}$	4.75	12	13.2	V
Operating free-air temperature, $T_A$	0		70	°C

### electrical characteristics over recommended ranges of $V_{CC1}$ , $V_{CC2}$ , and operating free-air temperature (unless otherwise noted)

PARAMETER		TEST CONDITIONS	MIN	TYP†	MAX	UNIT
$V_{IH}$	High-level input voltage		2			V
$V_{IL}$	Low-level input voltage				0.8	V
$V_{OH}$	High-level output voltage	$V_{CC1} = 4.75$ V, $V_{CC2} = 10.8$ V, A inputs at 0.8 V, C inputs at 0.8 V, $I_O = -50$ $\mu$ A	$V_{CC2} - 1.6$	$V_{CC2} - 1.2$		V
$V_{OL}$	Low-level output voltage	$V_{CC1} = 4.75$ V, $V_{CC2} = 10.8$ V, C inputs = 0.8 V, $I_O = 10$ mA A inputs at 2 V,		1.0	1.3	V
$I_I$	Input current at maximum input voltage	$V_I = 5.5$ V			1	mA
$I_{IH}$	High-level input current	$V_I = 2.4$ V			40	$\mu$ A
$I_{IL}$	Low-level input current	A inputs		-1.5	-2.2	mA
		C inputs	$V_I = 0.4$ V		-1.6	
$I_{OZH}$	Off-state output current, high-level voltage applied	$V_{CC1} = 5$ V, $V_{CC2} = 12$ V, A inputs at 0 V, C inputs at 2.4 V, $V_O = 12$ V			-250	$\mu$ A
$I_{OZL}$	Off-state output current, low-level voltage applied	$V_{CC1} = 5$ V, $V_{CC2} = 12$ V, A inputs at 2.4 V, C inputs at 2.4 V, $V_O = 0$ V			250	$\mu$ A
$I_{CC1(H)}$	Supply current from $V_{CC1}$ , all outputs high	$V_{CC1} = 5.25$ V, $V_{CC2} = 13.2$ V, All inputs at 0 V, No load		11	16	mA
$I_{CC2(H)}$	Supply current from $V_{CC2}$ , all outputs high				0.6	mA
$I_{CC1(L)}$	Supply current from $V_{CC1}$ , all outputs low	$V_{CC1} = 5.25$ V, $V_{CC2} = 13.2$ V, A inputs at 5 V, C inputs at 0 V, No load		17	22	mA
$I_{CC2(L)}$	Supply current from $V_{CC2}$ , all outputs low			21	30	mA
$I_{CC1(Z)}$	Supply current from $V_{CC1}$ , all outputs off	$V_{CC1} = 5.25$ V, $V_{CC2} = 13.2$ V, A inputs at 5 V, C inputs at 5 V, No load		27	36	mA
$I_{CC1(Z)}$	Supply current from $V_{CC1}$ , all outputs off	$V_{CC1} = 5.25$ V, $V_{CC2} = 13.2$ V, A input at 0 V, C inputs at 5 V, No load		27	36	mA
$I_{CC2(Z)}$	Supply current from $V_{CC2}$ , all outputs off	$V_{CC1} = 5.25$ V, $V_{CC2} = 13.2$ V, A inputs at 5 V, C inputs at 5 V, No load		26	34	mA

† All typical values are at  $V_{CC1} = 5$  V,  $V_{CC2} = 12$  V, and  $T_A = 25^\circ$ C except for  $V_{OH}$  for which  $V_{CC1}$  and  $V_{CC2}$  are as stated under test conditions.

# TYPE SN75357 QUADRUPLE TTL-TO-MOS DRIVER WITH 3-STATE OUTPUTS

switching characteristics,  $V_{CC1} = 5\text{ V}$ ,  $V_{CC2} = 12\text{ V}$ ,  $T_A = 25^\circ\text{C}$

PARAMETER	TEST CONDITIONS	MIN	TYP	MAX	UNIT
$t_{PLH}$	Propagation delay time, low-to-high-level output	10	21	32	ns
$t_{PHL}$	Propagation delay time, high-to-low-level output	10	20	32	ns
$t_{TLH}$	Transition time, low-to-high level output	5	14	25	ns
$t_{THL}$	Transition time, high-to-low level output	10	20	32	ns
$t_{PZH}$	Output enable time to high level	10	22	32	ns
$t_{PZL}$	Output enable time to low level	12	26	36	ns
$t_{PHZ}$	Output disable time from high level	1	6	12	ns
$t_{PLZ}$	Output disable time from low level	10	18	30	ns
$I_{CC2m(LH)}$	Peak transient supply current, low-to-high level output	20			mA
$I_{CC2m(HL)}$	Peak transient supply current, high-to-low level output	15			mA

## PARAMETER MEASUREMENT INFORMATION

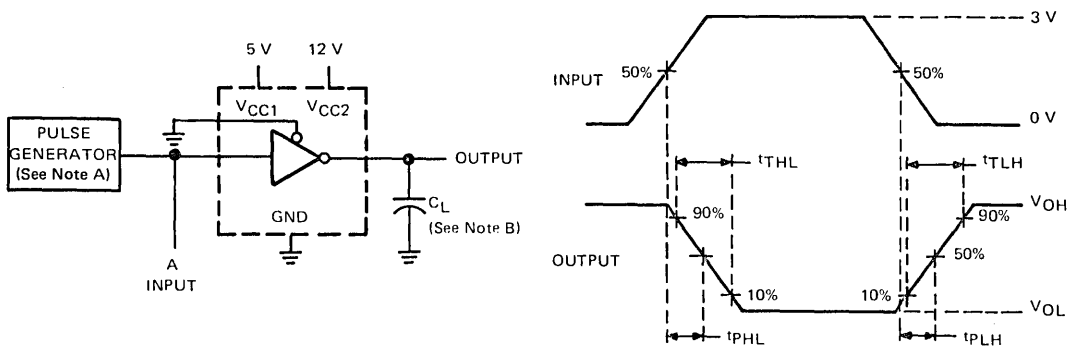

FIGURE 1—TEST CIRCUIT AND VOLTAGE WAVEFORMS FOR  $t_{PLH}$ ,  $t_{PHL}$ ,  $t_{TLH}$ ,  $t_{THL}$

NOTES: A. The pulse generator has the following characteristics: PRR = 1 MHz,  $Z_{out} = 50\ \Omega$ .  
 B.  $C_L$  includes probe and jig capacitance.

# TYPE SN75357

## QUADRUPLE TTL-TO-MOS DRIVER WITH 3-STATE OUTPUTS

### PARAMETER MEASUREMENT INFORMATION

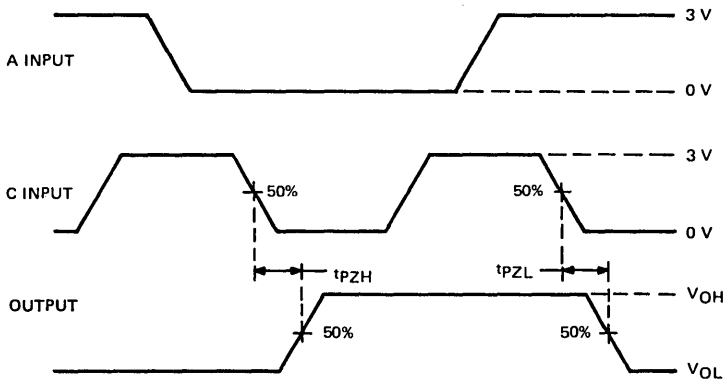
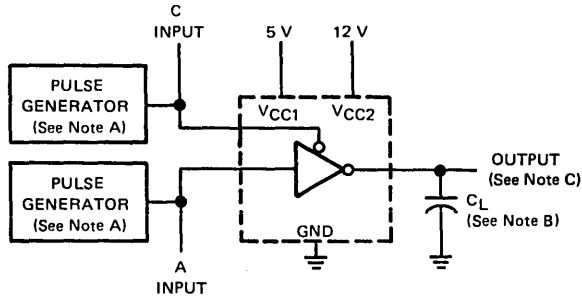

FIGURE 2—TEST CIRCUIT AND VOLTAGE WAVEFORMS FOR  $t_{pZH}$  AND  $t_{pZL}$

- NOTES: A. The pulse generators have the following characteristics: PRR = 1 MHz for A input, 2 MHz for C input,  $Z_{out} = 50 \Omega$ .  
 B.  $C_L$  includes probe and jig capacitance.  
 C. Waveforms are monitored on an oscilloscope with the following characteristics:  $t_r < 5 \text{ ns}$ ,  $R_{in} > 1 \text{ M}\Omega$ .



# TYPE SN75357

## QUADRUPLE TTL-TO-MOS DRIVER WITH 3-STATE OUTPUTS

### PARAMETER MEASUREMENT INFORMATION

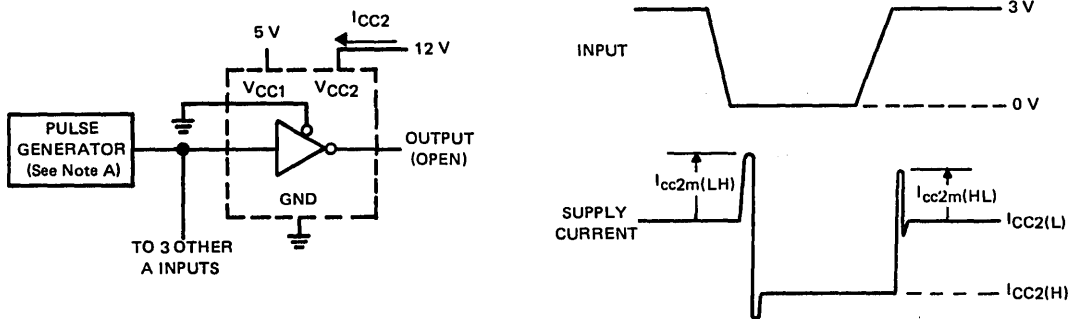
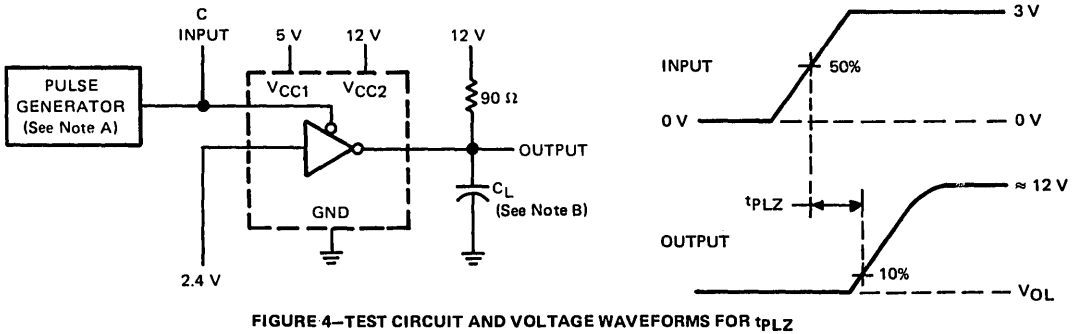
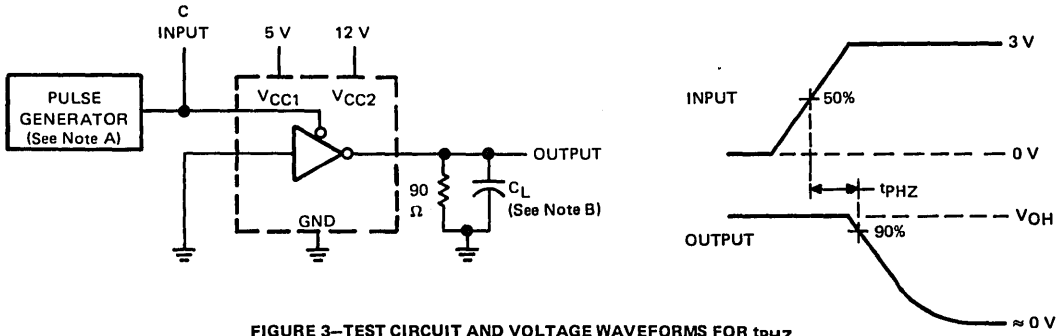

NOTES: A. The pulse generator has the following characteristics: PRR = 1 MHz,  $Z_{out} = 50 \Omega$ .  
 B.  $C_L$  includes probe and jig capacitance.

# INTERFACE CIRCUITS

# TYPE SN75361A DUAL NAND TTL-TO-MOS DRIVER

BULLETIN NO. DL-S 7712054, SEPTEMBER 1973—REVISED APRIL 1977

## MOS MEMORY INTERFACE

JG OR P  
DUAL-IN-LINE PACKAGE  
(TOP VIEW)

- Dual Positive-Logic NAND TTL-to-MOS Driver
- Versatile Interface Circuit for Use between TTL and High-Current, High-Voltage Systems
- Capable of Driving High-Capacitance Loads
- Compatible with Many Popular MOS RAMs
- VCC2 Supply Voltage Variable over Wide Range to 24 Volts Maximum
- TTL and DTL Compatible Diode-Clamped Inputs
- Operates from Standard Bipolar and MOS Supply Voltages
- High-Speed Switching
- Transient Overdrive Minimizes Power Dissipation
- Low Standby Power Dissipation

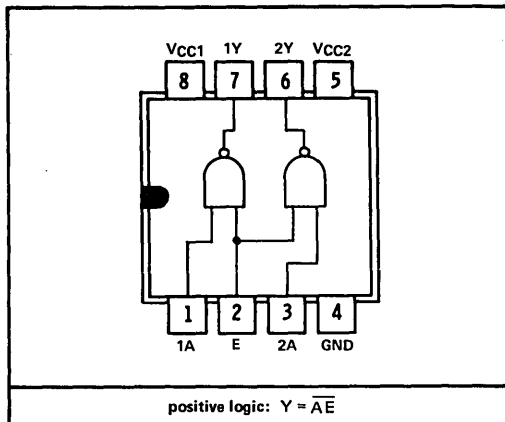

### description

The SN75361A is a monolithic integrated dual TTL-to-MOS driver and interface circuit. The device accepts standard TTL and DTL input signals and provides high-current and high-voltage output levels suitable for driving MOS circuits. Specifically, it may be used to drive address, control, and timing inputs for several types of MOS RAMs including the TMS 1103 and TMS 4062.

The SN75361A operates from the TTL 5-volt supply and the MOS VSS supply in many applications. This device has been optimized for operation with VCC2 supply voltage from 16 volts to 20 volts; however, it is designed so as to be useable over a much wider range of VCC2.

The SN75361A is characterized for operation from 0°C to 70°C.

### schematic (each driver)

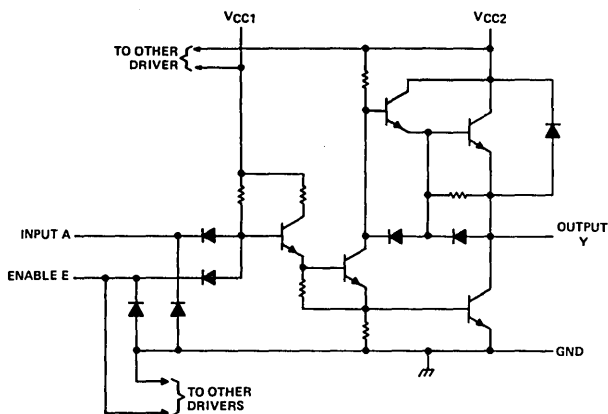

# TYPE SN75361A

## DUAL NAND TTL-TO-MOS DRIVER

---

**absolute maximum ratings over operating free-air temperature range (unless otherwise noted)**

Supply voltage range of $V_{CC1}$ (see Note 1)	-0.5 V to 7 V
Supply voltage range of $V_{CC2}$	-0.5 V to 25 V
Input voltage	5.5 V
Inter-input voltage (see Note 2)	5.5 V
Continuous total dissipation at (or below) 25°C free-air temperature (see Note 3):	
JG package	825 mW
P package	1000 mW
Operating free-air temperature range	0°C to 70°C
Storage temperature range	-65°C to 150°C
Lead temperature 1/16 inch from case for 60 seconds: JG package	300°C
Lead temperature 1/16 inch from case for 10 seconds: P package	260°C

- NOTES: 1. Voltage values are with respect to network ground terminal unless otherwise noted.  
 2. This rating applies between the A input of either driver and the common E input.  
 3. For operation above 25°C free-air temperature, refer to Dissipation Derating Curves in the Thermal Information section, which starts on page 2-1. In the JG package, SN75361A chips are glass-mounted.

**recommended operating conditions**

	MIN	NOM	MAX	UNIT
Supply voltage, $V_{CC1}$	4.75	5	5.25	V
Supply voltage, $V_{CC2}$	4.75	20	24	V
Operating free-air temperature, $T_A$	0		70	°C



# TYPE SN75361A

## DUAL NAND TTL-TO-MOS DRIVER

electrical characteristics over recommended ranges of  $V_{CC1}$ ,  $V_{CC2}$ , and operating free-air temperature (unless otherwise noted)

PARAMETER		TEST CONDITIONS		MIN	TYP†	MAX	UNIT
$V_{IH}$	High-level input voltage			2			V
$V_{IL}$	Low-level input voltage					0.8	V
$V_{IK}$	Input clamp voltage	$I_I = -12$ mA				-1.5	V
$V_{OH}$	High-level output voltage	$V_{IL} = 0.8$ V,	$I_{OH} = -50$ $\mu$ A	$V_{CC2}-1$	$V_{CC2}-0.7$		V
		$V_{IL} = 0.8$ V,	$I_{OH} = -10$ mA	$V_{CC2}-2.3$	$V_{CC2}-1.8$		
$V_{OL}$	Low-level output voltage	$V_{IH} = 2$ V,	$I_{OL} = 10$ mA	0.15		0.3	V
		$V_{CC2} = 15$ V to $24$ V, $V_{IH} = 2$ V, $I_{OL} = 40$ mA		0.25		0.5	V
$V_{OK}$	Output clamp voltage	$V_I = 0$ V,	$I_{OH} = 20$ mA			$V_{CC2}+1.5$	V
$I_I$	Input current at maximum input voltage	$V_I = 5.5$ V				1	mA
$I_{IH}$	High-level input current	$V_I = 2.4$ V	A inputs			40	$\mu$ A
			E input			80	
$I_{IL}$	Low-level input current	$V_I = 0.4$ V	A inputs	-1	-1.6	mA	
			E input	-2	-3.2		
$I_{CC1(H)}$	Supply current from $V_{CC1}$ , both outputs high	$V_{CC1} = 5.25$ V,	$V_{CC2} = 24$ V,	2		4	mA
$I_{CC2(H)}$	Supply current from $V_{CC2}$ , both outputs high	All inputs at 0 V, No load				0.5	
$I_{CC1(L)}$	Supply current from $V_{CC1}$ , both outputs low	$V_{CC1} = 5.25$ V,	$V_{CC2} = 24$ V,	16		24	mA
$I_{CC2(L)}$	Supply current from $V_{CC2}$ , both outputs low	All inputs at 5 V, No load		7		13	
$I_{CC2(S)}$	Supply current from $V_{CC2}$ , standby condition	$V_{CC1} = 0$ V, All inputs at 5 V,	$V_{CC2} = 24$ V, No load			0.5	mA

†All typical values are at  $V_{CC1} = 5$  V,  $V_{CC2} = 20$  V, and  $T_A = 25^\circ\text{C}$ .

switching characteristics,  $V_{CC1} = 5$  V,  $V_{CC2} = 20$  V,  $T_A = 25^\circ\text{C}$

PARAMETER		TEST CONDITIONS		MIN	TYP	MAX	UNIT	
$t_{DLH}$	Delay time, low-to-high-level output	$C_L = 390$ pF, $R_D = 10$ $\Omega$ , See Figure 1			11	24	ns	
$t_{DHL}$	Delay time, high-to-low-level output				10	20	ns	
$t_{TLH}$	Transition time, low-to-high-level output				25	40	ns	
$t_{THL}$	Transition time, high-to-low-level output				21	35	ns	
$t_{PLH}$	Propagation delay time, low-to-high-level output				10	36	55	ns
$t_{PHL}$	Propagation delay time, high-to-low-level output				10	31	47	ns

# TYPE SN75361A DUAL NAND TTL-TO-MOS DRIVER

## PARAMETER MEASUREMENT INFORMATION

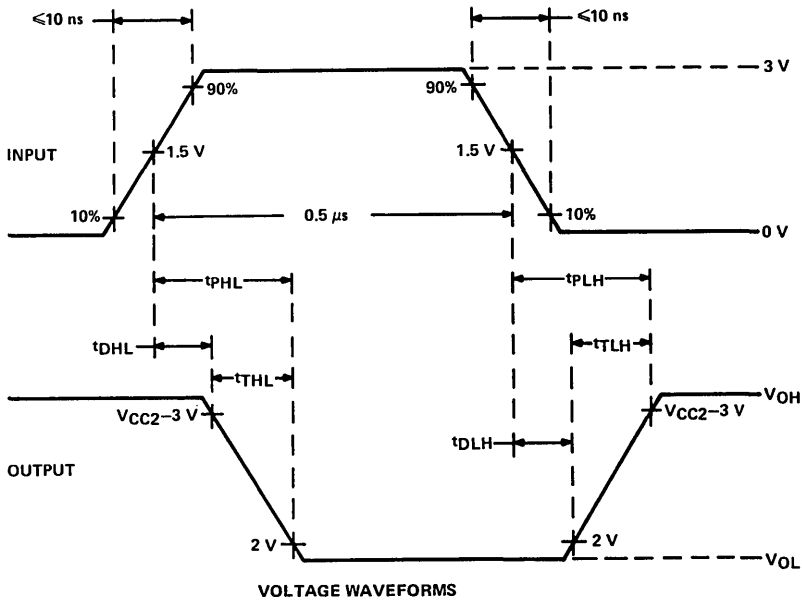
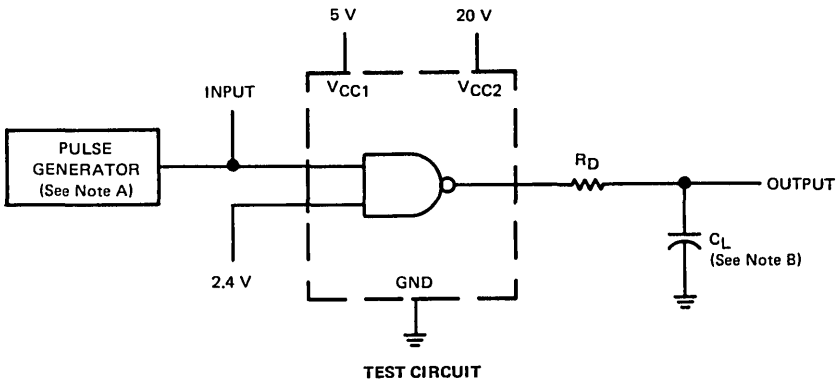

NOTES: A. The pulse generator has the following characteristics: PRR = 1 MHz,  $Z_{out} \approx 50 \Omega$ .  
 B.  $C_L$  includes probe and jig capacitance.

**FIGURE 1—SWITCHING TIMES, EACH DRIVER**

7

# TYPE SN75361A

## DUAL NAND TTL-TO-MOS DRIVER

### TYPICAL CHARACTERISTICS

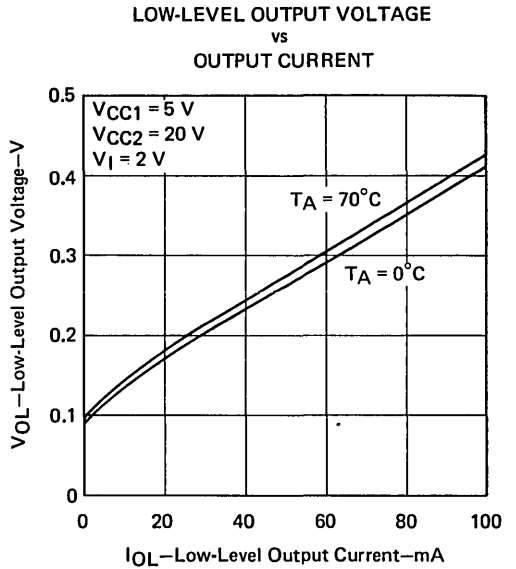
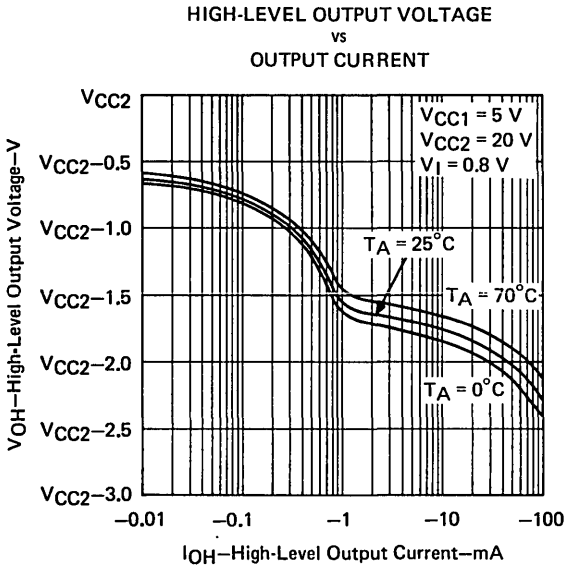

7

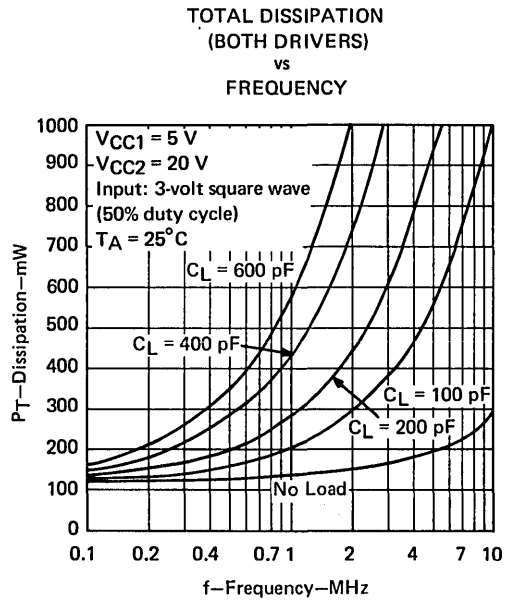
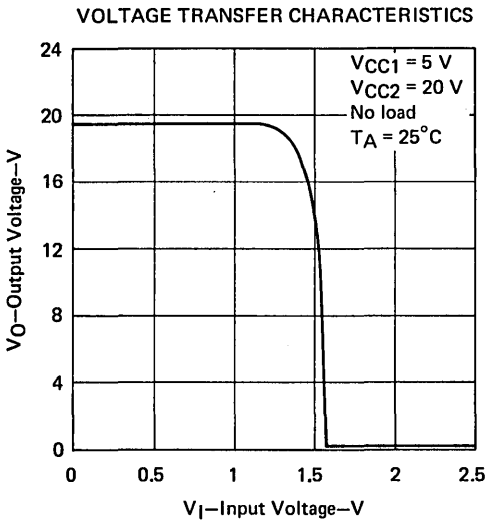

# TYPE SN75361A DUAL NAND TTL-TO-MOS DRIVER

## TYPICAL CHARACTERISTICS

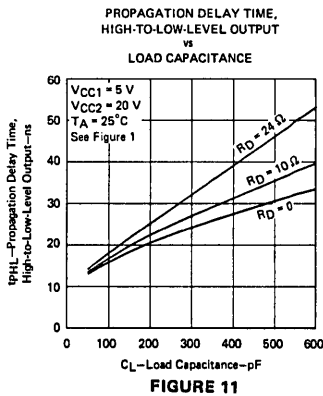
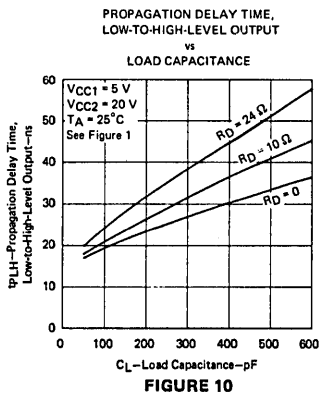
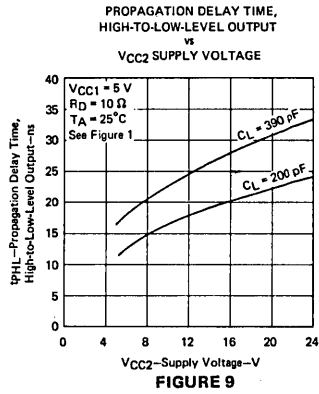
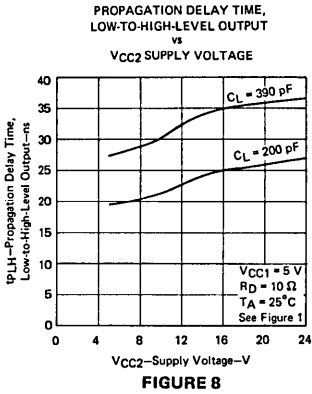
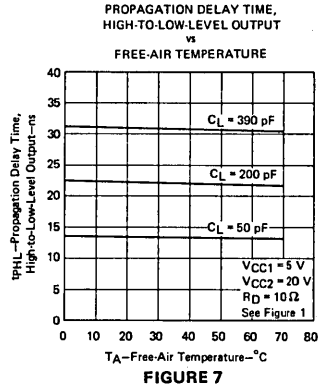
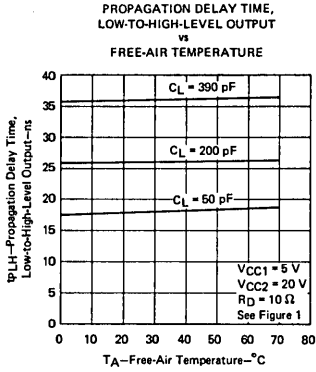

7

# TYPE SN75361A DUAL NAND TTL-TO-MOS DRIVER

## TYPICAL APPLICATION DATA

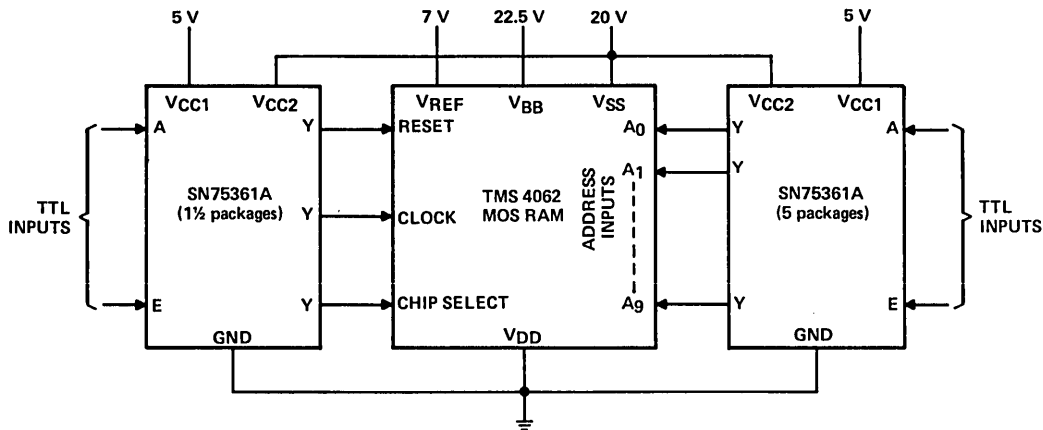

FIGURE 12—INTERCONNECTION OF SN75361A DEVICES WITH TMS4062-TYPE P-CHANNEL MOS RAM.

7

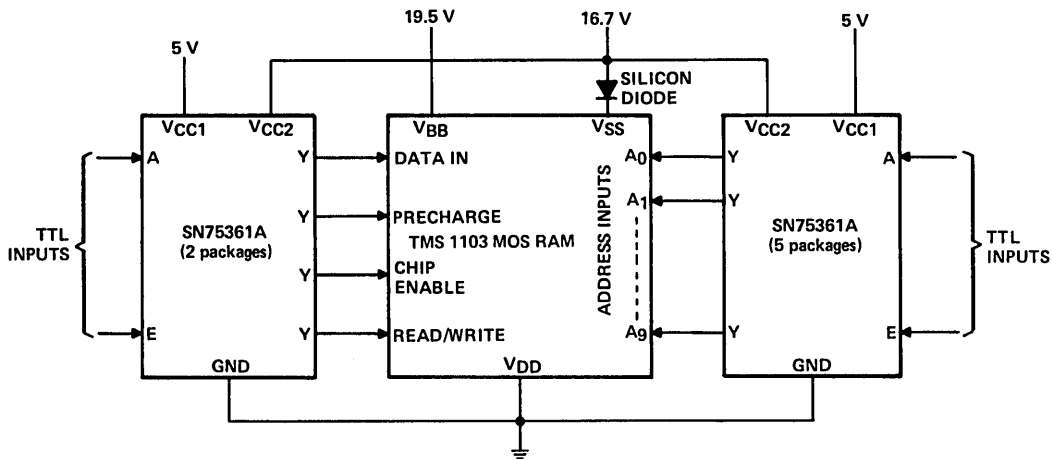

FIGURE 13—INTERCONNECTION OF SN75361A DEVICES WITH '1103-TYPE SILICON-GATE MOS RAM



# TYPE SN75361A DUAL NAND TTL-TO-MOS DRIVER

## TYPICAL APPLICATION DATA

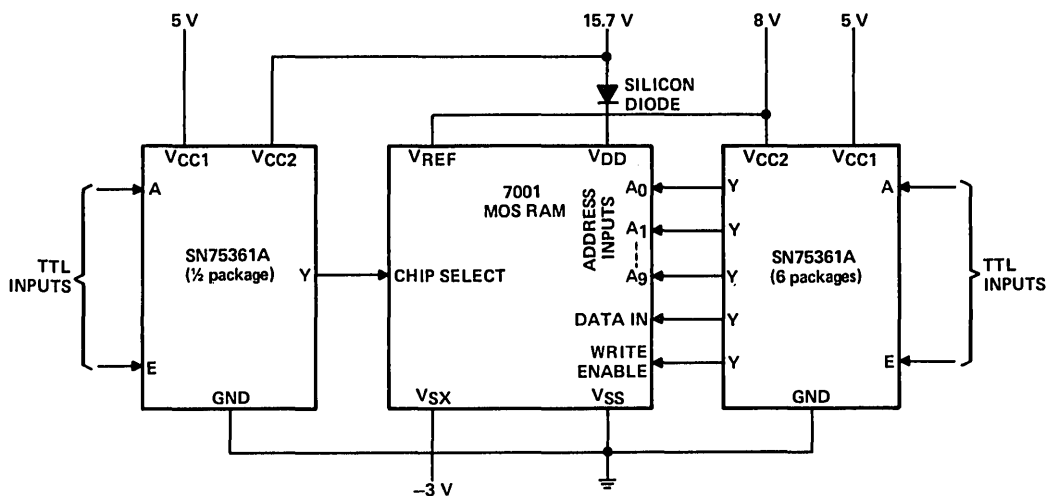
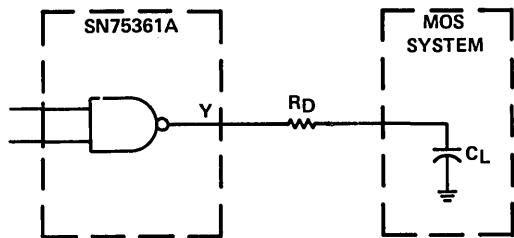

FIGURE 14—INTERCONNECTION OF SN75361A DEVICES WITH 7001-TYPE N-CHANNEL MOS RAM.



NOTE:  $R_D \approx 10 \Omega$  to  $30 \Omega$  (optional).

FIGURE 15—USE OF DAMPING RESISTOR TO REDUCE OR ELIMINATE OUTPUT TRANSIENT OVERSHOOT IN CERTAIN SN75361A APPLICATIONS

Applications using SN75361A as interface devices between TTL inputs and the address, control, and timing inputs for three types of MOS RAMs are shown in Figures 12, 13, and 14. A silicon diode is used in Figures 13 and 14 to increase the SN75361A high-level output voltage to obtain the desired high-level input voltage required by these MOS RAMs. An extra power supply could be used in place of the diode.

Figures 12, 13, and 14 show the use of the SN75361A over a wide range of  $V_{CC2}$  supply voltages. The device may even be used as a TTL gate, if desired, by connecting  $V_{CC2}$  to 5 volts.

The fast switching speeds of this device may produce undesirable output transient overshoot because of load or wiring inductance. A small series damping resistor may be used to reduce or eliminate this output transient overshoot. The optimum value of the damping resistor to use depends on the specific load characteristics and switching speed. A typical value would be between  $10 \Omega$  and  $30 \Omega$ . See Figure 15.

7

# TYPE SN75361A

## DUAL NAND TTL-TO-MOS DRIVER

### THERMAL INFORMATION

#### power dissipation precautions

Significant power may be dissipated in the SN75361A driver when charging and discharging high-capacitance loads over a wide voltage range at high frequencies. Figure 5 shows the power dissipated in a typical SN75361A as a function of load capacitance and frequency. Average power dissipated by this driver can be broken into three components:

$$P_T(AV) = P_{DC}(AV) + P_C(AV) + P_S(AV)$$

where  $P_{DC}(AV)$  is the steady-state power dissipation with the output high or low,  $P_C(AV)$  is the power level during charging or discharging of the load capacitance, and  $P_S(AV)$  is the power dissipation during switching between the low and high levels. None of these include energy transferred to the load and all are averaged over a full cycle.

The power components per driver channel are:

$$P_{DC}(AV) = \frac{P_L t_L + P_H t_H}{T}$$

$$P_C(AV) \approx C V_C^2 f$$

$$P_S(AV) = \frac{P_{LH} t_{LH} + P_{HL} t_{HL}}{T}$$

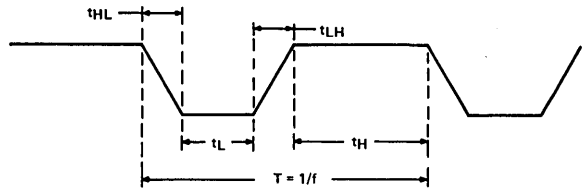

FIGURE 16—OUTPUT VOLTAGE WAVEFORM

where the times are as defined in Figure 16.

$P_L$ ,  $P_H$ ,  $P_{LH}$ , and  $P_{HL}$  are the respective instantaneous levels of power dissipation and  $C$  is load capacitance.

The SN75361A is so designed that  $P_S$  is a negligible portion of  $P_T$  in most applications. Except at very high frequencies,  $t_L + t_H \gg t_{LH} + t_{HL}$  so that  $P_S$  can be neglected. Figure 5 for no load demonstrates this point. The power dissipation contributions from both channels are then added together to obtain total device power.

The following example illustrates this power calculation technique. Assume both channels are operating identically with  $C = 200$  pF,  $f = 2$  MHz,  $V_{CC1} = 5$  V,  $V_{CC2} = 20$  V, and duty cycle = 60% outputs high ( $t_H/T = 0.6$ ). Also, assume  $V_{OH} = 19.3$  V,  $V_{OL} = 0.1$  V,  $P_S$  is negligible, and that the current from  $V_{CC2}$  is negligible when the output is high.

On a per-channel basis using data sheet values:

$$P_{DC}(AV) = \left[ (5 \text{ V}) \left( \frac{2 \text{ mA}}{2} \right) + (20 \text{ V}) \left( \frac{0 \text{ mA}}{2} \right) \right] (0.6) + \left[ (5 \text{ V}) \left( \frac{16 \text{ mA}}{2} \right) + (20 \text{ V}) \left( \frac{7 \text{ mA}}{2} \right) \right] (0.4)$$

$$P_{DC}(AV) = 47 \text{ mW per channel}$$

$$P_C(AV) \approx (200 \text{ pF}) (19.2 \text{ V})^2 (2 \text{ MHz})$$

$$P_C(AV) \approx 148 \text{ mW per channel.}$$

For the total device dissipation of the two channels:

$$P_T(AV) \approx 2 (47 + 148)$$

$$P_T(AV) \approx 390 \text{ mW typical for total package.}$$

**MOS MEMORY INTERFACE**

- Versatile Interface Circuit for Use between TTL and High-Current, High-Voltage Systems
- Capable of Driving High-Capacitance Loads
- Compatible with Many Popular MOS RAMs
- Operates from Standard Bipolar and MOS Supply Voltages
- High-Speed Switching
- TTL- and DTL-Compatible Inputs
- Separate Driver Address Inputs with Common Strobe
- VCC2 Supply Voltage Variable Over Wide Range
- VCC3 Supply Voltage Pin Available
- VCC3 Pin can be Connected to VCC2 Pin in Some Applications
- Damping Resistor Eliminates Undesired Output Transient Overshoot
- Transient Overdrive Improves Fall Time

J OR N  
DUAL-IN-LINE PACKAGE (TOP VIEW)

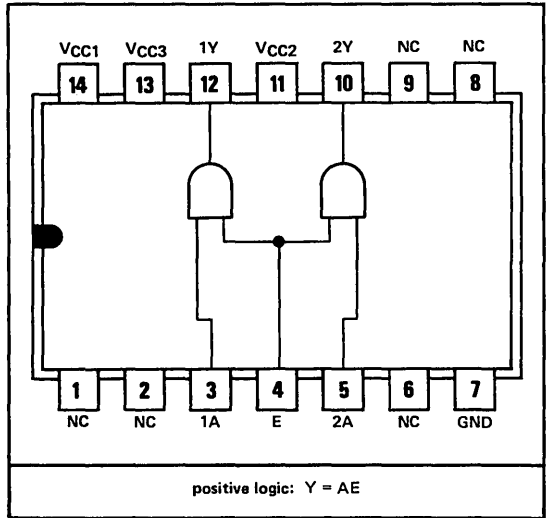

NC—No internal connection.

**description**

The SN75363 is a monolithic dual TTL-to-MOS driver and interface circuit. The device accepts standard TTL and DTL input signals and provides high-current high-voltage output levels suitable for driving MOS circuits. Specifically, it may be used to drive the chip-enable clock input of the TMS4030 MOS RAM and the address, control, and timing inputs for several other types of MOS RAMs.

The SN75363 operates from the TTL 5-volt supply and the MOS  $V_{SS}$  and  $V_{DD}$  supplies. This device has been optimized for operation with  $V_{CC2}$  supply voltage from 11 volts to 15 volts, and with nominal  $V_{CC3}$  supply voltage from 3 to 4 volts higher than  $V_{CC2}$ . In some applications the  $V_{CC3}$  power supply can be eliminated by connecting the  $V_{CC3}$  pin to the  $V_{CC2}$  pin.

A small series damping resistor has been included in the design to eliminate undesired output transient overshoot due to load or wiring inductance.

The SN75363 is characterized for operation from 0°C to 70°C.

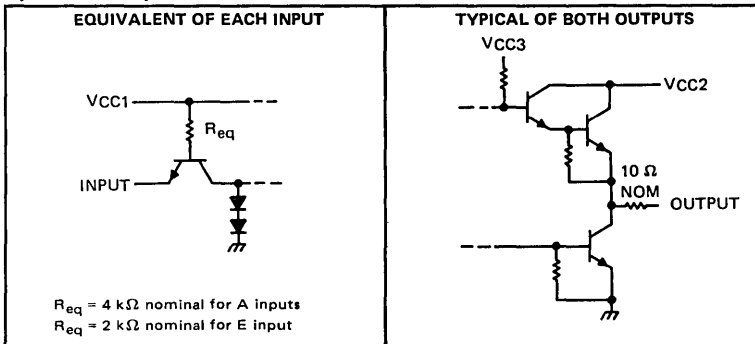

# TYPE SN75363

## DUAL POSITIVE-AND TTL-TO-MOS DRIVER

### absolute maximum ratings over operating free-air temperature range (unless otherwise noted)

Supply voltage range of $V_{CC1}$ (see Note 1)	−0.5 V to 7 V
Supply voltage range of $V_{CC2}$	−0.5 V to 16 V
Supply voltage range of $V_{CC3}$	−0.5 V to 19 V
Input voltage	5.5 V
Continuous total dissipation at (or below) 25°C free-air temperature (see Note 2): J package	1025 mW
N package	1150 mW
Operating free-air temperature range	0°C to 70°C
Storage temperature range	−65°C to 150°C
Lead temperature 1/16 inch from case for 60 seconds: J package	300°C
Lead temperature 1/16 inch from case for 10 seconds: N package	260°C

- NOTES: 1. Voltage values are with respect to network ground terminal unless otherwise noted.  
 2. For operation above 25°C free-air temperature, refer to Dissipation Derating Curves in the Thermal Information section, which starts on page 2-1. In the J package, SN75363 chips are glass-mounted.

### recommended operating conditions

	MIN	NOM	MAX	UNIT
Supply voltage, $V_{CC1}$	4.75	5	5.25	V
Supply voltage, $V_{CC2}$	4.75	12	15	V
Supply voltage, $V_{CC3}$	$V_{CC2}$	15	18	V
Voltage difference between supply voltages: $V_{CC3}-V_{CC2}$	0	3	4	V
Operating free-air temperature, $T_A$	0		70	°C

### electrical characteristics over recommended ranges of $V_{CC1}$ , $V_{CC2}$ , $V_{CC3}$ , and operating free-air temperature (unless otherwise noted)

PARAMETER		TEST CONDITIONS	MIN	TYP†	MAX	UNIT
$V_{IH}$	High-level input voltage		2			V
$V_{IL}$	Low-level input voltage				0.8	V
$V_{OH}$	High-level output voltage	$V_{CC2}+3V = V_{CC3}$ , $V_{IH} = 2V$ , $I_{OH} = -10mA$	$V_{CC2}-1.2$	$V_{CC2}-1.0$		V
		$V_{CC2}+3V = V_{CC3}$ , $V_{IH} = 2V$ , $I_{OH} = -100\mu A$	$V_{CC2}-0.3$	$V_{CC2}-0.15$		
$V_{OL}$	Low-level output voltage	$V_{CC2} = V_{CC3}$ , $V_{IH} = 2V$ , $I_{OH} = -50\mu A$	$V_{CC2}-1$	$V_{CC2}-0.7$		V
		$V_{CC2} = 10.8V$ , $V_{CC3} = 10.8V$ , $V_{IL} = 0.8V$ , $I_{OL} = 10mA$		0.3	0.5	
$I_i$	Input current at maximum input voltage	$V_i = 5.5V$			1	mA
$I_{IH}$	High-level input current	A inputs E input	$V_i = 2.4V$		40	$\mu A$
					80	
$I_{iL}$	Low-level input current	A inputs E input	$V_i = 0.4V$		−1	mA
					−3.2	
$I_{CC1(L)}$	Supply current from $V_{CC1}$ , both outputs low	$V_{CC1} = 5.25V$ , $V_{CC2} = 12V$ , $V_{CC3} = 12V$ , All inputs at 0V, No load		7	11	mA
$I_{CC2(L)}$	Supply current from $V_{CC2}$ , both outputs low	$V_{CC1} = 5V$ , $V_{CC2} = 15V$ , $V_{CC3} = 18V$		0.8	1.2	
$I_{CC3(L)}$	Supply current from $V_{CC3}$ , both outputs low	All inputs at 0V, No load		5	9	
$I_{CC1(H)}$	Supply current from $V_{CC1}$ , both outputs high	$V_{CC1} = 5.25V$ , $V_{CC2} = 12V$ , $V_{CC3} = 12V$ , All inputs at 5V, No load		17	25	mA
$I_{CC2(H)}$	Supply current from $V_{CC2}$ , both outputs high	$V_{CC1} = 5V$ , $V_{CC2} = 15V$ , $V_{CC3} = 18V$		−0.8	−1.2	
$I_{CC3(H)}$	Supply current from $V_{CC3}$ , both outputs high	All inputs at 5V, No load		0.8	1.2	

† All typical values are at  $V_{CC1} = 5V$ ,  $V_{CC2} = 12V$ ,  $V_{CC3} = 15V$ , and  $T_A = 25^\circ C$  except for  $V_{OH}$  for which  $V_{CC2}$  and  $V_{CC3}$  are as stated under test conditions.

# TYPE SN75363 DUAL POSITIVE-AND TTL-TO-MOS DRIVER

switching characteristics,  $V_{CC1} = 5\text{ V}$ ,  $V_{CC2} = 12\text{ V}$ ,  $V_{CC3} = 15\text{ V}$ ,  $T_A = 25^\circ\text{C}$

PARAMETER	TEST CONDITIONS	MIN	TYP	MAX	UNIT
$t_{DLH}$ Delay time, low-to-high-level output	$C_L = 300\text{ pF}$ , See Figure 1	7	12	17	ns
$t_{DHL}$ Delay time, high-to-low-level output		10	17	24	ns
$t_{TLH}$ Transition time, low-to-high-level output		10	16	22	ns
$t_{THL}$ Transition time, high-to-low-level output		10	16	22	ns
$t_{PLH}$ Propagation delay time, low-to-high-level output		17	28	39	ns
$t_{PHL}$ Propagation delay time, high-to-low-level output		20	33	46	ns

## PARAMETER MEASUREMENT INFORMATION

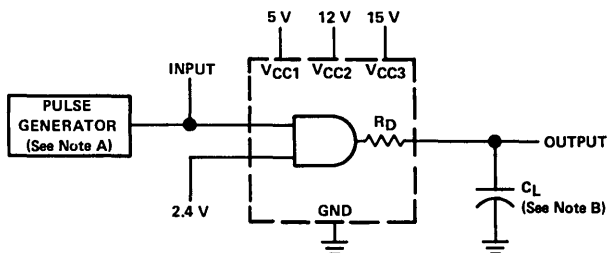

TEST CIRCUIT

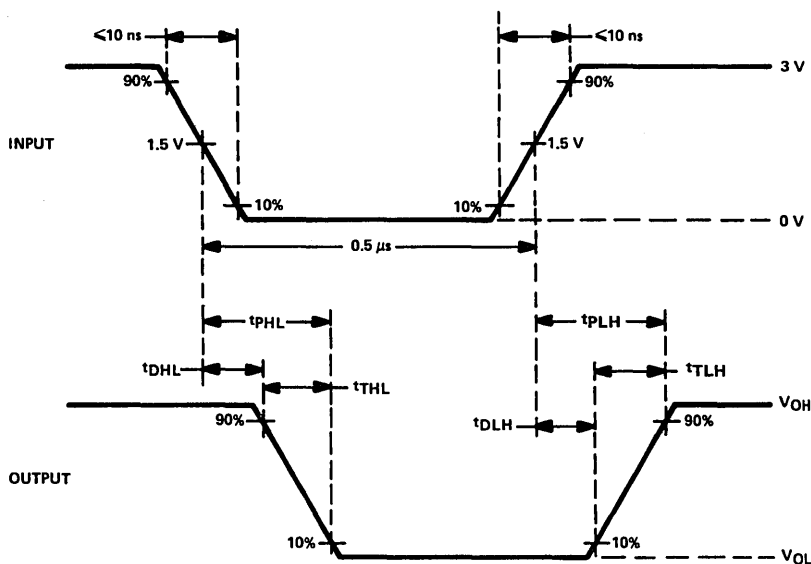

VOLTAGE WAVEFORMS

- NOTES: A. The pulse generator has the following characteristics: PRR = 1 MHz,  $Z_{out} \approx 50\ \Omega$ .  
 B.  $C_L$  includes probe and jig capacitance.

FIGURE 1—SWITCHING TIMES, EACH DRIVER

# TYPE SN75363 DUAL POSITIVE-AND TTL-TO-MOS DRIVER

## TYPICAL CHARACTERISTICS

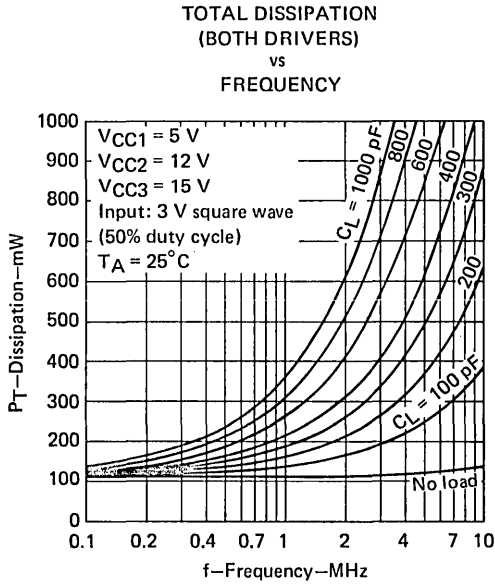

FIGURE 2

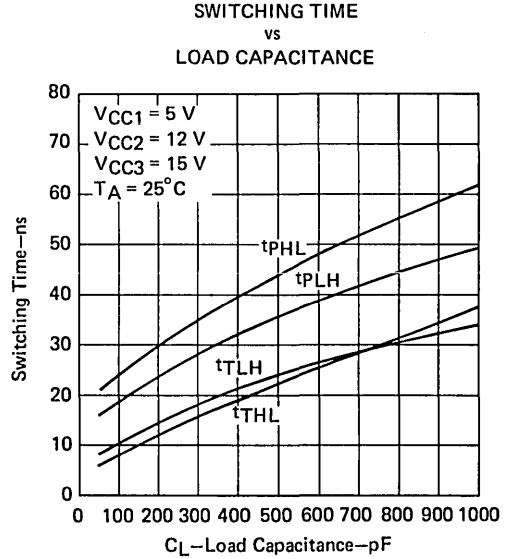

FIGURE 3

## TYPICAL APPLICATION DATA

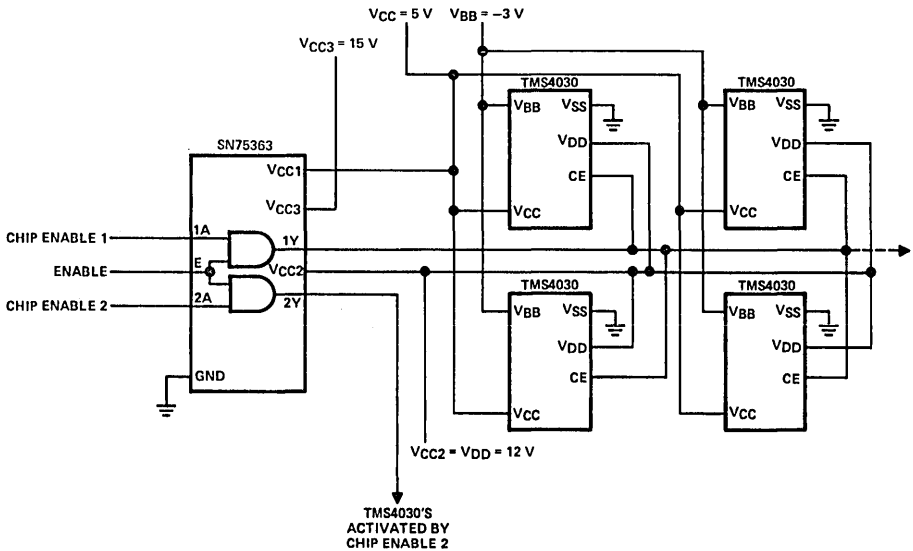

FIGURE 4—SN75363 DRIVING TMS4030 MEMORIES

# INTERFACE CIRCUITS

# TYPE SN75364 DUAL MOS DRIVER

BULLETIN NO. DL-S 7712373, APRIL 1976—REVISED APRIL 1977

## MOS MEMORY INTERFACE

- Dual Inverting MOS Driver
- Versatile Interface Circuit for Use Between TTL Levels and Level-Shifted High-Current, High-Voltage Systems
- Inputs May Be Level-Shifted by Use of a Current Source or Capacitive Coupling or Driven Directly by a Voltage Source
- Capable of Driving High-Capacitance Loads
- Compatible with Many Popular MOS RAMs and MOS Shift Registers
- $V_{CC2}$  Supply Voltage Variable over Wide Range to 22 Volts Maximum with Respect to  $V_{EE}$
- $V_{CC1}$  Pull-up Supply Voltage Pin Available
- $V_{CC1}$  Pin Can Be Connected to  $V_{CC2}$  Pin in Some Applications
- Operates from Standard Bipolar and/or MOS Supply Voltages
- High-Speed Switching
- Transient Overdrive Minimizes Power Dissipation
- Low Standby Power Dissipation

### description

The SN75364 is a monolithic dual MOS driver and interface circuit that operates with either current-source or voltage-source input signals. The device accepts appropriate level-shifted input signals from TTL or other logic systems and provides high-current and high-voltage output levels suitable for driving MOS circuits. Specifically, it may be used to drive address, control, and/or timing inputs for several types of MOS RAMs and MOS shift registers.

The SN75364 operates from standard MOS and/or bipolar supplies in most applications. This device has been optimized for operation with  $V_{CC2}$  supply voltage from 12 volts to 20 volts positive with respect to  $V_{EE}$ , and with nominal  $V_{CC1}$  supply voltage from 3 volts to 4 volts more positive than  $V_{CC2}$ . However, it is designed so as to be useable over a much wider range of  $V_{CC1}$  and  $V_{CC2}$ . In some applications the  $V_{CC1}$  power supply can be eliminated by connecting the  $V_{CC1}$  pin to the  $V_{CC2}$  pin.

Inputs of the SN75364 are referenced to the  $V_{EE}$  terminal and contain a series current-limiting resistor. The device will operate with either positive current input signals or voltage input signals that are positive with respect to  $V_{EE}$ . In many applications the  $V_{EE}$  terminal is connected to the MOS  $V_{DD}$  supply of -12 volts to -15 volts with the inputs to be driven from TTL levels or other positive voltage levels. The required negative-level shifting may be done with an external p-n-p transistor current source or by use of capacitive coupling and appropriate input voltage pulse characteristics.

The SN75364 is characterized for operation from 0°C to 70°C.

JG OR P  
DUAL-IN-LINE PACKAGE (TOP VIEW)

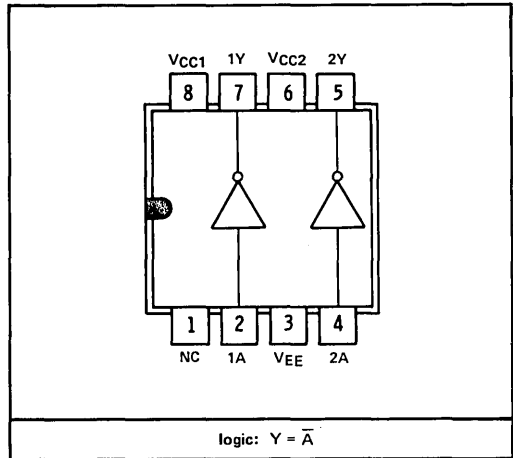

NC—No internal connection

### schematic (each driver)

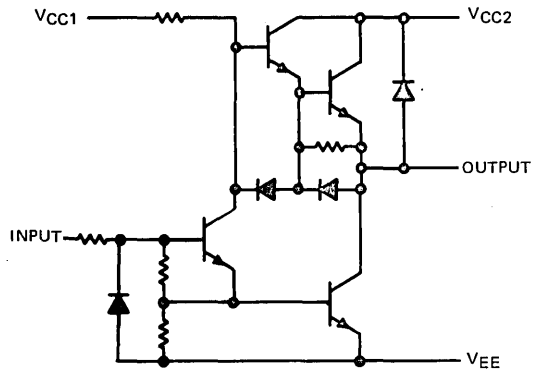

# TYPE SN75364

## DUAL MOS DRIVER

### absolute maximum ratings over operating free-air temperature range (unless otherwise noted)

Supply voltage range of $V_{CC1}$ (see Note 1)	-0.5 V to 30 V
Supply voltage range of $V_{CC2}$	-0.5 V to 22 V
Input voltage	20 V
Positive voltage at any input with respect to $V_{CC1}$	0.5 V
Continuous total dissipation at (or below) 25°C free-air temperature (see Note 2):	
JG package	825 mW
P package	1000 mW
Operating free-air temperature range	0°C to 70°C
Storage temperature range	-65°C to 150°C
Lead temperature 1/16 inch from case for 60 seconds: JG package	300°C
Lead temperature 1/16 inch from case for 10 seconds: P package	260°C

- NOTES: 1. Voltage values are with respect to the  $V_{EE}$  terminal unless otherwise noted.  
 2. For operation above 25°C free-air temperature, refer to Dissipation Derating Curves in the Thermal Information section, which starts on page 2-1. In the JG package, SN75364 chips are glass-mounted.

### recommended operating conditions

	MIN	NOM	MAX	UNIT
Supply voltage, $V_{CC1}$	$V_{CC2}$	24	28	V
Supply voltage, $V_{CC2}$	4.75	20	22	V
Voltage difference between supply voltages: $V_{CC1}-V_{CC2}$	0	4	10	V
Input voltage			10	V
Operating free-air temperature, $T_A$	0		70	°C

7

### definition of input logic levels

PARAMETER	MIN	MAX	UNIT
$V_{IH}$ High-level input voltage	5	10	V
$V_{IL}$ Low-level input voltage		1	V
$I_{IH}$ High-level input current	8	15	mA
$I_{IL}$ Low-level input current		0.7	mA



# TYPE SN75364 DUAL MOS DRIVER

electrical characteristics over recommended ranges of  $V_{CC1}$ ,  $V_{CC2}$ , and operating free-air temperature (unless otherwise noted)

PARAMETER		TEST CONDITIONS (See Note 3)	MIN	TYP†	MAX	UNIT
V <sub>OH</sub>	High-level output voltage	$V_{CC1} = V_{CC2} + 3\text{ V}$ , $V_{IL} = 1\text{ V}$ , $I_{OH} = -100\ \mu\text{A}$	$V_{CC2} - 0.3$		$V_{CC2} - 0.1$	V
		$V_{CC1} = V_{CC2} + 3\text{ V}$ , $I_{IL} = 0.7\text{ mA}$ , $I_{OH} = -100\ \mu\text{A}$				
		$V_{CC1} = V_{CC2} + 3\text{ V}$ , $V_{IL} = 1\text{ V}$ , $I_{OH} = -10\text{ mA}$	$V_{CC2} - 1.2$		$V_{CC2} - 0.9$	
		$V_{CC1} = V_{CC2}$ , $V_{IL} = 1\text{ V}$ , $I_{OH} = -50\ \mu\text{A}$	$V_{CC2} - 1$		$V_{CC2} - 0.7$	
		$V_{CC1} = V_{CC2}$ , $I_{IL} = 0.7\text{ mA}$ , $I_{OH} = -50\ \mu\text{A}$				
		$V_{CC1} = V_{CC2}$ , $V_{IL} = 1\text{ V}$ , $I_{OH} = -10\text{ mA}$	$V_{CC2} - 2.3$		$V_{CC2} - 1.8$	
V <sub>OL</sub>	Low-level output voltage	$V_{IH} = 5\text{ V}$ , $I_{OL} = 10\text{ mA}$			0.15	V
		$I_{IH} = 8\text{ mA}$ , $I_{OL} = 10\text{ mA}$				
		$V_{CC1} = 15\text{ V to }28\text{ V}$ , $V_{IH} = 5\text{ V}$ , $I_{OL} = 40\text{ mA}$			0.25	
		$V_{CC1} = 15\text{ V to }28\text{ V}$ , $I_{IH} = 8\text{ mA}$ , $I_{OL} = 40\text{ mA}$			0.5	
V <sub>OK</sub>	Output clamp voltage	$V_I = 0\text{ V}$ , $I_{OH} = 20\text{ mA}$			$V_{CC2} + 1.5$	V
V <sub>I</sub>	Input voltage	$V_{CC1} = 13.5\text{ V to }28\text{ V}$ , $I_I = 15\text{ mA}$			9	V
		$I_I = 8\text{ mA}$			5.5	
		$I_I = 0.7\text{ mA}$			0.7	
I <sub>I</sub>	Input current	$V_{CC1} = 10\text{ V to }28\text{ V}$ , $V_I = 10\text{ V}$			17	mA
		$V_I = 5\text{ V}$			7	
		$V_I = 1\text{ V}$			1.1	
I <sub>CC1(H)</sub>	Supply current from $V_{CC1}$ , both outputs high	$V_{CC1} = 26\text{ V}$ , $V_{CC2} = 22\text{ V}$			1.0	mA
I <sub>CC2(H)</sub>	Supply current from $V_{CC2}$ , both outputs high	Both inputs at 0 V, No load			-1.0	
I <sub>CC1(L)</sub>	Supply current from $V_{CC1}$ , both outputs low	$V_{CC1} = 28\text{ V}$ , $V_{CC2} = 22\text{ V}$			7	mA
I <sub>CC2(L)</sub>	Supply current from $V_{CC2}$ , both outputs low	Both inputs at 7 V, No load			0.5	
I <sub>CC1(H)</sub>	Supply current from $V_{CC1}$ , both outputs high	$V_{CC1} = 22\text{ V}$ , $V_{CC2} = 22\text{ V}$			0.5	mA
I <sub>CC2(H)</sub>	Supply current from $V_{CC2}$ , both outputs high	Both inputs at 0 V, No load			0.25	

† All typical values are at  $V_{CC1} = 24\text{ V}$ ,  $V_{CC2} = 20\text{ V}$ , and  $T_A = 25^\circ\text{C}$  except for  $V_{OH}$  for which  $V_{CC1}$  and  $V_{CC2}$  are as stated under test conditions.

NOTE 3: Many of these parameters are specified independently for either voltage source or current source external forcing functions at the inputs. Use the appropriate set of specifications for each application.

switching characteristics,  $V_{CC2} = 20\text{ V}$ ,  $T_A = 25^\circ\text{C}$

PARAMETER	TEST CONDITIONS	$V_{CC1} = 24\text{ V}$			$V_{CC1} = 20\text{ V}$			UNIT
		MIN	TYP	MAX	MIN	TYP	MAX	
t <sub>DLH</sub>	Delay time, low-to-high-level output	2	13	23	3	14	24	ns
t <sub>DHL</sub>	Delay time, high-to-low-level output	1	9	18	1	10	18	ns
t <sub>TLH</sub>	Transition time, low-to-high-level output	8	21	24	8	21	34	ns
t <sub>THL</sub>	Transition time, high-to-low-level output	6	19	30	5	18	29	ns
t <sub>PLH</sub>	Propagation delay time, low-to-high-level output	10	34	57	11	35	58	ns
t <sub>PHL</sub>	Propagation delay time, high-to-low-level output	8	28	47	8	28	47	ns

# TYPE SN75364 DUAL MOS DRIVER

## PARAMETER MEASUREMENT INFORMATION

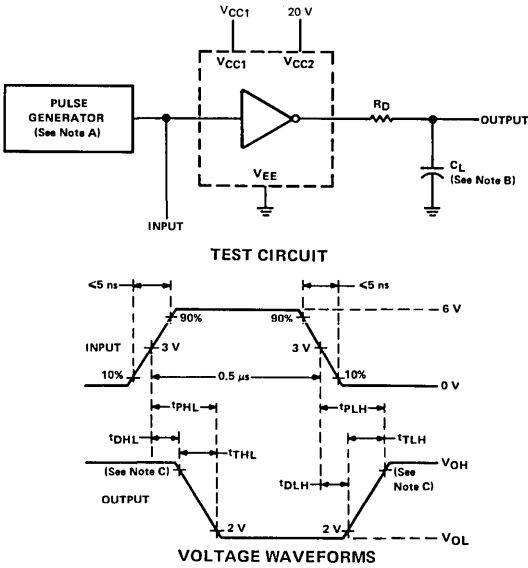

- NOTES: A. The pulse generator has the following characteristics:  
 PRR = 1 MHz,  $Z_{out} \approx 50 \Omega$ .  
 B.  $C_L$  includes probe and jig capacitance.  
 C. The high-level reference point is 17 V when  $V_{CC1} = V_{CC2} = 20$  V and is 18 V when  $V_{CC1} = V_{CC2} + 4$  V = 24 V.

FIGURE 1—SWITCHING TIMES, EACH DRIVER

## TYPICAL CHARACTERISTICS

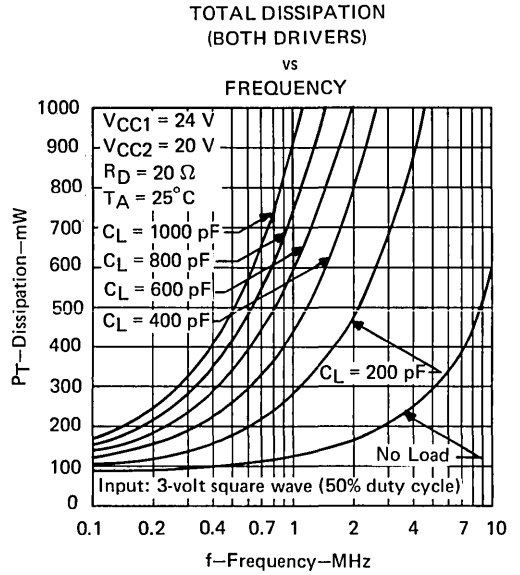
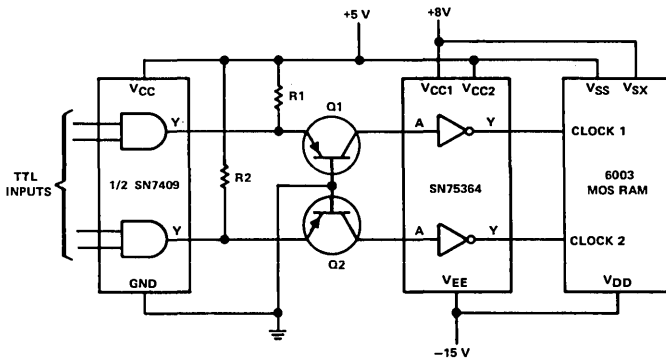

FIGURE 2

## TYPICAL APPLICATION DATA



- NOTES: R1 and R2  $\approx 350 \Omega$  to  $500 \Omega$ .  
 Q1 and Q2 are 2N3829 or similar p-n-p transistors.

FIGURE 3—MOS RAM CLOCK DRIVER SYSTEM WITH P-N-P TRANSISTOR CURRENT SOURCE USED TO LEVEL-SHIFT TO INPUTS OF SN75364

# TYPE SN75364 DUAL MOS DRIVER

## TYPICAL APPLICATION DATA

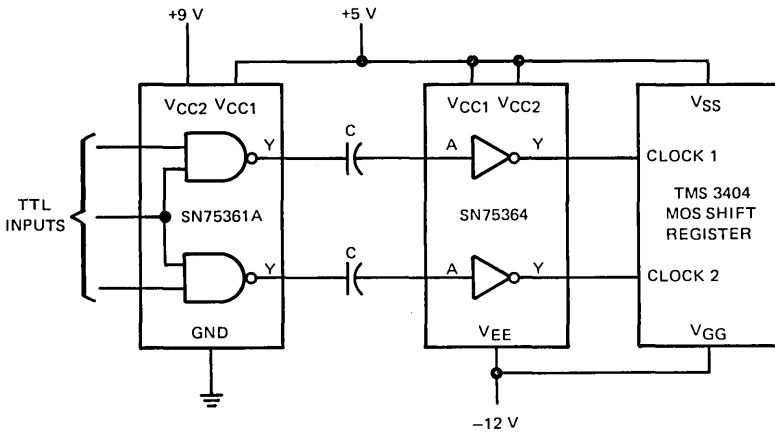
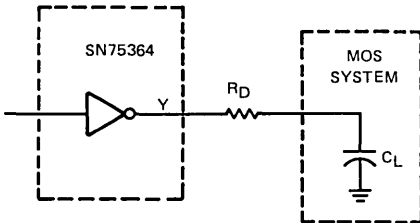

FIGURE 4—MOS SHIFT REGISTER CLOCK DRIVER SYSTEM WITH CAPACITIVE COUPLING USED TO LEVEL-SHIFT TO INPUTS OF SN75364



NOTE:  $R_D \approx 10 \Omega$  to  $30 \Omega$  (optional)

FIGURE 5—USE OF DAMPING RESISTOR TO REDUCE OR ELIMINATE OUTPUT TRANSIENT OVERSHOOT IN CERTAIN SN75364 APPLICATIONS

Applications of the SN75364 used as an interface device in systems converting TTL signals to negative polarity MOS clock signals are shown in Figures 3 and 4. In both applications the SN75364 VEE pin is connected to a negative MOS supply voltage. The VCC1 supply pin may be connected to the VCC2 pin as shown in Figure 4 or connected to a separate voltage more positive than VCC2, as shown in Figure 3. The SN75364 may be used over a wide range of VCC1 and VCC2 supply voltage. However, for proper operation, the voltage at the inputs of the SN75364 should not be more positive than the voltage at VCC1.

Both applications shown require negative level shifting from positive voltage levels to the inputs of the SN75364, which are referenced to the VEE terminal. A p-n-p transistor current source is used to level shift in Figure 3. Resistor R sets the current and an open-collector TTL gate is used to switch the p-n-p transistor. Figure 4 shows capacitive coupling being used to level shift with the SN75361A TTL-to-MOS driver used as a low-impedance voltage-source driver. The value of coupling capacitor C depends on the frequency and characteristics of the signal applied to the capacitor.

The fast switching speeds of the SN75364 may produce undesirable output transient overshoot because of load or wiring inductance. A small series damping resistor may be used to reduce or eliminate this output transient overshoot. The optimum value of the damping resistor depends on the specific load characteristics and switching speed. A typical value would be between  $10 \Omega$  and  $30 \Omega$ . See Figure 5.

7

# INTERFACE CIRCUITS

# TYPE SN75365 QUADRUPLE NAND TTL-TO-MOS DRIVER

BULLETIN NO. DLS 7712058, SEPTEMBER 1973—REVISED APRIL 1977

## MOS MEMORY INTERFACE

- Quad Positive-Logic NAND TTL-to-MOS Driver
- Versatile Interface Circuit for Use between TTL and High-Current, High-Voltage Systems
- Capable of Driving High-Capacitance Loads
- Compatible with Many Popular MOS RAMs
- Designed to be Interchangeable with Intel 3207
- $V_{CC2}$  Supply Voltage Variable over Wide Range to 24 Volts Maximum
- $V_{CC3}$  Supply Voltage Pin Available
- $V_{CC3}$  Pin Can Be Connected to  $V_{CC2}$  Pin in Some Applications
- TTL and DTL Compatible Diode-Clamped Inputs
- Operates from Standard Bipolar and MOS Supply Voltages
- Two Common Enable Inputs per Gate-Pair
- High-Speed Switching
- Transient Overdrive Minimizes Power Dissipation
- Low Standby Power Dissipation

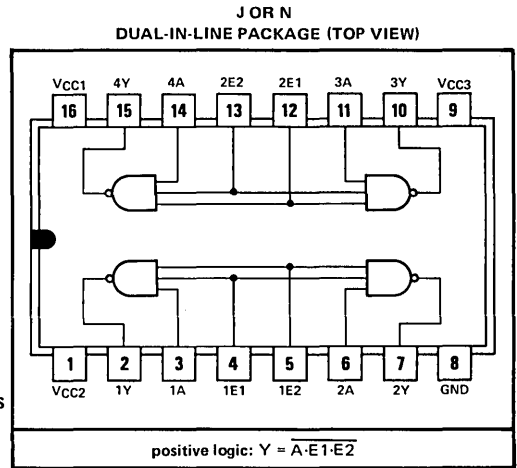

## description

The SN75365 is a monolithic integrated quadruple TTL-to-MOS driver and interface circuit. The device accepts standard TTL and DTL input signals and provides high-current and high-voltage output levels suitable for driving MOS circuits. Specifically, it may be used to drive address, control, and timing inputs for several types of MOS RAMs including the TMS1103 and TMS4062.

The SN75365 operates from the TTL 5-volt supply and the MOS  $V_{SS}$  and  $V_{BB}$  supplies in many applications. This device has been optimized for operation with  $V_{CC2}$  supply voltage from 16 volts to 20 volts, and with nominal  $V_{CC3}$  supply voltage from 3 volts to 4 volts higher than  $V_{CC2}$ . However, it is designed so as to be useable over a much wider range of  $V_{CC2}$  and  $V_{CC3}$ . In some applications the  $V_{CC3}$  power supply can be eliminated by connecting the  $V_{CC3}$  pin to the  $V_{CC2}$  pin.

The SN75365 is characterized for operation from 0°C to 70°C.

## schematic (each driver)

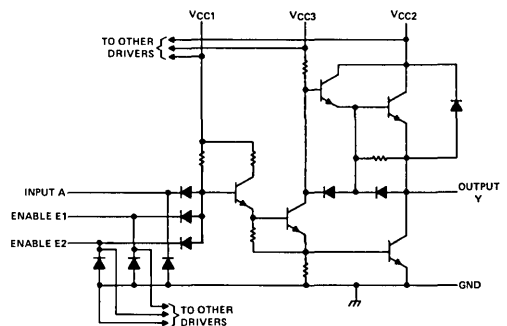

# TYPE SN75365

## QUADRUPLE NAND TTL-TO-MOS DRIVER

---

**absolute maximum ratings over operating free-air temperature range (unless otherwise noted)**

Supply voltage range of $V_{CC1}$ (see Note 1)	-0.5 V to 7 V
Supply voltage range of $V_{CC2}$	-0.5 V to 25 V
Supply voltage range of $V_{CC3}$	-0.5 V to 30 V
Input voltage	5.5 V
Inter-input voltage (see Note 2)	5.5 V
Continuous total dissipation at (or below) 25°C free-air temperature (see Note 3)	J package . . . . . 1025 mW
	N package . . . . . 1150 mW
Operating free-air temperature range	0°C to 70°C
Storage temperature range	-65°C to 150°C
Lead temperature 1/16 inch from case for 60 seconds: J package	300°C
Lead temperature 1/16 inch from case for 10 seconds: N package	260°C

- NOTES: 1. Voltage values are with respect to network ground terminal unless otherwise noted.  
 2. This rating applies between any two inputs of any one of the gates.  
 3. For operation above 25°C free-air temperature, refer to Dissipation Derating Curves in the Thermal Information section, which starts on page 2-1. In the J package, SN75365 chips are glass-mounted.

**recommended operating conditions**

	MIN	NOM	MAX	UNIT
Supply voltage, $V_{CC1}$	4.75	5	5.25	V
Supply voltage, $V_{CC2}$	4.75	20	24	V
Supply voltage, $V_{CC3}$	$V_{CC2}$	24	28	V
Voltage difference between supply voltages: $V_{CC3}-V_{CC2}$	0	4	10	V
Operating free-air temperature, $T_A$	0		70	°C



# TYPE SN75365

## QUADRUPLE NAND TTL-TO-MOS DRIVER

electrical characteristics over recommended ranges of  $V_{CC1}$ ,  $V_{CC2}$ ,  $V_{CC3}$  and operating free-air temperature (unless otherwise noted)

PARAMETER	TEST CONDITIONS	MIN	TYP <sup>†</sup>	MAX	UNIT
$V_{IH}$ High-level input voltage		2			V
$V_{IL}$ Low-level input voltage				0.8	V
$V_{IK}$ Input clamp voltage	$I_I = -12$ mA			-1.5	V
$V_{OH}$ High-level output voltage	$V_{CC3} = V_{CC2} + 3$ V, $V_{IL} = 0.8$ V, $I_{OH} = -100$ $\mu$ A	$V_{CC2}-0.3$	$V_{CC2}-0.1$		V
	$V_{CC3} = V_{CC2} + 3$ V, $V_{IL} = 0.8$ V, $I_{OH} = -10$ mA	$V_{CC2}-1.2$	$V_{CC2}-0.9$		
	$V_{CC3} = V_{CC2}$ , $V_{IL} = 0.8$ V, $I_{OH} = -50$ $\mu$ A	$V_{CC2}-1$	$V_{CC2}-0.7$		
	$V_{CC3} = V_{CC2}$ , $V_{IL} = 0.8$ V, $I_{OH} = -10$ mA	$V_{CC2}-2.3$	$V_{CC2}-1.8$		
$V_{OL}$ Low-level output voltage	$V_{IH} = 2$ V, $I_{OL} = 10$ mA		0.15	0.3	V
	$V_{CC3} = 15$ V to 28 V, $V_{IH} = 2$ V, $I_{OL} = 40$ mA		0.25	0.5	
$V_{OK}$ Output clamp voltage	$V_I = 0$ V, $I_{OH} = 20$ mA			$V_{CC2}+1.5$	V
$I_I$ Input current at maximum input voltage	$V_I = 5.5$ V			1	mA
$I_{IH}$ High-level input current	$V_I = 2.4$ V	A inputs		40	$\mu$ A
		E1 and E2 inputs		80	
$I_{IL}$ Low-level input current	$V_I = 0.4$ V	A inputs	-1	-1.6	mA
		E1 and E2 inputs	-2	-3.2	
$I_{CC1(H)}$ Supply current from $V_{CC1}$ , all outputs high	$V_{CC1} = 5.25$ V, $V_{CC2} = 24$ V, $V_{CC3} = 28$ V, No load		4	8	mA
$I_{CC2(H)}$ Supply current from $V_{CC2}$ , all outputs high			-2.2	+0.25 -3.2	
$I_{CC3(H)}$ Supply current from $V_{CC3}$ , all outputs high			2.2	3.5	
$I_{CC1(L)}$ Supply current from $V_{CC1}$ , all outputs low	$V_{CC1} = 5.25$ V, $V_{CC2} = 24$ V, $V_{CC3} = 28$ V, No load		31	47	mA
$I_{CC2(L)}$ Supply current from $V_{CC2}$ , all outputs low				2	
$I_{CC3(L)}$ Supply current from $V_{CC3}$ , all outputs low			16	27	
$I_{CC2(H)}$ Supply current from $V_{CC2}$ , all outputs high	$V_{CC1} = 5.25$ V, $V_{CC2} = 24$ V, $V_{CC3} = 24$ V, No load			0.25	mA
$I_{CC3(H)}$ Supply current from $V_{CC3}$ , all outputs high				0.5	
$I_{CC2(S)}$ Supply current from $V_{CC2}$ , standby condition	$V_{CC1} = 0$ V, $V_{CC2} = 24$ V, $V_{CC3} = 24$ V, No load			0.25	mA
$I_{CC3(S)}$ Supply current from $V_{CC3}$ , standby condition				0.5	

<sup>†</sup>All typical values are at  $V_{CC1} = 5$  V,  $V_{CC2} = 20$  V,  $V_{CC3} = 24$  V, and  $T_A = 25^\circ$  C except for  $V_{OH}$  for which  $V_{CC2}$  and  $V_{CC3}$  are as stated under test conditions.

switching characteristics,  $V_{CC1} = 5$  V,  $V_{CC2} = 20$  V,  $V_{CC3} = 24$  V,  $T_A = 25^\circ$  C

PARAMETER	TEST CONDITIONS	MIN	TYP	MAX	UNIT	
$t_{DLH}$ Delay time, low-to-high-level output	$C_L = 200$ pF, $R_D = 24$ $\Omega$ , See Figure 1		11	20	ns	
$t_{DHL}$ Delay time, high-to-low-level output			10	18	ns	
$t_{TLH}$ Transition time, low-to-high-level output				20	33	ns
$t_{THL}$ Transition time, high-to-low-level output				20	33	ns
$t_{PLH}$ Propagation delay time, low-to-high-level output			10	31	48	ns
$t_{PHL}$ Propagation delay time, high-to-low-level output			10	30	46	ns

# TYPE SN75365 QUADRUPLE NAND TTL-TO-MOS DRIVER

## PARAMETER MEASUREMENT INFORMATION

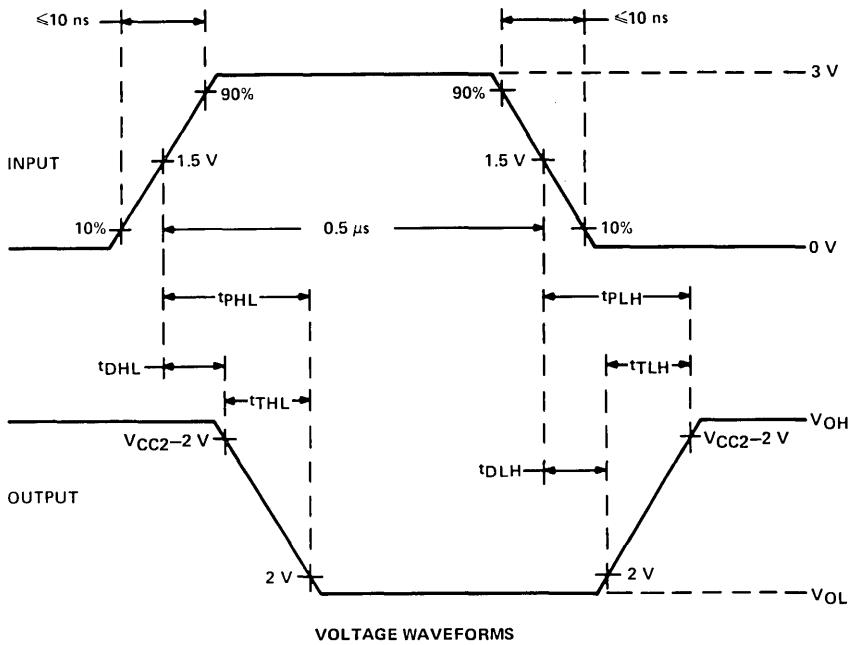
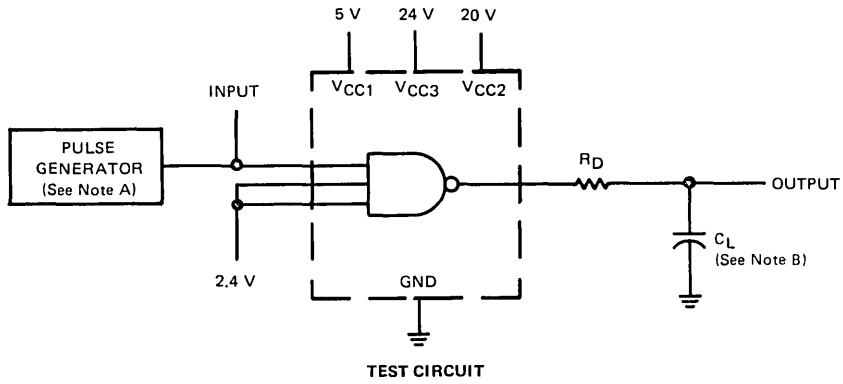

NOTES: A. The pulse generator has the following characteristics: PRR = 1 MHz,  $Z_{out} \approx 50 \Omega$ .  
 B.  $C_L$  includes probe and jig capacitance.

**FIGURE 1—SWITCHING TIMES, EACH DRIVER**

# TYPE SN75365 QUADRUPLE NAND TTL-TO-MOS DRIVER

## TYPICAL CHARACTERISTICS

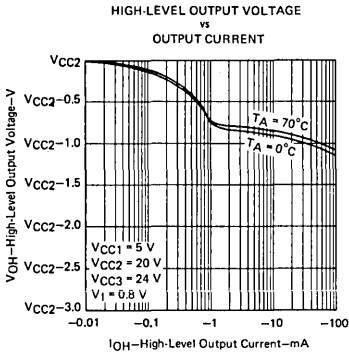

FIGURE 2

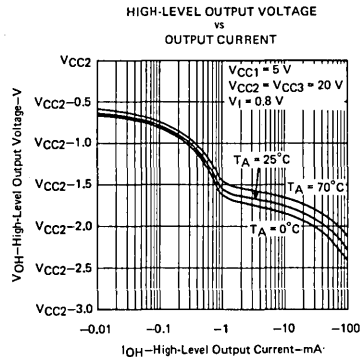

FIGURE 3

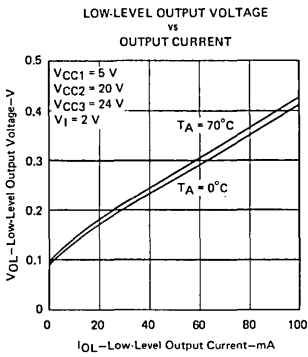

FIGURE 4

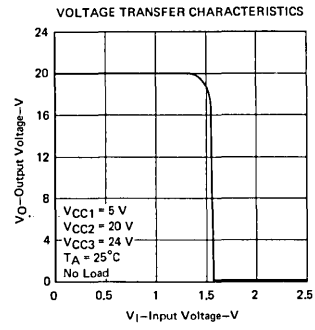

FIGURE 5

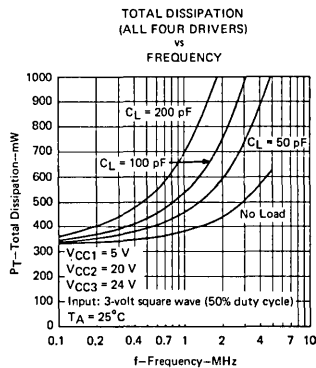

FIGURE 6



# TYPE SN75365

## QUADRUPLE NAND TTL-TO-MOS DRIVER

### TYPICAL CHARACTERISTICS

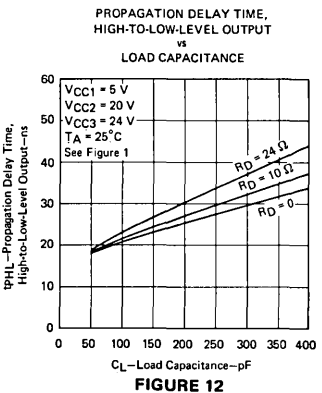
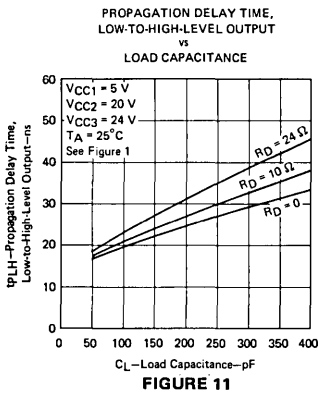
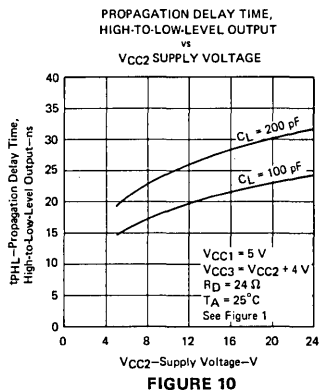
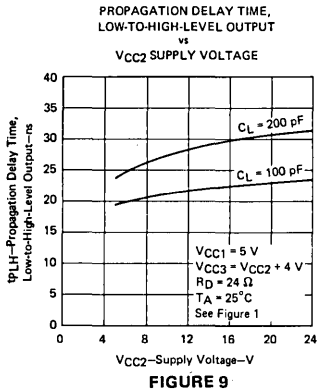
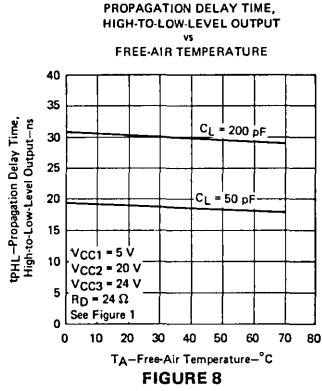
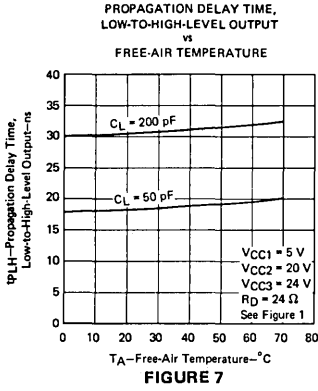

7

# TYPE SN75365 QUADRUPLE NAND TTL-TO-MOS DRIVER

## TYPICAL APPLICATION DATA

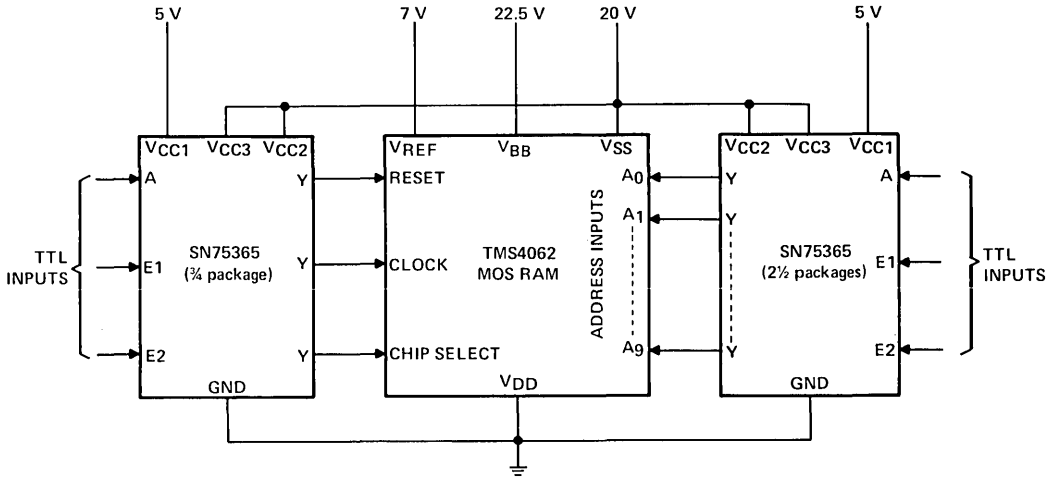

FIGURE 13—INTERCONNECTION OF SN75365 DEVICES WITH TMS4062-TYPE P-CHANNEL MOS RAM

7

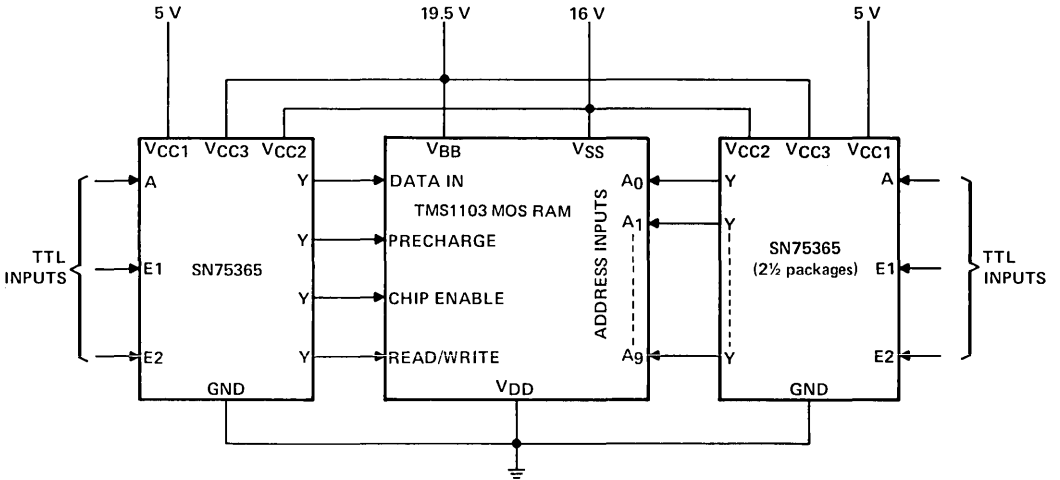

FIGURE 14—INTERCONNECTION OF SN75365 DEVICES WITH TMS1103-TYPE SILICON-GATE MOS RAM

# TYPE SN75365 QUADRUPLE NAND TTL-TO-MOS DRIVER

## TYPICAL APPLICATION DATA

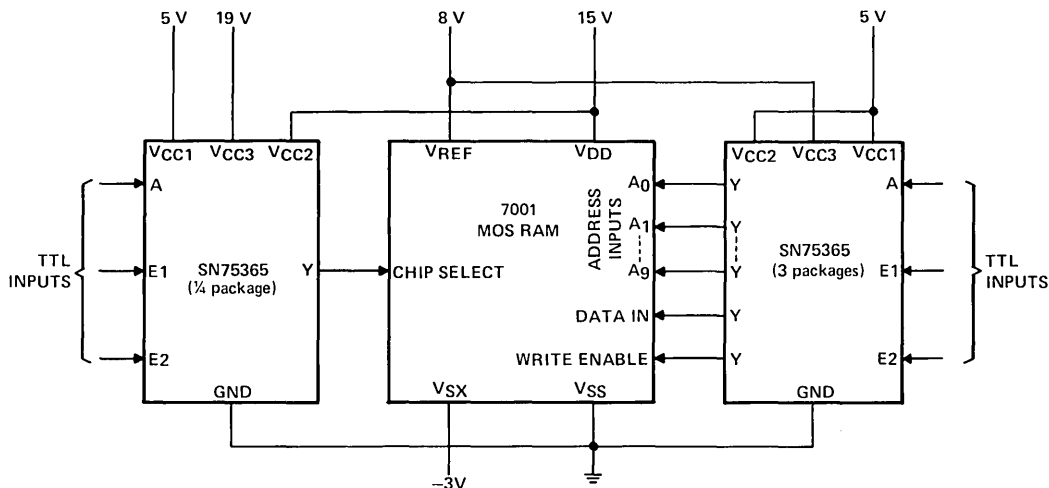

FIGURE 15—INTERCONNECTION OF SN75365 DEVICES WITH 7001-TYPE N-CHANNEL MOS RAM

7

Applications using SN75365 as interface devices between TTL inputs and the address, control, and timing inputs for three types of MOS RAMs are shown in Figures 13, 14, and 15. The VCC3 supply pin of the SN75365 may be connected to the VCC2 pin as shown in Figure 13 or connected to a separate voltage higher than VCC2 as shown in Figures 14 and 15.

Figures 13, 14, and 15 show the use of the SN75365 over a wide range of VCC2 and VCC3 supply voltages. The device may even be used as a TTL gate, if desired, by connecting VCC2 and VCC3 to 5 volts.

The fast switching speeds of this device may produce undesirable output transient overshoot because of load or wiring inductance. A small series damping resistor may be used to reduce or eliminate this output transient overshoot. The optimum value of the damping resistor depends on the specific load characteristics and switching speed. A typical value would be between 10  $\Omega$  and 30  $\Omega$ . See Figure 16.

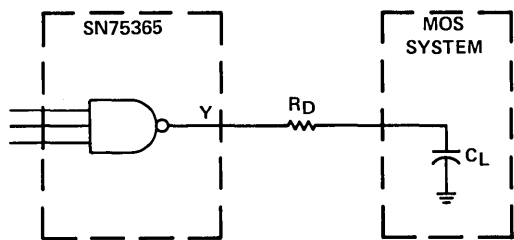

NOTE:  $R_D \approx 10 \Omega$  TO  $30 \Omega$  (optional).

FIGURE 16—USE OF DAMPING RESISTOR TO REDUCE OR ELIMINATE OUTPUT TRANSIENT OVERSHOOT IN CERTAIN SN75365 APPLICATIONS

# TYPE SN75365

## QUADRUPLE NAND TTL-TO-MOS DRIVER

### THERMAL INFORMATION

#### power dissipation precautions

Significant power may be dissipated in the SN75365 driver when charging and discharging high capacitance loads over a wide voltage range at high-frequencies. Figure 6 shows the power dissipated in a typical SN75365 as a function of frequency and load capacitance. Average power dissipated by this driver can be broken into three components:

$$P_T(AV) = P_{DC}(AV) + P_C(AV) + P_S(AV)$$

where  $P_{DC}(AV)$  is the steady-state power dissipation with the output high or low,  $P_C(AV)$  is the power level during charging or discharging of the load capacitance, and  $P_S(AV)$  is the power dissipation during switching between the low and high levels. None of these include energy transferred to the load and all are averaged over a full cycle.

The power components per driver channel are:

$$P_{DC}(AV) = \frac{P_L t_L + P_H t_H}{T}$$

$$P_C(AV) \approx C V_C^2 f$$

$$P_S(AV) = \frac{P_{LH} t_{LH} + P_{HL} t_{HL}}{T}$$

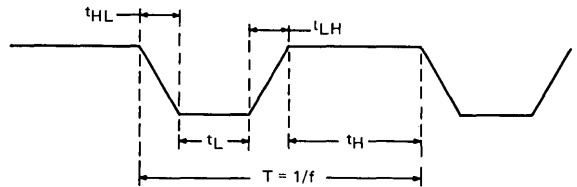

FIGURE 17—OUTPUT VOLTAGE WAVEFORM

where the times are as defined in Figure 17.

$P_L$ ,  $P_H$ ,  $P_{LH}$ , and  $P_{HL}$  are the respective instantaneous levels of power dissipation and  $C$  is load capacitance.

The SN75365 is so designed that  $P_S$  is a negligible portion of  $P_T$  in most applications. Except at very high frequencies,  $t_L + t_H \gg t_{LH} + t_{HL}$  so that  $P_S$  can be neglected. Figure 6 for no load demonstrates this point. The power dissipation contributions from all four channels are then added together to obtain total device power.

7

The following example illustrates this power calculation technique. Assume all four channels are operating identically with  $C = 100$  pF,  $f = 2$  MHz,  $V_{CC1} = 5$  V,  $V_{CC2} = 20$  V,  $V_{CC3} = 24$  V and duty cycle = 60% outputs high ( $t_H/T = 0.6$ ). Also, assume  $V_{OH} = 20$  V,  $V_{OL} = 0.1$  V,  $P_S$  is negligible, and that the current from  $V_{CC2}$  is negligible when the output is low.

On a per-channel basis using data sheet values:

$$P_{DC}(AV) = \left[ (5 \text{ V}) \left( \frac{4 \text{ mA}}{4} \right) + (20 \text{ V}) \left( \frac{-2.2 \text{ mA}}{4} \right) + (24 \text{ V}) \left( \frac{2.2 \text{ mA}}{4} \right) \right] (0.6) +$$

$$\left[ (5 \text{ V}) \left( \frac{31 \text{ mA}}{4} \right) + (20 \text{ V}) \left( \frac{0 \text{ mA}}{4} \right) + (24 \text{ V}) \left( \frac{16 \text{ mA}}{4} \right) \right] (0.4)$$

$$P_{DC}(AV) = 58 \text{ mW per channel}$$

$$P_C(AV) \approx (100 \text{ pF}) (19.9 \text{ V})^2 (2 \text{ MHz})$$

$$P_C(AV) \approx 79 \text{ mW per channel.}$$

For the total device dissipation of the four channels:

$$P_T(AV) \approx 4 (58 + 79)$$

$$P_T(AV) \approx 548 \text{ mW typical for total package.}$$

# INTERFACE CIRCUITS

# TYPE SN75366 QUADRUPLE NAND TTL-TO-MOS DRIVER

BULLETIN NO. DL-S 7712159, APRIL 1975—REVISED APRIL 1977

## MOS MEMORY INTERFACE

- Quad Positive-Logic NAND TTL-to-MOS Driver
- Versatile Interface Circuit for Use between TTL and High-Current, High-Voltage Systems
- Capable of Driving High-Capacitance Loads
- Compatible with Many Popular MOS RAMs
- Equivalent to SN75365 with Internal Output Damping Resistors
- No External Damping Resistors Needed in Most Applications
- Designed to be Interchangeable with Intel 3207
- VCC2 Supply Voltage Variable over Wide Range to 24 Volts Maximum
- VCC3 Supply Voltage Pin Available
- VCC3 Pin Can Be Connected to VCC2 Pin in Some Applications
- TTL and DTL Compatible Diode-Clamped Inputs
- Operates from Standard Bipolar and MOS Supply Voltages
- Two Common Enable Inputs per Gate-Pair
- High-Speed Switching
- Transient Overdrive Minimizes Power Dissipation
- Low Standby Power Dissipation

### description

The SN75366 is a monolithic integrated quadruple TTL-to-MOS driver and interface circuit. The device accepts standard TTL and DTL input signals and provides high-current and high-voltage output levels suitable for driving MOS circuits. Specifically, it may be used to drive address, control, and timing inputs for several types of MOS RAMs including the TMS1103 and TMS4062.

The SN75366 operates from the TTL 5-volt supply and the MOS  $V_{SS}$  and  $V_{BB}$  supplies in many applications. This device has been optimized for operation with  $V_{CC2}$  supply voltage from 16 volts to 20 volts, and with nominal  $V_{CC3}$  supply voltage from 3 volts to 4 volts higher than  $V_{CC2}$ . However, it is designed so as to be useable over a much wider range of  $V_{CC2}$  and  $V_{CC3}$ . In some applications the  $V_{CC3}$  power supply can be eliminated by connecting the  $V_{CC3}$  pin to the  $V_{CC2}$  pin.

The SN75366 is characterized for operation from 0°C to 70°C.

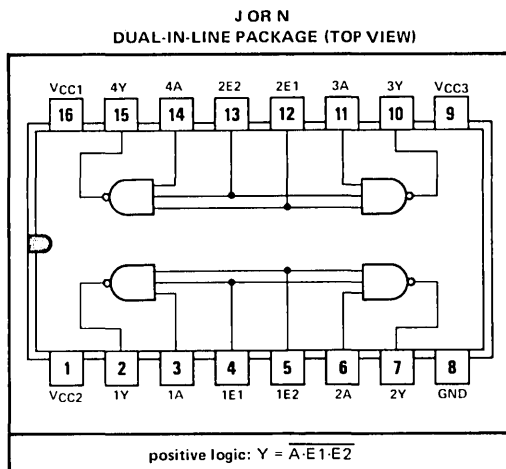

### schematic (each driver)

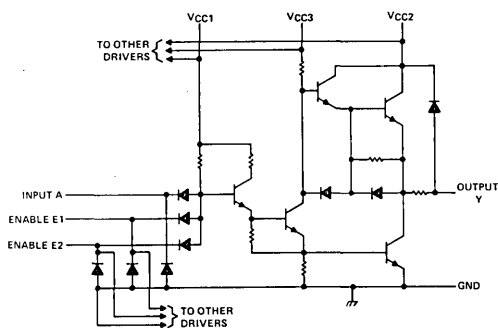

7

# TYPE SN75366

## QUADRUPLE NAND TTL-TO-MOS DRIVER

### absolute maximum ratings over operating free-air temperature range (unless otherwise noted)

Supply voltage range of VCC1 (see Note 1)	-0.5 V to 7 V
Supply voltage range of VCC2	-0.5 V to 25 V
Supply voltage range of VCC3	-0.5 V to 30 V
Input voltage	5.5 V
Inter-input voltage (see Note 2)	5.5 V
Continuous total dissipation at (or below) 25°C free-air temperature (see Note 3):	J package 1025 mW
	N package 1150 mW
Operating free-air temperature range	0°C to 70°C
Storage temperature range	-65°C to 150°C
Lead temperature 1/16 inch from case for 60 seconds: J package	300°C
Lead temperature 1/16 inch from case for 10 seconds: N package	260°C

- NOTES: 1. Voltage values are with respect to network ground terminal unless otherwise noted.  
 2. This rating applies between any two inputs of any one of the drivers.  
 3. For operation above 25°C free-air temperature, refer to Dissipation Derating Curves in the Thermal Information section, which starts on page 2-1. In the J package, SN75366 chips are glass-mounted.

### recommended operating conditions

	MIN	NOM	MAX	UNIT
Supply voltage, VCC1	4.75	5	5.25	V
Supply voltage, VCC2	4.75	20	24	V
Supply voltage, VCC3	VCC2	24	28	V
Voltage difference between supply voltages: VCC3-VCC2	0	4	10	V
Operating free-air temperature, T <sub>A</sub>	0		70	°C



# TYPE SN75366

## QUADRUPLE NAND TTL-TO-MOS DRIVER

electrical characteristics over recommended ranges of  $V_{CC1}$ ,  $V_{CC2}$ ,  $V_{CC3}$  and operating free-air temperature (unless otherwise noted)

PARAMETER	TEST CONDITIONS	MIN	TYP†	MAX	UNIT
$V_{IH}$	High-level input voltage	2			V
$V_{IL}$	Low-level input voltage			0.8	V
$V_{IK}$	Input clamp voltage	$I_I = -12$ mA		-1.5	V
$V_{OH}$	High-level output voltage	$V_{CC3} = V_{CC2} + 3$ V, $V_{IL} = 0.8$ V, $I_{OH} = -100$ $\mu$ A		$V_{CC2} - 0.3$	$V_{CC2} - 0.1$
		$V_{CC3} = V_{CC2} + 3$ V, $V_{IL} = 0.8$ V, $I_{OH} = -10$ mA		$V_{CC2} - 1.7$	$V_{CC2} - 1.2$
		$V_{CC3} = V_{CC2}$ , $V_{IL} = 0.8$ V, $I_{OH} = -50$ $\mu$ A		$V_{CC2} - 1$	$V_{CC2} - 0.7$
		$V_{CC3} = V_{CC2}$ , $V_{IL} = 0.8$ V, $I_{OH} = -10$ mA		$V_{CC2} - 2.8$	$V_{CC2} - 2.1$
$V_{OL}$	Low-level output voltage	$V_{IH} = 2$ V, $I_{OL} = 1$ mA		0.15	0.3
		$V_{CC3} = 10$ V to 28 V, $V_{IH} = 2$ V, $I_{OL} = 30$ mA		1.2	1.9
$V_{OK}$	Output clamp voltage	$V_I = 0$ V, $I_{OH} = 20$ mA		$V_{CC2} + 1.5$	
$I_I$	Input current at maximum input voltage	$V_I = 5.5$ V		1	mA
$I_{IH}$	High-level input current	$V_I = 2.4$ V		A inputs	
				E1 and E2 inputs	
$I_{IL}$	Low-level input current	$V_I = 0.4$ V		A inputs	
				E1 and E2 inputs	
$I_{CC1(H)}$	Supply current from $V_{CC1}$ , all outputs high	$V_{CC1} = 5.25$ V, $V_{CC2} = 24$ V, $V_{CC3} = 28$ V, All inputs at 0 V, No load		4	8
$I_{CC2(H)}$	Supply current from $V_{CC2}$ , all outputs high			-2.2	+0.25 -3.2
$I_{CC3(H)}$	Supply current from $V_{CC3}$ , all outputs high			2.2	3.5
$I_{CC1(L)}$	Supply current from $V_{CC1}$ , all outputs low	$V_{CC1} = 5.25$ V, $V_{CC2} = 24$ V, $V_{CC3} = 28$ V, All inputs at 5 V, No load		31	47
				A inputs	
				E1 and E2 inputs	
$I_{CC2(L)}$	Supply current from $V_{CC2}$ , all outputs low	$V_{CC1} = 5.25$ V, $V_{CC2} = 24$ V, $V_{CC3} = 24$ V, All inputs at 0 V, No load		0.9	2
				A inputs	
				E1 and E2 inputs	
$I_{CC3(L)}$	Supply current from $V_{CC3}$ , all outputs low	$V_{CC1} = 5.25$ V, $V_{CC2} = 24$ V, $V_{CC3} = 24$ V, All inputs at 0 V, No load		16	27
				A inputs	
				E1 and E2 inputs	
$I_{CC2(H)}$	Supply current from $V_{CC2}$ , all outputs high	$V_{CC1} = 5.25$ V, $V_{CC2} = 24$ V, $V_{CC3} = 24$ V, All inputs at 0 V, No load		0.25	
				E1 and E2 inputs	
$I_{CC3(H)}$	Supply current from $V_{CC3}$ , all outputs high	$V_{CC1} = 5.25$ V, $V_{CC2} = 24$ V, $V_{CC3} = 24$ V, All inputs at 0 V, No load		0.5	
				E1 and E2 inputs	
$I_{CC2(S)}$	Supply current from $V_{CC2}$ , standby condition	$V_{CC1} = 0$ V, $V_{CC2} = 24$ V, $V_{CC3} = 24$ V, All inputs at 5 V, No load		0.25	
				E1 and E2 inputs	
$I_{CC3(S)}$	Supply current from $V_{CC3}$ , standby condition	$V_{CC1} = 0$ V, $V_{CC2} = 24$ V, $V_{CC3} = 24$ V, All inputs at 5 V, No load		0.5	
				E1 and E2 inputs	

† All typical values are at  $V_{CC1} = 5$  V,  $V_{CC2} = 20$  V,  $V_{CC3} = 24$  V (unless otherwise noted), and  $T_A = 25^\circ$  C.

switching characteristics,  $V_{CC1} = 5$  V,  $V_{CC2} = 20$  V,  $V_{CC3} = 24$  V,  $T_A = 25^\circ$  C

PARAMETER	TEST CONDITIONS	MIN	TYP	MAX	UNIT
$t_{DLH}$	Delay time, low-to-high-level output			15	22
$t_{DHL}$	Delay time, high-to-low-level output			14	21
$t_{TLH}$	Transition time, low-to-high-level output	$C_L = 200$ pF, See Figure 1		5	18
$t_{THL}$	Transition time, high-to-low-level output			5	18
$t_{PLH}$	Propagation delay time, low-to-high-level output			10	33
$t_{PHL}$	Propagation delay time, high-to-low-level output			10	32

# TYPE SN75366 QUADRUPLE NAND TTL-TO-MOS DRIVER

## PARAMETER MEASUREMENT INFORMATION

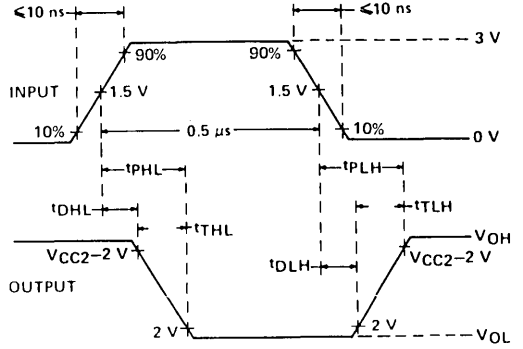
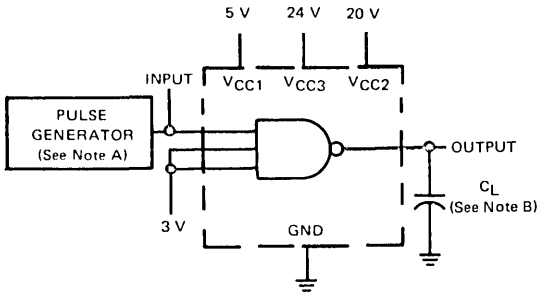

NOTES: A. The pulse generator has the following characteristics: PRR = 1 MHz,  $Z_{out} \approx 50 \Omega$ .  
B.  $C_L$  includes probe and jig capacitance.

FIGURE 1—SWITCHING TIMES, EACH DRIVER

## TYPICAL CHARACTERISTICS

TOTAL DISSIPATION  
(ALL DRIVERS)  
vs  
FREQUENCY

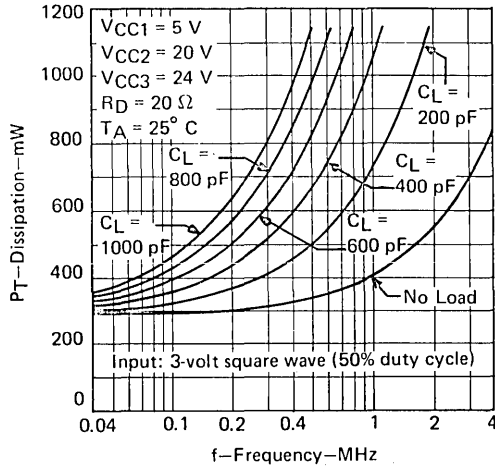

FIGURE 2



# TYPE SN75366 QUADRUPLE NAND TTL-TO-MOS DRIVER

## TYPICAL APPLICATION DATA

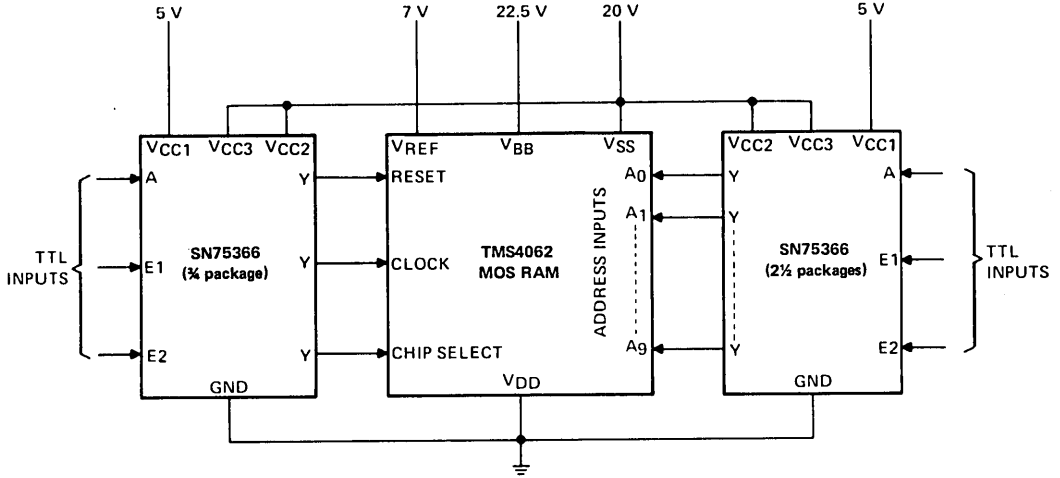

FIGURE 3—INTERCONNECTION OF SN75366 DEVICES WITH TMS4062-TYPE P-CHANNEL MOS RAM

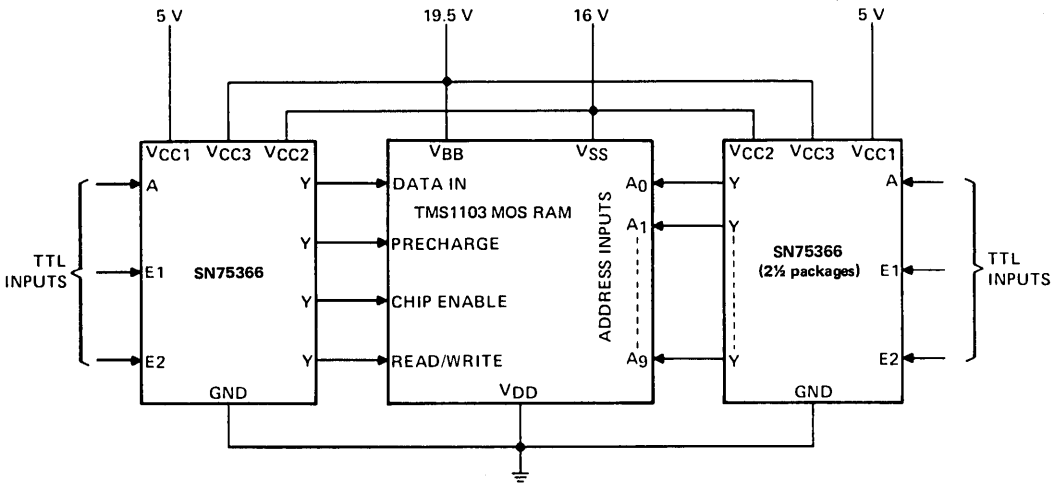

FIGURE 4—INTERCONNECTION OF SN75366 DEVICES WITH TMS1103-TYPE SILICON-GATE MOS RAM

# TYPE SN75366 QUADRUPLE NAND TTL-TO-MOS DRIVER

## TYPICAL APPLICATION DATA

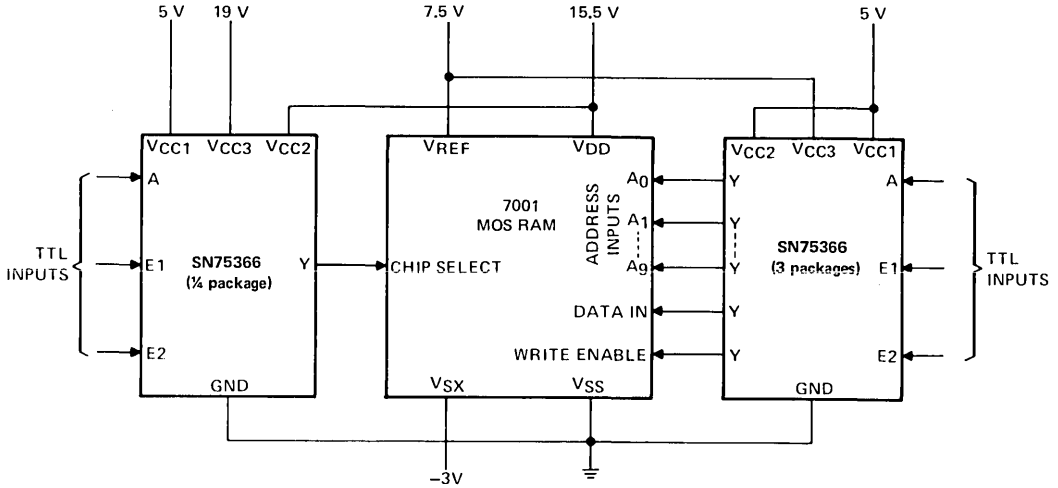
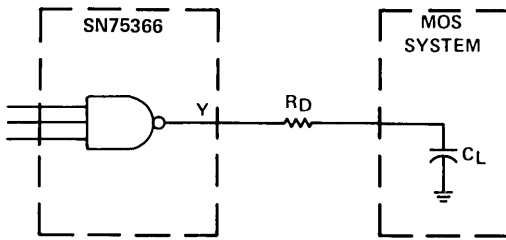

FIGURE 5—INTERCONNECTION OF SN75366 DEVICES WITH 7001-TYPE N-CHANNEL MOS RAM

7

Applications using SN75366 as interface devices between TTL inputs and the address, control, and timing inputs for three types of MOS RAMs are shown in Figure 3, 4, and 5. The  $V_{CC3}$  supply pin of the SN75366 may be connected to the  $V_{CC2}$  pin as shown in Figure 3 or connected to a separate voltage higher than  $V_{CC2}$  as shown in Figures 4 and 5.



NOTE:  $R_D \approx 5$  to  $20 \Omega$  (optional).

FIGURE 6—USE OF DAMPING RESISTOR TO REDUCE OR ELIMINATE OUTPUT TRANSIENT OVERSHOOT IN CERTAIN SN75366 APPLICATIONS

Figures 3, 4, and 5 show the use of the SN75366 over a wide range of  $V_{CC2}$  and  $V_{CC3}$  supply voltages. The device may even be used as a TTL gate, if desired, by connecting  $V_{CC2}$  and  $V_{CC3}$  to 5 volts.

The fast switching speeds of many MOS drivers produce undesirable output transient overshoot because of load or wiring inductance. Often a small external series damping resistor is used to reduce or eliminate this output transient overshoot. The optimum value of the damping resistor depends on the specific load characteristics and switching speed.

In most applications the internal damping resistor in the SN75366 eliminates the need for an external damping resistor. However, an external damping resistor may still be desired in some applications. See Figure 6.

# INTERFACE CIRCUITS

# TYPE SN75367 QUADRUPLE TTL-TO-MOS DRIVER WITH 3-STATE OUTPUTS

BULLETIN NO. DL-S 7712374, MAY 1976—REVISED APRIL 1977

- Quad Inverting TTL-to-MOS Drivers
- Three-State Outputs
- Versatile Interface Circuit for Use Between TTL and High-Current, High-Voltage Systems
- CMOS Applications
- High-Speed Switching
- TTL- and DTL-Compatible Inputs
- Separate Address and Enable/Disable Inputs for Each Driver
- $V_{CC2}$  Variable Over Wide Range . . .  $V_{CC1}$  to 15 V

### description

The SN75367 is a monolithic quadruple TTL-to-MOS driver and interface circuit with three-state outputs. Each driver output may be disabled to the high-impedance state by taking the C input high to allow multiple drivers to be connected to the same bus line for selective enable operation. The SN75367 is designed such that the output disable times are shorter than the output enable times to minimize the possibility that two outputs will attempt to take a common bus line to opposite logic levels. The SN75367 is characterized for operation from 0°C to 70°C.

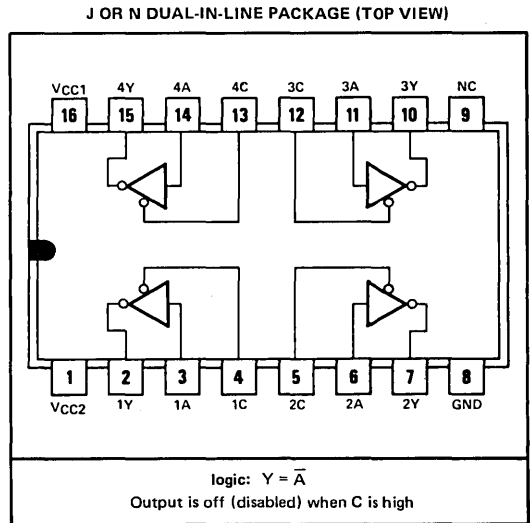

NC—No internal connection

### schematics of inputs and outputs

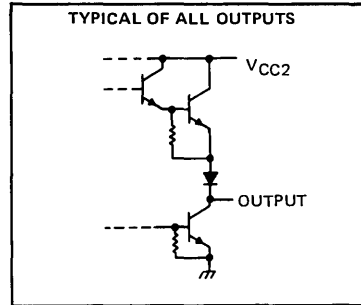
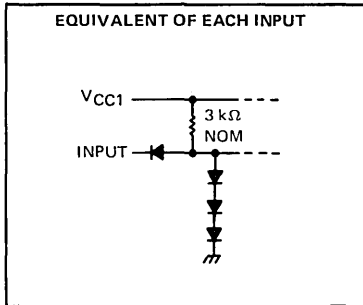

### absolute maximum ratings over operating free-air temperature range (unless otherwise noted)

Supply voltage range of $V_{CC1}$ (see Note 1)	−0.5 V to 7 V
Supply voltage range of $V_{CC2}$	−0.5 V to 16 V
Input voltage	5.5 V
Continuous total dissipation at (or below) 25°C free-air temperature (see Note 2): J package	1025 mW
N package	1150 mW
Operating free-air temperature range	0°C to 70°C
Storage temperature range	−65°C to 150°C
Lead temperature 1/16 inch from case for 60 seconds: J package	300°C
Lead temperature 1/16 inch from case for 10 seconds: N package	260°C

- NOTES: 1. Voltage values are with respect to network ground terminal unless otherwise noted.  
2. For operation above 25°C free-air temperature, refer to Dissipation Derating Curves in the Thermal Information section, which starts on page 2-1. In the J package, SN75367 chips are glass-mounted.

TEXAS INSTRUMENTS  
INCORPORATED

POST OFFICE BOX 225012 • DALLAS, TEXAS 75265

# TYPE SN75367

## QUADRUPLE TTL-TO-MOS DRIVER WITH 3-STATE OUTPUTS

### recommended operating conditions

	MIN	NOM	MAX	UNIT
Supply voltage, $V_{CC1}$	4.75	5	5.25	V
Supply voltage, $V_{CC2}$	4.75	12	15	V
Operating free-air temperature, $T_A$	0		70	°C

### electrical characteristics over recommended ranges of $V_{CC1}$ , $V_{CC2}$ , and operating free-air temperature (unless otherwise noted)

PARAMETER	TEST CONDITIONS	MIN	TYP†	MAX	UNIT	
$V_{IH}$	High-level input voltage	2			V	
$V_{IL}$	Low-level input voltage	0.8			V	
$V_{OH}$	High-level output voltage	$V_{CC1} = 4.75\text{ V}$ , A inputs at 0.8 V,	$V_{CC2} = 10.8\text{ V}$ , C inputs at 0.8 V,	$I_O = -50\text{ }\mu\text{A}$ $I_O = -10\text{ mA}$	$V_{CC2}-1.6$ $V_{CC2}-1.2$ $V_{CC2}-2.7$ $V_{CC2}-2.4$	V
$V_{OL}$	Low-level output voltage	$V_{CC1} = 4.75\text{ V}$ , C inputs = 0.8 V,	$V_{CC2} = 10.8\text{ V}$ , $I_O = 10\text{ mA}$	A inputs at 2 V,	0.3 0.5	V
$I_I$	Input current at maximum input voltage	$V_I = 5.5\text{ V}$			1	mA
$I_{IH}$	High-level input current	$V_I = 2.4\text{ V}$			40	$\mu\text{A}$
$I_{IL}$	Low-level input current	A inputs C inputs	$V_I = 0.4\text{ V}$		-1.5 -2.2	mA
					-1.6	
$I_{OZH}$	Off-state output current, high-level voltage applied	$V_{CC1} = 5\text{ V}$ , A inputs at 0 V,	$V_{CC2} = 12\text{ V}$ , C inputs at 2.4 V,	$V_O = 12\text{ V}$	-250	$\mu\text{A}$
$I_{OZL}$	Off-state output current, low-level voltage applied	$V_{CC1} = 5\text{ V}$ , A inputs at 2.4 V,	$V_{CC2} = 12\text{ V}$ , C inputs at 2.4 V,	$V_O = 0\text{ V}$	250	$\mu\text{A}$
$I_{CC1(H)}$	Supply current from $V_{CC1}$ , all outputs high	$V_{CC1} = 5.25\text{ V}$ , $V_{CC2} = 15\text{ V}$ , All inputs at 0 V, No load			11 16	mA
$I_{CC2(H)}$	Supply current from $V_{CC2}$ , all outputs high				0.6	mA
$I_{CC1(L)}$	Supply current from $V_{CC1}$ , all outputs low	$V_{CC1} = 5.25\text{ V}$ , $V_{CC2} = 15\text{ V}$ , A inputs at 5 V, C inputs at 0 V, No load			17 24	mA
$I_{CC2(L)}$	Supply current from $V_{CC2}$ , all outputs low				24 37	mA
$I_{CC1(Z)}$	Supply current from $V_{CC1}$ , all outputs off	$V_{CC1} = 5.25\text{ V}$ , $V_{CC2} = 15\text{ V}$ , A inputs at 5 V, C inputs at 5 V, No load			23 32	mA
$I_{CC1(Z)}$	Supply current from $V_{CC1}$ , all outputs off	$V_{CC1} = 5.25\text{ V}$ , $V_{CC2} = 15\text{ V}$ , A input at 0 V, C inputs at 5 V, No load			22 32	mA
$I_{CC2(Z)}$	Supply current from $V_{CC2}$ , all outputs off	$V_{CC1} = 5.25\text{ V}$ , $V_{CC2} = 15\text{ V}$ , A inputs at 5 V, C inputs at 5 V, No load			26 39	mA

† All typical values are at  $V_{CC1} = 5\text{ V}$ ,  $V_{CC2} = 12\text{ V}$ , and  $T_A = 25^\circ\text{C}$  except for  $V_{OH}$  for which  $V_{CC1}$  and  $V_{CC2}$  are as stated under test conditions.

### switching characteristics, $V_{CC1} = 5\text{ V}$ , $V_{CC2} = 12\text{ V}$ , $T_A = 25^\circ\text{C}$

PARAMETER	TEST CONDITIONS	MIN	TYP	MAX	UNIT
$t_{PLH}$	Propagation delay time, low-to-high-level output	4	16	26	ns
$t_{PHL}$	Propagation delay time, high-to-low-level output	8	20	32	ns
$t_{TLH}$	Transition time, low-to-high-level output	3	15	23	ns
$t_{THL}$	Transition time, high-to-low-level output	6	21	32	ns
$t_{pZH}$	Output enable time to high level	9	21	31	ns
$t_{pZL}$	Output enable time to low level	10	30	42	ns
$t_{pHZ}$	Output disable time from high level	1	8	15	ns
$t_{pLZ}$	Output disable time from low level	6	15	27	ns

$C_L = 250\text{ pF}$ ,  
See Figures 1 thru 4

# TYPE SN75367 QUADRUPLE TTL-TO-MOS DRIVER WITH 3-STATE OUTPUTS

## PARAMETER MEASUREMENT INFORMATION

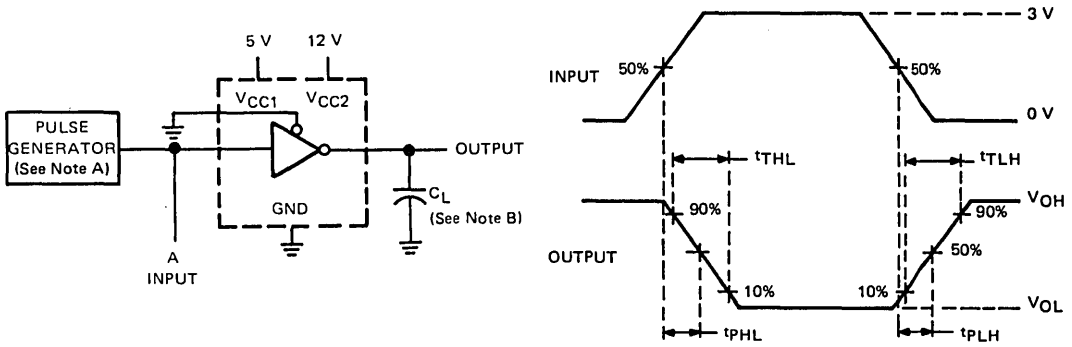

FIGURE 1—TEST CIRCUIT AND VOLTAGE WAVEFORMS FOR  $t_{pLH}$ ,  $t_{pHL}$ ,  $t_{TLH}$ ,  $t_{THL}$

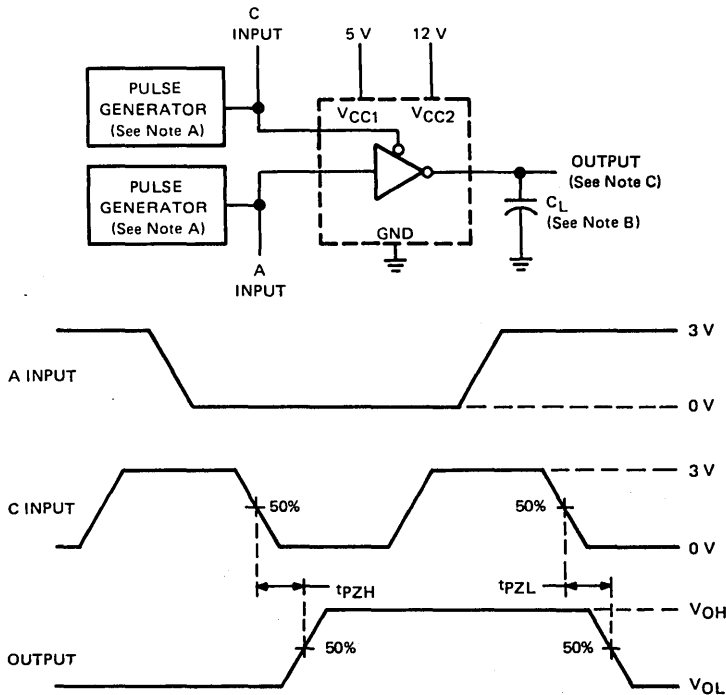

FIGURE 2—TEST CIRCUIT AND VOLTAGE WAVEFORMS FOR  $t_{pZH}$  AND  $t_{pZL}$

- NOTES: A. The pulse generators have the following characteristics: PRR = 1 MHz, (2 MHz for C input in Figure 2),  $Z_{out} = 50 \Omega$ .  
 B.  $C_L$  includes probe and jig capacitance.  
 C. Waveforms are monitored on an oscilloscope with the following characteristics:  $t_r < 5 \text{ ns}$ ,  $R_{in} > 1 \text{ M}\Omega$ .

7

# TYPE SN75367

## QUADRUPLE TTL-TO-MOS DRIVER WITH 3-STATE OUTPUTS

### PARAMETER MEASUREMENT INFORMATION

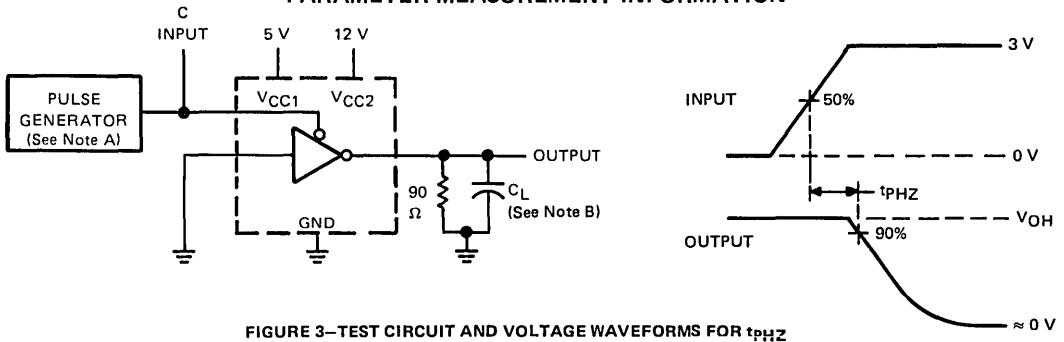

FIGURE 3—TEST CIRCUIT AND VOLTAGE WAVEFORMS FOR  $t_{PHZ}$

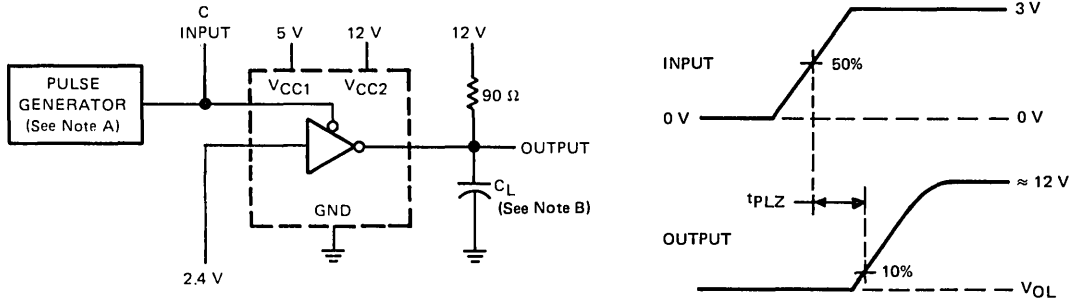

FIGURE 4—TEST CIRCUIT AND VOLTAGE WAVEFORMS FOR  $t_{PLZ}$

NOTES: A. The pulse generator has the following characteristics: PRR = 1 MHz,  $Z_{out} = 50\ \Omega$ .  
 B.  $C_L$  includes probe and jig capacitance.

### TYPICAL CHARACTERISTICS

#### TOTAL DISSIPATION (ALL DRIVERS)

vs  
 FREQUENCY

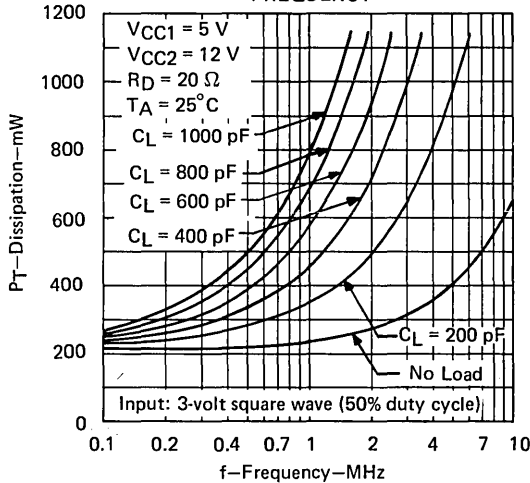
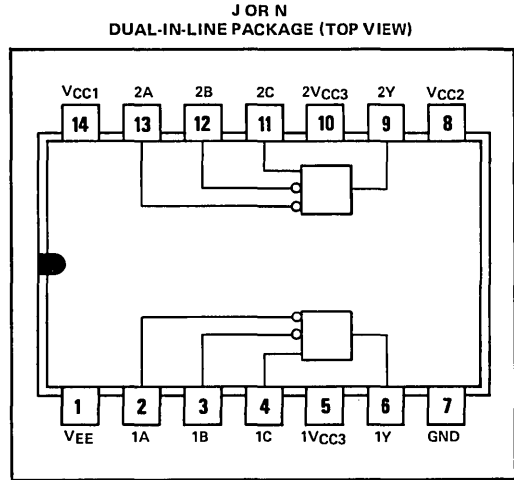

FIGURE 5

## MOS MEMORY INTERFACE

- Dual ECL-to-MOS Drivers
- Dual ECL-to-TTL Drivers
- Versatile Interface Circuits for Use Between ECL and High-Current, High-Voltage Systems
- Capable of Driving High-Capacitance Loads
- Compatible with Many Popular MOS RAMs
- Inputs are Compatible with Series 10000 ECL and Other Similar ECL Families
- Single In-Phase and Dual Out-of-Phase Inputs per Driver
- Operates from Standard Bipolar and MOS Supply Voltages
- $V_{CC2}$  Supply Voltage Variable over Wide Range . . . 4.75 V to 22 V
- Two Independent  $V_{CC3}$  Supply Voltage Pins Available
- $V_{CC3}$  Pins Can Be Connected to  $V_{CC2}$  Pin in Some Applications
- High-Speed Switching
- Transient Overdrive Minimizes Power Dissipation



FUNCTION TABLE

	INPUTS			OUTPUT Y
	DIFFERENTIAL (More positive of A or B) - C	LOGIC LEVEL		
	A	B	C	
H ( $V_{ID} > 150$ mV)	L	H	L	L
	H	H	L	
? ( $-150$ mV $\leq V_{ID} \leq 150$ mV)	X	X	X	INDETERMINATE
L ( $V_{ID} \leq -150$ mV)	L	L	H	H

H = high level, L = low level, X = irrelevant  
See additional function tables in Figure 6.

### description

The SN75368 is a monolithic dual ECL-to-MOS driver and interface circuit. The device accepts standard input signals from Series SN10000 ECL and other similar ECL families and provides high-current and high-voltage output levels suitable for driving MOS and TTL circuits. Specifically, it may be used to drive address, control, and timing inputs for several types of MOS RAMs including the TMS1103, TMS1103-1, TMS4030, TMS4062, and 7001.

The SN75368 operates from the TTL  $V_{CC}$  supply, the ECL  $V_{EE}$  supply, and standard MOS supplies in most applications. This device has been optimized for operation with a  $V_{CC2}$  supply voltage from 12 volts to 20 volts with nominal  $V_{CC3}$  supply voltages from 3 to 4 volts higher than  $V_{CC2}$ . However, the SN75368 was designed so as to be useable over a much wider range of  $V_{CC2}$  and  $V_{CC3}$ . In some applications the  $V_{CC3}$  power supply can be eliminated by connecting the two  $V_{CC3}$  pins to the  $V_{CC2}$  pin. By connecting the  $V_{CC2}$  pin to the TTL 5-volt supply, the device can be used as an ECL-to-TTL converter.

The device has one in-phase and two out-of-phase ECL-compatible inputs per driver. By proper connections of the inputs, the SN75368 may be used three ways: positive-NOR gate, differential ECL line receiver, or noninverting gate. Some applications require one input per gate to be connected to an externally generated ECL reference voltage,  $V_{BB}$ .

The SN75368 is characterized for operation from  $0^{\circ}\text{C}$  to  $70^{\circ}\text{C}$ .

# TYPE SN75368 DUAL ECL-TO-MOS DRIVER

## schematics of inputs and outputs

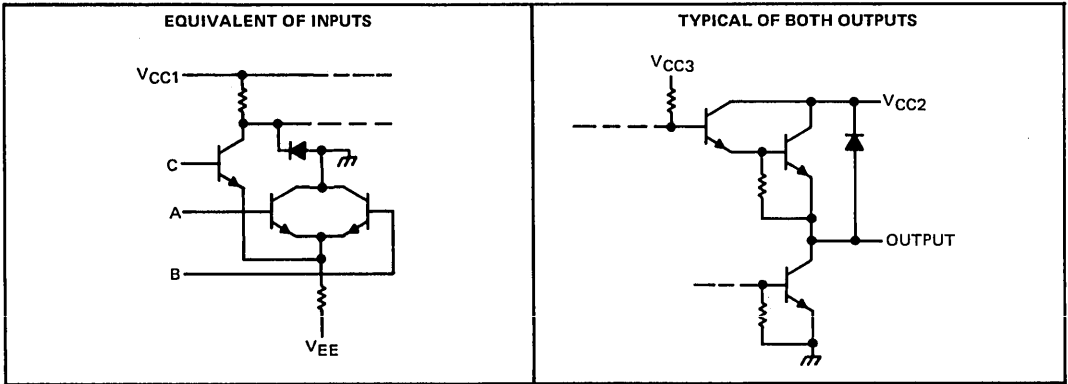

### absolute maximum ratings over operating free-air temperature range (unless otherwise noted)

Supply voltage range of VCC1 (see Note 1)	-.0.5 to 7 V
Supply voltage range of VCC2	-.0.5 to 22 V
Supply voltage range of 1VCC3 and 2VCC3	-.0.5 to 30 V
Supply voltage range of VEE	-.8 to 0.5 V
Negative voltage at VCC1, VCC2, 1VCC3, or 2VCC3 with respect to VEE	-.0.5 V
Input voltage range	-.7V to 0.5 V
Negative voltage at any input with respect to VEE	-.1 V
Differential input voltage	5.5 V
Continuous total dissipation at (or below) 25°C free-air temperature (see Note 2):	
J package	1025 mW
N package	1150 mW
Operating free-air temperature range	0°C to 70°C
Storage temperature range	-.65° to 150°C
Lead temperature 1/16 inch from case for 60 seconds: J package	300°C
Lead temperature 1/16 inch from case for 10 seconds: N package	260°C

NOTES: 1. Voltage values are with respect to network ground terminal unless otherwise noted.  
2. For operation above 25°C free-air temperature, refer to Dissipation Derating Curves in the Thermal Information section, which starts on page 2-1. In the J package, SN75368 chips are glass-mounted.

### recommended operating conditions

	MIN	NOM	MAX	UNIT
Supply voltage, VCC1	4.75	5	5.25	V
Supply voltage, VCC2	4.75	20	22	V
Supply voltage, 1VCC3 and 2VCC3	VCC2	24	28	V
Voltage difference between supply voltages: 1VCC3-VCC2 and 2VCC3-VCC2	0	4	10	V
Supply voltage, VEE	-4.68	-5.2	-5.72	V
Operating free-air temperature, TA	0		70	°C

### definition of input logic levels (see Note 3)

PARAMETER	B	A	UNIT
	(Least Positive)	(Most Positive)	
V <sub>IH</sub> High-level input voltage at any input	-1.5	-0.7	V
V <sub>IL</sub> Low-level input voltage at any input	VEE	V <sub>IH</sub> -150 mV	
V <sub>IDH</sub> High-level differential input voltage (see Note 3)	150		mV
V <sub>IDL</sub> Low-level differential input voltage (see Note 3)		-150	mV

NOTE 3: Differential input voltage is the voltage at the more-positive inverting input (A or B) with respect to the noninverting input (C) of the same gate.



# TYPE SN75368

## DUAL ECL-TO-MOS DRIVER

electrical characteristics over recommended ranges of  $V_{CC1}$ ,  $V_{CC2}$ ,  $V_{CC3}$ ,  $V_{EE}$ , and operating free-air temperature (unless otherwise noted)

PARAMETER		TEST CONDITIONS	MIN	TYP <sup>†</sup>	MAX	UNIT		
$V_{OH}$	High-level output voltage	$V_{CC3} = V_{CC2} + 3\text{ V}$ , $V_{IDL} = -150\text{ mV}$ , $I_{OH} = -100\text{ }\mu\text{A}$	$V_{CC2} - 0.3$		$V_{CC2} - 0.1$	V		
		$V_{CC3} = V_{CC2} + 3\text{ V}$ , $V_{IDL} = -150\text{ mV}$ , $I_{OH} = -10\text{ mA}$	$V_{CC2} - 1.2$		$V_{CC2} - 0.9$			
		$V_{CC3} = V_{CC2}$ , $V_{IDL} = -150\text{ mV}$ , $I_{OH} = -50\text{ }\mu\text{A}$	$V_{CC2} - 1$		$V_{CC2} - 0.7$			
		$V_{CC3} = V_{CC2}$ , $V_{IDL} = -150\text{ mV}$ , $I_{OH} = -10\text{ mA}$	$V_{CC2} - 2.3$		$V_{CC2} - 1.8$			
$V_{OL}$	Low-level output voltage	$V_{IDH} = 150\text{ mV}$ , $I_{OL} = 10\text{ mA}$			0.15	V		
		$V_{CC3} = 10\text{ V to } 28\text{ V}$ , $V_{IDH} = 150\text{ mV}$ , $I_{OL} = 30\text{ mA}$			0.2			
$V_{OK}$	Output clamp voltage	$V_{ID} = -500\text{ mV}$ , $I_{OH} = 20\text{ mA}$			$V_{CC2} + 1.5$	V		
$I_{IH}$	High-level input current	$V_{EE} = -5.72\text{ V}$ , $V_I = -0.7\text{ V}$ All other inputs at $-5.72\text{ V}$			300	800	$\mu\text{A}$	
$I_{IL}$	Low-level input current	$V_I = -2\text{ V}$ , All other inputs at $-0.7\text{ V}$				-10	$\mu\text{A}$	
		$V_{EE} = -5.72\text{ V}$ , $V_I = -5.72\text{ V}$ , All other inputs at $-0.7\text{ V}$				-100		
$I_{CC1(H)}$	Supply current from $V_{CC1}$ , all outputs high	$V_{CC1} = 5.25\text{ V}$ , $V_{CC2} = 22\text{ V}$ , $V_{CC3} = 28\text{ V}$ , $V_{EE} = -5.72\text{ V}$ , All A and B inputs at $-2\text{ V}$ , Both C inputs at $-0.7\text{ V}$ , No load			21	38	mA	
$I_{CC2(H)}$	Supply current from $V_{CC2}$ , all outputs high				-2	+0.25		
$I_{CC3(H)}$	Supply current from $1V_{CC3}$ or $2V_{CC3}$ , all outputs high				1	1.8		
$I_{EE(H)}$	Supply current from $V_{EE}$ , all outputs high				-21	-38		
$I_{CC1(L)}$	Supply current from $V_{CC1}$ , all outputs low	$V_{CC1} = 5.25\text{ V}$ , $V_{CC2} = 22\text{ V}$ , $V_{CC3} = 28\text{ V}$ , $V_{EE} = -5.72\text{ V}$ , All A and B inputs at $-0.7\text{ V}$ , Both C inputs at $-2\text{ V}$ , No load			13	24	mA	
$I_{CC2(L)}$	Supply current from $V_{CC2}$ , all outputs low				0.5	1		
$I_{CC3(L)}$	Supply current from $1V_{CC3}$ or $2V_{CC3}$ , all outputs low				4	8		
$I_{EE(L)}$	Supply current from $V_{EE}$ , all outputs low				-21	-38		
$I_{CC2(H)}$	Supply current from $V_{CC2}$ , all outputs high	$V_{CC1} = 5.25\text{ V}$ , $V_{CC2} = 22\text{ V}$ , $V_{CC3} = 22\text{ V}$ , $V_{EE} = -5.72\text{ V}$ , All A and B inputs at $-2\text{ V}$ , Both C inputs at $-0.7\text{ V}$ , No load					0.25	mA
$I_{CC3(H)}$	Supply current from $1V_{CC3}$ or $2V_{CC3}$ , all outputs high						0.25	
$I_{CC2(S)}$	Supply current from $V_{CC2}$ , stand-by condition	$V_{CC1} = 0\text{ V}$ , $V_{CC2} = 22\text{ V}$ , $V_{CC3} = 22\text{ V}$ , $V_{EE} = 0\text{ V}$					0.25	mA
$I_{CC3(S)}$	Supply current from $1V_{CC3}/2V_{CC3}$ , stand-by condition	All A and B inputs at $-0.7\text{ V}$ , Both C inputs at $-2\text{ V}$ , No load					0.25	

<sup>†</sup>All typical values are at  $V_{CC1} = 5\text{ V}$ ,  $V_{CC2} = 20\text{ V}$ ,  $V_{CC3} = 24\text{ V}$ ,  $V_{EE} = -5.2\text{ V}$ , and  $T_A = 25^\circ\text{C}$  except for  $V_{OH}$  for which  $V_{CC1}$  and  $V_{CC2}$  are as stated under test conditions.

switching characteristics,  $V_{CC1} = 5\text{ V}$ ,  $V_{CC2} = 20\text{ V}$ ,  $V_{EE} = -5.2\text{ V}$ ,  $T_A = 25^\circ\text{C}$

PARAMETER	TEST CONDITIONS	$V_{CC3} = 24\text{ V}$			$V_{CC3} = 20\text{ V}$			UNIT
		MIN	TYP	MAX	MIN	TYP	MAX	
$t_{DLH}$	Delay time, low-to-high-level output	4	12	22	5	13	23	ns
$t_{DHL}$	Delay time, high-to-low-level output	5	13	23	5	15	24	ns
$t_{TLH}$	Transition time, low-to-high-level output	7	19	32	8	20	33	ns
$t_{THL}$	Transition time, high-to-low-level output	8	20	33	6	18	33	ns
$t_{PLH}$	Propagation delay time, low-to-high-level output	11	31	54	13	33	56	ns
$t_{PHL}$	Propagation delay time, high-to-low-level output	13	33	56	11	33	57	ns

$C_L = 390\text{ pF}$ ,  
 $R_D = 10\text{ }\Omega$ ,  
See Figure 1

# TYPE SN75368 DUAL ECL-TO-MOS DRIVER

## PARAMETER MEASUREMENT INFORMATION

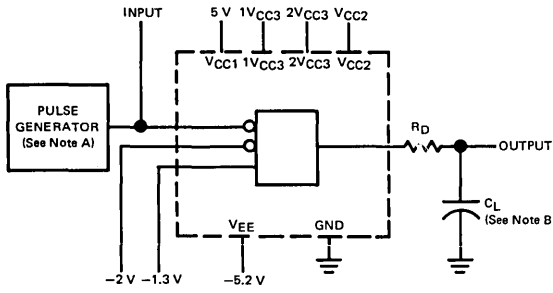

TEST CIRCUIT

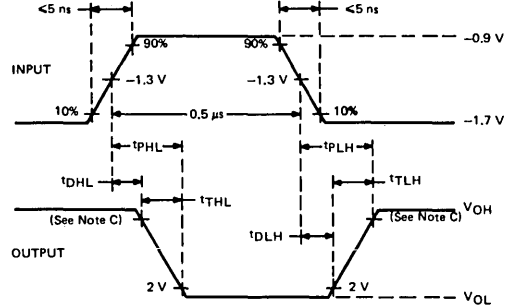

VOLTAGE WAVEFORMS

- NOTES: A. The pulse generator has the following characteristics: PRR = 1 MHz,  $Z_{out} \approx 50 \Omega$ .  
 B.  $C_L$  includes probe and jig capacitance.  
 C. The high-level reference point is 17 V when  $V_{CC3} = V_{CC2} = 20 V$ , and is 18 V when  $V_{CC3} = V_{CC2} + 4 V = 24 V$ .

FIGURE 1—SWITCHING TIMES, EACH DRIVER

## TYPICAL CHARACTERISTICS

TOTAL DISSIPATION  
(BOTH DRIVERS)  
vs  
FREQUENCY

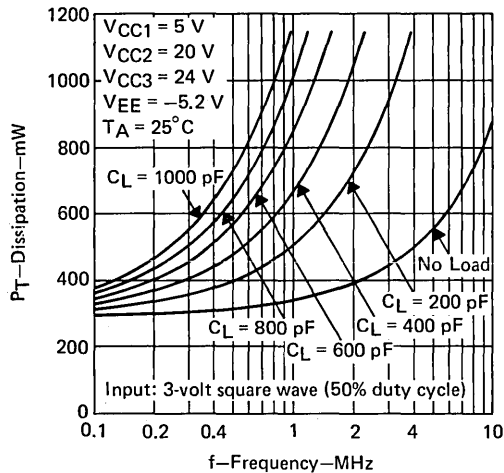

FIGURE 2

# TYPE SN75368 DUAL ECL-TO-MOS DRIVER

## TYPICAL APPLICATION DATA

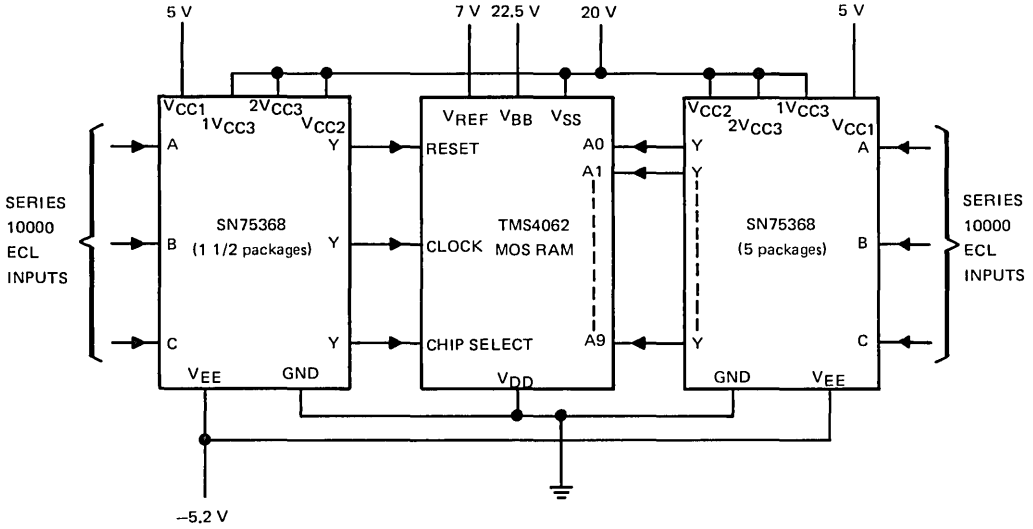

FIGURE 3—INTERCONNECTION OF SN75368 DEVICES WITH TMS4062-TYPE P-CHANNEL MOS RAM

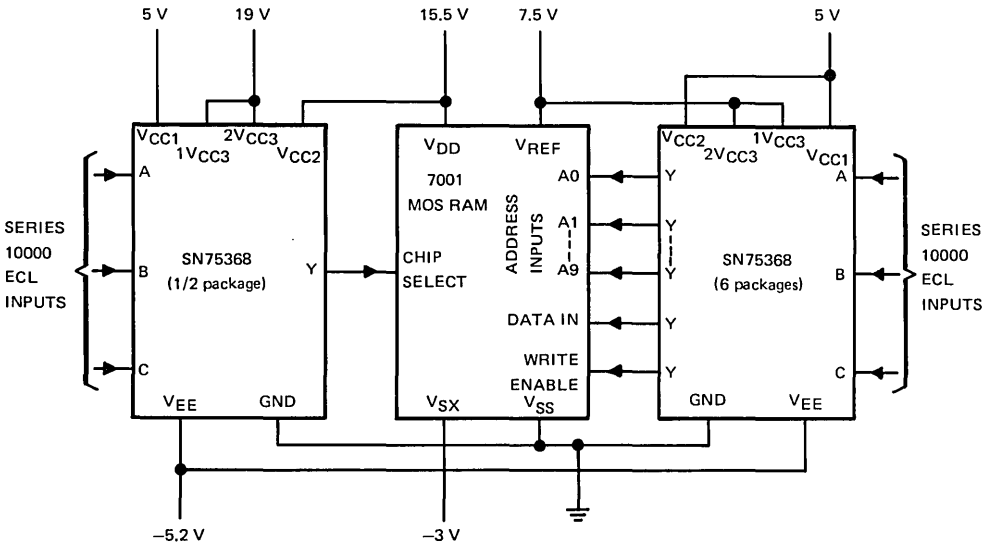

FIGURE 4—INTERCONNECTION OF SN75368 DEVICES WITH 7001-TYPE N-CHANNEL MOS RAM

# TYPE SN75368 DUAL ECL-TO-MOS DRIVER

## TYPICAL APPLICATION DATA

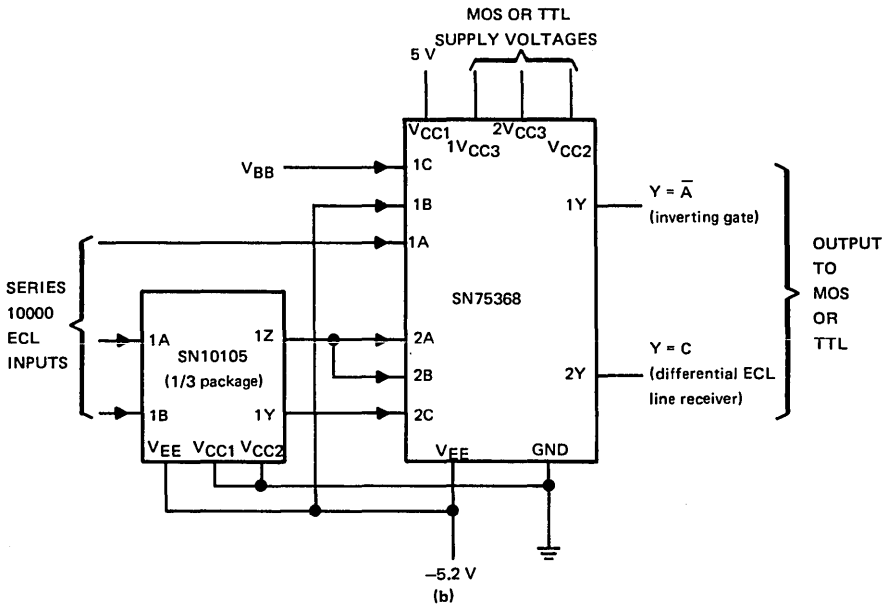
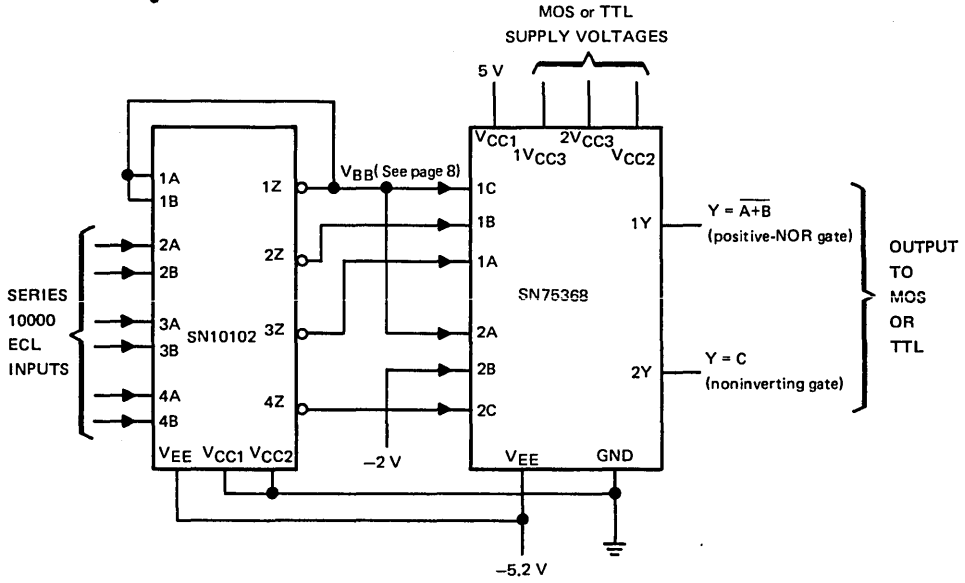
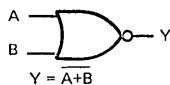

FIGURE 5—REPRESENTATIVE METHODS OF INTERCONNECTING SN75368 DEVICES WITH SN10000 SERIES ECL

# TYPE SN75368 DUAL ECL-TO-MOS DRIVER

## TYPICAL APPLICATION DATA

### positive-NOR gate



FUNCTION TABLE

CONFIGURATION	INPUTS			OUTPUT	
	A	B	C	Y	Y
C at $V_{BB}$	L	L	$V_{BB}$	H	H
	H	X	$V_{BB}$	L	L
	X	H	$V_{BB}$	L	L

### noninverting gate

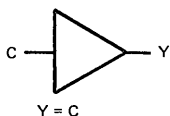

FUNCTION TABLE

CONFIGURATION	INPUTS			OUTPUT	
	A	B	C	Y	Y
A and B at $V_{BB}$	$V_{BB}$	$V_{BB}$	L	L	L
	$V_{BB}$	$V_{BB}$	H	H	H
A at $V_{BB}$ , B connected low	$V_{BB}$	L	L	L	L
B at $V_{BB}$ , A connected low	L	$V_{BB}$	L	L	L
A and B at $V_{BB}$	$V_{BB}$	$V_{BB}$	H	H	H

### differential ECL line receiver

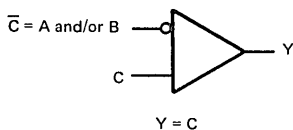

FUNCTION TABLE

CONFIGURATION	INPUTS			OUTPUT	
	A	B	C	Y	Y
A and B connected together	H	H	L	L	L
	L	L	H	H	H
A not used but connected low	L	H	L	L	L
B not used but connected low	L	L	H	H	H

H = high level, L = low level, X = irrelevant  
 $V_{BB}$  = Reference Supply voltage for SN10000 Series ECL.

FIGURE 6—FUNCTIONS

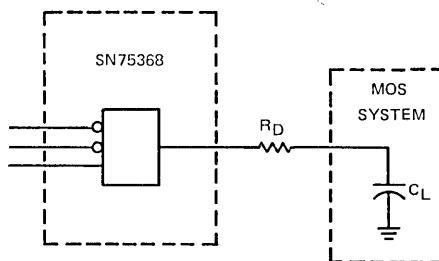

NOTE:  $R_D \approx 10 \Omega$  to  $30 \Omega$  (optional).

FIGURE 7—USE OF DAMPING RESISTOR TO REDUCE OR ELIMINATE OUTPUT TRANSIENT OVERSHOOT IN CERTAIN SN75368 APPLICATIONS

Applications using the SN75368 as an interface device between series SN10000 ECL inputs and the address, control, and timing inputs for two types of MOS RAMS are shown in Figures 3 and 4. The  $1V_{CC3}$  and  $2V_{CC3}$  supply pins of the SN75368 may be connected to the  $V_{CC2}$  pin as shown in Figure 3 or connected to a separate voltage higher than  $V_{CC2}$  as shown in Figure 4. If desired, the  $1V_{CC3}$  pin may be connected to a voltage different from the  $2V_{CC3}$  pin.

Figures 3 and 4 show the use of the SN75368 over a wide range of  $V_{CC2}$ ,  $1V_{CC3}$ , and  $2V_{CC3}$  supply voltages. This device may even be used as ECL-to-TTL-level converters, if desired, by connecting  $V_{CC2}$ ,  $1V_{CC3}$ , and  $2V_{CC3}$  to 5 volts.

The one in-phase (C) and two out-of phase (A and B) inputs per driver permit much flexibility when using the SN75368. By connecting the correct input to an externally generated  $V_{BB}$  (ECL reference supply voltage) positive-NOR gate, inverting gate, or noninverting gate functions may be obtained as shown in Figure 5. By driving the correct inputs differentially as in Figure 5 (b), these devices may be used as differential ECL line receivers and no  $V_{BB}$  reference voltage is required. The  $V_{BB}$  reference voltage may be generated as in Figure 5 (a) by connecting the output of an ECL gate to its out-of-phase input, by using the  $V_{BB}$  pin of certain ECL devices such as SN10115, or by other methods. An unused out-of-phase input may be connected low or connected to the other out-of-phase input of the same gate in many applications. Function tables for many of these applications are shown in Figure 6.

The fast switching speeds of the SN75368 may produce undesirable output transient overshoot because of load or wiring inductance. A small series damping resistor may be used to reduce or eliminate this output transient overshoot. The optimum value of the damping resistor depends on the overall load characteristics and switching speed. A typical value would be between  $10 \Omega$  and  $30 \Omega$ . See Figure 7.



## MOS MEMORY INTERFACE

- Dual Inverting MOS Driver
- Low Standby Power Dissipation
- Versatile Interface Circuit for Use between TTL Levels and Level-Shifted High-Current, High-Voltage Systems
- Inputs May Be Level-Shifted by Use of a Current Source or Capacitive Coupling or Driven Directly by a Voltage Source
- Designed to Be Functionally Interchangeable with National DS0026
- Capable of Driving High-Capacitance Loads
- Compatible with Many Popular MOS RAMs and MOS Shift Registers
- $V_{CC}$  Supply Voltage Variable over Wide Range to 22 Volts Maximum with Respect to  $V_{EE}$
- Operates from Standard Bipolar and/or MOS Supply Voltage
- High-Speed Switching
- Transient Overdrive Minimizes Power Dissipation

### description

The SN75369 is a monolithic dual MOS driver and interface circuit that operates with either current-source or voltage-source input signals. The device accepts appropriate level-shifted input signals from TTL or other logic systems and provides high-current and high-voltage output levels suitable for driving MOS circuits. Specifically, it may be used to drive address, control, and/or timing inputs for several types of MOS RAMs and MOS shift registers.

The SN75369 operates from standard MOS and/or bipolar supplies in most applications. This device has been optimized for operation with  $V_{CC}$  supply voltage from 12 volts to 20 volts positive with respect to  $V_{EE}$ . However, it is designed so as to be usable over a wide range of  $V_{CC}$ .

Inputs of the SN75369 are referenced to the  $V_{EE}$  terminal and contain a series current-limiting resistor. The device will operate with either positive current input signals or voltage input signals that are positive with respect to  $V_{EE}$ . In many applications the  $V_{EE}$  terminal is connected to the MOS  $V_{DD}$  supply of -12 volts to -15 volts with the inputs to be driven from TTL levels or other positive voltage levels. The required negative-level shifting may be done with an external p-n-p transistor current source or by use of capacitive coupling and appropriate input voltage pulse characteristics.

The SN75369 is characterized for operation from 0°C to 70°C.

JG OR P  
DUAL-IN-LINE PACKAGE (TOP VIEW)

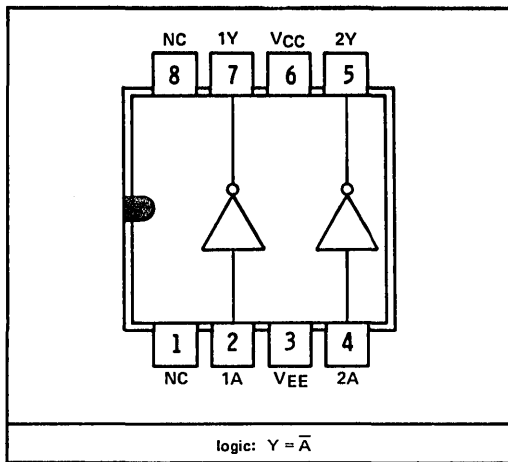

NC - No internal connection

# TYPE SN75369 DUAL MOS DRIVER

## schematics of inputs and outputs

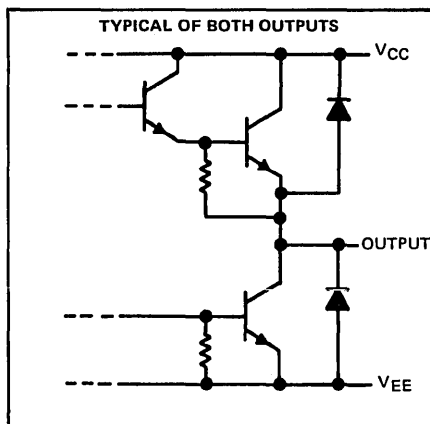
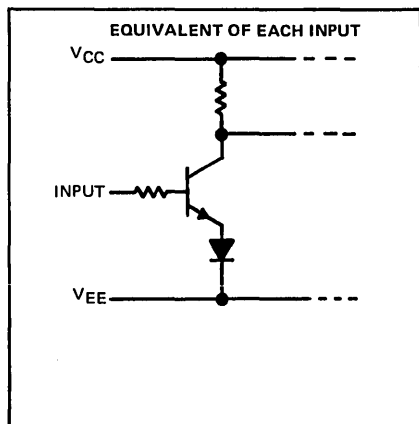

## absolute maximum ratings over operating free-air temperature range (unless otherwise noted)

Supply voltage range of $V_{CC}$ (see Note 1)	.....	-0.5 V to 22 V
Input voltage	.....	5.5 V
Continuous total dissipation at (or below) 25°C free-air temperature (see Note 2):		
JG package	.....	825 mW
P package	.....	1000 mW
Operating free-air temperature range	.....	0°C to 70°C
Storage temperature range	.....	-65°C to 150°C
Lead temperature 1/16 inch from case for 60 seconds: JG package	.....	300°C
Lead temperature 1/16 inch from case for 10 seconds: P package	.....	260°C

- NOTES: 1. Voltage values are with respect to the  $V_{EE}$  terminal unless otherwise noted.  
 2. For operation above 25°C free-air temperature, refer to Dissipation Derating Curves in the Thermal Information section, which starts on page 2-1. In the JG package, SN75369 chips are glass-mounted.

## recommended operating conditions

	MIN	NOM	MAX	UNIT
Supply voltage, $V_{CC}$	4.75	20	22	V
Operating free-air temperature, $T_A$	0		70	°C

## definition of input logic levels

PARAMETER	MIN	TYP	MAX	UNIT
$V_{IH}$ High-level input voltage	2.5		4.5	V
$V_{IL}$ Low-level input voltage			0.5	V
$I_{IH}$ High-level input current	8		20	mA
$I_{IL}$ Low-level input current			27	mA



# TYPE SN75369 DUAL MOS DRIVER

electrical characteristics over recommended ranges of  $V_{CC}$  and operating free-air temperature (unless otherwise noted)

PARAMETER		TEST CONDITIONS (See Note 3)		MIN	TYP†	MAX	UNIT	
$V_{IK}$	Input clamp voltage	$I_I = -15 \text{ mA}$				-1.5	V	
$V_{OH}$	High-level output voltage	$V_{IL} = 0.5 \text{ V},$	$I_{OH} = -50 \mu\text{A}$	$V_{CC}-1$	$V_{CC}-0.7$		V	
		$I_{IL} = 0.7 \text{ mA},$	$I_{OH} = -50 \mu\text{A}$					
		$V_{IL} = 0.5 \text{ V},$	$I_{OH} = -10 \text{ mA}$	$V_{CC}-2.3$	$V_{CC}-1.8$			
		$I_{IL} = 0.7 \text{ mA},$	$I_{OH} = -10 \text{ mA}$					
$V_{OL}$	Low-level output voltage	$V_{IH} = 2.5 \text{ V},$	$I_{OL} = 10 \text{ mA}$		0.15	0.3	V	
		$I_{IH} = 8 \text{ mA},$	$I_{OL} = 10 \text{ mA}$					
		$V_{CC} = 10 \text{ V to } 22 \text{ V},$	$V_{IH} = 2.5 \text{ V},$	$I_{OL} = 30 \text{ mA}$		0.2		0.4
		$V_{CC} = 10 \text{ V to } 22 \text{ V},$	$I_{IH} = 8 \text{ mA},$	$I_{OL} = 30 \text{ mA}$				
$V_{OK}$	Output clamp voltage	$V_I = 0 \text{ V},$				$V_{CC}+1.5$	V	
$V_I$	Input voltage	$I_I = 20 \text{ mA}$			3.7	5	V	
		$I_I = 8 \text{ mA}$			2.4	3		
		$I_I = 0.7 \text{ mA}$			0.4	0.6		
$I_I$	Input current	$V_I = 4.5 \text{ V}$			27	45	mA	
		$V_I = 2.5 \text{ V}$			9	15		
		$V_I = 0.5 \text{ V}$				1.5		
$I_{CC(H)}$	Supply current from $V_{CC}$ , both outputs high	$V_{CC} = 22 \text{ V},$ Both inputs at 0 V, No load				0.5	mA	
$I_{CC(L)}$	Supply current from $V_{CC}$ , both outputs low	$V_{CC} = 22 \text{ V},$ Both inputs at 3 V, No load			7	12	mA	

† All typical values are at  $V_{CC} = 20 \text{ V}$  and  $T_A = 25^\circ\text{C}$ .

NOTE 3: Many of these parameters are specified independently for either voltage source or current source external forcing functions at the inputs. Use the appropriate set of specifications for each application.

switching characteristics,  $V_{CC} = 20 \text{ V}, T_A = 25^\circ\text{C}$

PARAMETER		TEST CONDITIONS	MIN	TYP	MAX	UNIT
$t_{DLH}$	Delay time, low-to-high level output	$C_L = 390 \text{ pF},$ $R_D = 10 \Omega,$ See Figure 1	8	16	24	ns
$t_{DHL}$	Delay time, high-to-low-level output		4	11	20	ns
$t_{TLH}$	Transition time, low-to-high-level output		8	18	30	ns
$t_{THL}$	Transition time, high-to-low-level output		6	16	30	ns
$t_{PLH}$	Propagation delay time, low-to-high-level output		16	35	54	ns
$t_{PHL}$	Propagation delay time, high-to-low-level output		10	28	50	ns

# TYPE SN75369 DUAL MOS DRIVER

## PARAMETER MEASUREMENT INFORMATION

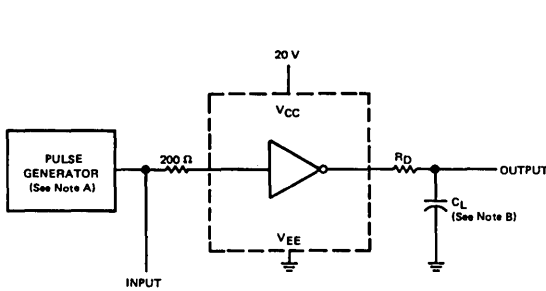

TEST CIRCUIT

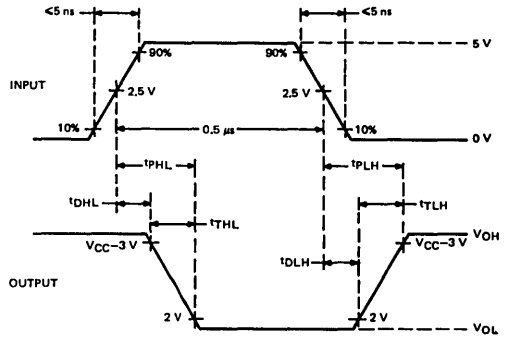

VOLTAGE WAVEFORMS

NOTES: A. The pulse generator has the following characteristics: PRR = 1 MHz, Z<sub>Out</sub> ≈ 50 Ω.  
B. C<sub>L</sub> includes probe and jig capacitance.

FIGURE 1—SWITCHING TIMES, EACH DRIVER

## TYPICAL CHARACTERISTICS

TOTAL DISSIPATION  
(BOTH DRIVERS)  
vs  
FREQUENCY

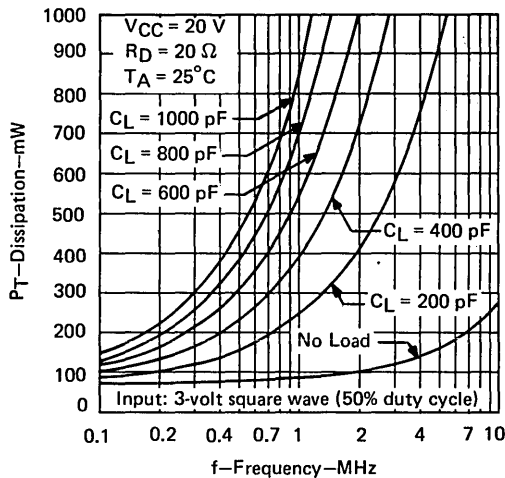

FIGURE 2

# TYPE SN75369 DUAL MOS DRIVER

## TYPICAL APPLICATION DATA

Applications of the SN75369 used as an interface device in systems converting TTL signals to negative-polarity MOS clock signals are shown in Figures 3 and 4. In both applications the SN75369  $V_{EE}$  pin is connected to a negative MOS supply voltage. Figure 3 and 4 show the use of the SN75369 over a wide range of  $V_{CC}$  supply voltages. The device may even be used as a TTL level driver, if desired, by connecting  $V_{CC}$  to 5 volts.

Both applications shown require negative level shifting from positive voltage levels to the inputs of the SN75369, which are referenced to the  $V_{EE}$  terminal. A p-n-p transistor current source is used to level shift in Figure 3. Resistor R sets the current and an open-collector TTL gate is used to switch the p-n-p transistor. Figure 4 shows capacitive coupling being used to level shift. The SN7437 TTL buffer gate is used as a voltage source driver with pull-up resistor R providing additional high-level drive. The value of coupling capacitor C depends on the frequency and characteristics of the signal applied to the capacitor.

The fast switching speeds of the SN75369 may produce undesirable output transient overshoot because of load or wiring inductance. A small series damping resistor may be used to reduce or eliminate this output transient overshoot. The optimum value of the damping resistor depends on the specific load characteristics and switching speed. A typical value would be between  $10\ \Omega$  and  $30\ \Omega$ . See Figure 5.

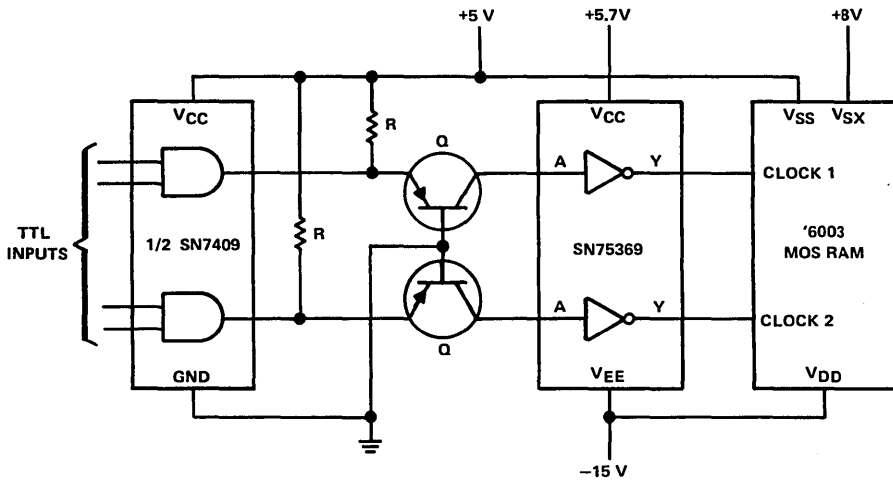

- NOTES: A.  $R \approx 350\ \Omega$  to  $500\ \Omega$ .  
B. Q is 2N3829 or equivalent.

FIGURE 3—MOS RAM CLOCK DRIVER SYSTEM WITH P-N-P TRANSISTOR CURRENT SOURCE USED TO SHIFT LEVELS TO INPUTS OF SN75369

# TYPE SN75369 DUAL MOS DRIVER

## TYPICAL APPLICATION DATA

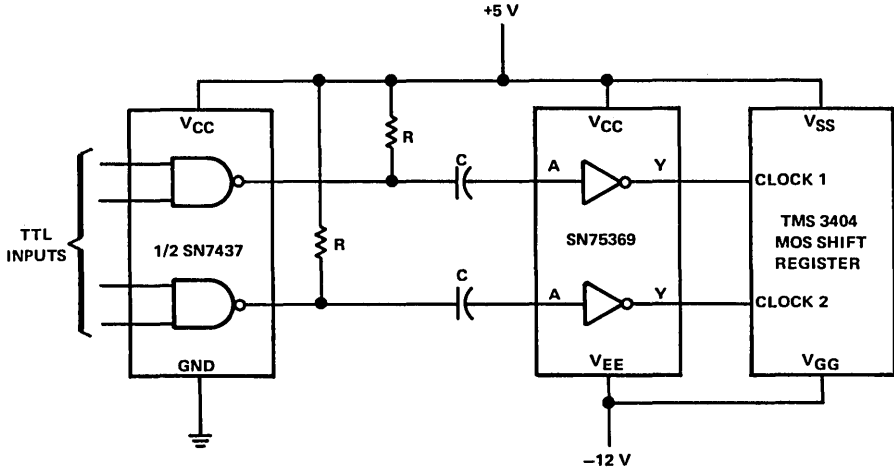

NOTE A:  $R \approx 100 \Omega$  to  $250 \Omega$ .

FIGURE 4—MOS SHIFT REGISTER CLOCK DRIVER SYSTEM WITH CAPACITIVE COUPLING USED TO SHIFT LEVELS TO INPUTS OF SN75369

7

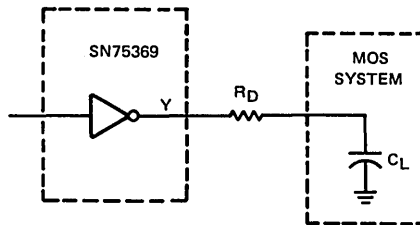

NOTE:  $R_D \approx 10 \Omega$  to  $30 \Omega$  (optional)

FIGURE 5—USE OF DAMPING RESISTOR TO REDUCE OR ELIMINATE OUTPUT TRANSIENT OVERSHOOT IN CERTAIN SN75369 APPLICATIONS

# INTERFACE CIRCUITS

# TYPE SN75370 DUAL-CHANNEL INTERFACE TO MOS MEMORIES

BULLETIN NO. DL-S 7712059, SEPTEMBER 1973 — REVISED APRIL 1977

## DUAL READ/WRITE AMPLIFIER FOR INTERFACING BETWEEN TTL AND TMS4062-TYPE MOS RANDOM-ACCESS MEMORY (RAM)

### performance features

- Node Terminals Connect Directly to I/O Terminals of TMS4062 (AMS6002) and Similar MOS RAMs
- In Write Mode, Write Driver Provides Complementary High-Voltage Outputs at Node Terminals
- In Read Mode, Read Amplifier Responds to Small Differential-Input Current in Node Terminals

### description

The SN75370 is a monolithic integrated circuit read/write amplifier that is designed to interface the Input/Output (I/O) terminals of the TMS4062 (AMS6002) and similar type MOS RAMs with TTL.

The device contains two separate channels. Each channel consists of a write driver and a read amplifier, which are common at the input/output node (N) terminals. These terminals are outputs for the write driver and inputs for the read amplifier. In the write mode, the write driver circuit is designed to write MOS-level binary information into the MOS RAM under control of TTL inputs. In the read mode, the read amplifier is designed to read MOS-level binary information from the MOS RAM and convert it to TTL levels at the data output. This is controlled by TTL inputs also.

Data outputs are constructed so that they may be wire-AND connected to other outputs and/or be connected to an external pull-up resistor, if desired. The device has a chip-enable input common to both channels which can be used to enable the entire device. Internal voltage regulators permit circuit operation over a wide range of supply voltages.

### ease of design features

- TTL and DTL Compatible Diode-Clamped Inputs
- TTL and DTL Compatible Data Outputs
- 50-mA Data Output Sink-Current Capability
- Data Outputs May Be Wire-AND Connected
- Operates Over Wide Range of Supply Voltages
- Minimizes or Eliminates External Components

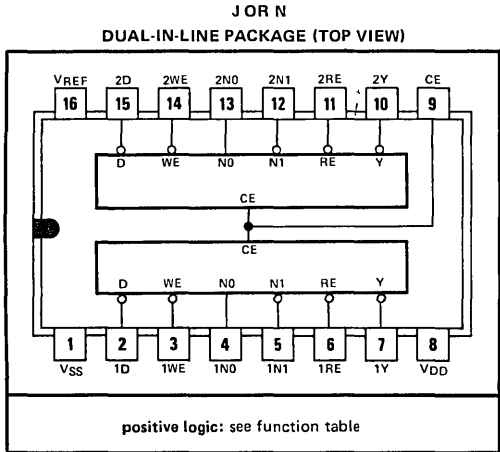

### functional block diagram (each channel)

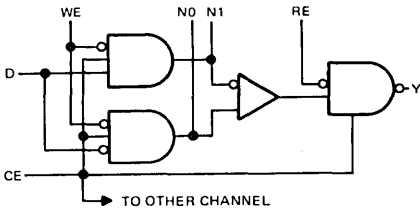

FUNCTION TABLE

MODE	VOLTAGE INPUTS				VOLTAGE OUTPUTS		DIFFERENTIAL CURRENT INPUT N1-N0	OUTPUT Y
	CE	WE	RE	D	NO	N1		
Write 0	H	L	H	L	H	L	X	H
Write 1	H	L	H	H	L	L	X	H
Read 0	H	H	L	X	L	L	L	L
Read 1	H	H	L	X	L	L	H	H
Standby	H	H	H	X	L	L	X	H
Disabled	L	X	X	X	L	L	X	Off

H = high level (voltage or current), L = low level (voltage or current), X = irrelevant. Input levels at CE, WE, RE, and D, and output levels at Y are TTL-compatible. Voltage output levels at N fall between  $V_{SS}$  and  $V_{REF}$ .

**TYPE SN75370  
DUAL-CHANNEL INTERFACE TO MOS MEMORIES**

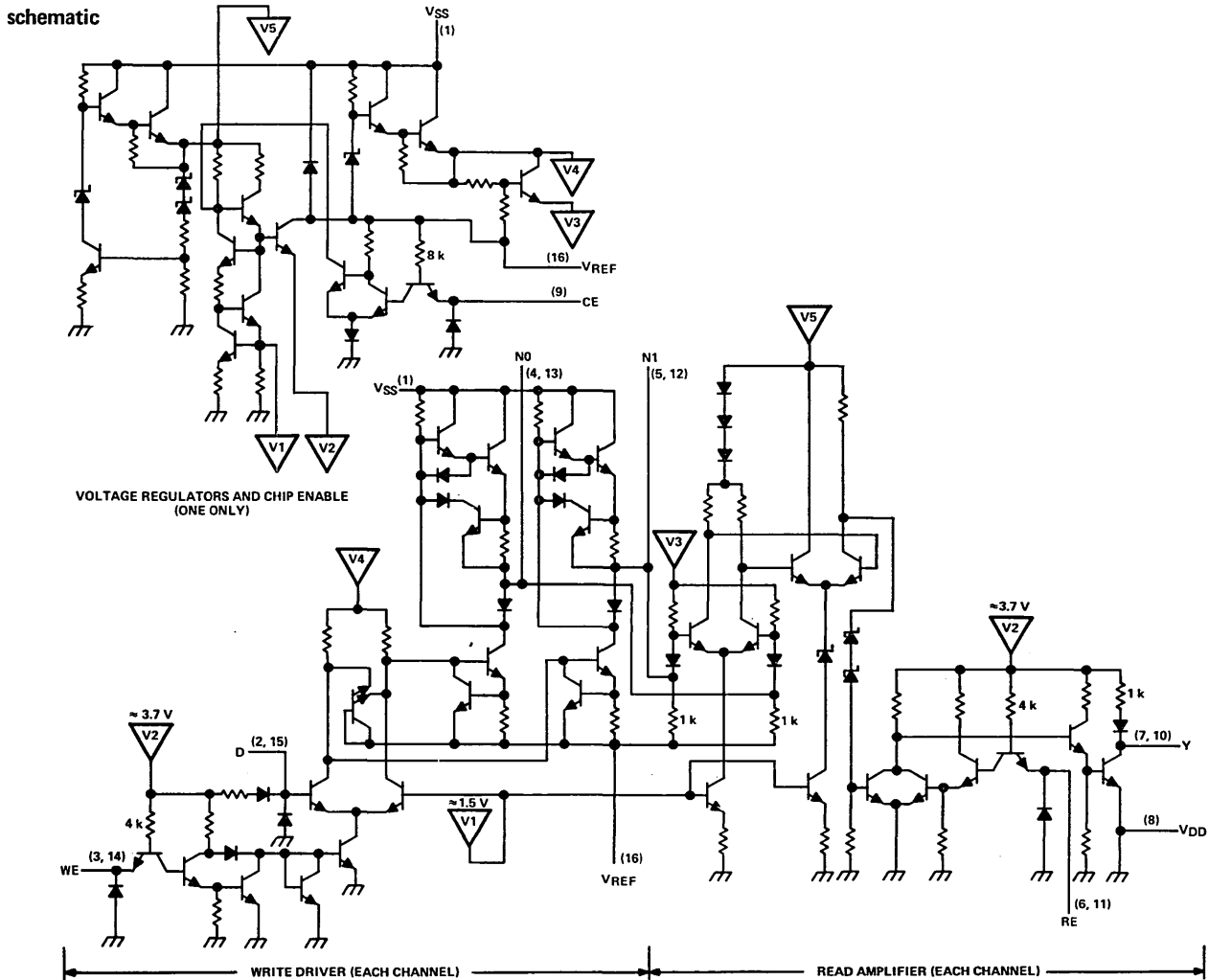

NOTES: A. Resistor values shown are nominal and in ohms.  
 B. Internally regulated voltages, V<sub>1</sub>, V<sub>2</sub>, V<sub>3</sub>, V<sub>4</sub>, and V<sub>5</sub> are connected to the designated points on both read/write channels.

# TYPE SN75370

## DUAL-CHANNEL INTERFACE TO MOS MEMORIES

absolute maximum ratings over operating free-air temperature range (unless otherwise noted)

Supply voltage range, $V_{SS}$ (see Note 1)	-0.5 V to 25 V
Supply voltage range, $V_{REF}$	-0.5 V to 15 V
Voltage-difference range between supply voltages, $V_{SS}-V_{REF}$	-0.5 V to 20 V
Input voltage at CE, WE, RE, or D	5.5 V
Output voltage at Y	7 V
Continuous output current into Y	50 mA
Continuous current into any node terminal	$\pm 40$ mA
Continuous total dissipation at (or below) 25°C free-air temperature (see Note 2): J package	1025 mW
N package	1150 mW
Operating free-air temperature range	0°C to 70°C
Storage temperature range	-65°C to 150°C
Lead temperature 1/16 inch from case for 60 seconds: J package	300°C
Lead temperature 1/16 inch from case for 10 seconds: N package	260°C

- NOTES: 1. Voltage values are with respect to the  $V_{DD}$  terminal unless otherwise noted.  
 2. For operation above 25°C free-air temperature, refer to Dissipation Derating Curves in the Thermal Information section, which starts on page 2-1. In the J package, SN75370 chips are glass-mounted.

recommended operating conditions

	MIN	NOM	MAX	UNIT
Supply voltage, $V_{SS}$	17	20	22	V
Supply voltage, $V_{REF}$	4.5	7	10	V
Voltage difference between supply voltages, $V_{SS}-V_{REF}$	8	13	16	V
Operating free-air temperature, $T_A$	0		70	°C

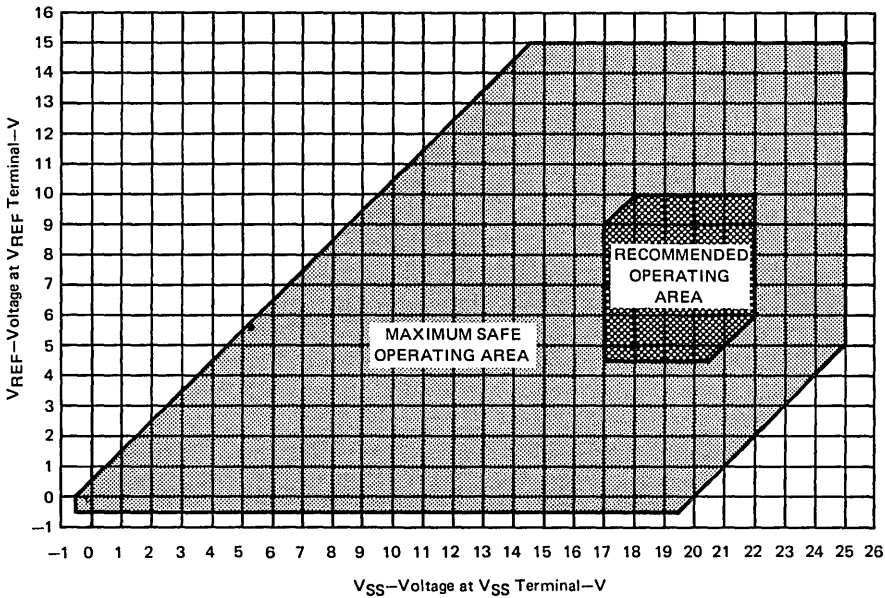

FIGURE 1—MAXIMUM SAFE OPERATING AREA AND RECOMMENDED OPERATING AREA

# TYPE SN75370

## DUAL-CHANNEL INTERFACE TO MOS MEMORIES

### definition of input logic levels

PARAMETER		B (LEAST POSITIVE)	A (MOST POSITIVE)	UNIT
$V_{IH}$	High-level input voltage at CE, WE, RE, or D	2		V
$V_{IL}$	Low-level input voltage at CE, WE, RE, or D		0.8	V
$I_{IDH}$	High-level differential input current in node terminals (see Note 3)	50		$\mu\text{A}$
$I_{IDL}$	Low-level differential input current in node terminals (see Note 3)		-50	$\mu\text{A}$

NOTE 3:  $I_{ID} = I_{N1} - I_{N0}$  with current into a terminal being a positive value.

### electrical characteristics over recommended ranges of $V_{SS}$ , $V_{REF}$ , and operating free-air temperature (unless otherwise noted)

PARAMETER	TEST FIGURE	TEST CONDITIONS	MIN	TYP†	MAX	UNIT	
$V_{IK}$	2	$I_I = -12 \text{ mA}$			-1.5	V	
$V_{ONH}$	3	$V_{IH} = 2 \text{ V}, V_{IL} = 0.8 \text{ V}, I_{NH} = 0$	$V_{SS}-2$	$V_{SS}-1.6$		V	
		$V_{IH} = 2 \text{ V}, V_{IL} = 0.8 \text{ V}, I_{NH} = -40 \text{ mA}$	$V_{SS}-3$	$V_{SS}-2$			
$V_{ONL}$	3	$V_{IH} = 2 \text{ V}, V_{IL} = 0.8 \text{ V}, I_{NL} = 0$	$V_{REF}$	$V_{REF}+0.2$	$V_{REF}+1$	V	
		$V_{IH} = 2 \text{ V}, V_{IL} = 0.8 \text{ V}, I_{NL} = 20 \text{ mA}$	$V_{REF}$	$V_{REF}+1.2$	$V_{REF}+2$		
$I_{OH}$	4	$V_{IH} = 2 \text{ V}, V_{IL} = 0.8 \text{ V}, I_{IDH} = 50 \mu\text{A}, V_{OH} = 5.5 \text{ V}$			100	$\mu\text{A}$	
$V_{OH}$	4	$V_{IH} = 2 \text{ V}, V_{IL} = 0.8 \text{ V}, I_{IDH} = 50 \mu\text{A}, I_{OH} = -200 \mu\text{A}$	2.2	2.8	4.5	V	
$V_{OL}$	4	$V_{IH} = 2 \text{ V}, V_{IL} = 0.8 \text{ V}, I_{IDL} = -50 \mu\text{A}, I_{OL} = 50 \text{ mA}$		0.25	0.4	V	
$I_I$	5	$V_I = 5.5 \text{ V}$			1	mA	
$I_{IH}$	5	$V_I = 2.4 \text{ V}$			40	$\mu\text{A}$	
$I_{IH}$	5	$V_I = 2.4 \text{ V}$		-150	+80 -600	$\mu\text{A}$	
$I_{IL}$	2	$V_I = 0.4 \text{ V}$		-0.7	-1.6	mA	
$r_N$	6	$V_{SS}$ open, $V_{REF} = 0, I_N = 500 \mu\text{A}, T_A = 25^\circ\text{C}$	0.7	1‡	1.3	$\text{k}\Omega$	
$I_{OS}$	7	$V_O = 0 \text{ V}$	CE at 2 V		-3.2	-4.5	mA
			CE at 0.8 V			-1	

See next page for supply current and dissipation.

† All typical values, except for  $r_N$  and  $I_{REF}(D, O)$ , are at  $V_{SS} = 20 \text{ V}, V_{REF} = 7 \text{ V}, T_A = 25^\circ\text{C}$ .

‡ Typical value of  $r_N$  is with  $V_{SS}$  open,  $V_{REF} = 0 \text{ V}, T_A = 25^\circ\text{C}$ .



# TYPE SN75370

## DUAL-CHANNEL INTERFACE TO MOS MEMORIES

supply current and dissipation over operating free-air temperature range (unless otherwise noted)

PARAMETER		MODE	TEST FIGURE	TEST CONDITIONS	MIN	TYP†	MAX	UNIT
I <sub>SS(D)</sub>	Current from V <sub>SS</sub>	Disabled	8	V <sub>SS</sub> = 20 V, V <sub>REF</sub> = 7 V	27	35		mA
I <sub>REF(D)</sub>	Current from V <sub>REF</sub>				-20	-25		mA
P <sub>D</sub>	Dissipation				410	500		mW
I <sub>SS(SB)</sub>	Current from V <sub>SS</sub>	Standby	8	V <sub>SS</sub> = 20 V, V <sub>REF</sub> = 7 V	31	39		mA
I <sub>REF(SB)</sub>	Current from V <sub>REF</sub>				-12	-18		mA
P <sub>SB</sub>	Dissipation				560	690		mW
I <sub>SS(R1)</sub>	Current from V <sub>SS</sub>	Read-1	8	V <sub>SS</sub> = 20 V, V <sub>REF</sub> = 7 V, I <sub>N1</sub> = 100 μA	31	39		mA
I <sub>REF(R1)</sub>	Current from V <sub>REF</sub>				-12	-18		mA
P <sub>R1</sub>	Dissipation				540	690		mW
I <sub>SS(R0)</sub>	Current from V <sub>SS</sub>	Read-0	8	V <sub>SS</sub> = 20 V, V <sub>REF</sub> = 7 V, I <sub>N0</sub> = 100 μA	31	39		mA
I <sub>REF(R0)</sub>	Current from V <sub>REF</sub>				4	10		mA
P <sub>R0</sub>	Dissipation				640	790		mW
I <sub>SS(W)</sub>	Current from V <sub>SS</sub>	Write	8	V <sub>SS</sub> = 20 V, V <sub>REF</sub> = 7 V, See Note 4	53	66		mA
I <sub>REF(W)</sub>	Current from V <sub>REF</sub>				-23	-31		mA
P <sub>W</sub>	Dissipation				910	1100		mW
I <sub>REF(D, O)</sub>	Current from V <sub>REF</sub>	Disabled, V <sub>SS</sub> -open	8	V <sub>SS</sub> open, V <sub>REF</sub> = 10 V	2‡	5		mA

†All typical values, except for r<sub>N</sub> and I<sub>REF(D, O)</sub>, are at V<sub>SS</sub> = 20 V, V<sub>REF</sub> = 7 V, T<sub>A</sub> = 25°C.

‡Typical value of I<sub>REF(D, O)</sub> is with V<sub>SS</sub> open, V<sub>REF</sub> = 7 V, T<sub>A</sub> = 25°C.

NOTE 4: Duty cycle in the write mode must be low enough to maintain the average dissipation within the continuous dissipation rated limit when averaged over short intervals.

switching characteristics, V<sub>SS</sub> = 20 V, V<sub>REF</sub> = 7 V, C<sub>I/O</sub> = 40 pF, C<sub>L</sub> = 15 pF, R<sub>L</sub> = 400 Ω, T<sub>A</sub> = 25°C

PARAMETER†	FROM (INPUT)	TO (OUTPUT)	TEST FIGURE	TEST CONDITIONS	MIN	TYP	MAX	UNIT
t <sub>PLH</sub>	WE	N	10		52	80		ns
t <sub>PHL</sub>					31	47		
t <sub>PLH</sub>	D	N	11		44	70		ns
t <sub>PHL</sub>					30	45		
t <sub>PLH</sub>	CE	N	12		60	95		ns
t <sub>PHL</sub>					43	65		
t <sub>PLH</sub>	RE	Y	13	I <sub>ID</sub> = -100 μA	13	20		ns
t <sub>PHL</sub>					19	28		
t <sub>PLH</sub>	CE	Y	14	I <sub>ID</sub> = -100 μA	25	38		ns
t <sub>PHL</sub>					32	48		
t <sub>PLH</sub>	N0	Y	15		25	40		ns
t <sub>PHL</sub>					25	40		
t <sub>PLH</sub>	N1	Y	16		25	40		ns
t <sub>PHL</sub>					25	40		
t <sub>PLH</sub>	WE	Y	17	I <sub>N1</sub> = 100 μA	135	190		ns
t <sub>PHL</sub>				I <sub>N0</sub> = 100 μA	125	190		

†t<sub>PLH</sub> = propagation delay time, low-to-high-level output

t<sub>PHL</sub> = propagation delay time, high-to-low-level output

# TYPE SN75370 DUAL-CHANNEL INTERFACE TO MOS MEMORIES

## PARAMETER MEASUREMENT INFORMATION

d-c test circuits†

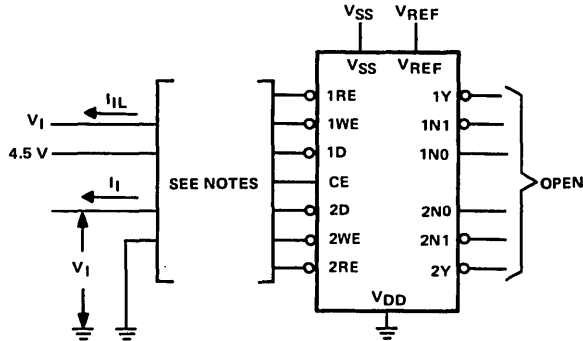

NOTES: A. WE, RE, and D inputs are tested for two conditions of CE: CE at 4.5 V and CE at 0 V.  
B. When WE is low, these parameters must be measured using pulse techniques.  $t_w = 200 \mu s$ , duty cycle  $< 20\%$ .

FIGURE 2— $V_I$  and  $I_{IL}$

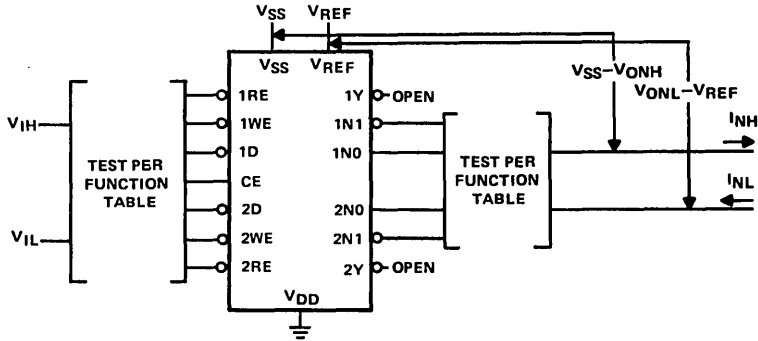

NOTE A: When WE is low, these parameters must be measured using pulse techniques.  $t_w = 200 \mu s$ , duty cycle  $< 20\%$ .

FIGURE 3— $V_{IH}$ ,  $V_{IL}$ ,  $V_{ONH}$ , and  $V_{ONL}$

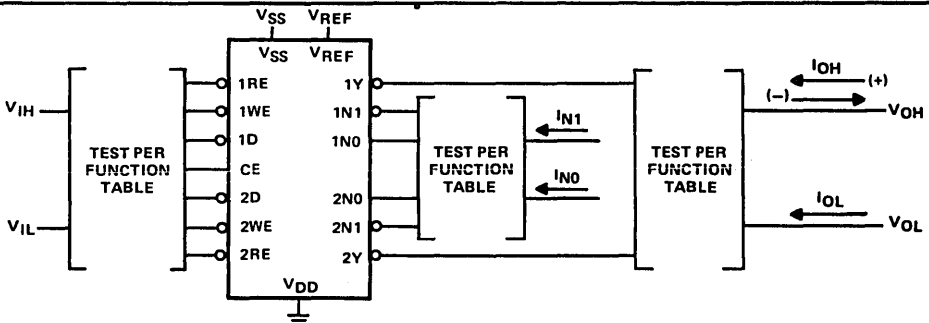

NOTES: A. I/O terminals are used as inputs.  
B. For testing purposes:  $I_{IDH} = I_{N1}$  with  $I_{N0} = 0$ . (Current into  $I_{N1}$  terminal only.)  
 $-I_{IDL} = I_{N0}$  with  $I_{N1} = 0$ . (Current into  $I_{N0}$  terminal only.)  
C. When WE is low, these parameters must be measured using pulse techniques.  $t_w = 200 \mu s$ , duty cycle  $< 20\%$ .

FIGURE 4— $V_{IH}$ ,  $V_{IL}$ ,  $I_{IDH}$ ,  $I_{IDL}$ ,  $V_{OH}$ ,  $V_{OL}$ ,  $I_{OH}$

†Arrows indicate actual direction of current flow. Current into a terminal is a positive value.

# TYPE SN75370

## DUAL-CHANNEL INTERFACE TO MOS MEMORIES

### PARAMETER MEASUREMENT INFORMATION

d-c test circuitst (continued)

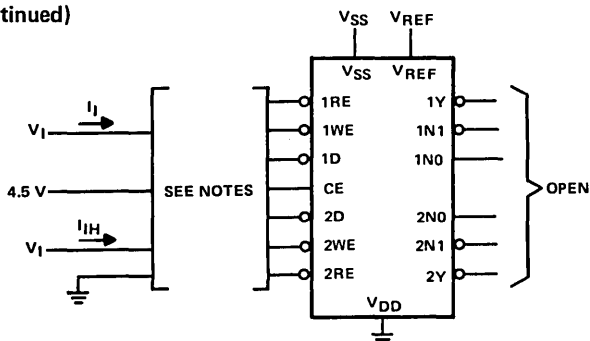

NOTES: A. WE, RE, and D inputs are tested for two conditions of CE: CE at 4.5 V and CE at 0 V.  
 B. When WE is low, these parameters must be measured using pulse techniques.  $t_w = 200 \mu s$ , duty cycle  $\leq 20\%$ .

FIGURE 5— $I_L$  and  $I_{IH}$

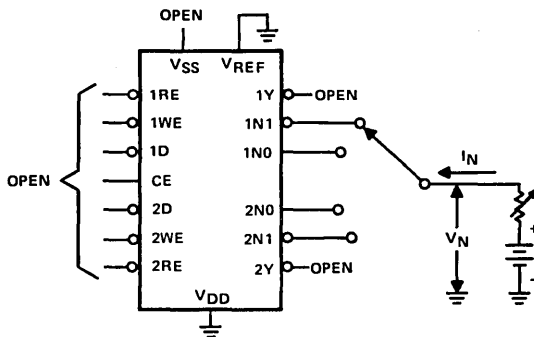

NOTE A: Resistance  $r_N$  is calculated using the equation:  $r_N = \frac{V_N}{I_N}$ .

FIGURE 6— $r_N$

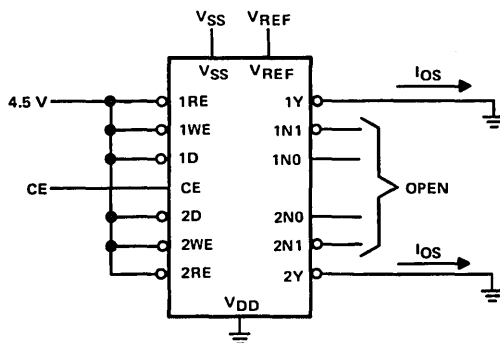

FIGURE 7— $I_{OS}$

†Arrows indicate actual direction of current flow. Current into a terminal is a positive value.

# TYPE SN75370 DUAL-CHANNEL INTERFACE TO MOS MEMORIES

## PARAMETER MEASUREMENT INFORMATION

d-c test circuits† (continued)

TEST TABLE				
MODE	CE	WE	RE	D
Disabled	0 V	0 V	0 V	4.5 V
Standby	4.5 V	4.5 V	4.5 V	4.5 V
Read-1	4.5 V	4.5 V	0 V	4.5 V
Read-0	4.5 V	4.5 V	0 V	0 V
Write	4.5 V	0 V	4.5 V	4.5 V
Disabled, V <sub>SS</sub> -open	0 V	0 V	0 V	0 V

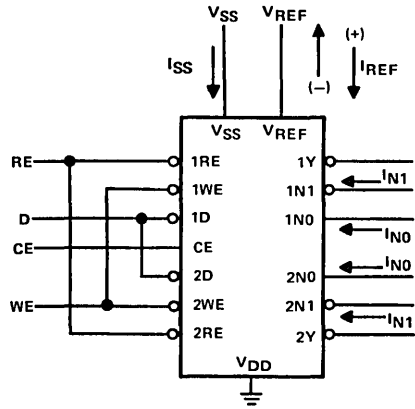

- NOTES: A.  $I_{SS}$  and  $I_{REF}$  are measured simultaneously with both halves of circuit biased identically.  
 B. All node terminals are open except as noted otherwise in test conditions.  
 C. When WE is low, these parameters must be measured using pulse techniques.  $t_w = 200 \mu s$ , duty cycle  $\leq 20\%$ .  
 D. Dissipation is calculated using the equation  $P = V_{SS} \cdot I_{SS} + V_{REF} \cdot I_{REF}$ .

FIGURE 8— $I_{SS}$ ,  $I_{REF}$ , and P

†Arrows indicate actual direction of current flow. Current into a terminal is a positive value.

## switching characteristics

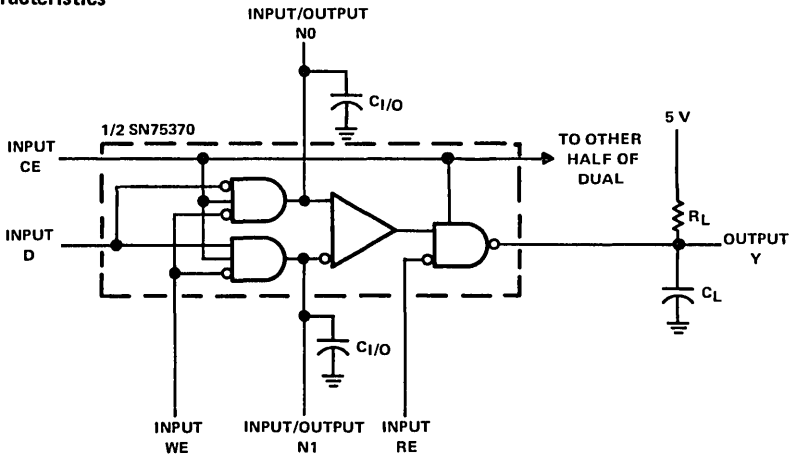

- NOTES: A. Refer to this figure and notes for all switching tests.  
 B. The pulse generator has the following characteristics: PRR = 1 MHz,  $Z_{out} \approx 50 \Omega$ .  
 C.  $C_L$  and  $C_{1/O}$  include probe and jig capacitance.  
 D. Input conditions for channel not under test: WE and RE at 2.4 V, D at 0.4 V.  
 E. N terminals are connected only to  $C_{1/O}$  unless otherwise noted.

FIGURE 9—SWITCHING TEST CIRCUIT

# TYPE SN75370 DUAL-CHANNEL INTERFACE TO MOS MEMORIES

## PARAMETER MEASUREMENT INFORMATION

switching characteristics (continued)

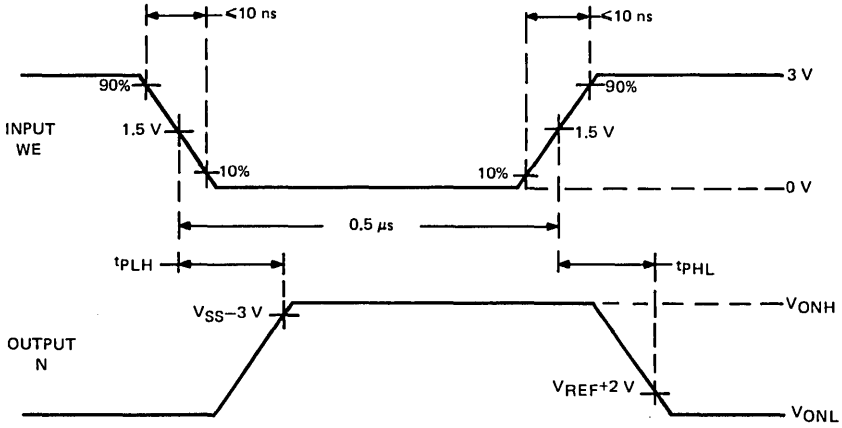

- NOTES: A. See Figure 9.  
 B. Output N0 is tested with D at 0.4 V and output N1 is tested with D at 2.4 V.  
 C. Input conditions for other inputs of channel under test: CE at 2.4 V, RE at 2.4 V.

FIGURE 10—VOLTAGE WAVEFORMS, WE TO N

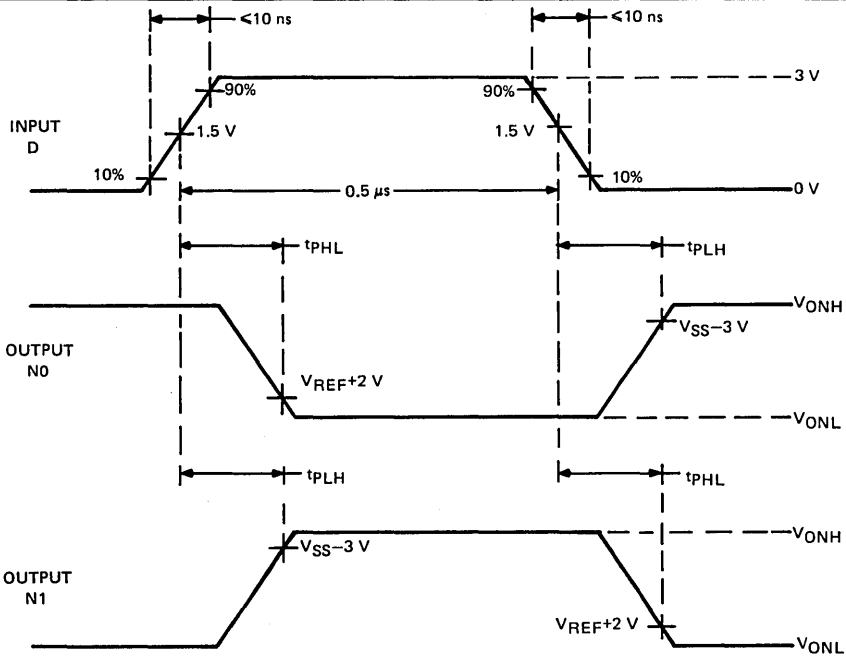

- NOTES: A. See Figure 9.  
 B. Input conditions for other inputs of channel under test: CE at 2.4 V, WE at 0.4 V, RE at 2.4 V.

FIGURE 11—VOLTAGE WAVEFORMS, D TO N

# TYPE SN75370

## DUAL-CHANNEL INTERFACE TO MOS MEMORIES

### PARAMETER MEASUREMENT INFORMATION

switching characteristics (continued)

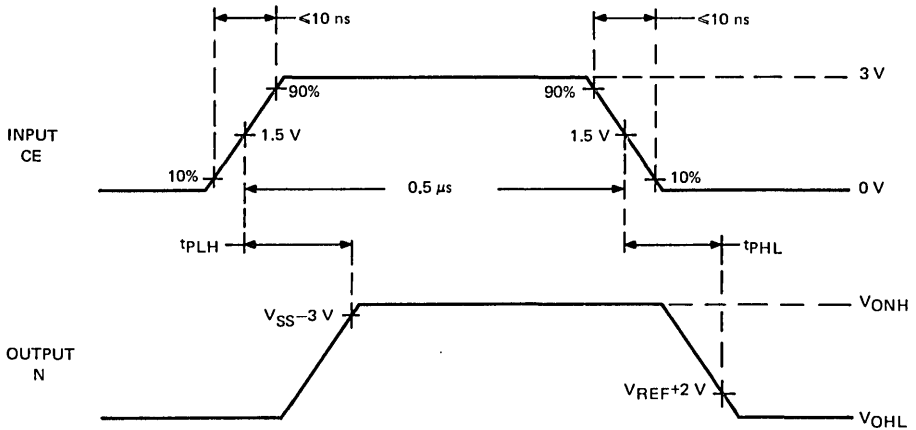

- NOTES: A. See Figure 9.  
 B. Output NO is tested with D at 0.4 V and output N1 is tested with D at 2.4 V.  
 C. Input conditions for all other inputs of channel under test: WE at 0.4 V, RE at 2.4 V.

FIGURE 12—VOLTAGE WAVEFORMS, CE TO N

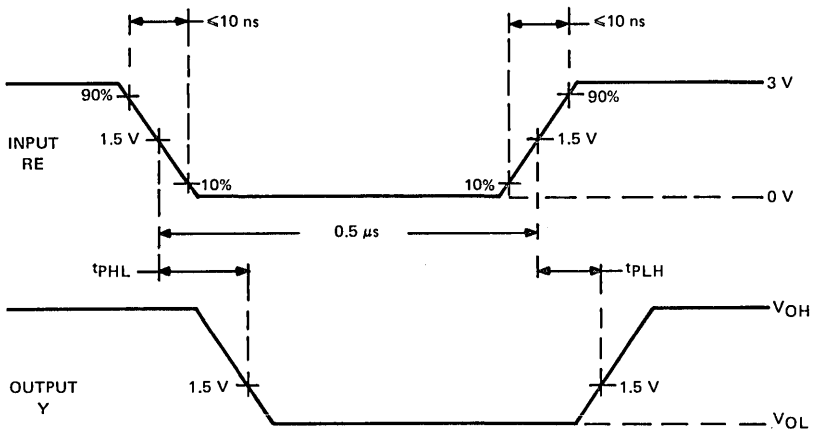

- NOTES: A. See Figure 9.  
 B. Input conditions for all other inputs of channel under test: CE at 2.4 V, WE at 2.4 V, D at 0.4 V.  
 C.  $I_{NO} = 100\ \mu\text{A}$ .

FIGURE 13—VOLTAGE WAVEFORMS, RE TO Y

# TYPE SN75370 DUAL-CHANNEL INTERFACE TO MOS MEMORIES

## PARAMETER MEASUREMENT INFORMATION

switching characteristics (continued)

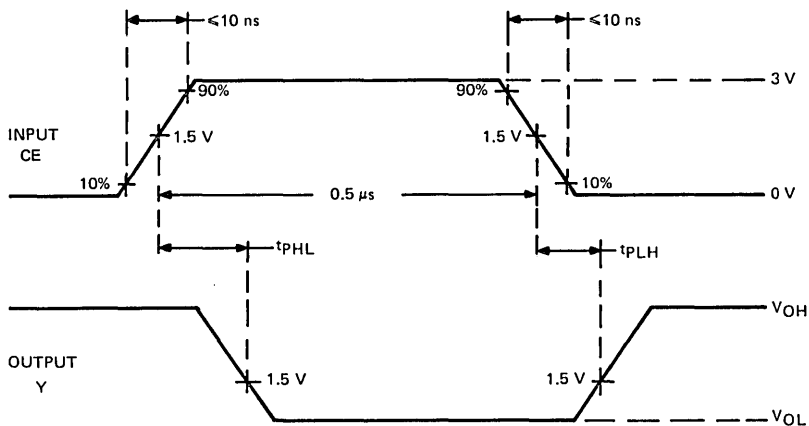

- NOTES: A. See Figure 9.  
 B. Input conditions for all other inputs of channel under test: WE at 2.4 V, RE at 0.4 V, D at 0.4 V.  
 C.  $I_{N0} = 100\ \mu\text{A}$ .

FIGURE 14—VOLTAGE WAVEFORMS, CE TO Y

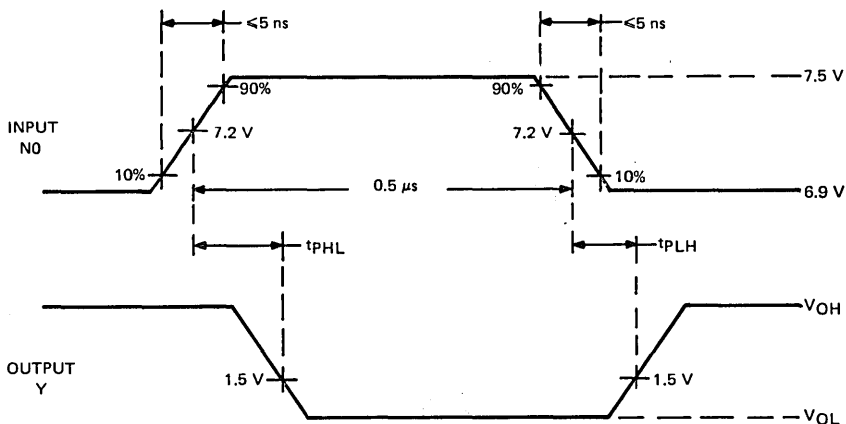

- NOTES: A. See Figure 9.  
 B. Input conditions for all other inputs of channel under test: CE at 2.4 V, WE at 2.4 V, RE at 0.4 V, D at 2.4 V.

FIGURE 15—VOLTAGE WAVEFORMS, N0 TO Y

7

# TYPE SN75370 DUAL-CHANNEL INTERFACE TO MOS MEMORIES

## PARAMETER MEASUREMENT INFORMATION

switching characteristics (continued)

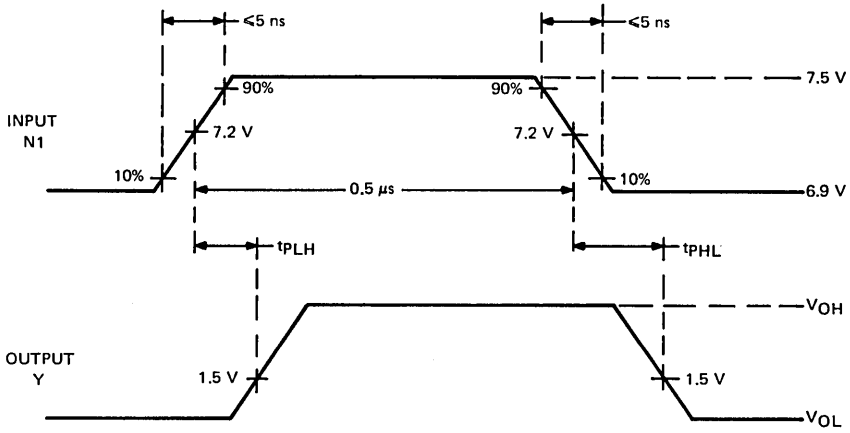

- NOTES: A. See Figure 9.  
B. Input conditions for other inputs of channel under test: CE at 2.4 V, WE at 2.4 V, RE at 0.4 V, D at 2.4 V.

FIGURE 16—VOLTAGE WAVEFORMS, N1 TO Y

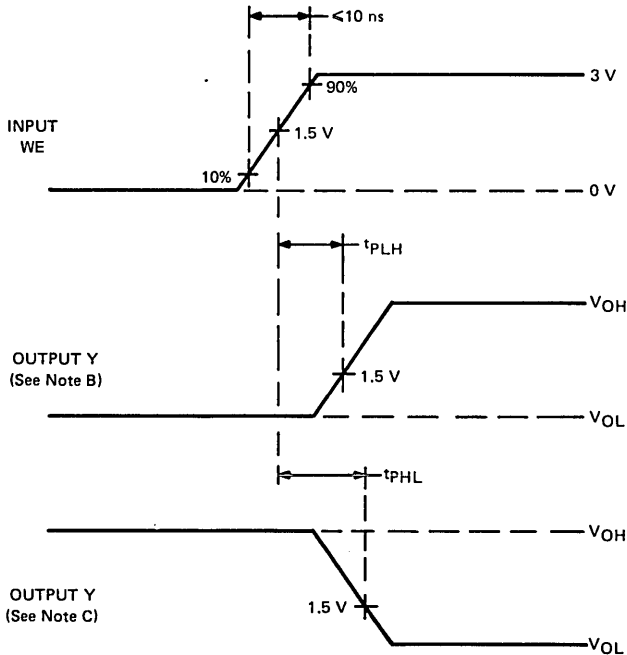

- NOTES: A. See Figure 9.  
B.  $t_{PLH}$  is tested with  $I_{N1} = 100 \mu A$ , D at 0.4 V, CE at 2.4 V, RE at 0.4 V.  
C.  $t_{PHL}$  is tested with  $I_{N0} = 100 \mu A$ , D at 2.4 V, CE at 2.4 V, RE at 0.4 V.  
D. Duty cycle of input WE pulse generator is 50%.

FIGURE 17—VOLTAGE WAVEFORMS, WE TO Y



# TYPE SN75370 DUAL-CHANNEL INTERFACE TO MOS MEMORIES

## TYPICAL CHARACTERISTICS

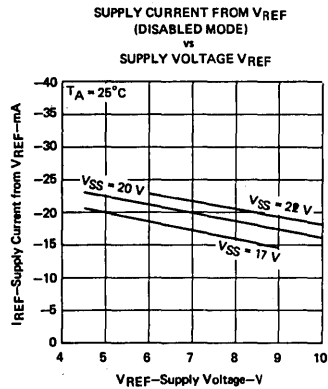
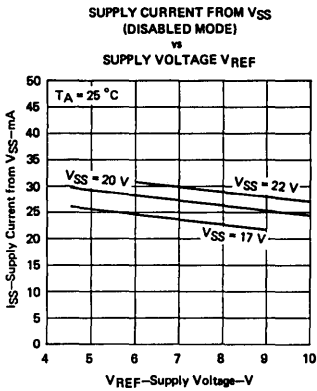
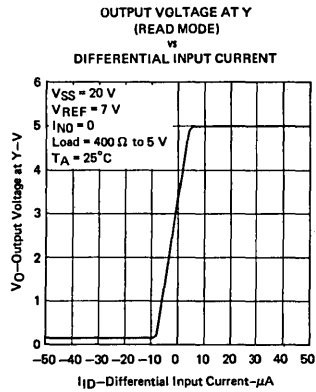
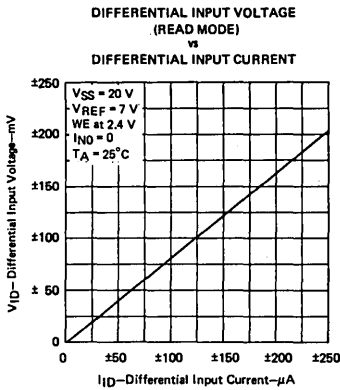
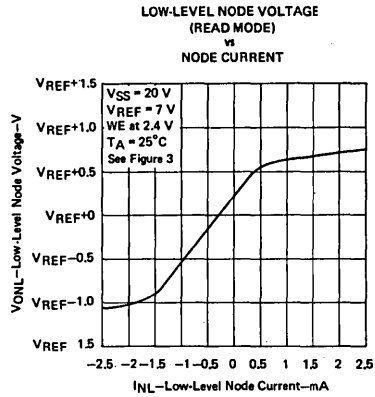
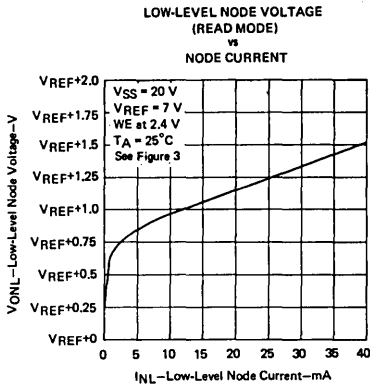

7

# TYPE SN75370

## DUAL-CHANNEL INTERFACE TO MOS MEMORIES

### TYPICAL CHARACTERISTICS

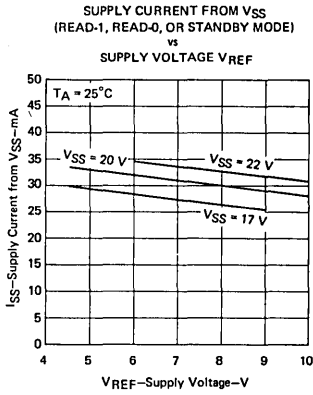

FIGURE 24

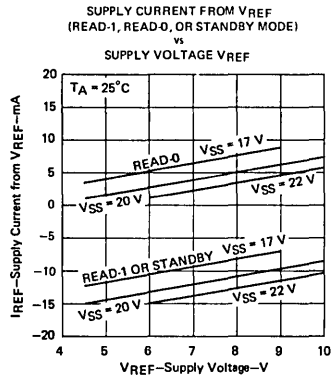

FIGURE 25

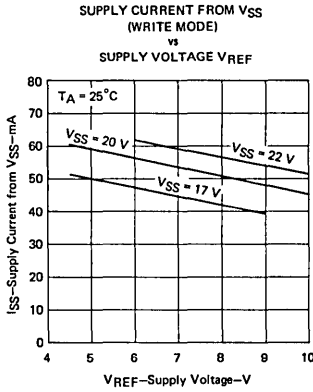

FIGURE 26

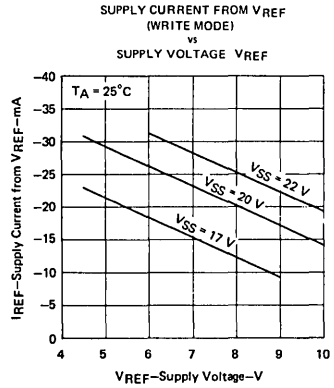

FIGURE 27

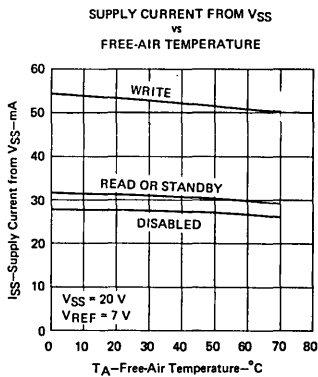

FIGURE 28

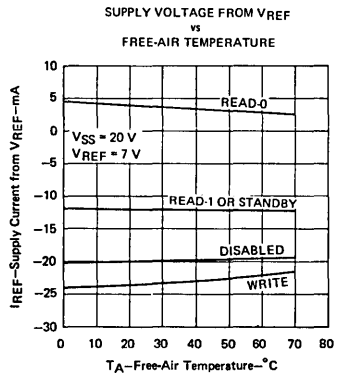

FIGURE 29

# TYPE SN75370 DUAL-CHANNEL INTERFACE TO MOS MEMORIES

## TYPICAL APPLICATION DATA

Figure 30 illustrates a typical MOS memory system using SN75370, TMS4062, and SN75361A. All inputs and outputs from this system are TTL-compatible. The SN75361A is a high-speed monolithic dual TTL-to-MOS driver. The address SN75361As select a cell in each of the 72 TMS4062s. In Figure 30 the I/O terminals of the eight TMS4062 RAMs in each row have been connected to the node terminals of the associated SN75370 channel. Time multiplexing of the column of RAMs (M) by the SN75361A Clock/CS and Reset drivers is then used to write into or read from the cells that have been selected by the address SN75361As.

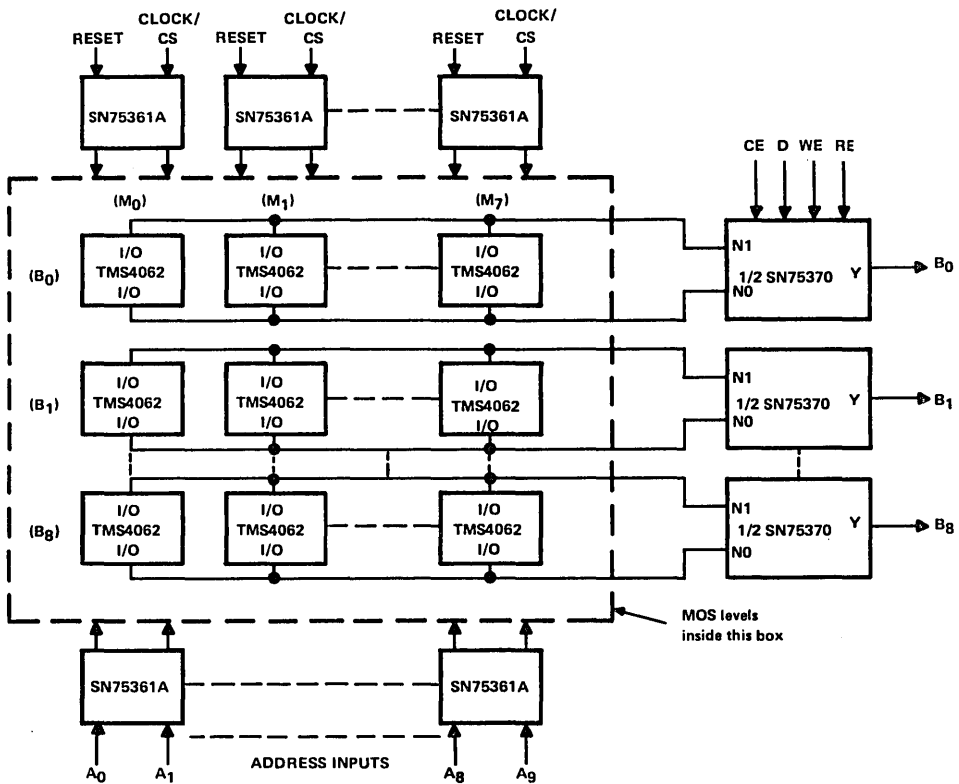

FIGURE 30—BLOCK DIAGRAM OF TOTALLY TTL-COMPATIBLE 8K X 9-BIT MOS-MEMORY SYSTEM USING SN75370, TMS4062, AND SN75361A

# TYPE SN75370 DUAL-CHANNEL INTERFACE TO MOS MEMORIES

## TYPICAL APPLICATION DATA

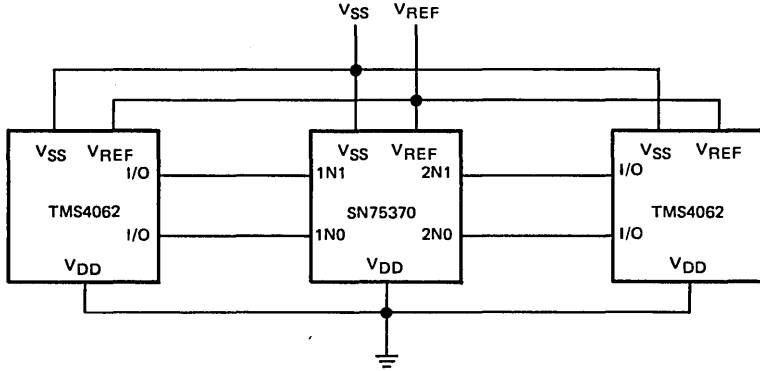
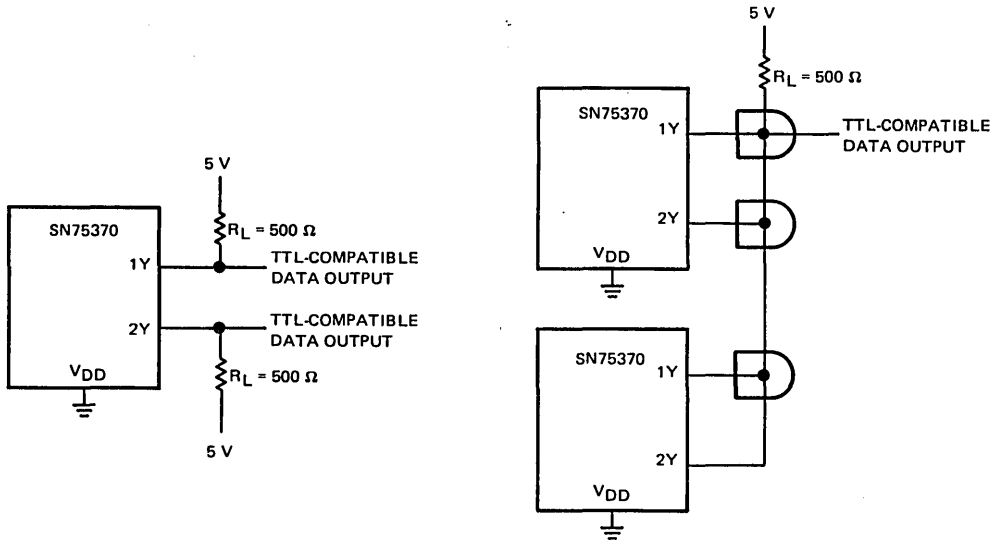

FIGURE 31—INTERCONNECTION OF SN75370 WITH TMS4062 MOS RAM



NOTE A: Pull-up resistor  $R_L$  is not necessary, but may be desirable for faster low-to-high-level transition of data output and increased TTL high-level noise margin. The value of  $R_L$  is determined by the user based upon the constraints of the system.

FIGURE 32—METHODS OF USING DATA OUTPUTS OF SN75370

# TYPE SN75370 DUAL-CHANNEL INTERFACE TO MOS MEMORIES

## TYPICAL APPLICATION DATA

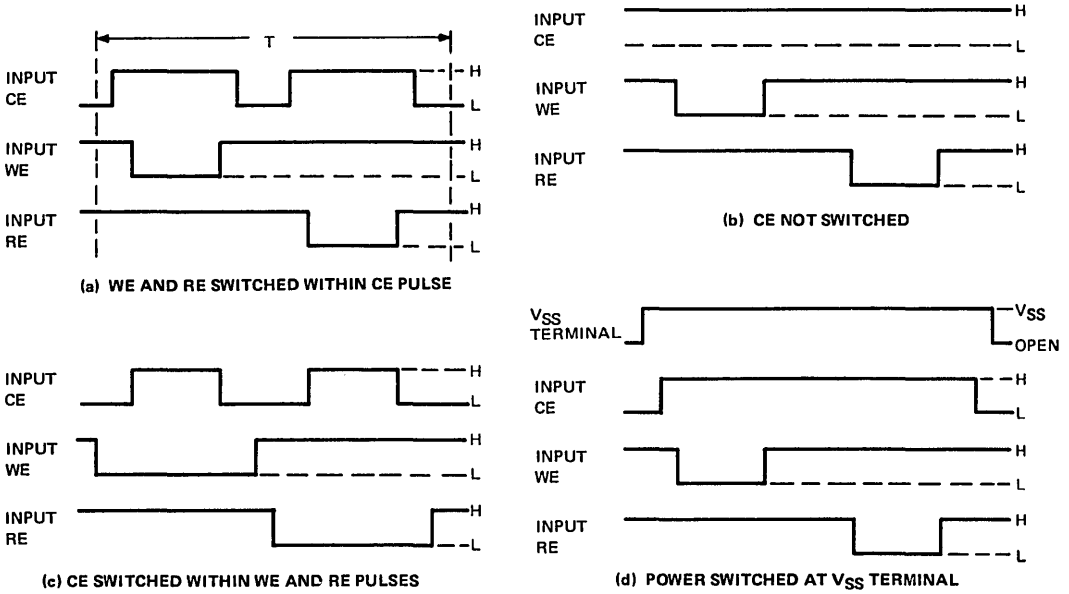

FIGURE 33—TYPICAL OPERATING INPUT VOLTAGE WAVEFORMS FOR SN75370

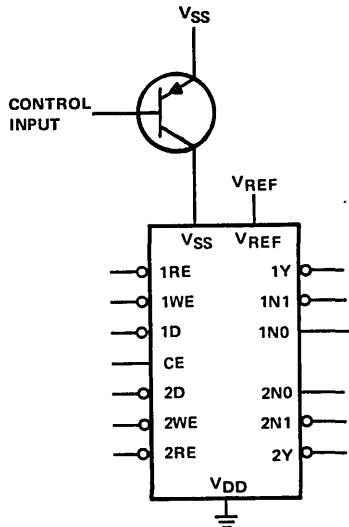

FIGURE 34—SWITCHING POWER TO V<sub>SS</sub> TERMINAL OF SN75370 USING P-N-P TRANSISTOR

# TYPE SN75370

## DUAL-CHANNEL INTERFACE TO MOS MEMORIES

---

### THERMAL INFORMATION

Power generated by the device depends on the mode of operation and the supply voltages used. Under some conditions, the SN75370 may generate sufficient instantaneous power to exceed, on average, the rated continuous power dissipation capability of the package. Appropriate duty-cycling of high-power conditions must be used to keep average power generated by the SN75370 within ratings.

Figure 33 shows typical methods to lower average power dissipation by pulsing the CE, WE, and RE inputs. Highest power occurs when both channels are in the write mode. Usually the write mode must be duty-cycled to reduce average power. Figure 33 (d) and Figure 34 demonstrate the use of a discrete P-N-P transistor to switch power to the V<sub>SS</sub> terminal of the SN75370 to minimize average power. In addition, forced-air cooling or heat-sinking techniques may be used to increase the dissipation capability of the SN75370.

The following example illustrates a method to calculate average d-c supply power for the SN75370. The typical average power over a period T will be calculated using Figure 33(a). Assume both channels are operating identically, except in read mode when one channel is reading a 1 and the other channel is reading a 0. Let V<sub>SS</sub> = 20 V, V<sub>REF</sub> = 7 V and T<sub>A</sub> = 25°C. The subscripts W, R, SB, and D refer to write, read, standby, and disabled, respectively.

$$P_{AV} = \frac{t_W P_W + t_R P_R + t_{SB} P_{SB} + t_D P_D}{T}$$

$$T = t_W + t_R + t_{SB} + t_D$$

Typical power for each mode is stated in the electrical characteristics table. This example uses duty cycles (t/T) estimated from Figure 33(a). These values are then substituted in order:

$$P_{AV} = (0.25) (910) + (0.25) \left( \frac{560+640}{2} \right) + (0.2) (560) + (0.3) (410)$$

$$P_{AV} = 613 \text{ mW}$$

# INTERFACE CIRCUITS

# TYPE SN75375 QUADRUPLE TTL-TO-MOS/PERIPHERAL DRIVER

BULLETIN NO. DL-S 7712564, JULY 1977

- Versatile Interface Circuit for Use Between TTL and High-Current, High-Voltage Systems
- Capable of Driving High-Capacitance Loads
- VCC2 Supply Voltage Variable over Wide Range to 24 Volts Maximum
- Individual VCC2 Supplies for Each of the Drivers
- TTL- and DTL-Compatible Diode-Clamped Inputs
- Operates from Standard Bipolar and MOS Supply Voltages
- High-Speed Switching
- Transient Overdrive Minimizes Power Dissipation
- Low Standby Power Dissipation

J OR N DUAL-IN-LINE PACKAGE (TOP VIEW)

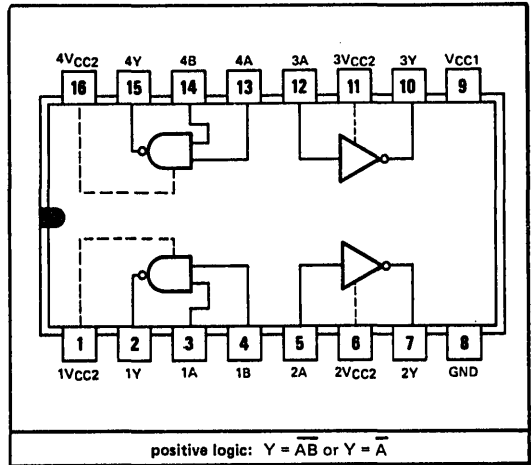

## description

The SN75375 is a monolithic quadruple TTL-to-MOS/peripheral driver and interface circuit. This versatile device accepts standard TTL and DTL input signals and provides high-current and high-voltage output levels suitable for driving MOS circuits and peripheral equipment.

The device features individual VCC2 supplies for each of the drivers. The individual VCC2 pins allow for individual adjustment of high-level output voltage to match various load conditions. The circuit performance is similar to that of the SN75365.

Typical applications include data line transceivers, quad relay drivers, TTL-to-MOS converters, and sink or source drivers for LED's, LCD's, and vacuum fluorescent drivers.

The SN75375 is characterized for operation from 0°C to 70°C.

## schematic (each driver)

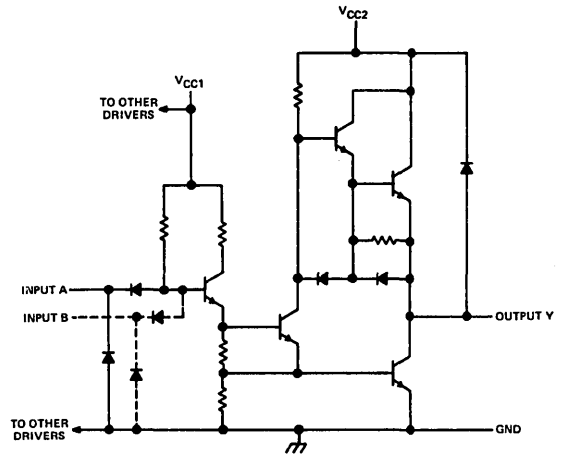

# TYPE SN75375

## QUADRUPLE TTL-TO-MOS/PERIPHERAL DRIVER

**absolute maximum ratings over operating free-air temperature range (unless otherwise noted)**

Supply voltage range of $V_{CC1}$ (see Note 1)	−0.5 V to 7 V
Supply voltage range of $V_{CC2}$	−0.5 V to 25 V
Input voltage	5.5 V
Inter-input voltage (see Note 2)	5.5 V
Output current	150 mA
Continuous total dissipation at (or below) 25°C free-air temperature (see Note 3):	J package 1025 mW
	N package 1150 mW
Operating free-air temperature range	0°C to 70°C
Storage temperature range	−65°C to 150°C
Lead temperature 1/16 inch from case for 60 seconds: J package	300°C
Lead temperature 1/16 inch from case for 10 seconds: N package	260°C

- NOTES: 1. Voltage values are with respect to network ground terminal unless otherwise noted.  
 2. This rating applies between the two inputs of either one of the gates.  
 3. For operation above 25°C free-air temperature, refer to Dissipation Derating Curves in the Thermal Information Section, which starts on page 2-1. In the J package, SN75375 chips are glass-mounted.

7

**recommended operating conditions**

	MIN	NOM	MAX	UNIT
Supply Voltage, $V_{CC1}$	4.75	5	5.25	V
Supply Voltage, $V_{CC2}$	4.75	20	24	V
Operating free-air temperature, $T_A$	0		70	°C



# TYPE SN75375

## QUADRUPLE TTL-TO-MOS/PERIPHERAL DRIVER

electrical characteristics over recommended ranges of  $V_{CC1}$ ,  $V_{CC2}$ , and operating free-air temperature (unless otherwise noted)

PARAMETER	TEST CONDITIONS	MIN	TYP <sup>†</sup>	MAX	UNIT
$V_{IH}$ High-level input voltage			2		V
$V_{IL}$ Low-level input voltage				0.8	V
$V_{IK}$ Input clamp voltage	$I_I = -12$ mA			-1.5	V
$V_{OH}$ High-level output voltage	$V_{IL} = 0.8$ V, $I_{OH} = -50$ $\mu$ A	$V_{CC2}-1$	$V_{CC2}-0.7$		V
	$V_{IL} = 0.8$ V, $I_{OH} = -10$ mA	$V_{CC2}-2.3$	$V_{CC2}-1.8$		
$V_{OL}$ Low-level output voltage	$V_{IH} = 2$ V, $I_{OL} = 1$ mA		0.15	0.3	V
	$V_{IH} = 2$ V, $I_{OL} = 30$ mA		0.3	0.5	
$V_{OK}$ Output clamp voltage	$V_I = 0$ V, $I_{OH} = 20$ mA			$V_{CC2}+1.5$	V
$I_I$ Input current at maximum input voltage	$V_I = 5.5$ V			1	mA
$I_{IH}$ High-level input current	$V_I = 2.4$ V			40	$\mu$ A
$I_{IL}$ Low-level input current	$V_I = 0.4$ V		-1	-1.6	mA
$I_{CC1(H)}$ Supply current from $V_{CC1}$ , all outputs high	$V_{CC1} = 5.25$ V, $V_{CC2} = 24$ V, All inputs at 0 V, No load		4	8	mA
$I_{CC2(H)}$ Supply current from $V_{CC2}$ , all 4 drivers, all outputs high				0.5	
$I_{CC1(L)}$ Supply current from $V_{CC1}$ , all outputs low	$V_{CC1} = 5.25$ V, $V_{CC2} = 24$ V, All inputs at 5 V, No load		31	47	mA
$I_{CC2(L)}$ Supply current from $V_{CC2}$ , all 4 drivers, all outputs low			14	24	
$I_{CC2(S)}$ Supply current from $V_{CC2}$ , all 4 drivers, standby condition	$V_{CC1} = 0$ V, $V_{CC2} = 24$ V, All inputs at 5 V, No load			0.5	mA

<sup>†</sup>All typical values are at  $V_{CC1} = 5$  V,  $V_{CC2} = 20$  V, and  $T_A = 25^\circ$  C.

7

switching characteristics,  $V_{CC1} = 5$  V,  $V_{CC2} = 20$  V,  $T_A = 25^\circ$  C

PARAMETER	TEST CONDITIONS	MIN	TYP	MAX	UNIT	
$t_{DLH}$ Delay time, low-to-high-level output	$C_L = 200$ pF, $R_D = 24$ $\Omega$ , See Figure 1		18	27	ns	
$t_{DHL}$ Delay time, high-to-low-level output			14	21	ns	
$t_{TLH}$ Transition time, low-to-high-level output				18	27	ns
$t_{THL}$ Transition time, high-to-low-level output				21	33	ns
$t_{PLH}$ Propagation delay time, low-to-high-level output			10	36	54	ns
$t_{PHL}$ Propagation delay time, high-to-low-level output			10	34	54	ns

# TYPE SN75375 QUADRUPLE TTL-TO-MOS/PERIPHERAL DRIVER

## PARAMETER MEASUREMENT INFORMATION

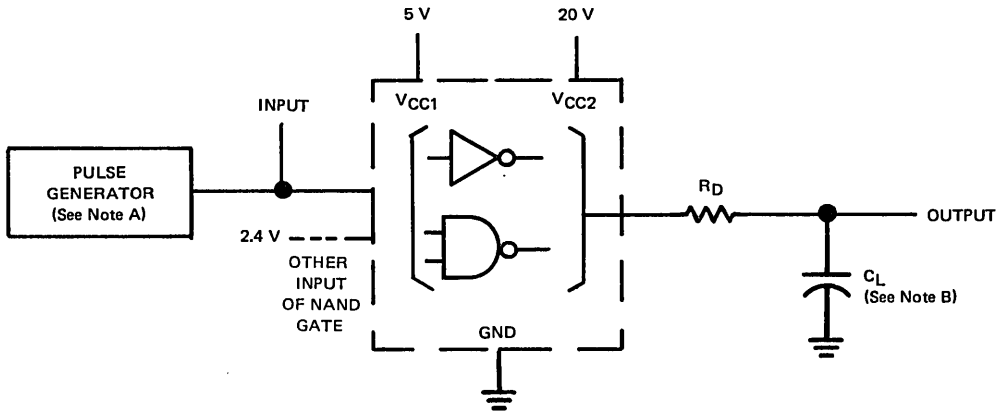

## TEST CIRCUIT

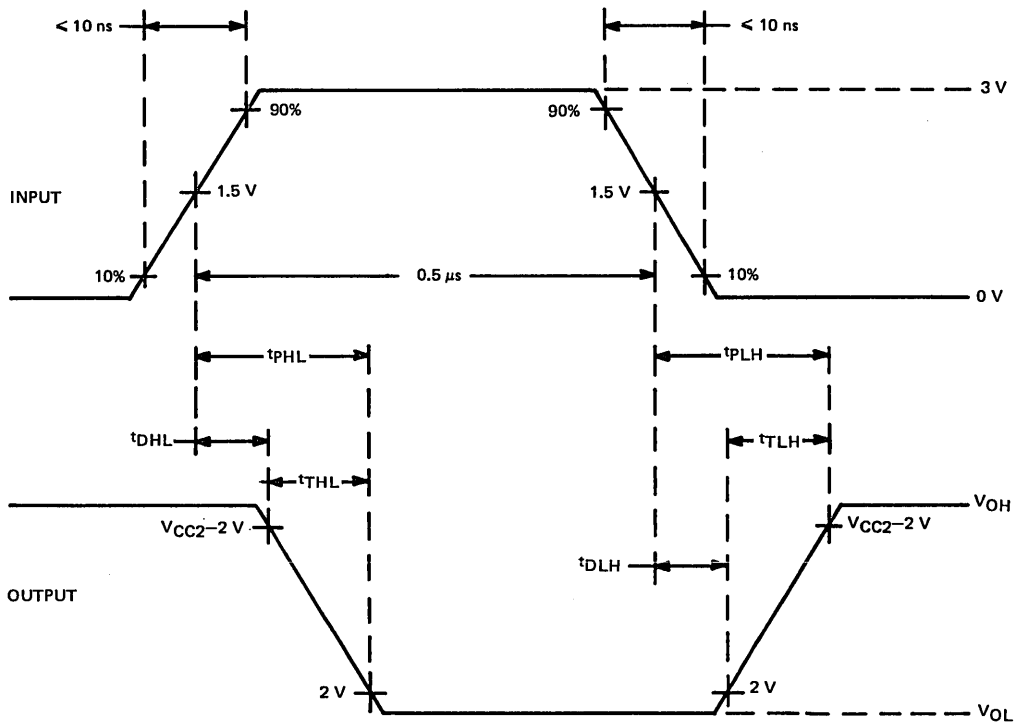

## VOLTAGE WAVEFORMS

- NOTES: A. The pulse generator has the following characteristics: PRR = 1 MHz,  $Z_{out} \approx 50\ \Omega$ .  
B.  $C_L$  includes probe and jig capacitance.

FIGURE 1—SWITCHING TIMES, EACH DRIVER

# Memory Drivers

## MEMORY DRIVERS

• TTL-COMPATIBLE INPUTS

• CORE MEMORY APPLICATIONS

DESCRIPTION	MAXIMUM OUTPUT CURRENT	t <sub>PD</sub> <sup>†</sup> TYPICAL	POWER SUPPLIES	DEVICE TYPE FOR TEMPERATURE RANGE		PACKAGE TYPE	ADDITIONAL FEATURES	PAGE NO.
				-55°C TO 125°C	0°C TO 70°C			
DUAL SINK/SOURCE MEMORY DRIVERS	400 mA	75 ns	V <sub>CC</sub> = 14 V		SN75324	J,N	<ul style="list-style-type: none"> <li>Internal decoding and timing circuitry</li> <li>Output short-circuit protection</li> <li>Source output terminals swing between 14 V and ground</li> </ul>	8-3
	600 mA	35 ns	V <sub>CC1</sub> = 5 V, V <sub>CC2</sub> variable to 24 V	SN55325	SN75325	J J,N	<ul style="list-style-type: none"> <li>Also used for high-voltage, high-current driver applications</li> <li>Output transient voltage protection</li> <li>Source output terminals swing between V<sub>CC2</sub> and ground</li> </ul>	8-10
QUADRUPLE MEMORY DRIVERS	600 mA	35 ns	V <sub>CC1</sub> = 5 V, V <sub>CC2</sub> variable to 24 V	SN55327	SN75327	J J,N	<ul style="list-style-type: none"> <li>Also used for high speed magnetic memory applications</li> <li>Output transient voltage protection</li> <li>Output capable of swinging between V<sub>CC2</sub> and ground</li> </ul>	8-25
		40 ns	V <sub>CC1</sub> = 5 V, V <sub>CC2</sub> variable to 24 V		SN75328 SN75330	J,N	<ul style="list-style-type: none"> <li>Also used for bubble memory applications</li> <li>Output transient voltage protection</li> <li>Output capable of swinging between V<sub>CC2</sub> and ground</li> <li>Uncommitted collectors and emitters</li> <li>Common external base drive control (SN75238)</li> <li>Individual external base drive control (SN75330)</li> </ul>	8-31
QUADRUPLE SINK MEMORY DRIVER	600 mA	30 ns	V <sub>CC</sub> = 5 V	SN55326	SN75326	J J,N	<ul style="list-style-type: none"> <li>Also used for high-voltage, high-current driver applications</li> <li>Output transient voltage protection</li> <li>24 V output capability</li> </ul>	8-25
EIGHT-CHANNEL MEMORY DRIVER	350 mA	85 ns	V <sub>CC1</sub> = 5 V, V <sub>CC2</sub> = 12 V	SN55329		RA	<ul style="list-style-type: none"> <li>Bipolar output currents controlled to within 5%</li> <li>3-state outputs</li> <li>Internal power control — does not require power supply sequencing</li> <li>Contains 3-line to 8-line decoder</li> <li>24-pin ceramic flat package</li> <li>Temperature range: -55°C to 110°C</li> </ul>	See Note 1

<sup>†</sup>t<sub>PD</sub> = Propagation Delay Time

NOTE 1: For additional information, contact your nearest TI field sales office.

# INTERFACE CIRCUITS

# TYPE SN75324 MEMORY CORE DRIVER WITH DECODE INPUTS

BULLETIN NO. DL-S 7711169, APRIL 1969—REVISED APRIL 1977

## SERIES 75 MEMORY DRIVER

### PERFORMANCE

- Fast Switching Times
- 400-mA Output Capability
- Internal Decoding and Timing Circuitry
- Dual Sink/Source Outputs
- Output Short-Circuit Protection

### EASE OF DESIGN

- TTL or DTL Compatibility
- Eliminates Transformer Coupling
- Reduces Drive-Line Lengths
- Increases Reliability
- Minimizes External Components

### description

The SN75324 is a monolithic memory driver with decode inputs designed for use with magnetic memories. The device contains two 400-milliampere (source/sink) switch pairs, with decoding capability from four address lines. Two address inputs (B and C) are used for mode selection, i.e., source or sink. The other two address inputs (A and D) are used for switch-pair selection, i.e., output switch-pair Y/Z or W/X respectively.

The sink circuit is composed of an inverting switch with a transistor-transistor-logic (TTL) input. The source circuit is an emitter-follower driven from a TTL input stage.

The SN75324 is characterized for operation from 0°C to 70°C.

FUNCTION TABLE

INPUTS				OUTPUTS						
ADDRESS	TIMING			SINK	SOURCES		SINK			
A	B	C	D	E	F	G	W	X	Y	Z
L	L	H	H	H	H	H	ON	OFF	OFF	OFF
L	H	L	H	H	H	H	OFF	ON	OFF	OFF
H	H	L	L	H	H	H	OFF	OFF	ON	OFF
H	L	H	L	H	H	H	OFF	OFF	OFF	ON
X	X	X	X	L	X	X	OFF	OFF	OFF	OFF
X	X	X	X	X	L	X	OFF	OFF	OFF	OFF
X	X	X	X	X	X	L	OFF	OFF	OFF	OFF

H = high level, L = low level, X = irrelevant

NOTE: Not more than one output is to be on at one time:  
When all timing inputs are high, two of the address inputs must be low.

J CERAMIC DUAL-IN-LINE PACKAGE (TOP VIEW)

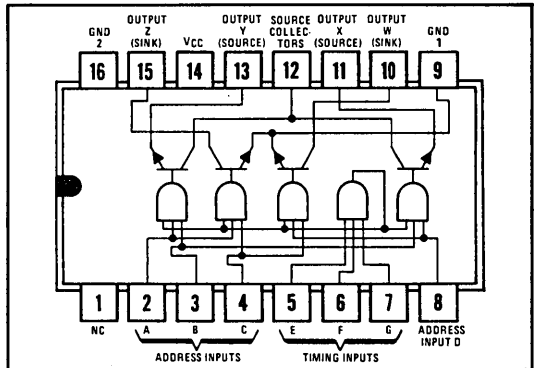

N PLASTIC DUAL-IN-LINE PACKAGE (TOP VIEW)

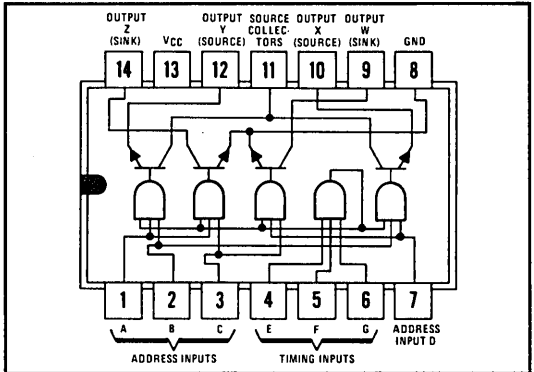

NC—No internal connection

GND 1 and GND 2 are to be connected together.

# TYPE SN75324 MEMORY CORE DRIVER WITH DECODE INPUTS

schematic

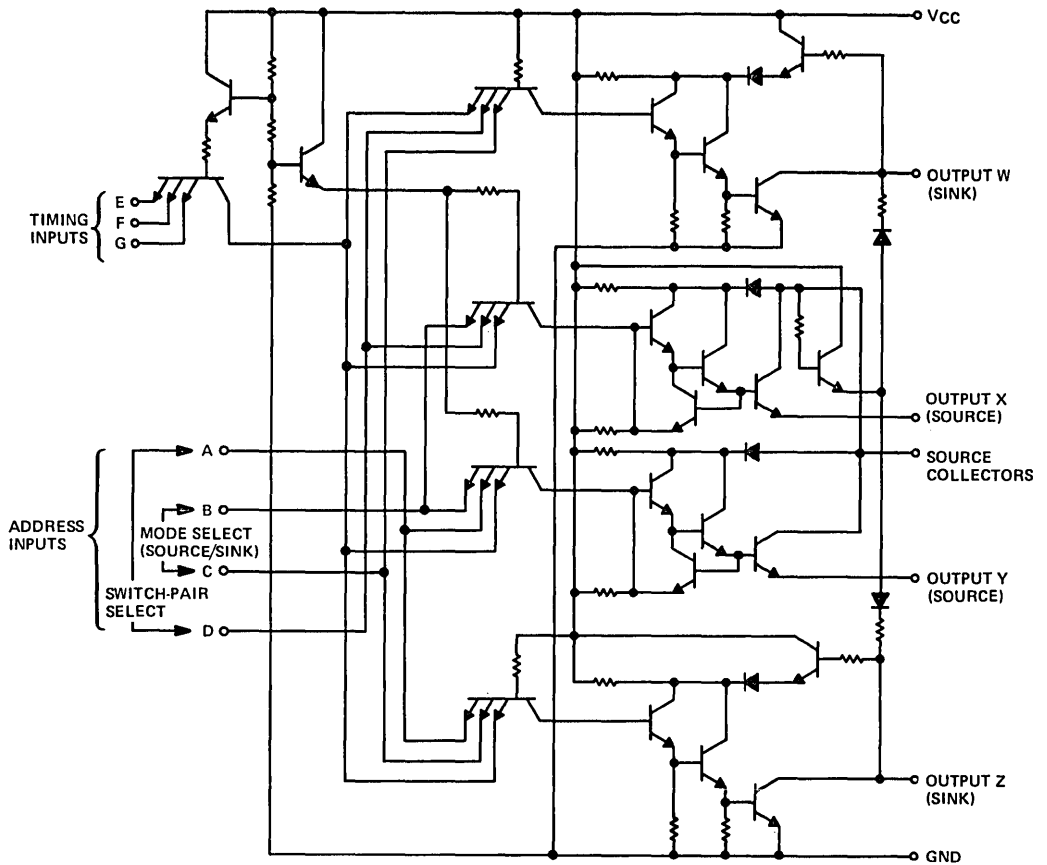

8

# TYPE SN75324

## MEMORY CORE DRIVER WITH DECODE INPUTS

absolute maximum ratings over operating free-air temperature range (unless otherwise noted)

Supply voltage $V_{CC}$ (See Note 1)	17 V
Input voltage (See Note 2)	5.5 V
Operating free-air temperature range	$0^{\circ}\text{C}$ to $70^{\circ}\text{C}$
Continuous total power dissipation at (or below) $25^{\circ}\text{C}$ free-air temperature (See Note 3):	
J package	1375 mW
N package	1150 mW
Storage temperature range	$-65^{\circ}\text{C}$ to $150^{\circ}\text{C}$

- NOTES: 1. Voltage values are with respect to network ground terminal.  
 2. Input signals must be zero or positive with respect to network ground terminal.  
 3. For operation above  $25^{\circ}\text{C}$  free-air temperature, refer to Dissipation Derating Curves in the Thermal Information section, which starts on page 2-1. In the J package, SN75324 chips are alloy-mounted.

electrical characteristics (unless otherwise noted,  $V_{CC} = 14\text{ V}$ ,  $T_A = 0^{\circ}\text{C}$  to  $70^{\circ}\text{C}$ )

PARAMETER		TEST FIGURE	TEST CONDITIONS	MIN	TYP†	MAX	UNIT
$V_{IH}$	High-level input voltage	1		3.5			V
$V_{IL}$	Low-level input voltage	1				0.8	V
$I_{IH}$	High-level input current, address inputs	1	$V_I = 5\text{ V}$			200	$\mu\text{A}$
$I_{IH}$	High-level input current, timing inputs	1	$V_I = 5\text{ V}$			100	$\mu\text{A}$
$I_{IL}$	Low-level input current, address inputs	1	$V_I = 0\text{ V}$			-6	mA
$I_{IL}$	Low-level input current, timing inputs	1	$V_I = 0\text{ V}$			-12	mA
$V_{(sat)}$	Sink saturation voltage	2	$I_{sink} \approx 420\text{ mA}$ , $R_L = 53\ \Omega$		0.75	0.85	V
$V_{(sat)}$	Source saturation voltage	2	$I_{source} \approx -420\text{ mA}$ , $R_L = 47.5\ \Omega$		0.75	0.85	V
$I_{off}$	Output off-state current	1	$V_I = 0\text{ V}$		125	200	$\mu\text{A}$
$I_{CC}$	Supply current, all sources and sinks off	3	$V_I = 0\text{ V}$		12.5	15	mA
$I_{CC}$	Supply current, either sink selected	4			30	42	mA
$I_{CC}$	Supply current, either source selected	4			25	35	mA

†All typical values are at  $T_A = 25^{\circ}\text{C}$

switching characteristics,  $V_{CC} = 14\text{ V}$ ,  $T_A = 25^{\circ}\text{C}$

PARAMETER		TEST FIGURE	TEST CONDITIONS	MIN	TYP	MAX	UNIT
$t_{PLH}$	Propagation delay time, low-to-high-level source output	5	$R_{L1} = 53\ \Omega$ , $R_{L2} = 500\ \Omega$ , $C_L = 20\text{ pF}$			90	ns
$t_{PHL}$	Propagation delay time, high-to-low-level source output	5				50	ns
$t_{PLH}$	Propagation delay time, low-to-high-level sink output	6	$R_L = 53\ \Omega$ , $C_L = 20\text{ pF}$			110	ns
$t_{PHL}$	Propagation delay time, high-to-low-level sink output	6				40	ns
$t_s$	Sink storage time	6				70	ns



# TYPE SN75324 MEMORY CORE DRIVER WITH DECODE INPUTS

## PARAMETER MEASUREMENT INFORMATION

d-c test circuits†

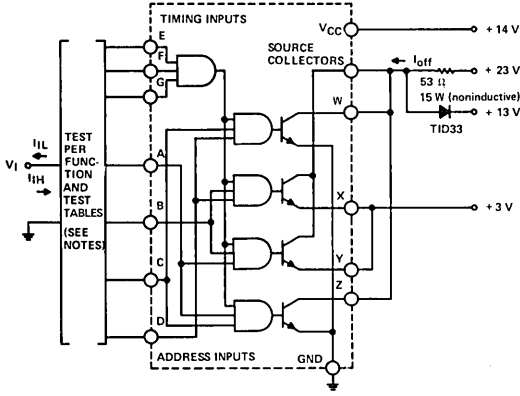

TEST TABLE FOR  $I_{IL}$

APPLY 3.5 V	GROUND	TEST $I_{IL}$
B, C, E, F, and G	A and D	A
B, C, E, F, and G	A and D	D
A, D, E, F, and G	B and C	B
A, D, E, F, and G	B and C	C
A, B, C, D, F, and G	E	E
A, B, C, D, E, and G	F	F
A, B, C, D, E, and F	G	G

- NOTES: 1. Check  $V_{IH}$  and  $V_{IL}$  per Function Table.  
 2. Measure  $I_{IL}$  per Test Table.  
 3. When measuring  $I_{IH}$ , all other inputs are at ground. Each input is tested separately.

FIGURE 1— $V_{IL}$ ,  $V_{IH}$ ,  $I_{IL}$ ,  $I_{IH}$ , and  $I_{off}$

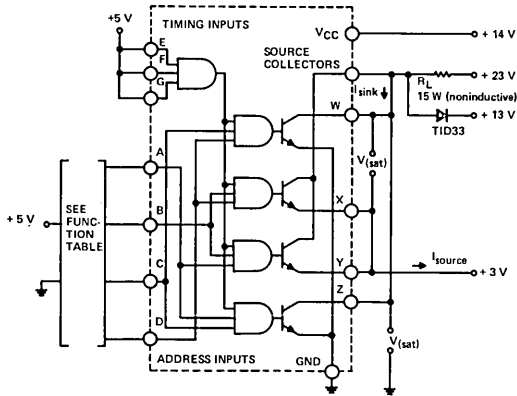

NOTE: This parameter must be using pulse techniques.  $t_w = 500$  ns, duty cycle  $\leq 1\%$ .

FIGURE 2 —  $V_{(sat)}$

† Arrows indicate actual direction of current flow. Current into a terminal is a positive value.



# TYPE SN75324 MEMORY CORE DRIVER WITH DECODE INPUTS

## PARAMETER MEASUREMENT INFORMATION

d-c test circuits † (continued)

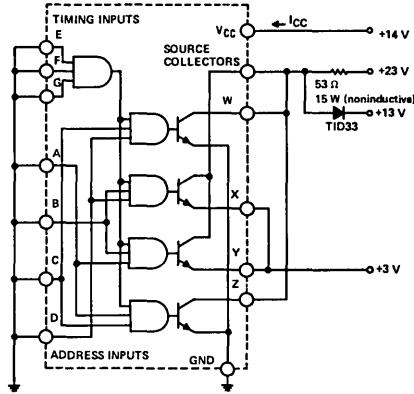
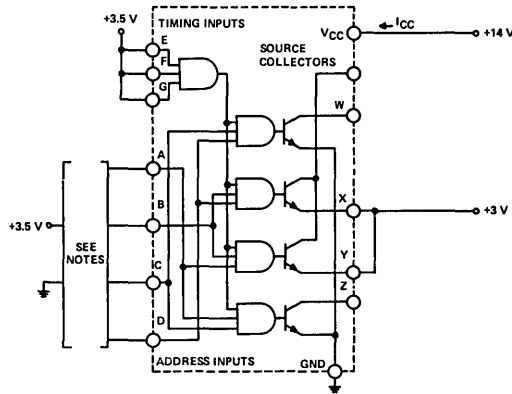

FIGURE 3 -  $I_{CC}$  (ALL OUTPUTS OFF)



- NOTES: 1. Ground A and B, apply 3.5 V to C and D, and measure  $I_{CC}$  (output W is on).  
 2. Ground B and D, apply 3.5 V to A and C, and measure  $I_{CC}$  (output Z is on).  
 3. Ground A and C, apply 3.5 V to B and D, and measure  $I_{CC}$  (output X is on).  
 4. Ground C and D, apply 3.5 V to A and B, and measure  $I_{CC}$  (output Y is on).

FIGURE 4 -  $I_{CC}$  (ONE OUTPUT ON)

† Arrows indicate actual direction of current flow. Current into a terminal is a positive value.

8

# TYPE SN75324 MEMORY CORE DRIVER WITH DECODE INPUTS

## PARAMETER MEASUREMENT INFORMATION

switching characteristics

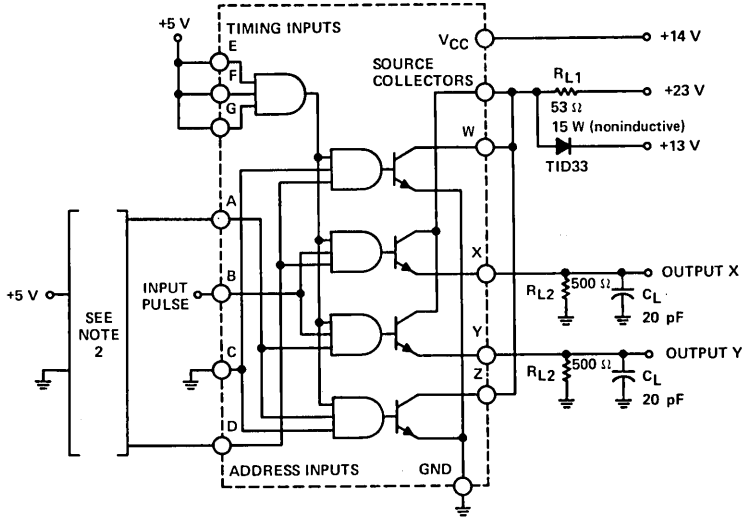

TEST CIRCUIT

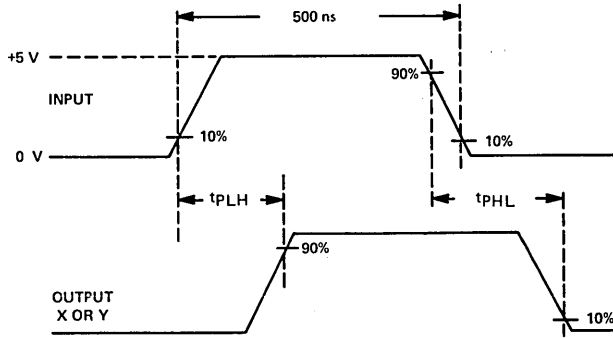

VOLTAGE WAVEFORMS

- NOTES: 1. The input waveform is supplied by a generator with the following characteristics:  $t_r = t_f = 10$  ns, duty cycle  $\leq 1\%$ , and  $Z_{out} \approx 50 \Omega$ .
2. When measuring delay times at output X, apply +5 V to input D, and ground A. When measuring delay times at output Y, apply +5 V to input A, and ground D.
3.  $C_L$  includes probe and jig capacitance.
4. Unless otherwise noted all resistors are 0.5 W.

FIGURE 5 - SOURCE-OUTPUT SWITCHING TIMES

# TYPE SN75324 MEMORY CORE DRIVER WITH DECODE INPUTS

## PARAMETER MEASUREMENT INFORMATION

### switching characteristics

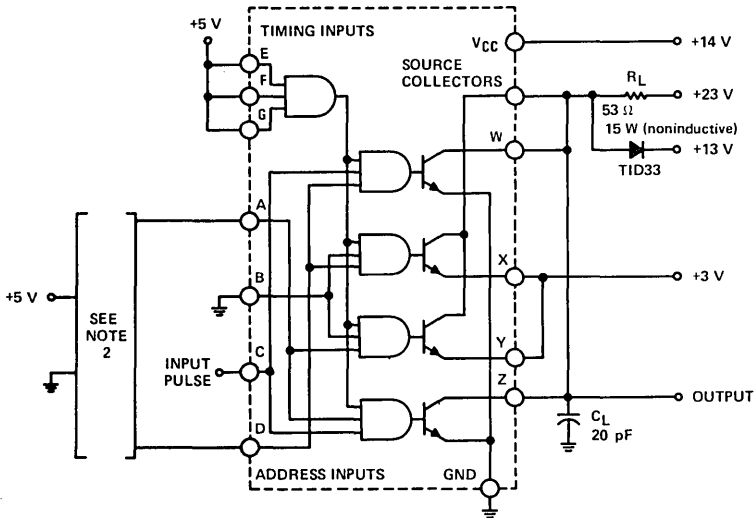

TEST CIRCUIT

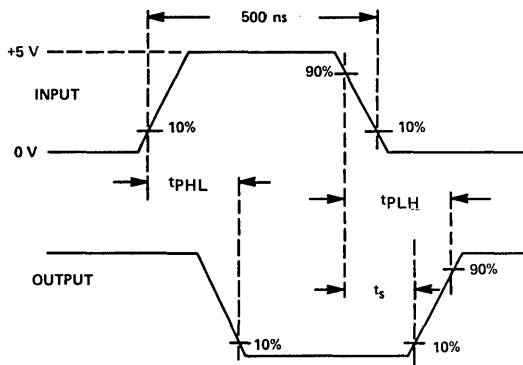

VOLTAGE WAVEFORMS

- NOTES:
1. The input waveform is supplied by a generator with the following characteristics:  $t_r = t_f = 10$  ns, duty cycle  $\leq 1\%$ ,  $Z_{out} \approx 50 \Omega$ .
  2. When measuring delay times at output W, apply +5 V to input D, and ground A. When measuring delay times at output Z, apply +5 V to input A, and ground D.
  3.  $C_L$  includes probe and jig capacitance.

FIGURE 6 — SINK-OUTPUT SWITCHING TIMES

# INTERFACE CIRCUITS

# TYPES SN55325, SN75325 MEMORY CORE DRIVERS

BULLETIN NO. DL-S 7711437, MARCH 1971 — REVISED APRIL 1977

## SERIES 55/75 MEMORY DRIVER featuring

### PERFORMANCE

- 600-mA Output Capability
- Fast Switching Times
- Output Transient-Voltage Protection
- Dual Sink and Dual Source Outputs
- Minimum Time Skew between Address and Output Current Rise
- 24-Volt Output Capability

### EASE OF DESIGN

- Source Base Drive Externally Adjustable
- TTL or DTL Compatibility
- Input Clamping Diodes
- Transformer Coupling Eliminated
- Reliability Increased
- Drive-Line Lengths Reduced
- Use of External Components Minimized

### description

The SN55325 and SN75325 are monolithic integrated circuit memory drivers with logic inputs and are designed for use with magnetic memories.

The devices contain two 600-milliamper source switches and two 600-milliamper sink switches. Source selection is determined by one of two logic inputs, and source turn-on is determined by the source strobe. Likewise, sink selection is determined by one of two logic inputs, and sink turn-on is determined by the sink strobe. This arrangement allows selection of one of the four switches and its subsequent turn-on with minimum time skew of the output current rise.

When  $R_{int}$  and node R are connected together, the amount of base drive available for the source-1 or source-2 output transistor is set internally by a 575-ohm resistor. This method provides adequate base drive for source currents up to 375 mA with a  $V_{CC2}$  voltage of 15 volts or 600 mA with a  $V_{CC2}$  voltage of 24 volts.

When source currents greater than 375 mA are required, it is recommended that a resistor of the appropriate value be connected between  $V_{CC2}$  and node R and  $R_{int}$  must remain open. By using this method the source base current may usually be regulated within  $\pm 5\%$ . An advantage of this method of setting the base drive is that the power dissipated by this resistor is external to the package and allows the integrated circuit to operate at higher source currents for a given junction temperature.

Each sink-output collector has an internal pull-up resistor in parallel with a clamping diode connected to  $V_{CC2}$ . This arrangement provides protection from voltage surges associated with switching inductive loads.

The SN55325 is characterized for operation over the full military temperature range of  $-55^{\circ}\text{C}$  to  $125^{\circ}\text{C}$ ; the SN75325 is characterized for operation from  $0^{\circ}\text{C}$  to  $70^{\circ}\text{C}$ .

J OR N DUAL-IN-LINE PACKAGE  
(TOP VIEW)

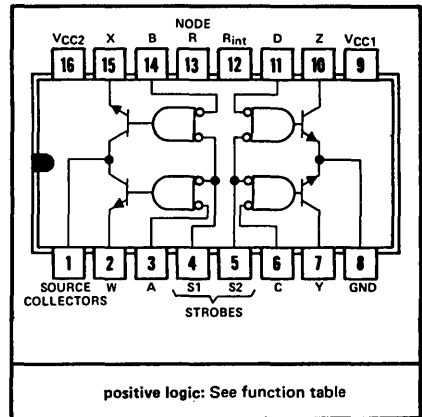

FUNCTION TABLE

ADDRESS INPUTS				STROBE INPUTS		OUTPUTS			
SOURCE	SINK			SOURCE	SINK	SOURCE		SINK	
A	B	C	D	S1	S2	W	X	Y	Z
L	H	X	X	L	H	ON	OFF	OFF	OFF
H	L	X	X	L	H	OFF	ON	OFF	OFF
X	X	L	H	H	L	OFF	OFF	ON	OFF
X	X	H	L	H	L	OFF	OFF	OFF	ON
X	X	X	X	H	H	OFF	OFF	OFF	OFF
H	H	H	H	X	X	OFF	OFF	OFF	OFF

H = high level, L = low level, X = Irrelevant  
NOTE: Not more than one output is to be on at any one time.

# TYPES SN55325, SN75325 MEMORY CORE DRIVERS

REVISED APRIL 1977

## absolute maximum ratings over operating free-air temperature range (unless otherwise noted)

		SN55325	SN75325	UNIT
Supply voltage $V_{CC1}$ (see Note 1)		7	7	V
Supply voltage $V_{CC2}$ (see Note 1)		25	25	V
Input voltage (any address or strobe input)		5.5	5.5	V
Continuous total dissipation at (or below) 25°C free-air temperature (see Note 2)	J package	1375	1375	mW
	N package		1150	
Operating free-air temperature range		-55 to 125	0 to 70	°C
Storage temperature range		-65 to 150	-65 to 150	°C
Lead temperature 1/16 inch from case for 60 seconds		J package	300	°C
Lead temperature 1/16 inch from case for 10 seconds		N package	260	°C

NOTES: 1. Voltage values are with respect to network ground terminal.

2. For operation above 25°C free-air temperature, refer to Dissipation Derating Curves in the Thermal Information section, which starts on page 2-1. In the J package, SN55325 and SN75325 chips are alloy-mounted.

## electrical characteristics over rated operating free-air temperature range (unless otherwise noted)

PARAMETER	TEST FIGURE	TEST CONDITIONS	SN55325		SN75325		UNIT		
			MIN	TYP <sup>‡</sup> MAX	MIN	TYP <sup>‡</sup> MAX			
$V_{IH}$ High-level input voltage	1 & 2		2		2		V		
$V_{IL}$ Low-level input voltage	3 & 4			0.8		0.8	V		
$V_{IK}$ Input clamp voltage	5	$V_{CC1} = 4.5\text{ V}$ , $I_I = -10\text{ mA}$ , $V_{CC2} = 24\text{ V}$ , $T_A = 25^\circ\text{C}$	-1.3	-1.7	-1.3	-1.7	V		
$I_{(off)}$ Source-collectors terminal off-state current	1	$V_{CC1} = 4.5\text{ V}$ , $V_{CC2} = 24\text{ V}$	$T_A = \text{full range } \dagger$ $T_A = 25^\circ\text{C}$		$T_A = \text{full range } \dagger$ $T_A = 25^\circ\text{C}$		$\mu\text{A}$		
$V_{OH}$ High-level sink output voltage	2	$V_{CC1} = 4.5\text{ V}$ , $I_O = 0$	$V_{CC2} = 24\text{ V}$	19	23	19	23	V	
$V_{(sat)}$ Saturation voltage	source outputs	$V_{CC1} = 4.5\text{ V}$ , $V_{CC2} = 15\text{ V}$ , $R_L = 24\ \Omega$ , $I_{(source)} \approx -600\text{ mA}$ §, See Note 3	$T_A = \text{full range } \dagger$	0.9		0.9	V		
			$T_A = 25^\circ\text{C}$	0.43	0.7	0.43		0.75	
	sink outputs		$T_A = \text{full range } \dagger$	0.9		0.9			
			$T_A = 25^\circ\text{C}$	0.43	0.7	0.43		0.75	
$I_I$ Input current at maximum input voltage	address inputs	$V_{CC1} = 5.5\text{ V}$ , $V_I = 5.5\text{ V}$	$V_{CC2} = 24\text{ V}$		1		1	mA	
	strobe inputs				2		2		
$I_{IH}$ High-level input current	address inputs	$V_{CC1} = 5.5\text{ V}$ , $V_I = 2.4\text{ V}$	$V_{CC2} = 24\text{ V}$		3	40	3	40	$\mu\text{A}$
	strobe inputs				6	80	6	80	
$I_{IL}$ Low-level input current	address inputs	$V_{CC1} = 5.5\text{ V}$ , $V_I = 0.4\text{ V}$	$V_{CC2} = 24\text{ V}$		-1	-1.6	-1	-1.6	mA
	strobe inputs				-2	-3.2	-2	-3.2	
$I_{CC(off)}$ Supply current, all sources and sinks off	from $V_{CC1}$	$V_{CC1} = 5.5\text{ V}$ , $T_A = 25^\circ\text{C}$	$V_{CC2} = 24\text{ V}$		14	22	14	22	mA
	from $V_{CC2}$				7.5	20	7.5	20	
$I_{CC1}$ Supply current from $V_{CC1}$ , either sink on	7	$V_{CC1} = 5.5\text{ V}$ , $I_{(sink)} = 50\text{ mA}$ ,	$V_{CC2} = 24\text{ V}$ , $T_A = 25^\circ\text{C}$		55	70	55	70	mA
$I_{CC2}$ Supply current from $V_{CC2}$ , either source on	8	$V_{CC1} = 5.5\text{ V}$ , $I_{(source)} = -50\text{ mA}$ , See Note 3	$V_{CC2} = 24\text{ V}$ , $T_A = 25^\circ\text{C}$		32	50	32	50	mA

<sup>†</sup>Full range for SN55325 is -55°C to 125°C and for SN75325 is 0°C to 70°C.

<sup>‡</sup>All typical values are at  $T_A = 25^\circ\text{C}$ .

<sup>§</sup>Under these conditions, not more than one output is to be on at any one time.

NOTE 3: These parameters must be measured using pulse techniques.  $t_w = 200\ \mu\text{s}$ , duty cycle  $\leq 2\%$ .

# TYPES SN55325, SN75325 MEMORY CORE DRIVERS

switching characteristics,  $V_{CC1} = 5\text{ V}$ ,  $T_A = 25^\circ\text{C}$

PARAMETER†	TO (OUTPUT)	TEST FIGURE	TEST CONDITIONS	MIN	TYP	MAX	UNIT
$t_{PLH}$	Source collectors	9	$V_{CC2} = 15\text{ V}$ , $R_L = 24\ \Omega$ , $C_L = 25\text{ pF}$	35	50	ns	
$t_{PHL}$				35	50		
$t_{TLH}$	Source outputs	10	$V_{CC2} = 20\text{ V}$ , $R_L = 1\text{ k}\Omega$ , $C_L = 25\text{ pF}$	55	7	ns	
$t_{THL}$				7			
$t_{PLH}$	Sink outputs	9	$V_{CC2} = 15\text{ V}$ , $R_L = 24\ \Omega$ , $C_L = 25\text{ pF}$	20	45	ns	
$t_{PHL}$				20	45		
$t_{TLH}$	Sink outputs	9	$V_{CC2} = 15\text{ V}$ , $R_L = 24\ \Omega$ , $C_L = 25\text{ pF}$	7	15	ns	
$t_{THL}$				9	20		
$t_s$	Sink outputs	9	$V_{CC2} = 15\text{ V}$ , $R_L = 24\ \Omega$ , $C_L = 25\text{ pF}$	15	30	ns	

- †  $t_{PLH}$  = propagation delay time, low-to-high-level output
- †  $t_{PHL}$  = propagation delay time, high-to-low-level output
- †  $t_{TLH}$  = transition time, low-to-high-level output
- †  $t_{THL}$  = transition time, high-to-low-level output
- †  $t_s$  = storage time

## schematic

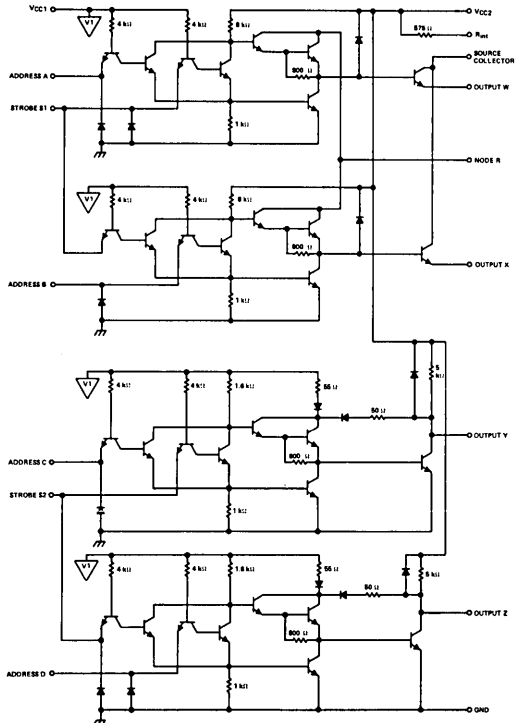

Component values shown are nominal.

$V_{CC1}$  ...  $V_{CC1}$  bus

# TYPES SN55325, SN75325 MEMORY CORE DRIVERS

d-c test circuits†

## PARAMETER MEASUREMENT INFORMATION

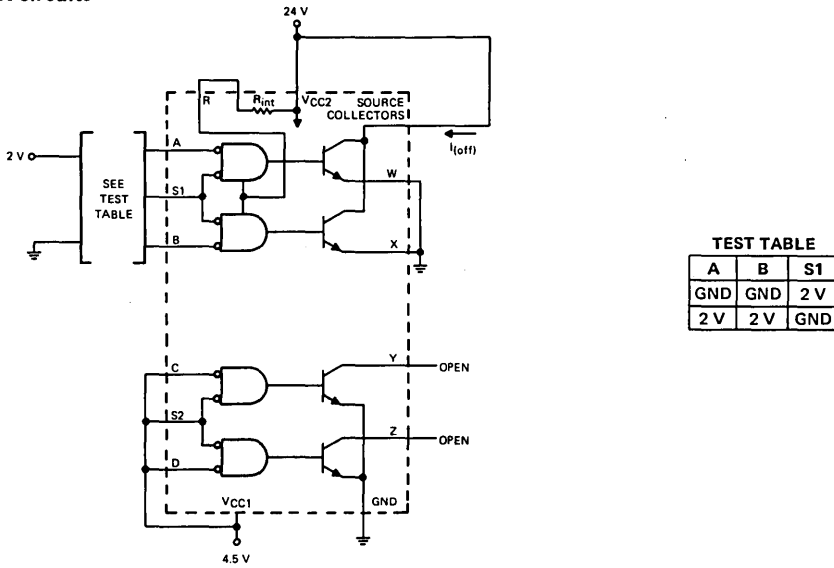

FIGURE 1— $V_{IH}$  AND  $I_{(off)}$

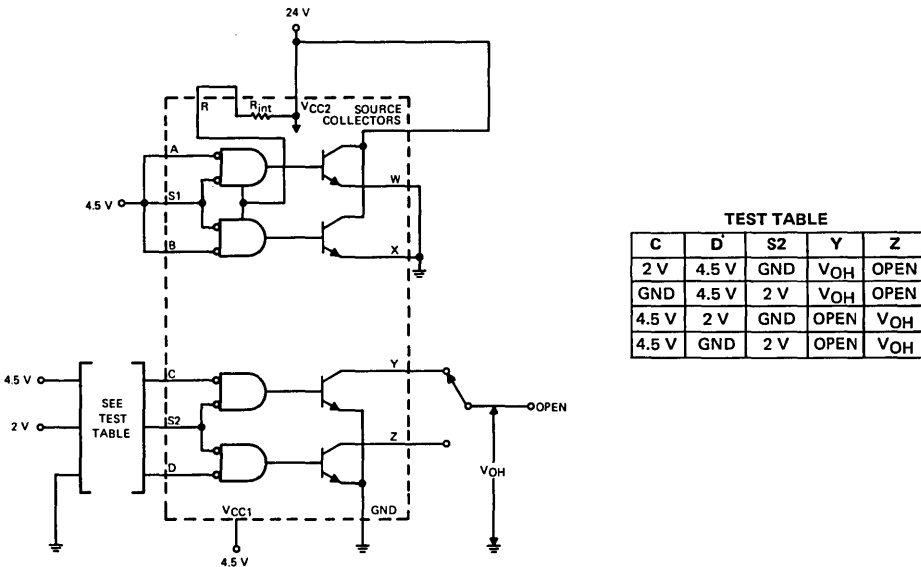

FIGURE 2— $V_{IH}$  AND  $V_{OH}$

† Arrows indicate actual direction of current flow.

# TYPES SN55325, SN75325 MEMORY CORE DRIVERS

## PARAMETER MEASUREMENT INFORMATION

d-c test circuits (continued)<sup>†</sup>

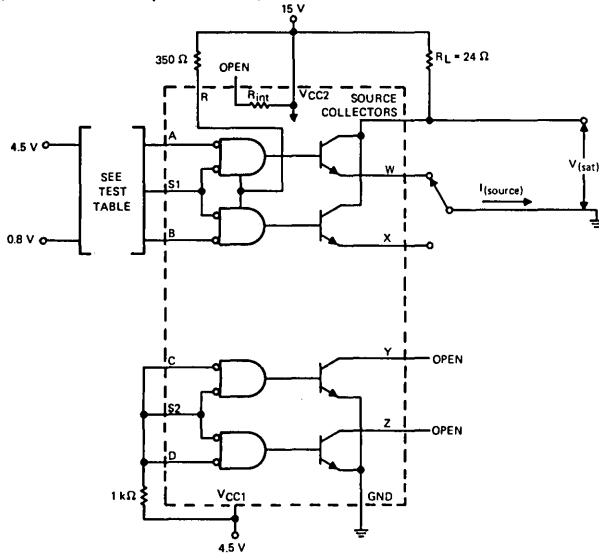

TEST TABLE

A	B	S1	W	X
0.8 V	4.5 V	0.8 V	GND	OPEN
4.5 V	0.8 V	0.8 V	OPEN	GND

NOTE A: These parameters must be measured using pulse techniques.  $t_w = 200 \mu s$ , duty cycle  $\leq 2\%$ .

FIGURE 3— $V_{IL}$  AND SOURCE  $V_{(sat)}$

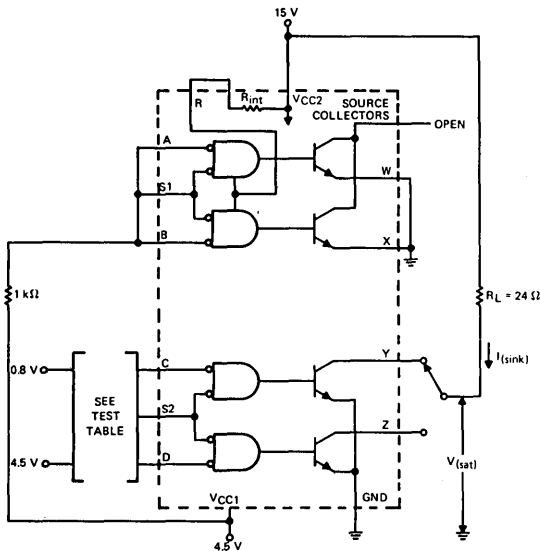

TEST TABLE

C	D	S2	Y	Z
0.8 V	4.5 V	0.8 V	$R_L$	OPEN
4.5 V	0.8 V	0.8 V	OPEN	$R_L$

NOTE A: These parameters must be measured using pulse techniques.  $t_w = 200 \mu s$ , duty cycle  $\leq 2\%$ .

FIGURE 4— $V_{IL}$  AND SINK  $V_{(sat)}$

<sup>†</sup> Arrows indicate actual direction of current flow.



# TYPES SN55325, SN75325 MEMORY CORE DRIVERS

## PARAMETER MEASUREMENT INFORMATION

d-c test circuits (continued)<sup>†</sup>

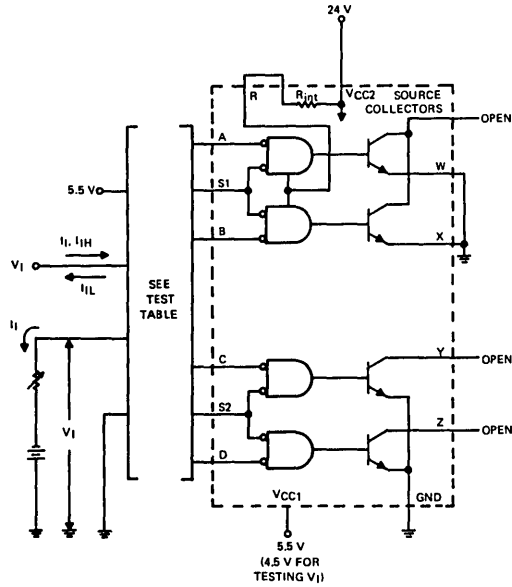

### TEST TABLES

#### $I_i, I_{iH}$

APPLY $V_i = 5.5$ V, MEASURE $I_i$	GROUND	APPLY 5.5 V
APPLY $V_i = 2.4$ V, MEASURE $I_{iH}$		
A	S1	B, C, S2, D
S1	A, B	C, S2, D
B	S1	A, C, S2, D
C	S2	A, S1, B, D
S2	C, D	A, S1, B
D	S2	A, S1, B, C

#### $V_i, I_{iL}$

APPLY $V_i = 0.4$ V, MEASURE $I_{iL}$	APPLY 5.5 V
APPLY $I_i = -10$ mA MEASURE $V_i$	
A	S1, B, C, S2, D
S1	A, B, C, S2, D
B	A, S1, C, S2, D
C	A, S1, B, S2, D
S2	A, S1, B, C, D
D	A, S1, B, C, S2

FIGURE 5— $V_i, I_i, I_{iH}$ , AND  $I_{iL}$

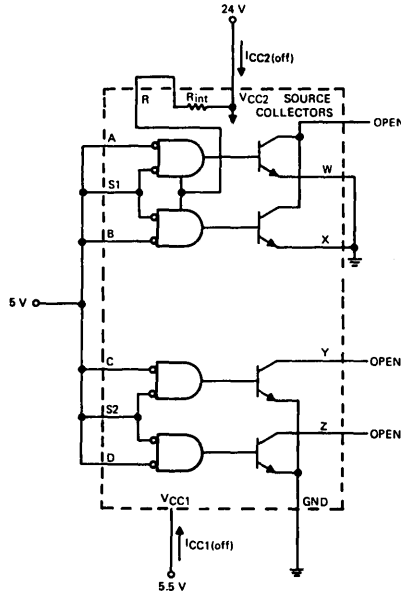

FIGURE 6— $I_{CC1}(\text{off})$  AND  $I_{CC2}(\text{off})$

<sup>†</sup> Arrows indicate actual direction of current flow.

# TYPES SN55325, SN75325 MEMORY CORE DRIVERS

## PARAMETER MEASUREMENT INFORMATION

d-c test circuits (continued)<sup>†</sup>

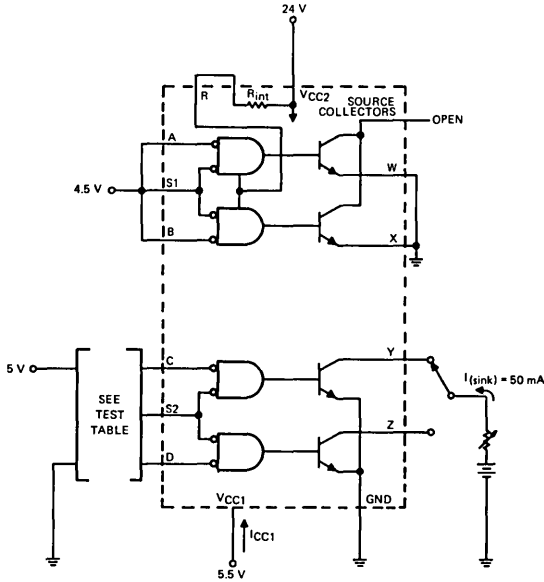

**TEST TABLE**

C	D	S2	Y	Z
GND	5 V	GND	I <sub>(sink)</sub>	OPEN
5 V	GND	GND	OPEN	I <sub>(sink)</sub>

FIGURE 7— $I_{CC1}$ , EITHER SINK ON

8

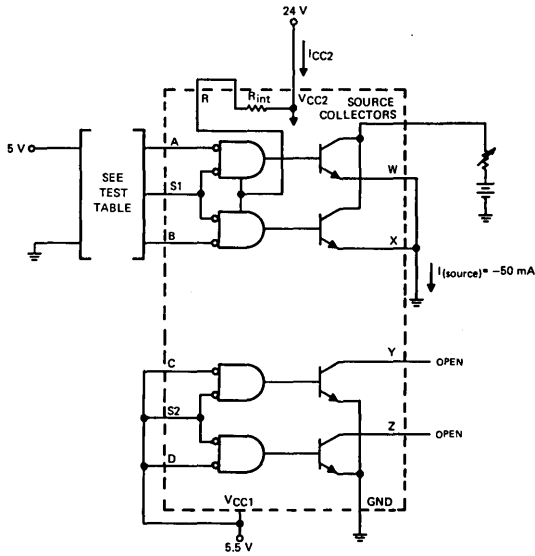

**TEST TABLE**

A	B	S1
GND	5 V	GND
5 V	GND	GND

FIGURE 8— $I_{CC2}$ , EITHER SOURCE ON

<sup>†</sup>Arrows indicate actual direction of current flow.

# TYPES SN55325, SN75325 MEMORY CORE DRIVERS

## PARAMETER MEASUREMENT INFORMATION

switching characteristics

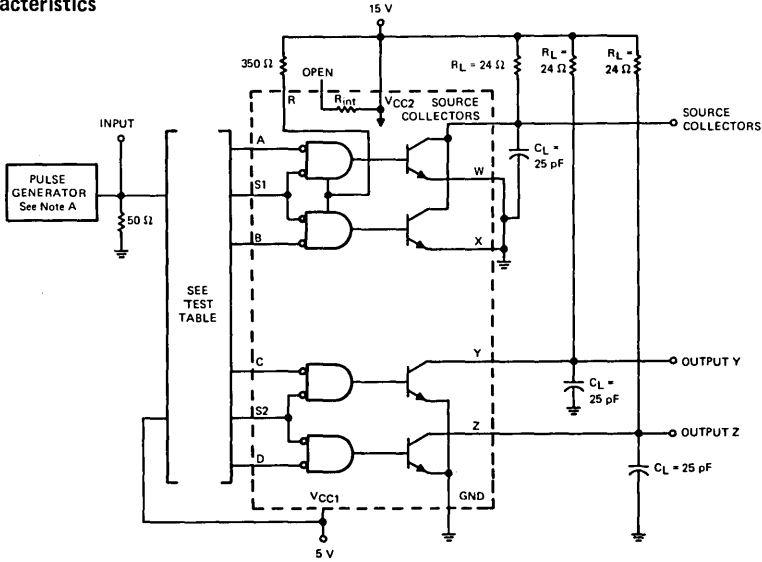

TEST CIRCUIT

TEST TABLE

PARAMETER	OUTPUT UNDER TEST	INPUT	CONNECT TO 5 V
$t_{PLH}$ and $t_{PHL}$	Source collectors	A and S1 B and S1	B, C, D and S2 A, C, D and S2
$t_{PLH}$ , $t_{PHL}$ , $t_{TLH}$ , $t_{THL}$ , and $t_s$	Sink output Y	C and S2	A, B, D and S1
	Sink output Z	D and S2	A, B, C and S1

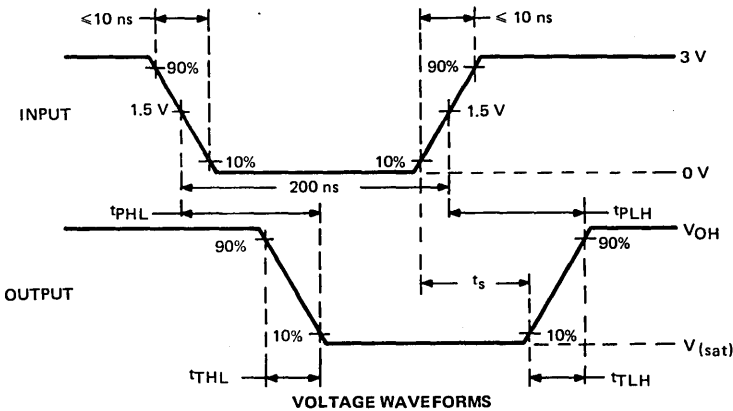

NOTES: A. The pulse generator has the following characteristics:  $Z_{out} = 50 \Omega$ , duty cycle  $< 1\%$ .  
B.  $C_L$  includes probe and jig capacitance.

FIGURE 9—SWITCHING TIMES

8

# TYPES SN55325, SN75325 MEMORY CORE DRIVERS

## PARAMETER MEASUREMENT INFORMATION

switching characteristics

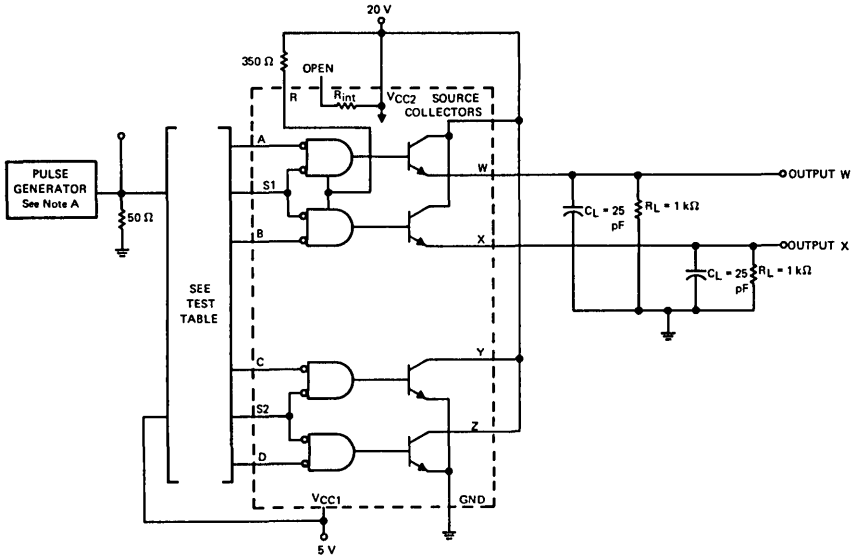

TEST CIRCUIT

TEST TABLE

PARAMETER	OUTPUT UNDER TEST	INPUT	CONNECT TO 5 V
$t_{TLH}$ and $t_{THL}$	Source output W	A and S1	B, C, D, and S2
	Source output X	B and S1	A, C, D, and S2

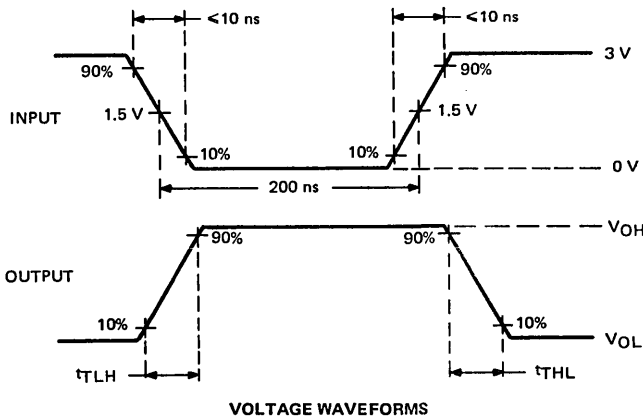

VOLTAGE WAVEFORMS

- NOTES: A. The pulse generator has the following characteristics:  $Z_{out} = 50 \Omega$ , duty cycle  $< 1\%$ .  
B.  $C_L$  includes probe and jig capacitance.

FIGURE 10—TRANSITION TIMES OF SOURCE OUTPUTS

# TYPES SN55325, SN75325 MEMORY CORE DRIVERS

## TYPICAL CHARACTERISTICS

OFF-STATE CURRENT INTO SOURCE COLLECTORS

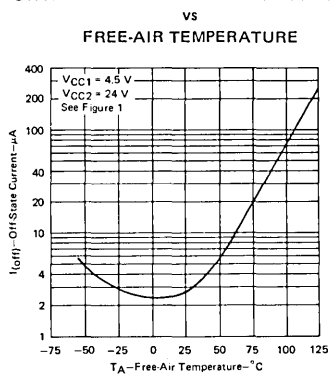

FIGURE 11

HIGH-LEVEL SINK OUTPUT VOLTAGE

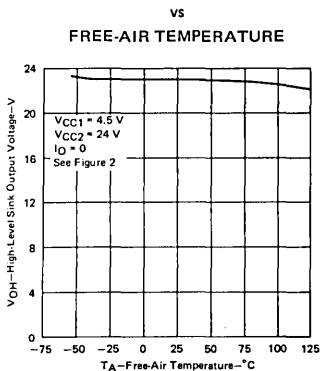

FIGURE 12

SOURCE OR SINK SATURATION VOLTAGE

vs  
SOURCE CURRENT OR SINK CURRENT

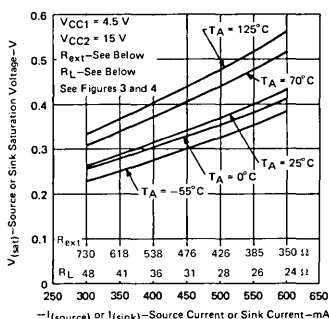

FIGURE 13

SOURCE OR SINK SATURATION VOLTAGE

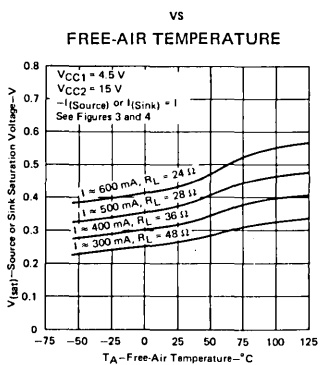

FIGURE 14

SUPPLY CURRENT, ALL SOURCES AND SINKS OFF

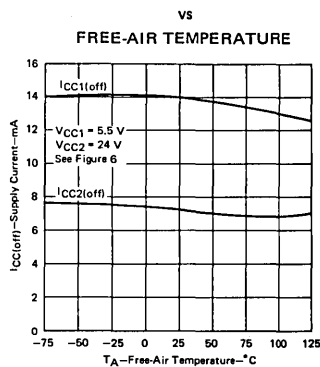

FIGURE 15

8

# TYPES SN55325, SN75325 MEMORY CORE DRIVERS

## TYPICAL APPLICATION DATA

### balanced bipolar logic-line driver

The circuit shown in Figure 16 converts standard TTL logic to bipolar logic. Bipolar logic is primarily used in transmitting data or clock pulses over long lines. This line-driver may be operated from a single 5-volt supply; however, the output drive may be increased by raising the supply voltage to the source collectors. The circuit features a three-state output which is off during the absence of data, thus not dissipating high power. It provides a balanced drive circuit giving maximum noise immunity when used with the proper line receiver. Large drive levels can be used to further increase noise immunity. The circuit is capable of driving twisted-pair lines of several thousand feet in length or low-impedance coaxial lines.

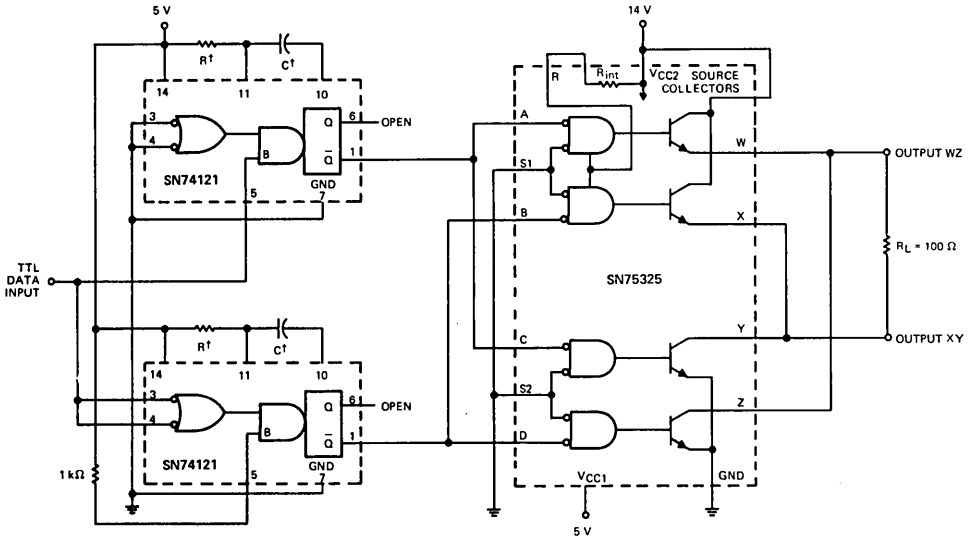

TEST CIRCUIT

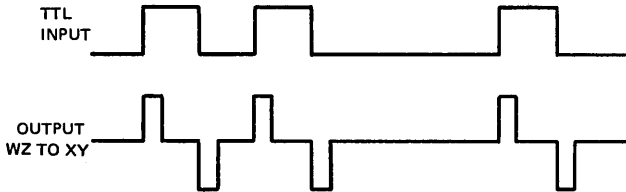

VOLTAGE WAVEFORMS

† R and C are adjusted to give the desired bipolar output pulse width.

FIGURE 16—BALANCED BIPOLAR LOGIC—LINE DRIVER

# TYPES SN55325, SN75325 MEMORY CORE DRIVERS

## TYPICAL APPLICATION DATA

In memory-drive applications the SN75325 (or for full-temperature operation, the SN55325) can be connected in any of several ways. Typically, however, sources and sinks are arranged in pairs from which many drive-lines branch off as shown in Figure 17. Here each drive-line is served by a unique combination of two source/sink pairs so that a selection matrix is formed. To select drive-line 13, SN74154 No. 1 must be set to 3 (with mode select high), enabling source X of SN75325 No. 2 to drive lines 12 through 15, and SN74154 No. 2 must be set to 2, providing a sink at Y of SN75325 No. 4 for drive-line 13 only. Alternatively, to drive current in drive-line 13 in the opposite direction, only the mode-select voltage would be changed from high to low. The size of such a matrix is limited only by the number of drive-lines that a source/sink pair can serve. This number in turn depends on the capacitive and inductive load that each drive-line of the particular system imposes on the driver. A 256-drive-line selection matrix is shown in Figure 18. These 256 drive-lines are sufficient to serve  $(256/2)^2 = 16,384$  individual cores.

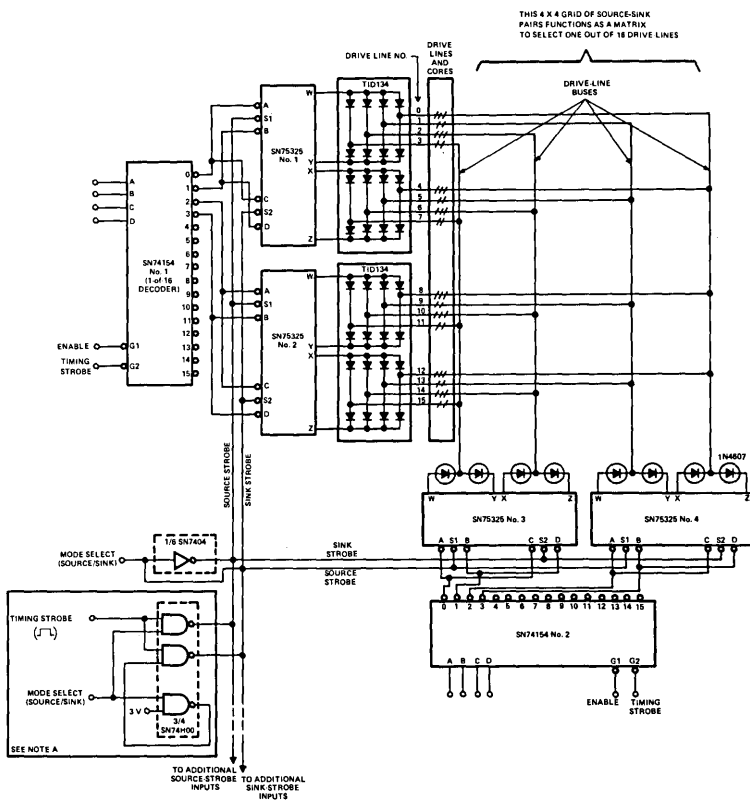

NOTE A: This optional mode-select and timing-strobe technique can be used in place of the SN7440 mode-select and SN74154 timing-strobe when minimum time skew is desired.

FIGURE 17—SN75325 USED AS A MEMORY DRIVER  
TO SELECT ONE OF SIXTEEN DRIVE LINES

**TYPES SN55325, SN75325  
MEMORY CORE DRIVERS**

**TYPICAL APPLICATION DATA**

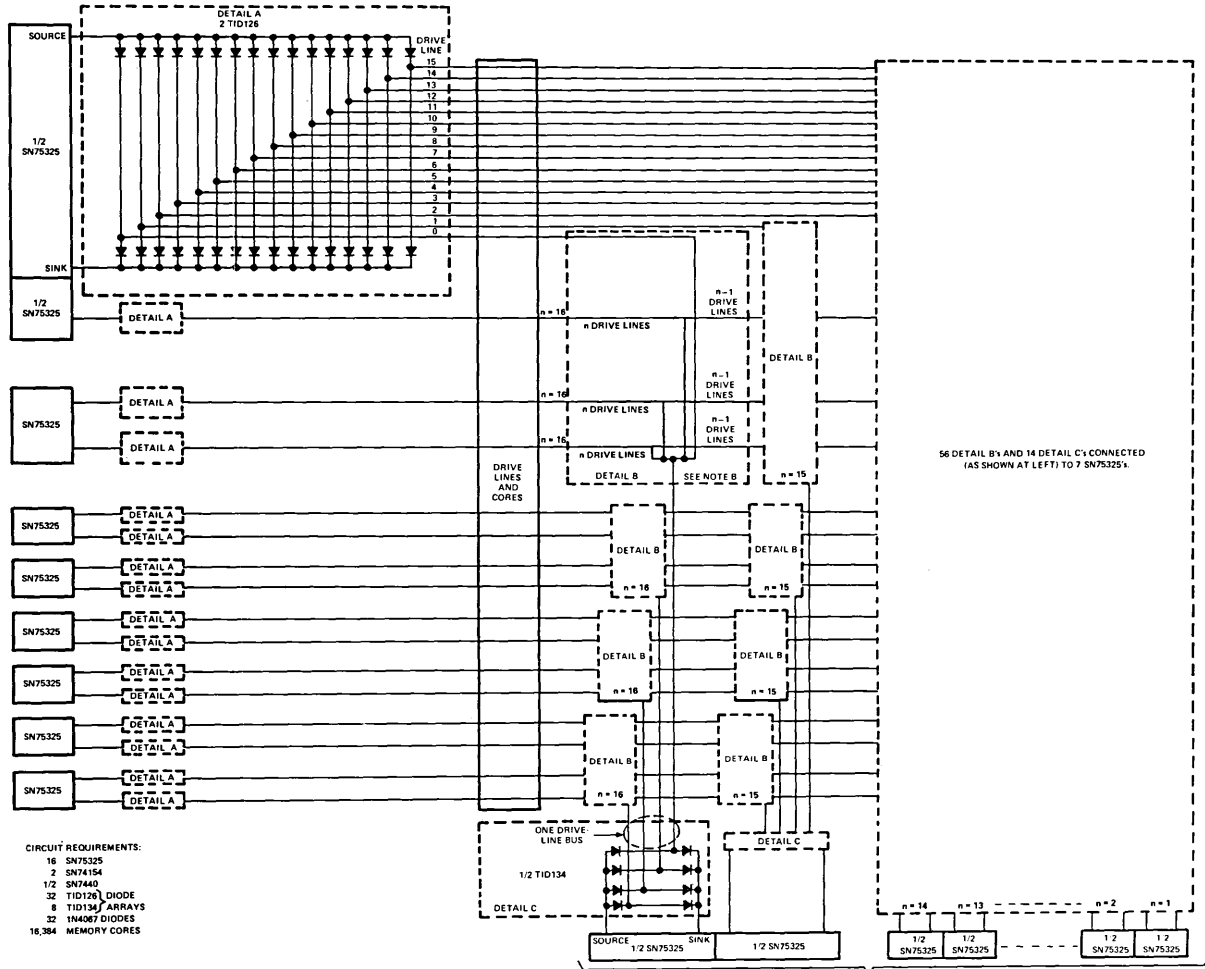

- CIRCUIT REQUIREMENTS:**
- 16 SN75325
  - 2 SN74154
  - 1/2 SN7440
  - 32 TI0126 DIODE
  - 8 TI0134 ARRAYS
  - 32 1N4067 DIODES
  - 16,384 MEMORY CORES

NOTES: A. Outputs from one SN74154 decoder are connected to each SN75325 as shown in Figure 17. Source strobe and sink strobe from an SN7440 are connected to each SN75325 as shown in Figure 17.

B. The division of the drive-line bus into four segments reduces the capacitive load on the SN75325 driver.

**FIGURE 18—SN75325 SERVING 256 DRIVE LINES IN A MAGNETIC MEMORY**



# TYPES SN55325, SN75325 MEMORY CORE DRIVERS

---

## TYPICAL APPLICATION DATA

### external resistor calculation

A typical magnetic-memory word-drive requirement is shown in Figure 19. A source-output transistor of one SN75325 delivers load current ( $I_L$ ). The sink-output transistor of another SN75325 sinks this current.

The value of the external pull-up resistor ( $R_{ext}$ ) for a particular memory application may be determined using the following equation:

$$R_{ext} = \frac{16 [V_{CC2(min)} - V_S - 2.2]}{I_L - 1.6 [V_{CC2(min)} - V_S - 2.9]} \quad (\text{Equation 1})$$

where:  $R_{ext}$  is in  $k\Omega$ ,  
 $V_{CC2(min)}$  is the lowest expected value of  $V_{CC2}$  in volts,  
 $V_S$  is the source output voltage in volts with respect to ground,  
 $I_L$  is in mA.

The power dissipated in resistor  $R_{ext}$  during the load current pulse duration is calculated using Equation 2,

$$P_{R_{ext}} \approx \frac{I_L}{16} [V_{CC2(min)} - V_S - 2] \quad (\text{Equation 2})$$

where:  $P_{R_{ext}}$  is in mW.

After solving for  $R_{ext}$ , the magnitude of the source collector current ( $I_{CS}$ ) is determined from Equation 3,

$$I_{CS} \approx 0.94 I_L \quad (\text{Equation 3})$$

where:  $I_{CS}$  is in mA.

As an example, let  $V_{CC2(min)} = 20$  V and  $V_L = 3$  V while  $I_L$  of 500 mA flows.

Using Equation 1,

$$R_{ext} = \frac{16 (20 - 3 - 2.2)}{500 - 1.6 (20 - 3 - 2.9)} = 0.5 \text{ k}\Omega$$

and from Equation 2,

$$P_{R_{ext}} \approx \frac{500}{16} [20 - 3 - 2] \approx 470 \text{ mW}$$

The amount of the memory system current source ( $I_{CS}$ ) from Equation 3 is:

$$I_{CS} \approx 0.94 (500) \approx 470 \text{ mA}$$

In this example the regulated source-output transistor base current through the external pull-up resistor ( $R_{ext}$ ) and the source gate is approximately 30 mA. This current and  $I_{CS}$  comprise  $I_L$ .

# TYPES SN55325, SN75325 MEMORY CORE DRIVERS

## TYPICAL APPLICATION DATA

external resistor calculation (continued)

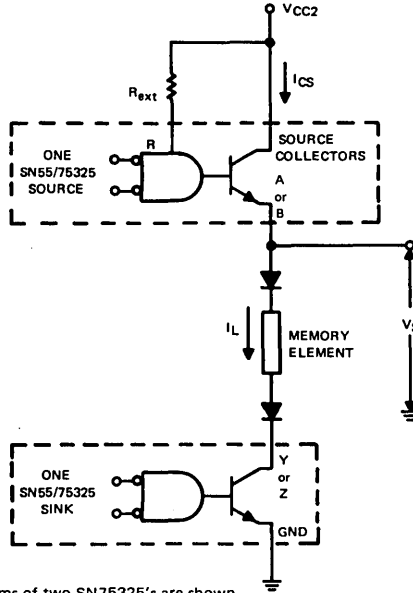

NOTES: A. For clarity, partial logic diagrams of two SN75325's are shown.  
B. Source and sink shown are in different packages.

FIGURE 19

# INTERFACE CIRCUITS

# TYPES SN55326, SN55327, SN75326, SN75327 MEMORY CORE DRIVERS

BULLETIN NO. DL-S 7712063, SEPTEMBER 1973 — REVISED APRIL 1977

## SERIES 55/75 MEMORY DRIVERS featuring

### SN55326, SN75326 PERFORMANCE

- Quad Positive-OR Sink Memory Drivers
- 600-mA Output Current Sink Capability
- 24-V Output Capability
- Clamp Voltage Variable to 24 V

### SN55327, SN75327 PERFORMANCE

- Quad Memory Switches
- 600-mA Output Current Capability
- VCC2 Drive Voltage Variable to 24 V
- Output Capable of Swinging Between VCC2 and Ground

### EASE OF DESIGN

- High-Repetition-Rate Driver Compatible with High-Speed Magnetic Memories
- Inputs Compatible with TTL Decoders
- Minimum Time Skew between Strobe and Output-Current Rise
- Pulse-Transformer Coupling Eliminated
- Drive-Line Lengths Reduced

### SN55326, SN75326

J OR N DUAL-IN-LINE PACKAGE  
(TOP VIEW)

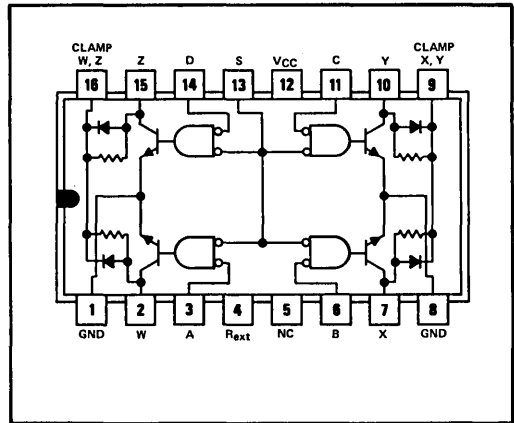

NC—No internal connection

### SN55327, SN75327

J OR N DUAL-IN-LINE PACKAGE  
(TOP VIEW)

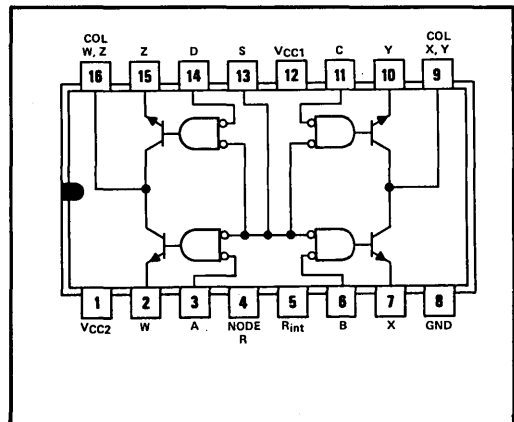

### description

The SN55326, SN55327, SN75326, and SN75327 are monolithic integrated circuit quadruple memory drivers. These devices accept standard TTL decoder input signals and provide high-current and high-voltage output levels suitable for driving magnetic memory elements. Output transistor selection is determined by using one of the four address inputs and the common timing strobe.

The SN55326 and SN75326 memory drivers can sink up to 600 milliamperes and operate from a single 5-volt supply. Each driver is similar to the sink drivers of the SN55325/SN75325. The four output transistors share a common base-drive resistor and it is recommended that only one of the four driver gates be selected at a time. Output-transistor base current may be increased by connecting an external resistor between  $R_{ext}$  (pin 4) and  $V_{CC}$ . Each output collector is protected from voltage surges during inductive switching by a clamp diode in parallel with its internal pull-up resistor. The two clamp pins may be returned to a power supply of from 4.5 volts to 24 volts.

The SN55327 and SN75327 memory switches can source or sink up to 600 milliamperes and operate from two supplies; one of five volts and the other from 4.5 volts to 24 volts. Each switch is similar to the source drivers of the SN55325/SN75325. They can function as either sink drivers or source drivers since the voltages at the output transistor terminals are capable of swinging between  $V_{CC2}$  and ground. The four output transistors share a common base-drive resistor and it is recommended that only one of the four outputs be selected at a time. An internal base-drive resistor is available on the chip and can be

# TYPES SN55326, SN55327, SN75326, SN75327

## MEMORY CORE DRIVERS

### description (continued)

used by connecting Node R (pin 4) to  $R_{int}$  (pin 5). This resistor provides adequate base current to the output transistors for output sink currents up to 375 milliamperes with  $V_{CC2}$  at 15 volts or 600 milliamperes with  $V_{CC2}$  at 24 volts. Base current can be regulated to within  $\pm 5$  percent by substituting for this resistor an external resistor connected between Node R (pin 4) and  $V_{CC2}$  with  $R_{int}$  (pin 5) remaining open. This method is preferable in high-duty-cycle, high-power applications since the power dissipated in this resistor is outside the package. When a source current and  $V_{CC2}$  voltage other than the above values are required, it is recommended that the base drive be supplied through an external resistor of the appropriate value calculated using Equation 1 shown in the SN55325, SN75325 data sheet.

FUNCTION TABLE

INPUTS					OUTPUTS			
ADDRESS				STROBE	W	X	Y	Z
A	B	C	D	S				
L	H	H	H	L	ON	OFF	OFF	OFF
H	L	H	H	L	OFF	ON	OFF	OFF
H	H	L	H	L	OFF	OFF	ON	OFF
H	H	H	L	L	OFF	OFF	OFF	ON
H	H	H	H	X	OFF	OFF	OFF	OFF
X	X	X	X	H	OFF	OFF	OFF	OFF

H = high level, L = low level, X = Irrelevant

NOTE: Not more than one output is to be on at any one time.

The SN55326 and SN55327 circuits are characterized for operation over the full military temperature range of  $-55^{\circ}\text{C}$  to  $125^{\circ}\text{C}$ ; the SN75326 and SN75327 are characterized for operation from  $0^{\circ}\text{C}$  to  $70^{\circ}\text{C}$ .

### absolute maximum ratings over operating free-air temperature range (unless otherwise noted)

	SN55326	SN75326	SN55327	SN75327	UNIT
Supply voltage, $V_{CC}$ or $V_{CC1}$ (see Note 1)	7	7	7	7	V
Supply voltage, $V_{CC2}$			25	25	V
Input voltage, any address or strobe	5.5	5.5	5.5	5.5	V
Output collector voltage	25	25	25	25	V
Output clamp voltage	25	25			V
Output collector current	750	750	750	750	mA
Continuous total dissipation at (or below) $25^{\circ}\text{C}$ free-air temperature (see Note 2)	J package	1375	1375	1375	mW
	N package		1150	1150	
Operating free-air temperature range	$-55$ to $125$	$0$ to $70$	$-55$ to $125$	$0$ to $70$	$^{\circ}\text{C}$
Storage temperature range	$-65$ to $150$	$-65$ to $150$	$-65$ to $150$	$-65$ to $150$	$^{\circ}\text{C}$
Lead temperature $1/16$ inch from case for 60 seconds: J package	300	300	300	300	$^{\circ}\text{C}$
Lead temperature $1/16$ inch from case for 10 seconds: N package	260	260	260	260	$^{\circ}\text{C}$

### recommended operating conditions

	SN55326			SN75326			SN55327			SN75327			UNIT
	MIN	NOM	MAX	MIN	NOM	MAX	MIN	NOM	MAX	MIN	NOM	MAX	
Supply voltage, $V_{CC}$ or $V_{CC1}$	4.5	5	5.5	4.5	5	5.5	4.5	5	5.5	4.5	5	5.5	V
Supply voltage, $V_{CC2}$							4.5		24	4.5		24	V
Output collector voltage			24			24			24			24	V
Output-clamp voltage, $V_{(clamp)}$	4.5		24	4.5		24							V
Output collector current			600			600			600			600	mA
Operating free-air temperature, $T_A$	$-55$		125	0		70	$-55$		125	0		70	$^{\circ}\text{C}$

NOTES: 1. Voltage values are with respect to network ground terminal(s).

2. For operation above  $25^{\circ}\text{C}$  free-air temperature, refer to Dissipation Derating Curves in the Thermal Information section, which starts on page 2-1. In the J package, these chips are alloy-mounted.

# TYPES SN55326, SN55327, SN75326, SN75327 MEMORY CORE DRIVERS

SN55326, SN75326 electrical characteristics over recommended operating free-air temperature range (unless otherwise noted)

PARAMETER		TEST CONDITIONS†	SN55326			SN75326			UNIT
			MIN	TYP‡	MAX	MIN	TYP‡	MAX	
V <sub>IH</sub>	High-level input voltage		2			2			V
V <sub>IL</sub>	Low-level input voltage		0.8			0.8			V
V <sub>IK</sub>	Input clamp voltage	V <sub>CC</sub> = 4.5 V, I <sub>I</sub> = -10 mA, T <sub>A</sub> = 25°C	-1 -1.7			-1 -1.7			V
V <sub>OH</sub>	High-level output voltage	V <sub>CC</sub> = 4.5 V, I <sub>O</sub> = 0	19 23			19 23			V
V <sub>(sat)</sub>	Saturation voltage	V <sub>CC</sub> = 4.5 V, I <sub>(sink)</sub> = 600 mA§, See Note 3, Full range, T <sub>A</sub> = 25°C	0.9			0.9			V
			0.43 0.7			0.43 0.75			
V <sub>F(clamp)</sub>	Output-clamp-diode forward voltage	V <sub>(clamp)</sub> = 0, I <sub>(clamp)</sub> = -10 mA, T <sub>A</sub> = 25°C	1.5			1.5			V
I <sub>(clamp)</sub>	Output-clamp current, one output on	I <sub>(sink)</sub> = 50 mA, T <sub>A</sub> = 25°C	5 7			5 7			mA
I <sub>I</sub>	Input current at maximum input voltage	Address	1			1			mA
		Strobe	4			4			
I <sub>IH</sub>	High-level input current	Address	40			40			μA
		Strobe	160			160			
I <sub>IL</sub>	Low-level input current	Address	-1 -1.6			-1 -1.6			mA
		Strobe	-4 -6.4			-4 -6.4			
I <sub>CC(off)</sub>	Supply current, all outputs off	All inputs at 5 V, T <sub>A</sub> = 25°C	18 25			18 25			mA
I <sub>CC(on)</sub>	Supply current, one output on	I <sub>(sink)</sub> = 50 mA, T <sub>A</sub> = 25°C	58 75			58 75			mA

SN55326, SN75326 switching characteristics, V<sub>CC</sub> = 5 V, T<sub>A</sub> = 25°C

PARAMETER¶	TO (OUTPUT)	TEST CONDITIONS§	MIN	TYP	MAX	UNIT
t <sub>PLH</sub>	W, X, Y, or Z	V <sub>S</sub> = V <sub>(clamp)</sub> = 15 V, R <sub>L</sub> = 24 Ω, C <sub>L</sub> = 25 pF, See Figure 3	30 50		ns	
t <sub>PHL</sub>			25 50			
t <sub>TLH</sub>	W, X, Y, or Z		7 15		ns	
t <sub>THL</sub>			10 20			
t <sub>s</sub>	W, X, Y, or Z		24 35		ns	
V <sub>OH</sub>	W, X, Y, or Z	V <sub>S</sub> = V <sub>(clamp)</sub> = 24 V, R <sub>L</sub> = 47 Ω, C <sub>L</sub> = 25 pF, I <sub>(sink)</sub> ≈ 500 mA, See Figure 3	V <sub>S</sub> -25		mV	

† Unless otherwise noted, V<sub>CC</sub> = 5.5 V, V<sub>(clamp)</sub> = 24 V. See Figure 1.

‡ All typical values are at T<sub>A</sub> = 25°C.

§ Under these conditions, not more than one output is to be on at any one time.

¶ t<sub>PLH</sub> ≡ propagation delay time, low-to-high-level output

t<sub>PHL</sub> ≡ propagation delay time, high-to-low-level output

t<sub>TLH</sub> ≡ transition time, low-to-high-level output

t<sub>THL</sub> ≡ transition time, high-to-low-level output

t<sub>s</sub> ≡ Storage time

V<sub>OH</sub> ≡ High-level output voltage (after switching)

NOTE 3: These parameters must be measured using pulse techniques. t<sub>w</sub> = 200 μs, duty cycle < 2%.

For typical characteristic curves, Figures 11 through 14 of the SN55325/SN75325 data sheet apply for these circuits.

# TYPES SN55326, SN55327, SN75326, SN75327

## MEMORY CORE DRIVERS

SN55327, SN75327 electrical characteristics over recommended operating free-air temperature range (unless otherwise noted)

PARAMETER		TEST CONDITIONS†		SN55327		SN75327		UNIT
				MIN	TYP‡	MAX	MIN	
V <sub>IH</sub>	High-level input voltage			2		2		V
V <sub>IL</sub>	Low-level input voltage				0.8		0.8	V
V <sub>IK</sub>	Input clamp voltage	V <sub>CC1</sub> = 4.5 V, T <sub>A</sub> = 25°C	I <sub>I</sub> = -10 mA		-1 -1.7		-1 -1.7	V
I <sub>(off)</sub>	Collectors terminal off-state current	V <sub>CC1</sub> = 4.5 V, V <sub>(col)</sub> = 24 V	Full range T <sub>A</sub> = 25°C		500		200	μA
V <sub>(sat)</sub>	Saturation voltage	V <sub>CC1</sub> = 4.5 V, V <sub>O</sub> = 0, I <sub>(source)</sub> = -600 mA§, See Notes 3 and 4	Full range T <sub>A</sub> = 25°C		0.9		0.9	V
I <sub>I</sub>	Input current at maximum input voltage	Address	V <sub>I</sub> = 5.5 V		1		1	mA
		Strobe			4		4	
I <sub>IH</sub>	High-level input current	Address	V <sub>I</sub> = 2.4 V		40		40	μA
		Strobe			160		160	
I <sub>IL</sub>	Low-level input current	Address	V <sub>I</sub> = 0.4 V		-1 -1.6		-1 -1.6	mA
		Strobe			-4 -6.4		-4 -6.4	
I <sub>CC(off)</sub>	Supply current, all outputs off	From V <sub>CC1</sub>	All inputs at 5 V, T <sub>A</sub> = 25°C		7 10		7 10	mA
		From V <sub>CC2</sub>			13 20		13 20	
I <sub>CC(on)</sub>	Supply current, one output on	From V <sub>CC1</sub>	V <sub>(col)</sub> = 6 V, T <sub>A</sub> = 25°C, I <sub>(source)</sub> = -50 mA, See Note 3		8 12		8 12	mA
		From V <sub>CC2</sub>			36 55		36 55	

### SN55327, SN75327 switching characteristics, V<sub>CC1</sub> = 5 V, T<sub>A</sub> = 25°C

PARAMETER ¶	TO (OUTPUT)	TEST CONDITIONS§	MIN	TYP	MAX	UNIT
t <sub>PLH</sub>	Collectors	V <sub>S</sub> = V <sub>CC2</sub> = 15 V, R <sub>L</sub> = 24 Ω, C <sub>L</sub> = 25 pF, See Figure 3 and Note 4		35	55	ns
t <sub>PHL</sub>	W, Z or X, Y			30	55	
t <sub>TLH</sub>	W, X, Y, or Z	V <sub>(col)</sub> = V <sub>CC2</sub> = 20 V, R <sub>L</sub> = 100 Ω, C <sub>L</sub> = 25 pF, See Figure 4 and Note 4		30		ns
t <sub>THL</sub>				10		
V <sub>OH</sub>	Collectors W, Z or X, Y	V <sub>S</sub> = V <sub>CC2</sub> = 24 V, R <sub>L</sub> = 47 Ω, C <sub>L</sub> = 25 pF, I <sub>(sink)</sub> ≈ 500 mA, See Figure 3 and Note 4	V <sub>S</sub> - 25			mV

† Unless otherwise noted, V<sub>CC1</sub> = 5.5 V, V<sub>CC2</sub> = 24 V. See Figure 2.

‡ All typical values are at T<sub>A</sub> = 25°C.

§ Under these conditions, not more than one output is to be on at any one time.

¶ t<sub>PLH</sub> ≡ propagation delay time, low-to-high-level output

t<sub>PHL</sub> ≡ propagation delay time, high-to-low-level output

t<sub>TLH</sub> ≡ transition time, low-to-high-level output

t<sub>THL</sub> ≡ transition time, high-to-low-level output

V<sub>OH</sub> ≡ High-level output voltage (after switching)

NOTES: 3. These parameters must be measured using pulse techniques. t<sub>w</sub> = 200 μs, duty cycle ≤ 2%.

4. A 350-Ω resistor is connected between node R (pin 4) and V<sub>CC2</sub> (pin 1) with R<sub>int</sub> (pin 5) open.

For typical characteristic curves, Figures 11 through 14 of the SN55325/SN75325 data sheet apply for these circuits.

# TYPES SN55326, SN55327, SN75326, SN75327 MEMORY CORE DRIVERS

schematics

SN55326, SN75326

SN55327, SN75327

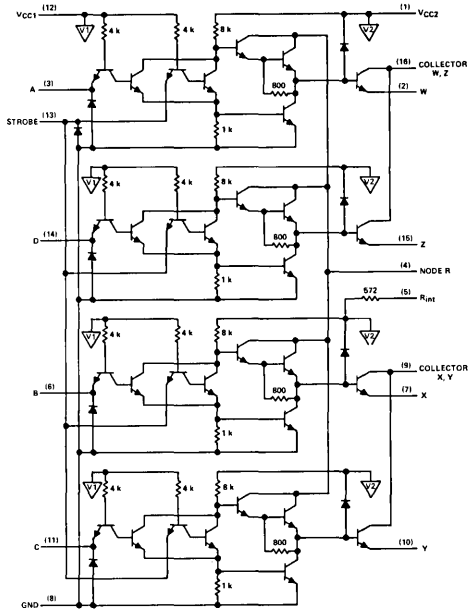
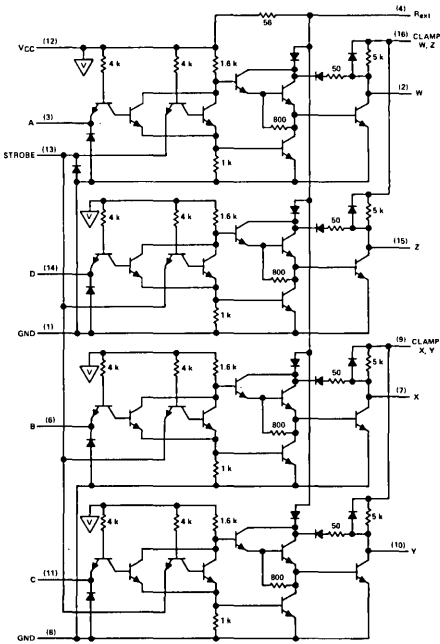

▽ ▽ ▹ ... V<sub>CC</sub>, V<sub>CC1</sub>, or V<sub>CC2</sub> bus, respectively.

Resistor values shown are nominal and in ohms.

## PARAMETER MEASUREMENT INFORMATION

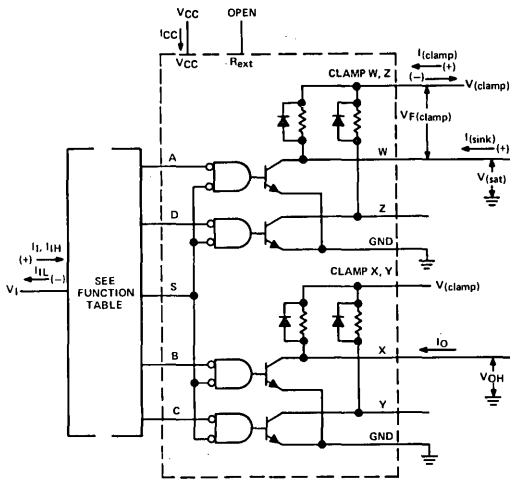
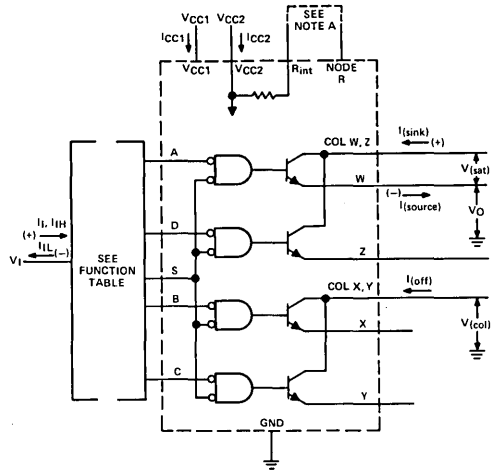

FIGURE 1—GENERALIZED TEST CIRCUIT  
FOR SN55326, SN75326



NOTE A: R<sub>int</sub> is connected to Node R unless otherwise noted.

FIGURE 2—GENERALIZED TEST CIRCUIT  
FOR SN55327, SN75327

8

# TYPES SN55326, SN55327, SN75326, SN75327 MEMORY CORE DRIVERS

## PARAMETER MEASUREMENT INFORMATION

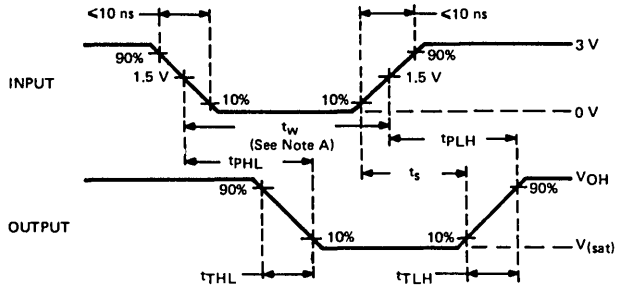
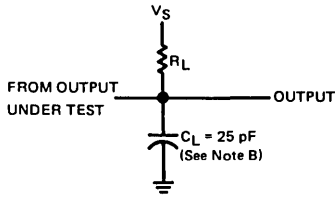

### LOAD CIRCUIT

### VOLTAGE WAVEFORMS

- NOTES: A. Input pulses are supplied by generators having the following characteristics:  $Z_{out} \approx 50 \Omega$ . For testing  $V_{OH}$  (after switching),  $t_w = 40 \mu\text{s}$ , PRR = 12.5 kHz. For all other tests,  $t_w = 200 \text{ ns}$ , duty cycle  $\le 1\%$ .  
B.  $C_L$  includes probe and jig capacitance.

FIGURE 3—SWITCHING TIMES

8

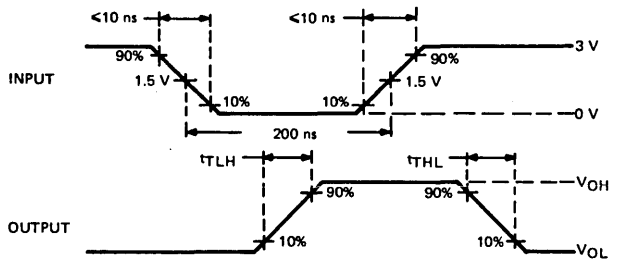
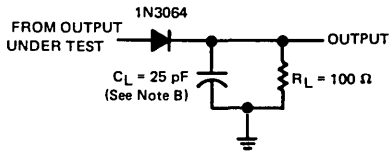

### LOAD CIRCUIT

### VOLTAGE WAVEFORMS

- NOTES: A. Input pulses are supplied by generators having the following characteristics:  $Z_{out} \approx 50 \Omega$ , duty cycle  $\le 1\%$ .  
B.  $C_L$  includes probe and jig capacitance.

FIGURE 4—SWITCHING TIMES



## INTERFACE CIRCUITS

## TYPES SN75328, SN75330 QUADRUPLE MEMORY SWITCHES

BULLETIN NO. DL-S 7712458, APRIL 1977

- Quadruple Interface for Core and Bubble Memories
- Characterized for Use to 600 mA
- 24-V Output Capability
- Output Transient Voltage Protection
- Fast Switching Times . . . 40 ns Typ
- Outputs Capable of Swinging Between  $V_{CC2}$  and Ground
- Source/Sink Base Drive Externally Adjustable
- TTL- or DTL-Compatible Inputs
- Input Clamping Diodes

### description

The SN75328 and SN75330 are monolithic integrated circuit memory switches with TTL logic inputs that are designed for use with core and bubble memories. Each device contains four 600-milliamperere memory switches and operates from two power supplies, one of 5 volts and the other from 4.75 volts to 24 volts. Each switch is similar to the SN75327 except that the strobe circuitry is omitted, which allows the collectors of the output transistors to be assigned to individual package pins.

Each switch can function as either source driver or sink driver since the voltages at the output transistor terminals are capable of swinging between  $V_{CC2}$  and ground. On SN75328 the base drive of all four output transistors is provided by connecting an external resistor of the appropriate value between  $V_{CC2}$  and Node R. On SN75330 the base drive of each individual output transistor is provided by connecting an external resistor of the appropriate value between  $V_{CC2}$  and the corresponding Node R. By using this method the base current may usually be regulated within  $\pm 5\%$ , and the power dissipated by this resistor is external to the package and allows the integrated circuit to operate at higher currents for a given junction temperature.

The SN75328 and SN75330 are characterized for operation from  $0^{\circ}\text{C}$  to  $70^{\circ}\text{C}$ .

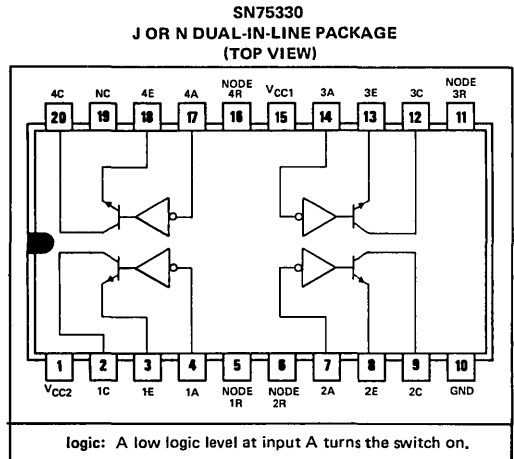
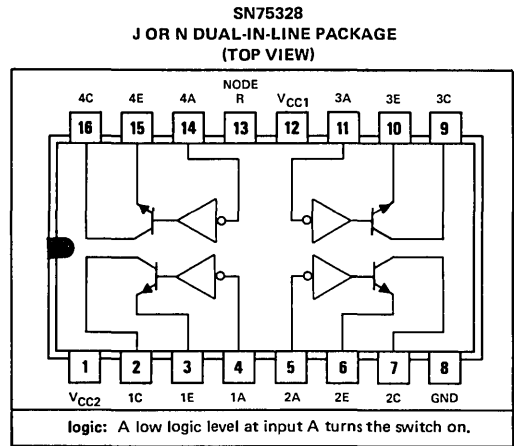

NC = No internal connection

### schematic of each input

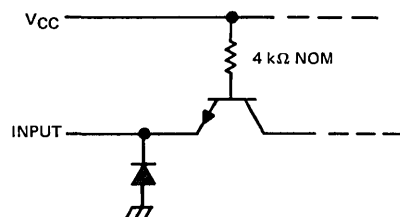

# TYPES SN75328, SN75330

## QUADRUPLE MEMORY SWITCHES

absolute maximum ratings over operating free-air temperature range (unless otherwise noted)

Supply voltage, $V_{CC1}$ (see Note 1)	7 V
Supply voltage, $V_{CC2}$	25 V
Input voltage	5.5 V
Output collector voltage	25 V
Output collector current	750 mA
Continuous total dissipation at (or below) 25°C free-air temperature (see Note 2): J package	1375 mW
N package	1150 mW
Operating free-air temperature range	0°C to 70°C
Storage temperature range	-65°C to 150°C
Lead temperature 1/16 inch from case for 60 seconds: J package	300°C
Lead temperature 1/16 inch from case for 10 seconds: N package	260°C

- NOTES: 1. All voltage values are with respect to network ground terminal.  
 2. For operation above 25°C free-air temperature, refer to Dissipation Derating Curves in the Thermal Information section, which starts on page 2-1. In the J package, SN75328 and SN75330 chips are alloy-mounted.

recommended operating conditions

	MIN	NOM	MAX	UNIT
Supply voltage, $V_{CC1}$	4.75	5	5.25	V
Supply voltage, $V_{CC2}$	4.75		24	V
Output collector voltage			24	V
Output collector current			600	mA
Operating free-air temperature, $T_A$	0		70	°C

electrical characteristics over recommended free-air temperature range (unless otherwise noted)

PARAMETER	TEST CONDITIONS†	MIN	TYP‡	MAX	UNIT	
$V_{IH}$	High-level input voltage	2			V	
$V_{IL}$	Low-level input voltage			0.8	V	
$V_{IK}$	Input clamp voltage	$V_{CC1} = 4.75$ V, $I_I = -10$ mA			-1 -1.7	V
$I_{(off)}$	Collector off-state current	$V_{CC1} = 4.75$ V, $V_{(col)} = 24$ V, See Figure 1			200	µA
$V_{(sat)}$	Saturation voltage	$V_{CC1} = 4.75$ V, $V_{CC2} = 15$ V, See Figure 1, See Note 3	$R_L = 285$ Ω, $R_{ext} = 3.9$ kΩ, $I_{(sink)} \approx 50$ mA	120	200	mV
			$R_L = 95$ Ω, $R_{ext} = 1.3$ kΩ, $I_{(sink)} \approx 150$ mA	300	400	
			$R_L = 48$ Ω, $R_{ext} = 650$ Ω, $I_{(sink)} \approx 300$ mA §	420	550	
			$R_L = 32$ Ω, $R_{ext} = 430$ Ω, $I_{(sink)} \approx 450$ mA §	500	650	
		$R_L = 24$ Ω, $R_{ext} = 350$ Ω, $I_{(sink)} \approx 600$ mA §	600	750		
$I_I$	Input current at maximum input voltage	$V_I = 5.5$ V			1	mA
$I_{IH}$	High-level input current	$V_I = 2.4$ V			40	µA
$I_{IL}$	Low-level input current	$V_I = 0.4$ V			-1 -1.6	mA
$I_{CC(off)}$	Supply current, all outputs off	All inputs at 5 V, $T_A = 25^\circ$ C	From $V_{CC1}$	7	10	mA
			From $V_{CC2}$	13	20	
$I_{CC(on)}$	Supply current, one output on	$V_{(col)} = 6$ V, $I_{(source)} = -50$ mA, $T_A = 25^\circ$ C, See Note 3	From $V_{CC1}$	8	12	mA
			From $V_{CC2}$	36	55	

† Unless otherwise noted,  $V_{CC1} = 5.25$  V,  $V_{CC2} = 24$  V.

‡ All typical values are at  $T_A = 25^\circ$  C.

§ Under these conditions, only one output is to be on at any one time.

NOTE 3: These parameters must be measured using pulse techniques,  $t_w = 200$  µs, duty cycle  $\leq 2\%$ .

# TYPES SN75328, SN75330 QUADRUPLE MEMORY SWITCHES

switching characteristics,  $V_{CC1} = 5\text{ V}$ ,  $T_A = 25^\circ\text{C}$

PARAMETER	TEST CONDITIONS <sup>§</sup>	MIN	TYP	MAX	UNIT
$t_{PLH}$ Propagation delay time, low-to-high level output	$V_S = V_{CC2} = 15\text{ V}$ , $R_L = 24\ \Omega$ , $C_L = 25\ \text{pF}$ , $R_{ext} = 350\ \Omega$ , See Figure 2		40	60	ns
$t_{PHL}$ Propagation delay time, high-to-low level output			30	50	ns
$t_{TLH}$ Transition time, low-to-high level output			20	30	ns
$t_{THL}$ Transition time, high-to-low level output			15	25	ns
$V_{OH}$ High-level output voltage after switching	$V_S = V_{CC2} = 24\text{ V}$ , $R_L = 47\ \Omega$ , $C_L = 25\ \text{pF}$ , $R_{ext} = 350\ \Omega$ , $I_{(sink)} \approx 500\ \text{mA}$ , See Figure 2	$V_S - 25$			mV

<sup>§</sup>Under these conditions, only one output is to be on at any one time.

## PARAMETER MEASUREMENT INFORMATION<sup>†</sup>

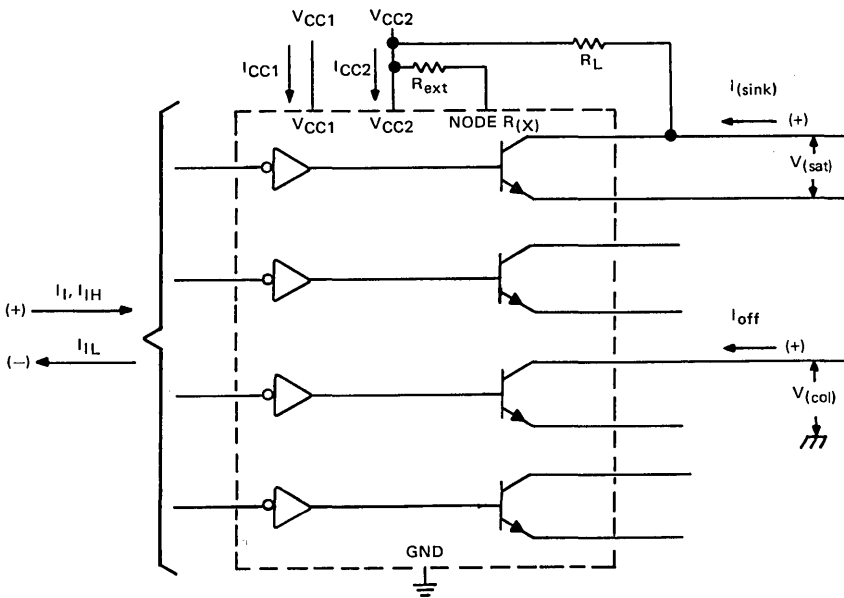

FIGURE 1—GENERALIZED TEST CIRCUIT

<sup>†</sup>Arrows indicate actual direction of current flow. Current into a terminal is a positive value.

# TYPES SN75328, SN75330 QUADRUPLE MEMORY SWITCHES

## PARAMETER MEASUREMENT INFORMATION

### switching characteristics

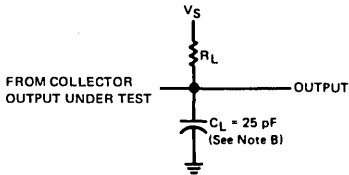

LOAD CIRCUIT

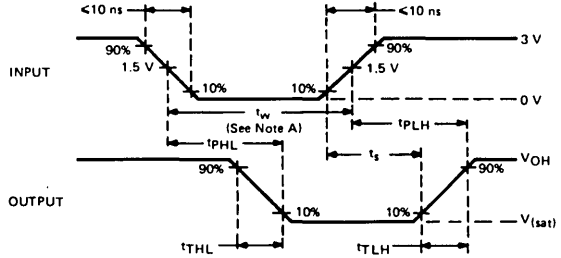

VOLTAGE WAVEFORMS

NOTES: A. Input pulses are supplied by generators having the following characteristics:  $Z_{out} \approx 50 \Omega$ . For testing  $V_{OH}$  after switching,  $t_w = 40 \mu s$ , PRR = 12.5 kHz. For all other tests,  $t_w = 200 ns$ , duty cycle  $\leq 1\%$ .  
B.  $C_L$  includes probe and jig capacitance.

FIGURE 2—SWITCHING TIMES

## TYPICAL APPLICATION DATA

### external resistor calculation

The value of  $R_{ext}$  for any particular output current level may be determined by using the following equation:

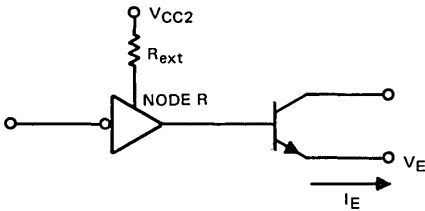

$$R_{ext} = \frac{16(V_{CC2} - V_E - 2.2)}{|I_E| - 1.6(V_{CC2} - V_E - 2.9)}$$

where  $I_E$  is in mA and  $R_{ext}$  in  $k\Omega$ .

Example 1. For  $I_E = -300 mA$ ,  $V_E = 4 V$ ,  $V_{CC2} = 24 V$   
 $R_{ext} = 1 k\Omega$

Example 2. For  $I_E = -600 mA$ ,  $V_E = 4 V$ ,  $V_{CC2} = 24 V$   
 $R_{ext} = 0.5 k\Omega$

# Display Drivers

**DISPLAY DRIVERS  
FOR COMMERCIAL TEMPERATURE RANGE**

DISPLAY TYPE	DESCRIPTION	INPUT COMPATIBILITY	POWER SUPPLIES	DRIVERS PER PACKAGE	DEVICE TYPE	PACKAGE TYPE	ADDITIONAL FEATURES	PAGE NO.
AC PLASMA DISPLAYS	AXIS DRIVERS	CMOS	$V_{CC1} = 12 V$ , $V_{CC2}$ variable from 40 V to 90 V	4	SN75426B	J,N	<ul style="list-style-type: none"> <li>Independent addressing of each gate for serial and parallel applications</li> <li>High input impedance (typically 1 megohm)</li> <li>30-mA clamp diodes on output</li> <li>Switches 70 V in 1.2 <math>\mu</math>s</li> <li>AND driver (SN75426); NAND driver (SN75427)</li> </ul>	9-9
					SN75427B	J,N		
		CMOS	$V_{CC1} = 12 V$ , $V_{CC2}$ variable from $V_{CC1}$ to 100 V	32	SN75500A	N	<ul style="list-style-type: none"> <li>High-speed serially shifted data input (4 MHz max)</li> <li>Fast output transitions (less than 150 ns)</li> <li>25-mA output current capability</li> <li>Output short-circuit capability</li> <li>Static shift registers can retain data on all outputs of SN75501 and SN75503A indefinitely</li> <li>X-axis driver — SN75500A and SN75502A</li> <li>Y-axis driver — SN75501A and SN75503A perform Y-axis sustaining function)</li> </ul>	9-43
					SN75502A	N		
					SN75501A	N		9-47
					SN75503A	N		
LED DISPLAYS	SEGMENT DRIVERS	MOS	10 V	4	SN75491	N	<ul style="list-style-type: none"> <li>50-mA source/sink capability</li> </ul>	9-25
			20 V	4	SN75491A	N		
			Variable from 3.2 V to 8.8 V	4	SN75493	N		
	DIGIT DRIVERS	MOS	10 V	6	SN75492	N	<ul style="list-style-type: none"> <li>250-mA sink capability</li> </ul>	9-25
			20 V	6	SN75492A	N		
			Variable from 3.2 V to 8.8 V	6	SN75494	N		
		TTL	10 V	6	SN75496	N	<ul style="list-style-type: none"> <li>250-mA sink capability</li> </ul>	9-37
			20 V	6	SN75496A	N		
		MOS, TTL	Variable from 2.7 V to 6.6 V	7	SN75497	N	<ul style="list-style-type: none"> <li>100-mA sink capability</li> <li>Input threshold . . . 2.7 V max</li> <li>Low voltage saturating outputs (0.4 V maximum)</li> </ul>	9-39
	MOS, TTL	Variable from 2.7 V to 6.6 V	9	SN75498	N	<ul style="list-style-type: none"> <li>100-mA sink capability</li> <li>Input threshold . . . 2.7 V max</li> </ul>	9-39	

**DISPLAY DRIVERS**  
FOR COMMERCIAL TEMPERATURE RANGE (continued)

DISPLAY TYPE	DESCRIPTION	INPUT COMPATIBILITY	POWER SUPPLIES	DRIVERS PER PACKAGE	DEVICE TYPE	PACKAGE TYPE	ADDITIONAL FEATURES	PAGE NO.
GAS DISCHARGE DISPLAYS	HIGH-VOLTAGE BCD-TO-SEVEN-SEGMENT DECODER CATHODE DRIVERS	TTL	5 V	7	SN75480	N	<ul style="list-style-type: none"> <li>• Outputs regulated to insure constant brightness</li> <li>• Blanking and ripple-blanking provisions</li> <li>• High off-state breakdown voltage (120 V typical)</li> <li>• Designed for seven segment displays such as Beckman and Panaplex II<sup>◊</sup></li> </ul>	9-13
		CMOS	Variable from 5 V to 15 V	7½	SN75580	N	<ul style="list-style-type: none"> <li>• Same features as the SN75480 plus:</li> <li>• Decimal point provided</li> <li>• Latches to hold BCD information</li> <li>• Lower supply power requirements</li> <li>• Higher output voltage breakdown capability</li> </ul>	9-59
		TTL	Variable from 4.75 V to 15 V	7½	SN75584A	N	<ul style="list-style-type: none"> <li>• Higher output voltage breakdown capability</li> </ul>	9-65
	ANODE DRIVER	MOS	V <sub>EE</sub> = -55 V, V <sub>BB</sub> = -18 V	6	SN75481	N	<ul style="list-style-type: none"> <li>• 13-mA output capability</li> <li>• Designed for time-multiplexed displays such as Panaplex II<sup>◊</sup></li> </ul>	9-17
THERMAL PRINT DISPLAYS	THERMAL PRINTHEAD DRIVERS	TTL, CMOS	±5 V	6	SN75490	J,N	<ul style="list-style-type: none"> <li>• Common strobe</li> <li>• 30-mA source, 50-mA sink capability</li> </ul>	9-21
		MOS	5 V	7	SN75270	J,N	<ul style="list-style-type: none"> <li>• Single ended, noninverting operation</li> </ul>	9-5
VACUUM FLUORESCENT DISPLAYS	DRIVERS	CMOS	V <sub>CC1</sub> = 12 V, V <sub>CC2</sub> = 60 V	12	SN75510	N	<ul style="list-style-type: none"> <li>• 12 drivers for dot-matrix or segmented displays</li> <li>• 60-V output and 25-mA input</li> <li>• Serial input</li> </ul>	9-51
				12	SN75511	N	<ul style="list-style-type: none"> <li>• SN75511 has latched outputs for continuous display</li> </ul>	9-55

◊Trademark of the Burroughs Corporation





# INTERFACE CIRCUITS

# TYPE SN75270 7-UNIT MOS-TO-TTL CONVERTER AND THERMAL PRINTHEAD DRIVER ARRAY

BULLETIN NO. DL-S 7712061, SEPTEMBER 1973—REVISED APRIL 1977

J OR N  
DUAL-IN-LINE PACKAGE (TOP VIEW)

- 7 Single-Ended Noninverting Drivers Per Package
- Inputs Compatible with MOS
- TTL-Compatible Outputs
- Single 5-V Supply

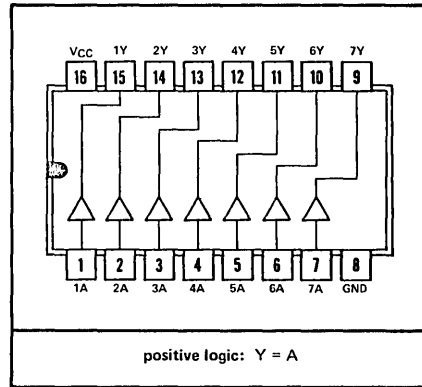

## description

The SN75270 is a monolithic integrated circuit designed for use as a sense amplifier or thermal printhead driver. As a sense amplifier, the device can be used to convert from MOS to TTL levels. As a thermal printhead driver, this device is used with EPN3600-type thermal printheads.

The SN75270 is characterized for operation from 0°C to 70°C.

## schematic (each driver)

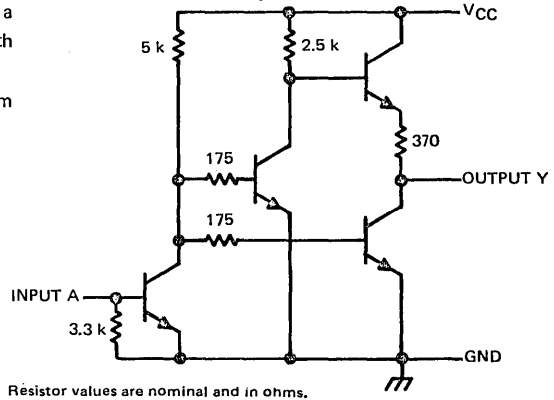

## absolute maximum ratings over operating free-air temperature range (unless otherwise noted)

Supply voltage, $V_{CC}$ (see Note 1)	7 V
Input current	4 mA
Continuous total dissipation at (or below) 25°C free-air temperature (see Note 2)	800 mW
Operating free-air temperature range	0°C to 70°C
Storage temperature range	-65°C to 150°C
Lead temperature 1/16 inch from case for 60 seconds: J package	300°C
Lead temperature 1/16 inch from case for 10 seconds: N package	260°C

## recommended operating conditions

	MIN	NOM	MAX	UNIT
Supply voltage, $V_{CC}$	4.75	5	5.25	V
High-level input current, $I_{IH}$	0.5		2	mA
Low-level input current, $I_{IL}$	0		0.1	mA
Operating free-air temperature, $T_A$	0		70	°C

NOTES: 1. Voltage values are with respect to network ground terminal.

2. For operation above 25°C free-air temperature, refer to Dissipation Derating Curves in the Thermal Information Section, which starts on page 2-1. In the J package, SN75270 chips are glass-mounted.

TEXAS INSTRUMENTS  
INCORPORATED

POST OFFICE BOX 225012 • DALLAS, TEXAS 75265

# TYPE SN75270 7-UNIT MOS-TO-TTL CONVERTER AND THERMAL PRINTHEAD DRIVER ARRAY

electrical characteristics over recommended operating free-air temperature range

PARAMETER	TEST CONDITIONS	MIN	TYP	MAX	UNIT
$V_{OH}$ High-level output voltage	$V_{CC} = 4.75 \text{ V}$ , $I_{IH} = 500 \mu\text{A}$ , $I_{OH} = -80 \mu\text{A}$	2.4			V
$V_{OL}$ Low-level output voltage	$V_{CC} = 4.75 \text{ V}$ , $I_{IL} = 100 \mu\text{A}$ , $I_{OL} = 3.2 \text{ mA}$			0.4	V
$I_{OH}$ High-level output current	$V_{CC} = 4.75 \text{ V}$ , $I_{IH} = 500 \mu\text{A}$ , $V_O = 1 \text{ V}$	-5			mA
	$V_{CC} = 5.25 \text{ V}$ , $I_{IH} = 500 \mu\text{A}$ , $V_O = 0.25 \text{ V}$			-15	
$I_{CCL}$ Total supply current, all outputs low	$V_{CC} = 5 \text{ V}$ , $I_{IL} = 100 \mu\text{A}$ , $I_O = 0$		20	35	mA

switching characteristics,  $T_A = 25^\circ\text{C}$

PARAMETER	TEST CONDITIONS	MIN	TYP	MAX	UNIT
$t_{PLH}$ Propagation delay time, low-to-high-level output	$V_{CC} = 5 \text{ V}$ , $C_L = 15 \text{ pF}$ , $R_L = 1.5 \text{ k}\Omega$ , See Figure 1		30		ns
$t_{PHL}$ Propagation delay time, high-to-low-level output			8		ns

## PARAMETER MEASUREMENT INFORMATION

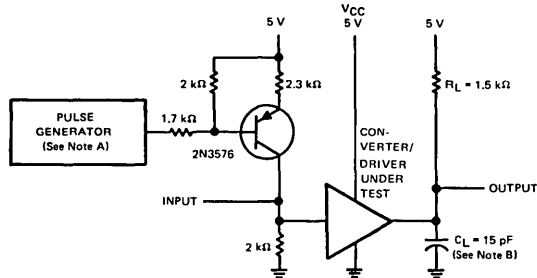

NOTES: A. The pulse generator has the following characteristics:  $Z_{out} = 50 \Omega$ ,  $t_r < 10 \text{ ns}$ ,  $t_f < 10 \text{ ns}$ ,  $PRR = 500 \text{ kHz}$ ,  $t_w = 500 \text{ ns}$ .  
B.  $C_L$  includes probe and jig capacitance.

### TEST CIRCUIT

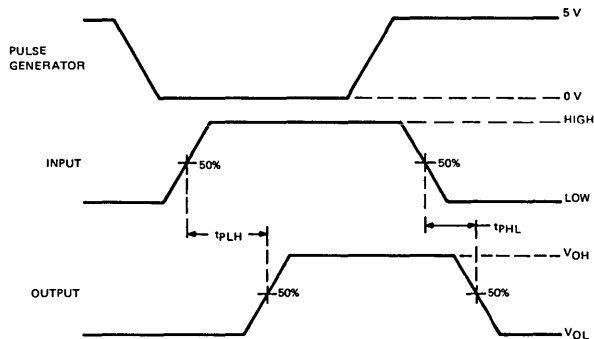

VOLTAGE WAVEFORMS

FIGURE 1

# TYPE SN75270 7-UNIT MOS-TO-TTL CONVERTER AND THERMAL PRINTHEAD DRIVER ARRAY

## TYPICAL APPLICATION DATA

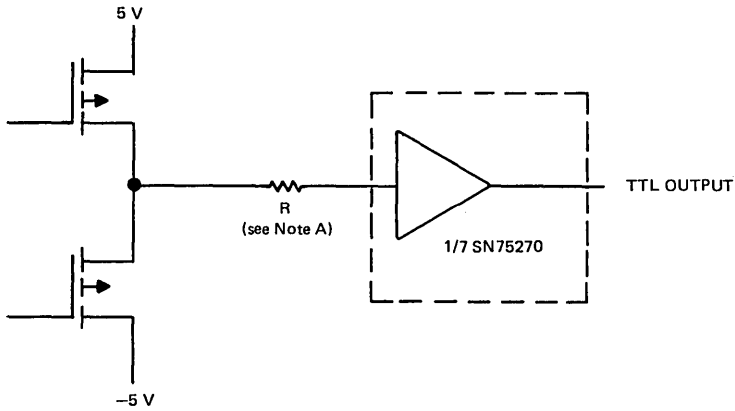

Note A:

$$R = \frac{V_{OH} - V_{BE}}{I_{OH}}$$

$V_{OH}$  = High-level output voltage of MOS device  
 $V_{BE}$  = Base-Emitter voltage of input transistor of SN75270  
 $I_{OH}$  = High-level output current of MOS device

example: let  $V_{OH} = 4\text{ V}$   
 $I_{OH} = 1\text{ mA}$   
 $V_{BE} = 0.7\text{ V}$

$$R = \frac{4 - 0.7}{1} = 3.3\text{ k}\Omega$$

FIGURE 2—MOS TO SN75270 CONNECTION

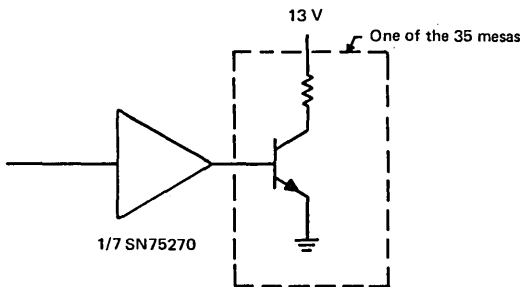

FIGURE 3—THERMAL PRINTHEAD DRIVER FOR  
THE EPN3600 THERMAL PRINTHEAD



# INTERFACE CIRCUITS

# TYPES SN55426B, SN55427B, SN75426B, SN75427B AC PLASMA DISPLAY DRIVERS

BULLETIN NO. DL-S 12499, MARCH 1979

- 90-V Output Swing
- CMOS-Compatible Inputs
- Quad Drivers with Independent Addressing of Each Gate for Serial or Parallel Applications
- High Data Input Impedance . . . 1 MΩ Typ
- 30-mA Clamp Diodes on Output

### description

The SN55426B, SN55427B, SN75426B, and SN75427B are monolithic integrated-circuit plasma display drivers. The logic of the two drivers is complementary to permit controlled writing or erasing at a specified point on the display. The '426B noninverting pulser is normally near ground potential and is pulsed near V<sub>CC2</sub>, while the '427B inverting pulser is normally near V<sub>CC2</sub> potential and is pulsed near ground potential. The devices are designed to accept CMOS logic input signals and drive one display line per output.

There are four gates per package with individual data inputs. Additionally, each device has a strobe and a multiplex input controlling all four gates. The devices require two power supplies, the logic section power supply V<sub>CC1</sub>, and the high-voltage bias supply V<sub>CC2</sub>. V<sub>CC2</sub> controls the magnitude of the output swing.

Each output is designed to sustain 20-milliampere switching transients on the output. Each output is also protected by source and sink clamp diodes with 30-milliampere current capability. Each device is designed to be operated at 50 kilohertz but may be operated as high as 85 kilohertz.

The multiplex and strobe inputs (inputs M and S, respectively) act on all four gates simultaneously and aid in plasma panel design.

The SN55426B and SN55427B are characterized for operation over the full military temperature range of -55°C to 125°C. The SN75426B and SN75427B are characterized for operation from 0°C to 70°C.

### schematics of inputs and outputs

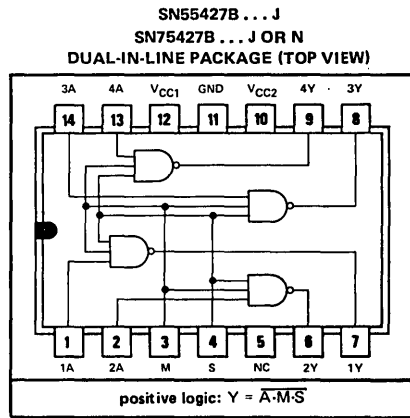
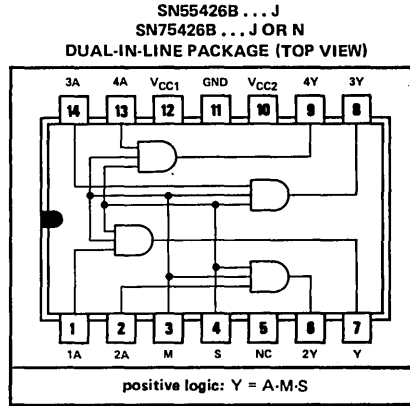
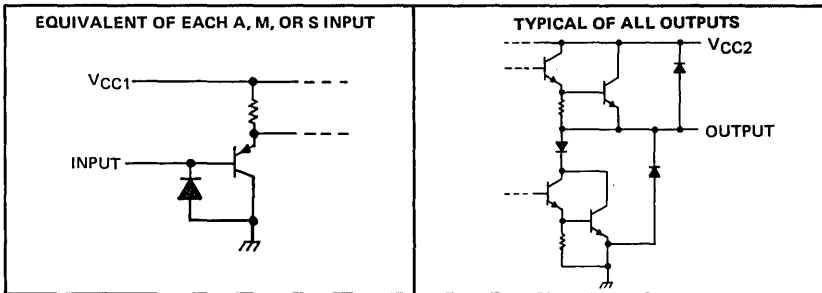

NC—No internal connection

### FUNCTION TABLE (EACH DRIVER)

INPUTS			OUTPUTS	
A	M	S	'426B	'427B
L	X	X	L	H
X	L	X	L	H
X	X	L	L	H
H	H	H	H	L

H=high level, L=low level, X=irrelevant

# TYPES SN55426B, SN55427B, SN75426B, SN75427B

## AC PLASMA DISPLAY DRIVERS

absolute maximum ratings over operating free-air temperature range (unless otherwise noted)

Supply voltage, $V_{CC1}$ (see Note 1)	15 V
Supply voltage, $V_{CC2}$	95 V
Input voltage, $V_I$	15 V
Continuous output current, $I_O$	20 mA
Continuous total dissipation at (or below) 25°C free-air temperature (see Note 2)	800 mW
Operating free-air temperature range: SN55426B, SN55427B	-55°C to 125°C
SN75426B, SN75427B	0°C to 70°C
Storage temperature range	-65°C to 150°C
Lead temperature 1/16 inch from case for 60 seconds: J package	300°C
Lead temperature 1/16 inch from case for 10 seconds: N package	260°C

- NOTES: 1. All voltage values are with respect to network ground terminal.  
2. For operation above 25°C free-air temperature, refer to Dissipation Derating Table.

DISSIPATION DERATING TABLE

PACKAGE	POWER RATING	DERATING FACTOR	ABOVE $T_A$
J	800 mW	8.2 mW/°C	52°C
N	800 mW	9.2 mW/°C	63°C

recommended operating conditions

	MIN	NOM	MAX	UNIT
Supply voltage, $V_{CC1}$	10	12	14	V
Supply voltage, $V_{CC2}$	40	70	90	V
Strobe frequency	0		85	kHz
Data input frequency	0	50	85	kHz
Width of strobe pulse	1.5	5		μs
Operating free-air temperature, $T_A$	0		70	°C

SN55426B, SN55427B electrical characteristics,  $V_{CC1} = 12\text{ V}$ ,  $V_{CC2} = 70\text{ V}$ ,  $T_A = -55^\circ\text{C}$  to  $125^\circ\text{C}$  (unless otherwise noted)

PARAMETER		TEST CONDITIONS		MIN	TYP†	MAX	UNIT
$V_{IH}$	High-level input voltage			7			V
$V_{IL}$	Low-level input voltage			3			V
$V_{OH}$	High-level output voltage	$V_{IH} = 7\text{ V}$ , $V_{IL} = 3\text{ V}$	$I_O = -1\text{ mA}$ $I_O = -15\text{ mA}$	$V_{CC2}-4$ $V_{CC2}-8$	$V_{CC2}-1$ $V_{CC2}-1.8$		V
$V_{OL}$	Low-level output voltage	$V_{IH} = 7\text{ V}$ , $V_{IL} = 3\text{ V}$	$I_O = 1\text{ mA}$ $I_O = 15\text{ mA}$		2 3.5	4 8	V
$V_{OK}$	Output clamp voltage	Output high, Output low,	$I_O = 30\text{ mA}$ $I_O = -30\text{ mA}$	$V_{CC2}+0.8$	$V_{CC2}+2$		V
$I_{IH}$	High-level input current	A M, S	$V_{IH} = 12\text{ V}$		12 50	60 200	μA
$I_{CC1}$	Supply current, logic section			$V_{CC1} = 12\text{ V}$ , $V_{CC2} = 90\text{ V}$	All inputs at 12 V	10	15
$I_{CC2}$	Supply current, output section	No load	All outputs high All outputs low		1.1 0.1	1.7 0.6	mA
$I_{CC1(av)}$	Average supply current, logic section	$t_w = 5\text{ μs}$ ,	$f = 50\text{ kHz}$ ,		10		mA
$I_{CC2(av)}$	Average supply current, output section	No load			1.3		mA

†All typical values are at 25°C.

# TYPES SN55426B, SN55427B, SN75426B, SN75427B AC PLASMA DISPLAY DRIVERS

SN75426B, SN75427B electrical characteristics,  $V_{CC1} = 12\text{ V}$ ,  $V_{CC2} = 70\text{ V}$ ,  $T_A = 0^\circ\text{C}$  to  $70^\circ\text{C}$   
(unless otherwise noted)

PARAMETER		TEST CONDITIONS		MIN	TYP†	MAX	UNIT	
$V_{IH}$	High-level input voltage			7			V	
$V_{IL}$	Low-level input voltage					3	V	
$V_{OH}$	High-level output voltage	$V_{IH} = 7\text{ V}$ , $V_{IL} = 3\text{ V}$	$I_O = -1\text{ mA}$ $I_O = -15\text{ mA}$	$V_{CC2}-3$ $V_{CC2}-6$	$V_{CC2}-1$ $V_{CC2}-1.8$		V	
$V_{OL}$	Low-level output voltage	$V_{IH} = 7\text{ V}$ , $V_{IL} = 3\text{ V}$	$I_O = 1\text{ mA}$ $I_O = 15\text{ mA}$		2 3.5	3 6	V	
$V_{OK}$	Output clamp voltage	Output high, Output low,		$I_O = 30\text{ mA}$ $I_O = -30\text{ mA}$	$V_{CC2}+0.8$ -0.9	$V_{CC2}+1.5$ -1.5	V	
$I_{IH}$	High-level input current	A M, S	$V_{IH} = 12\text{ V}$		12 50	30 100	$\mu\text{A}$	
$I_{CC1}$	Supply current, logic section	$V_{CC1} = 12\text{ V}$ , $V_{CC2} = 90\text{ V}$ , No load		All inputs at 12 V All outputs high		10 1.1	14 1.4	mA
$I_{CC2}$	Supply current, output section			All outputs low		0.1	0.5	mA
$I_{CC1(av)}$	Average supply current, logic section	$t_w = 5\ \mu\text{s}$ , $f = 50\text{ kHz}$ ,				10		mA
$I_{CC2(av)}$	Average supply current, output section	No load				1.3		mA

† All typical values are at  $25^\circ\text{C}$ .

switching characteristics,  $V_{CC1} = 12\text{ V}$ ,  $V_{CC2} = 70\text{ V}$ ,  $T_A = 25^\circ\text{C}$

PARAMETER		TEST CONDITIONS		MIN	TYP	MAX	UNIT
$t_{PLH}$	Propagation delay time, low-to-high-level output	$C_L = 20\text{ pF}$ ,	$R_L = 100\text{ k}\Omega$ ,		0.7	1.2	$\mu\text{s}$
$t_{PHL}$	Propagation delay time, high-to-low-level output	See Figure 1			0.3	0.8	$\mu\text{s}$

## PARAMETER MEASUREMENT INFORMATION

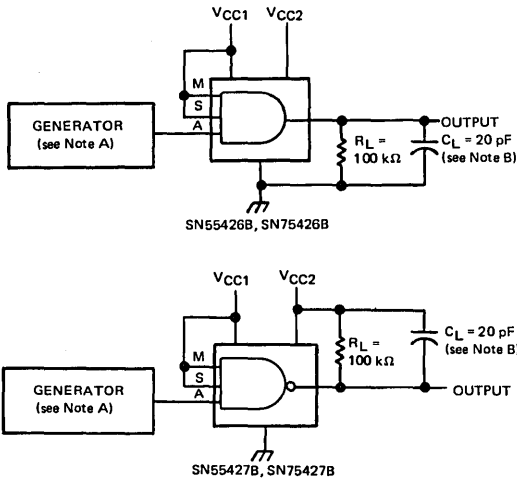

TEST CIRCUITS

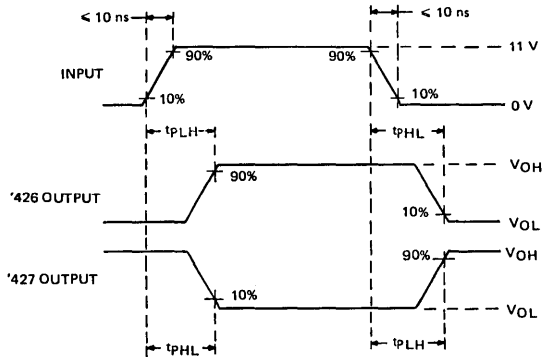

VOLTAGE WAVEFORMS

NOTES: A. The pulse generator has the following characteristics:  $Z_{out} = 50\ \Omega$ ,  $PRR = 50\text{ kHz}$ ,  $t_w = 5\ \mu\text{s}$ .  
B.  $C_L$  includes probe and jig capacitance.

FIGURE 1—SWITCHING TIMES

**TEXAS INSTRUMENTS**  
INCORPORATED

POST OFFICE BOX 225012 • DALLAS, TEXAS 75265





# INTERFACE CIRCUITS

# TYPE SN75480 HIGH-VOLTAGE 7-SEGMENT DECODER/CATHODE DRIVER

BULLETIN NO. DLS 7712244, MAY 1975—REVISED AUGUST 1977

- Plug-In Replacement for National Semiconductor DS8880<sup>†</sup>
- Adjustable Output Current from 0.2 mA to 1.5 mA
- High Off-State Output Breakdown Voltage (120 Volts Typical)
- Outputs Regulated to Ensure Constant Brightness
- Blanking and Ripple-Blanking Provisions
- Low Power Dissipation
- TTL-Compatible Inputs
- Single 5-V Supply

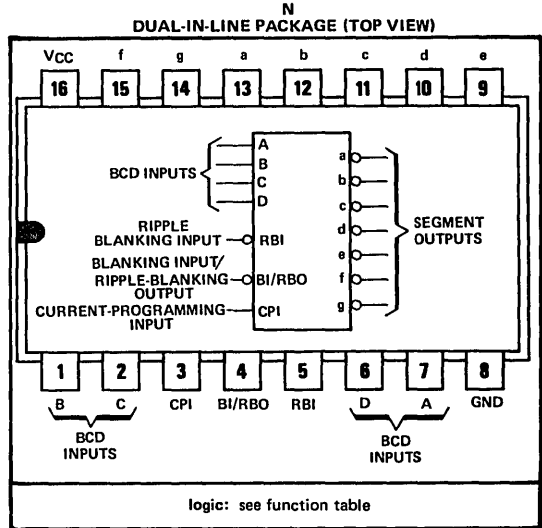

functional block diagram

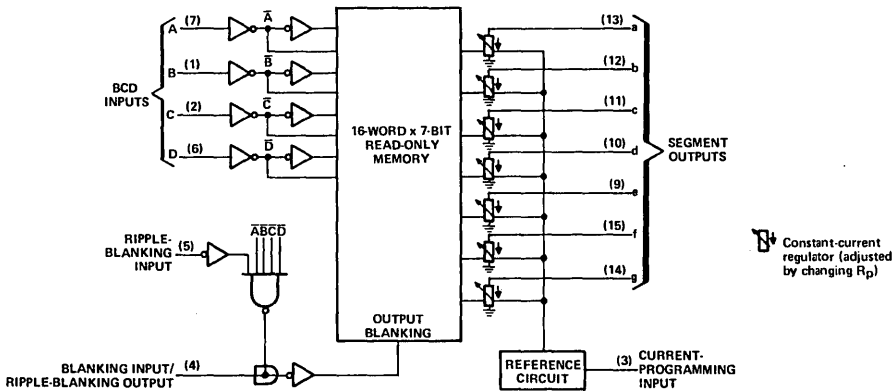

## description

The SN75480 is designed to decode four lines of BCD input and drive a gas-filled seven-segment display tube such as Beckman and Panaplex II<sup>†</sup> displays. The design employs a 112-bit read-only memory that provides BCD-input-to-full-hexadecimal decoding by switching current sinks on or off in accordance with the function table.

The output current into the current sink is adjusted by connecting an external program resistor ( $R_p$ ) from  $V_{CC}$  to the current programming input in accordance with the programming curve, Figure 1. This adjustment can vary the output sink current from nominally 0.2 milliamperes to 1.5 milliamperes in order to drive various tube types or to permit multiplex operation. The sink current for the other segments is proportioned to the b-segment current to provide even illumination of all segments. Each sink output is regulated to ensure a constant brightness of the display with a fluctuating supply voltage. Typically the on-state output current varies 1% for an output voltage change of 3 to 50 volts. The off-state voltage applied to these current sinks can vary from 3 volts to at least 80 volts.

The blanking input provides unconditional blanking of any output display, while the  $\bar{A}$  through  $\bar{D}$  inputs into the blanking circuit allow simple leading or trailing-zero blanking.

<sup>†</sup>Trademark of Burroughs Corporation.

# TYPE SN75480 HIGH-VOLTAGE 7-SEGMENT DECODER/CATHODE DRIVER

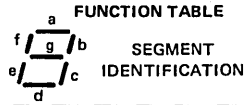

DECIMAL OR FUNCTION	INPUTS					BI/RBO	SEGMENT OUTPUTS							DISPLAY
	RBI	D	C	B	A		a	b	c	d	e	f	g	
0	H	L	L	L	L	H	ON	ON	ON	ON	ON	ON	OFF	0
1	X	L	L	L	H	H	OFF	ON	ON	OFF	OFF	OFF	OFF	1
2	X	L	L	H	L	H	ON	ON	OFF	ON	ON	OFF	ON	2
3	X	L	L	H	H	H	ON	ON	ON	ON	OFF	OFF	ON	3
4	X	L	H	L	L	H	OFF	ON	ON	OFF	OFF	ON	ON	4
5	X	L	H	L	H	H	ON	OFF	ON	ON	OFF	ON	ON	5
6	X	L	H	H	L	H	ON	OFF	ON	ON	ON	ON	ON	6
7	X	L	H	H	H	H	ON	ON	ON	OFF	OFF	OFF	OFF	7
8	X	H	L	L	L	H	ON	ON	ON	ON	ON	ON	ON	8
9	X	H	L	L	H	H	ON	ON	ON	ON	OFF	ON	ON	9
10	X	H	L	H	L	H	ON	ON	ON	OFF	ON	ON	ON	A
11	X	H	L	H	H	H	OFF	OFF	ON	ON	ON	ON	ON	b
12	X	H	H	L	L	H	ON	OFF	OFF	ON	ON	ON	OFF	c
13	X	H	H	L	H	H	OFF	ON	ON	ON	ON	OFF	ON	d
14	X	H	H	H	L	H	ON	OFF	OFF	ON	ON	ON	ON	E
15	X	H	H	H	H	H	ON	OFF	OFF	OFF	ON	ON	ON	F
BI	X	X	X	X	X	L	OFF	OFF	OFF	OFF	OFF	OFF	OFF	
RBI	L	L	L	L	L	L†	OFF	OFF	OFF	OFF	OFF	OFF	OFF	

H = high level, L = low level, X = irrelevant

†BI/RBO is wire-AND logic serving as a blanking input (BI) and/or ripple-blanking output (RBO). When RBI and inputs A, B, C, and D are all low, all segment outputs go off and RBO goes to a low-level (response condition).

9

## schematics of inputs and outputs

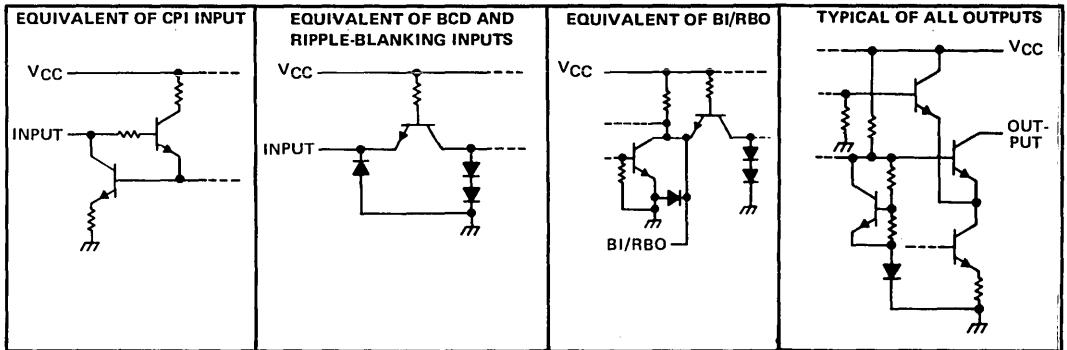

# TYPE SN75480

## HIGH-VOLTAGE 7-SEGMENT DECODER/CATHODE DRIVER

### absolute maximum ratings over operating free-air temperature range (unless otherwise noted)

Supply voltage, $V_{CC}$ (see Note 1)	7 V
Input voltage: All inputs except BI/RBO	6 V
BI/RBO	$V_{CC}$
On-state output voltage	55 V
Continuous on-state segment output current	2.3 mA
Peak transient on-state segment output current (see Note 2)	50 mA
Continuous total dissipation	600 mW
Operating free-air temperature range	$0^{\circ}\text{C}$ to $70^{\circ}\text{C}$
Storage temperature range	$-65^{\circ}\text{C}$ to $150^{\circ}\text{C}$
Lead temperature 1/16 inch from case for 10 seconds	$260^{\circ}\text{C}$

- NOTES: 1. Voltage values are with respect to network ground terminal.  
 2. In all applications, peak transient segment current must be limited to 50 mA. This may be accomplished in d-c applications by connecting a 2.2 k $\Omega$  resistor from the anode-supply filter capacitor to the display anode, or by current limiting the anode driver in multiplex applications (See Figure 4).

### recommended operating conditions

	MIN	NOM	MAX	UNIT
Supply voltage, $V_{CC}$	4.75	5	5.25	V
Off-state output voltage			80	V
On-state output voltage	3		50	V
Operating free-air temperature	0		70	$^{\circ}\text{C}$

### electrical characteristics over recommended operating free-air temperature range (unless otherwise noted)

PARAMETER		TEST CONDITIONS		MIN	TYP†	MAX	UNIT	
$V_{IH}$	High-level input voltage			2			V	
$V_{IL}$	Low-level input voltage					0.8	V	
$V_{IK}$	Input clamp voltage		$V_{CC} = 5.25\text{ V}, I_I = -12\text{ mA}, T_A = 25^{\circ}\text{C}$	-0.9		-1.5	V	
$V_{OH}$	High-level output voltage	BI/RBO	$V_{CC} = 4.75\text{ V}, I_{OH} = -200\text{ }\mu\text{A}$	2.4		3.0	V	
$V_{OL}$	Low-level output voltage	BI/RBO	$V_{CC} = 4.75\text{ V}, I_{OL} = 8\text{ mA}$		0.17	0.4	V	
$V_{(BR)off}$	Off-state output breakdown voltage	a thru g	BI/RBO at 0 V, $I_O = 250\text{ }\mu\text{A}$	80	120		V	
$I_{O(off)}$	Off-state output current	a thru g	BI/RBO at 0 V, $V_O = 75\text{ V}$		0.003	3	$\mu\text{A}$	
$I_{O(on)b}$	Segment-b on-state output current		$V_{CC} = 5\text{ V}, V_{O(b)} = 50\text{ V}, T_A = 25^{\circ}\text{C}$	$R_p = 18.1\text{ k}\Omega$	0.18	0.20	0.22	mA
				$R_p = 7.03\text{ k}\Omega$	0.45	0.50	0.55	
				$R_p = 3.4\text{ k}\Omega$	0.9	1.0	1.1	
				$R_p = 2.2\text{ k}\Omega$	1.35	1.5	1.65	
$\frac{I_{O(on)}}{I_{O(on)b}}$	Segment output currents normalized to b-segment current	Segments a, f, & g	$V_{CC} = 5\text{ V},$ All outputs at 50 V, $T_A = 25^{\circ}\text{C}$		0.84	0.93	1.02	
		Segment c			1.12	1.25	1.38	
		Segment d			0.9	1.00	1.1	
		Segment e			0.99	1.10	1.21	
$I_I$	Input current	Any input except BI/RBO	$V_{CC} = 5.25\text{ V}, V_I = 5.5\text{ V}$		7	400	$\mu\text{A}$	
$I_{IH}$	High-level input current	Any input except BI/RBO	$V_{CC} = 5.25\text{ V}, V_I = 2.4\text{ V}$		6	40	$\mu\text{A}$	
$I_{IL}$	Low-level input current	Any input except BI/RBO	$V_{CC} = 5.25\text{ V}, V_I = 0.4\text{ V}$		-0.4	-0.6	mA	
		BI/RBO			-1.5	-2		
$I_{CC}$	Supply current		$V_{CC} = 5.25\text{ V},$ All inputs at 0 V, $R_p = 2.2\text{ k}\Omega$		27	43	mA	

† All typical values are at  $V_{CC} = 5\text{ V}, T_A = 25^{\circ}\text{C}$ .

9

# TYPE SN75480 HIGH-VOLTAGE 7-SEGMENT DECODER/CATHODE DRIVER

switching characteristics,  $V_{CC} = 5\text{ V}$ ,  $T_A = 25^\circ\text{C}$

PARAMETER	MIN	TYP	MAX	UNIT
$t_{off}$ Turn-off time of segment outputs from BCD inputs		0.4	10	$\mu\text{S}$
$t_{on}$ Turn-on time of segment outputs from BCD inputs		0.4	10	
$t_{off}$ Turn-off time of segment outputs from BI/RBO		0.4	10	$\mu\text{S}$
$t_{on}$ Turn-on time of segment outputs from BI/RBO		0.4	10	
$t_{off}$ Turn-off time of segment outputs from RBI		0.4	10	$\mu\text{S}$
$t_{on}$ Turn-on time of segment outputs from RBI		0.7	10	
$t_{PLH}$ Propagation delay time, low-to-high-level RBO from RBI		0.4	10	$\mu\text{S}$
$t_{PHL}$ Propagation delay time, high-to-low-level RBO from RBI		0.4	10	

## TYPICAL CHARACTERISTICS

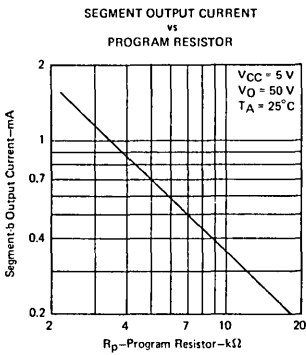

FIGURE 1

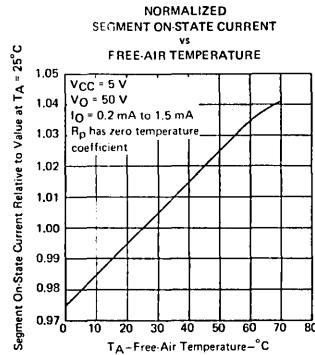

FIGURE 2

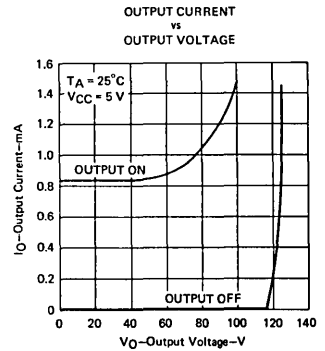

FIGURE 3

## TYPICAL APPLICATION DATA

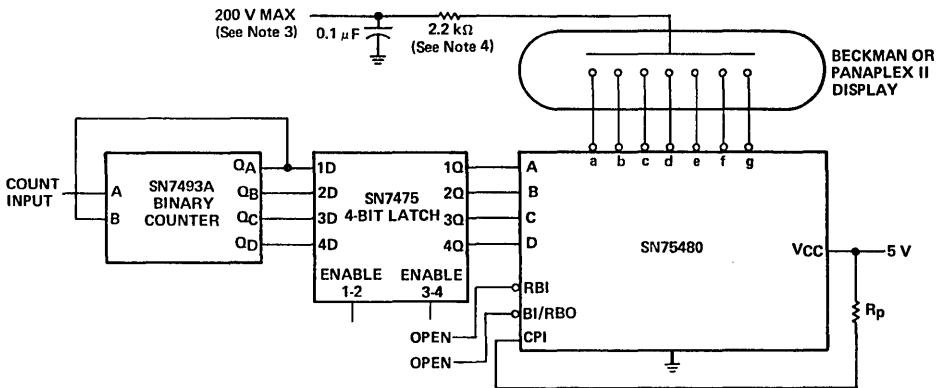

FIGURE 4—HEXADECIMAL DISPLAY

- NOTES:
- This voltage must be adjusted for the type of display used to ensure that the on-state and off-state voltages do not exceed 55 V and 80 V, respectively, at the outputs of the SN75480.
  - In all applications, peak transient segment current must be limited to 50 mA. This may be accomplished in d-c applications by connecting a 2.2-k $\Omega$  resistor from the anode-supply filter capacitor to the display anode, or by current limiting the anode driver in multiplex applications.

# INTERFACE CIRCUITS

# TYPE SN75481 ANODE DRIVERS FOR GAS DISCHARGE DISPLAYS

BULLETIN NO. DL-S 7512514, APRIL 1975

- MOS-Compatible Inputs
- Designed for Use with Panaplex II<sup>†</sup> Displays
- 55-Volt Operation
- 13-mA Output Capability

## description

The SN75481 is a hex digit driver designed to be used as an anode driver for Panaplex II<sup>†</sup> gas discharge displays. The guaranteed 55-volt minimum breakdown voltage, MOS compatible inputs, and six drivers per package make it ideally suited for time-multiplexed calculator displays.

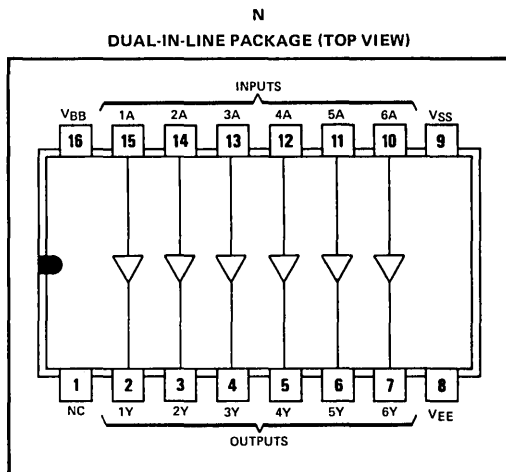

NC—No internal connection.

When the input is open or low ( $\approx V_{BB}$ ), the output will be off and at approximately  $V_{EE}$ . When the input is high ( $\approx V_{SS}$ ), the output will be on and at approximately  $V_{SS}-2$  volts. Each output is designed to supply up to 13 milliamperes when in the on state.

The SN75481 is characterized for operation from  $0^{\circ}\text{C}$  to  $70^{\circ}\text{C}$ .

## schematic (each driver)

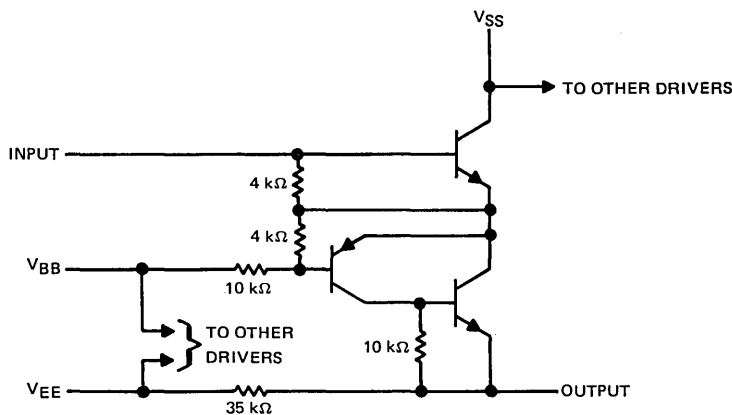

<sup>†</sup>Trademark of Burroughs Corporation.

# TYPE SN75481

## ANODE DRIVERS FOR GAS DISCHARGE DISPLAYS

absolute maximum ratings over operating free-air temperature range (unless otherwise noted)

Supply voltage, $V_{BB}$ (see Note 1)	-25 V
Supply voltage, $V_{EE}$	-60 V
Input voltage	$V_{BB}$
Continuous output current	-20 mA
Continuous total dissipation at (or below) 25°C free-air temperature (see Note 2)	800 mW
Operating free-air temperature range	0°C to 70°C
Storage temperature range	-65°C to 150°C
Lead temperature 1/16 inch from case for 10 seconds	260°C

NOTES: 1. All voltage values are with respect to  $V_{SS}$ .

2. For operation above 25°C free-air temperature, refer to Dissipation Derating Curves in the Thermal Information Section, which starts on page 2-1.

electrical characteristics over recommended operating free-air temperature range,  
 $V_{SS} = 0$ ,  $V_{BB} = -18$  V,  $V_{EE} = -55$  V (unless otherwise noted)

PARAMETER	TEST CONDITIONS	MIN	TYP	MAX	UNIT
$V_{O(on)}$ On-state output voltage	$V_I = V_{SS}$ thru 1 k $\Omega$ , $V_{BB} = -9$ V, $I_O = -12$ mA	0	-3.5		V
$V_{O(off)}$ Off-State output voltage	$I_{IL} = 100$ $\mu$ A, $V_{BB} = -9$ V, $I_O = 0$	-53		-55	V
$I_{IH}$ High-level input current	$V_I = V_{SS}$ thru 100 $\Omega$ , $I_O = -12$ mA			1.5	mA
$I_{BB}$ Supply current from $V_{BB}$	One input to $V_{SS}$ thru 100 $\Omega$ , All other inputs open, $I_O = -12$ mA			-3.5	mA
$I_{EE}$ Supply current from $V_{EE}$	One input to $V_{SS}$ thru 100 $\Omega$ , All other inputs and all outputs open			-3	mA
$I_{SS}$ Supply current from $V_{SS}$	One input to $V_{SS}$ thru 1 k $\Omega$ , All other inputs open, $I_O = -12$ mA			20	mA

# TYPE SN75481 ANODE DRIVERS FOR GAS DISCHARGE DISPLAYS

## TYPICAL CHARACTERISTICS

OUTPUT VOLTAGE  
vs  
INPUT VOLTAGE

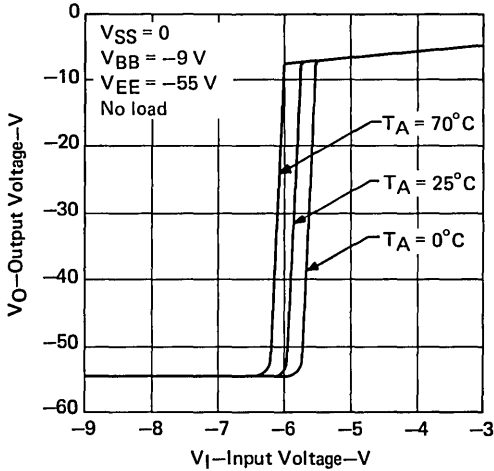

FIGURE 1

OUTPUT VOLTAGE  
vs  
INPUT VOLTAGE

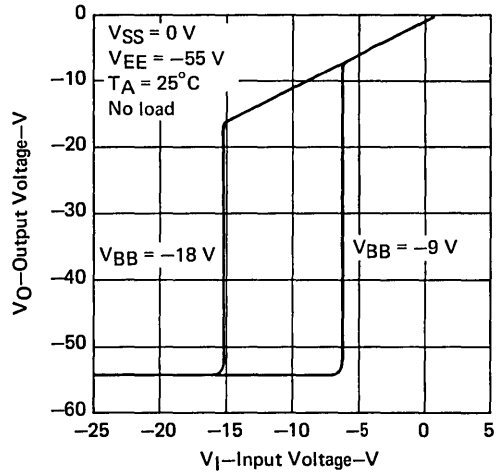

FIGURE 2

OUTPUT VOLTAGE  
vs  
INPUT CURRENT

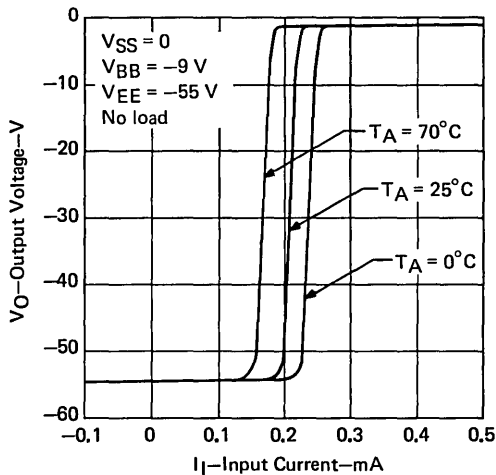

FIGURE 3

ON-STATE OUTPUT VOLTAGE  
vs  
OUTPUT CURRENT

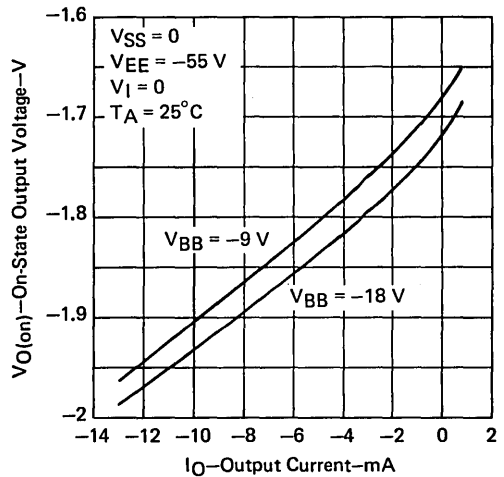
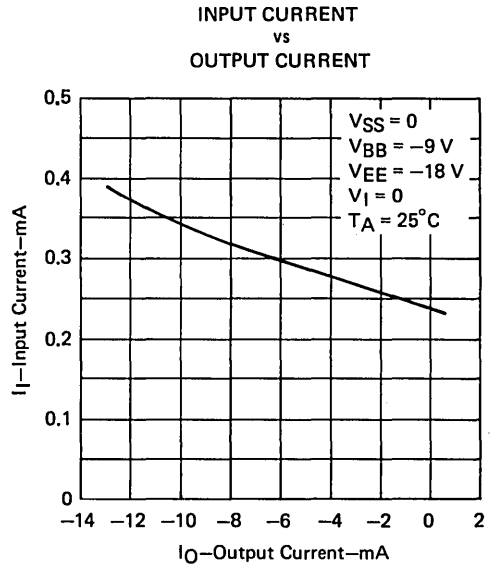
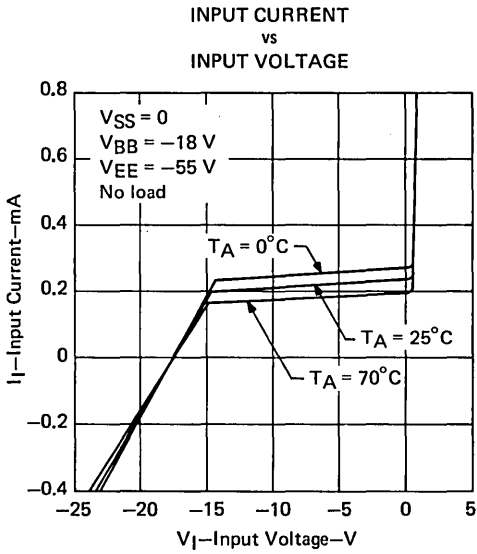

FIGURE 4

9

# TYPE SN75481 ANODE DRIVERS FOR GAS DISCHARGE DISPLAYS

## TYPICAL CHARACTERISTICS



## TYPICAL APPLICATION DATA

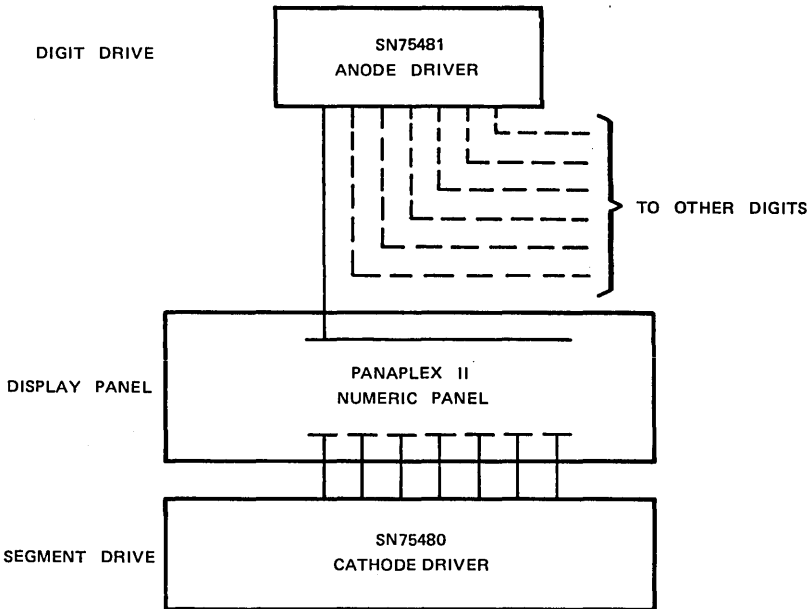



# INTERFACE CIRCUITS

# TYPE SN75490 THERMAL PRINTHEAD DRIVER

BULLETIN NO. DL-S 7712513, MAY 1977

- Inputs Compatible with TTL and 5-V CMOS
- 30-mA Source Current Capability
- 50-mA Sink Current Capability
- Standard Supply Voltages . . .  $\pm 5$  V
- Six Positive-AND Drivers per Package
- Common Strobe

### description

These circuits are designed to drive many of the popular thermal printheads including the EPN5200 and EPN3620. The SN75490 features six AND drivers with common strobe. Each driver has a totem-pole output with a nominal voltage range of  $-4.75$  V to  $3.5$  V.

The SN75490 is characterized for operation from  $0^{\circ}\text{C}$  to  $70^{\circ}\text{C}$ .

### schematic (each driver)

JOR N  
DUAL-IN-LINE PACKAGE  
(TOP VIEW)

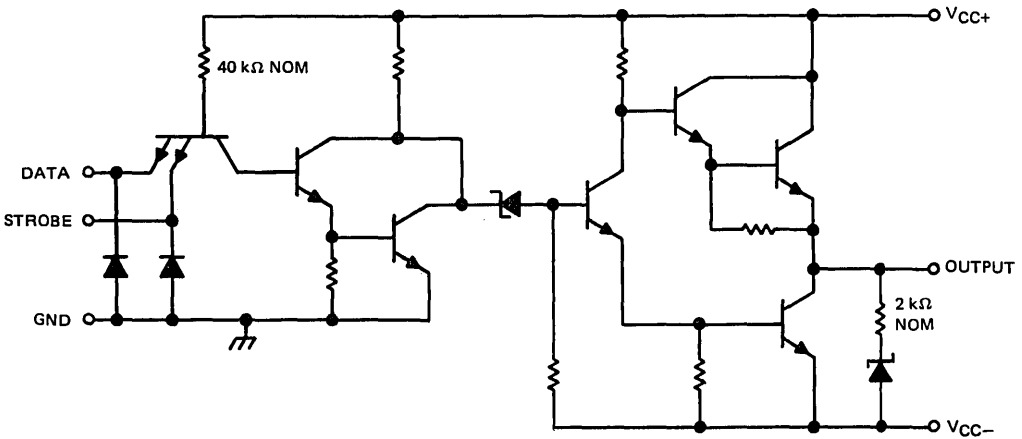
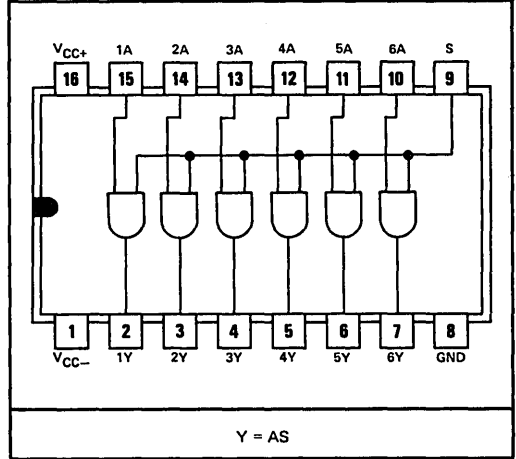

# TYPE SN75490

## THERMAL PRINTHEAD DRIVER

### absolute maximum ratings over operating free-air temperature range (unless otherwise noted)

Supply voltage, $V_{CC+}$ (see Note 1)	7 V
Supply voltage, $V_{CC-}$ (see Note 1)	-7 V
High-level output current	-40 mA
Low-level output current	60 mA
Input voltage	5.25 V
Continuous total dissipation at (or below) 25°C free-air temperature (see Note 2)	1 W
Operating free-air temperature range	0°C to 70°C
Storage temperature range	-65°C to 150°C
Lead temperature 1/16 inch from case for 60 seconds: J package	300°C
Lead temperature 1/16 inch from case for 10 seconds: N package	260°C

- NOTES: 1. Voltage values are with respect to network ground terminal.  
 2. For operation above 25°C free-air temperature, refer to the Dissipation Derating Curves in the Thermal Information section, which begins on page 2-1. In the J package, SN75490 chips are glass-mounted.

### recommended operating conditions

	MIN	NOM	MAX	UNIT
Supply voltage, $V_{CC+}$	4.75	5	5.25	V
Supply voltage, $V_{CC-}$	-4.75	-5	-5.25	V
High-level output current, $I_{OH}$			-30	mA
Low-level output current, $I_{OL}$			50	mA
Operating free-air temperature, $T_A$	0		70	°C

### electrical characteristics over recommended operating free-air temperature range, $V_{CC\pm} = \pm 5$ V (unless otherwise noted)

PARAMETER		TEST CONDITIONS		MIN	TYP <sup>†</sup>	MAX	UNIT
$V_{IH}$	High-level input voltage			2			V
$V_{IL}$	Low-level input voltage					0.7	V
$V_{IK}$	Input clamp voltage	$V_{CC+} = 4.75$ V, $I_I = -12$ mA				-1.5	V
$V_{OH}$	High-level output voltage	$V_{IH} = 2$ V	$V_{CC+} = 4.75$ V, $I_{OH} = -30$ mA	2.75			V
			$V_{CC+} = 5$ V, $I_{OH} = -30$ mA	3	3.5		
$V_{OL}$	Low-level output voltage (see Note 3)	$V_{IL} = 0.7$ V	$V_{CC-} = -4.75$ V, $I_{OL} = 50$ mA			-4.15	V
			$V_{CC-} = -5$ V, $I_{OL} = 50$ mA			-4.75	
$I_{IH}$	High-level input current	A inputs	$V_I = 5$ V			0.05	mA
		S input				0.3	
$I_{IL}$	Low-level input current	A inputs	$V_I = 0.4$ V			-0.18	mA
		S input				-1.1	
$I_{CC+(H)}$	Supply current from $V_{CC+}$ , all outputs high	$V_{CC\pm} = \pm 5.25$ V, $V_I = 5$ V			30	43	mA
$I_{CC-(H)}$	Supply current from $V_{CC-}$ , all outputs high				-6.5	-10	
$I_{CC+(L)}$	Supply current from $V_{CC+}$ , all outputs low	$V_{CC\pm} = \pm 5.25$ V, $V_I = 0.4$ V			40	58	mA
$I_{CC-(L)}$	Supply current from $V_{CC-}$ , all outputs low				-40	-58	

<sup>†</sup>All typical values are at  $V_{CC\pm} = \pm 5$  V,  $T_A = 25^\circ$  C.

NOTE 3: The algebraic convention where the more positive (less negative) limit is designated as maximum is used in this data sheet for logic voltage levels only, e.g., if -4.4 V is a maximum, the typical value is a more negative voltage.

# TYPE SN75490 THERMAL PRINTHEAD DRIVER

switching characteristics,  $V_{CC\pm} = \pm 5 \text{ V}$ ,  $T_A = 25^\circ \text{ C}$

PARAMETER	TEST CONDITIONS	MIN	TYP	MAX	UNIT	
$t_{PLH}$ Propagation delay time, low-to-high-level output	$C_L = 15 \text{ pF}$ , $R_L = 120 \Omega$ , See Figure 1		50		ns	
$t_{PHL}$ Propagation delay time, high-to-low-level output			50		ns	
$t_{TLH}$ Transition time, low-to-high-level output				8		ns
$t_{THL}$ Transition time, high-to-low-level output				8		ns

## PARAMETER MEASUREMENT INFORMATION

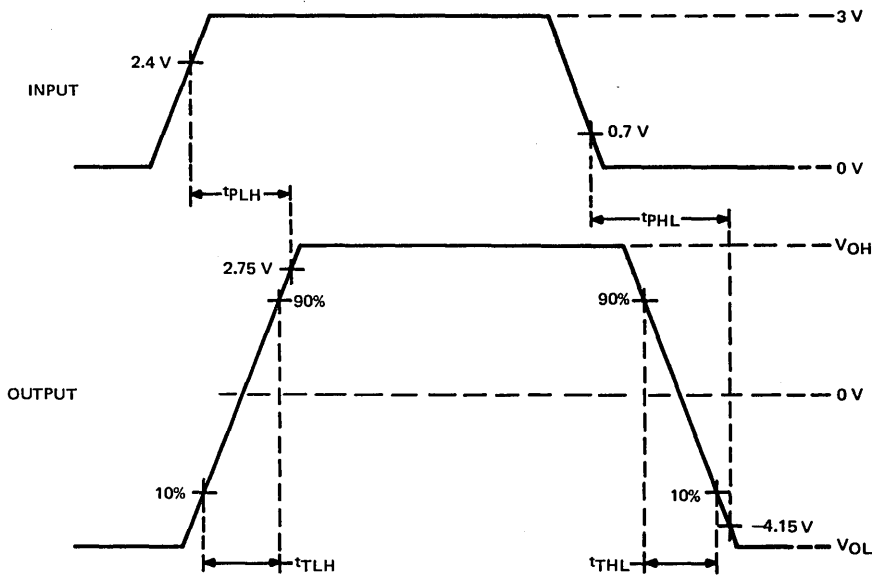
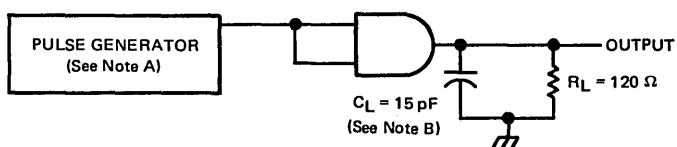

NOTES: A. The pulse generator has the following characteristics:  $Z_{out} = 50 \Omega$ ,  $f = 100 \text{ kHz}$ ,  $t_w = 1 \mu\text{s}$ ,  $t_r < 10 \text{ ns}$ ,  $t_f < 10 \text{ ns}$ .  
B.  $C_L$  includes probe and jig capacitance.

FIGURE 1—SWITCHING TIMES

**TEXAS INSTRUMENTS**  
INCORPORATED

POST OFFICE BOX 225012 • DALLAS, TEXAS 75265

# TYPE SN75490 THERMAL PRINTHEAD DRIVER

## TYPICAL APPLICATION DATA

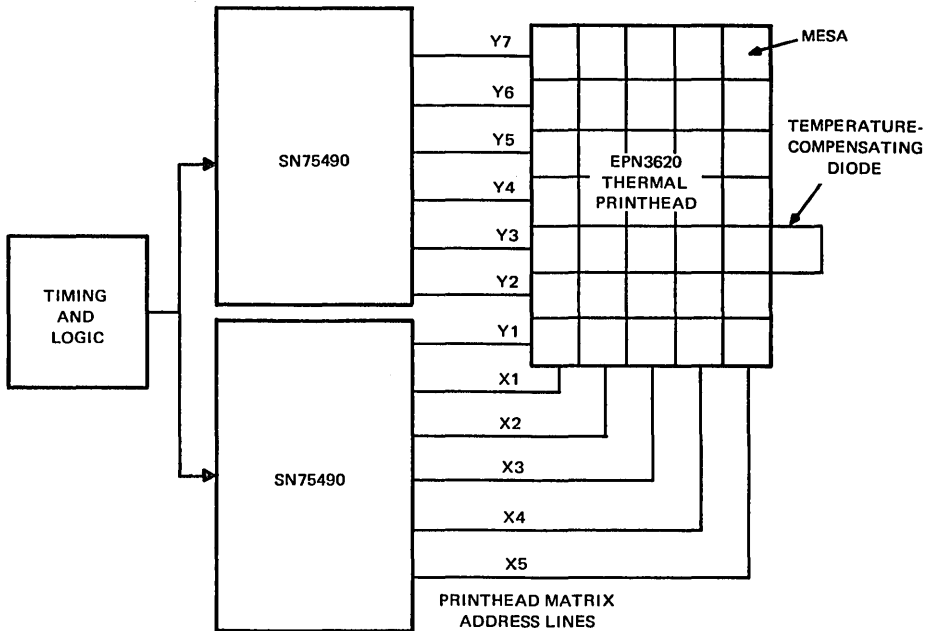

FIGURE 2—PRINTER SYSTEM BLOCK DIAGRAM USING SN75490 DRIVERS AND EPN3620 THERMAL PRINTHEAD

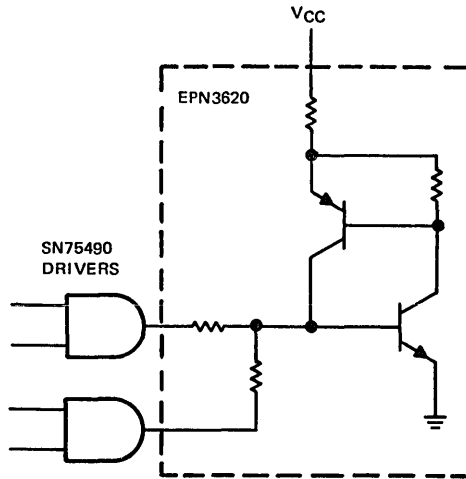

FIGURE 3—DIAGRAM SHOWING THE CONNECTION WITH ONE OF THE MESAS OF THE EPN3620

For a detailed description of the EPN3620 thermal printhead, see data sheet DL-S 7712505 and Texas Instruments Application Report, Bulletin CA-190.

# INTERFACE CIRCUITS

# TYPES SN75491, SN75491A, SN75492, SN75492A MOS-TO-LED DRIVERS

BULLETIN NO. DL-S 7711769, OCTOBER 1972—REVISED MAY 1977

## QUAD SEGMENT DRIVER AND HEX DIGIT DRIVER FOR INTERFACING BETWEEN MOS AND LIGHT-EMITTING-DIODE (LED) DISPLAYS

SN75491, SN75491A  
N DUAL-IN-LINE PACKAGE (TOP VIEW)

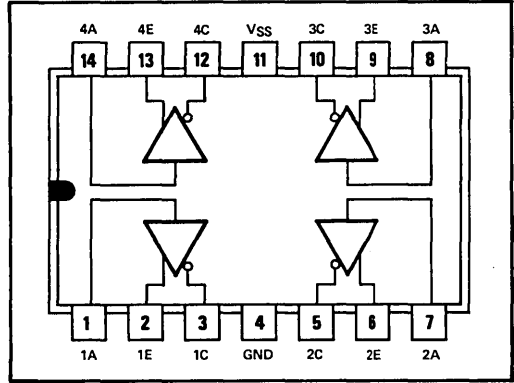

- 50-mA Source or Sink Capability ('491, '491A)
- 250-mA Sink Capability ('492, '492A)
- Rated for 10-V Operation ('491, '492)
- Rated for 20-V Operation ('491A, '492A)
- Low Input Current for MOS Compatibility
- Low Standby Power
- High-Gain Darlington Circuits

### description

The SN75491, SN75491A, SN75492, and SN75492A are monolithic integrated circuits designed to be used together with MOS integrated circuits and common-cathode LED's in serially addressed multi-digit displays. This time-multiplexed system, which uses a segment-address-and-digit-scan method of LED drive, minimizes the number of drivers required.

The SN75491 and SN75491A are quadruple segment drivers. The SN75492 and SN75492A are hex digit drivers. The SN75491 and SN75492 are characterized for operation to 10 volts. The SN75491A and SN75492A are characterized for operation to 20 volts.

SN75492, SN75492A  
N DUAL-IN-LINE PACKAGE (TOP VIEW)

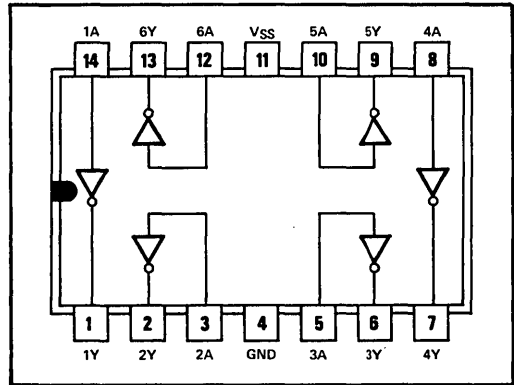

### schematic

SN75491, SN75491A (each driver)

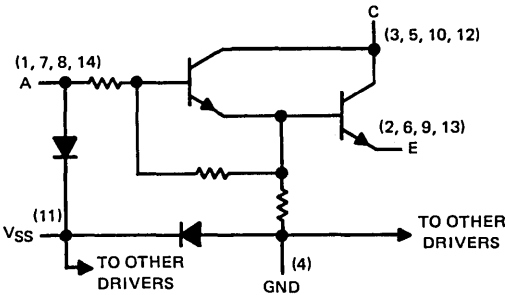

SN75492, SN75492A (each driver)

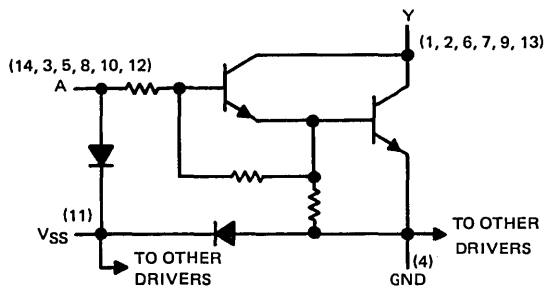

# TYPES SN75491, SN75491A, SN75492, SN75492A

## MOS-TO-LED DRIVERS

absolute maximum ratings over operating free-air temperature range (unless otherwise noted)

	SN75491	SN75491A	SN75492	SN75492A	UNIT	
Input voltage range (see Note 1)	-5 to $V_{SS}$	-5 to $V_{SS}$	-5 to $V_{SS}$	-5 to $V_{SS}$	V	
Collector (output) voltage (see Note 2)	10	20	10	20	V	
Collector (output)-to-input voltage	10	20	10	20	V	
Emitter-to-ground voltage ( $V_I > 5$ V)	10	20			V	
Emitter-to-input voltage	5	5			V	
Voltage at $V_{SS}$ terminal with respect to any other device terminal	10	20	10	20	V	
Collector (output) current	each collector (output)	50	50	250	250	mA
	all collectors (outputs)	200	200	600	600	
Continuous total dissipation at (or below) 25°C free-air temperature (see Note 3)	800	800	800	800	mW	
Operating free-air temperature range	0 to 70	0 to 70	0 to 70	0 to 70	°C	
Storage temperature range	-65 to 150	-65 to 150	-65 to 150	-65 to 150	°C	
Lead temperature 1/16 inch from case for 10 seconds	260	260	260	260	°C	

- NOTES: 1. The input is the only device terminal that may be negative with respect to ground.  
 2. Voltage values are with respect to network ground terminal unless otherwise noted.  
 3. For operation above 25°C free-air temperature, refer to Dissipation Derating Curves in the Thermal Information section, which starts on page 2-1.

'491, '491A electrical characteristics,  $V_{SS} = 10$  V for SN75491,  $V_{SS} = 20$  V for SN75491A,  $T_A = 0^\circ\text{C}$  to  $70^\circ\text{C}$  (unless otherwise noted)

PARAMETER	TEST CONDITIONS	MIN	TYP†	MAX	UNIT
$V_{CE(on)}$ On-state collector-emitter voltage	Input = 8.5 V through 1 k $\Omega$ , $V_E = 5$ V, $I_C = 50$ mA, $T_A = 25^\circ\text{C}$		0.9	1.2	V
	Input = 8.5 V through 1 k $\Omega$ , $V_E = 5$ V, $I_C = 50$ mA			1.5	
$I_{C(off)}$ Off-state collector current	$V_C = V_{SS}$ , $V_E = 0$ , $I_I = 40$ $\mu\text{A}$			100	$\mu\text{A}$
	$V_C = V_{SS}$ , $V_E = 0$ , $V_I = 0.7$ V			100	
$I_I$ Input current at maximum input voltage	$V_I = V_{SS}$ , $V_E = 0$ , $I_C = 20$ mA	'491	2.2	3.3	mA
		'491A	4.7	6.5	
$I_E$ Emitter reverse current	$V_I = 0$ , $V_E = 5$ V, $I_C = 0$			100	$\mu\text{A}$
$I_{SS}$ Current into $V_{SS}$ terminal				1	mA

'492, '492A electrical characteristics,  $V_{SS} = 10$  V for SN75492,  $V_{SS} = 20$  V for SN75492A,  $T_A = 0^\circ\text{C}$  to  $70^\circ\text{C}$  (unless otherwise noted)

PARAMETER	TEST CONDITIONS	MIN	TYP†	MAX	UNIT
$V_{OL}$ Low-level output voltage	Input = 6.5 V through 1 k $\Omega$ , $I_{OL} = 250$ mA, $T_A = 25^\circ\text{C}$		0.9	1.2	V
	Input = 6.5 V through 1 k $\Omega$ , $I_{OL} = 250$ mA			1.5	
$I_{OH}$ High-level output current	$V_{OH} = V_{SS}$ , $I_I = 40$ $\mu\text{A}$			200	$\mu\text{A}$
	$V_{OH} = V_{SS}$ , $V_I = 0.5$ V			200	
$I_I$ Input current at maximum input voltage	$V_I = V_{SS}$ , $I_{OL} = 20$ mA	'492	2.2	3.3	mA
		'492A	4.7	6.5	
$I_{SS}$ Current into $V_{SS}$ terminal				1	mA

† All typical values are at  $T_A = 25^\circ\text{C}$

# TYPES SN75491, SN75491A, SN75492, SN75492A MOS-TO-LED DRIVERS

SN75491, SN75491A switching characteristics,  $V_{SS} = 7.5 \text{ V}$ ,  $T_A = 25^\circ \text{C}$

PARAMETER	TEST CONDITIONS	MIN	TYP	MAX	UNIT
$t_{pLH}$ Propagation delay time, low-to-high-level output (collector)	$V_{IH} = 4.5 \text{ V}$ , $V_E = 0$ ,		100		ns
$t_{pHL}$ Propagation delay time, high-to-low-level output (collector)	$R_L = 200 \Omega$ , $C_L = 15 \text{ pF}$	20			ns

SN75492, SN75492A switching characteristics,  $V_{SS} = 7.5 \text{ V}$ ,  $T_A = 25^\circ \text{C}$

PARAMETER	TEST CONDITIONS	MIN	TYP	MAX	UNIT
$t_{pLH}$ Propagation delay time, low-to-high-level output	$V_{IH} = 7.5 \text{ V}$ , $R_L = 39 \Omega$ ,		300		ns
$t_{pHL}$ Propagation delay time, high-to-low-level output	$C_L = 15 \text{ pF}$	30			ns

## PARAMETER MEASUREMENT INFORMATION

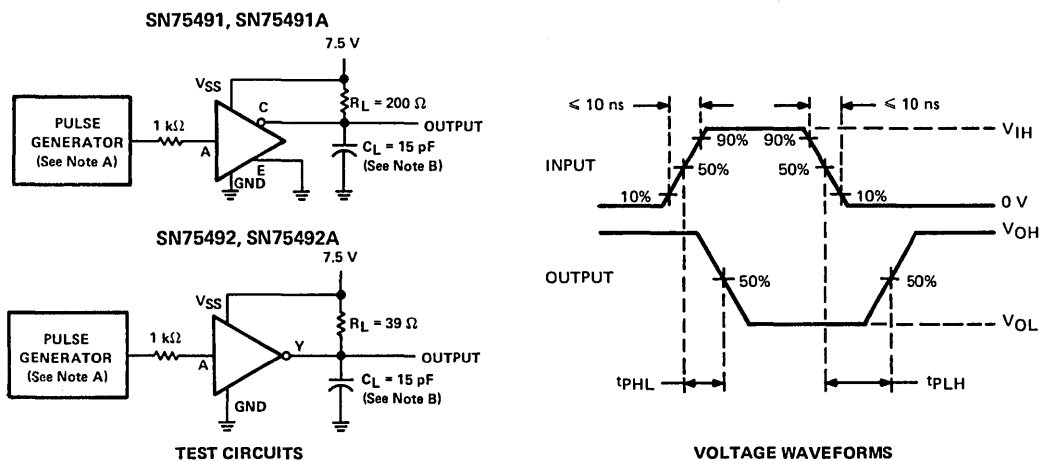

NOTES: A. The pulse generator has the following characteristics:  $Z_{out} = 50 \Omega$ ,  $PRR = 100 \text{ kHz}$ ,  $t_w = 1 \mu\text{s}$ .  
 B.  $C_L$  includes probe and jig capacitance.

FIGURE 1—PROPAGATION DELAY TIMES

## TYPICAL CHARACTERISTICS

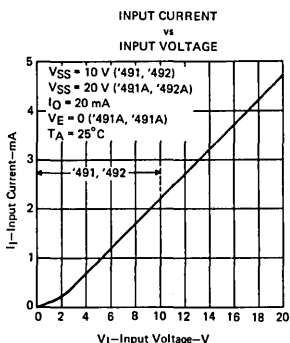

FIGURE 2

# TYPES SN75491, SN75491A, SN75492, SN75492A MOS-TO-LED DRIVERS

## TYPICAL CHARACTERISTICS

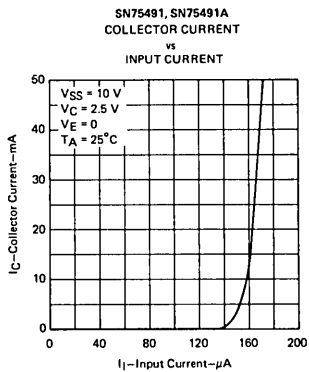

FIGURE 3

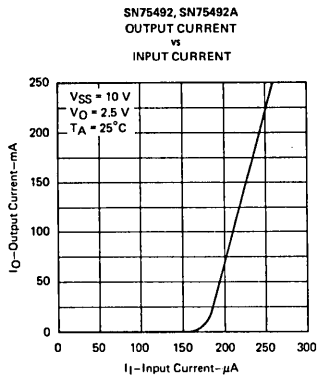

FIGURE 4

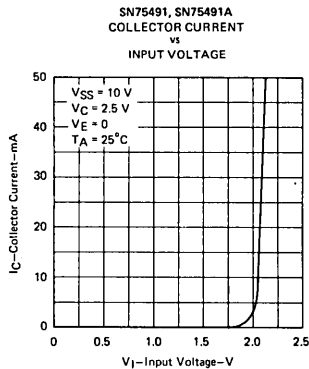

FIGURE 5

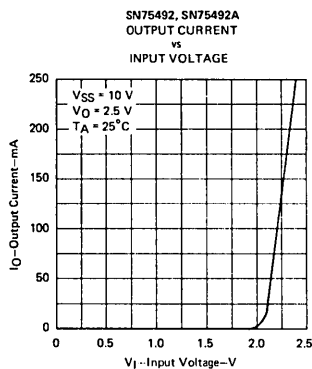

FIGURE 6

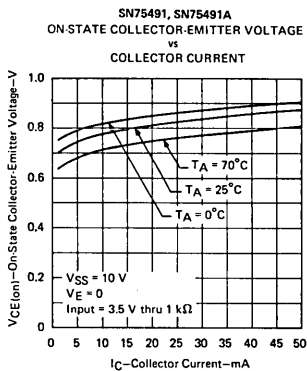

FIGURE 7

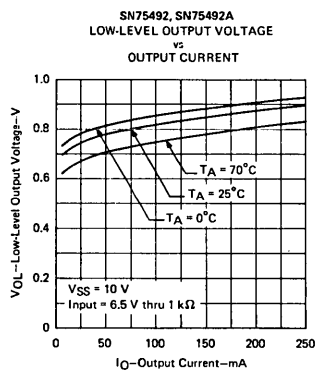

FIGURE 8



# TYPES SN75491, SN75491A, SN75492, SN75492A MOS-TO-LED DRIVERS

## TYPICAL APPLICATION DATA

Figure 9 is an example of time multiplexing the individual digits in a visible display to minimize display circuitry. Up to twelve digits, each of which use a seven-segment display with decimal point, may be displayed using only two SN75491 and two SN75492 drivers.

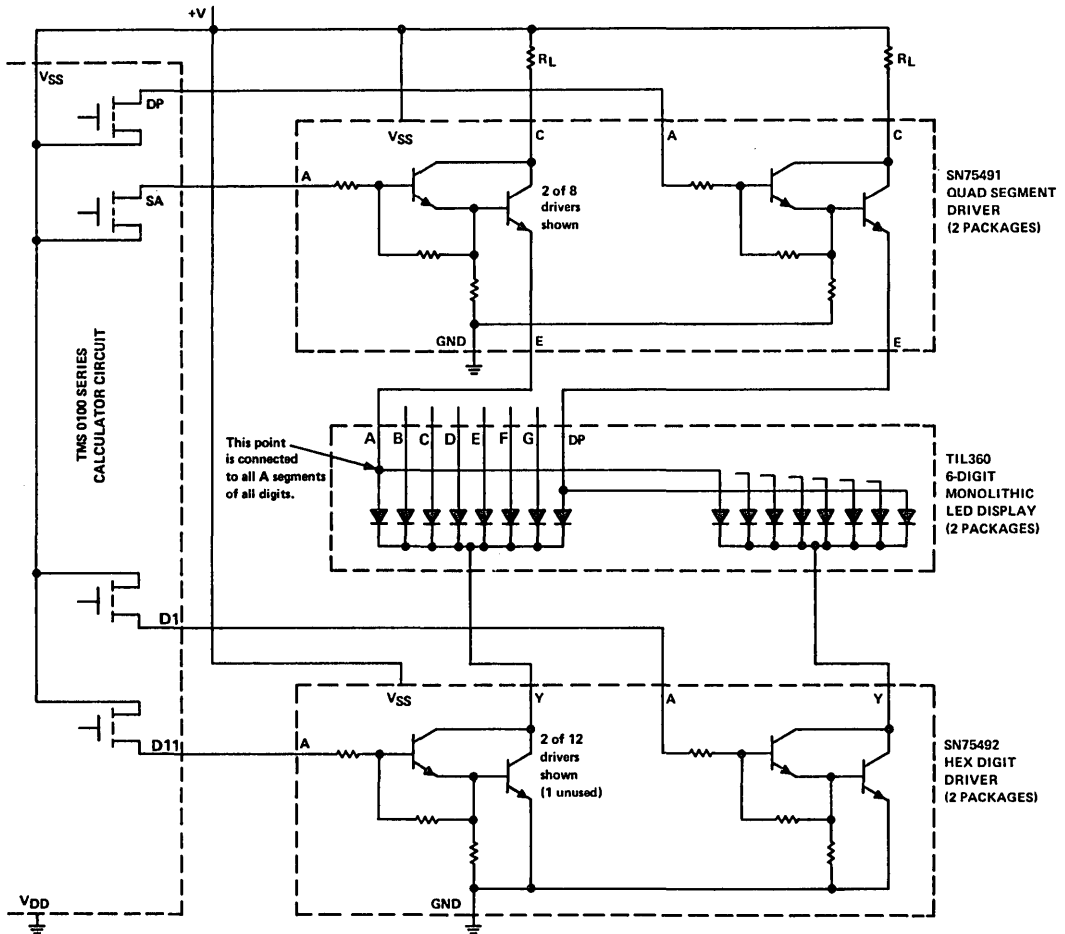

FIGURE 9—INTERFACING BETWEEN MOS CALCULATOR CIRCUIT AND LED MULTI-DIGIT DISPLAY

# TYPES SN75491, SN75491A, SN75492, SN75492A MOS-TO-LED DRIVERS

## TYPICAL APPLICATION DATA

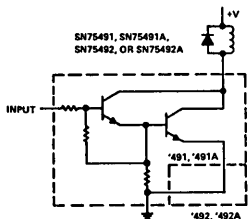

FIGURE 10—QUAD OR HEX RELAY DRIVER

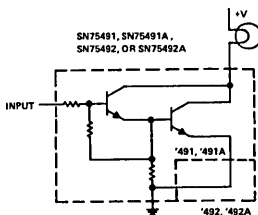

FIGURE 11—QUAD OR HEX LAMP DRIVER

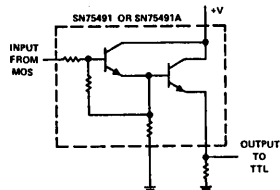

FIGURE 12—MOS-TO-TTL LEVEL SHIFTER

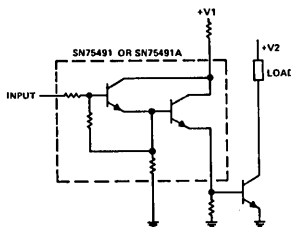
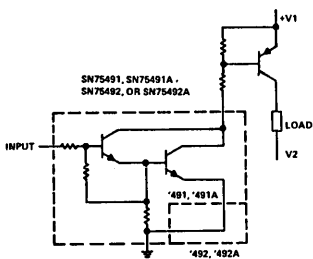

FIGURE 13—QUAD HIGH-CURRENT N-P-N TRANSISTOR DRIVER



NOTE A: This circuit may be used as a digit driver for common-anode LED displays.

FIGURE 14—QUAD OR HEX HIGH-CURRENT P-N-P TRANSISTOR DRIVER

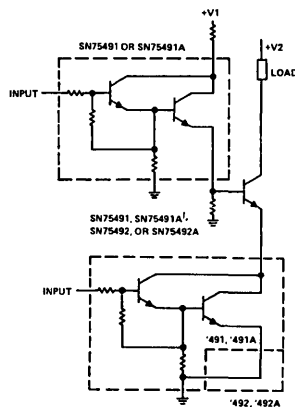

FIGURE 15—BASE/EMITTER SELECT N-P-N TRANSISTOR DRIVER

# TYPES SN75491, SN75491A, SN75492, SN75492A MOS-TO-LED DRIVERS

## TYPICAL APPLICATION DATA

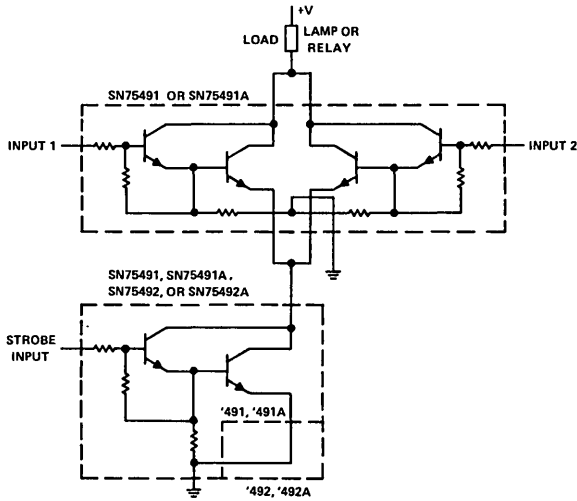

FIGURE 16—STROBED "NOR" DRIVER

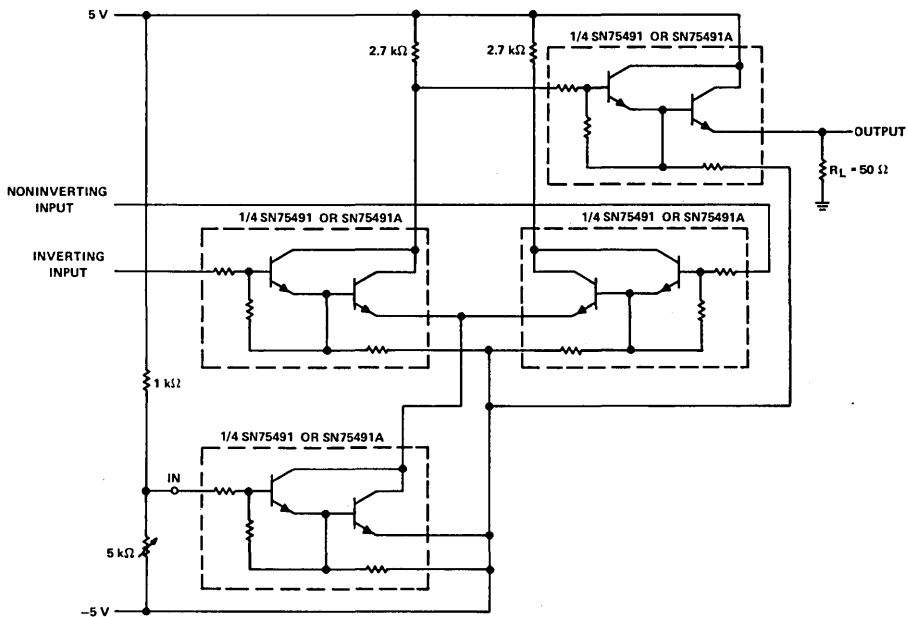

FIGURE 17—SN75491/SN75491A USED AS AN INTERFACE CIRCUIT BETWEEN THE BALANCED 30-MHz OUTPUT OF AN RF AMPLIFIER AND A COAXIAL CABLE



# INTERFACE CIRCUITS

# TYPES SN75493, SN75494 MOS-TO-LED SEGMENT AND DIGIT DRIVERS

BULLETIN NO. DL-S 7712454, MAY 1977

- Low Input Current for MOS Compatibility
- Low-Voltage Operation
- Low Standby Power
- Display Blanking Capability

### additional SN75493 features

- 50-mA Source Capability
- Output Current Regulation
- Quad High-Gain Circuits

### additional SN75494 features

- 250-mA Sink Capability
- Low-Voltage Saturating Outputs
- Hex High-Gain Circuits

### description

The SN75493 and SN75494 are designed to be used to interface between MOS integrated circuits and LEDs in serially addressed multidigit displays. These two devices are similar in operation to the SN75491 and SN75492, but have several advantages over those earlier circuits. The SN75493 and SN75494 can be operated at lower supply voltages and, therefore, reduce power consumption. The SN75493 is designed to give relatively constant current through an external resistor, independent of supply voltage. The enable ( $\bar{E}$ ) pin of each circuit is intended for use as a blanking input.

SN75493  
N DUAL-IN-LINE PACKAGE (TOP VIEW)

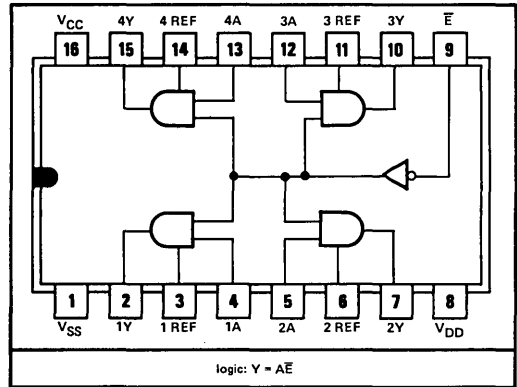

SN75494  
N-DUAL-IN-LINE PACKAGE (TOP VIEW)

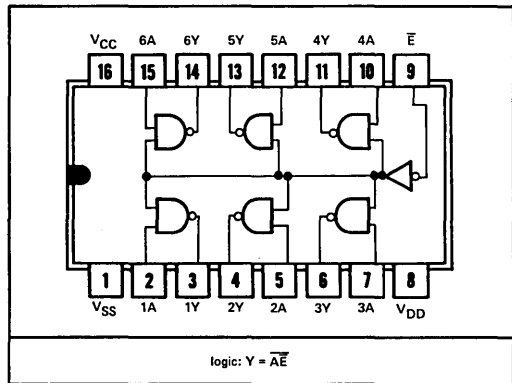

# TYPES SN75493, SN75494 MOS-TO-LED SEGMENT AND DIGIT DRIVERS

schematics

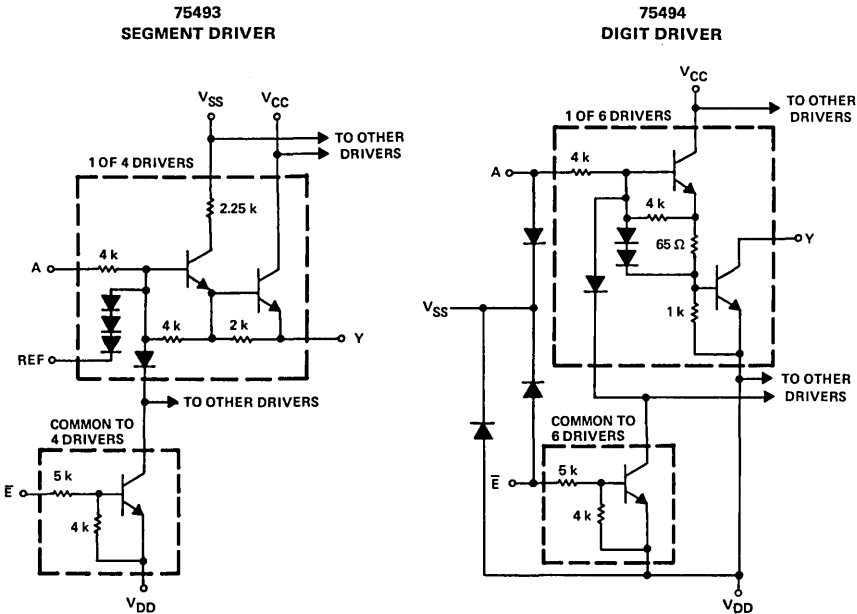

NOTES: A. The  $V_{SS}$  terminal of the SN75494 must be connected to the most positive voltage that is applied to the device.  
B. Resistor values shown are nominal and in ohms.

## absolute maximum ratings over operating free-air temperature range (unless otherwise noted)

	SN75493	SN75494	UNITS
Supply voltage, $V_{CC}$ (see Note 1)	10	10	V
Supply voltage, $V_{SS}$	10	10	V
Input voltage	$V_{SS}$	$V_{SS}$	V
Off-state output voltage		10	V
Input-to-reference voltage	8.8		V
Continuous output current (each driver)	50	250	mA
Continuous $V_{DD}$ current		600	mA
Continuous total dissipation at (or below) 25°C free-air temperature (see Note 2)	800	800	mW
Operating free-air temperature range	0 to 70	0 to 70	°C
Storage temperature range	-65 to 150	-65 to 150	°C
Lead temperature 1/16 inch from case for 10 seconds	260	260	°C

NOTES: 1. All voltage values are with respect to the most negative device terminal,  $V_{DD}$ , unless otherwise noted.  
2. For operation above 25°C free-air temperature, refer to Dissipation Derating Curves in the Thermal Information section, which starts on page 2-1.

## recommended operating conditions

	MIN	MAX	UNIT
Supply voltage, $V_{CC}$	3.2	8.8	V
Supply voltage, $V_{SS}$	6.5	8.8	V
Operating free-air temperature, $T_A$	0	70	°C

# TYPES SN75493, SN75494 MOS-TO-LED SEGMENT AND DIGIT DRIVERS

SN75493 electrical characteristics,  $V_{CC} = 8.8 \text{ V}$ ,  $V_{SS} = 8.8 \text{ V}$ ,  $T_A = 0^\circ\text{C}$  to  $70^\circ\text{C}$  (unless otherwise noted)

PARAMETER		TEST CONDITIONS		MIN	TYP†	MAX	UNIT
$I_I$	Input current	A input	A at 8.8 V, REF at 0 V, Y to 0 V thru 50 $\Omega$	$\bar{E}$ at 0 V	1.7	2.5	mA
		$\bar{E}$ input	A at 0 V, $\bar{E}$ at 8.8 V, REF at 0 V, Y at 0 V	$\bar{E}$ at 8.8 V	2	3	
$I_{O(on)}$	On-state output current	$V_{CC} = 3.2 \text{ V}$ , $V_{SS} = 6.5 \text{ V}$ , A to 6.5 V thru 1 k $\Omega$ , REF at 2.15 V, Y to 2.15 V thru 50 $\Omega$		$\bar{E}$ to 8.8 V thru 100 k $\Omega$ ,	-8	-13	mA
$I_{O(off)}$	Off-state output current (from Y to $V_{DD}$ )	A to 8.8 V thru 100 k $\Omega$ , REF at 0 V, Y at 0 V		$\bar{E}$ at 0 V,	-100	-300	$\mu\text{A}$
		A at 8.8 V, REF at 0 V, Y at 0 V		$\bar{E}$ to 6.5 V thru 1 k $\Omega$ ,	-200	-1000	
$V_{O(on)}$	On-state output voltage	$V_{CC} = 3.2 \text{ V}$ , $V_{SS} = 6.5 \text{ V}$ , A to 6.5 V thru 1 k $\Omega$ , REF open,		$\bar{E}$ to 8.8 V thru 100 k $\Omega$ , $I_{O(on)} = -50 \text{ mA}$	2.5	2.9	V
$I_{CC}$	Current into $V_{CC}$ terminal	All A inputs at 0 V, REF at 0 V, Y at 0 V		$\bar{E}$ at 0 V,	10	500	$\mu\text{A}$
$I_{SS}$	Current into $V_{SS}$ terminal	All A inputs at 8.8 V, REF at 2.15 V, Y to 0 V thru 50 $\Omega$		$\bar{E}$ to 8.8 V thru 100 k $\Omega$ ,	2	8	mA
		$V_{CC} = 0 \text{ V}$ , REF at 0 V, Y at 0 V		All A inputs at 0 V, $\bar{E}$ at 0 V,	10	500	$\mu\text{A}$

SN75494 electrical characteristics,  $V_{CC} = 8.8 \text{ V}$ ,  $V_{SS} = 8.8 \text{ V}$ ,  $T_A = 0^\circ\text{C}$  to  $70^\circ\text{C}$  (unless otherwise noted)

PARAMETER		TEST CONDITIONS		MIN	TYP†	MAX	UNIT
$I_I$	Input current	A input	A at 8.8 V, $\bar{E}$ at 8.8 V		2	3	mA
		$\bar{E}$ input	$V_{CC} = 3.2 \text{ V}$ , A at 8.8 V, $V_{CC} = 3.2 \text{ V}$ , $\bar{E}$ at 8.8 V	$\bar{E}$ to 8.8 V thru 100 k $\Omega$ ,	1.8	2.5	
$I_{O(off)}$	Off-state output current (from Y to $V_{DD}$ )	A to 8.8 V thru 100 k $\Omega$ , Y at 10 V		$\bar{E}$ at 0 V,	1	200	$\mu\text{A}$
		A at 8.8 V, Y at 10 V		$\bar{E}$ to 6.5 V thru 1 k $\Omega$ ,	1	100	
$V_{O(on)}$	On-state output voltage	$V_{CC} = 3.2 \text{ V}$ , $V_{SS} = 6.5 \text{ V}$ , $\bar{E}$ to 6.5 V thru 1 k $\Omega$ ,		A to 6.5 V thru 1 k $\Omega$ , $I_{OL} = 250 \text{ mA}$	0.25	0.4	V
$I_{CC}$	Current into $V_{CC}$ terminal	One A input to 8.8 V thru 100 k $\Omega$ , All other A inputs at 0 V		$\bar{E}$ at 0 V,	10	500	$\mu\text{A}$
		One A input at 8.8 V, All other A inputs at 0 V		$\bar{E}$ to 6.5 V thru 1 k $\Omega$ ,	60	500	
		One A input at 8.8 V, All other A inputs at 0 V		$\bar{E}$ at 0 V,	11	20	mA
$I_{SS}$	Current into $V_{SS}$ terminal	$V_{CC} = 3.2 \text{ V}$ , $\bar{E}$ at 0 V,		All A inputs at 0 V	10	500	$\mu\text{A}$

† All typical values are at  $T_A = 25^\circ\text{C}$ .

9

# TYPES SN75493, SN75494

## MOS-TO-LED SEGMENT AND DIGIT DRIVERS

### TYPICAL APPLICATION DATA

Figure 1 is an example of time multiplexing the individual digits in a visible display to minimize display circuitry. Up to twelve digits, each of which use a seven-segment display with decimal point, may be displayed using only two SN75493 and two SN75494 drivers.

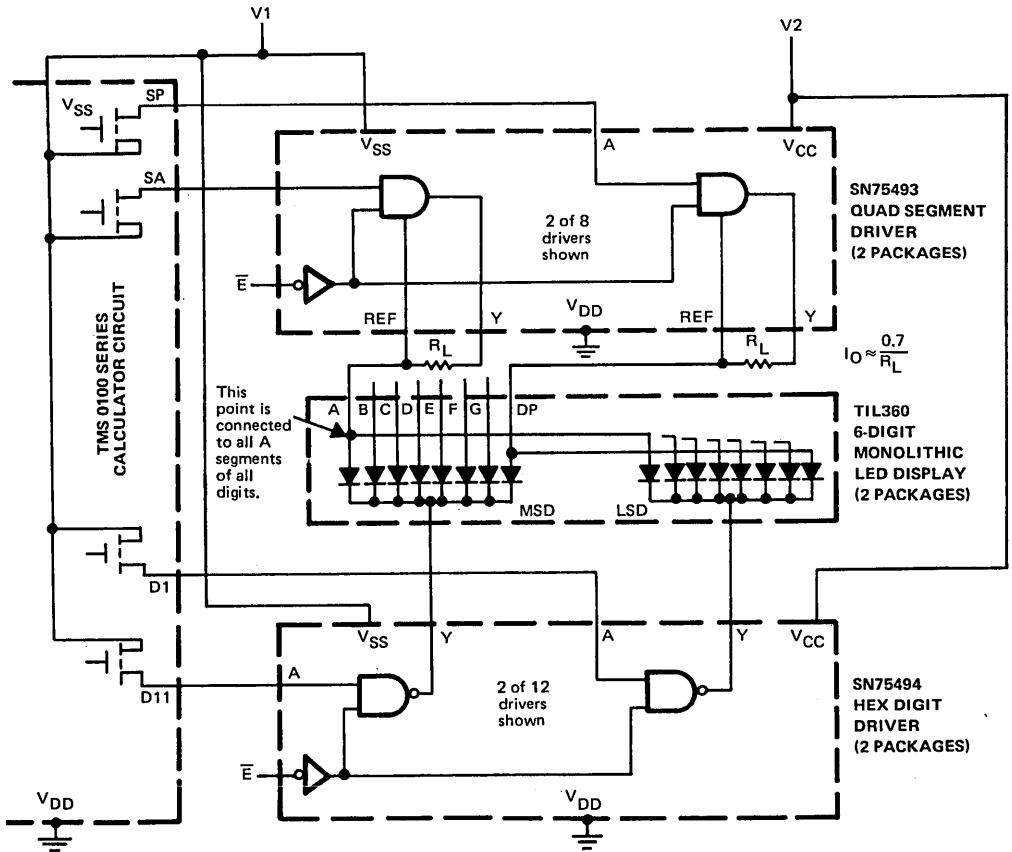

FIGURE 1—INTERFACING BETWEEN MOS CALCULATOR CIRCUIT AND LED MULTIDIGIT DISPLAY

NOTE: Operating ranges of V1 and V2 are 6.5 V to 8.8 V and 3.2 V to 8.8 V, respectively.



# INTERFACE CIRCUITS

# TYPES SN75496, SN75496A HEX TTL-TO-LED DIGIT DRIVERS

BULLETIN NO. DL-S 12585, FEBRUARY 1978

## HEX DIGIT DRIVER FOR INTERFACING BETWEEN TTL AND LIGHT-EMITTING-DIODE (LED) DISPLAYS

- 250-mA Sink Capability
- Rated for 10-V Operation ('496)
- Rated for 20-V Operation ('496A)
- TTL Input Compatibility
- Low Standby Power
- High-Gain Darlington Circuits

### description

The SN75496 and SN75496A are monolithic integrated circuits designed to be used with TTL integrated circuits and common-cathode LED's in serially addressed multi-digit displays. In a time-multiplexed system, which uses a segment-address-and-digit-scan method of LED drive, the number of drivers required can be minimized.

The SN75496 is characterized for operation to 10 volts, and the SN75496A is characterized for operation to 20 volts.

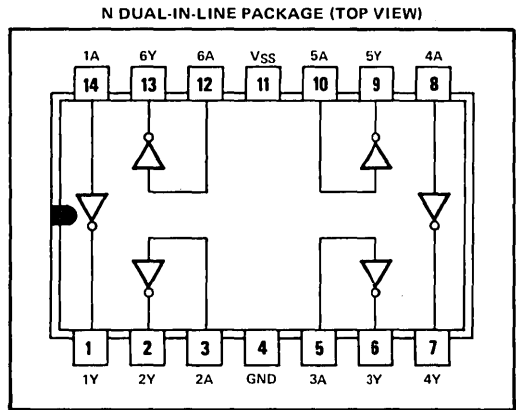

### schematic (each driver)

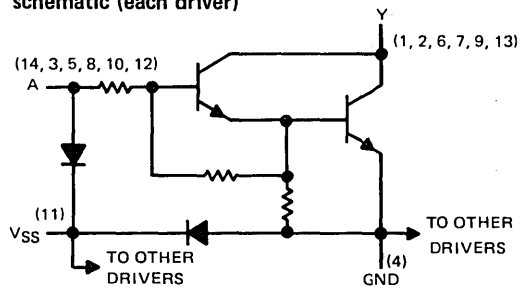

### absolute maximum ratings over operating free-air temperature range (unless otherwise noted)

	SN75496	SN75496A	UNIT
Input voltage range (see Note 1)	-5 to V <sub>SS</sub>	-5 to V <sub>SS</sub>	V
Output voltage (see Note 2)	10	20	V
Output-to-input voltage	10	20	V
Voltage at V <sub>SS</sub> terminal with respect to any other device terminal	10	20	V
Output current	each output	250	mA
	all outputs	600	
Continuous total dissipation at (or below) 25°C free-air temperature (see Note 3)	800	800	mW
Operating free-air temperature range	0 to 70	0 to 70	°C
Storage temperature range	-65 to 150	-65 to 150	°C
Lead temperature 1/16 inch from case for 10 seconds	260	260	°C

- NOTES: 1. The input is the only device terminal that may be negative with respect to ground.  
 2. Voltage values are with respect to network ground terminal unless otherwise noted.  
 3. For operation above 25°C free-air temperature, derate linearly at the rate of 9.2 mW/°C from 63°C to 736 mW at 70°C.

### TENTATIVE DATA SHEET

This document provides tentative information on a new product. Texas Instruments reserves the right to change specifications for this product in any manner without notice.

**TEXAS INSTRUMENTS**  
INCORPORATED

POST OFFICE BOX 225012 • DALLAS, TEXAS 75265

# TYPES SN75496, SN75496A

## HEX TTL-TO-LED DIGIT DRIVERS

electrical characteristics,  $V_{SS} = 10\text{ V}$  for SN75496,  $V_{SS} = 20\text{ V}$  for SN75496A,  
 $T_A = 0^\circ\text{C}$  to  $70^\circ\text{C}$  (unless otherwise noted)

PARAMETER	TEST CONDITIONS	MIN	TYP†	MAX	UNIT	
$V_{IH}$	High-level input voltage	2.4			V	
$V_{IL}$	Low-level input voltage			0.8	V	
$V_{OL}$	Low-level output voltage	$V_I = 2.4\text{ V}$ , $I_{OL} = 250\text{ mA}$ , $T_A = 25^\circ\text{C}$	0.9	1.2	V	
		$V_I = 2.4\text{ V}$ , $I_{OL} = 250\text{ mA}$		1.5		
$I_{OH}$	High-level output current	$V_{OH} = V_{SS}$ , $V_I = 0.8\text{ V}$		200	$\mu\text{A}$	
$I_I$	Input current at maximum input voltage	$V_I = V_{SS}$ , $I_{OL} = 20\text{ mA}$	SN75496	2.2	3.3	mA
			SN75496A	4.7	7.2	
$I_{IH}$	High-level input current	$V_I = 2.4\text{ V}$ , $V_O = V_{SS}$		400	$\mu\text{A}$	
$I_{IL}$	Low-level input current	$V_I = 0.8\text{ V}$		100	$\mu\text{A}$	
$I_{SS}$	Current into $V_{SS}$ terminal	$V_I = -5\text{ V}$ to $V_{SS}$		1	mA	

† All typical values are at  $25^\circ\text{C}$ .

switching characteristics,  $V_{CC} = 5\text{ V}$ ,  $T_A = 25^\circ\text{C}$

PARAMETER	TEST CONDITIONS	MIN	TYP	MAX	UNIT
$t_{PLH}$	Propagation delay time, low-to-high-level output	$R_L = 39\ \Omega$ , $C_L = 15\ \text{pF}$ ,	300		ns
$t_{PHL}$	Propagation delay time, high-to-low-level output	See Figure 1	30		ns

### PARAMETER MEASUREMENT INFORMATION

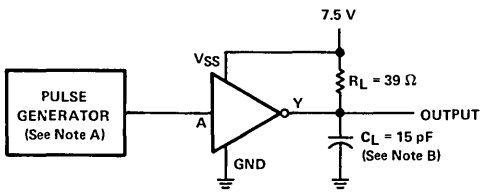

TEST CIRCUIT

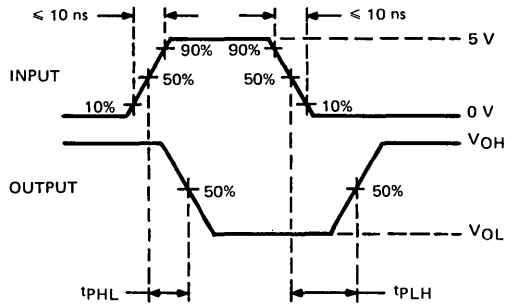

VOLTAGE WAVEFORMS

NOTES: A. The pulse generator has the following characteristics:  $Z_{out} = 50\ \Omega$ ,  $PRR = 100\ \text{kHz}$ ,  $t_w = 1\ \mu\text{s}$ .  
 B.  $C_L$  includes probe and jig capacitance.

FIGURE 1—PROPAGATION DELAY TIMES

# INTERFACE CIRCUITS

# TYPES SN75497, SN75498 MOS-TO-LED 7- OR 9-CHANNEL DRIVERS

BULLETIN NO. DL-S 7712490, MAY 1977

- 100-mA Output Sink Current Capability
- Low-Voltage Operation
- MOS- and TTL-Compatible Inputs
- Input Threshold . . . 2.7 V Max
- 7 Drivers (SN75497) or 9 Drivers (SN75498) per Package
- Low-Voltage Saturating Outputs
- Low Standby Power

## description

The SN75497 and SN75498 are designed to drive common-cathode LED's in serially addressed multi-digit displays used in conjunction with MOS calculator circuits. The input of each circuit is capable of interfacing with an MOS push-pull output buffer while the output is capable of sinking the output current from a strobed LED display. These drivers are also essentially compatible with TTL inputs. They have a guaranteed threshold of 2.7 volts maximum, making them ideal for two-battery calculators or other low-voltage battery systems. They are designed to be used with active-pull-down MOS devices, but can also be used with open-drain MOS outputs with the addition of pull-down resistors on each input.

The 100-mA output current capability (open collector) and low output saturation voltage makes these devices ideal for other applications such as lamp drivers, relay drivers, line drivers, high-fan-out TTL buffers, etc. The advantages over earlier digit drivers include lower operating voltage, lower output saturation voltage, lower input current, and higher input voltage range.

## schematic (each driver)

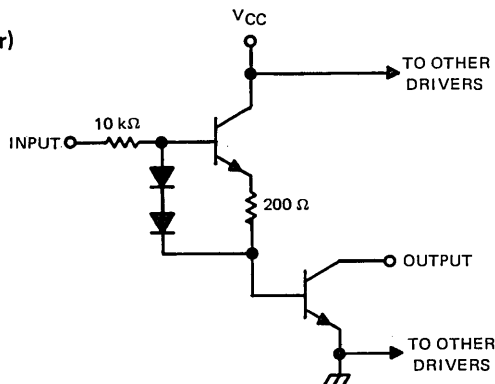

SN75497 . . . N DUAL-IN-LINE PACKAGE  
(TOP VIEW)

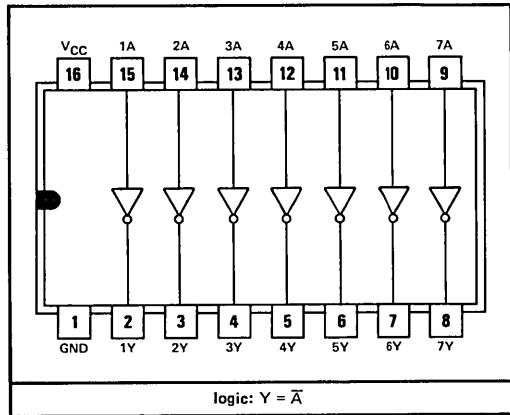

SN75498 . . . N DUAL-IN-LINE PACKAGE  
(TOP VIEW)

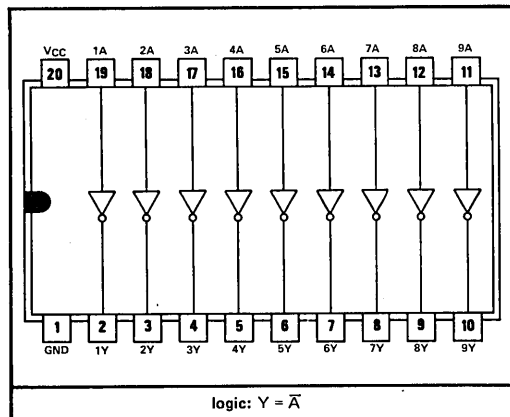

9

TEXAS INSTRUMENTS  
INCORPORATED

POST OFFICE BOX 225012 • DALLAS, TEXAS 75265

# TYPES SN75497, SN75498

## MOS-TO-LED 7- OR 9-CHANNEL DRIVERS

### absolute maximum ratings over operating free-air temperature range (unless otherwise noted)

Supply voltage, $V_{CC}$ (see Note 1)	7 V
Input voltage	-11 V to $V_{CC}$
Output voltage	$V_{CC}$
Continuous output collector current	125 mA
Ground-terminal current	250 mA
Continuous total dissipation	500 mW
Operating free-air temperature range	0°C to 70°C
Storage temperature range	-65°C to 150°C
Lead temperature 1/16 inch from case for 10 seconds	260°C

NOTE 1: Voltage values are with respect to network ground terminal.

### recommended operating conditions

	MIN	MAX	UNIT
Supply voltage, $V_{CC}$	2.7	6.6	V
High-level input voltage, $V_{IH}$	2.7	$V_{CC}$	V
Low-level input voltage, $V_{IL}$	-8.5	0	V
Output Current, $I_O$		100	mA
Operating free-air temperature, $T_A$	0	70	°C

### electrical characteristics over recommended free-air temperature range (unless otherwise noted)

PARAMETER		TEST CONDITIONS		MIN	TYP†	MAX	UNIT
$I_{O(off)}$	Off-state output current	$V_{CC} = 6.6$ V,	A at 0 V,		10	100	$\mu$ A
$V_{O(on)}$	On-state output voltage	$V_{CC} = 6.6$ V,	A at 6.6 V thru 500 $\Omega$ ,		0.24	0.4	V
		$V_{CC} = 2.7$ V,	A at 2.7 V thru 500 $\Omega$	$I_O = 50$ mA	0.12	0.25	
$I_{IH}$	High-level input current	$V_{CC} = 6.6$ V,	A at 6.6 V,		0.6	1	mA
		$V_{CC} = 2.7$ V,	A at 2.7 V,	$I_O = 100$ mA		0.4	
$I_{IL}$	Low-level input current	$V_{CC} = 6.6$ V,	A at -8.5 V,		-10	-100	$\mu$ A
		$V_{CC} = 2.7$ V,	A at -8.5 V,	$V_O = 6.6$ V		-100	
$I_{CC}$	Supply current	$V_{CC} = 6.6$ V,	One driver on		2.5	5	mA
			$I_O = 100$ mA,	Other A inputs at 0 V			
	All drivers off	$V_{CC} = 6.6$ V,	All inputs at 0 V			200	$\mu$ A

† All typical values are at  $T_A = 25^\circ$  C

# TYPES SN75497, SN75498 MOS-TO-LED 7- OR 9-CHANNEL DRIVERS

switching characteristics,  $V_{CC} = 5\text{ V}$ ,  $T_A = 25^\circ\text{C}$

PARAMETER	TEST CONDITIONS	MIN	TYP	MAX	UNIT
$t_{PLH}$ Propagation delay time, low-to-high level output	$C_L = 15\text{ pF}$ , $R_L = 47\ \Omega$		250		ns
$t_{PHL}$ Propagation delay time, high-to-low level output			40		ns

## PARAMETER MEASUREMENT INFORMATION

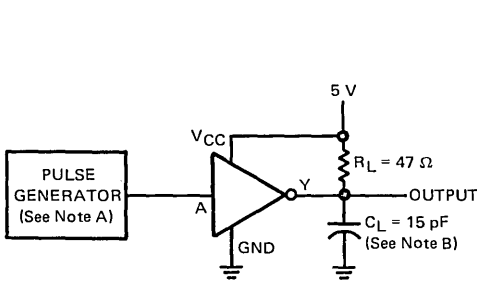

TEST CIRCUITS

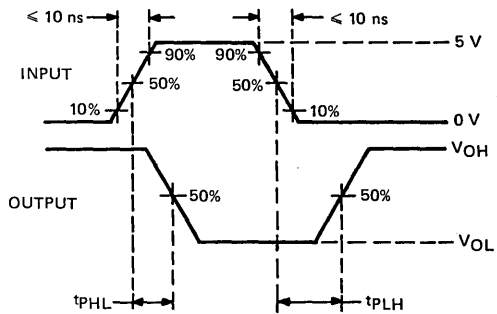

VOLTAGE WAVEFORMS

- NOTES: A. The pulse generator has the following characteristics:  $Z_{out} = 50\ \Omega$ ,  $PRR = 100\text{ kHz}$ ,  $t_w = 1\ \mu\text{s}$ .  
B.  $C_L$  includes probe and jig capacitance.

FIGURE 1—PROPAGATION DELAY TIMES

## TYPICAL CHARACTERISTICS

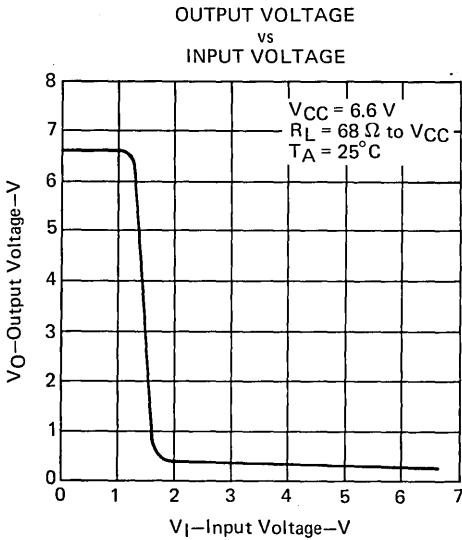

FIGURE 2

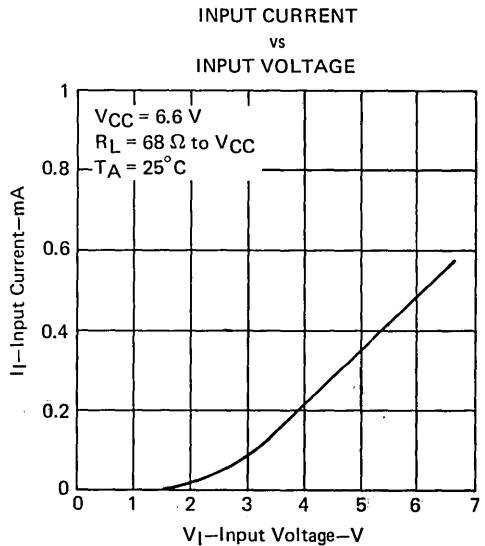

FIGURE 3

**TEXAS INSTRUMENTS**  
INCORPORATED

POST OFFICE BOX 225012 • DALLAS, TEXAS 75265



# INTERFACE CIRCUITS

# TYPES SN75500A, SN75502A AC PLASMA DISPLAY X-AXIS DRIVERS

BULLETIN NO. DL-S 12622, APRIL 1980

- Each Device Drives 32 Axis Lines
- High-Speed Serially Shifted Data Input Operation (4 MHz max)
- 100-V Output Voltage Swing Capability
- 20-mA Output Current Operation
- Low-Power Nonswitching Operation
- Fast Output Transitions
- Totem Pole Outputs
- Sink and Source Clamp Diodes
- SN75500A Has CMOS-Compatible Inputs
- SN75502A Has TTL-Compatible Inputs
- Selects 1 of 8 Lines Within 1 of 4 Groups
- Shift Register Can Retain Data on All Outputs Indefinitely While Clock is High

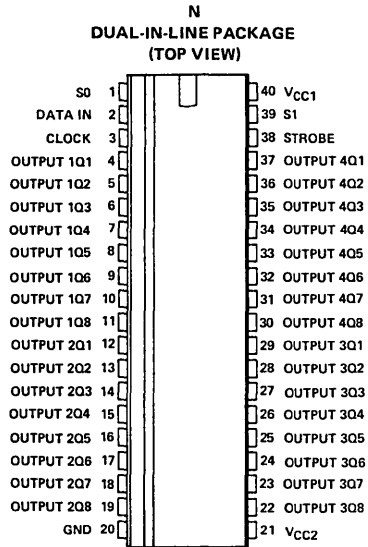

## description

The SN75500A and SN75502A are monolithic BIFET integrated circuits (bipolar, double-diffused MOS, n-channel MOS, and p-channel MOS transistors on the same chip<sup>†</sup>) designed to perform the select operation along the X-axis of a plasma display. The SN75500A is designed with CMOS-compatible inputs while the SN75502A is designed to be driven by TTL circuitry.

These devices each have an 8-bit shift register and a 2-to-4-line decoder, which steers the 8-bit data string to one of four groups of eight outputs. The shift register has indefinite latch capability when the clock input is held high. The decoder is controlled by inputs S0 and S1. The outputs are activated by the strobe input. When the strobe input is driven low, the selected 8-bit output group reflects the inverted data input string while the other twenty-four outputs remain low. With a capacitive load, this requires minimal power for driving the output.

The device inputs are diode-clamped p-n-p inputs and will assume a high logic level when open circuited. The nominal input threshold is 5 volts for the SN75500A and 1.5 volts for the SN75502A. The device outputs are totem-pole structures formed by double-diffused MOS (DMOS) transistors with clamp diodes to both ground and VCC2.

## functional block diagram

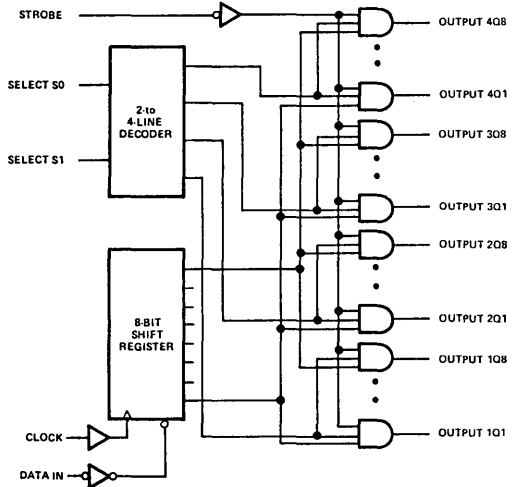

<sup>†</sup>Patent pending

# TYPES SN75500A, SN75502A

## AC PLASMA DISPLAY X-AXIS DRIVERS

FUNCTION TABLE

FUNCTION	INPUTS				OUTPUTS									
	DATA	CLOCK	S1	S0	STROBE	SHIFT REGISTERS				1Q1...1Q8	2Q1...2Q8	3Q1...3Q8	4Q1...4Q8	
						R1	R2	R3...R8						
LOAD	H	↑	X	X	H	L	R <sub>1n</sub>	R <sub>2n</sub>	R <sub>3n</sub> ...R <sub>8n</sub>		L...L	L...L	L...L	L...L
	L	↑	X	X	H	H	R <sub>1n</sub>	R <sub>2n</sub>	R <sub>3n</sub> ...R <sub>8n</sub>		L...L	L...L	L...L	L...L
STROBE	X	X	X	X	H	R <sub>1n</sub>	R <sub>2n</sub>	R <sub>3n</sub> ...R <sub>8n</sub>		L...L	L...L	L...L	L...L	
	X	H	L	L	L	R <sub>1n</sub>	R <sub>2n</sub>	R <sub>3n</sub> ...R <sub>8n</sub>		R <sub>1</sub> ...R <sub>8</sub>	L...L	L...L	L...L	
	X	H	L	H	L	R <sub>1n</sub>	R <sub>2n</sub>	R <sub>3n</sub> ...R <sub>8n</sub>		L...L	R <sub>1</sub> ...R <sub>8</sub>	L...L	L...L	
	X	H	H	L	L	R <sub>1n</sub>	R <sub>2n</sub>	R <sub>3n</sub> ...R <sub>8n</sub>		L...L	L...L	R <sub>1</sub> ...R <sub>8</sub>	L...L	
	X	H	H	H	L	R <sub>1n</sub>	R <sub>2n</sub>	R <sub>3n</sub> ...R <sub>8n</sub>		L...L	L...L	L...L	R <sub>1</sub> ...R <sub>8</sub>	

H = high level, L = low level, X = irrelevant, ↑ = low-to-high-level transition

R<sub>1</sub>...R<sub>8</sub> = levels currently at internal outputs of shift registers one through eight, respectively.

R<sub>1n</sub>...R<sub>8n</sub> = levels at internal outputs of shift registers one through eight, respectively, before the most recent low-level pulse at the clock input.

### typical operating sequence

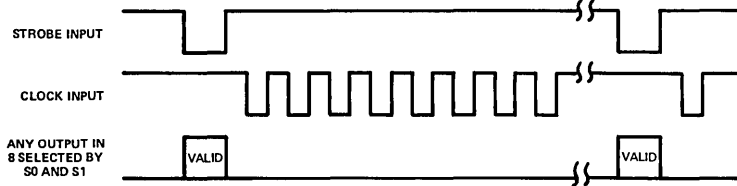

### absolute maximum ratings over operating free-air temperature range (unless otherwise noted)

Supply voltage, V <sub>CC1</sub> (see Note 1)	15 V
Supply voltage, V <sub>CC2</sub>	100 V
Input voltage	V <sub>CC1</sub>
Continuous total dissipation at (or below) 25°C free-air temperature (see Note 2)	1650 mW
Operating free-air temperature range	0°C to 70°C
Storage temperature range	-65°C to 150°C
Lead temperature 1/16 inch (1,6 mm) from case for 10 seconds	260°C

NOTES: 1. Voltage values are with respect to network ground terminal.

2. For operation above 25°C free-air temperature, derate linearly to 1056 mW at 70°C at the rate of 13.2 mW/°C.



# TYPES SN75500A, SN75502A AC PLASMA DISPLAY X-AXIS DRIVERS

## recommended operating conditions

	MIN	NOM	MAX	UNIT
Supply voltage, $V_{CC1}$	10.8	12	13.2	V
Supply voltage, $V_{CC2}$	$V_{CC1}$		100	V
Peak high-level output current			-20	mA
Peak low-level output current			20	mA
High-level output clamp current			20	mA
Low-level output clamp current			-20	mA
Input data rate	0		4	MHz
Width of high clock pulse, $t_{wH}$	125			ns
Width of low clock pulse, $t_{wL}$	125		600	ns
Data setup time before low-to-high transition of clock, $t_{su}$	125			ns
Data hold time after low-to-high transition of clock, $t_h$	0			ns
Operating free-air temperature, $T_A$	0		70	°C

## electrical characteristics over recommended operating free-air temperature range (unless otherwise noted)

PARAMETER	TEST CONDITIONS	SN75500A		SN75502A		UNIT			
		MIN	TYP†	MAX	MIN		TYP†	MAX	
$V_{IH}$ High-level input voltage		7			2		V		
$V_{IL}$ Low-level input voltage				3		0.8	V		
$V_{IK}$ Input clamp voltage	$V_{CC1} = 12\text{ V}, I_I = -12\text{ mA}$		-1	-1.5		-1	-1.5	V	
$V_{OH}$ High-level output voltage	$V_{CC1} = 13.2\text{ V}, V_{CC2} = 100\text{ V}$	$I_{OH} = -1\text{ mA}$	95	97.5		95	97.5		
		$I_{OH} = -10\text{ mA}$	92	94.5		92	94.5		
		$I_{OH} = -15\text{ mA}$	91	93.5		91	93.5		
$V_{OL}$ Low-level output voltage	$V_{CC1} = 13.2\text{ V}, V_{CC2} = 100\text{ V}$	$I_{OL} = 1\text{ mA}$		0.85	2	0.85	2		
		$I_{OL} = 10\text{ mA}$		2	4		2	4	
		$I_{OL} = 15\text{ mA}$		2.75	5		2.75	5	
$V_{OK}$ Output clamp voltage	$V_{CC2} = 100\text{ V}$	$I_O = 20\text{ mA}$		101	102.5		101	102.5	
		$I_O = -20\text{ mA}$		-1.2	-2.5		-1.2	-2.5	
$I_{IH}$ High-level input current	$V_{CC1} = 13.2\text{ V}, V_I = V_{IH}\text{ min}$		-0.1	40		0.1	40	μA	
$I_{IL}$ Low-level input current	$V_{CC1} = 13.2\text{ V}, V_I = V_{IL}\text{ max}$		-20	-150		-20	-150	μA	
$I_{CC1}$ Supply current	$V_{CC1} = 13.2\text{ V}$	$V_I = V_{IH}\text{ min}$		1	2		1	2	mA
		$V_I = V_{IL}\text{ max}$		8	12		8	12	
$I_{CC2}$ Supply current	$V_{CC2} = 100\text{ V}$	Eight outputs high		1	3		1	3	mA
		All outputs low		1	2		1	2	

† Typical values are at  $V_{CC1} = 12\text{ V}, T_A = 25^\circ\text{C}$ .

## switching characteristics, $V_{CC1} = 12\text{ V}, V_{CC2} = 65\text{ V}, T_A = 25^\circ\text{C}$

PARAMETER	TEST CONDITIONS	MIN	MAX	UNIT
$t_{DHL}$ Delay time, high-to-low-level output from strobe input	$C_L = 30\text{ pF},$ See Figure 2		250	ns
$t_{DLH}$ Delay time, low-to-high-level output from strobe input			450	ns
$t_{THL}$ Transition time, high-to-low-level output			200	ns
$t_{TLH}$ Transition time, low-to-high-level output			300	ns

# TYPES SN75500A, SN75502A AC PLASMA DISPLAY X-AXIS DRIVERS

## PARAMETER MEASUREMENT INFORMATION

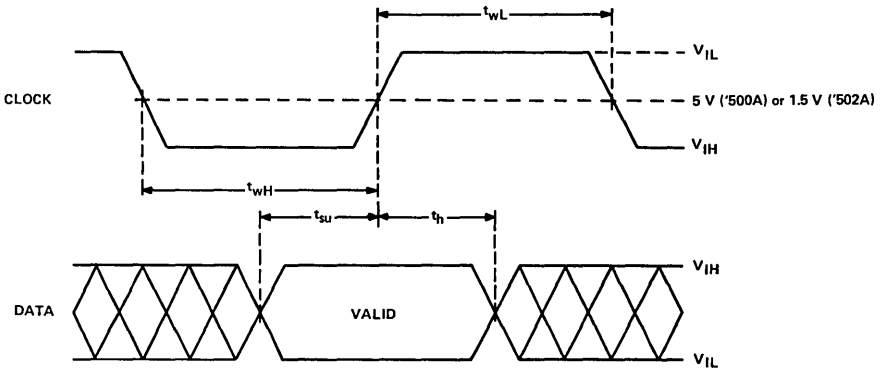

FIGURE 1—DATA INPUT TIMING

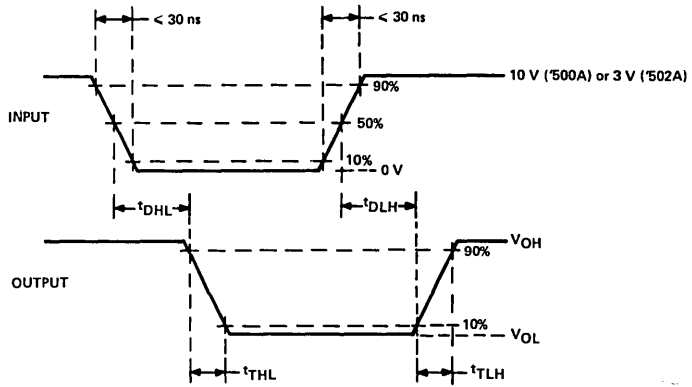
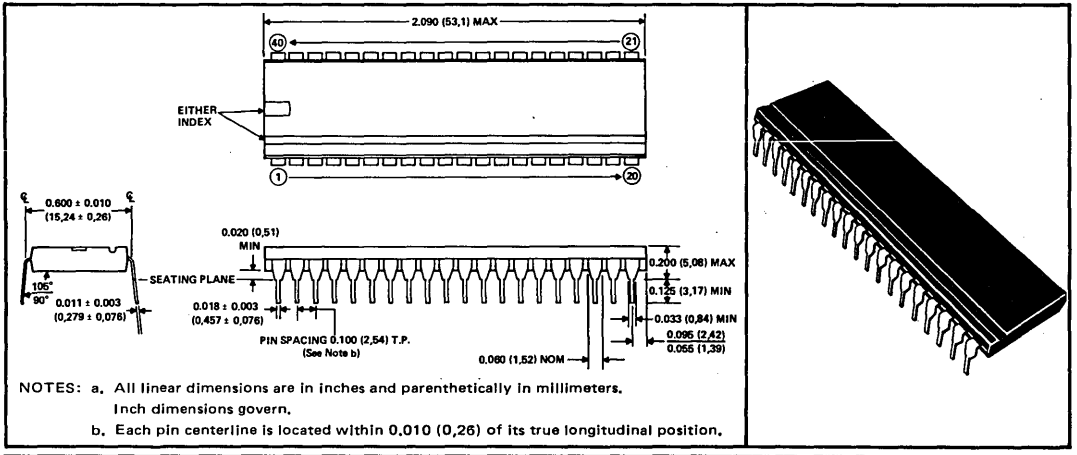

FIGURE 2—OUTPUT SWITCHING TIMES

## MECHANICAL DATA

### 40-pin N plastic dual-in-line package



# INTERFACE CIRCUITS

# TYPES SN75501A, SN75503A AC PLASMA DISPLAY Y-AXIS DRIVERS

BULLETIN NO. DL-S 12621, APRIL 1980

- Each Device Drives 32 Axis Lines
- High-Speed Serially Shifted Data Input Operation (4 MHz Max)
- 100-V Output Voltage Swing Capability
- 20-mA Output Current Operation
- Low-Power Nonswitching Operation
- Fast Output Transitions
- Totem-Pole Outputs
- Sink and Source Clamp Diodes
- SN75501A Has CMOS-Compatible Inputs
- SN75503A Has TTL-Compatible Inputs
- Performs Y-Axis Sustaining Function
- Static Shift Register Can Retain Data on all Outputs Indefinitely

DUAL-IN-LINE PACKAGE  
(TOP VIEW)

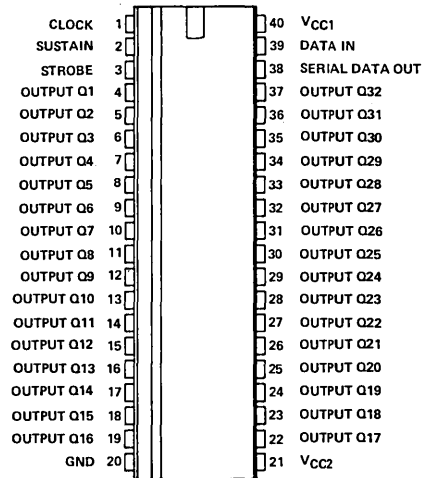

## description

The SN75501A and SN75503A are monolithic BIFET integrated circuits (bipolar, double-diffused MOS, n-channel MOS, and p-channel MOS transistors on the same chip<sup>†</sup>) designed to perform the select operation and the sustain function along the Y-axis of a plasma display. The SN75501A is designed with CMOS-compatible inputs while the SN75503A is designed to be driven by TTL circuitry.

These devices each have a 32-bit shift register with indefinite latch capability when the clock input is either high or low. Information at the data input meeting the setup time requirements is transferred into the shift register on the positive-going edge of the clock signal. Each shift register output drives its respective Q output through two gates controlled by the strobe and sustain inputs, respectively. The strobe input controls the outputs for writing and erase functions, while the sustain input controls the output for system sustaining along the Y-axis. The serial-data output can be used to cascade shift registers.

The device inputs are diode-clamped p-n-p inputs and will assume a high logic level when open-circuited. The nominal input threshold is 5 volts for the SN75501A and 1.5 volts for the SN75503A. The device outputs are totem-pole structures formed by double-diffused MOS (DMOS) transistors with clamp diodes to both ground and V<sub>CC2</sub>.

## functional block diagram

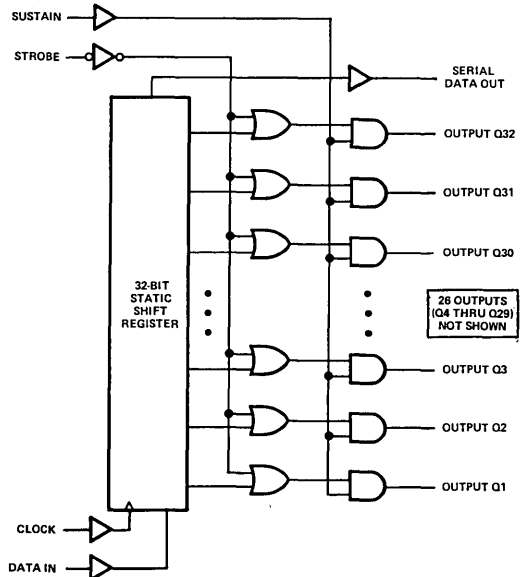

<sup>†</sup>Patent pending

# TYPES SN75501A, SN75503A

## AC PLASMA DISPLAY Y-AXIS DRIVERS

FUNCTION TABLE

FUNCTION	INPUTS				OUTPUTS						
	DATA IN	CLOCK	STROBE	SUSTAIN	SHIFT REGISTERS				SERIAL DATA	Q1	Q2
					R1	R2	R3 ... R32				
LOAD	H	↑	H	H	H	R <sub>1n</sub>	R <sub>2n</sub> ... R <sub>31n</sub>	R <sub>32n</sub>	H	H	H ... H
	L	↑	H	H	L	R <sub>1n</sub>	R <sub>2n</sub> ... R <sub>31n</sub>	R <sub>32n</sub>	H	H	H ... H
STROBE	X	X	H	H	R <sub>1n</sub>	R <sub>2n</sub>	R <sub>3n</sub> ... R <sub>32n</sub>	R <sub>32n</sub>	H	H	H ... H
	X	H	L	H	R <sub>1n</sub>	R <sub>2n</sub>	R <sub>3n</sub> ... R <sub>32n</sub>	R <sub>32n</sub>	R1	R2	R3 ... R32
SUSTAIN	X	X	X↑	L	R <sub>1n</sub>	R <sub>2n</sub>	R <sub>3n</sub> ... R <sub>32n</sub>	R <sub>32n</sub>	L	L	L ... L

H = high level, L = low level, X = Irrelevant, ↑ = low-to-high level transition.

R1 ... R32 = levels currently at internal outputs of shift registers one through thirty-two, respectively.

R<sub>1n</sub> ... R<sub>32n</sub> = levels at internal outputs of shift registers one through thirty-two, respectively, before the most recent low-level pulse at the clock input.

† To minimize delay time for the next output signals, it is recommended that Strobe remain high while Sustain is low. Delay time from Strobe to the Q outputs is typically longer than from Sustain.

### typical operating sequence

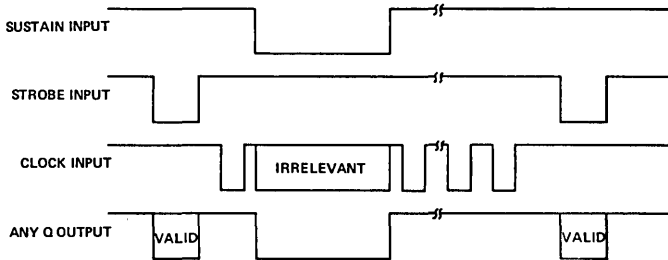

### absolute maximum ratings over operating free-air temperature range (unless otherwise noted)

Supply voltage, V <sub>CC1</sub> (see Note 1)	15 V
Supply voltage, V <sub>CC2</sub>	100 V
Input voltage	V <sub>CC1</sub>
Continuous total dissipation at (or below) 25°C free-air temperature (see Note 2)	1650 mW
Operating free-air temperature range	0°C to 70°C
Storage temperature range	-65°C to 150°C
Lead temperature 1/16 inch (1,6 mm) from case for 10 seconds	260°C

NOTES: 1. Voltage values are with respect to network ground terminal.

2. For operation above 25°C free-air temperature, derate linearly to 1056 mW at 70°C at the rate of 13.2 mW/°C.

# TYPES SN75501A, SN75503A AC PLASMA DISPLAY Y-AXIS DRIVERS

## recommended operating conditions

	MIN	NOM	MAX	UNIT
Supply voltage, V <sub>CC1</sub>	10.8	12	13.2	V
Supply voltage, V <sub>CC2</sub>	V <sub>CC1</sub>		100	V
Peak high-level output current			-20	mA
Peak low-level output current			20	mA
High-level output clamp current			20	mA
Low-level output clamp current			-20	mA
Input data rate	0		4	MHz
Width of high clock pulse, t <sub>WH</sub>	125			ns
Width of low clock pulse, t <sub>WL</sub>	125			ns
Data setup time before low-to-high transition of clock, t <sub>su</sub>	125			ns
Data hold time after low-to-high transition of clock, t <sub>h</sub>	0			ns
Operating free-air temperature, T <sub>A</sub>	0		70	°C

## electrical characteristics over recommended operating free-air temperature range (unless otherwise noted)

PARAMETER		TEST CONDITIONS		SN75501A			SN75503A			UNIT
				MIN	TYP†	MAX	MIN	TYP†	MAX	
V <sub>IH</sub>	High-level input voltage			7			2			V
V <sub>IL</sub>	Low-level input voltage					3			0.8	V
V <sub>IK</sub>	Input clamp voltage	V <sub>CC1</sub> = 12 V,	I <sub>I</sub> = -12 mA		-1	-1.5		-1	-1.5	V
V <sub>OH</sub>	High-level output voltage	Outputs 1 through 32	V <sub>CC1</sub> = 13.2 V,	I <sub>OH</sub> = -1 mA	95	97.5	95	97.5		V
			V <sub>CC2</sub> = 100 V	I <sub>OH</sub> = -10 mA	92	94.5	92	94.5		
		Serial data	V <sub>CC1</sub> = 10.8 V,	I <sub>OH</sub> = -15 mA	91	93.5	91	93.5		
V <sub>OL</sub>	Low-level output voltage	Outputs 1 through 32	V <sub>CC1</sub> = 13.2 V,	I <sub>OL</sub> = 1 mA		0.85	2	0.85	2	V
			V <sub>CC2</sub> = 100 V	I <sub>OL</sub> = 10 mA		2	4		2	
		Serial data	V <sub>CC1</sub> = 10.8 V,	I <sub>OL</sub> = 15 mA		2.75	5		2.75	
V <sub>OL</sub>	Low-level output voltage	Serial data	V <sub>CC1</sub> = 10.8 V,	I <sub>OL</sub> = 100 μA		0.1	1		0.1	1
				I <sub>O</sub> = 20 mA		101	102.5		101	102.5
V <sub>OK</sub>	Output clamp voltage	V <sub>CC2</sub> = 100 V	I <sub>O</sub> = -20 mA		-1.2	-2.5		-1.2	-2.5	V
I <sub>IH</sub>	High-level input current	V <sub>CC1</sub> = 13.2 V,	V <sub>I</sub> = V <sub>IH</sub> min		0.1	40		0.1	40	μA
I <sub>IL</sub>	Low-level input current	V <sub>CC1</sub> = 13.2 V,	V <sub>I</sub> = V <sub>IL</sub> max		-20	-150		-20	-150	μA
I <sub>CC1</sub>	Supply current	V <sub>CC1</sub> = 13.2 V	V <sub>I</sub> = V <sub>IH</sub> min		0.5	2		0.5	2	mA
			V <sub>I</sub> = V <sub>IL</sub> max		6	12		6	12	
I <sub>CC2</sub>	Supply current	V <sub>CC2</sub> = 100 V	All outputs high		1	3		1	3	mA
			All outputs low		1	3		1	3	

† Typical values are at V<sub>CC1</sub> = 12 V, T<sub>A</sub> = 25°C.

## switching characteristics, V<sub>CC1</sub> = 12 V, V<sub>CC2</sub> = 65 V, T<sub>A</sub> = 25°C

PARAMETER	TEST CONDITIONS	MIN	MAX	UNIT
t <sub>DHL</sub>	C <sub>L</sub> = 30 pF, See Figure 2		250	ns
t <sub>DLH</sub>			450	ns
t <sub>DHL</sub>			250	ns
t <sub>DLH</sub>			450	ns
t <sub>THL</sub>			200	ns
t <sub>TLH</sub>			300	ns

TEXAS INSTRUMENTS  
INCORPORATED

POST OFFICE BOX 225012 • DALLAS, TEXAS 75265

# TYPES SN75501A, SN75503A AC PLASMA DISPLAY Y-AXIS DRIVERS

## PARAMETER MEASUREMENT INFORMATION

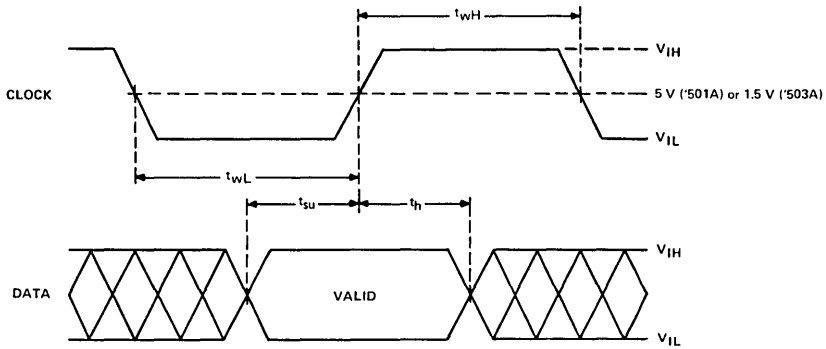

FIGURE 1—DATA INPUT TIMING

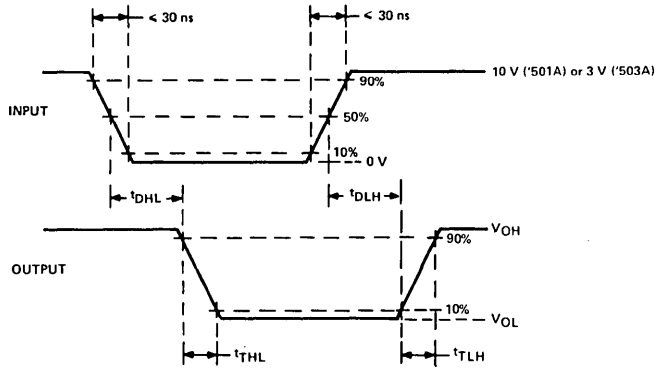
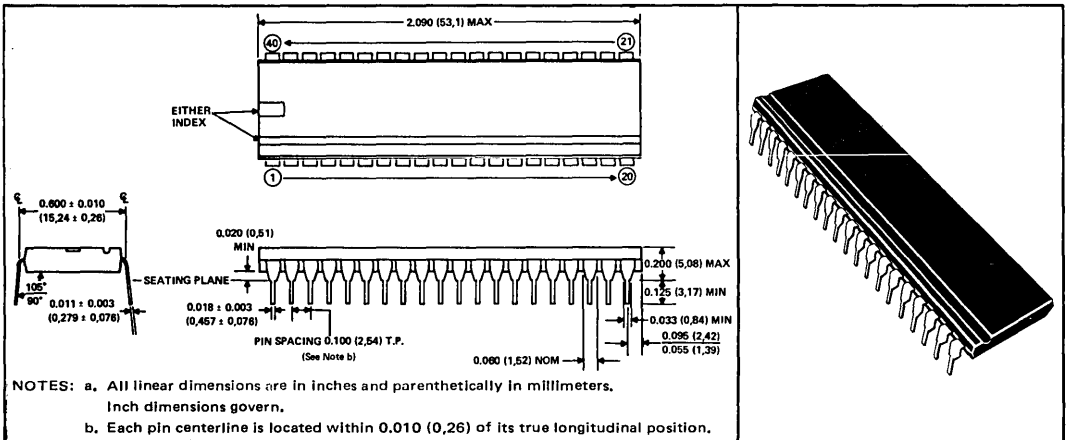

FIGURE 2—OUTPUT SWITCHING TIMES

## MECHANICAL DATA

40-pin N plastic dual-in-line package



TEXAS INSTRUMENTS  
INCORPORATED

POST OFFICE BOX 225012 • DALLAS, TEXAS 75265

# INTERFACE CIRCUITS

# TYPE SN75510 VACUUM FLUORESCENT DISPLAY DRIVER

BULLETIN NO. DL-S 12764, AUGUST 1980

- Each Device Drives 12 Lines
- 60-V Output Voltage Swing Capability
- 25-mA Output Source Current Capability
- High-Speed Serially-Shifted Data Input
- CMOS-Compatible Inputs
- Reset Input

## description

The SN75510 is a monolithic BIFET integrated circuit (bipolar, double-diffused, n-channel MOS, and P-channel MOS transistors on the same chip<sup>†</sup>), designed to drive a dot matrix or segmented vacuum fluorescent display.

All device inputs are diode-clamped p-n-p inputs and will assume a high logic level when open-circuited. The nominal input threshold is 5 volts. Outputs are totem-pole structures formed by an n-p-n emitter follower and diffused MOS (DMOS) transistors.

The device consists of a 12-bit shift register and 12 output AND gates. Data is entered into the shift register on the low-to-high transition of the clock. The active-low strobe input enables all Q outputs. The reset input sets the shift register contents to all lows. Serial data output from the shift register may be used to cascade shift registers. This output is not affected by the strobe input.

The SN75510 is characterized for operations from 0°C to 70°C.

N  
DUAL-IN-LINE PACKAGE  
(TOP VIEW)

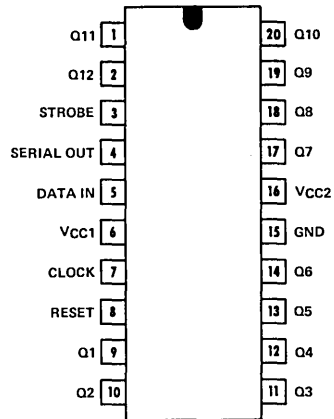

## logic symbol<sup>‡</sup>

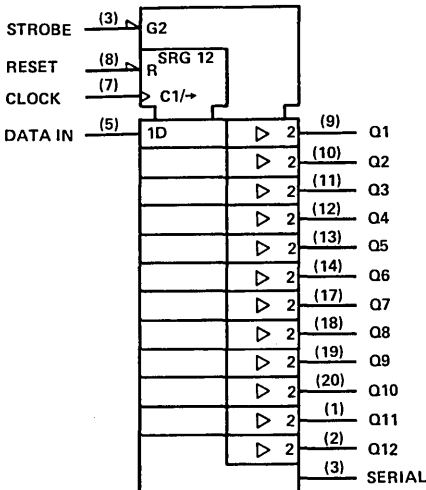

## functional block diagram

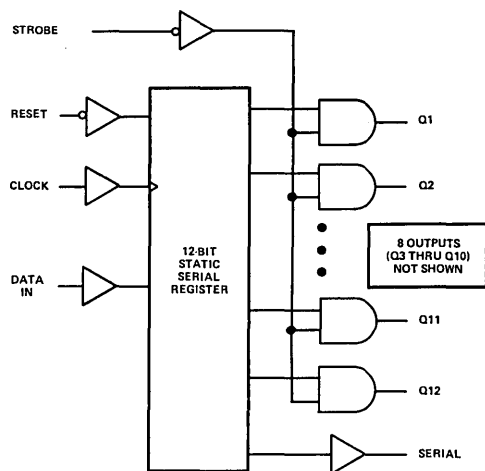

<sup>†</sup>Patent Pending.

<sup>‡</sup>This symbol is in accordance with IEEE Std 91/ANSI Y32.14 and current discussions in IEC and IEEE.

## PRODUCT PREVIEW

Copyright © 1980 by Texas Instruments Incorporated

This document contains information on a product under development. Texas Instruments reserves the right to change or discontinue this product without notice.

**TEXAS INSTRUMENTS**  
INCORPORATED

POST OFFICE BOX 225012 • DALLAS, TEXAS 75265

# TYPE SN75510

## VACUUM FLUORESCENT DISPLAY DRIVER

FUNCTION TABLE

FUNCTION	CONTROL INPUTS			SHIFT REGISTERS R1 THRU R12	OUTPUTS	
	RESET	CLOCK	STROBE		SERIAL	Q1 THRU Q12
LOAD	H	↑	X	Load and shift*	R12*	Determined by Strobe
STROBE	H	Not	H	No change	R12	All L
RESET	H	Not	L	No change	R12	R1 thru R12, respectively
RESET	L	X	X	All L	L	All L

H = high level, L = low level, X = Irrelevant, ↑ = low-to-high-level transition.

\*R12 and Serial output take on the state of R11, R11 takes on the state of R10, . . . R2 takes on the state of R1, and R1 takes on the state of the data input.

### typical operating sequence

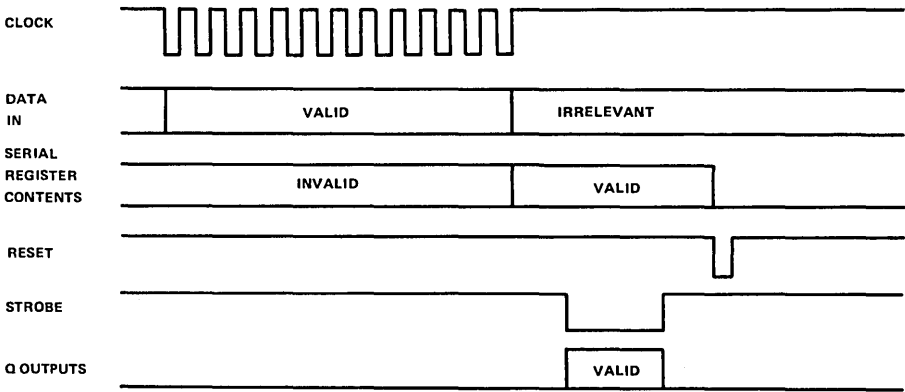

### schematics of inputs and outputs

9

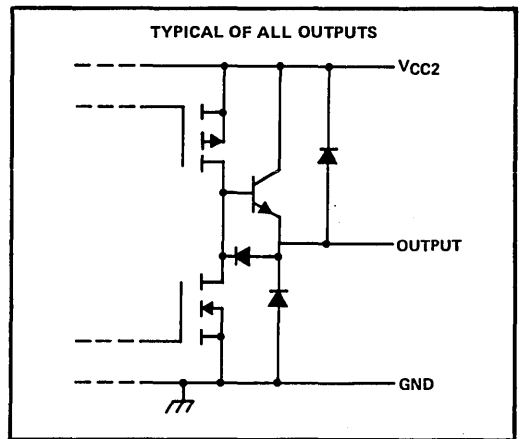
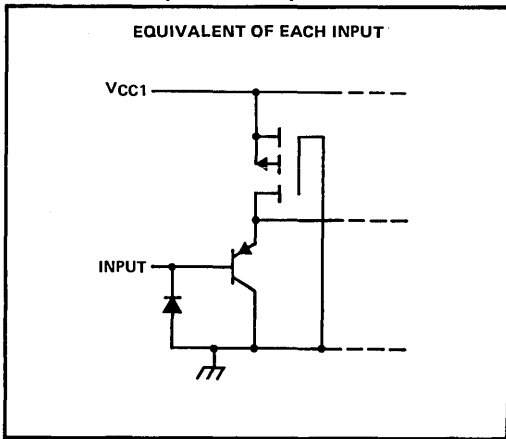



# TYPE SN75510 VACUUM FLUORESCENT DISPLAY DRIVER

## absolute maximum ratings over operating free-air temperature range (unless otherwise noted)

Supply voltage, $V_{CC1}$ (see Note 1)	15 V
Supply voltage, $V_{CC2}$	60 V
Input voltage	$V_{CC1}$
Continuous total dissipation at (or below) 70°C free-air temperature	650 mW
Operating free-air temperature range	0°C to 70°C
Storage temperature range	-65°C to 150°C
Lead temperature 1/16 inch (1,6 mm) from case for 10 seconds	260°C

NOTE 1: Voltage values are with respect to network ground terminals.

## recommended operating conditions

	MIN	NOM	MAX	UNIT
Supply voltage, $V_{CC1}$	10.8	12	13.2	V
Supply voltage, $V_{CC2}$			60	V
Peak high-level output current			-25	mA
Peak low-level output current			5	mA
Input data rate	0		4	MHz
Width of high clock pulse, $t_{WH}$ (see Figure 1)	125			ns
Width of low clock pulse, $t_{WL}$ (see Figure 1)	125			ns
Data setup time before low-to-high transition of clock, $t_{SU}$ (see Figure 1)	125			ns
Data hold time after low-to-high transition of clock, $t_H$ (see Figure 1)	0			ns
Operating free-air temperature, $T_A$	0		70	°C

## electrical characteristics over recommended operating free-air temperature range (unless otherwise noted)

PARAMETER		TEST CONDITIONS	MIN	TYP†	MAX	UNIT
$V_{IH}$	High-level input voltage		7			V
$V_{IL}$	Low-level input voltage				3	V
$V_{IK}$	Input clamp voltage	$V_{CC1} = 12\text{ V}, I_I = -12\text{ mA}$			-1.5	V
$V_{OH}$	High-level output voltage	Q outputs	$V_{CC1} = 10.8\text{ V}, V_{CC2} = 60\text{ V}, I_{OH} = -25\text{ mA}$	55	57.5	V
		Serial data	$V_{CC1} = 12\text{ V}, I_{OH} = -200\text{ }\mu\text{A}$	11	11.3	
$V_{OL}$	Low-level output voltage	Q outputs	$V_{CC1} = 12\text{ V}, I_{OL} = 5\text{ mA}$	1.9	5	V
		Serial data	$V_{CC1} = 12\text{ V}, I_{OL} = 200\text{ }\mu\text{A}$	0.2	0.5	
$I_{IH}$	High-level input current	$V_{CC1} = 13.2\text{ V}, V_I = 7\text{ V}$	0.01	10	$\mu\text{A}$	
$I_{IL}$	Low-level input current	$V_{CC1} = 13.2\text{ V}, V_I = 3\text{ V}$	-30	-150	$\mu\text{A}$	
$I_{CC1}$	Supply current	$V_{CC1} = 13.2\text{ V}$	$V_I = 7\text{ V}$	150	800	$\mu\text{A}$
			$V_I = 3\text{ V}$	10	12	mA
$I_{CC2}$	Supply current	$V_{CC1} = 13.2\text{ V}, V_{CC2} = 60\text{ V}$	All outputs high	5	8	mA
			Strobe at 7 V	100	500	$\mu\text{A}$

†Typical values are at  $V_{CC1} = 12\text{ V}, T_A = 25^\circ\text{C}$ .

## switching characteristics, $V_{CC1} = 12\text{ V}, V_{CC2} = 60\text{ V}, T_A = 25^\circ\text{C}$

PARAMETER		TEST CONDITIONS	MIN	MAX	UNIT
$t_{DHL}$	Delay time, high-to-low-level output from strobe input	$C_L = 30\text{ pF}$ See Figure 2		500	ns
$t_{DLH}$	Delay time, low-to-high-level output from strobe input			500	ns
$t_{THL}$	Transition time, high-to-low-level output			300	ns
$t_{TLH}$	Transition time, low-to-high-level output			300	ns

**TEXAS INSTRUMENTS**  
INCORPORATED

POST OFFICE BOX 225012 • DALLAS, TEXAS 75265

**TYPE SN75510  
VACUUM FLUORESCENT DISPLAY DRIVER**

**PARAMETER MEASUREMENT INFORMATION**

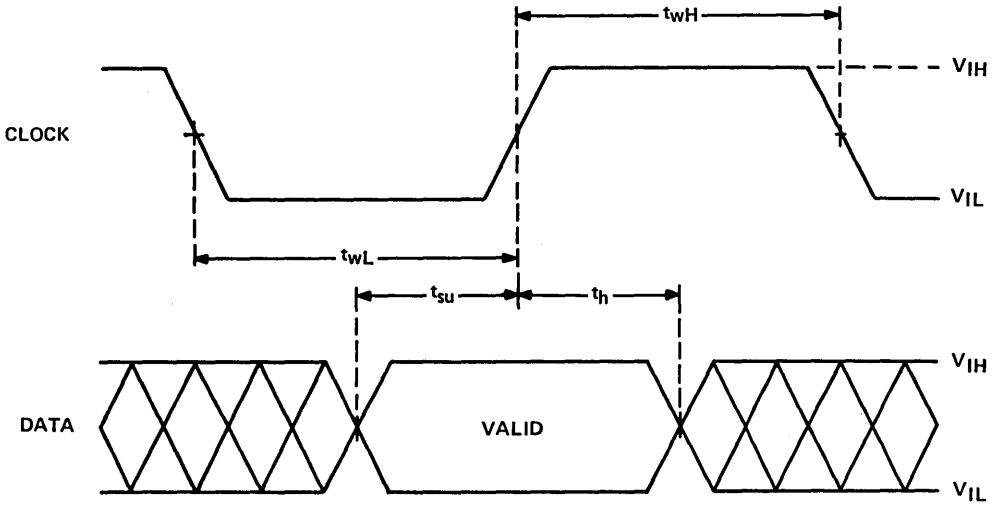

FIGURE 1 - INPUT TIMING

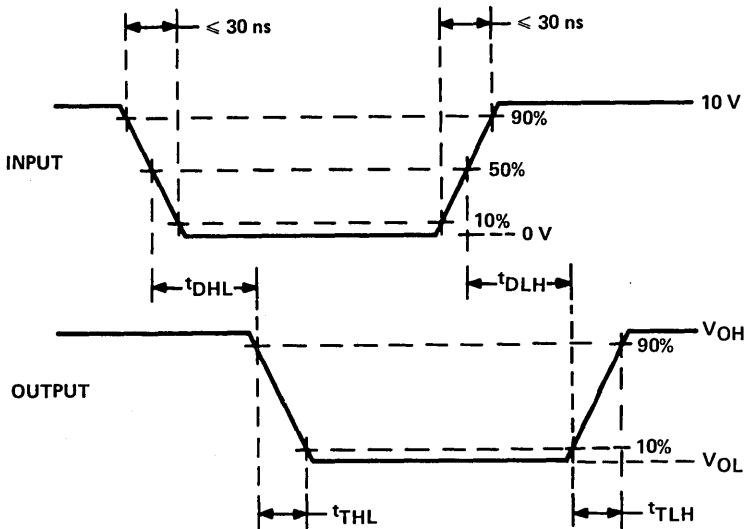

FIGURE 2 - SWITCHING TIMES

# INTERFACE CIRCUITS

# TYPE SN75511 VACUUM FLUORESCENT DISPLAY DRIVER

BULLETIN NO. DL-S 12765, AUGUST 1980

- Each Device Drives 12 Lines
- 60-V Output Voltage Swing Capability
- 25-mA Output Source Current Capability
- High-Speed Serially-Shifted Data Input
- CMOS-Compatible Inputs
- Latches on All Driver Outputs.

## description

The SN75511 is a monolithic BIFET integrated circuit (bipolar, double-diffused, n-channel MOS and p-channel MOS transistors on same chip<sup>†</sup>) designed to drive a dot matrix or segmented vacuum fluorescent display.

All device inputs are diode-clamped p-n-p inputs and will assume a high logic level when open-circuited. The nominal input threshold is 5 volts. Outputs are totem-pole structures formed by an n-p-n emitter follower and double-diffused MOS (DMOS) transistors.

The device consists of a 12-bit shift register, 12 latches, and 12 output AND gates. Serial data is entered into the shift register on the low-to-high transition of the clock. When high, the latch enable input transfers the shift register contents to the outputs of the 12 latches. The active-low strobe input enables all Q outputs. Serial data output from the shift register may be used to cascade shift registers. This output is not affected by the latch enable or strobe inputs.

The SN75511 is characterized for operation from 0°C to 70°C.

## logic symbol<sup>‡</sup>

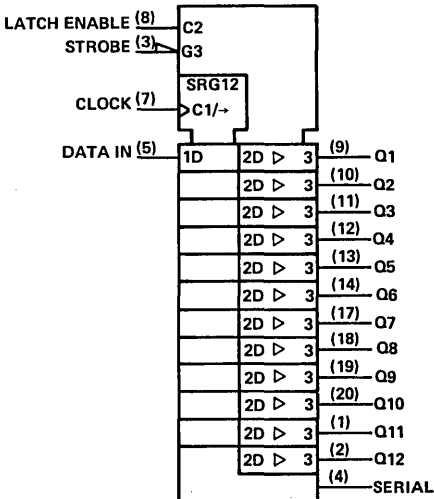

<sup>†</sup>Patent Pending

<sup>‡</sup>This symbol is in accordance with IEEE Std 91/ANSI Y32.14 and current discussions in IEC and IEEE.

N  
DUAL-IN-LINE PACKAGE  
(TOP VIEW)

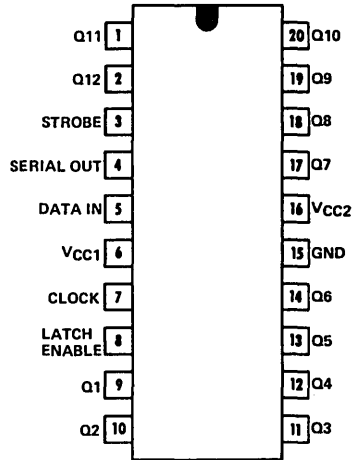

## functional block diagram

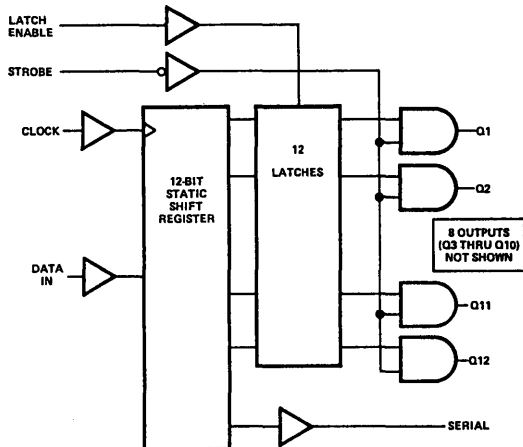

## PRODUCT PREVIEW

This document contains information on a product under development. Texas Instruments reserves the right to change or discontinue this product without notice.

**TEXAS INSTRUMENTS**  
INCORPORATED

POST OFFICE BOX 225012 • DALLAS, TEXAS 75265

Copyright © 1980 by Texas Instruments Incorporated

# TYPE SN7551

## VACUUM FLUORESCENT DISPLAY DRIVER

FUNCTION TABLE

FUNCTION	CONTROL INPUTS			SHIFT REGISTERS R1 THRU R12	LATCHES LC1 THRU LC12 <sup>†</sup>	OUTPUTS	
	CLOCK	LATCH ENABLE	STROBE			SERIAL	Q1 THRU Q12
LOAD	↑	X	X	Load and shift*	Determined by Latch Enable <sup>†</sup>	R12*	Determined by Strobe
	No↑	X	X	No change	Determined by Latch Enable <sup>†</sup>	R12	Determined by Strobe
LATCH	X	L	X	As determined above	Stored data	R12	Determined by Strobe
	X	H	X	As determined above	New data	R12	Determined by Strobe
STROBE	X	X	H	As determined above	Determined by Latch Enable <sup>†</sup>	R12	All L
	X	X	L	As determined above	Determined by Latch Enable <sup>†</sup>	R12	LC1 thru LC12, respectively

H = high level, L = Low level, X = Irrelevant, ↑ = low-to-high-level transition.

<sup>†</sup>New data enter the latches while Latch Enable is high. These data are stored while Latch Enable is low.

\* R12 takes on the state of R11, R11 takes on the state of R10, . . . R2 takes on the state of R1, and R1 takes on the state of the data input.

### typical operating sequence

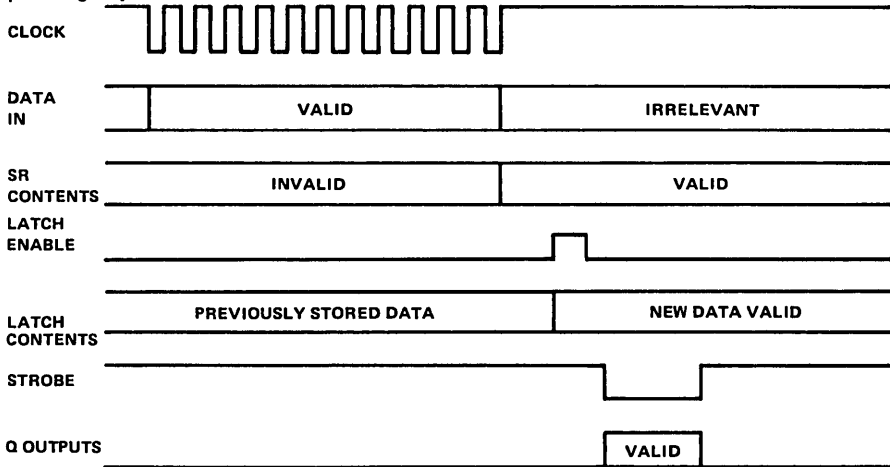

### schematics of inputs and outputs

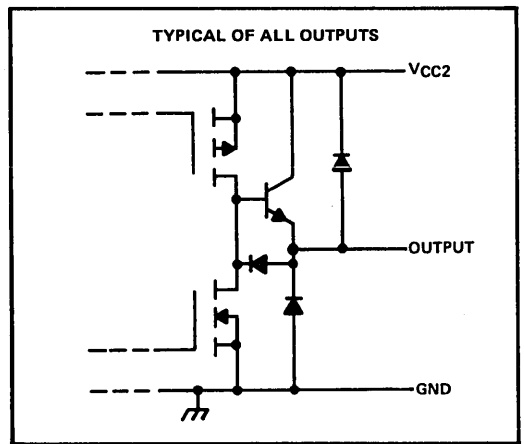
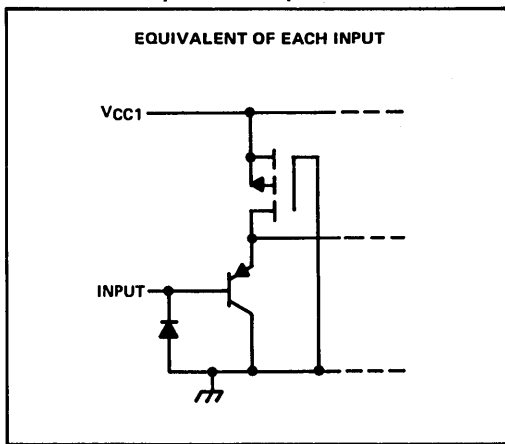

# TYPE SN75511

## VACUUM FLUORESCENT DISPLAY DRIVER

### absolute maximum ratings over operating free-air temperature range (unless otherwise noted)

Supply voltage, $V_{CC1}$ (see Note 1)	15 V
Supply voltage, $V_{CC2}$	60 V
Input voltage	$V_{CC1}$
Continuous total dissipation at (or below) 70°C free-air temperature	650 mW
Operating free-air temperature range	0°C to 70°C
Storage temperature range	-65°C to 150°C
Lead temperature 1/16 inch (1,6 mm) from case for 10 seconds	260°C

NOTE 1: Voltage values are with respect to network ground terminal.

### recommended operating conditions

	MIN	NOM	MAX	UNIT
Supply voltage, $V_{CC1}$	10.8	12	13.2	V
Supply voltage, $V_{CC2}$			60	V
Peak high-level output current			-25	mA
Peak low-level output current			5	mA
Input data rate	0		4	MHz
Width of high clock pulse, $t_{wH}$ (see Figure 1)	125			ns
Width of low clock pulse, $t_{wL}$ (see Figure 1)	125			ns
Data setup time before low-to-high transition of clock, $t_{su}$ (see Figure 1)	125			ns
Data hold time after low-to-high transition of clock, $t_h$ (see Figure 1)	0			ns
Operating free-air temperature, $T_A$	0		70	°C

### electrical characteristics over recommended operating free-air temperature range (unless otherwise noted)

PARAMETER		TEST CONDITIONS	MIN	TYP†	MAX	UNIT
$V_{IH}$	High-level input voltage		7			V
$V_{IL}$	Low-level input voltage				3	V
$V_{IK}$	Input clamp voltage	$V_{CC1} = 12\text{ V}, I_I = -12\text{ mA}$			-1.5	V
$V_{OH}$	High-level output voltage	Q outputs	$V_{CC1} = 10.8\text{ V}, V_{CC2} = 60\text{ V}, I_O = -25\text{ mA}$	55	57.5	V
		Serial data	$V_{CC1} = 12\text{ V}, I_{OH} = -200\text{ }\mu\text{A}$	11	11.3	
$V_{OL}$	Low-level output voltage	Q outputs	$V_{CC1} = 12\text{ V}, I_{OL} = 5\text{ mA}$	1.9	5	V
		Serial data	$V_{CC1} = 12\text{ V}, I_{OL} = 200\text{ }\mu\text{A}$	0.2	0.5	
$I_{IH}$	High-level input current	$V_{CC1} = 13.2\text{ V}, V_I = 7\text{ V}$	0.01	10		$\mu\text{A}$
$I_{IL}$	Low-level input current	$V_{CC1} = 13.2\text{ V}, V_I = 3\text{ V}$	-30	-150		$\mu\text{A}$
$I_{CC1}$	Supply current	$V_{CC1} = 13.2\text{ V}$	$V_I = 7\text{ V}$	150	800	$\mu\text{A}$
			$V_I = 3\text{ V}$	10	12	mA
$I_{CC2}$	Supply current	$V_{CC1} = 13.2\text{ V}, V_{CC2} = 60\text{ V}$	All outputs high	5	8	mA
			Strobe at 7 V	100	500	$\mu\text{A}$

†Typical values are at  $V_{CC1} = 12\text{ V}, T_A = 25^\circ\text{C}$ .

### switching characteristics, $V_{CC1} = 12\text{ V}, V_{CC2} = 60\text{ V}, T_A = 25^\circ\text{C}$

PARAMETER		TEST CONDITIONS	MIN	MAX	UNIT
$t_{DHL}$	Delay time, high-to-low-level output from strobe input	$C_L = 30\text{ pF},$ See Figure 2		500	ns
$t_{DLH}$	Delay time, low-to-high-level output from strobe input			500	ns
$t_{THL}$	Transition time, high-to-low-level output			300	ns
$t_{TLH}$	Transition time, low-to-high-level output			300	ns

9

**TYPE SN75511**  
**VACUUM FLUORESCENT DISPLAY DRIVER**

PARAMETER MEASUREMENT INFORMATION

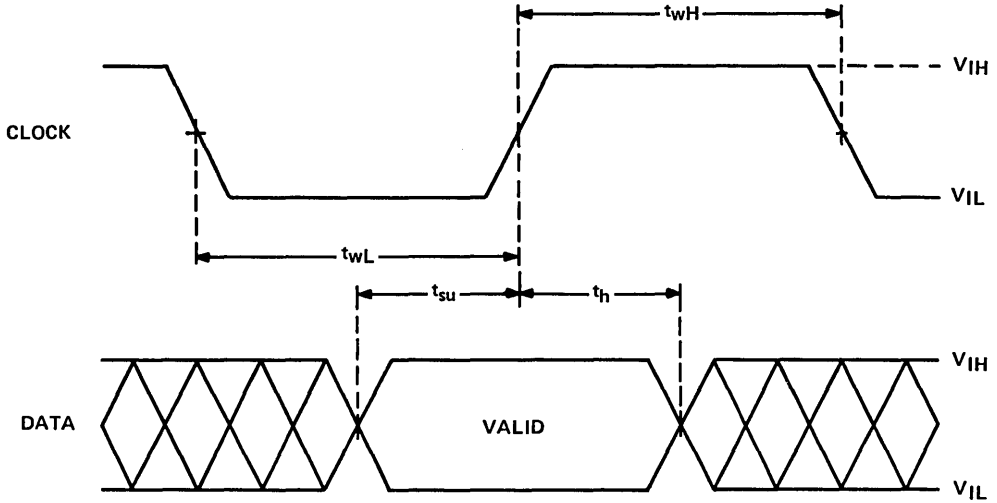

FIGURE 1—INPUT TIMING

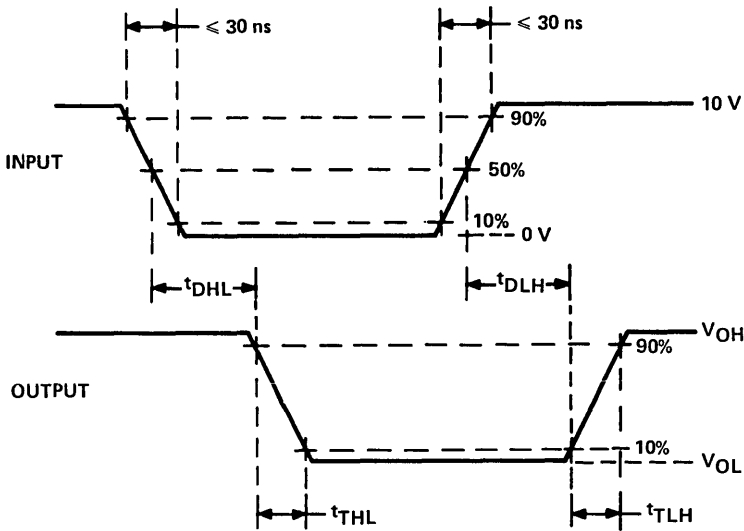

FIGURE 2—OUTPUT SWITCHING TIMES

# INTERFACE CIRCUITS

# TYPE SN75580 HIGH-VOLTAGE 7-SEGMENT LATCH/DECODER/CATHODE DRIVER

D2626, MAY 1981

- Output Current Adjustable From 0.1 mA to 1 mA
- DMOS Outputs for High Breakdown Voltage  
Segment Outputs . . . 100 V Min  
Decimal Point Output . . . 100 V Min
- Input Data Latches
- Blanking Input Provided
- Low Power Requirements
- Supply Voltage Variable over Wide Range . . . 5 V to 15 V
- Decimal Point Output Provided
- Suitable for Multiplex Operation

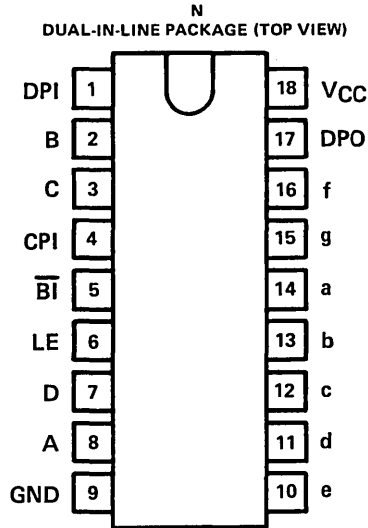

## functional block diagram

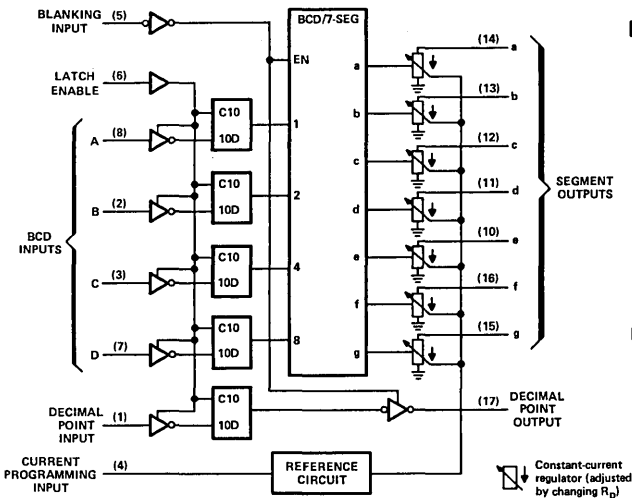

## logic symbol†

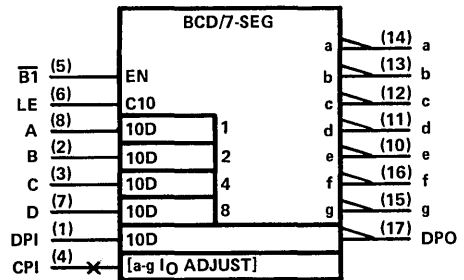

† This symbol is in accordance with IEEE Std 91/ANSI Y32.14 and current discussions in IEC and IEEE.

## description

The SN75580 is designed to decode four lines of BCD data and drive a gas-filled seven-segment display tube such as Beckman and Panaplex II<sup>†</sup> displays. Latches are provided to store the BCD and decimal point data while the enable input is at a low-level voltage.

The design employs a read-only memory to provide output decoding for the BCD digits 0 to 9. For input data greater than BCD 9, the segment outputs are blanked. Each sink output is regulated to ensure a constant brightness of the display even with a fluctuating supply voltage. The on-state output current is essentially constant over the output voltage range of 4 volts to 100 volts. Each current sink is ratioed to the "b" segment output current as required for even illumination of all segments.

<sup>†</sup> Trademark of Burroughs Corporation.

## PRODUCT PREVIEW

Copyright © 1981 by Texas Instruments Incorporated

This document contains information on a product under development. Texas Instruments reserves the right to change or discontinue this product without notice.

**TEXAS INSTRUMENTS**  
INCORPORATED

POST OFFICE BOX 225012 • DALLAS, TEXAS 75265

# TYPE SN75580 HIGH-VOLTAGE 7-SEGMENT LATCH/DECODER/CATHODE DRIVER

## description (continued)

Output currents may be varied from 0.1 mA to 1 mA for driving various displays. The output current is adjusted by connecting an external programming resistor ( $R_p$ ) from the current programming input to ground.

The blanking input provides unconditional blanking of all segment outputs including the decimal point output.

The enable input allows data to be stored internally while input data is changing. When enable is at a high-level voltage, the outputs will reflect conditions on the A, B, C, D, and DP inputs. A transition from a high-level voltage to a low-level voltage at enable will cause the input data set up prior to the transition to be latched. In the latched state, the A, B, C, D, and DP inputs are in a high-impedance state to minimize input loading.

FUNCTION TABLE

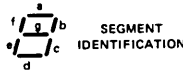

DECIMAL OR FUNCTION	DP INPUT†	BCD INPUTS†				BI	SEGMENT OUTPUTS							DP OUTPUT	DISPLAY
		D	C	B	A		a	b	c	d	e	f	g		
0	X	L	L	L	L	H	ON	ON	ON	ON	ON	ON	OFF	X	0
1	X	L	L	L	H	H	OFF	ON	ON	OFF	OFF	OFF	OFF	X	1
2	X	L	L	H	L	H	ON	ON	OFF	ON	ON	OFF	ON	X	2
3	X	L	L	H	H	H	ON	ON	ON	ON	OFF	OFF	ON	X	3
4	X	L	H	L	L	H	OFF	ON	ON	OFF	OFF	ON	ON	X	4
5	X	L	H	L	H	H	ON	OFF	ON	ON	OFF	ON	ON	X	5
6	X	L	H	H	L	H	ON	OFF	ON	ON	ON	ON	ON	X	6
7	X	L	H	H	H	H	ON	ON	ON	OFF	OFF	OFF	OFF	X	7
8	X	H	L	L	L	H	ON	ON	ON	ON	ON	ON	ON	X	8
9	X	H	L	L	H	H	ON	ON	ON	ON	OFF	ON	ON	X	9
10	X	H	L	H	L	H	OFF	OFF	OFF	OFF	OFF	OFF	OFF	X	Blank
11	X	H	L	H	H	H	OFF	OFF	OFF	OFF	OFF	OFF	OFF	X	Blank
12	X	H	H	L	L	H	OFF	OFF	OFF	OFF	OFF	OFF	OFF	X	Blank
13	X	H	H	L	H	H	OFF	OFF	OFF	OFF	OFF	OFF	OFF	X	Blank
14	X	H	H	H	L	H	OFF	OFF	OFF	OFF	OFF	OFF	OFF	X	Blank
15	X	H	H	H	H	H	OFF	OFF	OFF	OFF	OFF	OFF	OFF	X	Blank
BI	X	X	X	X	X	L	OFF	OFF	OFF	OFF	OFF	OFF	OFF	OFF	Blank
DP	H	X	X	X	X	H	X	X	X	X	X	X	X	ON	DP
DP	L	X	X	X	X	H	X	X	X	X	X	X	X	OFF	DP

H = high level, L = low level, X = irrelevant

† Table is valid for the indicated BCD and decimal point inputs while the latch enable is high. See description.

## absolute maximum ratings over operating free-air temperature range (unless otherwise noted)

Supply voltage, $V_{CC}$ (see Note 1)	18 V
Input voltage	$V_{CC}$
Peak transient off-state voltage, segment outputs (See Note 2)	180 V
Continuous on-state segment output current	4 mA
Peak transient on-state segment output current (See Note 3)	50 mA
Continuous total dissipation	650 mW
Operating free-air temperature range	0°C to 70°C
Storage temperature range	-65°C to 150°C
Lead temperature 1/16 inch (1,6 mm) from case for 10 seconds	260°C

- NOTES: 1. Voltage values are with respect to network ground terminal.  
 2. In all applications, peak transient segment output voltage must be limited to 180 V. This is accomplished by limiting the anode voltage to 180 V maximum.  
 3. In all applications, peak transient segment current must be limited to 50 mA ( $t_w \leq 10 \mu s$ , duty cycle  $\leq 1\%$ ). This may be accomplished in d-c applications by connecting a 2.2 k $\Omega$  resistor from the anode-supply filter capacitor to the display anode, or by current limiting the anode driver in multiplex applications (See Figure 4).

TEXAS INSTRUMENTS  
INCORPORATED

POST OFFICE BOX 225012 • DALLAS, TEXAS 75265



# TYPE SN75580

## HIGH-VOLTAGE 7-SEGMENT LATCH/DECODER/CATHODE DRIVER

**recommended operating conditions**

	MIN	MAX	UNIT
Supply voltage, $V_{CC}$ . . . . .	5	15	V
Segment output voltage . . . . .	4	100	V
Decimal point output voltage . . . . .	4	100	V
Segment-b output current . . . . .	0.1	1	mA
Enable pulse width, $t_W$ (see Figure 2) . . . . .	500		ns
Data setup time before enable goes low (see Figure 2) . . . . .	500		ns
Data hold time after enable goes low (see Figure 2) . . . . .	500		ns
Operating free-air temperature . . . . .	0	70	°C

**electrical characteristics over recommended operating free-air temperature range (unless otherwise noted)**

PARAMETER		TEST CONDITIONS	MIN	TYP	MAX	UNIT	
$V_{IH}$	High-level input voltage	$V_{CC} = 10\text{ V}$	7			V	
$V_{IL}$	Low-level input voltage	$V_{CC} = 10\text{ V}$			3	V	
$V_{IK}$	Input clamp voltage	$V_{CC} = 15\text{ V}$ , $I_I = -12\text{ mA}$ , $T_A = 25^\circ\text{C}$	-0.9		-1.5	V	
$V_{O(on)}$	On-state output voltage	Decimal point $V_{CC} = 5\text{ V}$ , $I_O = 25\text{ mA}$			4	V	
$V_{(BR)off}$	Off-state output breakdown voltage	a thru g	BI at 0 V, $I_O = 3\text{ }\mu\text{A}$		100	V	
		Decimal point			100		
$I_{O(on)b}$	Segment-b on-state output current	$V_{CC} = 10\text{ V}$ , $V_{O(b)} = 50\text{ V}$ , $T_A = 25^\circ\text{C}$	$R_p = 18080\text{ }\Omega$	0.17	0.20	0.23	mA
			$R_p = 7232\text{ }\Omega$	0.425	0.50	0.575	
			$R_p = 3616\text{ }\Omega$	0.85	1.00	1.15	
$I_{O(on)}$	Segment output currents normalized to b-segment current	$V_{CC} = 10\text{ V}$ , All outputs at 50 V, $T_A = 25^\circ\text{C}$	Segments a, f, & g	0.84	0.93	1.02	
			Segment c	1.12	1.25	1.38	
			Segment d	0.9	1.00	1.1	
			Segment e	0.99	1.10	1.21	
$I_{IH}$	High-level input current	All inputs except CPI	$V_{CC} = 10\text{ V}$ , $V_I = 10\text{ V}$		1	$\mu\text{A}$	
$I_{IL}$	Low-level input current	All inputs except CPI	$V_{CC} = 10\text{ V}$ , $V_{CC} = 0\text{ V}$		1	$\mu\text{A}$	
$I_{CC}$	Supply current	$V_{CC} = 15\text{ V}$ , All inputs at 10 V, $R_p$ open		4		mA	
		$V_{CC} = 15\text{ V}$ , All inputs at 0 V, $R_p = 3.6\text{ k}\Omega$		6			

# TYPE SN75580

## HIGH-VOLTAGE 7-SEGMENT LATCH/DECODER/CATHODE DRIVER

switching characteristics,  $V_{CC} = 10\text{ V}$ ,  $T_A = 25^\circ\text{C}$ , see figures 1 and 2

PARAMETER		MIN	TYP	MAX	UNIT
$t_{off}$	Turn-off time of segment outputs from BCD inputs		0.5	10	$\mu\text{s}$
$t_{on}$	Turn-on time of segment outputs from BCD inputs		0.5	10	
$t_{off}$	Turn-off time of segment outputs from DP input		0.5	10	$\mu\text{s}$
$t_{on}$	Turn-on time of segment outputs from DP input		0.5	10	
$t_{off}$	Turn-off time of segment outputs from BI		0.5	10	$\mu\text{s}$
$t_{on}$	Turn-on time of segment outputs from BI		0.5	10	

### PARAMETER MEASUREMENT INFORMATION

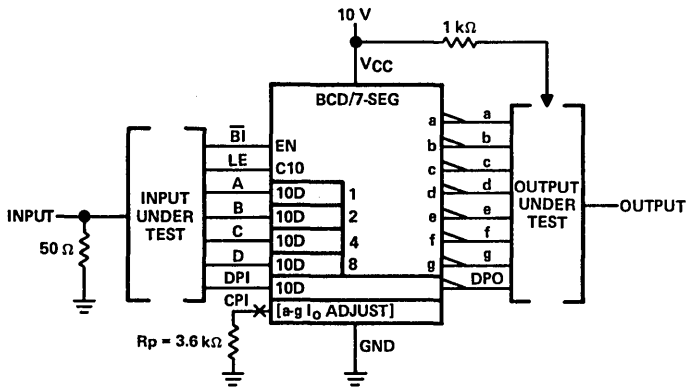

FIGURE 1—TEST CIRCUIT

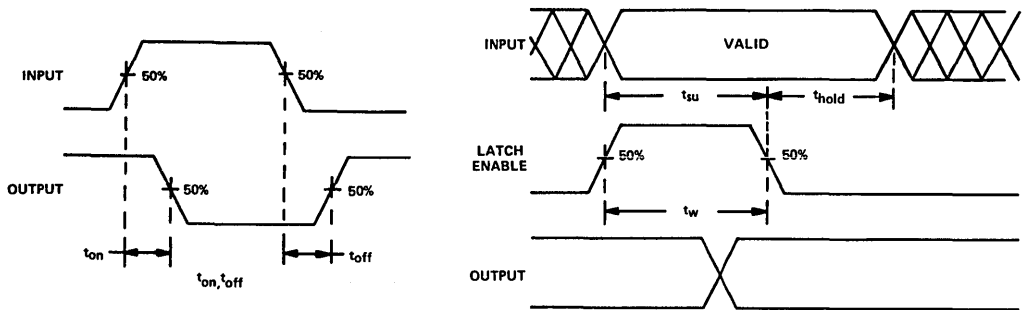

FIGURE 2—VOLTAGE WAVEFORMS

# TYPE SN75580 HIGH-VOLTAGE 7-SEGMENT LATCH/DECODER/CATHODE DRIVER

## TYPICAL CHARACTERISTICS

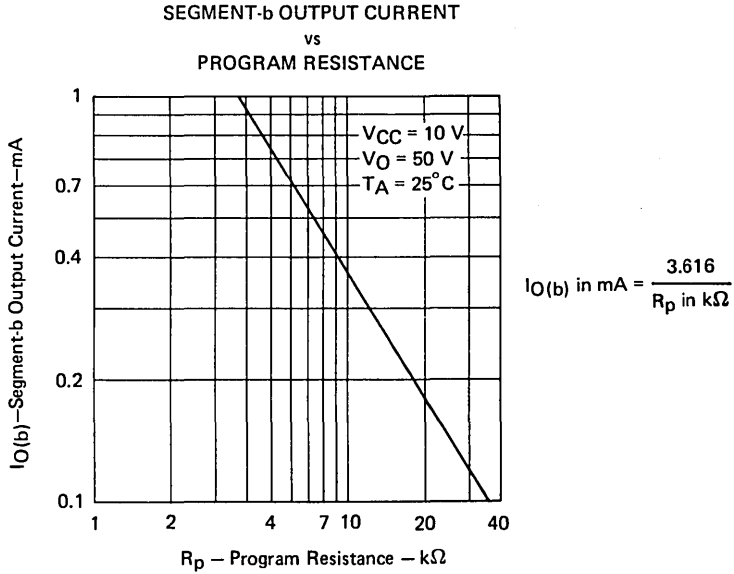

FIGURE 3

## TYPICAL APPLICATION DATA

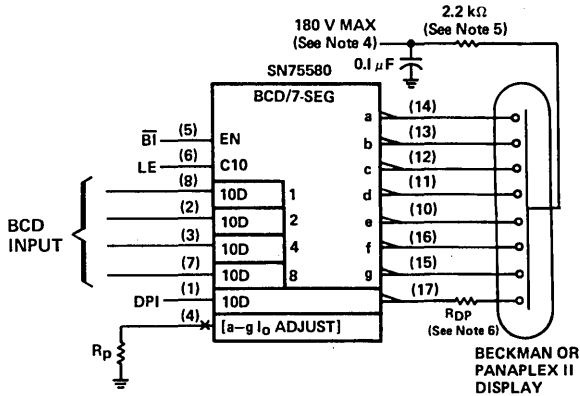

FIGURE 4—SINGLE-DIGIT 7-SEGMENT DISPLAY

- NOTES: 4. This voltage must be adjusted for the type of display used to ensure that the on-state and off-state voltages do not exceed 100 V at the segment outputs of the SN75580.
5. In all applications, peak transient segment current must be limited to 50 mA ( $t_w < 10 \mu s$ , duty cycle  $< 1\%$ ). This may be accomplished in d-c applications by connecting a 2.2-k $\Omega$  resistor from the anode-supply filter capacitor to the display anode, or by current limiting the anode driver in multiplex applications.
6. The value of  $R_{DP}$  is chosen for even illumination of the decimal point and the digit.

**TEXAS INSTRUMENTS**  
INCORPORATED

POST OFFICE BOX 225012 • DALLAS, TEXAS 75265



## INTERFACE CIRCUITS

# TYPE SN75584A HIGH-VOLTAGE 7-SEGMENT LATCH/DECODER/CATHODE DRIVER

D2627, MAY 1981

- Output Current Adjustable From 0.1 mA to 4 mA
- DMOS Outputs for High Breakdown Voltage  
Segment Outputs . . . 100 V Min  
Decimal Point Output . . . 100 V Min
- Input Data Latches
- Blanking Input Provided
- P-N-P Inputs for Minimal Input Loading
- Low Power Requirements
- Thermal Protection Circuitry
- Supply Voltage Variable Over Wide Range . . . 4.75 V to 15 V
- Decimal Point Output Provided
- Suitable for Multiplex Operation

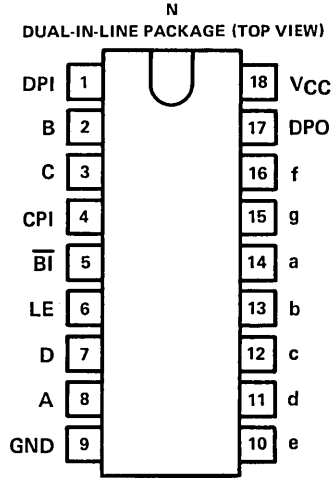

functional block diagram

logic symbol †

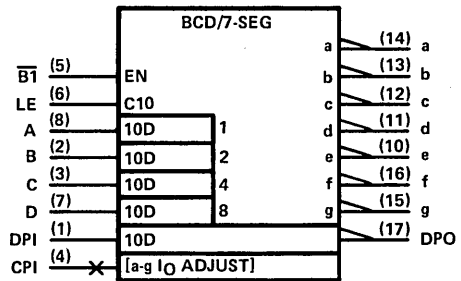
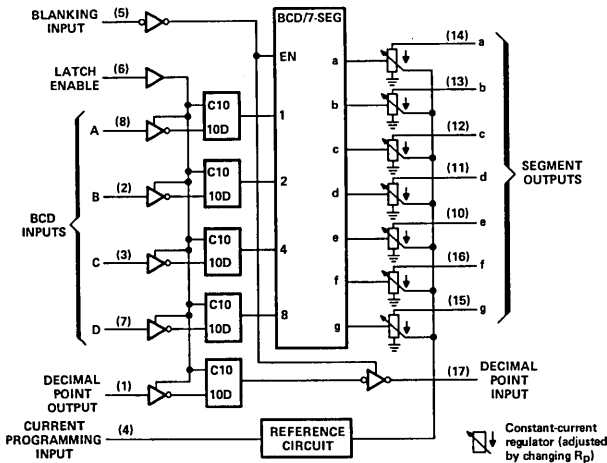

† This symbol is in accordance with IEEE Std 91/ANSI Y32.14 and current discussions in IEC and IEEE.

## description

The SN75584A is designed to decode four lines of BCD data and drive a gas-filled seven-segment display tube such as Beckman and Panplex II<sup>†</sup> displays. Latches are provided to store the BCD and decimal point data while the enable input is at a low-level voltage.

The design employs a read-only memory to provide output decoding for the BCD digits 0 to 9. For input data greater than BCD 9, the segment outputs are blanked. Each sink output is regulated to ensure a constant brightness of the display even with a fluctuating supply voltage. The on-state output current is essentially constant over the output voltage range of 4 volts to 100 volts. Each current sink is ratioed to the "b" segment output current as required for even illumination of all segments.

<sup>†</sup>Trademark of Burroughs Corporation.

Copyright © 1981 by Texas Instruments Incorporated

**TEXAS INSTRUMENTS**  
INCORPORATED

POST OFFICE BOX 225012 • DALLAS, TEXAS 75265

# TYPE SN75584A

## HIGH-VOLTAGE 7-SEGMENT LATCH/DECODER/CATHODE DRIVER

### description (continued)

Output currents may be varied from 0.1 mA to 4 mA for driving various displays. The output current is adjusted by connecting an external programming resistor ( $R_p$ ) from the current programming input to ground.

The blanking input provides unconditional blanking of all segment outputs including the decimal point output.

The enable input allows data to be stored internally while input data is changing. When enable is at a high-level voltage, the outputs will reflect conditions on the A, B, C, D, and DP inputs. A transition from a high-level voltage to a low-level voltage at enable will cause the input data set up prior to the transition to be latched. In the latched state, the A, B, C, D, and DP inputs are in a high-impedance state to minimize input loading.

Thermal protection circuitry will blank the display, regardless of input conditions, whenever junction temperature exceeds approximately 150°C.

FUNCTION TABLE

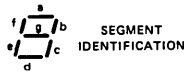

DECIMAL OR FUNCTION	DP INPUT†	BCD INPUTS†				BI	SEGMENT OUTPUTS							DP OUT-PUT	DISPLAY
		D	C	B	A		a	b	c	d	e	f	g		
		0	X	L	L		L	L	H	ON	ON	ON	ON		
1	X	L	L	L	H	H	OFF	ON	ON	OFF	OFF	OFF	OFF	X	1
2	X	L	L	H	L	H	ON	ON	OFF	ON	ON	OFF	ON	X	2
3	X	L	L	H	H	H	ON	ON	ON	ON	OFF	OFF	ON	X	3
4	X	L	H	L	L	H	OFF	ON	ON	OFF	OFF	ON	ON	X	4
5	X	L	H	L	H	H	ON	OFF	ON	ON	OFF	ON	ON	X	5
6	X	L	H	H	L	H	ON	OFF	ON	ON	ON	ON	ON	X	6
7	X	L	H	H	H	H	ON	ON	ON	OFF	OFF	OFF	OFF	X	7
8	X	H	L	L	L	H	ON	ON	ON	ON	ON	ON	ON	X	8
9	X	H	L	L	H	H	ON	ON	ON	ON	OFF	ON	ON	X	9
10	X	H	L	H	L	H	OFF	OFF	OFF	OFF	OFF	OFF	OFF	X	10
11	X	H	L	H	H	H	OFF	OFF	OFF	OFF	OFF	OFF	OFF	X	11
12	X	H	H	L	L	H	OFF	OFF	OFF	OFF	OFF	OFF	OFF	X	12
13	X	H	H	L	H	H	OFF	OFF	OFF	OFF	OFF	OFF	OFF	X	13
14	X	H	H	H	L	H	OFF	OFF	OFF	OFF	OFF	OFF	OFF	X	14
15	X	H	H	H	H	H	OFF	OFF	OFF	OFF	OFF	OFF	OFF	X	15
BI	X	X	X	X	X	L	OFF	OFF	OFF	OFF	OFF	OFF	OFF	OFF	OFF
DP	H	X	X	X	X	H	X	X	X	X	X	X	X	ON	
DP	L	X	X	X	X	H	X	X	X	X	X	X	X	OFF	

H = high level, L = low level, X = irrelevant

† Table is valid for the indicated BCD and decimal point inputs while enable is high. See description.

### absolute maximum ratings over operating free-air temperature range (unless otherwise noted)

Supply voltage, $V_{CC}$ (see Note 1)	18 V
Input voltage	$V_{CC}$
Peak transient off-state voltage, segment outputs (See Note 2)	180 V
Continuous on-state segment output current	4 mA
Peak transient on-state segment output current (See Note 3)	50 mA
Continuous total dissipation	650 mW
Operating free-air temperature range	0°C to 70°C
Storage temperature range	-65°C to 150°C
Lead temperature 1/16 inch (1,6 mm) from case for 10 seconds	260°C

NOTES: 1. Voltage values are with respect to network ground terminal.

2. In all applications, peak transient segment output voltage must be limited to 180 V. This is accomplished by limiting the anode voltage to 180 V maximum.

3. In all applications, peak transient segment current must be limited to 50 mA ( $t_w < 10 \mu s$ , duty cycle  $\leq 1\%$ ). This may be accomplished in d-c applications by connecting a 2.2 k $\Omega$  resistor from the anode-supply filter capacitor to the display anode, or by current limiting the anode driver in multiplex applications (see Figure 4).

# TYPE SN75584A

## HIGH-VOLTAGE 7-SEGMENT LATCH/DECODER/CATHODE DRIVER

### recommended operating conditions

	MIN	MAX	UNIT
Supply voltage, $V_{CC}$	4.75	15	V
Segment output voltage	4	100	V
Decimal point output voltage	0	100	V
Segment-b output current	0.1	4	mA
Enable pulse width, $t_W$ (see Figure 2)	500		ns
Data setup time before enable goes low (see Figure 2)	500		ns
Data hold time after enable goes low (see Figure 2)	500		ns
Operating free-air temperature	0	70	°C

### electrical characteristics over recommended operating free-air temperature range (unless otherwise noted)

PARAMETER		TEST CONDITIONS		MIN	TYP	MAX	UNIT				
$V_{IH}$	High-level input voltage			2			V				
$V_{IL}$	Low-level input voltage					0.8	V				
$V_{IK}$	Input clamp voltage	$V_{CC} = 15\text{ V}$ ,	$I_I = -12\text{ mA}$ ,	$T_A = 25^\circ\text{C}$		-0.9 -1.5	V				
$V_{(BR)off}$	Off-state output breakdown voltage	a thru g	BI at 0 V,	$I_O = 3\ \mu\text{A}$		100	V				
	Decimal point					100					
$I_{O(on)b}$	Segment-b on-state output current	$V_{CC} = 10\text{ V}$ ,	$V_{O(b)} = 50\text{ V}$ ,	$T_A = 25^\circ\text{C}$	$R_p = 18080\ \Omega$	0.18	0.20	0.22	mA		
					$R_p = 7232\ \Omega$	0.45	0.50	0.55			
					$R_p = 2411\ \Omega$	1.35	1.5	1.65			
					$R_p = 1808\ \Omega$	1.8	2.0	2.2			
					$R_p = 1205\ \Omega$	2.7	3.0	3.3			
					$R_p = 904\ \Omega$	3.6	4.0	4.4			
		$V_{CC} = 5\text{ V to }15\text{ V}$ ,	$V_{O(b)} = 10\text{ V to }100\text{ V}$ ,	$T_A = 0^\circ\text{C to }70^\circ\text{C}$	$R_p = 18080\ \Omega$	0.16		0.24			
					$R_p = 7232\ \Omega$		0.4	0.6			
					$R_p = 2411\ \Omega$		1.2	1.8			
					$R_p = 1808\ \Omega$		1.6	2.4			
					$R_p = 1205\ \Omega$		2.4	3.6			
					$R_p = 904\ \Omega$		3.2	4.8			
$I_{O(on)}$	Segment output currents normalized to b-segment current	Segments a, f, & g	$V_{CC} = 10\text{ V}$ ,	All outputs at 50 V,	$T_A = 25^\circ\text{C}$		0.84	0.93	1.02		
		Segment c					1.12	1.25	1.38		
		Segment d					0.9	1.00	1.1		
		Segment e					0.99	1.10	1.21		
		Segments a, f, & g				$V_{CC} = 5\text{ V to }15\text{ V}$ ,	All outputs at 10 V to 100 V,	$T_A = 0^\circ\text{C to }70^\circ\text{C}$		0.74	1.12
		Segment c								1	1.5
		Segment d								0.8	1.2
		Segment e								0.88	1.32
$I_{IH}$	High-level input current	All inputs	$V_{CC} = 15\text{ V}$ ,	$V_I = 15\text{ V}$	Enable at 15 V		15	$\mu\text{A}$			
		A, B, C, D, & DP			Enable at 0 V		1				
$I_{IL}$	Low-level input current	All inputs	$V_{CC} = 15\text{ V}$ ,	$V_I = 0.4\text{ V}$	Enable at 15 V		-50	$\mu\text{A}$			
		Enable			Enable at 0.4 V		-50				
		A, B, C, D, & DP			Enable at 0 V		-1				
$I_{CC}$	Supply current	$V_{CC} = 15\text{ V}$ ,	All inputs at 15 V,	$R_p$ open			4	mA			
		$V_{CC} = 15\text{ V}$ ,			All inputs at 0 V,	$R_p = 2.2\text{ k}\Omega$				6	

9

# TYPE SN75584A

## HIGH-VOLTAGE 7-SEGMENT LATCH/DECODER/CATHODE DRIVER

switching characteristics,  $V_{CC} = 5\text{ V}$ ,  $T_A = 25^\circ\text{C}$ , see figures 1 and 2

PARAMETER		MIN	TYP	MAX	UNIT
$t_{off}$	Turn-off time of segment outputs from BCD inputs		0.5	10	$\mu\text{s}$
$t_{on}$	Turn-on time of segment outputs from BCD inputs		0.5	10	
$t_{off}$	Turn-off time of segment outputs from DP input		0.5	10	$\mu\text{s}$
$t_{on}$	Turn-on time of segment outputs from DP input		0.5	10	
$t_{off}$	Turn-off time of segment outputs from BI		0.5	10	$\mu\text{s}$
$t_{on}$	Turn-on time of segment outputs from BI		0.5	10	

### PARAMETER MEASUREMENT INFORMATION

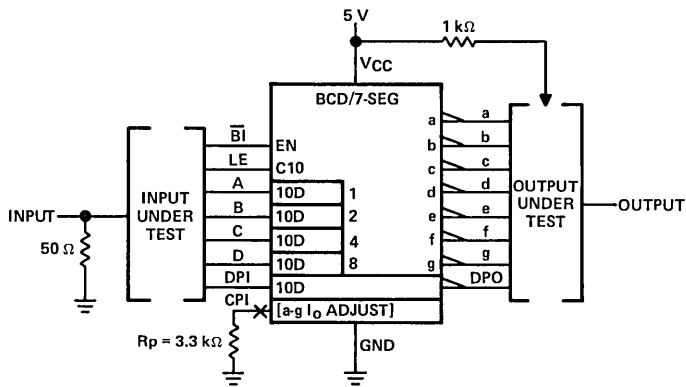

FIGURE 1 – TEST CIRCUIT

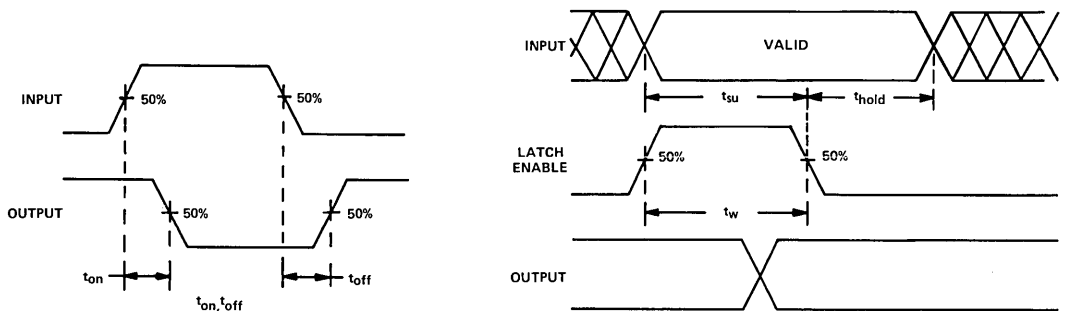
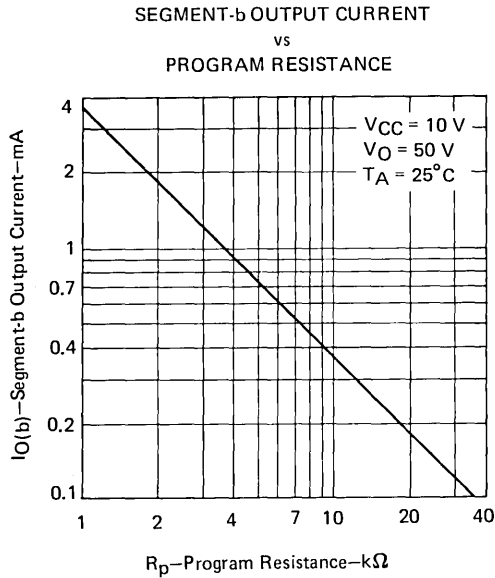

FIGURE 2—VOLTAGE WAVEFORMS



# TYPE SN75584A HIGH-VOLTAGE 7-SEGMENT LATCH/DECODER/CATHODE DRIVER

## TYPICAL CHARACTERISTICS



$$I_O(b) \text{ in mA} = \frac{3.616}{R_p \text{ in k}\Omega}$$

FIGURE 3

## TYPICAL APPLICATION DATA

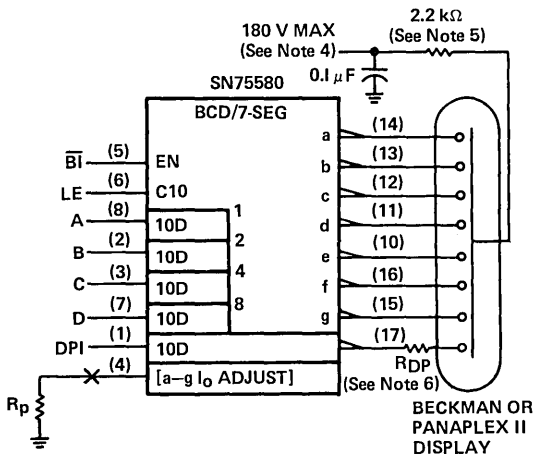

FIGURE 4—SINGLE-DIGIT 7-SEGMENT DISPLAY

- NOTES: 4. This voltage must be adjusted for the type of display used to ensure that the on-state and off-state voltages do not exceed 100 V at the segment outputs of the SN75584A.
5. In all applications, peak transient segment current must be limited to 50 mA ( $t_w \leq 10 \mu\text{s}$ , duty cycle  $\leq 1\%$ ). This may be accomplished in d-c applications by connecting a 2.2-k $\Omega$  resistor from the anode-supply filter capacitor to the display anode, or by current limiting the anode driver in multiplex applications.
6. The value of  $R_{DP}$  is chosen as required for even illumination of the decimal point and the digit.



**JAN MIL-M-38510**  
**Integrated Circuits**

# MILITARY PRODUCTS

## MIL-M-38510 AND MIL-STD-883 Military High-Reliability Integrated Circuits

The Texas Instruments MIL-M-38510 and MIL-STD-883 programs offer several options designed to meet system cost, reliability, lead time, and contract requirements. The following are the key features of the options available for MIL-M-38510 and MIL-STD-883 Class B applications:

### JAN-Processed TI SNJ

- Produced under MIL-M-38510 guidelines with all chips manufactured in a DESC-certified front end facility
- Fully tested per MIL-STD-883 method 5004 Class B
- Includes device types covered by MIL-M-38510 part numbers and circuits not yet covered by MIL numbers
- Electrical and mechanical characteristics per TI data sheets
- Marked with 38510 part numbers where applicable
- Each lot includes Certificate of Conformance and Group A Summary Report
- Approximately one-half the cost of JAN-Qualified IC's

### SNC/MACH-IV (883B)

- Cost effective – approximately one-third the cost of JAN-Qualified IC's
- Produced under MIL-M-38510 guidelines with all chips manufactured in a DESC-certified front end facility
- Tested per MIL-STD-883 method 5004 Class B and TI 38510/MACH-IV specification, Section 9 of this catalog
- Tested per MIL-STD-883 method 5004 Class B and TI 38510/MACH-IV specification, Section 9 of this catalog
- Electrical and mechanical characteristics per TI data sheets
- Available in broad product spectrum including SSI, MSI, and LSI, both bipolar and MOS

### JAN-Qualified

- Qualified per MIL-M-38510 Class B
- Produced per MIL-STD-883 and MIL-M-38510 Class B and appropriate slash sheets
- Produced in DESC-certified domestic production facility
- Applicable devices and packages

PRODUCT	A	C	D	E	F	G	I	J	L	T	V	W
SERIES 54 TTL	X	X	X	X	X			X	X			
SERIES 54H TTL	X	X	X	X								
SERIES 54L TTL*										X		
SERIES 54LS TTL	X	X	X	X	X			X	X			
SERIES 54S TTL	X	X	X	X	X			X	X			
LINEAR CONTROL	X					X	X					
SERIES 55 INTERFACE	X		X									
MOS LSI										X	X	X
LEAD FINISH B	X	X	X	X				X	X		X	X
LEAD FINISH C/D						X	X			X		X

\* PER MIL-M-0038510B, Class S.

## How to Order

See Tables I, II and III for device, package and lead-finish cross-reference.

<b>• JAN-Processed/TI SNJ</b>					
Device type covered by 38510 part number:		Device type not covered by 38510 part number:			
Device	SN5400J	883 Class B	Device	SN54LS298J	883 Class B
Order	SNJ5400J		Order	SNJ54LS298J	
Marking	{ SNJ5400J 38510/00104BCB		Marking	{ SNJ54LS298J 38510B	

<b>• SNC/MACH-IV</b>			
Device	SNC5400J	883 Class B	
Order	SNC5400J		
Marking	SNC5400J		

<b>• JAN-Qualified</b>			
Device	SN5400J	883 Class B	
Order	JM38510/00104BCB		
Marking	JM38510/00104BCB		

**Table I Part Numbers**  
 EXAMPLE: 5400 TTL NAND gate in ceramic dual-in-line package to 883 Class B with standard tin-plated leads.

- JAN QUALIFIED
- JAN PROCESSED/TI SNJ
- SNC/MACH-IV

MIL-STD-883  
CLASS B SCREENING ONLY

MIL-M-38510 SLASH SHEET  
AND DEVICE TYPE  
SEE TABLE II & III

JAN	PACKAGE	SNJ SNC/MACH-IV
A	1/4" x 1/4" FLAT-14	U/FB
B/T*	1/4" x 1/8" FLAT-14	T
C	DIP-14	J
D	1/4" x 3/8" FLAT-14	W
E	DIP-16	J
F	1/4" x 3/8" FLAT-16	W/SB
G	T0-99	L
H	1/4" x 1/4" FLAT-10	U
I	T0-100	L
J	DIP-24	J
K	3/8" x 5/8" FLAT-24	W
L	3/8" x 1/2" FLAT-24	W
V	DIP-18	JR §
W	DIP-22	JR §
X	T0-5	—
Y	T0-3	—
Z	1/4" X 3/8" FLAT-24	—

JAN	TYPE	SNJ SNC/MACH-IV
A	SOLDER DIP	10
B	TIN-PLATE	00
C/D*	GOLD-PLATE	00†
X	OPTIONAL**	

\*Per MIL-M-0038510B, Class S.

\*\*Finish B or C at TI's option. Devices will be marked B or C as applicable.

†Prefix designation for MOS/LSI is "SMC."

§R denotes temperature range.

# MILITARY PRODUCTS

## Screening — Class B

SCREEN	JAN QUALIFIED		SNJ JAN PROCESSED		SNC MACH-IV	
	METHOD	RQMT	METHOD	RQMT	METHOD	RQMT
Internal Visual (Precap)	2010.2 Cond B and 38510	100%	2010.2 Cond B and 38510	100%	2010.2 Cond B and 38510	100%
Stabilization Bake	1008.1 24 hrs min test Cond C	100%	1008.1 24 hrs min test Cond C	100%	1008.1 24 hrs min test Cond C	100%
Temperature Cycling	1010.1 Cond C	100%	1010.1 Cond C	100%	1010.1 Cond C	100%
Constant Acceleration	2001.1 Cond E (min) in Y <sub>1</sub> plane	100%	2001.1 Cond E (min) in Y <sub>1</sub> plane	100%	2001.1 Cond E (min) in Y <sub>1</sub> plane	100%
Seal (a) Fine (b) Gross	1014.1	100%	1014.1	100%	1014.1 (cond C <sub>1</sub> )	100%
Interim Electrical	JAN slash-sheet electrical specifications	As applicable	TI data sheet electrical specifications	As applicable	TI data sheet electrical specifications	As applicable
Burn-in test	1015.1 160 hrs @ 125°C min	100%	1015.1 160 hrs @ 125°C min	100%	1015.1 160 hrs @ 125°C min	100%
Final Electrical Tests (a) Static tests (1) 25°C (Subgroup 1, table 1, 5005.3) (2) Max and min rated op. temperature (subgroups 2 and 3, table 1, 5005.3) (b) Dynamic tests and switching tests 25°C (subgroup 4 and 9, table 1, 5005.3) (c) Functional test 25°C (subgroup 7, table 1, 5005.3)	JAN slash-sheet electrical specifications	100%  100%  100%	TI data sheet electrical specifications	100%  100%  100%	TI data sheet electrical specifications	100%  100% Note 1  100%
Qualification or quality conformance inspection	5005.3 Class B	per 38510	5005.3 Class B	per 38510 Note 2	5005.3 Class B	per 38510 Note 2
External Visual	2009.1	100%	2009.1	100%	2009.1	100%

NOTES: 1. Temperature guardband test may be used in lieu of 100% test for digital bipolar only.  
2. Group A per 5005.3. Generic data available for groups B, C, and D.

## For MIL-M-38510/MIL-STD-883 Class A/S

For critical space and satellite applications, SAMSO Class S JAN-Qualified TTL flat pack devices are available per MIL-M-0038510B including:

CIRCUIT TYPE	JAN NO.
SN54L00T	JM38510/02004STD
SN54L01T	JM38510/02006STD
SN54L02T	JM38510/02701STD
SN54L04T	JM38510/02005STD
SN54L10T	JM38510/02003STD
SN54L20T	JM38510/02002STD
SN54L30T	JM38510/02001STD
SN54L51T	JM38510/04101STD

CIRCUIT TYPE	JAN NO.
SN54L54T	JM38510/04104STD
SN54L71T	JM38510/02101STD
SN54L74T	JM38510/02105STD
SN54L78T	JM38510/02104STD
SN54L86T	JM38510/02601STD
SN54L91T	JM38510/02806STD
SN54L95T	JM38510/02801STD
SN54L121T	JM38510/04201STD
SN54L122T	JM38510/04202STD
SN54L164T	JM38510/02802STD
SN5400T	JM38510/00104STD
SN5401T	JM38510/00107STD

CIRCUIT TYPE	JAN NO.
SN5402T	JM38510/00401STD
SN5404T	JM38510/00105STD
SN5410T	JM38510/00103STD
SN5420T	JM38510/00102STD
SN5440T	JM38510/00301STD
SN5472T	JM38510/00201STD
SN5473T	JM38510/00202STD
SN5474T	JM38510/00205STD
SN5493T	JM38510/01302STD
SN5495T	JM38510/00901STD
SN54121T	JM38510/01201STD
SN54H00T	JM38510/02304STD

# MILITARY PRODUCTS

TABLE I. JAN INTEGRATED CIRCUITS AND CIRCUIT-TYPE CROSS-REFERENCE

JAN /NO.	CKT TYPE	JAN /NO.	CKT TYPE	JAN /NO.	CKT TYPE	JAN /NO.	CKT TYPE
00101	5430	01307	5490	03001	15930	06005	10507‡
00102	5420	01308	54192	03002	15935	06006	10509‡
00103	5410	01309	54193	03003	15936	06101	10531‡
00104	5400	01310†	54196	03004	15946	06102	10631‡
00105	5404	01311†	54197	03005	15962	06103	10576‡
00106	5412	01312†	54177	03101	15932	06104	10535‡
00107	5401	01401	54150	03102	15944	06201	10504
00108	5405	01402	9312‡	03103	15957	06202	10597
00109	5403	01403	54153	03104	15958	07001	54S00
00201	5472	01404	9309	03105	15933	07002	54S03
00202	5473	01405	54157	03201	15951	07003	54S04
00203	54107	01406	54151	03301	15945	07004	54S05
00204	5476	01501	5475	03302	15948	07005	54S10
00205	5474	01502	5477	03303	15950	07006	54S20
00206	5470	01503	54116	03304	9094	07007	54S22
00207	5479‡	01504	9314‡	03501	MH0026	07008	54S30
00301	5440	01601	5408	04001	54H50	07009	54S133
00302	5437	01602	5409	04002	54H51	07010	54S134
00303	5438	01701	54174	04003	54H53	07101	54S74
00401	5402	01702	54175	04004	54H54	07102	54S112
00402	5423	01703†	54173	04005	54H55	07103	54S113
00403	5425	01801	54170	04101	54L51	07104	54S114
00404	5427	01901	54180	04102	54L54	07105	54S174
00501	5450	02001	54L30	04103	54L55	07106	54S175
00502	5451	02002	54L20	04104♦	54L54	07201	54S40
00503	5453	02003	54L10	04201	54L121	07301	54S02
00504	5454	02004	54L00	04202	54L122	07401	54S51
00601	5482	02005	54L04	04301	93L18	07402	54S64
00602	5483	02006	54L01/54L03	04401	93L24	07403	54S65
00603	9304‡	02101	54L71	04501†	93L14	07501	54S86
00604	5480	02102	54L72	04502†	93L08	07502	54S135
00701	5486	02103	54L73	04601	93L09	07601†	54S194
00801	5406	02104	54L78	04602	93L12	07602†	54S195
00802	5416	02105	54L74	04603	93L22	07701†	54S138
00803	5407	02201	54H72	05001	4011A	07702†	54S139
00804	5417	02202	54H73	05002	4012A	07703†	54S280
00805	5426	02203	54H74	05003	4023A	07801	54S181
00901	5495	02204	54H76	05101	4013A	07802	54S182
00902	5496	02205	54H101	05102	4027A	07901	54S151
00903	54164	02206	54H103	05201	4000A	07902	54S153
00904	54165	02301	54H30	05202	4001A	07903	54S157
00905	54194	02302	54H20	05203	4002A	07904	54S158
00906	54195	02303	54H10	05204	4025A	07905	54S251
00907†	9300‡	02304	54H00	05301	4007A	07906	54S257
00908†	9328	02305	54H04	05302	4019A	07907	54S258
00909†	54198	02306	54H01	05303	4030A	08001	54S11
00910†	54166	02307	54H22	05401	4008A	08002	54S15
01001	5442	02401	54H40	05501	4009A	08003†	54S08
01002	5443	02501	54L90	05502	4010A	08004†	54S09
01003	5444	02502	54L93	05503	4049A	08101	54S140
01004	5445	02503	54L193	05504	4050A	08201	54S85
01005	54145	02504	93L10	05505	4041A	10101	uA741
01006	5446	02505	93L16	05601	4017A	10102	uA747
01007	5447	02601	54L86	05602	4018A	10103	LM101A
01008	5448	02701	54L02	05603	4020A	10104	LM108A
01009	5449	02801	54L95	05604	4022A	10105	LH2101A
01101	54181	02802	54L164	05605	4024A	10106	LH2108A
01102	54182	02803	93L28‡	05701	4006A	10107	LM118
01201	54121	02804	93L00	05702	4014A	10201	uA723
01202	54122	02805	76L70	05703	4015A	10202†	LM104
01203	54123	02806♦	54L91	05704	4021A	10203†	LM105
01204	9601	02901	54L42	05705	4031A	10301	uA710
01205	9602	02902	54L43	05706	4034A	10302	uA711
01301	5492	02903	54L44	05801†	4016A	10303	LM106
01302	5493	02904	54L46	06001	10501‡	10304	LM111
01303	54160	02905	54L47	06002	10502‡	10305†	LM2111
01304	54163	02906	76L42A	06003	10505‡	10401	55107
01305	54162	02907	93L01	06004	10506‡	10402	55108
01306	54161						

NOTE: Only the basic JAN and commercial numbers are shown.

† Slash sheets not released as of date of this publication.

‡ Not recommended for new designs.

♦ Class S only.

# MILITARY PRODUCTS

TABLE I. JAN INTEGRATED CIRCUITS AND CIRCUIT-TYPE CROSS-REFERENCE

JAN. /NO.	CKT TYPE	JAN. /NO.	CKT TYPE	JAN. /NO.	CKT TYPE	JAN. /NO.	CKT TYPE
10403	55114	15802	9317	30104	54LS113	31001	54LS11
10404	55115	15901	9300	30105	54LS114	31002	54LS15
10405	55113	15902	9328	30106	54LS174	31003	54LS21
10406	7831	16001	9334	30107	54LS175	31004	54LS08
10407	7832	16101	5432	30108	54LS107	31101	54LS85
10501†	uA733	16201	5428	30109	54LS109	31201†	54LS83A
10601	LM102‡	20101	54186 (PROM 512)	30110	54LS76	31202†	54LS283
10602	LM110	20102	MCM5304‡	30201	54LS40	31301	54LS13
10603†	LM2110	20103†	IM5603A	30202	54LS37	31302	54LS14
10701	LM109	20201†	IM5603 (PROM 1024)	30203	54LS38	31303	54LS132
10702†	LM140-12	20202†	IM5623	30204	54LS28	31401†	54LS123
10703†	LM140-15	20301†	AM27S10	30301	54LS02	31402†	54LS221
10704†	LM140-24	20302†	AM27S11	30302	54LS27	31403†	54LS122
10801	3018A	20401†	IM5604	30303	54LS266	31501†	54LS90
10802	3045	20402†	IM5624	30401	54LS51	31502†	54LS93
10901†	SE555	20501†	HHX7620-8	30402	54LS54	31503†	54LS160
10902†	SE556	20502†	HMX7621-8	30501	54LS32	31504†	54LS161
15001	5485	20601†	HMX7640-8	30502	54LS86	31505†	54LS168
15101	5413	20602†	HMX7641-8	30601†	54LS194	31506†	54LS169
15102	5414	23001†	93410 (256 RAM)	30602†	54LS195	31507†	54LS192
15103	54132	23002†	93411 (256 RAM)	30603†	54LS95	31508†	54LS193
15201	54154	23003†	93421	30604†	54LS96	31509†	54LS191
15202	54155	23501	TMS4060 (4K RAM)	30605†	54LS164	31510†	54LS92
15203	54156	23502	TMS4050 (4K RAM)	30606†	54LS295	31511†	54LS162
15204	8250	23503	TMS4060 (4K RAM)	30607†	54LS395	31512†	54LS163
15205	8251	23504	TMS4050 (4K RAM)	30701†	54LS138	31513†	54LS190
15206	8252	30001	54LS00	30702†	54LS139	31601†	54LS75
15301	54125	30002	54LS03	30703†	54LS42	31602†	54LS279
15302	54126	30003	54LS04	30704†	54LS47	31701†	54LS124
15401†	54120	30004	54LS05	30801	54LS181	31702†	54LS324
15501	54H08	30005	54LS10	30901†	54LS151	31801†	54LS261
15502	54H11	30006	54LS12	30902†	54LS153	31901†	54LS670
15503	54H21	30007	54LS20	30903†	54LS157	32001†	54LS196
15601	54147	30008	54LS22	30904†	54LS158	32002†	54LS197
15602	54148	30009	54LS30	30905†	54LS251	32003†	54LS290
15603	9318†	30101	54LS73	30906†	54LS257	32004†	54LS293
15701	9338	30102	54LS74	30907†	54LS258	32102†	54LS26
15801	9321	30103	54LS112	30908†	54LS253		

NOTE: Only the basic JAN and commercial numbers are shown.

† Slash sheets not released as of date of this publication.

‡ Not recommended for new designs.



# MILITARY PRODUCTS

TABLE II. CIRCUIT-TYPE AND JAN INTEGRATED CIRCUITS CROSS-REFERENCE

TTL 54 SERIES		CKT TYPE	JAN /NO.	TTL 54L SERIES		CKT TYPE	JAN /NO.
CKT TYPE	JAN /NO.			CKT TYPE	JAN /NO.		
5400	00104	54132	15103	54L00	02004	54LS32	30501
5401	00107	54145	01005	54L01	02006	54LS37	30202
5402	00401	54147	15601	54L02	02701	54LS38	30203
5403	00109	54148	15602	54L03	02006	54LS40	30201
5404	00105	54150	01401	54L04	02005	54LS42	30703†
5405	00108	54151	01406	54L10	02003	54LS47	30704†
5406	00801	54153	01403	54L20	02002	54LS51	30401
5407	00803	54154	15201	54L30	02001	54LS54	30402
5408	01601	54155	15202	54L42	02901	54LS73	30101
5409	01602	54156	15203	54L43	02902	54LS74	30102
5410	00103	54157	01405	54L44	02903	54LS75	31601†
5412	00106	54160	01303	54L46	02904	54LS76	30110
5413	15101	54161	01306	54L47	02905	54LS83A	31201
5414	15102	54162	01305	54L51	04101	54LS85	31101
5416	00802	54163	01304	54L54	04102	54LS86	30502
5417	00804	54164	00903	54L54	04104♦	54LS90	31501†
5420	00102	54165	00904	54L55	04103	54LS92	31511†
5423	00402	54166	00910†	54L71	02101	54LS93	31502†
5425	00403	54173	01703†	54L72	02102	54LS95	30603†
5426	00805	54174	01701	54L73	02103	54LS96	30604†
5427	00404	54175	01702	54L74	02105	54LS107	30108
5428	16201	54177	01312†	54L78	02104	54LS109	30109
5430	00101	54180	01901	54L86	02601	54LS112	30103
5432	16101	54181	01101	54L90	02501	54LS113	30104
5437	00302	54182	01102	54L91	02806♦	54LS114	30105
5438	00303	54186	20101	54L93	02502	54LS122	31403†
5440	00301	54192	01308	54L95	02801	54LS123	31401†
5442	01001	54193	01309	54L121	04201	54LS132	31303
5443	01002	54194	00905	54L122	04202	54LS138	30701†
5444	01003	54195	00906	54L164	02802	54LS139	30702†
5445	01004	54196	01310†	54L164	02802	54LS151	30901†
5446	01006	54197	01311†	54L193	02503	54LS153	30902†
5447	01007	54198	00909†			54LS157	30903†
5448	01008					54LS158	30904†
5449	01009					54LS160	31503†
5450	00501					54LS161	31504†
5451	00502					54LS162	31510†
5453	00503					54LS163	31512†
5454	00504					54LS164	30605†
5470	00206					54LS169	31506†
5472	00201					54LS174	30106
5473	00202					54LS175	30107
5474	00205					54LS181	30801
5475	01501					54LS190	31509†
5476	00204					54LS191	31513†
5477	01502					54LS192	31507†
5480	00604					54LS193	31508†
5482	00601					54LS194	30601†
5483	00602					54LS195	30602†
5485	15001					54LS196	32001†
5486	00701					54LS197	32002†
5490	01307					54LS221	31402†
5492	01301					54LS251	30905†
5493	01302					54LS253	30908†
5495	00901					54LS257	30906†
5496	00902					54LS258	30907†
54107	00203					54LS261	31801†
54116	01503					54LS266	30303
54120	15401†					54LS279	31602†
54121	01201					54LS283	31202†
54122	01202					54LS290	32003†
54123	01203					54LS293	32004†
54125	15301					54LS295	30606†
54126	15302					54LS324	31702†
						54LS395	30607†
						54LS670	31901†

NOTE: Only the basic JAN and commercial numbers are shown.

†Slash sheets not released as of the date of this publication.

‡Not recommended for new designs.

♦Class S only.

10

# MILITARY PRODUCTS

TABLE II. CIRCUIT-TYPE AND JAN INTEGRATED CIRCUITS CROSS-REFERENCE

TTL 54S SERIES		MOS LSI		LINEAR CONTROL SERIES	
CKT TYPE	JAN /NO.	CKT TYPE	JAN /NO.	CKT TYPE	JAN /NO.
54S00	07001	TMS4050	23502 (4K RAM)	LM101A	10103
54S02	07301	TMS4050	23504 (4K RAM)	LM104	10202†
54S03	07002	TMS4060	23501 (4K RAM)	LM105	10203†
54S04	07003	TMS4060	23503 (4K RAM)	LM106	10303
54S05	07004			LM108A	10104
54S08	08003†			LM109	10701
54S09	08004†			LM111	10304
54S10	07005			LM118	10107
54S11	08001			LM140-12	10702†
54S15	08002			LM140-15	10703†
54S20	07006			LM140-21	10704†
54S22	07007			SE555	10901†
54S30	07008			SE556	10902†
54S40	07201			uA710	10301
54S51	07401			uA711	10302
54S64	07402			uA723	10201
54S65	07403			uA733	10501†
54S74	07101			uA741	10101
54S85	08201			uA747	10102
54S86	07501				
54S112	07102				
54S113	07103				
54S114	07104				
54S133	07009				
54S134	07010				
54S135	07502				
54S138	07701†				
54S139	07702†			55107	10401
54S140	08101			55108	10402
54S151	07901			55113	10405
54S153	07902			55114	10403
54S157	07903			55115	10404
54S158	07904				
54S174	07105				
54S175	07106				
54S181	07801				
54S182	07802				
54S194	07601†				
54S195	07602†				
54S251	07905				
54S257	07906				
54S258	07907				
54S280	07703†				

LINEAR INTERFACE SERIES	
CKT TYPE	JAN /NO.
55107	10401
55108	10402
55113	10405
55114	10403
55115	10404

NOTE: Only the basic JAN and commercial numbers are shown.  
 †Slash sheets not released as of date of this publication.

**38510/MACH IV**  
**High-Reliability Microelectronics**  
**Procurement Specifications**  
**MIL-STD-883**

CONTENTS		
SECTION		PAGE
1.0	SCOPE . . . . .	11-4
2.0	APPLICABLE DOCUMENTS . . . . .	11-4
3.0	GENERAL REQUIREMENTS . . . . .	11-6
4.0	QUALITY ASSURANCE PROVISIONS . . . . .	11-16
5.0	PREPARATION FOR DELIVERY . . . . .	11-29
6.0	NOTES . . . . .	11-29

↓

**REVISIONS**

CLASSIFICATION (MAJOR/MINOR)	DATE CODE EFFECTIVITY	LTR	DESCRIPTION	DATE	APPROVED
Major	7040	A	Incorporate MIL-M-38510 and Revision Notice 2 of MIL-STD-883	8/15/70	<i>J.S. Adams</i>
Major	7239	B	Incorporate Revision Notice 3 and 4 of MIL-STD-883 and Revision A of MIL-STD-38510	9/1/72	<i>[Handwritten signatures]</i>
Major	7401	C	Incorporate revised Level IV (SNH) processing with inclusion of recorded electrical data with delta requirements; incorporate technological criteria in Table III for precap of complex circuits.	1/1/74	<i>[Handwritten signatures]</i>
Minor	7518	D	Incorporate Revision A of MIL-STD-883 and provisions for MOS LSI and CMOS devices	4/15/75	<i>[Handwritten signatures]</i>
Minor	7628	E	Incorporate Revision C of MIL-M-38510 and MIL-STD-883 Revision A, Notice 2	6/15/76	<i>[Handwritten signatures]</i>

UNLESS OTHERWISE SPECIFIED DIMENSIONS ARE IN INCHES  
 TOLERANCES:  
 ANGLES : 1°  
 3 PLACE DECIMAL ±.010  
 2 PLACE DECIMAL ±.02

DR *C. C. [Signature]* DATE *7/22/69*  
 CHK *[Signature]* *10/17/69*  
 ENGR *[Signature]* *10/20/69*  
 QUALITY CONTROL *[Signature]* *10/20/69*  
 QRA MGR. *[Signature]* *10/24/69*

INTERPRET DWG. IN ACCORDANCE WITH STD. DESCRIBED IN MIL-STD-100 MATERIAL:

DESIGN ACTIVITY RELEASE DEPARTMENT  
 MANAGER, TTL  
 CIRCUITS DIVISION  
 MANAGER *[Signature]*



**TEXAS INSTRUMENTS**  
INCORPORATED  
SEMICONDUCTOR CIRCUITS DIVISION DALLAS, TEXAS

TITLE **MICROELECTRONICS, HIGH RELIABILITY PROCUREMENT SPECIFICATION (MIL-STD 38510/883)**

SIZE <b>A</b>	CODE IDENT NO. <b>01295</b>	DRAWING NO. <b>38510/MACH IV PROGRAM</b>
SCALE	REV <b>D</b>	SHEET

11

# 38510/MACH IV PROCUREMENT SPECIFICATION

---

## 38510/MACH IV PROGRAM

### 1.0 SCOPE

1.1 This specification establishes standards for materials, workmanship, performance capabilities, identification, and processing of high-reliability monolithic integrated circuits.

### 1.2 Intent

The intent of this document is such as to recognize that quality and reliability are *built* into, not *tested* into, a product. There is no specification or screening procedure that can substitute for inherent, built-in reliability. However, it must be realized that irrespective of lot quality, there will always be some small percentage of devices that are subject to early failure (infant mortality). A well engineered screening procedure will eliminate most, if not all, of these early failures. Secondly, the screening and acceptance testing described herein will also serve to demonstrate, with a high degree of statistical confidence, that the required levels of quality and reliability have, in fact, been built into the product.

### 2.0 APPLICABLE DOCUMENTS

2.1 The following specifications and standards, of the issue in effect on the date of invitation for bids or request for proposal, form a part of this specification to the extent specified herein:

### 2.2 Specifications

#### Military

MIL-M-55565

MIL-M-38510

Microcircuits, Packaging of

Microcircuits devices, general specification for

# 38510/MACH IV PROCUREMENT SPECIFICATION

---

## 2.3 Standards

### Military

MIL-STD-105	Sampling Procedures and Tables for Inspection by Attributes
MIL-STD-883	Test Methods and Procedures for Microelectronics
MIL-STD-790	Reliability Assurance Program for Electronic Parts Specification
MIL-STD-1276	Leads, Weldable, for Electronic Components Parts
MIL-STD-1313	Microelectronics Terms and Definitions

### Detail Specifications

SNXXXX (Bipolar)	Detail Specification for a Particular Part Type (e.g., Manufacturer's Data Sheet)
TMSXXXX (MOS LSI)	
TFXXXX (CMOS)	

## 2.4 Precedence of Documents

For the purpose of interpretation, in case of any conflicts, the following order of precedence shall apply:

- a) Purchase Order —The purchase order shall have precedence over any referenced specification.
- b) Detail Specification —The detail specification shall have precedence over this specification and other referenced specifications.
- c) This Specification —This specification shall have precedence over all referenced specifications.
- d) Referenced Specifications —Referenced Specifications shall apply to the extent specified herein.

2.5 Federal and/or military specifications and standards required shall be obtained from the usual government sources.

# 38510/MACH IV PROCUREMENT SPECIFICATION

---

## 3.0 GENERAL REQUIREMENTS

The individual item requirements shall be as specified herein and in accordance with the applicable detail specification. In the event of any conflict between the requirements of this specification and the detail specification, the latter shall govern. The static and dynamic electrical performance requirements of the integrated circuits plus absolute maximum ratings and test methods shall be as specified in the detail specifications.

### 3.1.1 Definitions

- a) LTPD Lot Tolerance Percent Defective shall be as defined by MIL-M-38510.
- b)  $\lambda$  Lambda, stated in percent per 1000 hours as defined by MIL-M-38510.
- c) MRN Minimum reject number as defined by MIL-M-38510.
- d) Production Lot For the purpose of this specification, a production lot shall be defined per MIL-M-38510.
- e) Inspection Lot An inspection lot shall be as defined in MIL-M-38510.
- f) C Acceptance number as defined by MIL-M-38510.

### 3.1.2 Terms and Definitions

Terms and definitions shall be as defined in MIL-STD-1313.

### 3.1.3 Classification of Requirements

The requirements for the integrated circuits are classified herein as follows:

<u>Requirement</u>	<u>Paragraph</u>
Process Conditioning, Testing and Screening	3.2
Qualification	3.3
Design and Construction	3.4



# 38510/MACH IV PROCUREMENT SPECIFICATION

---

Marking of Integrated Circuits	3.5
Product Assurance	3.6
Workmanship	3.7
Performance Capabilities	3.8
Quality and Reliability Assurance Program Plan	3.9

## 3.2 Process Conditioning, Testing and Screening

Three levels of screening and quality assurance for integrated circuits are provided for in this specification. Process conditioning, testing and screening shall be as specified in 4.3 and the applicable figure for the appropriate quality assurance level stated on the purchase order and defined as follows:

SCREENING LEVEL	PART NUMBER PREFIX			APPLICABLE FLOW CHART
	BIPOLAR	CMOS	MOS LSI	
38510/883 Class A (Level IV)	SNH	Not Avail.	Not Avail.	Figure 4
38510/883 Class B (Level III)	SNC	TFC		Figure 3
			SMC	Figure 2
38510/883 Class C (Level I)	SNM	TFM	Not Avail.	Figure 1

## 3.3 Qualification

Vendor qualification for delivery of integrated circuits to this specification shall be as specified in paragraph 4.2.

## 3.4 Design and Construction

Integrated circuit design and construction shall be in accordance with the requirements specified herein and in the applicable detail specification.

### 3.4.1 Topography

Integrated circuits furnished under this specification shall have topography information available for review by procuring activity. The information made available shall provide sufficient data for thorough circuit design, application, performance, and failure analysis studies.

#### 3.4.1.1 Monolithic Die Topography

An enlarged photograph or drawing (to scale) with a minimum magnification of 80 times the die (chip) size showing the topography of elements formed on the silicon monolithic die shall be available for review. This shall be identified with the specific detail integrated circuit part-type in which it is used and the applicable detail specification.

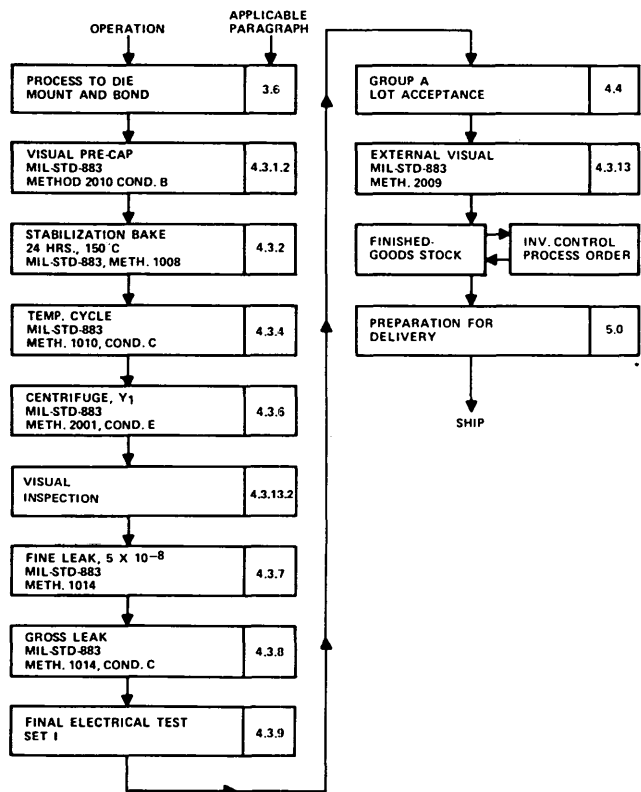

FIGURE 1—FLOW CHART FOR 38510 CLASS C LEVEL I

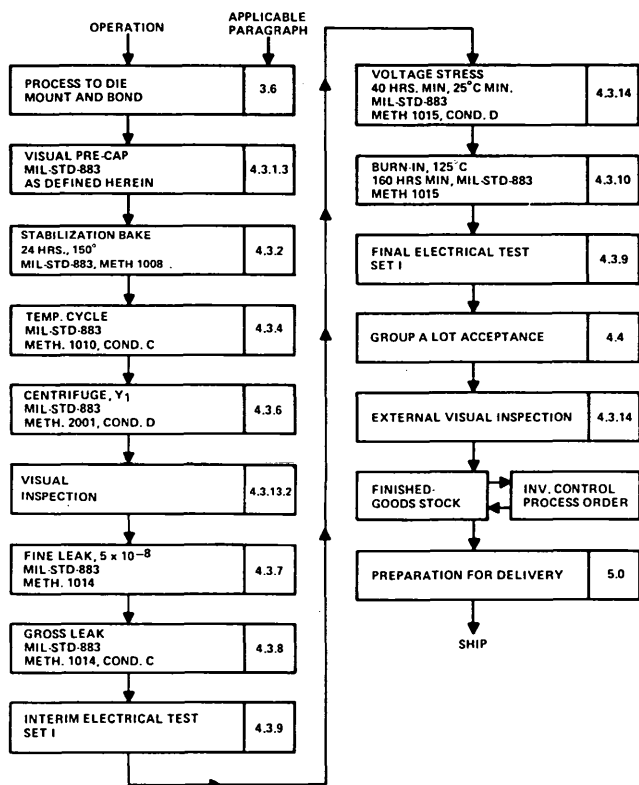

FIGURE 2—FLOW CHART FOR MOS LSI  
38510 CLASS B (LEVEL III SMC)

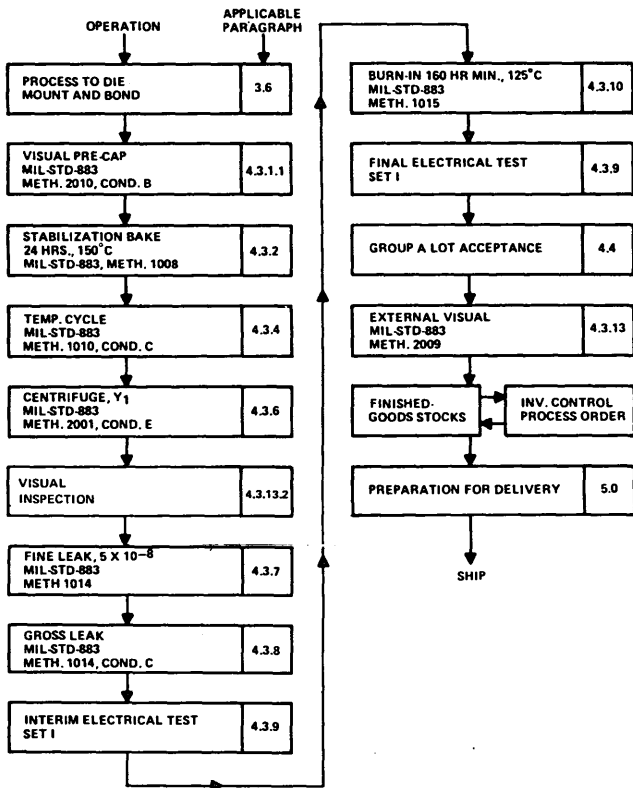

FIGURE 3—FLOW CHART FOR 38510 CLASS B LEVEL III

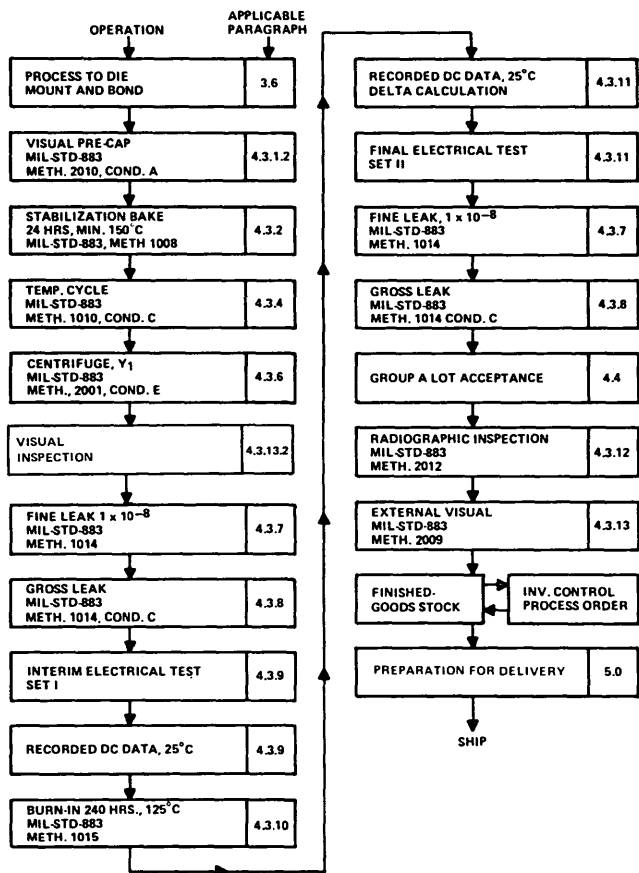

FIGURE 4—FLOW CHART FOR 38510 CLASS A LEVEL IV

# 38510/MACH IV PROCUREMENT SPECIFICATION

---

## 3.4.1.2 Die Intraconnection Pattern

An enlarged photograph or drawing (to scale) with a minimum magnification of 80 times the die (chip) size showing the specific intraconnection pattern utilized to intraconnect the elements in the circuit. This shall be in the same scale as the die topography 3.4.1.1 so that the elements utilized and those not being used can easily be determined.

## 3.4.2 Materials

Materials shall be inherently non-nutrient to fungus and shall not blister, crack, outgas, soften, flow or exhibit other immediate or latent defects that adversely affect storage, operation or environmental capabilities of integrated circuits.

### 3.4.2.1 Material Selection

Materials selected for use in the construction of the integrated circuits shall be chosen for maximum suitability for the application. This shall include consideration of the best balance for:

- a) Electrical performance
- b) Thermal compatibility and conductivity
- c) Chemical stability including resistance to deleterious interactions with other materials
- d) Metallurgical stability with respect to adjacent materials and change in crystal configuration
- e) Maximum stability with regard to continued uniform performance through the specified environmental conditions and life.

### 3.4.2.2 Foreign Materials

No lacquer, grease, paste, desiccant or other similar foreign encapsulant or coating material shall be included in the circuit enclosure nor applied to any part of the internal circuit assembly.

## 3.4.3 Mechanical

### 3.4.3.1 Case

Each integrated circuit shall be securely mounted and hermetically sealed within a case designed and constructed to conform to the outline and physical dimensions shown in the detailed specification.

# 38510/MACH IV PROCUREMENT SPECIFICATION

---

## 3.4.3.2 Interconnections

Interconnections within the integrated circuit case shall be minimized and there shall be no wire crossovers. Circuit intraconnections by means of wire jumpers shall not be used. (See Note 6.2)

## 3.4.3.3 Leads

Lead material, construction, and outline shall be as specified on the detail specification and shall be capable of meeting the solderability test of MIL-STD-883, Method 2003. (See note 6.4).

### 3.4.3.3.1 Lead Size

Lead outline and dimensions shall be as specified in the detail specification.

### 3.4.3.3.2 Lead Surface Condition

Leads shall be free of the following defects over their entire length when inspected under a minimum of 4X magnification:

- a) Foreign materials adhering to the leads such as paint, film, deposits and dust. Where adherence of such foreign materials is in question, leads may be subjected to a clean, contaminant-free (e.g., oil, dust, etc.), filtered air stream (suction or expulsion) of 88 feet per second maximum, or a wash/rinse as necessary and reinspected.
- b) Nicks, cuts, scratches or other surface defacing defects which expose the base metal.

### 3.4.3.3.3 Lead Straightness

Leads shall be aligned within a 0.050-inch diameter, 0.050-inch length cylinder concentric to the point of lead emergence from the case and the X-axis (the axis parallel to the lead axis). Along the remaining lead length, there shall be no unspecified bend whose radius is less than 0.10 inch and no twist whose angle is greater than 30° (ribbon leads, only).

### 3.4.3.3.4 Preformed Leads

Preformed leads, when specified, shall be in accordance with the detail specification. The part number of the integrated circuit shall remain as specified in the applicable detail specification or purchase order, the applicable suffix designation shall appear on the purchase order but shall not be marked on the device.

# 38510/MACH IV PROCUREMENT SPECIFICATION

---

## 3.4.3.3.5 Carriers (Mech-Pak Carrier)

Carrier-matrix assemblies consisting of individually mounted integrated circuits shall be furnished when so specified by purchase order. The individual carriers shall have provisions for use with automatic test equipment contacts. Devices supplied "clipped-out" of the Mech-Pak Carrier shall be supplied in the Barnes Carrier type 029-188 or equivalent. (Applicable to Flat Packs only.)

## 3.5 Marking of Integrated Circuits

### 3.5.1 Legibility

All marking shall be permanent in nature and remain legible when subjected to specified operating, storage, and environmental requirements. All markings shall be insoluble in standard solvents such as trichlorethylene, water and xylene.

### 3.5.2 Marking Details

Marking of the integrated circuits shall be located as follows unless otherwise specified in the detail specification:

- a) TO-99, TO-100, and similar "can" cases shall be marked on the top of the case. Where space limitations exist, the side of the case may be used.
- b) Flat Packs shall be marked on the top of the case. Where space limitation exists, the bottom of the package may be utilized as necessary. As a minimum the top of the package shall show the manufacturer's identification mark or symbol, the device part number, date code, and pin 1 orientation mark (where applicable).
- c) Dual-in-line plug-in packages shall be marked in the same manner as flat packs.

### 3.5.3 Required Device Marking

- a) Index point indicating the starting point for numbering of leads shall be as indicated in the detail specification. The indexing point may be a tab, color dot, or other suitable indicator.
- b) Manufacturer's identification mark or symbol.
- c) A lot date code indicating the week of initial submission for screening or inspection. The date code shall be as follows:
  - 1) EIA four-digit date code, the first two numbers shall be the last two digits of the year, the last two numbers shall indicate the calendar week.

## 38510/MACH IV PROCUREMENT SPECIFICATION

---

- 2) EIA three-digit date code (when limited by space available), the first number shall be the last digit of the year, the last two numbers shall indicate the calendar week.
  
  - d) Manufacturer's part number defining circuit type and applicable MIL-STD-883 screening level and MIL-M-38510 product assurance level as defined in paragraph 3.2.
  - e) Individual device serial number is required for Class A (SNH).
  - f) A dot to indicate acceptance by Radiographic inspection.
- NOTE:
- When a color dot is used to identify pin one, the radiographic inspection acceptance dot shall be placed on the bottom of the package.
- g) Country of origin shall be per U.S. Customs codes.

### 3.6 Product Assurance

The manufacturer shall establish and maintain a reliability assurance program that complies with the basic intent of MIL-STD-790. Furthermore, it is intended that each integrated circuit delivered shall be free of any defect in design, material, manufacturing process, testing and handling, which would degrade or otherwise limit its performance when used within the specified limits.

#### 3.6.1 Visual and Mechanical Examination

Integrated circuits shall be examined to verify that material, design, construction, physical dimensions, marking and workmanship are in accordance with the specified acceptance criteria.

#### 3.6.2 Test Equipment

The manufacturer shall prepare and maintain a current list, by name and drawing number or other unique identification, of test equipment used in the manufacturing and testing of devices submitted for acceptance inspection under this specification. This list shall be made available to the procuring activity representative upon request.

#### 3.6.3 Process Controls

Each integrated circuit shall be constructed by manufacturing processes which are under the surveillance of the manufacturer's Quality Control department. The processes shall be monitored and controlled by use of statistical techniques in accordance with published specifications and procedures. The manufacturer shall prepare and maintain suitable documentation (such as quality control manuals, inspection instructions, control charts, etc.) covering all phases of incoming part and material inspection and in-process inspections required to assure that product quality meets the requirements of this specification. The

11

## 38510/MACH IV PROCUREMENT SPECIFICATION

---

procuring activity may verify, with the permission of and in the company of the manufacturer's designated representative, that suitable documentation exists and is being applied. Information designated as proprietary by the manufacturer will be made available to the procuring activity or its representative only with the written permission of the manufacturer.

Process control is recognized as being vital to the concept of "built-in" quality. The process control program shall include a scanning electron microscope (SEM) monitor program for evaluating the metal integrity over oxide step and oxide step contour. The SEM analysis will be defined in a Quality & Reliability Assurance document.

### 3.6.4 Production Changes

The manufacturer shall advise the procuring activity of the time at which any major change(s) in production or QC methods or documentation become effective during the period of device production for delivery against any given purchase order referencing this specification.

### 3.7 Workmanship

Integrated circuits shall be manufactured and processed in a careful and workmanlike manner, in accordance with the production processes, workmanship instructions, inspection and test procedures, and training aids prepared by the manufacturer in fulfillment of the reliability assurance program established by paragraph 3.6.

#### 3.7.1 Personnel Certification

The manufacturer shall be responsible for training, testing and certification of personnel involved in producing integrated circuits. Training shall be commensurate and consistent with the requirements of this specification and in conformance to the basic intent of MIL-STD-790. Training aids in the form of satisfactory criteria shall be available for operator and inspector review at any time.

#### 3.7.2 Personnel Evaluation

The supplier shall maintain a continuous evaluation of the proficiency of personnel concerned with production and inspection. Retraining of an operator or inspector shall be required when this evaluation establishes that a degree of proficiency necessary to meet the requirements of this specification is not being exercised.



## 38510/MACH IV PROCUREMENT SPECIFICATION

---

### 3.7.3 Rework provisions

#### 3.7.3.1 Rework

All rework on microrcircuits manufactured under this specification shall be accomplished in accordance with paragraph 3.7.1 of MIL-M-38510 as defined herein.

#### 3.7.3.2 Rebonding

Rebonding shall be in accordance with MIL-M-38510, as defined herein (see Note 6.5)

### 3.8 Performance Capabilities

The integrated circuits delivered to this specification shall be designed to be capable of meeting the environmental requirements specified in Table II. The manufacturer need not perform these tests specifically for the contract or specification, but shall provide data which demonstrates the ability of the integrated circuits to pass the environmental tests. The data shall have been generated on devices from the same generic family as the circuits being supplied to this specification, and the package configuration shall be the same as for the delivered parts (i.e., Flat Pack, TO-100, etc.).

### 3.9 Quality and Reliability Assurance Program Plan

The manufacturer shall establish and implement a Quality and Reliability Assurance Program Plan that meets the intent of MIL-M-38510, Appendix A. Submission of the program plan to the procuring activity shall not be a requirement of this specification; however, the program plan shall be maintained by the manufacturer and shall be available for review by the procuring activity.

# 38510/MACH IV PROCUREMENT SPECIFICATION

---

## 4.0 QUALITY ASSURANCE PROVISIONS

### 4.1 Responsibility for Inspection

Unless otherwise specified in the contract or purchase order, the manufacturer is responsible for the performance of all inspection requirements specified herein. Except as otherwise specified, the manufacturer may utilize his own facilities or any commercial laboratory acceptable to the procuring activity. The procuring activity may, at its discretion, perform any of the inspections set forth in the specification where such inspections are deemed necessary to assure supplies and services conform to prescribed requirements.

#### 4.1.1 Inspection and Testing Procedures Coverage

Inspection and testing processes and procedures prepared in fulfillment of the reliability assurance program established per paragraph 3.6 shall be prescribed by clear, complete and current instructions. These instructions shall assure inspection and test of materials, work in process and completed integrated circuits as required by this specification. In addition, criteria for approval and rejection of materials and integrated circuits shall be included.

#### 4.1.2 Inspection at Point of Delivery

The procuring activity may, at its discretion, reinspect any or all of the delivered parts excluding Groups B, C, and D destructive samples as defined by MIL-STD-883. All parts found to be defective, excluding devices exhibiting damage from use, may be returned to the manufacturer at the manufacturer's expense.

#### 4.1.3 Inspection Records

The manufacturer shall maintain a reliability data and records library. This library shall have on file, for review by the procuring activity, records of examination, qualification test results, variables data (when required) and all other pertinent data generated on devices manufactured to this specification.

#### 4.1.4 Control of Procurement Sources

The manufacturer shall be responsible for assuring that all supplies and services conform to this specification, the detail specification and the manufacturer's procurement requirements.

## 38510/MACH IV PROCUREMENT SPECIFICATION

---

### 4.1.4.1 Manufacturer's Receiving Inspection

Purchased supplies shall be subjected to inspection after receipt as necessary to ensure conformance to contract requirements. In selecting sampling plans, consideration shall be given to the controls exercised by the procurement source and evidence of sustained quality conformance.

4.1.4.2 The manufacturer shall provide procedures for withholding from use all incoming supplies pending completion of required tests or receipt of necessary certification or test records and their evaluation.

4.1.4.3 The manufacturer shall initiate corrective action with the procurement source depending upon the nature and frequency of receipt of nonconforming supplies.

### 4.1.5 Procuring Activity Quality Assurance Representative

The procuring activity, may, at its discretion, place quality assurance representatives in the manufacturer's plant as deemed necessary to assure conformance to contract requirements in any non-proprietary phase of design, fabrication, processing, inspection, and testing of the integrated circuits being produced. The manufacturer shall provide reasonable facilities and assistance for the safety and convenience of such personnel in the performance of their duties. Inspection and test procedures shall be made available for review by the quality assurance representative.

## 4.2 Qualification and Quality Conformance Inspection

### 4.2.1 Qualification

When specifically called out and funded on the purchase order or contract, the manufacturer's specific device qualification shall be based on compliance with the quality conformance test per Table III for MOS LSI devices. Qualification for other technologies shall be per Table I except that the testing will be to one LTPD level tighter than as defined in Table B-1 of MIL-M-38510. For 38510 Class A (Level IV), qualification shall be per MIL-STD-883, Method 5005, Table IIa.

### 4.2.1.2 Procedures and Definitions

#### 4.2.1.2.1 Sampling Procedure

Device selection for the qualification procedure of 4.2.1 shall be based on a random sampling technique and will be selected from a generic family.

# 38510/MACH IV PROCUREMENT SPECIFICATION

---

## 4.2.1.2.2 Generic Family

Electrically and structurally similar devices shall be said to comprise a generic family (e.g., TTL) if they meet the following criteria:

- a) Are designed with the same basic circuit-element configuration such as TTL, TTL Schottky, DTL, CMOS, MOS metal-gate, or MOS silicon-gate, and differ only in the number or complexity of specified circuits that they contain. Generic family for linear circuits is defined by circuit function (e.g., op amp, comparator, etc.).
- b) Are designed for the same supply, bias and signal voltage, and for input/output capability with each other under an established set of loading rules.
- c) Are enclosed in housings (packages) of the same basic construction (e.g., hermetically sealed flat packages, dual-in-line ceramic, dual-in-line plastic) and outline, differing only in the number of active housing terminals included and/or utilized.

## 4.2.2 Quality Conformance Inspection

Quality conformance inspections (Groups B, C, and D) are per Tables I and II. Table II shall apply to MOS LSI and Table I to other technologies.

- a) When specifically called out and funded on the purchase order or contract, the manufacturer shall perform the quality conformance inspections (Groups B, C, and D) on a lot-by-lot basis.
- b) The manufacturer shall, upon request, make available for review the following generic quality conformance inspection and data:

Group B — To be performed every six weeks on each package type (a different number of pins constitutes a different package) at each assembly location.

Group C — To be performed every three months on each generic family as defined in 4.2.1.2.2a and b.

Group D — To be performed every six months on each package type (a different number of pins constitutes a different package) at each assembly location.

### 4.2.2.1 Lot Acceptance Sampling

Statistical sampling for quality conformance inspections shall be in accordance with MIL-M-38510 Table B-I.

Group B samples shall be selected from sublots that have successfully completed all of the 100% processing steps specified on the applicable process flow chart.

# 38510/MACH IV PROCUREMENT SPECIFICATION

---

## 4.2.2.2 Resubmission of Failed Lots

When any lot (paragraph 4.2.2.a) submitted for quality conformance inspection fails any subgroup requirement, it may be resubmitted a maximum of one time for that particular subgroup. This additional submission is permitted, provided an analysis is performed to determine the failure mechanism for each reject device in the subgroup, and that it is determined that the failures are due to one of the following:

- a) Testing error resulting in electrical damage to devices
- b) A defect that can effectively be removed by rescreening the lot
- c) Random defects that do not reflect poor basic device designs or poor workmanship.

## 4.2.2.3 Early Shipments

When quality conformance inspection is being performed for a specific contract or purchase order, the accepted Group A devices that are awaiting shipment pending successful completion of Groups B, C, and D shall be stored and controlled by Quality Assurance. Under no circumstances shall such parts be shipped prior to the successful completion of the Group B tests.

## 4.2.2.4 Groups B, C, and D Test Data

All lot-by-lot data generated by Groups B, C, and D testing when specifically called out and funded on the purchase order, shall accompany the initial shipment of devices. This data shall consist, at a minimum, of the following:

- a) Attributes data for Group B. Endpoints for the subgroups are visual per the applicable MIL-STD-883 test method.
- b) Attributes data for Groups C and D. Endpoints for each subgroup are electrical test parameters as defined in Tables I and II.

## 4.2.2.5 Procedure in Case of Test Equipment Failure or Operator Error

Where an integrated circuit is believed to have failed as a result of faulty test equipment or operator error, the failure shall be entered in the test record which shall be retained for review along with a complete explanation verifying why the failure is believed to be invalid. If it is determined that the failure is invalid, a replacement integrated circuit from the same inspection lot may be added to the sample. The replacement integrated circuit shall be subjected to all those tests to which the discarded integrated circuit was submitted prior to its failure, and any remaining specified test to which the discarded integrated circuit was not subjected prior to its failure.

## 4.3 Quality Assurance Processing, Methods and Procedures

This section establishes the test methods and conditions to be used for the 100% processing (screening) requirements specified by the applicable process flow chart.

### 4.3.1 Precap Visual Inspection

Each microcircuit shall be required to pass the appropriate precap visual inspection defined as follows. Precap Lot Acceptance shall be per paragraph 4.6.

---

## 38510/MACH IV PROCUREMENT SPECIFICATION

---

- 4.3.1.1 38510 Class C (Level I) and 38510 Class B (Level III) devices shall be visually inspected in accordance with MIL-STD-883, Method 2010, Condition B.
- 4.3.1.2 38510A Class A (Level IV) devices (designated for NASA type applications) shall be visually inspected in accordance with MIL-STD-883, Method 2010, Condition A. (See notes 6.1.1.1 and 6.1.1.2.) (See notes under 6.1.2 for MOS LSI devices.)
- 4.3.1.3 Complex MSI and LSI circuits as defined in MIL-STD-883, Method 5004, paragraph 3.3 may be precap inspected per MIL-STD-883, Method 5004, paragraph 3.3.1 for 38510 Class B (Level III) and paragraph 3.3.2 for 38510 Class C (Level I).

### 4.3.2 Stabilization Bake

The purpose of this test is to determine the effect on microelectronic devices of baking at elevated temperatures without electrical stress applied. Test shall be performed in accordance with MIL-STD-883, Method 1008, Condition C.

### 4.3.3 Thermal Shock

The purpose of this test is to determine the resistance of the device to sudden exposure to extreme changes in temperature. Test shall be performed in accordance with MIL-STD-883, Method 1011, Condition A.

### 4.3.4 Temperature Cycle

This test is conducted for the purpose of determining the resistance of a part to exposures to extremes of high and low temperatures, and to the effect of alternate exposures to these extremes, such as would be experienced when equipment or parts are transferred to and from heated shelters in arctic areas. Test shall be performed in accordance with MIL-STD-883, Method 1010, Condition C, for a minimum of 10 cycles. For MSI and LSI complex devices as defined in MIL-STD-883, Method 5004, paragraph 3.3, 50 cycles may be used in lieu of alternate pre-cap visual inspection criteria.

### 4.3.5 (Deleted)

### 4.3.6 Centrifuge (Constant Acceleration)

The centrifuge test is used to determine the effects on microelectronics devices of a centrifugal force. This test is designed to indicate structural and mechanical weaknesses not necessarily detected in shock and vibration tests. Test shall be performed in accordance with MIL-STD-883, Method 2002, Condition E for devices having 20 or less pins and Condition D for those having more than 20 pins.

## 38510/MACH IV PROCUREMENT SPECIFICATION

---

### 4.3.7 Fine Leak Test

Each integrated circuit for 38510 Class C (Level I), 38510 Class B (Level III), and 38510 Class A (Level IV) screens shall be subject to a fine leak test in accordance with paragraph 4.3.7.1 or 4.3.7.2. The method shall be optional providing it is consistent with and capable of detecting the specified leak rate of the applicable process flow chart.

#### 4.3.7.1 Helium Leak Test

Helium leak test shall be performed in accordance with MIL-STD-883, Method 1014, Condition A.

#### 4.3.7.2 Radiflo Leak Test

Radiflo leak test shall be performed in accordance with MIL-STD-883, Method 1014, Condition B. Krypton 85 bomb pressure and dwell time are a function of the radioactivity level and shall be selected so as to conform to the equations given in Condition B.

### 4.3.8 Gross-Leak Test

Each integrated circuit for 38510 Class C (Level I), 38510 Class B, (Level III) and 38510 Class A (Level IV) screens shall be subjected to the appropriate gross-leak test of paragraph 4.3.8.1 or 4.3.8.2, or an approved equivalent. The manufacturer may, at his option, perform gross-leak testing after the Set I Electrical Tests of paragraph 4.3.9.

4.3.8.1 When specifically called out and funded on the purchase order or contract, units will be bombed 2 hours minimum at 30 psig in FC-78, or equivalent. Units will then be immersed in FC-40 or equivalent at  $+125^{\circ}\text{C} \pm 5^{\circ}\text{C}$  for 30 seconds minimum and observed for for a definite stream of bubbles, more than two large bubbles, or an attached bubble that grows in size, per MIL-STD-883, Method 1014, Condition C2.

4.3.8.2 Units will be immersed in FC-40 or equivalent at  $+125^{\circ}\text{C} \pm 5^{\circ}\text{C}$  for 30 seconds minimum and observed for a definite stream of bubbles, or more than two large bubbles per MIL-STD-883, Method 1014, Condition C1.

### 4.3.9 Final Electrical Test (Set I)

Each integrated circuit shall be required to pass the electrical requirements of the data sheet. The manufacturer shall also perform such additional testing necessary to assure the parts will meet the temperature extreme limits. MOS LSI memory devices will be 100% tested both at  $25^{\circ}\text{C}$  and at high temperature. Linear circuits will be 100% dc tested at high and low temperatures and  $25^{\circ}\text{C}$ .

When specifically called out and funded on the purchase order or contract, the manufacturer shall perform subgroups 2, 3, and 4 of paragraph 4.4 in accordance with Method 5004 of MIL-STD-883.

# 38510/MACH IV PROCUREMENT SPECIFICATION

---

## 4.3.10 Burn-In

The burn-in screen is performed for the purpose of eliminating marginal devices and early-life failures. Device biasing shall be in accordance with MIL-STD-883 Method 1015, Conditions A, D, or E for Digital Circuits and Conditions B, C, or D for Linear Circuits. For 38510 Class B (Level III) devices, equivalent test conditions using the time/temperature acceleration factor of Condition F between the temperature range of 125°C to 150°C may be used. For 38510 Class B (Level III) MSI and LSI complex devices as defined in MIL-STD-883 paragraph 3.3.1, a 240 hour burn-in in lieu of alternate pre-cap visual inspection criteria per MIL-STD-883, Method 5004, paragraph 3.3.1 may be used.

## 4.3.11 Final Electrical Test (Set II)

Each 38510 Class A (Level IV) integrated circuit shall be required to pass the electrical requirements of the detail specifications. The following tests shall be performed as a minimum: dc parameters at maximum and minimum rated temperatures, and switching parameters at 25°C. In addition, each bipolar device shall have critical 25°C dc electrical parameters read and recorded by serial number and shall pass the following delta requirements:

<u>PARAMETER</u>	<u>DELTA LIMIT</u>
VOL	±10% of detail specification limit
VOH	±10% of detail specification limit
I <sub>IL</sub>	±10% of detail specification limit
I <sub>IH</sub>	±10% of detail specification limit

CMOS recorded parameters and delta limits will be defined by the manufacturer as required.

One copy of the pre-burn-in and post-burn-in recorded data with delta calculations shall be shipped with each lot. Data will not be available for the metal flat pack (T). See MIL-M-0038510, Class S. The manufacturer may, when deemed necessary, elect to perform additional electrical testing over and above the requirements stated herein.

## 4.3.12 Radiographic Inspection (X-Ray)

Test shall be performed in accordance with MIL-STD-883, Method 2012. X-ray may be performed at any point after serialization at the manufacturer's option (see note 6.3).

## 4.3.13 External Visual Inspection

4.3.13.1 The purpose of this examination is to verify that materials, construction, marking, and general workmanship are as specified. Examination shall be in accordance with MIL-STD-883, Method 2009.



# 38510/MACH IV PROCUREMENT SPECIFICATION

4.3.13.2 Visual inspection will be performed for catastrophic failures. Catastrophic failures are defined as missing leads, broken packages, and damaged lids.

## 4.3.14 Voltage Stress

Selected n-channel MOS LSI devices will be voltage stressed for 40 hours minimum at 25°C min per MIL-STD-883 Method 1015, Condition D.

## 4.4 Group A Conformance

Group A conformance shall consist of the electrical parameters in the manufacturer's data sheet. If an inspection lot is made up of a collection of sublots, each subplot shall conform to Group A, as specified.

SUBGROUP	LTPD (%)			
	LEVEL I 38510C	LEVEL II	LEVEL III 38510B	LEVEL IV 38510A
Subgroup 1 25°C, dc	5	7	5	5
Subgroup 2 High Temperature, dc	10	10	7	5
Subgroup 3 Low Temperature, dc	10	10	7	5
Subgroup 4 Dynamic and Switching Tests @ 25°C	10	10	7	5

NOTES: Functional tests included in dc tests.  
MOS LSI devices will be lot accepted at 25°C and high temperature.  
The LTPD's of subgroups 1 and 2 will apply.

## 4.5 Certification

The manufacturer shall include a certificate of compliance with each shipment of parts if requested on the purchase order. This certificate shall indicate that all specified tests and requirements of this specification have been made or met, and that the lot of devices (identified by lot and/or batch number) is acceptable. The certificate shall bear the name and signature of the manufacturer's Quality Control representative, the date of acceptance or signing, and any pertinent notes as applicable.

## 4.6 Precap Lot Acceptance

After each precap inspection the lot of devices shall be sampled by quality control and inspected for the specified visual criteria.

# 38510/MACH IV PROCUREMENT SPECIFICATION

TABLE 1  
QUALITY CONFORMANCE TEST (GROUPS B, C, D)

TEST	MIL-STD-883		CLASSES B, C LTPD
	METHOD	CONDITION	
<b>GROUP B 1/</b>			
<b>Subgroup 1</b> Physical dimensions	2016		2 devices (no failures)
<b>Subgroup 2</b> a. Resistance to solvents	2015	Failure criteria from design and construction requirements of applicable procurement document.  (1) Test condition D (2) Test condition D	3 devices (no failures) 1 device (no failures) 15
b. Internal visual and mechanical	2014		
c. Bond strength <sup>2/</sup> (1) Thermocompression (2) Ultrasonic or wedge	2011		
<b>Subgroup 3</b> Solderability <sup>3/</sup>	2003	Soldering temperature of $260 \pm 10^{\circ}\text{C}$ .	15

- Electrical reject devices from the same inspection lot may be used for all subgroups when end-point measurements are not required.
- Test samples for bond strength may, at the manufacturer's option unless otherwise specified, be randomly selected following internal visual (precap) inspection specified in method 5004, prior to sealing.
- All devices submitted for solderability test must have been through the temperature/time exposure specified for burn-in. The LTPD for solderability test applies to the number of leads inspected except in no case shall less than 3 devices be used to provide the number of leads required.

**GROUP C (Die Related Tests)**

<b>Subgroup 1</b> Operating life test End point electrical parameters	1005	Test condition to be specified (1000 hours) As specified in the applicable device specification	5
<b>Subgroup 2</b> Temperature cycling Constant acceleration Seal (a) Fine (b) Gross <sup>2/</sup> Visual examination End-point electrical parameters	1010 2001 1014   1/	Test condition C Test condition E min. (see 3) Y <sub>1</sub> axis followed by one other axis X or Z. As applicable  As specified in the applicable device specification	15

- Visual examination shall be in accordance with method 1010.
- When fluorocarbon gross-leak testing is utilized, test condition C<sub>2</sub> shall apply as minimum.

# 38510/MACH IV PROCUREMENT SPECIFICATION

**TABLE 1**  
**QUALITY CONFORMANCE TEST (GROUPS B, C, D)**  
(continued)

TEST	MIL-STD-883		CLASSES B, C LTPD
	METHOD	CONDITION	

**GROUP D (Package Related Test)**

<b>Subgroup 1</b> Physical dimensions	2016		15
<b>Subgroup 2</b> <sup>1/</sup> Lead integrity Seal (a) Fine <sup>2/</sup> (b) Gross <sup>3/</sup>	2004 1014	Test condition B2 (lead fatigue) As applicable	15
<b>Subgroup 3</b> <sup>4/</sup> Thermal shock Temperature cycling Moisture resistance Seal (a) Fine <sup>2/</sup> (b) Gross <sup>3/</sup> Visual examination End point electrical parameters	1011 1010 1004 1014  5/  	Test condition B as a minimum, 15 cycles minimum. Test condition C, 100 cycles minimum.  As applicable  As specified in the applicable device specification.	15
<b>Subgroup 4</b> <sup>4/</sup> Mechanical shock Vibration variable frequency Constant acceleration Seal (a) Fine <sup>2/</sup> (b) Gross <sup>3/</sup> Visual examination End point electrical parameters	2002 2007 2001 1014  6/ 5005	Test condition B Test condition A Test condition E (see 3) As applicable  Subgroups 1, 2, 3, and 7.	15
<b>Subgroup 5</b> <sup>1/</sup> Salt atmosphere Visual examination	1009 <sup>7/</sup>	Test condition A. Omit initial conditioning	15

1. Electrical reject devices from the same production lot may be used for samples.
2. Condition A or B per paragraph 3.7 herein.
3. When fluorocarbon gross leak testing is utilized; test condition C2 shall apply as minimum.
4. Devices used in subgroup 3, "Thermal and Moisture Resistance", may be used in subgroup 4, "Mechanical".
5. Visual examination shall be in accordance with method 1010 or 1011 at a magnification of 5X to 10X.
6. Visual examination shall be performed in accordance with method 2007 for evidence of defects or damage to case, leads, or seals resulting from testing (not fixturing). Such damages shall constitute a failure.
7. Visual examination shall be in accordance with paragraph 3.3,1 of method 1009.

# 38510/MACH IV PROCUREMENT SPECIFICATION

---

TABLE II  
QUALITY CONFORMANCE TEST  
MOS LSI CIRCUIT

TEST	MIL-STD-883 METHOD	CONDITIONS	LTPD
Subgroup 1			
Temperature Cycle	1010	Condition C	
Constant Acceleration	2001	Condition D <sup>1</sup> , Y <sub>1</sub> Plane	
Electrical End Points	5005	Subgroup 1	15
Subgroup 2			
Operating Life	1005	Condition D, 500 Hrs. Minimum	
Electrical End Points	5005	Subgroup 1	10

1. Condition D for packages with more than 20 pins. Condition E for packages with 20 pins or less.

# 38510/MACH IV PROCUREMENT SPECIFICATION

**TABLE III  
MANUFACTURER'S QUALIFICATION PROCEDURE  
MOS LSI CIRCUITS**

TEST	MIL-STD-883		CLASSES B, C LTPD
	METHOD	CONDITION	

**GROUP B**

<b>Subgroup 1</b> Physical dimensions	2016		2 devices (no failures)
<b>Subgroup 2</b> a. Resistance to solvents	2015	Failure criteria from design and construction requirements of applicable procurement document.  (1) Test condition D (2) Test condition D	3 devices (no failures)  1 device (no failures)  15
b. Internal visual and mechanical	2014		
c. Bond strength <sup>2/</sup> (1) Thermocompression (2) Ultrasonic or wedge	2011		
<b>Subgroup 3</b> Solderability <sup>3/</sup>	2003	Soldering temperature of 260 ± 10° C.	15

1. Electrical reject devices from the same inspection lot may be used for all subgroups when end-point measurements are not required.
2. Test samples for bond strength may, at the manufacturer's option unless otherwise specified, be randomly selected following internal visual (precap) inspection specified in method 5004, prior to sealing.
3. All devices submitted for solderability test must have been through the temperature/time exposure specified for burn-in. The LTPD for solderability test applies to the number of leads inspected except in no case shall less than 3 devices be used to provide the number of leads required.

**GROUP C (Die Related Tests)**

<b>Subgroup 1</b> Operating life test End point electrical parameters Subgroups 1, 2, 3, and 7	1005 5005	T <sub>A</sub> = 85° C, 1000 hours minimum	5
<b>Subgroup 2</b> Temperature cycling Constant acceleration	1010 2001	Test condition C Test condition E for package with < 20 pins Test condition D for packages with ≥ 20 pins Y <sub>1</sub> axis followed by one other axis X or Z.	15
Seal (a) Fine (b) Gross <sup>2/</sup>	1014		
Visual examination End-point electrical parameters	1/	As specified in the applicable device specification	

1. Visual examination shall be in accordance with method 1010.
2. When fluorocarbon gross-leak testing is utilized, test condition C<sub>2</sub> shall apply as minimum.

# 38510/MACH IV PROCUREMENT SPECIFICATION

TABLE III  
 MANUFACTURER'S QUALIFICATION PROCEDURE  
 MOS LSI CIRCUITS  
 (continued)

TEST	MIL-STD-883		CLASSES B, C LTPD
	METHOD	CONDITION	
<b>GROUP D (Package Related Test)</b>			
<b>Subgroup 1</b> Physical dimensions	2016		15
<b>Subgroup 2<sup>1/</sup></b> Lead integrity Seal (a) Fine <sup>2/</sup> (b) Gross <sup>3/</sup>	2004 1014	Test condition B2 (lead fatigue) As applicable	15
<b>Subgroup 3<sup>4/</sup></b> Thermal shock Temperature cycling Moisture resistance Seal (a) Fine <sup>2/</sup> (b) Gross <sup>3/</sup> Visual examination End point electrical parameters	1011 1010 1004 1014  <u>2/ 5/</u>	Test condition B as a minimum, 15 cycles minimum Test condition C, 100 cycles minimum.  As applicable  As specified in the applicable device specifications.	15
<b>Subgroup 4<sup>4/</sup></b> Mechanical shock Vibration variable frequency Constant acceleration Seal (a) Fine <sup>2/</sup> (b) Gross <sup>3/</sup> Visual examination End point electrical parameters	2002 2007 2001 1014  <u>3/ 6/</u> 5005	Test condition B Test condition A Test condition E (see 3) As applicable  Subgroups 1, 2, 3, and 7.	15
<b>Subgroup 5<sup>1/</sup></b> Salt atmosphere Visual examination	1009 <u>5/ 7/</u>	Test condition A. Omit initial conditioning	15

1. Electrical reject devices from the same production lot may be used for samples.
2. Condition A or B per paragraph 3.7 herein.
3. When fluorocarbon gross leak testing is utilized; test condition C2 shall apply as minimum.
4. Devices used in subgroup 3, "Thermal and Moisture Resistance", may be used in subgroup 4, "Mechanical".
5. Visual examination shall be in accordance with method 1010 or 1011 at a magnification of 5X to 10X.
6. Visual examination shall be performed in accordance with method 2007 for evidence of defects or damage to case, leads, or seals resulting from testing (not fixturing). Such damages shall constitute a failure.
7. Visual examination shall be in accordance with paragraph 3.3.1 of method 1009.

# 38510/MACH IV PROCUREMENT SPECIFICATION

---

## 5.0 PREPARATION FOR DELIVERY

### 5.1 Final Visual Shipping Inspection

Each lot of microcircuits and its associated documentation shall be sampled by Quality Control and visually inspected for the following:

- a) Scratched, nicked or bent leads
- b) Damaged header (packages)
- c) All test data specified in section 4.0
- d) Certificate of Compliance as specified in section 4.0
- e) All other pertinent documentation required and specified by this specification.

### 5.2 Packing Requirements

Parts shall be packed in containers of the type, size, and kind commonly used which will ensure acceptance by common carriers and safe delivery at the destination and in accordance with MIL-M-55565, Level C, bulk pack. The containers shall be clearly marked with manufacturer's name or symbol.

### 5.3 Preservation and Package Identification

The package shall be marked with the following:

The country of origin if other than U.S.A.

Procuring activity parts number

Purchase order number

Material nomenclature

Quantity

Lot number

Date code

This information shall appear on the label or shall be directly marked on each container. Method is optional.

## 6.0 NOTES

### 6.1 Precap Visual Method 2010

The following criteria may be in conflict with the circuit design topology and construction techniques of some microcircuit manufacturers. Where such a conflict does exist, the inspection criteria listed herein may be waived. (Reference paragraph 3.0 of MIL-STD-883, Method 2010).

## 38510/MACH IV PROCUREMENT SPECIFICATION

---

- 6.1.1 Preseal Visual Inspection, Test Condition B [38510 Class B (Level III) and 38510 Class C (Level I)].
- 6.1.1.1 Paragraph 3.2: a 20-PSI minimum blow-off prior to seal will be performed to meet the intent of a controlled environment.
- 6.1.1.2 For titanium-tungsten, gold, titanium-tungsten multilayered systems, the underlying metal is defined as the bottom titanium tungsten and the top layer is defined as gold.
- 6.1.2 Preseal Visual Inspection for MOS LSI devices (38510 Class B, level III SMC). When the alternate screening option of paragraph 3.3 of Method 5004 is applied, the following additional items are applicable:
- 6.1.2.1 Internal visual, Method 2010, Condition B: In addition to the changes indicated by paragraph 3.3.1 of Method 5004, the following additional clarifications and deletions are applicable as reflected in MIL-M-38510/235:
- a) Metallization inspection shall be applicable to the top layer metal conductor (i.e., Al) and need not include "underlying conductors" such as poly-silicon.
  - b) Omit paragraphs 3.2.1.1 (b) through 3.2.1.1 (e), 3.2.1.2 (b) through 3.2.1.2 (e) and 3.2.3 (e) (Items 3.2.1.1 (f) and 3.2.3 (g) do not apply).
- 6.2 Interconnections
- Circuit interconnections (metallization pattern) shall be designed so that no properly fabricated connection shall experience a current density greater than  $5 \times 10^5$  amperes/cm<sup>2</sup>, including allowances for worst-case conductor composition, normal production tolerances on design dimensions, and nominal thickness at critical areas such as contact windows.
- 6.3 X-Ray Method 2012
- Paragraph 3.9.2.2a(2) and (3) delete and replace with: "Cause for rejection shall be a single void in the bar attachment material opening two adjacent sides and exceeding 50% of the length of one side and 100% of the length of the other side."
- 6.4 Salt Atmosphere Test, Method 1009
- Where package design considerations necessitate (such as 0.75-inch tip-to-tip metal flat packs), there may be a conformal coating applied prior to the salt atmosphere test.
- 6.5 Rebonding
- Attempts to bond where only impressions have been made in the metal and where the bond did not make a physical attachment to the pad or post shall not be considered evidence of rebonding.



# IC Sockets



## IC SOCKETS

Texas Instruments lines of off-the-shelf interconnection products are designed specifically to meet the performance needs of volume commercial applications. They provide both the economy of a standard product line and performance features developed after many year's experience with custom designs. Foremost among these is our ability to selectively bond a wrought gold stripe at the contact point. No waste. Reduced cost. Reliable contacts.

### Wrought Gold Contact

Plate a contact with gold and you get a better contact. More reliable, longer lasting. Increase the gold, you improve the contact. But gold is precious, so improved performance has to be costly — right? Wrong. Because now you can get the gold only where it is needed — at the point of contact.

How? With selective metallurgical bonding; a gold stripe inlay. Not porous plating, but durable wrought gold bonded to the contact by the same technology used to produce clad coins and thermostat metals.

Texas Instruments, Attleboro, Massachusetts, is the world's largest producer of these multimetal systems. We also know our way around electronics. The result? A full line of reliable, low cost, interconnection systems featuring an extra measure of gold where it's needed. Premium performance at no premium in price.

### IC Sockets

Texas Instruments family of IC sockets includes every type and size in common use today, and as wide a choice of contact materials as you'll find anywhere. Choose from open or closed entry *wire-wrapped*<sup>†</sup> sockets, standard or low profile solder tail sockets, cable plugs, and component platforms. Sizes from 8 to 40 pins.

Additional information including pricing and delivery quotations may be obtained from your nearest TI Distributor, TI Representative, or:

Texas Instruments Incorporated  
Connector Systems Department  
MS 2-16  
Attleboro, Massachusetts 02703  
Telephone: (617) 222-2800  
TELEX: ABORA927708

<sup>†</sup>Registered trademark of Gardner-Denver

# STANDARD PROFILE SOCKET

## SOLDER TAIL

C-82 SERIES PLATED CONTACTS • C-92 SERIES GOLD CLAD CONTACTS



## WIRE WRAP

C-81 SERIES PLATED CONTACTS • C-91 SERIES GOLD CLAD CONTACTS

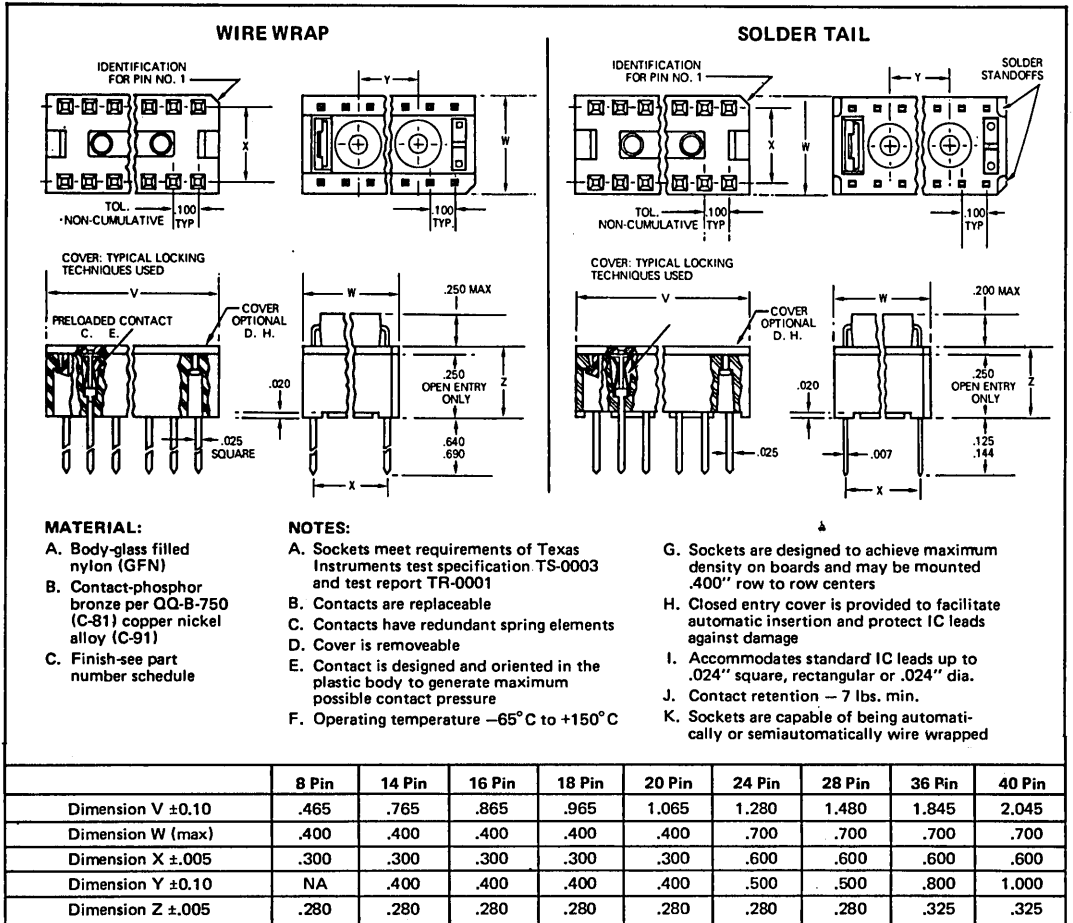

- Designed for low cost, reliable, high density production packaging
- Universal mounting and packaging capabilities
- 8 to 40 pin lead configurations
- Contacts accommodate .015" through .024" rectangular or round dual-in-line leads
- Wire wrap posts held to true position of .015" providing a true position of .020" on boards for efficient automatic wire wrapping



**WIRE WRAP**

		OPEN ENTRY	CLOSED ENTRY
<b>PART NUMBER SCHEDULE</b>			
Contact Finish	Pins	Black Body	Black Cover
Series <b>C-81</b> 200-400 microinch min tin per MIL-T-10727	8	C810854	C810804
	14	C811454	C811404
	16	C811654	C811604
	18	C811854	C811804
	20	C812054	C812004
	24	C812454	C812404
	28	C812854	C812804
	36		C813604
40		C814004	
Series <b>C-91</b> 50 microinch min gold stripe inlay	8	C910850	C910800
	14	C911450	C911400
	16	C911650	C911600
	18	C911850	C911800
	20	C912050	C912000
	24	C912450	C912400
	28	C912850	C912800
	36		C913600
40		C914000	

**SOLDER TAIL**

		OPEN ENTRY	CLOSED ENTRY
<b>PART NUMBER SCHEDULE</b>			
Contact Finish	Pins	Black Body	Black Cover
Series <b>C-82</b> 30 microinch min gold per MIL-G-45204 over 50 microinch min nickel per QQ-N-290	8	C820850	C820800
	14	C821450	C821400
	16	C821650	C821600
	18	C821850	C821800
	24	C822450	C822400
	28	C822850	C822800
	36		C823600
	40		C824000
Series <b>C-82</b> 50 microinch min gold per MIL-G-45204 over 100 microinch min nickel per QQ-N-290	8	C820852	C820802
	14	C821452	C821402
	16	C821652	C821602
	18	C821852	C821802
	24	C822452	C822402
	28	C822852	C822802
	36		C823602
	40		C824002
Series <b>C-82</b> 200-400 microinch min tin per MIL-T-10727	8	C820854	C820804
	14	C821454	C821404
	16	C821654	C821604
	18	C821854	C821804
	24	C822454	C822404
	28	C822854	C822804
	36		C823604
	40		C824004
Series <b>C-92</b> 100-microinch min gold stripe inlay	8	C920850	C920800
	14	C921450	C921400
	16	C921650	C921600
	18	C921850	C921800
	24	C922450	C922400
	28	C922850	C922800
	36		C923600
	40		C924000

# LOW PROFILE SOCKETS

## SOLDER TAIL

C-93 SERIES GOLD-CLAD CONTACTS

C-83 SERIES TIN-PLATED CONTACTS

- Universal mounting and packaging
- Anti-wicking wafer
- Stand-off tabs on base for solder flush
- Redundant contact points for low contact resistance, high reliability and repetitive insertion
- Closed entry construction

SOLDER STANDOFF

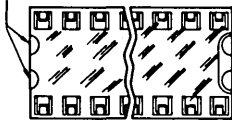

IDENTIFICATION NOTCH FOR PIN NO. 1

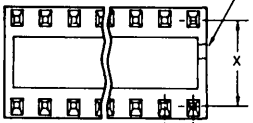

TOLERANCE NON-CUMULATIVE .100 TYP.

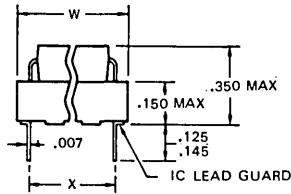
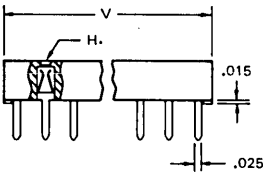

### MATERIAL:

- Body-glass filled nylon (GFN)
- Contact-copper nickel alloy
- Finish-see part number schedule

### NOTES:

- Sockets meet requirements of Texas Instruments test specification TS-0005 and test report TR-0003
- Operating temperature  $-65^{\circ}\text{C}$  to  $\pm 150^{\circ}\text{C}$
- Contacts have redundant spring elements
- Accommodates standard IC leads up to .024" square, rectangular, or .024" diameter
- Contact is designed and oriented in the plastic body to generate maximum possible contact pressure
- Socket is designed to achieve maximum density on boards
- Sockets may be mounted end to end on .100" centers continuous line or on .400" centers row to row
- Socket is designed to prevent IC leads from contacting P.C. board
- Closed entry feature provided to facilitate automatic IC insertion and protects the IC leads against damage

PART NO. SCHEDULE

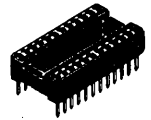

BLACK BODY

### NOMEX ANTI-WICKING WAFER

Pins	C-93 SERIES	C-83 SERIES
8	C930810	C830810
14	C931410	C831410
16	C931610	C831610
18	C931810	C831810
20	C932010	C832010
22	C932210	C832210
24	C932410	C832410
28	C932810	C832810
40	C934010	C934010

### CONTACT FINISH

C-93 SERIES:

100 microinch minimum gold stripe inlay

C-83 SERIES:

200 microinch minimum bright tin plate

	8 Pin	14 Pin	16 Pin	18 Pin	20 Pin	22 Pin	24 Pin	28 Pin	40 Pin
Dimension X $\pm .005$	.300	.300	.300	.300	.300	.400	.600	.600	.600
Dimension V $\pm .010$	.400	.700	.800	.900	1.000	1.100	1.200	1.400	2.000
Dimension W (max)	.400	.400	.400	.400	.400	.500	.700	.700	.700

