

CARRIER SYSTEMS

CARRIER SYSTEMS

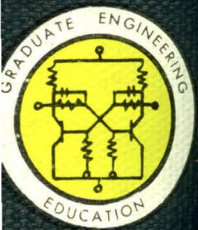

Western
Electric

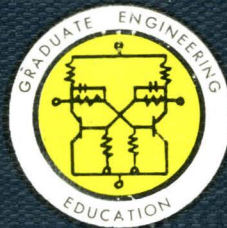

WESTERN ELECTRIC COMPANY

CARRIER SYSTEMS

1966 Edition

**Western Electric Company, Inc.
195 Broadway
New York, New York 10007**

CARRIER SYSTEMS

This material is prepared for training purposes only and is the property of Western Electric Company, Incorporated, and is loaned on condition that it be returned to the Company upon termination of employment or upon request by the Company prior thereto. No reproduction of this material, in whole or in part, and no disclosure of any part of this material to other than fellow employees, as may be necessary in connection with work assignments, may be made without prior permission in writing from the Company.

The material in this text has been compiled to give the Western Electric engineer a comprehensive survey of Bell Telephone Carrier and Radio Systems.

We would like to express our sincere appreciation to past and present members of the Graduate Engineering Training Staff and to the many other individuals within the Bell System who have given their time and effort to the organization of this book.

We wish to dedicate this book to the engineers of Western Electric who, in order to stay abreast of ever advancing technologies, must judiciously select reference materials that provide the greatest return for the time involved.

E. G. WALTERS
Manager, Graduate Engineering
Education and Technical Training
Programs

TABLE OF CONTENTS

Chapter 1	Evolution of Communications
Chapter 2	Carrier Systems - General
Chapter 3	Amplifiers
Chapter 4	Oscillators
Chapter 5	Amplitude Modulation
Chapter 6	Type "C" Carrier System
Chapter 7	Type "H" Carrier System
Chapter 8	"A" Channel Bank
Chapter 9	Type "J" Carrier System
Chapter 10	Type "K" Carrier System
Chapter 11	"L" Carrier - Terminal
Chapter 12	"L" Carrier - Transmission Line
Chapter 13	Type "N" Carrier
Chapter 14	Type "O" Carrier
Chapter 15	Type "O-N" Carrier
Chapter 16	Type "T1 PCM" Carrier
Chapter 17	Radio Systems - General
Chapter 18	"TD2" and "TD3" Radio Systems
Chapter 19	"TH" Radio System
Chapter 20	"TJ" Radio System
Chapter 21	"TL" Radio System
Chapter 22	"TM" Radio System
Chapter 23	Microwave Transmission Considerations
Chapter 24	General Considerations Involving Carrier Systems

CHAPTER 1

EVOLUTION OF COMMUNICATIONS

1.1 INTRODUCTION

People like to talk with each other. The Bell System is based on the belief that people want to talk to other people beyond the normal range of the human voice, and are willing to pay for the satisfaction of that want. The early primitive methods used for communications, such as runners to relay messages, the use of drums, birds and smoke signals serve as examples to substantiate this belief. The basic function of the Bell System is to transmit intelligence by means of electrical signals from one location to another, near or far, for the benefit of its customers.

The purpose of this chapter is to examine the evolution of methods for communications and transmission media leading up to the use of carrier.

1.2 DEVELOPMENT OF COMMUNICATION SYSTEMS

Telegraph

Due to the tremendous growth of railroads in this country and many social demands stemming from transmigration of people, the need for an efficient form of long distance intelligible signaling was needed. This need was answered by the invention of the telegraph.

A telegraph circuit in its simplest form consists of a single wire between two points, equipped at each end with a manual telegraph set consisting of a relay, sounder and key. These are so arranged that one set is connected to ground and the other to battery, or both sets connected to grounded battery of opposite polarities.

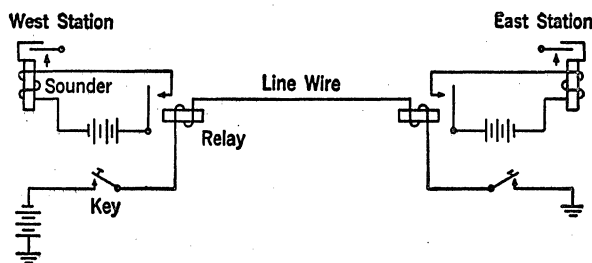

Fig. 1-1 Elementary Telegraph Circuit

CHAPTER 1 EVOLUTION OF COMMUNICATIONS

Fig. 1-1 illustrates such a simple telegraph. To analyze its operation, let us assume that the west station key is closed and ready for sending. If now the east operator closes his key for only an instant, current flows through the windings of both the east and the west relays actuating both east and west sounder, producing a complete stroke of the sounder lever corresponding to a "dot". If the key lever is held closed for a longer period, a longer interval of the up and down strokes of the sounder lever is effected producing a "dash". Proper application of "dots and dash" to a code results in intelligible signalling. To send in the opposite direction the operation is reversed.

A telegraph circuit of this kind was limited to short distances. The amount of current that could be sent over long ckt. of this type might not be sufficient to operate the receiving relays; or the signal distortion caused by such a long line might introduce errors. Hence a new need arose, this need was satisfied by the introduction of an intermediate relay at a central point in the ckt. in which the signal is reenergized by new battery connected to its contacts. This type of ckt. unfortunately, is good for only one way transmission; under these conditions it was necessary to use two conductors which is more expensive from the standpoint of the operating company. Refer to fig. 1-2.

From the subscribers point of view, the class of service it would provide might or might not be preferable. Because with the two ckt. arrangement a subscriber could send and receive at the same time providing he had two operators at each station. This is known as ("full duplex") operation.

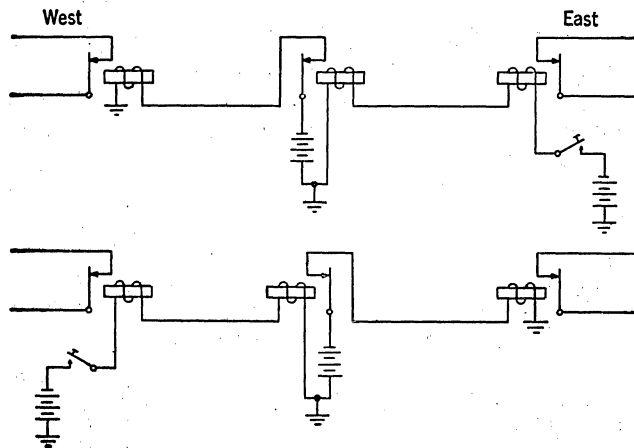

Figure 1-2

CHAPTER 1 EVOLUTION OF COMMUNICATIONS

The problem was overcome with the introduction and employment of polar relays in a complex arrangement which is worthy of separate treatment and will not be discussed further.

Telephone

While telegraph performed, and still performs a very definite function, its mode of communication was such that while the service was commercially available, people demanded a more personal means of communication. In short, the facility of talking for great distances; the need was answered by the invention of the telephone in 1876, which consisted of ruggedly constructed telephone receiver which served as both transmitter and receiver. In the simplest form of telephone ckt. two wires were terminated at each end with an instrument but without transmitter or signaling features. Figure 1-3 shows such a circuit.



Fig. 1-3 Elementary Telephone Circuit

With this arrangement it was only possible to talk for short distances. One year after the invention of the original telephone, the Blake Transmitter was introduced. This works on a principle which uses external battery as the chief source of energy and the vibrating diaphragm acts as a means for regulating or modulating this energy supply rather than as a generating supply. This device is shown in Figs. 1-4 & 1-5. The simple telephone connection between two telephone sets employing transmission receiver and its own battery supply was known as "local battery" telephone. The addition of signalling eqpt. was added and the result was a telephone subset capable of transmitting and receiving comparatively long distances. Now at this stage of development in telephony, improvement of the simple subset would offer little to the limitations as to the distance one could "talk". So logically the transmission medium needed some improvement. But in the meantime there was a great demand for the services this electronic infant could offer. Hence the development of switching facilities or central offices came about.

CHAPTER 1 EVOLUTION OF COMMUNICATIONS

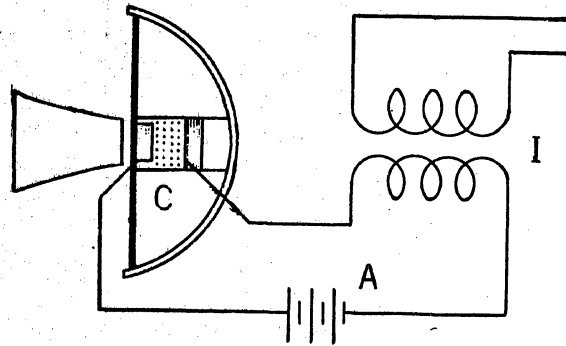
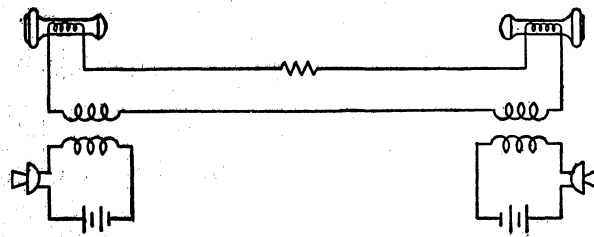

Fig. 1-4 Principle of the Telephone Transmitter

Fig. 1-5 Telephone Circuit with Local Battery Transmitters



CHAPTER 1 EVOLUTION OF COMMUNICATIONS

The first commercial telephones were used early in 1877 to connect the office of a Boston business man with his residence, a few miles away. While this worked satisfactorily and several such installations were made, it was soon realized that a telephone which could connect to only one other telephone was providing far from universal service. The first thought then was to connect each instrument by an individual line to every other instrument. Fortunately someone soon found out that the number of individual lines would be equal to $\frac{n(n-1)}{2}$, if n is the number of telephone subscribers, or in other words, that the number of lines would be nearly proportional to the square of the number of subscribers and would soon become astronomical as new subscribers were added. The solution, of course, was to connect each telephone to a central switching point, where connections between any two telephones could be established. Thus, less than two years after Dr. Bell's much quoted summons to Mr. Watson, the first commercial telephone switching office was put in service at New Haven, Connecticut on January 28, 1878.

At this stage the telephone companies had established wire communication systems whose chief attribute is that they were local, because in no case were the interconnecting telephones more than a very few miles apart.

Incidentally, these local communication systems included switching systems for the purpose of interconnecting subscribers. Apart from the means of switching, which is not treated in this text, the local systems differed from Dr. Bell's original wire communication system by inclusion of wire lines of substantial length between the telephone instruments. Thus a new set of transmission problems was added to those of the simpler system.

The transition from isolated islands of local communication systems to a more universal telephone service, by interconnecting the local systems, was not achieved overnight. Continuous effort has been spent on the problem of making such connections from the early beginnings of telephony down to the present day. Nearby communities were quickly interconnected, but the transmission problems involving longer distances were little understood in the early days. For instance, it was not until 1881, three years after the first central office for switching local telephone calls was established, that the first commercial telephone service began between Boston and Providence. This was successful because the line was operated on a metallic circuit basis (two wires) instead of the single wire, ground return method which had been employed up to that time. In 1884 the first conversation was held over a line from Boston to New York, a service made possible by the introduction of hard-drawn copper wire in place of the iron wire which had been used previously. Such lines were very costly, so the American Bell Telephone Company applied to the Massachusetts Legislature to authorize an increase in capital for the purpose of constructing new interconnecting lines between local systems. When authorization was refused, a new company was organized under the laws of New York for this

CHAPTER 1 EVOLUTION OF COMMUNICATIONS

purpose. Thus began the American Telephone and Telegraph Company in 1885. The lines which interconnected local telephone systems acquired the name of toll lines because of the extra charge imposed for conversation over long distances. Since the frequencies of electrical waves employed in transmission over these lines were confined to the range of frequencies produced by the human voice, at least in the earlier days of the American Telephone and Telegraph Company, the company may be said to have operated a voice-frequency toll wire communication system.

Voice-frequency toll systems have gone through a long period of development and improvement, and are still in use today. At first, heavier and heavier copper wires had to be used as the distances spanned grew longer under the apparently insatiable demand for long distance service. Under this condition, the cost per mile rose nearly proportionally to the distance covered. The economical results of such a situation are ultimately unhealthy, and the world's copper supply might well have been endangered if the process had continued. A series of inventions over the years reduced the attenuation per mile of the wire circuits by inductive loading, in 1899, and later made it possible to compensate for attenuation loss by amplifier gain, by use of the electron tube repeater first used in 1913, thus resulting in great savings of copper. In another development, as long distance routes became congested because of the growth of demand for many circuits over substantially the same route, cables containing many small gauge wires, which had been used over short distances in local systems for many years, were adapted to the long distance service. The trend of invention turned to methods for applying more than one circuit, or channel of communication, to a single pair of wires, thus utilizing the copper wires still more efficiently. Development of the phantom circuit, permitting three circuits on two pairs of wire, was a step in this direction. The logical outcome of the search, however, was the application of the carrier principle to wire lines. The method is to convert the audible frequencies of a communication channel to a corresponding band of frequencies centered about, or otherwise related to a particular frequency beyond the audible range, known as a carrier frequency. By suitably spacing such carrier frequencies over a comparatively wide range, several communication channels may be combined to transmit signals or voice over a single pair of wires, without interference from one channel to another. The first such carrier-frequency toll communication system went into use between Pittsburgh and Baltimore in 1918. Early carrier systems provided up to three or four additional channels, as well as the original voice-frequency channel on each pair of wires. More recent developments have provided as many as 16 channels in carrier systems designed for use on open wire lines, and in carrier systems utilizing long distance cables. In the case of open wire, two or more different carrier systems are sometimes applied to the same line, giving a total of 16 or more channels. The number of channels which a carrier system can accommodate is limited by the band of frequencies which can be transmitted economically over the

CHAPTER 1 EVOLUTION OF COMMUNICATIONS

conducting wires which are to be used. This limit appears to be between 12 and 20 for the type of conductors, open wire or cable, already in general use in the telephone plant. By making cables containing coaxial conductors, which transmit a far wider band of frequencies, the number of channels has been very greatly increased (3700 in the L-4 carrier system), and the limit had not yet been reached.

The evolution of communication systems cannot be concluded without some mention of radio systems. Recent years have seen the application of radio telephony to the plant of the telephone companies on an ever-increasing scale. Radio-frequency communication systems have been developed for specialized use in local areas, such as communication over water to nearby islands or harbor shipping, and over land to moving vehicles. Longer-haul radio systems provide service to ships at sea, and across the ocean to foreign countries. Another development, the radio relay system, follows in logical sequence the coaxial cable carrier system. The radio relay systems operate in the microwave region of the frequency spectrum and transmit such a wide band of frequencies that many hundreds of telephone channels can be accommodated. Detailed discussion of them will be covered later in this text.

1.3 APPLICATION OF SYSTEMS TO STRUCTURE OF EXISTING PHYSICAL PLANT

The modern name for local telephone communication systems is exchange area systems, or, more briefly, exchanges. The boundaries of an exchange area are fixed and defined legally, having been settled upon in the process of working out with state regulatory bodies what rates are to be charged. Thus an exchange area system may contain a single central office, or several interconnected central offices. An exchange, therefore, is not a synonym for central office, but rather a complete local system. In this system the subscriber set is connected to his central office by means of a subscriber line, or loop, a term which originated in telegraph practice, years before the invention of the telephone. Physically, the loop consists of a pair of wires mostly in cable or, in outlying districts, on a pole line. At the central office, there are intricate arrangements for connecting one subscriber to any other.

Figure 1-6 shows the position of toll systems in the telephone plant. An important difference between toll and exchange area systems, as they are usually thought of, is that whereas the latter includes all apparatus necessary to conduct a conversation, from the calling transmitter to the called receiver, a toll system is merely a link or part of a link between two separate exchange area systems. No conversation could be held over the toll system by itself, without the inclusion of at least parts of exchange area systems. In the usual arrangement of the exchange plant for toll calls, a toll connecting trunk connects the calling central office equipment

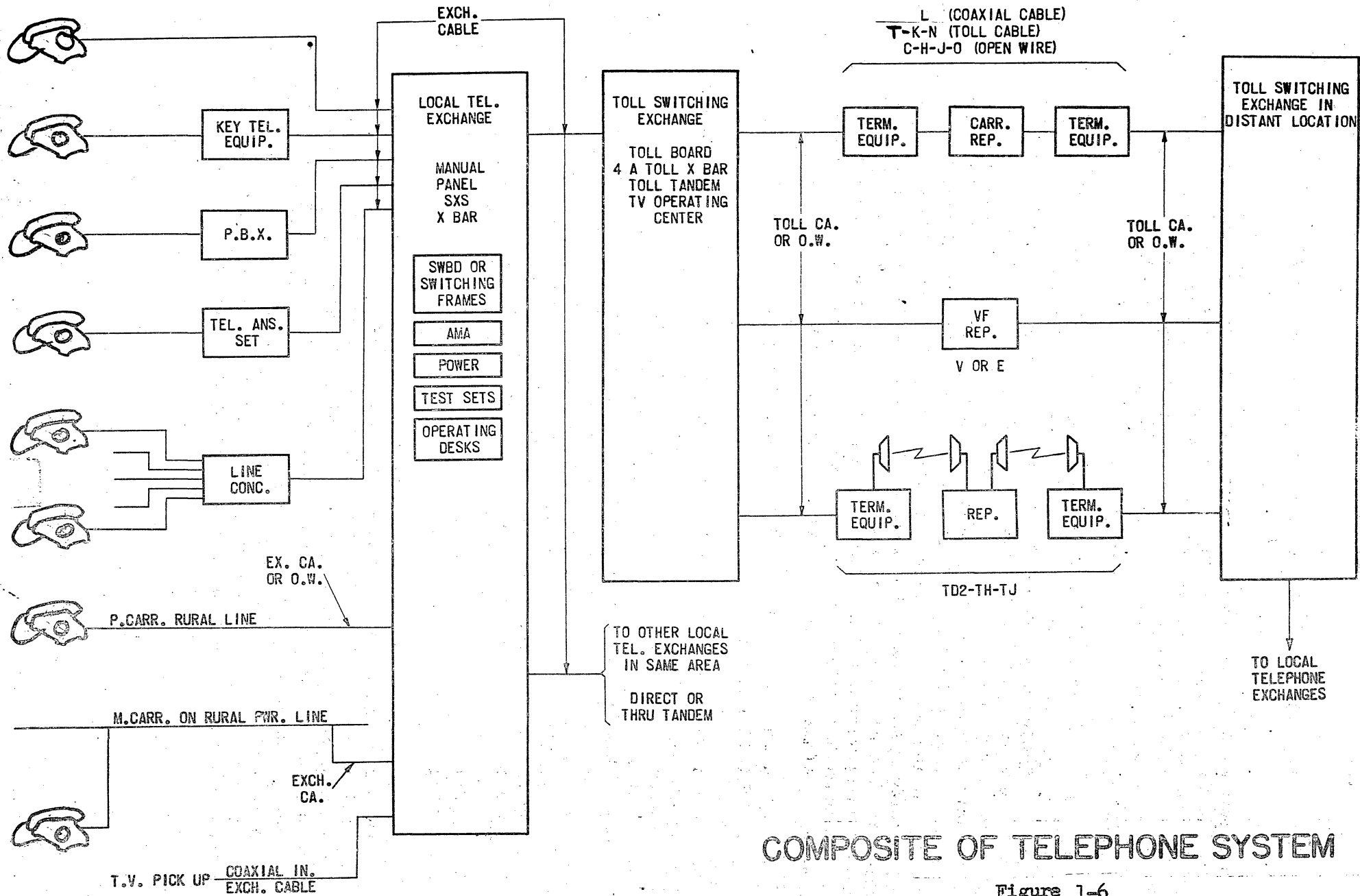

COMPOSITE OF TELEPHONE SYSTEM

Figure 1-6

CHAPTER 1 EVOLUTION OF COMMUNICATIONS

to the calling toll office equipment. A similar arrangement is made in the exchange plant at the called end. The link between the two toll offices, which may be in different cities many miles apart, may be a circuit (single link) or several circuits connected in tandem at intervening toll offices (multilink). These circuits in turn may consist of a channel in either a voice-frequency toll system, a carrier-frequency system or a radio system, or any combination of these. Thus a long circuit may be composed of as many as six or seven permanently connected sections, each part of a different toll system. A multilink toll connection may have such circuits switched together, although most of these circuits would probably consist of not more than one or two different facilities. Such cases are extreme. A toll connection between, say, Joplin, Missouri and Stamford, Connecticut, is more representative of an average multilink connection. This connection might consist of three circuits, Joplin to Kansas City, Kansas City to New York, and New York to Stamford, the switched connections being made at Kansas City and New York. The Joplin-Kansas City circuit may be part of a 4-wire voice-frequency toll cable system, and the New York-Stamford circuit a 2-wire voice-frequency toll cable system. The middle link, Kansas City-New York in this example, consists of three sections, part of a 4-wire voice-frequency toll cable system from Kansas City to St. Louis, a channel in a type "L" coaxial carrier system from St. Louis to Chicago, and a channel in a type "K" cable carrier system from Chicago to New York. Thus the multilink consists of three circuits which are parts of five different toll systems.

1.4 GENERAL TERMS USED IN TRANSMISSION SYSTEMS

"Voice Frequency Systems" are those which transmit intelligence over the line at frequencies which fall within the useful portion of the audible spectrum, in general that lying between about 200 and 4000 cycles per second.

"Carrier Systems" are those which employ some form of modulation at each end of the circuit, so that the signal is transmitted at frequencies above the principal audible range.

"Two-Wire Operation" - By its basic nature a telephone conversation requires transmissions in both directions between the customers at opposite ends of a transmission system. In the early days of telephony, most transmissions were made over paired conductors (or wires) and the transmissions in opposite directions used the same electrical path between the customers. At switching points the two transmission path terminals of one circuit were connected through cord circuits or switching mechanisms to the two transmission path terminals of a similar circuit. This method of transmission and switching was therefore designated as two-wire operation. Refer to Fig. 1-7.

CHAPTER 1 EVOLUTION OF COMMUNICATIONS

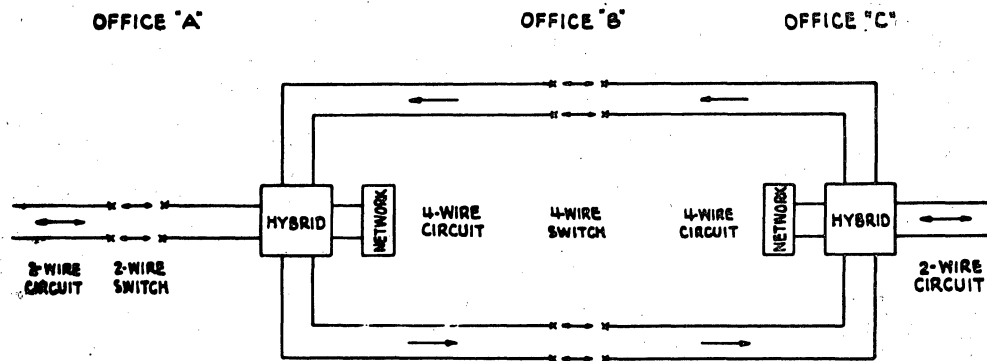

Figure 1-7 Two-Wire and Four-Wire Operations

Thus by definition, transmission and switching operations are "two-wire" when oppositely directed portions of a single conversation occur over the same electrical transmission path or channel.

"Four-Wire Operation" - When carrier system operation was introduced into the open wire plant and circuits of increasingly greater length were routed in cable plant, echo and singing considerations made it necessary to separate the electrical paths used for oppositely directed transmissions between the customers involved in a single conversation. This separation is accomplished by either or both of two methods, as follows:

- a. Separate pairs in outside plant and office cabling
- b. Separate carrier frequency bands

In the larger intertoll switching mechanisms used today such separation is also maintained through the switches.

Because two separate pairs (or 4 wires) were used for the oppositely directed transmission paths of many of the longer voice-frequency circuits in cable, circuits operated in this manner were designated as "Four-Wire" circuits.

Thus, by definition, transmission and switching operations are "Four-Wire" when the oppositely directed portions of a single conversation are routed over separate electrical transmission paths or channels.

A distinction is sometimes made between the two methods of four-wire operation. Systems using the same frequency band in two separate paths for the two directions are said to give "real four-wire operation"; those using two frequency bands over a single path are said to provide "equivalent four-wire operation". Refer to Fig. 1-7.

CHAPTER 1 EVOLUTION OF COMMUNICATIONS

"Frogging" - In railroad operations it is sometimes necessary for rails to cross each other. The device used at such cross-over points is known as a "Frog" in railroad vernacular.

In telephone operations, it is sometimes necessary to cross over from one electrical transmission path to another at some point other than at a switching center. Such cross-overs are made to equalize transmission losses or to reduce cross-talk between circuits. This is done by:

- a. Interchanging circuits between two parallel cables at an intermediate repeater station.
- b. Interchanging high and low frequency carrier system allocations at an intermediate repeater station.

By definition the interchange, or cross-over of one transmission path or channel to another at some point other than at a switching point has been designated as "Frogging".

Loading

Open Wire Loading

Open wire telephone transmission lines are subject to attenuation as a result of their characteristic impedance, capacitance and inductance. Attenuation is also a function of the frequency being transmitted and in telephony results in distortion. Thus for example frequencies at the upper end of the voice range might suffer more attenuation than frequencies at the lower end of the range. In practice the longer the lines the worse the attenuation. In 1883 it was proposed that the inductance of telephone lines be increased above the amount natural for inter-axial spacing, with a view to counteracting the more harmful effects of the line capacity. This was in answer to the need to provide an auxiliary device which would overcome the limitation of long distance transmission, even over a copper line of only 900 miles.

Increased inductance if properly chosen and applied would decrease or eliminate distortion by making the line's effect on fundamentals and harmonics more nearly uniform, and as well should reduce the attenuation by neutralizing the action of the line capacity in dissipating energy. It wasn't until 1899, however that a professor by the name of Michael Pupin developed a practical load coil. Loading was used on open wire extensively before repeaters were developed. Loading is applied by inserting inductance coils at regularly spaced intervals along the lines. This effectively breaks up the loaded ckt. into network sections. Such a network has the essential characteristics of a "Low Pass Filter" which provides for a low "Cut-Off Value", which is that critical value, at which reactance increases very rapidly with any increase in frequency. This factor obviates the use of loading on high frequency carrier systems except for entrance cable loading.

CHAPTER 1 EVOLUTION OF COMMUNICATION

Loading of open wires helped make it possible in 1914 for the A. T. & T. to join the Pacific and the Atlantic seaboard with a transcontinental line. Loading however has been generally discontinued today due to changes in attenuation characteristics of open wire circuits, particularly leakage, with varying weather changes. For an example in dry weather loading effectively reduces attenuation, but in wet weather loading may actually increase the attenuation. In order to increase the overall transmission stability of such circuits, accordingly, most loading was removed after the telephone repeater came into general use, and the resulting increase of attenuation was compensated for by the employment of additional repeaters.

Toll Cable Loading

The use of cable conductors for long distance telephone transmission in the early days had many difficulties to resolve. For wire conductors inside a cable, due to obvious economic reasons are much smaller than those used in open wire, hence the attenuation was much higher than that of open wire per unit length. The fact that the conductors were much closer together increases the capacitance and adds to the loss. Therefore in general, cable conductors used for voice-frequency transmission are loaded.

Before the development of telephone repeaters, toll cables of the largest possible gauge conductor within the norms of practicability as #10, 13 & 16 were used and loading was "heavy".

Heavy Loading while effectively reducing attenuation, has some undesirable effects, in the first place it reduces the velocity of propagation to relatively low values which may seriously interfere with effective transmission over extremely long circuits. Also, such a loaded circuit acts as a low-pass filter with a relatively low cut-off value which in some cases was around 2500 cycles.

Requirements for good fidelity in transmission requires that the cut-off points be higher than this.

It is desirable that the common telephone circuit transmit frequencies up to at least 3000 cycles and if used for program transmission work, must be substantially higher. There has been because of this, a tendency to use lighter and lighter loading in cable circuits - that is, to employ load coils of lower inductance and spaced closer together. At the same time the use of telephone repeaters has made it possible to use finer gauge conductors in toll cables, so that now practically all conductors in toll cables are now either 16- or 19-gauge.

CHAPTER 2

CARRIER SYSTEMS - GENERAL

2.1 INTRODUCTION

All of the carrier systems, except the type "L" which requires coaxial cables, are designed to be applicable to one or more of the already existing standard types of line facilities. To apply a carrier system to a line requires the addition of the carrier terminals and repeaters, and frequently also, special treatment of the line itself such as the carrier transposing of open-wire lines or the balancing of cables. The cost of this equipment and line treatment therefore represents the cost of the telephone channels furnished by the carrier system.

A carrier system would not be used unless it proved in economically. For a carrier system to prove in, the cost of obtaining additional telephone channels by means of the carrier system must be less than the cost of obtaining the same number of channels on that route by other means, such as by stringing new wires or cables and equipping them with voice frequency systems. An important part of the cost of carrier systems is the cost of the terminals. This is a fixed cost per system regardless of its length, for a particular type of system, but when expressed in terms of cost per mile, it looms up as a much larger part of the total cost on short than on long systems. It follows that for each type of carrier system, there is some minimum length of system below which the carrier costs per telephone channel mile are so great that the system does not prove in, and it is more economical to obtain the telephone channels by other means.

The fact that carrier systems have tended to prove in more naturally and by larger margins on long than on short circuits, has had a large effect on the engineering of the telephone plant. This effect has been to drive voice-frequency systems out of the long toll circuit field and to relegate them more to the shorter circuits which feed the main toll routes, as noted in the preceding chapter. Today, practically all circuits over 500 miles long and many shorter ones, are carrier circuits. The trend toward the use of carrier for long circuits receives added impetus from the fact that better transmission performance can be obtained from long carrier systems than from long voice-frequency systems.

It is evident that the carrier systems increase the efficiency of use of the wire lines by the principle of superimposition. That is, they add additional speech channels to the line, each utilizing an otherwise unused part of the frequency band. For example, when a type "C" carrier system is added to an open-wire pair, three additional 2-way telephone channels are superimposed above the regular voice-frequency channel, using frequencies

CHAPTER 2 CARRIER SYSTEMS - GENERAL

up to about 30 kilocycles. To the same pair can be further added a type "J" carrier system furnishing twelve more channels in the frequencies between about 36 and 140 kilocycles. When both systems are used, the open-wire pair furnishes sixteen two-way toll telephone circuits.

It is quite possible that in the future other methods of multiplying the number of channels that a line can transmit may be developed. For example, there is frequent engineering speculation about the possibility of applying the technique of pulse modulation, used in the radio art, to wire line transmission (or perhaps to transmission over long distance wave guides). This would be a time rather than a frequency superposition of channels, since each of the different channels would correspond to certain allotted pulses of the very large number which would be transmitted per second.

The purpose of this chapter, is to focus our attention on the carrier techniques in use in present kinds of systems. We therefore proceed in the next section with a general description of the features common to the standard carrier systems.

2.2 GENERAL FEATURES OF CARRIER SYSTEMS

With the exception of the original type "A" and the short-haul type "G" carrier systems, all of the carrier systems which have been standardized for use on wire lines operate on a "4-wire" basis. That is, each voice-frequency telephone channel handled by the system is divided by means of hybrid circuits at the system terminals into two oppositely directed one-way channels which are kept separate and distinct from one end of the system to the other. The carrier systems therefore begin and end with voice-frequency hybrid circuits. The two one-way channels are kept separate during transmission between the terminals by one of two methods: either by transmitting them over different pairs, or else by transmitting them at different carrier frequencies over the same pair.

Each one-way voice channel is translated in frequency to the band allocated to that channel on the line by a process called modulation. This frequency shift is made in a single stage of modulation in some systems, and in others, two or even three stages of modulation are used. At the receiving end of the system, the channel is shifted back to its original voice-frequency band by an inverse process of modulation (usually called demodulation) in one to three stages. The principles of modulation, and typical circuits of modulators are described in another chapter of this text. The following general remarks may be made at this point.

The type of modulation employed in all of the systems is that known as amplitude modulation (AM, in radio language). It is well known, as shown later, that when the amplitude of a carrier wave is modulated by a signal, the result is a wave composed of the carrier frequency plus an upper and a

CHAPTER 2 CARRIER SYSTEMS - GENERAL

lower sideband which differ from the carrier frequency by the frequency of the signal. It is evident that the two sidebands are redundant, either by itself carrying all of the intelligence of the signal, and that the carrier is superfluous, carrying no intelligence at all. Therefore in most of the multichannel systems, maximum efficiency is attained by removing the carrier and one sideband by means of filters, and transmitting only the other sideband. However, in certain of the systems where economy is a main object, both of the sidebands and perhaps also the carrier are transmitted.

When single-sideband transmission is employed, it is evident that the carrier signal in a given channel has the same bandwidth as the original voice-frequency channel. The single sidebands corresponding to the different telephone channels handled by the system are usually placed in adjacent positions in the carrier frequency band, one every 4 kilocycles. With modern filters this permits a useful band for each channel which is somewhat wider than 3 kilocycles. It will be shown later that single-sideband transmission, though physically derived by a process of amplitude modulation, is as closely related to frequency modulation as it is to AM. It is a very efficient method of transmission.

An important feature of every carrier system thus consists of the modulators and demodulators which shift the frequencies of the telephone signals.

Another feature of all carrier systems is the need to select the desired signals from the modulators for transmission to the line, and to separate the line channels from each other for application to their respective demodulators, at the receiving end of the line. Filters are also used to separate groups of channels for each other.

The signals are usually transmitted over the lines between the terminals in two groups, one consisting of the E-W (east-to-west) one-way channels of all the telephone circuits handled by the system, and the other consisting of the W-E (west-to-east) one-way channels of the same telephone circuits. As noted earlier, the two groups may be transmitted over different pairs, or over the same pair in different frequency ranges. The channels constituting a group are amplified by one common carrier line amplifier (or repeater) at each repeater point.

The lines, of course, have considerably greater attenuation at the higher frequencies needed for carrier transmission than at voice frequencies. Therefore carrier line amplifiers must be spaced at much shorter intervals along the line than must voice-frequency repeaters. The length of the repeater sections on any system is a function of the line attenuation, the standards for allowable noise at the end of the system on each telephone channel, the maximum length of system, the noise on the line sections and in the amplifiers, and, in the case of multichannel systems, of the amount of modulation in the line amplifiers. Since the line attenuation is greatest

CHAPTER 2 CARRIER SYSTEMS - GENERAL

for the highest frequency channel transmitted by the system, the repeater spacing is usually determined by the rules as applied to that channel.

Because the line attenuation is great at the carrier frequencies, the variation in attenuation with temperature (and with weather in the case of open-wire lines) is also large. Furthermore, both because of the large attenuation and also because of the wide frequency band required for most carrier systems, the difference in attenuation between the highest and lowest transmitted frequency is large. These considerations impose **severe** transmission problems on the carrier systems which are solved in different ways on the various systems.

The variations of the lines with frequency and temperature are compensated for by equipment associated with the line amplifiers. It will be noted that though the total effects to be compensated may have hyperastronomical magnitudes, the distribution of the compensation among many line amplifiers reduces the problem at each amplifier to manageable proportions. The equipment which does the compensating falls in two categories, namely, basic equalizers which compensate for the attenuation-versus-frequency distortion of the lines under mean ambient conditions, and regulating networks which adjust for the variations in the attenuation and in the attenuation-versus-frequency characteristics of the line due to changes in temperature (and other causes). The regulating networks are automatically operated, usually under control of one or more pilot frequencies wedged in between the telephone channels. In some cases, the flat gain variations may be controlled by a d-c pilot channel similar to that used in the pilot-wire regulators of voice-frequency systems, or by the energy in the carrier channels themselves. The specific application of the techniques to the various carrier systems is described in later chapters.

The pilot frequencies, when used, are of course supplied by the system terminals. Another feature of carrier terminals, therefore, consists of the means for generating the pilot frequencies, and also the carrier frequencies required by the various modulators and demodulators. In most systems, these frequencies must be very exact in order that the signal and pilot frequencies will accurately match the pass bands of the filters through which they must be transmitted, and that they will fall properly into their allotted frequency positions on the lines. It may be noted that in those systems in which the carrier is not transmitted, which is the case with most of the systems, the carriers supplied to the modulators and demodulators at the two ends of the system must be generated by physically separated oscillators. Any actual difference between the carrier frequencies at the two ends, which ideally should be identical, results in a corresponding displacement of the same number of cycles in all the frequencies in the telephone signals emerging from the system. The tolerance for such frequency displacements is at most a few cycles, which in terms of per cent error in the carrier frequencies necessitates considerable accuracy.

CHAPTER 2 CARRIER SYSTEMS - GENERAL

2.3 FUNDAMENTALS OF CARRIER TELEPHONE SYSTEMS

In ordinary telephone transmission a pair of wires between telephone subscribers ordinarily carries one conversation and is required to transmit intelligence or voice frequency energy in both directions. In other words, we speak and hear over the same pair. This is called a two-wire system and is possible because of the circuit arrangement of the subscribers instrument. Figure 2-1.

If we attempt to use one pair for more than one conversation at one time, we succeed only in making a four person conference out of it in which each person can hear everything everyone else says. Adding more instruments only adds more confusion. Figure 2-2.

Changing to a four-wire system has definite advantages in carrier telephony. Since we are developing a simple carrier system we will convert our circuit to "four wire." This simply means that when A talks to B, one pair is used. When B talks to A, a different pair is used. Even with our simple telephone circuit the confusion has been reduced somewhat since now only two receivers can be actuated by any one transmitter. Figure 3-3.

Speech transmitted over telephone lines, generally speaking, is in the range of 300 to 3500 cycles per second. If we can change the frequency range of the speech of customers A1 and B1 from the 300 to 3500 cycle range to a range of, say 4300 to 7500 cycles and, further, arrange to separate the A-B from the A1-B1 conversations at the receiving ends of the circuit, we can use two pairs of wires for two separate conversations or even more with a saving in plant investment. This is the beginning of a carrier system.

Carrier telephony consists of superimposing voice frequencies on a carrier frequency and then transmitting this information to a point where the reverse will occur. The normal range of voice frequencies is 50 to 8000 cycles or higher. For telephone use a range of 300 to 3500 cycles is used. This range will allow one subscriber to identify any other subscriber. The carrier frequencies are steady frequencies other than voice frequencies, usually higher than the voice range. The superimposing is the modulation spoken of earlier in this chapter.

When the voice frequency is superimposed or impressed on the carrier frequency for amplitude modulation there is obtained, among other things the sum and the difference of the two frequencies. For example if we let:

V = voice frequency

C = carrier frequency

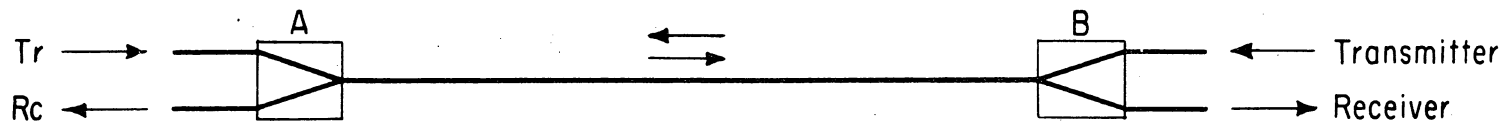

FIG. 2-1

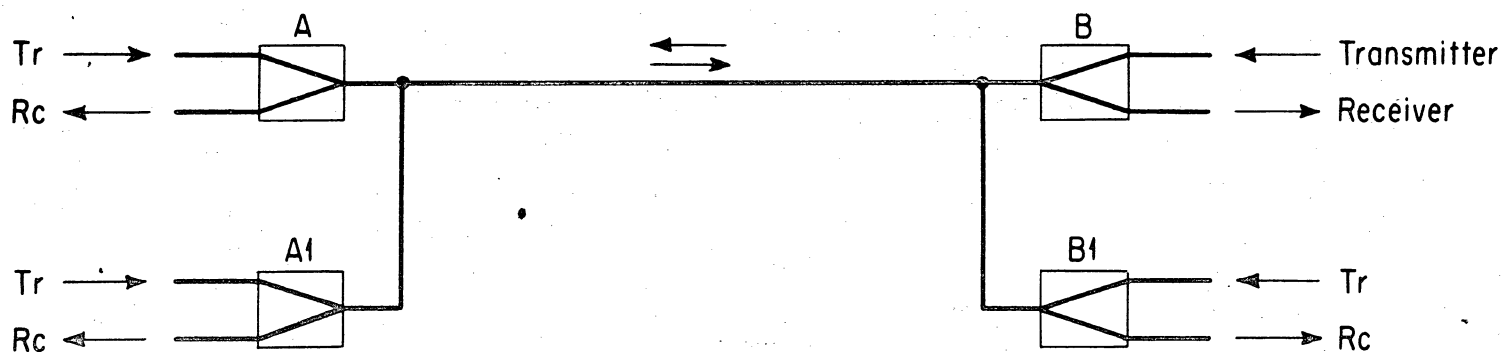

FIG. 2-2

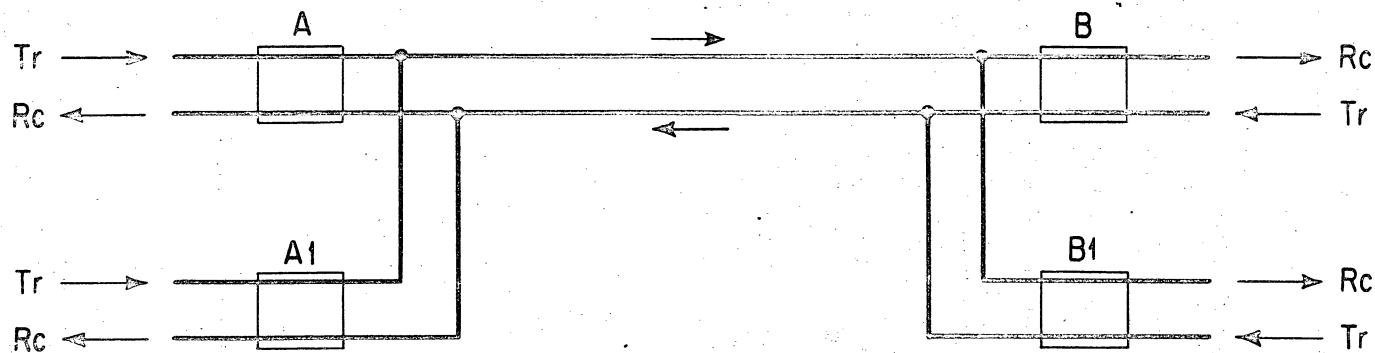

FIG. 2-3

2.6

CHAPTER 2 CARRIER SYSTEMS - GENERAL

Then the results of modulation may be expressed in the basic formula:

$$C \pm V = \text{frequency output} \quad (2:1)$$

Using the voice frequency band 300 to 3500 cycles and assuming a carrier frequency of 7000 cycles $C + V = 7000 + (300 \text{ to } 3500) = 7300 \text{ to } 10,500$
 $C - V = 7000 - (300 \text{ to } 3500) = 3500 \text{ to } 6,700$

The band of $C + V$ is called the upper sideband and the band of $C - V$ is called the lower sideband. The reverse process is called demodulation and the voice frequency is obtained. For testing on a carrier system the average of the voice frequency - 1000 cycles is used.

2.4 A SIMPLE CARRIER SYSTEM

Now we can develop a simple carrier system in which two subscribers A and B may talk together without interfering with, or being interfered with, by two other subscribers A1 and B1, when they are using the same wire conductors for the talking path.

Lets start with two signal generators at one end of a two wire line as in Figure 2-4. The generators will produce frequencies of 1000 and 8000 cycles respectively. On the line we have a mixture of the two frequencies. By inserting a low pass filter and a high pass filter at the receiving ends as in Figure 2-5, the two frequencies can be separated. Each receiver would then operate independently of the other.

Now lets change the talking circuit of Figure 2-3 to a simple carrier system. Additional equipment is necessary if we are to accomplish our objective. In Figure 2-6 this equipment is added and designated C. They are carrier components. If we specify that they are to meet certain requirements we will have a simple two-channel carrier system. These requirements are shown on Figure 2-6. The blocks designated C are the filters, modulators and demodulators required in carrier systems.

These are the principles upon which all carrier is based. They are also the principles upon which your radio and television sets are based. The only two ideas involved are those of changing frequencies from one band to another and filtering out or removing unwanted frequencies. By adding detail and more channels we can arrive at various carrier systems, but no matter how complicated the details may seem, the fundamental ideas are the same.

Due to the fact that losses occur in the transmission of any type of energy resulting in the gradual dying out or attenuation of that energy, it is necessary to use amplifiers or repeaters at intervals determined by the losses encountered. Although only one is shown, the average carrier system has several such repeaters. Figure 2-7.

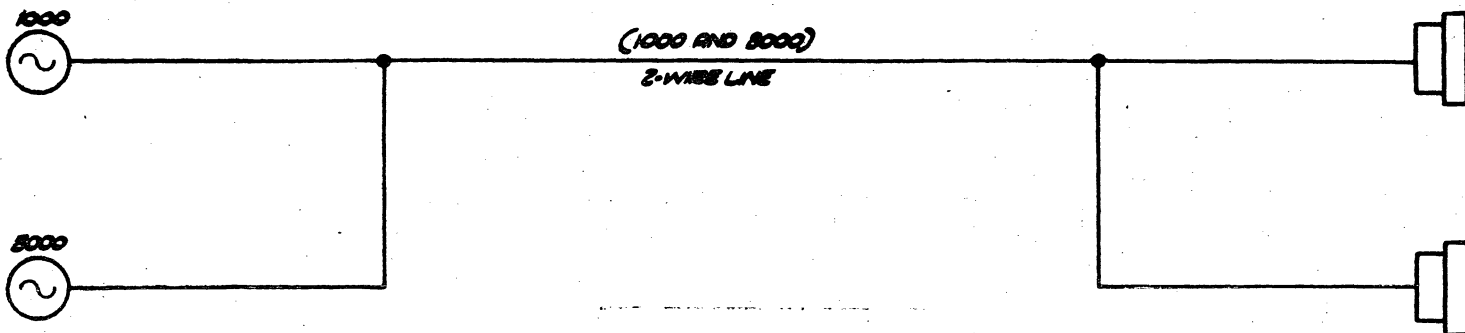

Fig. 2-4

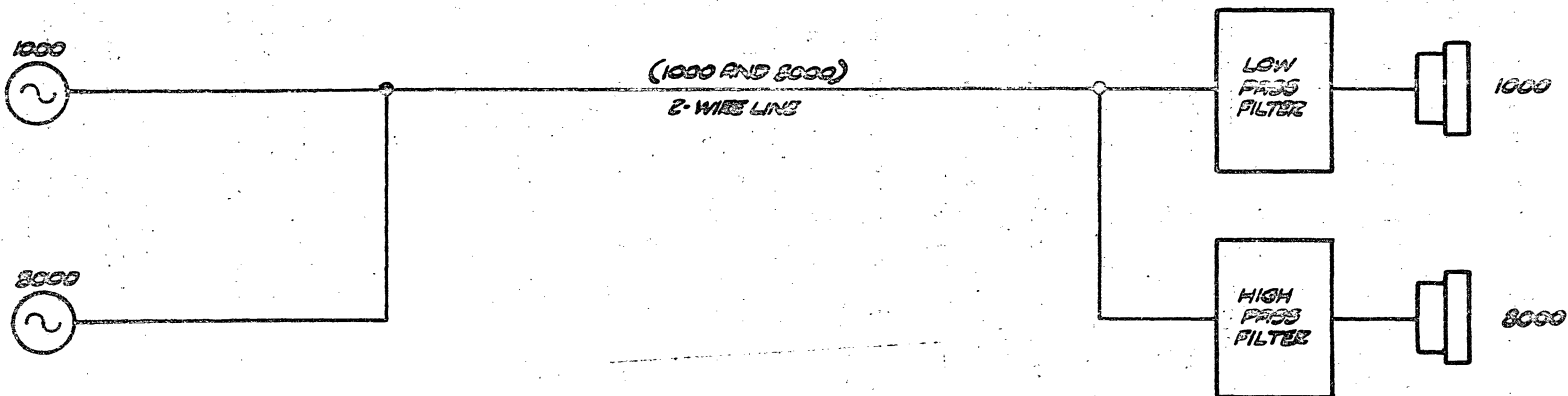

Fig. 2-5

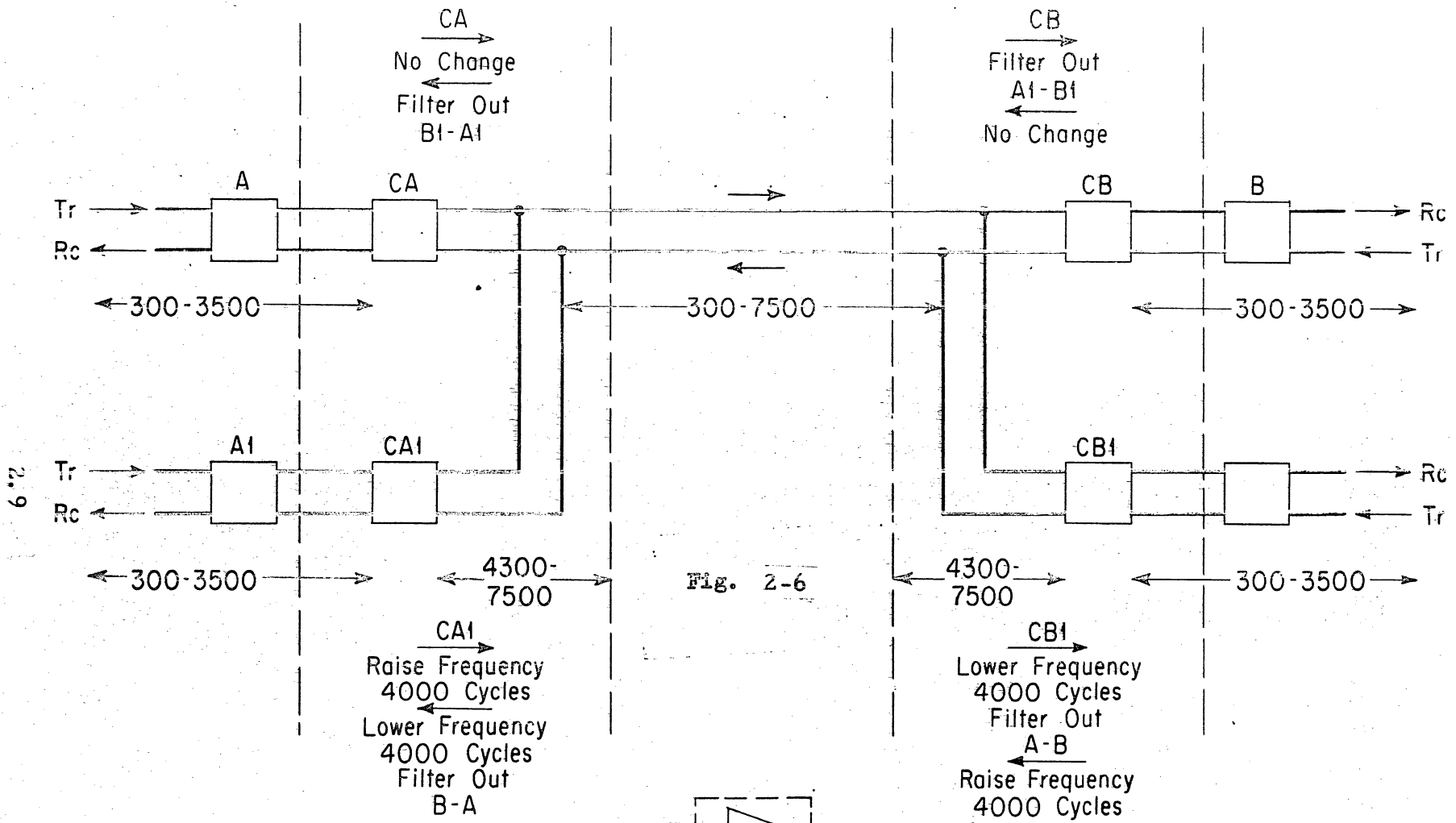

Fig. 2-6

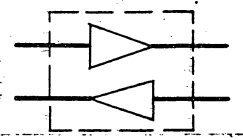

Fig. 2-7
Repeater

CHAPTER 2 CARRIER SYSTEMS - GENERAL

2.5 A TYPICAL CARRIER SYSTEM TERMINAL

A carrier terminal Figure 2-8 may be divided into three portions, the voice frequency, transmitting and receiving portion.

In the voice frequency portion the low pass filter (V) allows the voice frequency channel to pass through but blocks the carrier frequencies. The high pass filter lets carrier frequencies into carrier equipment while it blocks out the voice frequencies. This path is established for one message circuit, receiving and transmitting.

In the transmitting portion of Figure 2-8, the voice frequencies from the subscriber are directed into the transmitting portion of the carrier channel by the hybrid coil. The low pass filter (T) eliminates any undesirable frequencies outside of the voice frequency band 300 to 3500 cycles. The oscillator produces the carrier frequency. Each terminal has its own oscillator. The modulator impresses the voice frequency band on the carrier frequency and produces the upper and lower sidebands. In most carrier systems only one sideband is transmitted and this is called Single Sideband transmission. The band pass filter removes all frequencies except one of the sidebands.

Generally on open wire carrier systems one sideband ($C + V$ for example) is transmitted in one direction of transmission and the other sideband ($C - V$) is transmitted in the other direction. Carrier systems used on cable generally use separate pairs for transmission in each direction, and this permits the same sidebands to be transmitted in each direction. The transmitting amplifier steps up the sideband being transmitted to the desired power level for transmission. The function of the transmitting directional filter is to keep the frequencies being received from coming into the plate circuit of the transmitting amplifier. This establishes the transmitting circuit.

In the receiving portion of the carrier terminal, the receiving directional filter blocks out the frequencies of the sideband being transmitted but allows the sideband being received to enter the receiving circuit. As the transmitted sideband is conducted to the receiver via the transmission lines the higher frequencies are attenuated more than the lower frequencies. The equalizer adds loss for the lower frequencies so that all frequencies will pass into the demodulator at the same level. The demodulator combines the carrier frequency with the received sideband and one of the resultant products is the voice frequency. The low pass filter (R) removes all the products of demodulation except the voice frequency. The receiving amplifier steps up the power level of the voice frequencies to that required for transmission to the subscriber. The receiving frequencies are then directed to the subscriber through the hybrid coil. Thus establishing the receiving circuit.

CHAPTER 2 CARRIER SYSTEMS - GENERAL

In the system just described we had two message paths over one pair of wires. It would be possible to add more message paths using this same pair of wires by adding more carrier terminals using different carrier frequencies.

The next few chapters will elaborate on amplifiers, oscillators, modulators and demodulators.

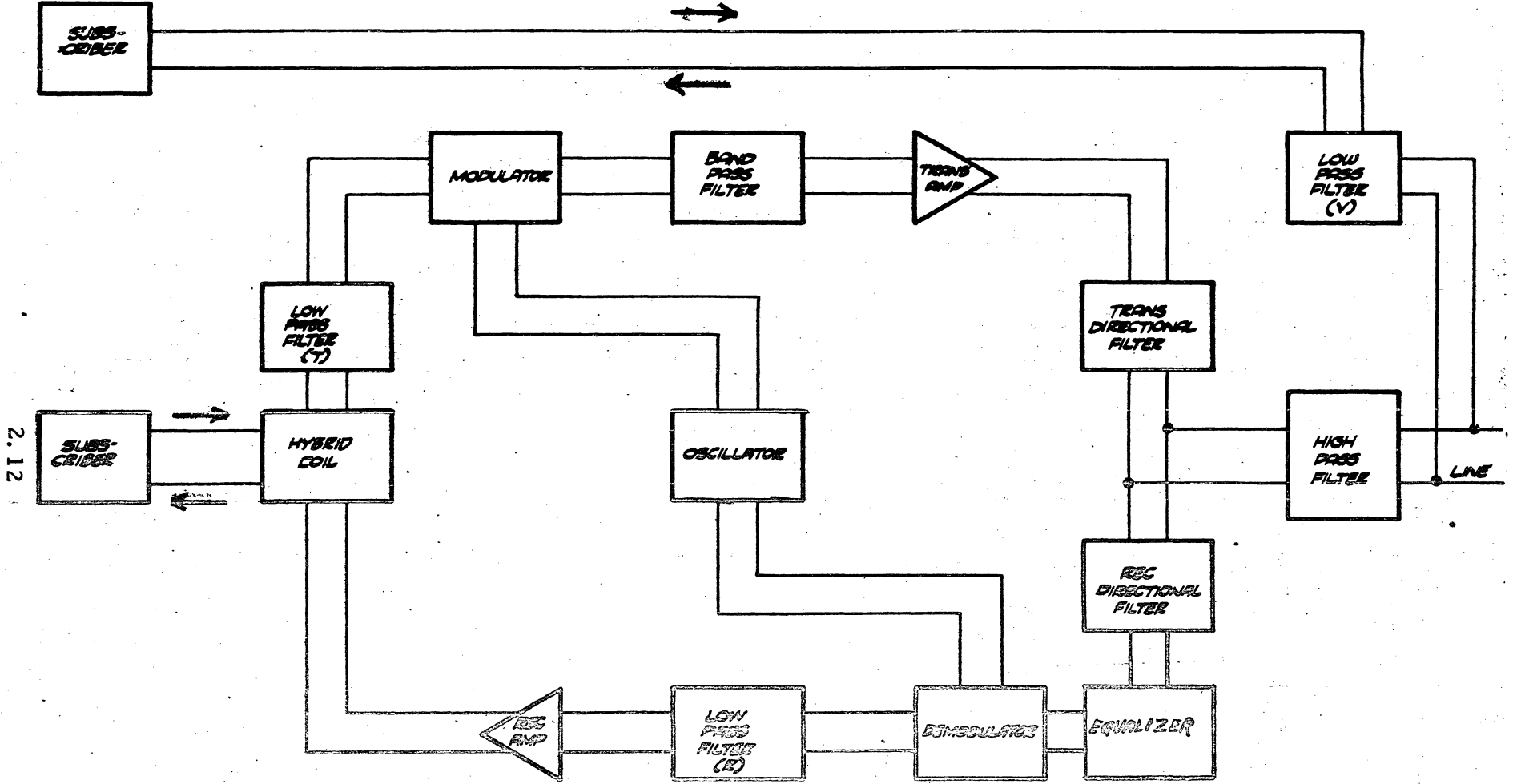

2.12

TYPICAL SINGLE CHANNEL CARRIER TERMINAL

Figure 2-8

CHAPTER 3

AMPLIFIERS

3.1 INTRODUCTION

There are many possible classifications of amplifiers, depending on the purpose for which they are to be used. One broad classification is as voltage amplifiers, or power amplifiers. Another classification depends upon the frequency range in which the amplifier is to operate. This may include audio-frequency amplifiers, broad-band amplifiers, radio-frequency amplifiers, and superhigh radio-frequency amplifiers. Again, amplifiers may be classed according to the band-width of the signal they are required to handle, i. e., whether a relatively narrow band of audio or radio frequencies, or the wide band of frequencies encountered in broad-band carrier systems and in video transmission. Any given amplifier may properly fall into more than one such classification.

3.2 THE ELECTRON TUBE

General

It is outside the scope of this text to discuss in detail the physics of the electron tube or the circuit design theory that has been built around it. This section is intended to bring out some general characteristics of the electron tube which are pertinent to its use as an amplifier.

The electron tube is a device to utilize the flow of free electrons in a vacuum or a partial vacuum. Such tubes are used as oscillators, rectifiers, amplifiers, modulators, pulse generators, pulse shapers, etc. They are building blocks which make possible long distance telephony, radio, television and many delicate control systems.

The Electron

The electron is a minute, negatively-charged particle with a mass of 9×10^{-28} gram. The electron is the smallest bit of electricity. To light an ordinary 60-watt light bulb requires a current of about one-half ampere. In terms of electrons, this means a flow of about 3×10^{18} electrons per second. For its size, the electron packs a terrific punch; to speak more formally, we may say that the charge-to-mass ratio of the electron is enormous. Imagine two spheres composed entirely of electrons, each sphere weighing one gram (1/28 ounce). Because like changes repel, there would be a force tending to push the spheres apart. If the spheres were separated by 100 km (62 miles), the repelling force would still be about three million, million, million tons!

CHAPTER 3 AMPLIFIERS

Electrons in Metals

In metallic conductors, some electrons are unbound and free to travel from atom to atom. Such unbound electrons, in the absence of external electric or magnetic forces, assume a chaotic motion. If enough additional energy from an external source is imparted to such unbound electrons, some of them will move toward the surface of the metal with sufficient velocity to break through and become, at least momentarily, free electrons.

Types of Emission

The four principal methods to obtain free electrons from solid metals are:

- a. Thermal emission, in which the metal is heated to increase the thermal energy of the unbound electrons.
- b. Photo-electric emission, in which light energy is transferred to the unbound electrons.
- c. Field emission, in which a strong electric field is applied to the surface of the metal.
- d. Secondary emission, in which the energy is supplied by electric charges bombarding the surface of the metal.

Flow of Electrons. Current

If free electrons are provided by some method of emission and if a positive collector is nearby, there will be a flow of electrons from the emitter, or cathode, to the collector, or anode. This flow of electrons, or current of electricity, is commonly measured in amperes or milli-amperes. (An ampere is one coulomb per second, or 6.24×10^{18} electrons per second.)

The Diode and Its Characteristics

The simplest electronic tube is called a diode because it has only two elements; the cathode and the anode. The cathode is usually completely surrounded by the electron-collecting anode, or plate. If the cathode is emitting sufficient electrons and if the diode is connected in series with a suitable battery, with the plate connected to the positive battery terminal, an electron current will flow from the cathode to the plate. No current can flow in the opposite direction. Figure 3-1 illustrates typical diode characteristics. It will be seen that plate current is strongly affected by the plate voltage until the plate voltage is made high enough so that saturation is approached. At the point of saturation all electrons emitted by the cathode are drawn to the plate. Further increase of plate voltage beyond the point of saturation cannot increase the current.

Figure 3-2 shows how a diode characteristic curve can be used to determine the current flow which will result when an alternating voltage is applied to the tube.

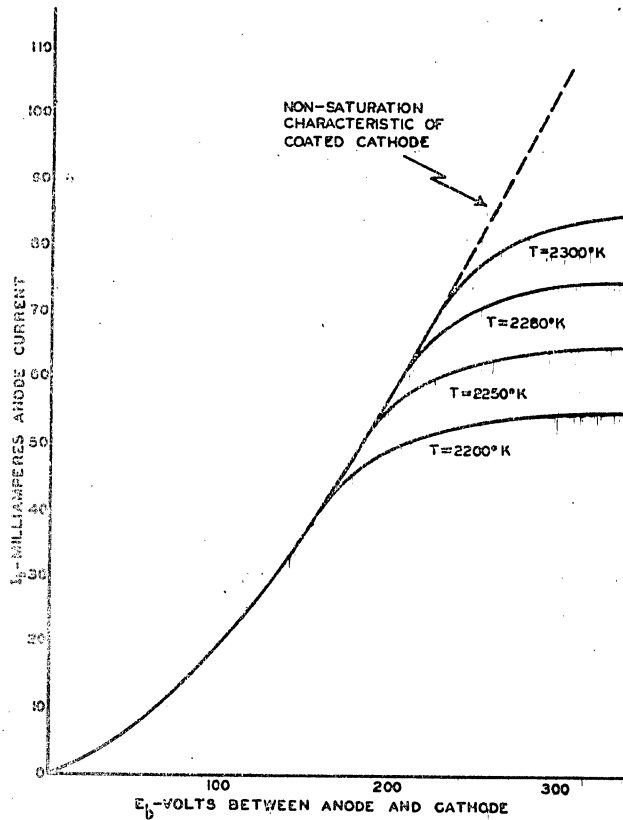

Figure 3-1

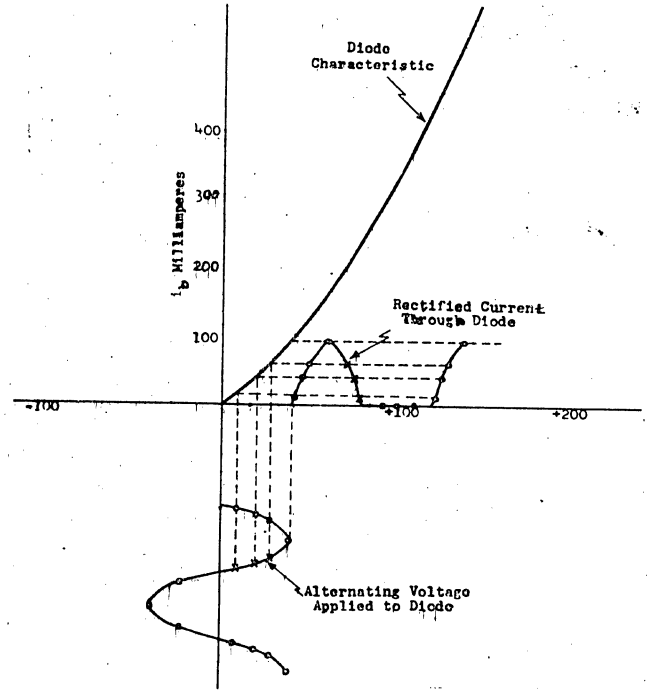

Figure 3-2. Use of Diode Characteristic to Determine Current Flow When Alternating Voltage is Applied

The Triode and Its Characteristics

In the triode a third element, called the control grid, is placed between the cathode and the plate. The grid is much closer to the cathode than is the plate; therefore, small changes in grid voltage have relatively great effect on the electron flow (plate current). If the grid is held negative with respect to the cathode, as in the circuit of Figure 3-3, then the negative grid voltage will tend to repel the electrons which are emitted by the cathode and will thus reduce the plate current. Indeed, if the grid is sufficiently negative plate current will be cut off entirely.

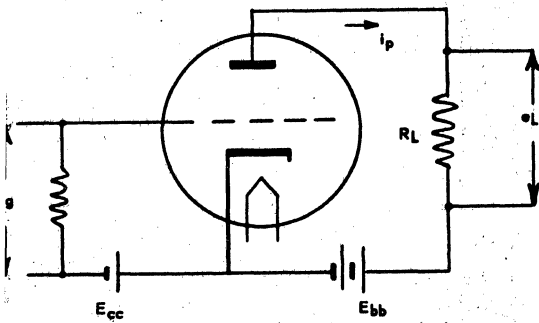

Figure 3-3. Triode Amplifier - Actual Connection

The fact that relatively small variations in grid voltage produce corresponding large variations in plate current permits use of the triode for amplification, oscillation, frequency conversion, modulation, demodulation and other circuit functions.

Other Types of Electron Tubes

Many types of electron tubes other than the diode and the triode are used regularly in our business. The tetrode was developed to provide greater stability in amplifiers. The pentode was designed to provide a

flatter characteristic than that of the tetrode. Beam power tubes, remote cutoff tubes, and special high-frequency tubes are used to fit different circuit requirements. Tubes are made in widely variant sizes and shapes in order to achieve particular characteristics. Gas-filled tubes, photo-sensitive tubes, cathode ray tubes, camera tubes, electron multipliers, velocity-modulated tubes and kinescopes are all special-service tube types which have become important in the communications industry.

Multi-Electrode Tubes

There are many designs of vacuum tubes containing more electrodes than the tubes we have been considering. Most widely used of these are four electrode tubes or tetrodes and five electrode tubes or pentodes. The basic theory of operation of such tubes is essentially the same as that of the triode. The additional electrodes act to improve the operating characteristics with respect to the amount of amplification to be obtained and may have other desirable effects.

At relatively low frequencies, the amplification factor of a triode can be made to have almost any desired value by properly spacing and proportioning the three electrodes. When tubes are used with high frequencies such as are encountered in radio and other high-frequency systems, the effect on inter-electrode capacitance becomes increasingly important. This is particularly true of the capacitance between the plate and control grid, where its coupling effect may be especially troublesome because it provides a path between the input and output of the tube through which output energy may feed back into the input circuit. This plate-control grid capacitance effect can be practically eliminated by placing a shielding grid between the control grid and the plate as illustrated in Figure 3-4. This grid is known as a screen grid, and the four-electrode tube is then known as a screen grid tetrode.

CHAPTER 3 AMPLIFIERS

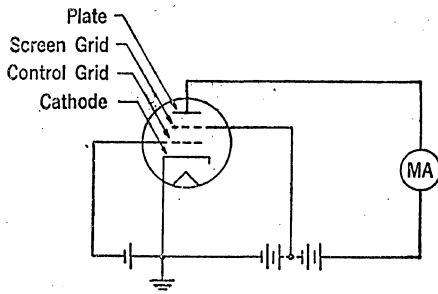

Figure 3-4 Four-Electrode Vacuum Tube

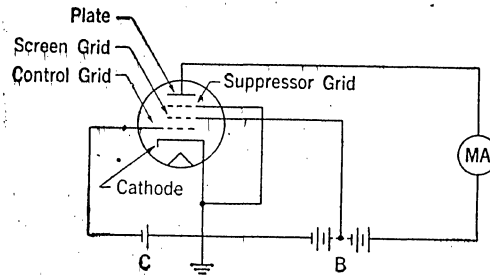

Figure 3-6 Five-Electrode Vacuum Tube

As the plate is shielded by the screen grid from the other electrodes, it (plate) has little effect in withdrawing electrons from the space charge area about the cathode. This function is taken over by the screen grid which is given a positive potential for this purpose. The flow of electrons from the cathode, and their control by the control grid, is practically the same as discussed in the case of the three-electrode tube, but in the screen grid tube, the screen grid itself may be considered as acting in somewhat the same manner as did the plate of the three-electrode tube. However, the electrons constituting the space current, on arriving in the area of the screen grid have acquired such a velocity that most of them pass through the openings in the screen grid and, attracted by the still higher positive voltage of the plate, continue on to the plate. A small portion of the electrons is, of course, intercepted by the screen grid and does not reach the plate. This is illustrated by the plate voltage vs. plate and screen grid current curves in Figure 3-5 for a representative screen-grid tetrode.

In the normal working range of the tube, where the characteristic curve is relatively flat, it will be noted that the plate current change is quite small for a considerable change in plate voltage.

This means that the output resistance of the tube is very high as compared to the triode. Due to the presence of the screen grid, the variation of plate voltage has relatively little effect on the plate current, but the control grid retains the same control of plate current as in the triode. The amplification factor is accordingly much higher.

It will be noted, however, that at plate voltages close to or less than the fixed screen grid voltage, the characteristic curves show a pronounced drop in the plate current. This is due in part to the fact that the screen under these conditions is drawing an excessive part of the cathode current because of its relatively high positive potential. More important is the fact that it is now attracting electrons emitted by the plate as a result of secondary emission. This emission is caused by the high-speed electrons striking the plate with such force as to knock some of the outer electrons out of the plate material. Under normal operating conditions these secondary electrons will fall back into the plate due to the influence of its

CHAPTER 3 AMPLIFIERS

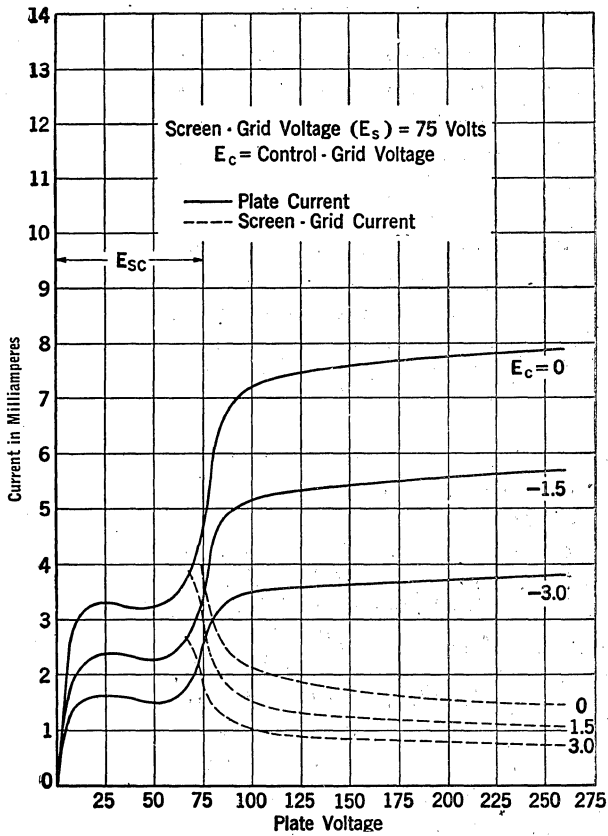

Figure 3-5 Characteristics of Four-Electrode Tube

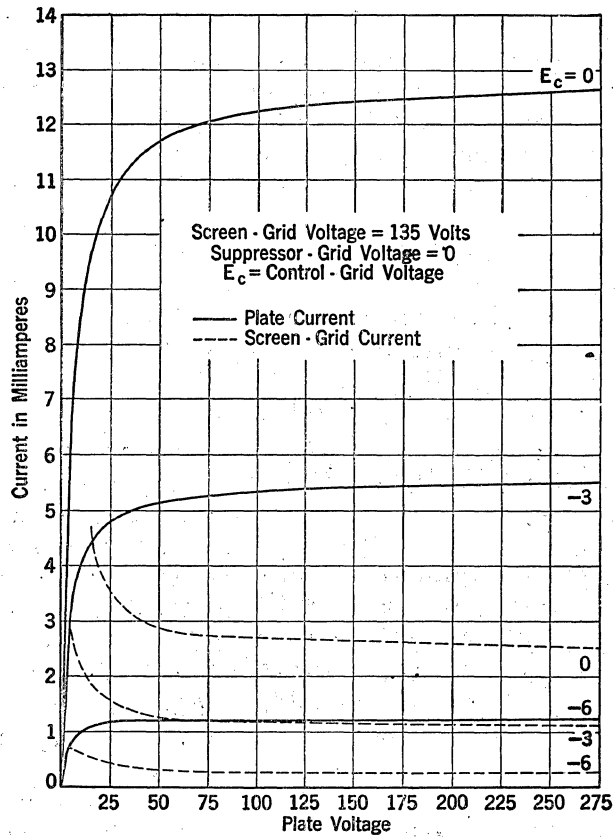

Figure 3-7 Characteristics of Five-Electrode Tube

positive potential; but if the screen potential is as high or higher than the plate potential, some of them will be attracted to the screen, thus effectively reducing the total flow to the plate and increasing the screen-cathode current. Obviously, operation of the tube in this region would result in marked distortion of the input signal. Generally, therefore, screen grid tubes must be operated with a plate supply voltage sufficiently high so that the maximum negative swing resulting from the control grid input signal will not reduce the instantaneous plate potential to a value approaching that of the screen.

While there is always some secondary emission of electrons from the plate of a tube, its effect on the tube's operating characteristics can be practically eliminated by introducing another grid between the plate and the screen grid, as shown in Figure 3-6. This grid, which is maintained at a potential negative with respect to the plate, is called a "suppressor grid" and the tube then becomes a suppressor-grid pentode. The

CHAPTER 3 AMPLIFIERS

suppressor grid is usually connected directly to the cathode, often inside the tube. Its field repels the secondary electrons emitted from the plate, forcing them back to the plate. Figure 3-7 shows characteristic curves for a tube of this type. It will be noted that like the screen grid tetrode, both the amplification factor and output resistance are high.

There are many other possible designs of multi-electrode tubes, some practical types of which contain as many as eight electrodes. It is customary also to employ multi-unit tubes in which two or more independent electronic circuits are included in a single envelope. The structure of such tubes is indicated by their designations such, for example, as duplex-diode-triode, twin-pentode, etc.

3.3 SEMI-CONDUCTORS

General

Of the semi-conducting materials currently in general use in electrical communications practice the metallic element, germanium, has perhaps been most thoroughly studied. Techniques have been developed for refining it to an almost incredible degree of purity and for processing it in the form of single crystals which can be treated or "doped" with impurity substances in any desired proportion. Unless specifically stated otherwise, the following discussion will be confined to this material. The principles developed will apply in general to all other semi-conductors, although their specific characteristics may of course differ.

Germanium is a metal which in ordinary electrical practice would be considered a very poor conductor. At room temperatures, typical "n-type" germanium, such as might be used in a transistor, contains one free electron for about 10^8 atoms as compared with one free electron for each atom in a good conductor such as copper. Even so, a cubic centimeter of this material includes something in the order of 10^{14} free electrons so that it is certainly not a good insulator. To understand its capabilities and limitations as a conductor, it is necessary to examine the germanium atoms and their structural arrangement in detail.

Chemically, germanium has atomic number 32 and valence 4. This means, in terms of modern atomic theory, that the atom nucleus is surrounded by four shells of orbital electrons containing 2, 8, 18, and 4 electrons. The first three shells are completely filled and so firmly bound to the nucleus that they can play no part in any practical conduction process. The outermost shell, with its four valence electrons, is much less than half filled. Considering an individual atom alone, theory would predict that one or more of these four electrons might be readily broken away by thermal agitation or other relatively small forces. In the structure of germanium, however, the individual atoms are associated with each other in a

CHAPTER 3 AMPLIFIERS

crystalline lattice arrangement such that there is a definite bond between each atom and four immediately adjacent atoms. The structure is of course three-dimensional but the principle may be represented by the two-dimensional drawing of Figure 3-8. Two valence electrons - one from each atom - act together to form each bond, as represented by the two connecting lines between the atoms. In this configuration, the valence electrons are held in place much more strongly than they are by the attraction of the atom nucleus alone. In germanium, it requires some fourteen times as much energy to free an electron from a valence bond as it would to detach it from an isolated atom.

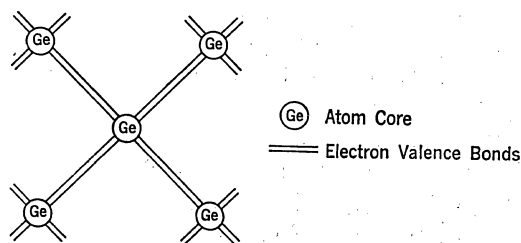

Figure 3-8 Valence Bond Structure of Germanium

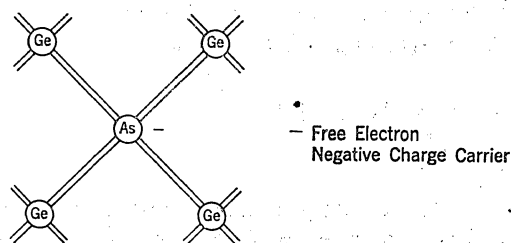

Figure 3-9 N-Type Germanium Structure

Nevertheless, some electrons are knocked out of their valence bonds by thermal agitation at normal room temperatures. These electrons are free to act as "charge carriers" and the electrical conductivity of the germanium depends upon their number. At higher temperatures, more electrons are broken from valence bonds and the conductivity of the semi-conductor increases proportionately. This relationship of conductivity to temperature readily accounts for the negative temperature-resistance characteristics of the semi-conductor devices known as thermistors, which are widely used in telephone work for automatic transmission regulation and other purposes.

Thermal agitation at normal temperatures does not provide enough charge carriers to make pure germanium capable of satisfactory transistor action. It is necessary for this purpose to modify the semi-conducting material so as to increase the number of carriers in roughly controllable amounts. This is done in two ways. In the first, pure germanium is "doped" with a small amount of an element with valence 5, such as arsenic (atomic number 33). Each arsenic atom will enter into the lattice structure in the manner indicated in Figure 3-9. Four of its outer-shell electrons join in valence bonds with four neighboring germanium atoms. The fifth valence

CHAPTER 3 AMPLIFIERS

electron is still associated with the arsenic atom but is quite easily dislodged. The net effect is to increase the number of free electrons in the material in proportion to the relative amount of arsenic added. In practical applications, this ratio is in the order of one impurity (arsenic) atom to 10 million germanium atoms. The semi-conducting material is now called n-type germanium because it contains a more than normal number of mobile negative charges.

Another way to increase the number of carriers is to dope the germanium with an element having valence 3, such as gallium (atomic number 31). As illustrated in Figure 3-10, the gallium atom also takes a position in the lattice structure. But its outer shell provides enough electrons to

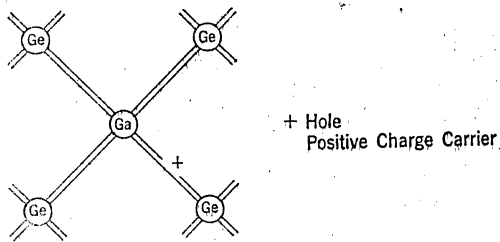

Figure 3-10 P-Type Germanium Structure

enter into valence bonds with only three of the germanium atoms, leaving one bond incomplete. The missing electron in the valence bond may be considered as a hole in the structure, which has an effective positive charge exactly equal but opposite to that of an electron. The hole may be filled by an electron which has been dislodged from another nearby valence bond by thermal agitation or other means. This process leaves a hole in the other bond so that the hole may be considered as having

moved from one point to another in the material. Thus, in net effect, the material now contains a substantial number of effective positive charges that are relatively free to move about in much the same way as free electrons may do. Such a material is called p-type because its mobile charge carriers are positive.

At first approach, the concept of holes as positive charge carriers may be regarded as a somewhat fanciful way of describing the transition of electrons from one valence bond to another. Actually, the electron in a valence bond is in a different "quantum state" than a valence electron in its ordinary position in the outer atomic shell of an isolated atom. In order to satisfactorily explain various observed conduction phenomena, it is not only convenient but necessary to treat the hole left by the ejection of an electron from a valence bond as if it were a real particle having mass, positive charge, energy, and velocity. This concept is reinforced by the observed fact that the mobility of positive and negative carriers is different. In germanium, electrons move, under a given electric potential, at somewhat more than twice the speed of holes (about 3600 cm per sec per volt per cm for electrons; about 1700 for holes).

CHAPTER 3 AMPLIFIERS

Whenever an electron escapes from the valence shell of an atom, the atom is left with a net positive charge. Such atoms are called donors and are present in relatively large numbers in n-type material. Similarly, when a hole escapes from a trivalent atom, the atom has a net negative charge because an extra electron has been added. These atoms, called acceptors, are common in p-type material. Both donors and acceptors are therefore ions (i. e., electrically charged atoms), but they are locked in position in the lattice structure of the material and can play no direct part in any conduction process. The conducting ability of the semi-conductor is thus due solely to the presence of free electrons and free holes, and is proportional to the sum of all such carriers - both positive and negative. In pure, or intrinsic, germanium at normal temperatures, the number of free electrons is equal to the number of holes because whenever an electron is released from a valence bond by thermal agitation, a hole is simultaneously created. Holes and electrons will of course be continuously neutralizing each other through new recombinations but a like number will be escaping from other valence bonds at the same time so that the net conductivity remains constant under static conditions. In n-type germanium, there are many more free electrons than holes. These are then designated the "majority carriers" but there will always be some holes present, too, as "minority carriers". The opposite situation prevails in p-type material, with holes now taking the role of majority carriers. Finally, it may be noted that the intrinsic material (pure germanium) will display certain n-type characteristics because, even though the number of holes and electrons is the same, the mobility of the electrons is appreciably greater than that of the holes.

Semi-Conductor Junctions

On the basis of the theory outlines above, it should not be surprising that a junction of semi-conducting materials of opposite types can constitute an excellent rectifier. When a battery, poled as indicated in Figure 3-11, is connected across such a junction, holes will be pulled out of the p-type material toward the right and electrons will be pulled out of the n-type

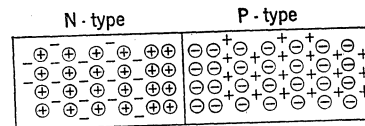
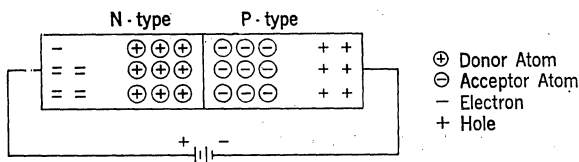

Figure 3-11 P-N Junction - Reverse Connection

Figure 3-12 Potential Barrier at P-N Junction

CHAPTER 3 AMPLIFIERS

material toward the left. There can then be no current flow, except that due to such relatively few minority carriers as may be present (holes in the n-type material, electrons in the p-type). When the applied voltage is in this reverse direction, there are practically no carriers at the junction which thus becomes an effective insulator. It is of interest to note, however, that the immobile donor and acceptor atoms remain, each of which has its own charge as illustrated in the drawing. Very high static electric fields may therefore exist, resulting in potential differences of considerable magnitude across the junction.

If the polarity of the battery is reversed, on the other hand, the forward direction of the applied voltage causes both holes and electrons to move toward the junction. Here they neutralize each other. The net result is a free flow of electrons in the external circuit which is limited only by the numbers of carriers in the semi-conducting materials. Depending on this factor and the physical size of the junction itself, n-p junction devices may be designed to transmit quite high currents in the forward direction and to give very high rectification ratios.

On the basis of the theory outlined above, it might be reasonable to assume that, in the absence of an external applied voltage, the electrons of the n-type material and the holes of the p-type material would gradually diffuse across the junction until the difference between the two semi-conductor types was entirely destroyed. As a matter of fact, this does not happen. When the junction is formed, it may be assumed that such diffusion of carriers across the junction starts. The carriers of opposite sign cancel each other out as they cross the junction, leaving on each side a layer of immobile charged atoms, as indicated in Figure 3-12. The electric fields set up by these fixed charges prevent further diffusion of the mobile carriers toward the junction. In other words, a potential barrier is automatically established across the junction between the two types of semi-conducting material, allowing each to maintain its own special characteristics. In the typical p-n junction, the magnitude of this potential barrier is in the order of tenths of a volt.

The Junction Transistor

The interesting behavior of the semi-conductor junction can be taken advantage of to produce another important electrical phenomenon known as the transistor effect. The device pictured in Figure 3-13 is a single crystal of germanium which has been doped in such a way as to consist of two blocks of n-type material separated by a thin slab of p-type semi-conductor. It thus includes two p-n junctions. Separate electrical connections may be made to the p-type section and to each of the n-type sections, as shown in the Figure. Now if we consider only the left junction (i. e., with the circuit opened at E_c) it will be noted that the battery E_e is poled in the forward direction to permit the ready flow of a substantial current I_e . Electrons move freely from the left n-material across the n-p junction into the p-material, and holes from the latter

CHAPTER 3 AMPLIFIERS

into the former. Considering only the right junction, on the other hand, the battery E_C is poled in the reverse direction so that practically no current can flow across the p-n junction.

When both battery circuits are closed, an entirely new effect appears. Under the influence of E_e , electrons from the left n-section move freely into the p-section as before. Here a few of them may be neutralized by holes. But if the p-section is made thin enough, most of the electrons will diffuse right across the p-section and be caught up by the field in the right n-section produced by battery E_C . The result is a current I_C flowing in the circuit through E_C , and practically no current flowing in the external connection to the p-type section. I_C may be almost, but never quite, equal in value to I_e . The ratio of I_C to I_e , which is usually designated by the Greek letter, α , ranges between .95 and .99 in typical junction transistors. The energy that drives I_C comes from E_C and E_e but the value of I_C is determined solely by I_e . This is the transistor effect, and its similarity to voltage phenomena in the three-electrode electron tube immediately suggests amplification possibilities.

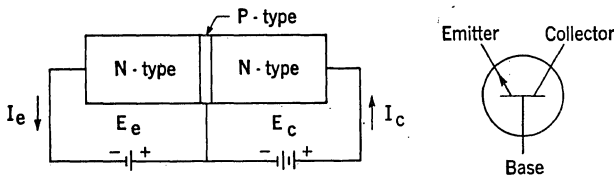

Figure 3-13 N-P-N Junction Transistor

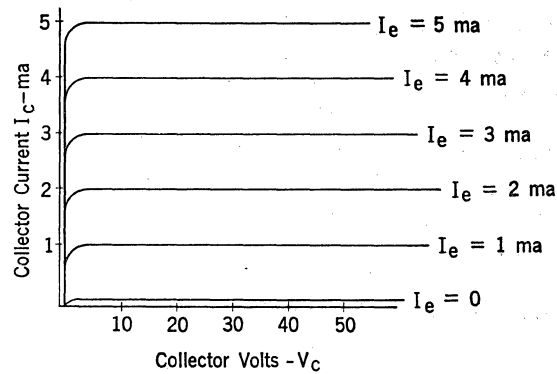

Figure 3-14 Collector Characteristics of N-P-N Junction Transistor

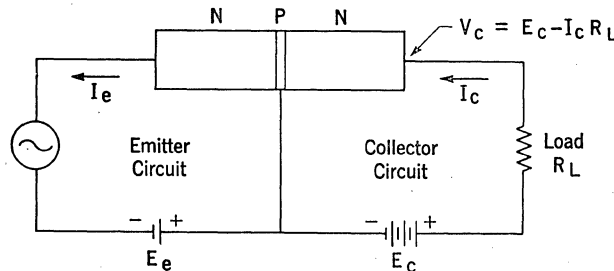

Figure 3-15 Common Base Amplifier Circuit

CHAPTER 3 AMPLIFIERS

In discussing the transistor further, it will be convenient to make use of certain nomenclature which has become standardized for historical reasons that will appear later. In the device of Figure 3-13, the n-type section at the left is called the emitter, the p-type section is the base, and the right n-section is the collector. The conventional schematic representation is shown at the right. Here, the emitter may be identified by the arrow head, which is pointed in the direction of conventional current flow - i. e., opposite to the direction of electron flow. It should also be noted that the arrows indicating the direction of current flow in the emitter and collector circuits of Figure 3-13 are also pointed in the conventional direction for current flow. This practice is followed throughout this text although in much of the earlier literature it has been the practice to point all such arrows toward the transistor elements regardless of the actual direction of current flow.

The amplifying capability of the transistor depends upon the fact, emphasized above, that the value of the collector current, I_C , is determined by the value of I_e . As long as the positive biasing voltage applied to the collector is large enough to maintain a positive field in the collector, nearly all of the electrons coming from the emitter will move into the collector and the current I_C will maintain a constant value slightly less than I_e . This is illustrated by Figure 3-14 which gives the collector characteristic curves of a typical n-p-n junction transistor for several values of I_e . Note that the collector voltage V_C indicated here is the potential applied to the collector and is not necessarily the same as the voltage of the biasing battery, E_C . A large load resistance may be inserted in the collector circuit without affecting the current value, even though the IR drop across the resistance approaches quite closely to the value of E_C . This means that, with an appropriate value of E_C , a small varying signal voltage introduced in the emitter circuit, as indicated in Figure 3-15, will produce corresponding voltage variations across the load of much greater magnitude. Very substantial voltage and power gains are thus readily attainable.

Junction transistors are also made with a p-n-p arrangement. Their characteristics are generally similar to those of the n-p-n transistor and the above discussion may be employed to explain their behavior by simply reversing the direction of current flow and the polarities of the biasing batteries, and substituting holes for electrons as the majority current carriers. It should be noted that the emitter current of the p-n-p transistor will also flow in the opposite direction and this will be indicated in the conventional diagram by pointing the emitter arrow head toward the base instead of away from it as in the n-p-n case.

Whichever type of transistor is being dealt with, it is imperative to keep in mind that the emitter must always be biased in the forward direction and the collector in the reverse direction. Application of biasing

CHAPTER 3 AMPLIFIERS

potentials not poled in accordance with this basic principle may destroy the transistor.

Electron Tube - Transistor Analogy

Succeeding sections discuss circuit applications using electron tubes, however, companion transistor circuits can be visualized by drawing a very rough analogy between the electron tube and the transistor. In the analogy, grid, cathode and plate of the tube are replaced by base, emitter and collector of the transistor respectively. Grounded-grid, grounded-cathode, and grounded-plate circuit configurations become grounded-base, grounded-emitter and grounded collector as shown in Figure 3-16.

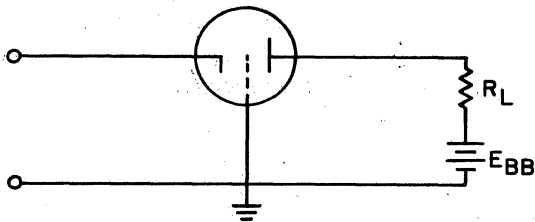

GROUNDING GRID

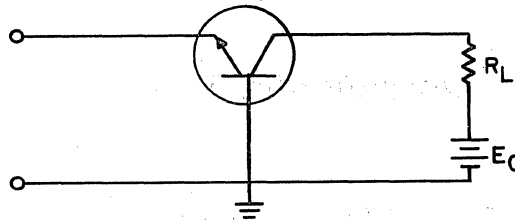

GROUNDING BASE

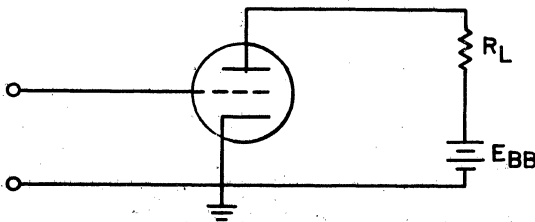

GROUNDING CATHODE

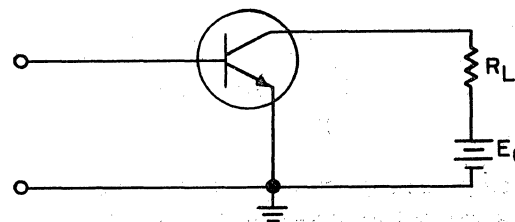

GROUNDING EMITTER

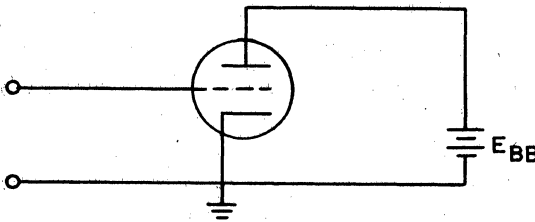

GROUNDING PLATE

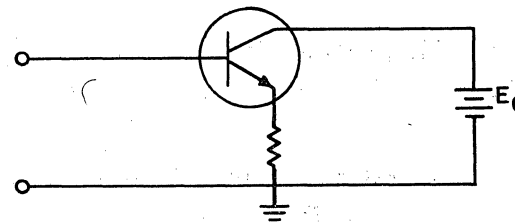

GROUNDING COLLECTOR

Figure 3-16 - Electron Tube-Transistor Analogy

3.4 AMPLIFICATION

The Triode Amplifier

The triode as a circuit element has three important characteristics: the amplification factor, the plate resistance and the mutual conductance. The amplification factor can be shown to be numerically equal to the product of the plate resistance and the mutual conductance.

The amplification factor expresses the effectiveness of the grid as a control agent, compared to the effectiveness of the plate. Amplification factor is the ratio between a small plate voltage change and a grid voltage change which would produce an effect on the plate current of equal magnitude. The signs are opposite, for the grid must restore the change made by the plate if plate current is to remain unchanged during the measurement.

$$\text{Amplification Factor } \mu = - \frac{de}{de} \frac{p}{g} \quad \text{where } i \text{ is constant,}$$

and de = small change in plate voltage
 p

de = small change in grid voltage
 g

i = plate current
 p

The plate resistance, or more properly the dynamic plate resistance of a tube is somewhat analogous to the internal resistance of a generator. It is defined as the ratio between a small plate voltage change and the corresponding plate current change (with grid voltage held constant).

$$\text{Plate Resistance, } r = \frac{de}{di} \frac{p}{p} \quad \text{where } e \text{ is constant}$$

and di = small change in plate current
 p

Figure 3-17 shows a plot of triode plate characteristic curves and demonstrates the graphical method to find dynamic plate resistance for a certain operating point on one of the curves. It will be seen that the plate resistance is the inverse slope of the plate characteristic curve at the operating point.

CHAPTER 3 AMPLIFIERS

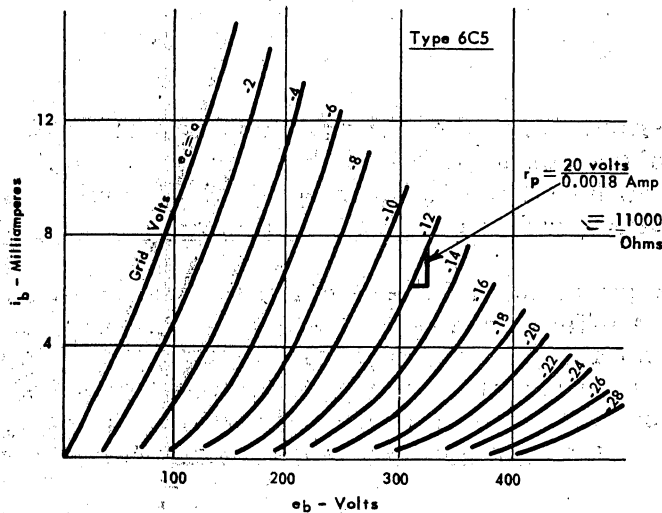

Figure 3-17 Triode Plate Characteristics

The mutual conductance of a triode is the ratio of a small change in plate current to the small change in grid voltage which produces it, plate voltage remaining constant.

$$\text{Mutual Conductance, } g_m = \frac{di_p}{de_c} \text{ where } e_b \text{ is constant}$$

Figure 3-18 shows a plot of triode grid characteristic curves and demonstrates the graphical method to find mutual conductance for a certain operating point on one of the curves. It will be seen that the mutual conductance is the slope of the grid characteristic curve at the operating point.

Figure 3-3 shows the actual connection of a triode amplifier. R_L is the plate load resistor and e_L is the voltage across the load. E_{bb} is the plate battery voltage and E_{cc} is the grid battery voltage. Figure 3-19 shows a simple equivalent circuit from which the performance of the amplifier is readily computed. From the equivalent circuit, Figure 3-19 it can be seen that the plate current is:

$$i_p = \frac{\mu_e g_m}{r_p + R_L}$$

and the useful amplification, $\frac{e_o}{e_i}$ is:

$$\text{Amplification} = \frac{\mu R_L}{(r_p + R_L)}$$

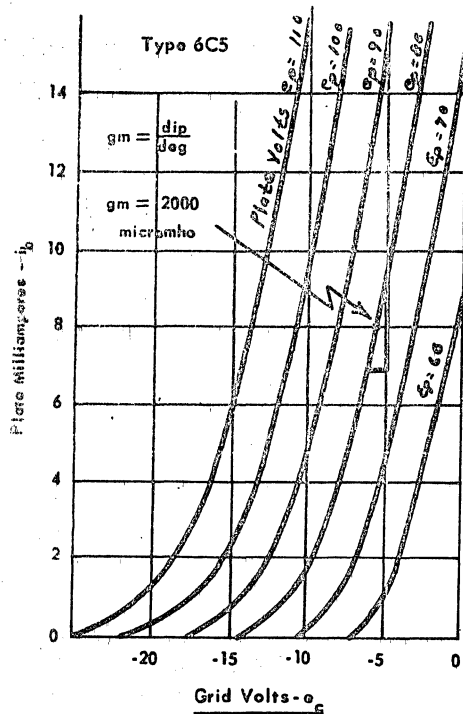

Figure 3-18 Triode Grid Characteristics

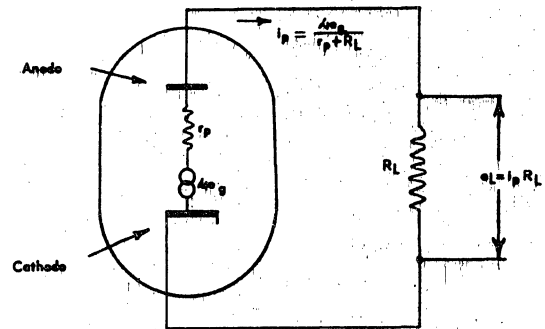

Figure 3-19 Triode Amplifier - Equivalent Circuit

Multi-stage Amplifiers - Coupling

To obtain large power output from a small voltage source, it is necessary to use several stages of amplification with the output of one stage feeding the input of the next. Transformer coupling is sometimes used in multi-stage audio amplifiers. The transformer provides a simple method to isolate the dc plate voltage from the grid of the following tube. The alternating (signal) voltage on the plate is reproduced in the secondary transformer winding and the voltage may be stepped up by providing more turns on the secondary than on the primary winding. The transformer may also be designed to match a low-impedance load to a high-impedance source. Figure 3-20 shows two stages of an amplifier with transformer coupling.

CHAPTER 3 AMPLIFIERS

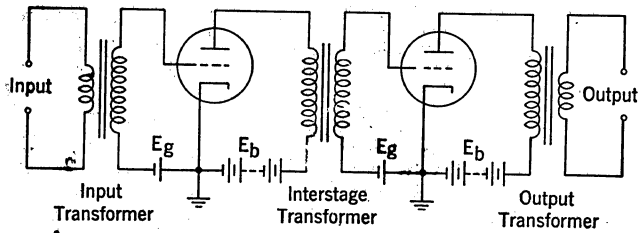

Figure 3-20 Transformer-Coupled Amplifier

Resistance-capacitance coupling is another widely used method to connect amplifier stages. Resistance-capacitance coupled amplifiers are relatively cheap and have good fidelity over comparatively wide frequency ranges. Figure 3-21 shows an RC-coupled triode amplifier and gives the names of the circuit elements.

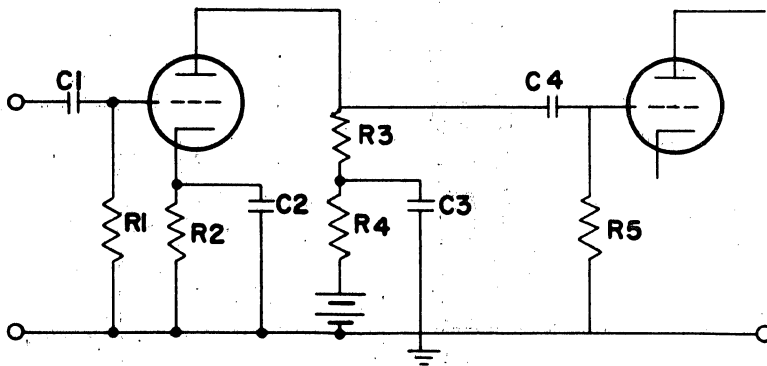

Figure 3-21 RC-Coupled Amplifier

- R1 Grid-Leak Resistor
- R2 Cathode Bias Resistor
- R3 Plate Load Resistor
- R4 Plate Decoupling Resistor
- R5 Second stage Grid Resistor
- C1 Input Coupling Capacitor
- C2 Cathode Bypass Capacitor
- C3 Plate Supply Bypass Capacitor
- C4 Output Coupling Capacitor

Impedance coupling is obtained by replacing the load resistor of an RC-coupled amplifier with an inductance. See Figure 3-22. An impedance-coupled amplifier can be designed to give fairly uniform frequency response over a limited frequency range. In such case the amplification is greater than for a similar RC-coupled amplifier.

In a direct-coupled amplifier, the plate of one tube is connected directly to the grid of the next tube. With direct coupling, it is necessary to provide separate power supplies for each stage or to use a special voltage-divider. Figure 3-14 shows direct coupling with a voltage divider network.

Band Width Requirements

An important characteristic of an amplifier is its band width. In general, the greater the band width the less the gain which may be obtained. Single-frequency amplifiers are used to amplify carriers or signalling tones. Audio amplifiers may have band width requirements of 5,000 to 15,000 cycles. Video amplifiers must have band width of several megacycles.

CHAPTER 3 AMPLIFIERS

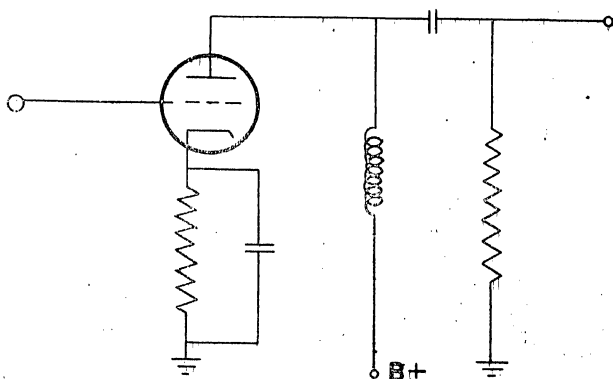

Figure 3-22 Impedance-Coupled Amplifier

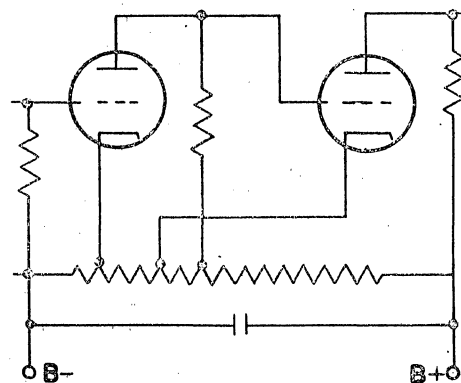

Figure 3-23 Direct-Coupled Amplifier

Class A, B, C, Amplifiers

Amplifiers are classed according to the method of operation. The dc grid bias and the input signal of an oscillator may be adjusted so that plate current flows at all times or so that plate current flows only during part of each cycle of the signal.

A Class A amplifier is one in which plate current flows at all times.

A Class B amplifier is one in which grid bias is adjusted so that plate current is approximately zero in the absence of a signal and plate current flows for approximately one-half of each cycle when a signal is applied.

A Class C amplifier is one in which the grid is adjusted appreciably beyond the cutoff value, so that plate current flows for appreciably less than half of each cycle when a signal is applied.

Class A amplifier give faithful reproduction of the input signal and are widely used for audio amplification and modulated carrier amplification. Class B amplifiers when used for audio amplification must be used in push-pull. Class C amplifiers can be used only for unmodulated rf waves.

3.5 TRANSFORMER COUPLED AMPLIFIERS

The transformer coupled amplifier has limitations with respect to the frequency bandwidth that it can handle on a "flat" basis. This is due to the inductance of the transformer windings, and to their effective shunt capacitance. At frequencies below about 100 cycles per second, the inductive reactance of the primary winding of the inter-stage transformer is low enough in value so that the output resistance of the tube is not negligible in comparison with it. This results in a relative decrease in the voltage

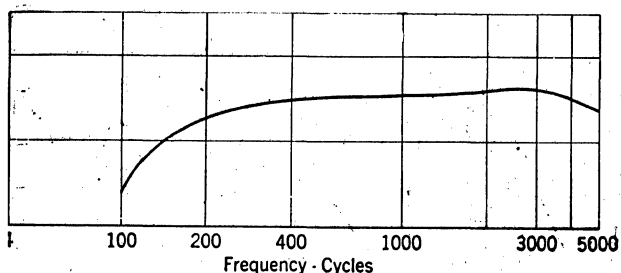

Figure 3-24 Gain-Frequency Characteristic of Audio Amplifier

across the primary winding, and a consequent reduction in amplification. At frequencies above 4,000 cycles, the shunt capacitance becomes increasingly important. Since capacitive reactance is inversely proportional to frequency, the complex impedance of the transformer input becomes lower at the higher frequencies, with a consequent lower voltage across the primary winding. There is also a tendency to develop a resonance effect between the shunt capacitance and the inductance, which may produce a definite hump in the frequency-gain curve near the higher frequency end. Well constructed amplifiers of this type, however, have a reasonably flat frequency response over a range from a little above 100 to approximately 5,000 cycles. This is illustrated by the curve of Figure 3-24.

3.6 RESISTANCE-CAPACITANCE COUPLED AMPLIFIERS

Where flat frequency response over a greater range than four or five thousand cycles is required, resistance-capacitance coupling is commonly employed. An amplifier circuit of this type is shown schematically in Figure 3-25. Here, the a-c input is through the input capacitor C_i to a grid resistance R_g , the drop across which is applied to the grid of the first tube. Grid bias is provided by the drop across the cathode resistor R_k , through which the d-c component of the plate current flows. The a-c component of the plate current is by-passed by the capacitor C_k so that it has no effect on the grid. The alternating voltage drop across the resistor R_L is coupled to the input of the second tube by the capacitor C_c , which also prevents the plate battery voltage E_b from being impressed on the grid of the second tube.

An equivalent circuit for one stage of the R-C amplifier is shown in Figure 3-26. Here two shunting capacitors are indicated, which did not appear in Figure 3-27.

C_{out} represents the inter-electrode capacitance of the first tube - chiefly the plate to cathode capacitance, C_{pk} - together with such shunt capacitances as may be introduced by the circuit wiring. C_{in} represents a comparable capacitance C_{gk} at the input of the second tube. In a mid-frequency range - from about 100 to somewhat more than 10,000 cycles - the effect of the inter-electrode capacitances of the tubes is so small that the shunting capacitors C_{out} and C_{in} may be neglected. In this same frequency

CHAPTER 3 AMPLIFIERS

range, the coupling capacitor C_c may be considered as an a-c short-circuit because its reactance is negligible. The equivalent circuit then reduces to the parallel combination of resistors R_L and R_g across the tube output, as indicated in Figure 3-27. In the low frequency range, however, (below 100 cycles) the coupling capacitor C_c can no longer be ignored. Its reactance now becomes great enough that the voltage across R_L is divided between C_c and R_g with an increasing amount appearing across C_c , and a decreasing amount appearing across R_g . The input to the second tube is accordingly decreased, and the gain of the amplifier falls off. In the high frequency range (above 10,000 cycles), on the other hand, the effect of the coupling capacitor C_c again becomes negligible, but the net reactance of the shunting capacitors, C_{out} and C_{in} , then becomes small enough to cause the output voltage to fall off.

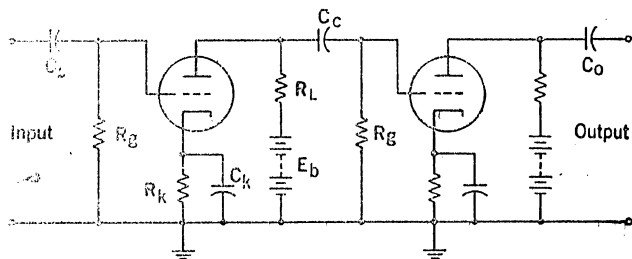

Figure 3-25 Resistance-Capacitance Coupled Amplifier

to the second tube is accordingly decreased, and the gain of the amplifier falls off. In the high frequency range (above 10,000 cycles), on the other hand, the effect of the coupling capacitor C_c again becomes negligible, but the net reactance of the shunting capacitors, C_{out} and C_{in} , then becomes small enough to cause the output voltage to fall off.

It will be clear that the bandwidth of reasonably flat frequency response of the R-C coupled amplifier depends mainly upon the values of C_c , R_L and R_g , and the values of the tube inter-electrode capacitances. Amplifiers with a flat response over a range of 50 to some 15,000 cycles may be readily designed without employing extraordinary methods. Where broader response is required, rather extreme capacitance and resistance values may be required for some of the elements of the interstage coupling networks. Inductors and additional capacitors may also be added to the

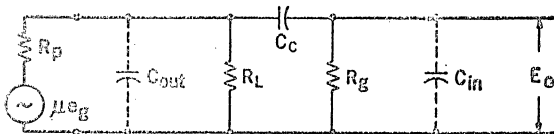

Figure 3-26 Equivalent Circuit of Single Stage of R-C Coupled Amplifier

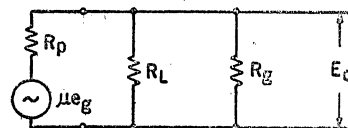

Figure 3-27

network in various connections that will help to extend the transmitted band to both lower and higher frequencies. Tubes specially designed to have minimum grid to plate capacitance (or maximum transconductance) may also be necessary. Such tubes will ordinarily be pentodes or tetrodes which have much lower grid-plate capacitance than triodes and much higher transconductance and plate resistance.

CHAPTER 3 AMPLIFIERS

The more elaborate interstage networks employed in broad-band amplifiers naturally tend to reduce the gain that can be obtained in each stage and thus may require the use of more stages for a given overall amplification. The range of uniform frequency response can be extended through several million cycles, however, with types of tubes now available and proper design of the coupling networks. In communications work, perhaps the most severe practical requirement occurs in the case of the so-called "video" amplifier, which, ideally, should give a flat response over the total range from zero to about four million cycles.

3.7 RADIO-FREQUENCY AMPLIFIERS

Voltage amplifiers for most of the applications in radio circuits, such as radio receivers and the low-power stages of radio transmitters, do not have to meet as severe requirements with respect to frequency response as do audio or video amplifiers. This is because the typical radio circuit is designed in theory to handle only the single frequency to which it is tuned. Actually, of course, the tuning is not so sharp that it does not permit the passage of a band of frequencies extending far enough on both sides of the tuned frequency to carry the complete communication signal. Coupling between the stages of radio amplifiers is commonly accomplished by means of single air-core transformers. As indicated in Figure 3-28, one or both windings of the coupling transformer are tuned with a parallel capacitor to the signal frequency. Where both primary and secondary are so tuned, a good band of frequency response with sharp cutoff at each end is readily obtained. The transformer itself need have little or no voltage gain because tubes with high amplification factors are used.

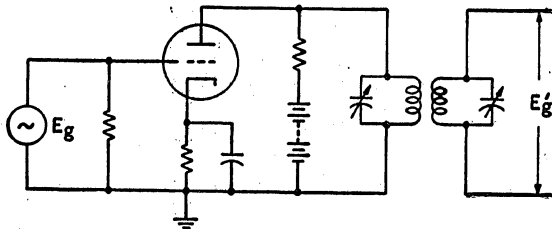

Figure 3-28 Radio Amplifier Circuit

3.8 NEGATIVE-FEEDBACK AMPLIFIERS

For a great majority of amplifier applications in telephone work, it is important not only that the output signal be a faithful reproduction of the input signal, but also that maximum stability of amplifier operation be secured. Both of these objectives can be met to a very large degree by feeding back some of the amplifier output to the input circuit in an inverse phase relationship. An amplifier so connected is called a negative

CHAPTER 3 AMPLIFIERS

feedback or degenerative amplifier. Its principle may be understood by referring to Figure 3-29. In this Figure, (A) indicates an amplifier without feedback, having an overall voltage amplification or gain of A . In Figure 3-29 (B), a part of the output voltage is returned to the input, 180° out of phase with the input voltage, through a feedback circuit having a loss β . Without feedback Figure 3-29 (a) we have -

$$E_o = AE_i = AE_g \quad (3:1)$$

In Figure 3-29 (B), on the other hand, the actual input voltage E_g of the amplifier unit is no longer equal to E_i , but to the sum of this voltage and the feedback voltage E_o . That is -

$$E_g = E_i + \beta E_o \quad (3:2)$$

The output voltage therefore is -

$$E_o = AE_g = A(E_i + \beta E_o)$$

Solution of this equation for the overall voltage gain, E_o/E_i , gives -

$$\frac{E_o}{E_i} = \frac{A}{1 - \beta A} \quad (3:3)$$

Since the feedback is inverse (negative), the value of βA is negative and the denominator of equation (3:3) is greater than unity. Negative feedback accordingly always reduces the net gain, but the reduction can be compensated by the use of an amplifier having as high gain A as may be required to obtain the desired overall gain. When the product βA is much larger than unity, as is the case in most practical circuits, the overall amplification becomes effectively -

$$\text{Net Amplification} = - \frac{1}{\beta} \quad (3:4)$$

In other words, the effective gain of the circuit depends entirely upon the characteristics of the feedback circuit. This may perhaps be better understood by considering a numerical example. In the circuit of Figure 3-30, the gain A of the amplifier unit is 80 db (voltage ratio of input to output of 1 to 10,000) and the loss in the feedback circuit is 60 db (voltage ratio of 1,000 to 1). From equations (3:2) and (3:3) -

$$E_g = E_i \left(\frac{1}{1 - \beta A} \right) \quad (3:5)$$

CHAPTER 3 AMPLIFIERS

If the applied input voltage E_i is 1 millivolt, the actual input voltage to the amplifying unit is therefore -

$$E_g = \frac{1}{1 - \frac{10,000}{-1,000}} = \frac{1}{1 - (-10)} = \frac{1}{11}$$

$$= .09091 \text{ millivolt}$$

The output voltage is -

$$AE_g = E_o = 10,000 \times .09091 = 909.1 \text{ millivolts}$$

This output of 909.1 millivolts is also impressed on the feedback circuit which allows 1/1000 of it to be fed back to the amplifier input. In passing through the feedback circuit its phase is shifted until it is out of phase with the applied input of 1 millivolt, which gives it a minus sign. We then have - .9091 millivolt combining with the initial 1 millivolt to give the actual input voltage to the amplifier, which, therefore, is -

$$1.000 - .9091 = .0909 \text{ millivolt}$$

This checks the value of E_g obtained above, which means that the amplifier is stable and as long as the applied input of 1 millivolt is maintained, there will be 909.1 millivolts in the output. The overall gain of the amplifier under these conditions is -

$$20 \log_{10} \frac{\text{Output voltage}}{\text{Input voltage}} = 20 \log_{10} \frac{909.1}{1}$$

$$= 20 \times 2.9586 = 59.17 \text{ db}$$

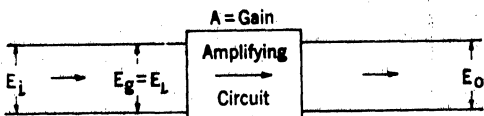

a. Amplifier without Feedback

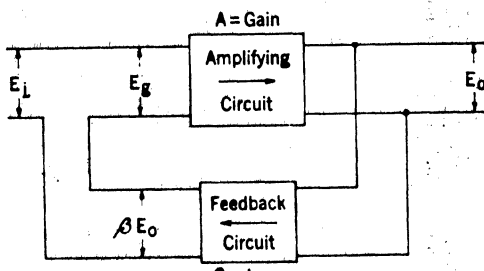

b. Amplifier with Feedback

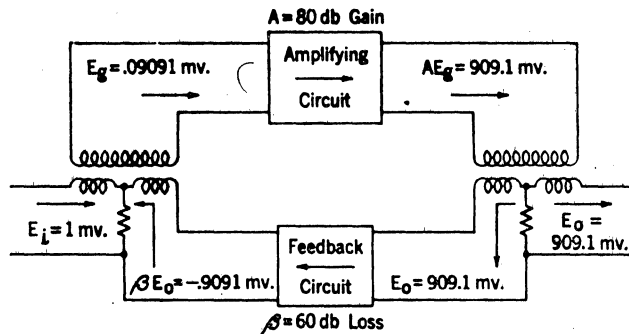

Figure 3-30 Example of Negative Feedback Circuit

Figure 3-29 Principle of Negative Feedback

CHAPTER 3 AMPLIFIERS

It will be noted that for all practical purposes this gain is the same as the loss of the feedback circuit.

If we had used an amplifier unit with a higher gain - say 100 db (voltage ratio of input to output of 1 to 100,000) - and the same loss in the feedback circuit, we might expect the output voltage to be much higher, but such is not the case. Using equation (3:5) again we find the actual input voltage now is -

$$E_g = \frac{1}{1 - \frac{100,000}{-1,000}} = \frac{1}{101} = .009901 \text{ millivolt}$$

The output voltage, E_o , accordingly is -

$$100,000 \times .009901 = 990.1 \text{ millivolts}$$

and overall gain of the amplifier is -

$$20 \log_{10} \frac{990.1}{1} = 20 \times 2.9957 = 59.91 \text{ db}$$

which is again practically equal to the loss in the feedback circuit. This means that even if the gain A of the amplifier unit changes due to variations in the battery supply, changing tube characteristics, etc., the overall gain remains the same for all practical purposes.

Another important feature of the negative feedback amplifier is its ability automatically to reduce to a negligible magnitude any noise or harmonic distortion developed within the amplifier itself. This is true because a part of this noise and distortion appearing in the output is fed back to the input through the feedback circuit where it re-enters the amplifier in such a phase relation that when it is amplified and again appears in the output, it is out of phase with the original noise and distortion, thereby reducing its effect. Feedback circuits may be designed with either voltage feedback or current feedback. Figure 3-31 illustrates a simple voltage feedback arrangement. Here the total resistance ($R_1 + R_2$) of the voltage

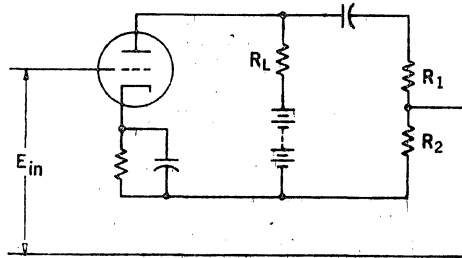

Figure 3-31 Voltage Feedback Circuit

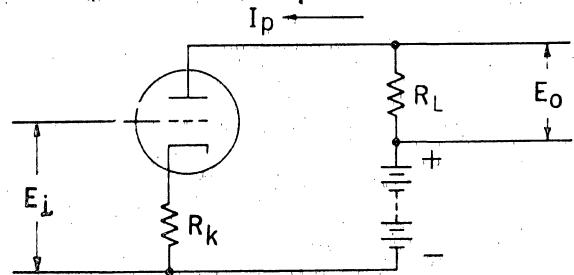

Figure 3-32 Current Feedback Circuit

CHAPTER 3 AMPLIFIERS

divider is made large enough so that its shunting effect on the load resistance R_L is practically negligible. The magnitude of the feedback factor β is -

$$\beta = \frac{R_2}{R_1 + R_2}$$

and the overall gain when A is large compared to unity is the reciprocal of this -

$$\text{Net gain} = \frac{R_1 + R_2}{R_2} \quad (3:6)$$

The voltage fed back is 180° out of phase with the alternating input voltage because it represents a voltage drop in the plate circuit, and the plate current is in phase with the input voltage.

The simplest type of current feedback arrangement may be obtained by the use of an unbypassed cathode resistor, as indicated in Figure 3-32. Here the alternating plate current I_p must flow through R_k as well as through the load R_L . This causes a voltage drop across the cathode resistor equal to $I_p R_k$, and the net input voltage applied to the grid is then -

$$E_g = E_i - I_p R_k$$

This may be rewritten in terms of E as follows -

$$E_g = E_i + \frac{E_o R_k}{R_L}$$

since E_o is equal to $-I_p R_L$, the drop across the load resistance. Comparison of this equation with (3:2) shows that $\beta = R_k/R_L$; and when βA is large compared to unity -

$$\text{Net gain} = \frac{R_L}{R_k}$$

3.9 THE CATHODE-FOLLOWER

An interesting example of maximum application of negative feedback is displayed in the so-called cathode-follower circuit, shown in Figure 3-33. Here there is one hundred percent current feedback through the cathode resistor, R_k - in other words, β is equal to unity. The output is taken across the cathode resistor so that the input and output voltages are

CHAPTER 3 AMPLIFIERS

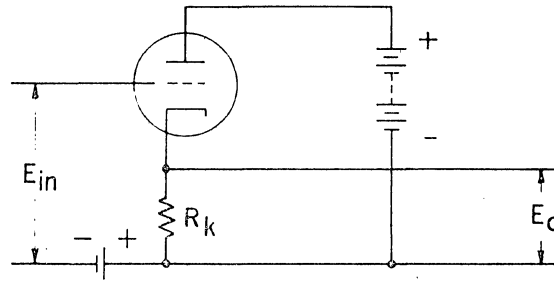

Figure 3-33 Cathode Follower Circuit

necessarily in phase and the a-c cathode to ground voltage varies in the same direction or "follows" the applied grid to ground voltage. The net voltage gain of the circuit is always less than unity because of the hundred percent negative feedback. It may be expressed as -

$$\text{Net gain} = \frac{\mu R_k}{R_p + R_k (1 + \mu)}$$

where μ is the amplification factor of the tube and R_p is its plate resistance.

As an amplifier, the cathode-follower circuit would appear useless since its voltage gain is less than one. However, it is still capable of delivering power to a load without requiring appreciable input power, and with extremely faithful reproduction of the variations in the input voltage. The circuit is very stable and virtually independent of any variation in the tube characteristics. These factors make it useful as a stabilizing coupling circuit between an amplifier and a load. More important is the fact that while the input impedance of the circuit is high, its output impedance is very low for an amplifier. This output impedance consists of R_k in parallel with an effective plate resistance equal to $R_p / (1 + \mu)$. Since the value of $R_p / (1 + \mu)$ is less than 1,000 ohms for most tubes, the value of the net output impedance must be still less. As an impedance-matching device accordingly, the cathode-follower circuit is useful for such purposes as coupling the relatively high impedance output of a video amplifier to the low impedance of a coaxial line.

3.10 POWER AMPLIFIERS

The classification of amplifier circuits as between voltage amplifiers and power amplifiers is not very definite. Actually, the term "power amplifier" is somewhat misleading because it is perfectly possible for an amplifier to deliver a substantial power output without appreciable power input. The power classification is applied generally in practice to situations where the delivery of a desired amount of power is the controlling

CHAPTER 3 AMPLIFIERS

criterion, and voltage gain, if any, is of secondary importance. Thus, an amplifier used to drive a load such as a loudspeaker or other device requiring considerable power for its operation, is ordinarily classed as a power amplifier. So is the amplifier that must supply many kilowatts of power to drive the antenna of a radio transmitter.

The power that a vacuum tube amplifier can develop of course depends generally on the maximum value of current that may flow in its plate circuit. In most audio amplifier applications, this value is limited by

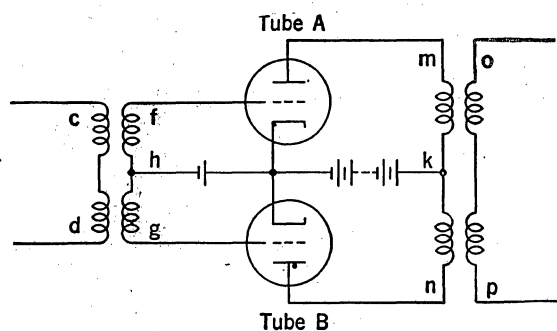

Figure 3-34 Push-Pull Amplifier

the fact that the tube must operate on the straight line portion of its characteristic curve in order that its output be a faithful reproduction of the input signal. The maximum power that can be delivered, therefore, depends upon the size and characteristics of the tube or tubes used. Where the power requirement is a matter of a very few watts, as for driving the speaker of an ordinary radio receiver, a single triode or pentode may be used. Such a tube is not different in appearance from the tubes used in voltage amplifying circuits, although its design characteristics will generally be such that it will have a lesser amplification factor and a larger plate current.

Push Pull Amplifier

Where more power than a single tube can deliver is required, together with maximum fidelity of signal reproduction, two tubes may be employed in a "push-pull" circuit, as shown in Figure 3-34. In this circuit, the two tubes, A and B, have identical characteristics. An alternating voltage applied at the input, cd, impresses voltages of equal magnitude but opposite polarity upon the control grids of tubes A and B. As the control grid of one tube becomes less negative (more positive), its plate current increases; at the same time, the control grid of the other tube becomes equally more negative, which decreases its plate current; and vice versa. Since the plate battery is connected to the midpoint, k, of the primary winding, mn, of the output transformer, the plate currents flow in opposite directions in each half of the primary winding. When the two plate

CHAPTER 3 AMPLIFIERS

currents are equal, therefore, there is no current in the secondary winding, op. On the other hand, a decreasing plate current in one half of the primary winding, and an increasing plate current in the other half, induce equal currents in the same direction in the secondary winding, op. The total output is thus obviously equal to the sum of the outputs of the two tubes.

As a matter of fact, the push-pull circuit will provide a power output appreciably greater than twice the output of an amplifier employing only one tube. This is due to the fact that the tubes of the push-pull amplifier may be given more control grid bias than a single tube without causing distortion in the output. The characteristic curve of a triode is of such shape that its output, when working over a portion of the curve including some curvature, consists principally of the fundamental or desired frequency, and its second harmonic (double the fundamental frequency). Such outputs are illustrated in Figure 3-35 (A) and (B) where it will be noted that the net output of each tube, represented by the heavy lines, is considerably distorted. It may also be noted, however, that the second harmonics in the outputs of both tubes become positive and negative at the same time. This means that the components of the current represented by these harmonics are always flowing in opposite directions in the halves of the primary winding, mkn, and accordingly produce no effect in the secondary winding, O-P. In other words, the second harmonics cancel each other. The net result is indicated in Figure 3-25 (C), where the two output currents are shown to add to produce a sine wave, which is a faithful reproduction of the input signal. Because the push-pull amplifier can thus be operated over a greater range of its tubes' characteristic curves, its output may actually exceed by more than three times the equally distortionless output that could be obtained from a single tube amplifier.

All of the amplifiers that have been considered thus far have operated on a high fidelity basis - i. e., so that the output signal presents a faithful reproduction of the input signal. In radio parlance, such operation is designated "Class A", a term which indicates, in general, that the amplifier tubes are operating only on a straight line portion of their characteristic curves. All Class A amplifiers have comparatively low "plate efficiency" - that is, the ratio of their useful output power to the total power supplied to the plate circuit by the B battery cannot be greater than 50% in theory, and is usually not much higher than 25% in practice. In audio amplifiers, where the output power is in any event not very great, this is not too important. In high-powered radio transmitters, on the other hand, where output power is measured in kilowatts, better efficiency becomes economically significant, and leads to the use when possible of "Class B" and "Class C" operation. The grids of Class B amplifiers are biased to the cutoff point so that plate current flows only during one-half of the cycles of an applied alternating voltage. In Class C

CHAPTER 3 AMPLIFIERS

operation, the grid is biased well beyond the cutoff point so that plate current flows during less than one-half of each cycle of applied grid voltage. The effective results are indicated in Figure 3-36 (A) and (B) respectively. It is evident that in both cases, the output wave form presents a highly distorted version of the wave form of the input signal. However, plate current flows and draws power from the B supply only part of the time as contrasted with the continuous power drain in Class A operation. The plate efficiency of these types of amplifiers is therefore higher, having a theoretical possible maximum of 78% in the case of Class B operation, and as much as 85% in Class C operation.

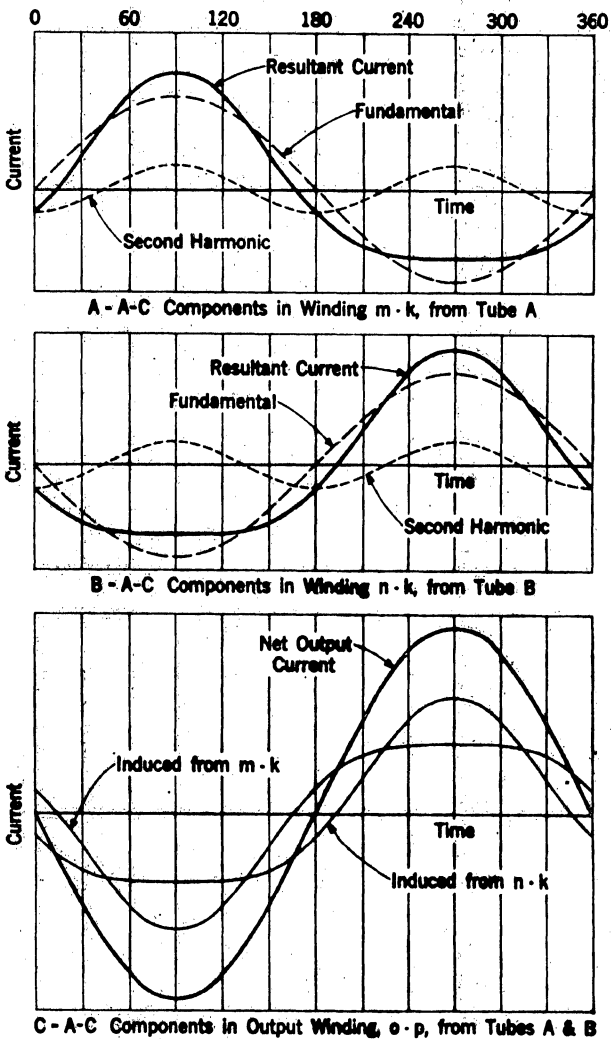

Figure 3-35 Principle of Push-Pull Amplifier

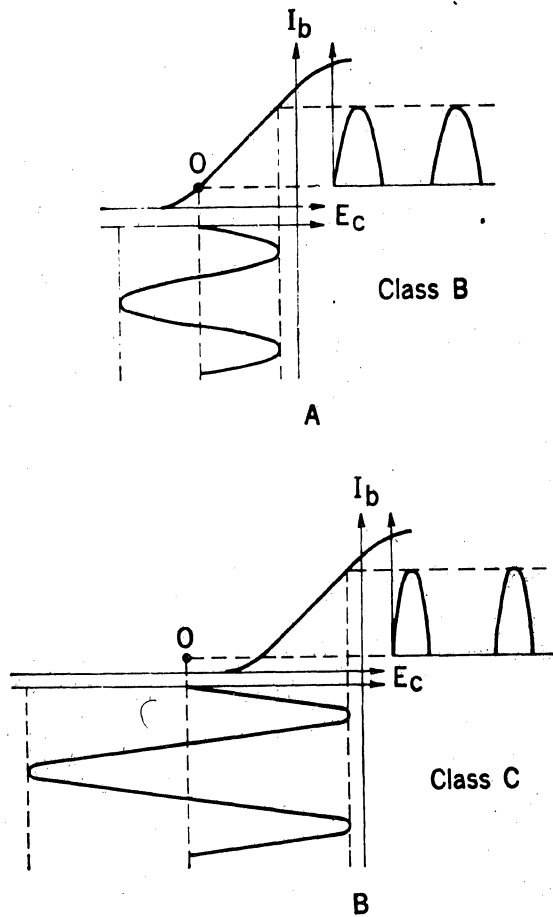

Figure 3-36 Operating Characteristic of Class B and C Amplifiers

CHAPTER 3 AMPLIFIERS

Radio power amplifiers ordinarily work into a load impedance which includes a parallel-tuned circuit, as indicated in Figure 3-37. This L-C tank circuit, when tuned to the operating frequency, acts as a filter to suppress the many harmonics of the fundamental frequency that must obviously be present in the plate circuit of a tube operating Class B or C. The current flowing in the load itself consequently represents only the fundamental input frequency. Its amplitude, however, cannot be expected to be linearly related to the input voltage. In Class B operation, distortion may be held to reasonable proportions by operating two tubes in a push-pull arrangement. In this case, one tube will provide an approximately true reproduction of the positive half of the input voltage wave, while the other tube furnishes a like reproduction of the negative half of the input wave. The net effect is illustrated graphically in Figure 3-38.

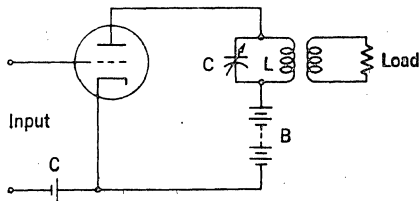

Figure 3-37 R-F Power Amplifier

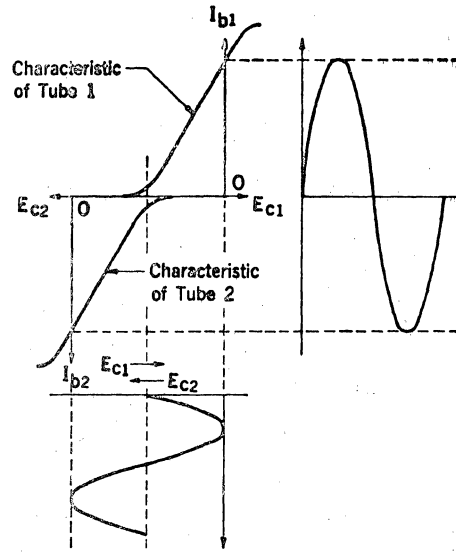

Figure 3-38 Graphical Representation of Class B Push-Pull Amplifier Operation

3.11 CARRIER AMPLIFIERS

The several types of carrier systems currently in use in telephone practice employ frequency bands ranging from 4,000 cycles up to as high as several million cycles. The amplifiers used in these systems must be designed to handle the entire frequency band of each particular system on a high fidelity basis with a reasonably flat gain over the total frequency range. All such amplifiers are designed with stabilized feedback circuits.

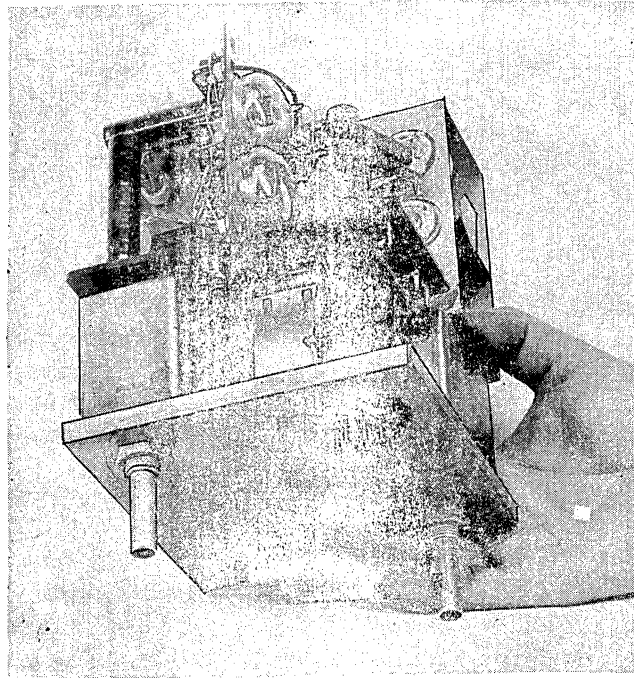
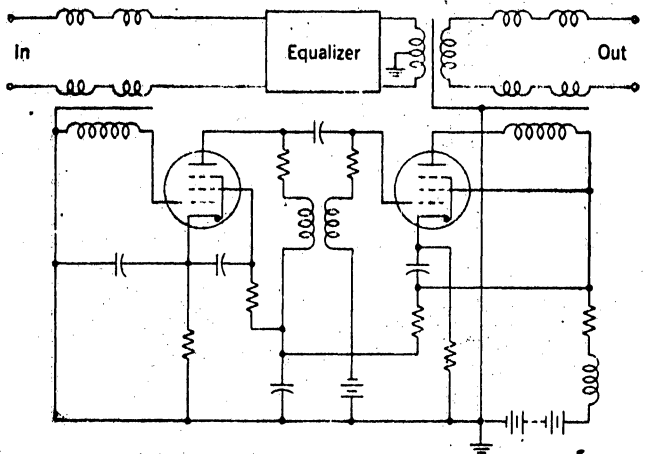

Figure 3-39 Telephone Repeater
Used in Type-C Carrier System

Type L1 Carrier
Amplifier

Figure 3-39 is a schematic of an amplifier used in the type-C carrier system which operates over the frequency range from 5 to 35 kc. As indicated, it consists of two transformer-coupled pentodes with hybrid type input and output transformers. The negative feedback circuit is connected between the two hybrids through an equalizer network circuit. This amplifier has a gain of 50 db, flat from 5 to 35 kc.

Amplifiers for the type-J and type-K carrier systems must handle still broader frequency bands. Thus the type-J amplifier must operate through a range of 36 to 140 kc. It is a three stage amplifier using voltage amplifying pentodes in the first two stages and four power pentodes in parallel in the last stage. Resistance-capacitance coupling is used in the inter-stage networks. The amplifier has two feedback circuits. The outer feedback circuit extends from the output to the input hybrid transformer through an equalizer network. An auxiliary inner feedback path is connected from the parallel plates of the output tubes to the grid of the input tube through a network which is designed to control the singing margin at frequencies considerably above the normally transmitted band. Type-K carrier amplifiers (12 to 56 kc) also employ three stages, with feedback through a gain adjusting and equalizing network.

CHAPTER 3 AMPLIFIERS

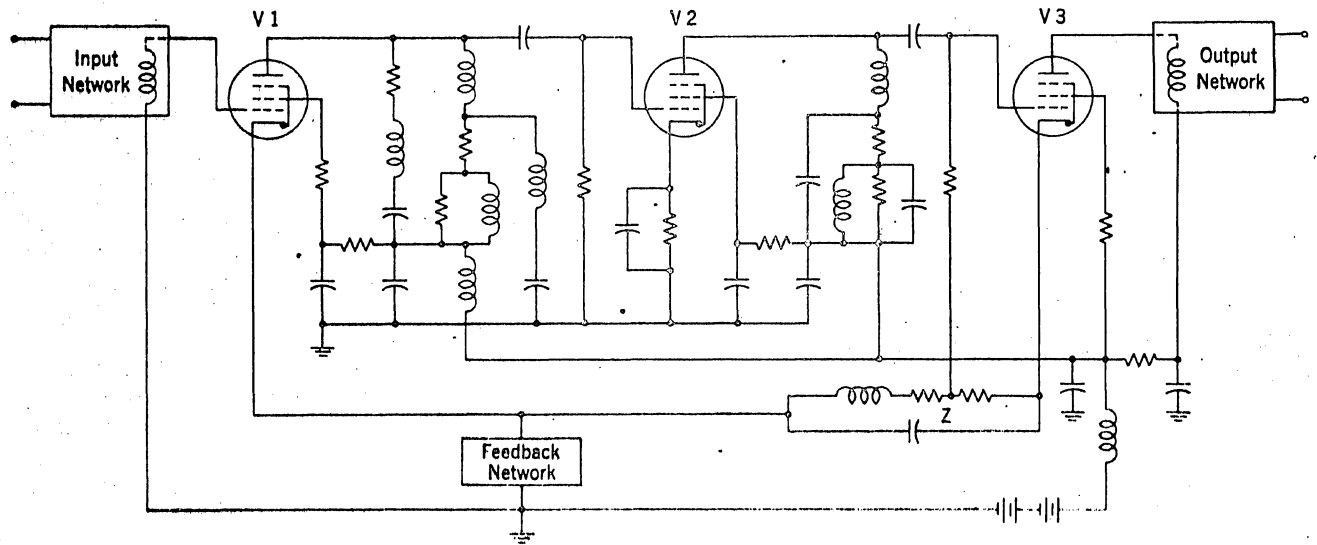

Figure 3-40 L-Carrier Amplifier Circuit (Paralleling Tubes Omitted)

Figure 3-40 shows schematically the circuit of the amplifier used in type L-1 carrier systems, which operate in the range from 60 to 3,000 kc. Although the diagram shows only three tubes, these amplifiers are actually built with paralleling tubes in each stage so that a tube failure will not stop the functioning of the amplifier. Because the amplifier must operate over such a wide frequency range, the interstage networks of this amplifier are quite complex. As a matter of fact, neither of the interstage circuits by itself provides a flat gain, but the two interstages in tandem yield an essentially constant gain between the grid of the first tube and the grid of the last tube over the entire carrier range.

The inter-electrode capacitances of the tubes are minimized by the use of special types of miniature tubes having relatively high transconductance. Two feedback paths are provided, one around the output tube V3, and the other around the entire circuit. The alternating component of the plate current of tube V3 flows from the cathode of that tube through the impedance Z and the feedback network to ground; and thence through the primary of the transformer in the output network to the plate of the tube and back to the cathode. The voltage drop to ground across Z and the feedback network resulting from this current flow is applied to the grid of V3. This local feedback suppresses modulation effects (distortion) developed in the output tube. The alternating voltage developed across the feedback network is applied to the grid of tube V1 through the secondary of the transformer in the input network. This is the main stabilizing feedback of the amplifier circuit. It also provides a means for regulation of the amplifier through appropriate adjustments of the feedback circuit.

CHAPTER 4

OSCILLATORS

4.1 INTRODUCTION

In communications work, the term oscillator is usually applied to electron tube devices which act as generators of a-c sine wave voltages. Practically any vacuum tube amplifier circuit will function as an oscillator if some part of the output energy is returned or fed back in phase to the input. The minimum requirement for sustained oscillation is that the energy so fed back must be at least as much as the reciprocal of the total amplification. That is to say, for example, if the energy amplification of the circuit is 100 times, at least 1/100 of the output energy must be fed back. This is a condition which it is not at all difficult to obtain. In fact, it is usually necessary in the design of any vacuum tube amplifying circuit to take special precautions to avoid the development of an oscillating condition.

4.2 SIMPLE OSCILLATIONS

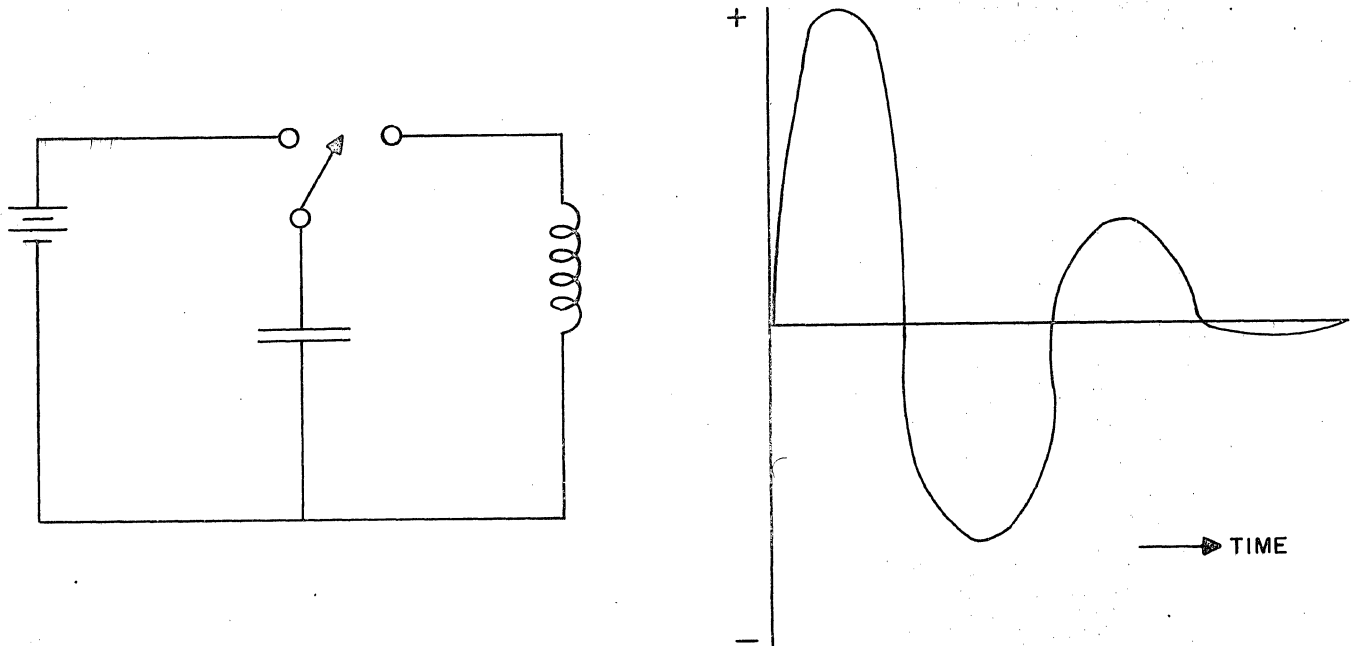

Fig. 4-1 Tank Circuit

CHAPTER 4 OSCILLATORS

Figure 4-1 illustrates the operation of a tank circuit which is composed of a condenser and a coil. If the switch is thrown toward the battery, the condenser will be charged to the battery potential. If the switch is then thrown away from the battery, the condenser will discharge through the coil and, because of the inertia effect of the coil, current will flow until the condenser is charged to the opposite polarity. The current will then reverse and the procedure will continue. The charge of the condenser will be slightly smaller with each alternation because of the circuit losses. The damped oscillation which results will have a frequency which depends on the inductance and the capacity of the coil and the condenser.

Simple Oscillator

Suppose that a tank circuit is placed in the plate circuit of an amplifier. If small impulses are fed into the grid at the right time to overcome the losses of the tank circuit, then instead of a damped oscillation a continuous oscillation will result. The impulses may be supplied to the grid by positive feedback. The frequency of oscillation will be:

$$F = \frac{1}{2\pi\sqrt{LC}} \quad (4:1)$$

There are many possible designs of oscillator circuits.

4.3 TYPES OF OSCILLATORS

Induction Coupled Oscillator

Figure 4-2 represents a simple type of inductively coupled oscillator circuit. Here the amount of energy fed back into the input is determined by the coupling between the coils L_2 and L_1 , and the frequency of oscillation is controlled by the values of L_1 and C_1 in the resonant tank circuit.

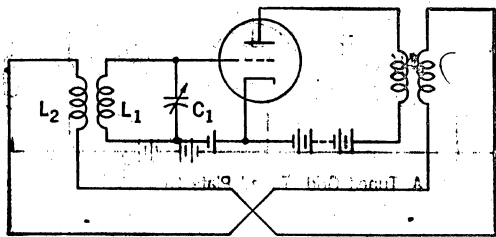

Fig. 4-2 Inductively Coupled Oscillator

CHAPTER 4 OSCILLATORS

Tuned-Plate, Tuned-Grid Oscillator

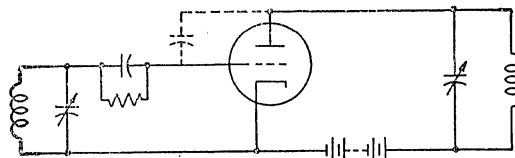

Fig. 4-3 Tuned Grid Tuned Plate Oscillator

Figure 4-3 shows an oscillator circuit in which both the grid and plate circuits include tuned tank circuits. Here the feedback or coupling between the plate and grid is assumed through the interelectrode capacitance of the tube itself. If this is insufficient, it may be effected by the inclusion of a coupling capacitor as indicated by the dotted lines.

Hartley Oscillator

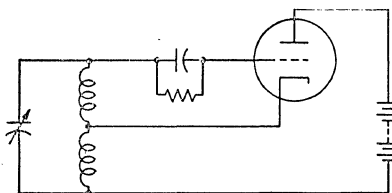

Fig. 4-4 Hartley Oscillator

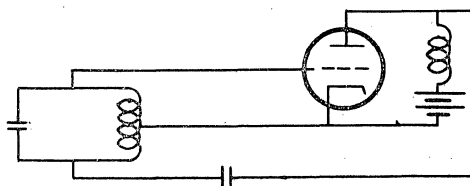

Fig. 4-5 Shunt-Fed Hartley

Figure 4-4 shows the principle of the well-known Hartley oscillator in which the tuned network is connected between the grid and plate of the tube, and the cathode is connected to a tap-point of the inductor. Thus the current flowing in the plate circuit produces a voltage between grid and cathode whose value depends upon the ratio of the inductive reactances on either side of the tap-point. This circuit is the series fed Hartley. Figure 4-5 shows a Shunt fed Hartley oscillator. In this case the d. c. path does not go through the coil.

Colpitts Oscillator

The Colpitts oscillator is similar to the Hartley except that the coil is not tapped. Instead, the cathode is connected to the midpoint of two condensers which replace the Single Condenser of the Hartley circuit.

CHAPTER 4 OSCILLATORS

4.4 OPERATION OF THE OSCILLATOR

It may be noted that grid bias is obtained in both circuits of Figure 4-4 by the use of a grid-leak resistor and capacitor. This arrangement has two advantages. It insures that the oscillator will be self-starting, since at the instant that voltage is first applied to the plate the grid will be unbiased and the tube will be working on a high point of its characteristic curve. This will permit an initial surge of current which will begin to charge the grid-leak capacitor and supply sufficient energy to the tank circuit to start it into oscillation. The first few oscillations will continue to build up the charge on the grid-leak capacitor and drive the grid increasingly negative until a steady-state operating condition is reached in which the energy supplied to the tank circuit is just sufficient to overcome its losses and thus maintain oscillations of a constant magnitude. The grid-leak biasing arrangement also tends to make the oscillator self-regulating because the grid bias will automatically change in accordance with any change in the plate current that may be caused by variations in the load.

The circuits shown in Figures 4-2 and 4-4 do not indicate any load connection, but in any practical case some portion of the plate circuit energy would, of course, be drawn off for application to some other circuit. This can be accomplished by connecting the load directly into the plate circuit, or by connecting it inductively to the coil in the plate tank circuit. It will be evident, however, that such a load connection may affect the constants of the oscillating circuit somewhat, with a possible consequent effect on the oscillating frequency. This may be minimized by inserting a "buffer amplifier" between the oscillator and the load. It may also be avoided by the use of the so-called electron-coupled oscillator shown in Figure 4-6. This circuit employs a tetrode in which the screen grid acts as the plate of an oscillating circuit of the Hartley type. The plate circuit couples the oscillating circuit to the load by means of the varying stream of electrons passing through the screen to reach the plate. Changes in the load impedance thus cannot affect the constants of the oscillating circuit itself.

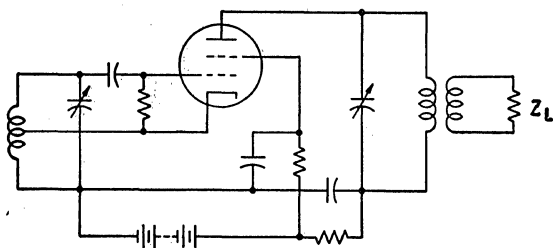
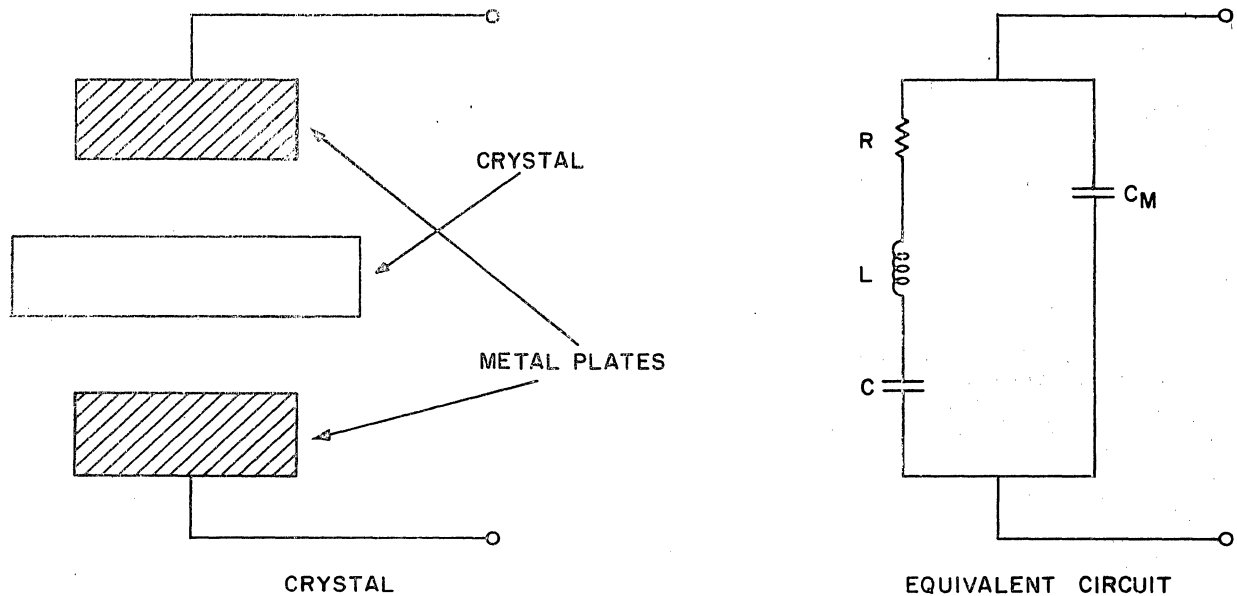

Fig. 4-6 Electron-Coupled Oscillator

CHAPTER 4 OSCILLATORS

4.5 CRYSTAL CONTROLLED OSCILLATORS

Many applications of oscillators in radio and carrier systems require greater stability of frequency than can be readily obtained with the circuits discussed above. The high degree of stability needed in such cases is usually obtained by employing a piezo-electric crystal in place of the ordinary tank circuit, as indicated in Figure 4-7. The crystals usually of quartz, Rochelle salt or tourmaline have electrical properties as shown in Figure 4-8 and may have a Q of 30K or more.



R - RESISTANCE OFFERED TO VIBRATION BY THE CRYSTALS
INTERNAL FRICTION.

L - INDUCTANCE REPRESENTING THE CRYSTALS MASS.

C - CAPACITOR REPRESENTING THE ELASTICITY OF THE
CRYSTAL.

C_M - CAPACITOR FORMED BY THE METAL PLATES.

Figure 4-7, 4-8 Crystal Equivalent

CHAPTER 4 OSCILLATORS

When employed in an oscillating circuit as shown, the output frequency will correspond exactly to the resonant frequency of the crystal regardless of variations that may occur in other reactive components of the circuit, or in the characteristics of the tube. If necessary, even greater stability may be secured by enclosing the crystal in a constant temperature oven to preclude any changes in the crystal itself that might result from changes in the ambient temperature.

Crystals can be cut to have natural fundamental frequencies ranging from a few kilocycles up to about 30 megacycles. Frequencies much higher than this would require making the crystal too thin for practical use. Stable frequencies above this limiting value may be obtained, however, by using frequency multipliers in tandem with a crystal source. These consist essentially of vacuum tube amplifiers operated on a nonlinear basis so that their output contains substantial harmonics of the fundamental frequency. In a frequency doubler, the second harmonic appearing in the output of the amplifier is selected by an appropriate tuned circuit, while a frequency tripler would select the third harmonic. Because of their relative weakness, higher harmonics than these are not ordinarily used, but any desired multiplying factor can be obtained by employing as many doubling or tripling stages in tandem as may be necessary. The stability of the end frequency remains as great as that of the originating crystal because the multiplying factor is always a fixed integral number.

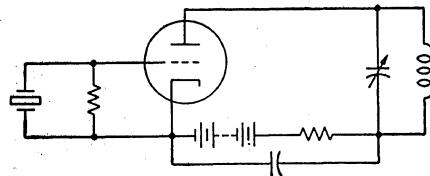

Fig. 4-9 Crystal Controlled Oscillator

4.6 ULTRA HIGH FREQUENCY OSCILLATORS

At ultra-high frequencies, special tubes must be used because the transit time of electrons from cathode to anode becomes an important part of the period of the oscillation. UHF tubes are built with very close-spaced electrodes. At still higher frequencies, positive-grid oscillators, klystrons, magetrons, and backward wave tubes are used. These will be discussed in a later chapter.

CHAPTER 5

AMPLITUDE MODULATION AND DEMODULATION

5.1 INTRODUCTION

In radio communication systems, and in the various types of carrier systems, transmission of signals is effected by impressing the signal voltage on a carrier wave having relatively high frequency. The signal is thus transmitted to its destination by electrical waves whose frequencies are normally more nearly comparable in value to the carrier frequency than to the signal frequency. The basic reason for this procedure in both carrier and radio systems is to make possible the transmission of a number of different signals over the same transmitting medium without mutual interference by placing each signal in a different portion of the frequency spectrum. In radio transmission, such a procedure is also necessitated by the fact that efficient electromagnetic radiation in space can only be attained at high frequencies. It should be noted, however, that the total width of the transmitted carrier frequency band cannot be less than the sum of the bandwidths of all the signals carried--whether the signals are only a few cycles wide as in telegraph, or millions of cycles wide as in television.

The process of impressing the signal on a carrier is known generally as modulation. The inverse process, whereby the signal is retrieved from the modulated carrier-wave, is usually called demodulation in carrier systems and detection in radio systems. There are various methods of modulating carrier waves so that they will effectively transmit signals. The most commonly used of these at the present time are amplitude modulation and frequency modulation. Another form of modulation becoming more prevalent is that of pulse code modulation. (PCM).

5.2 GENERAL

In amplitude modulation, the amplitude of the carrier wave is varied in accordance with the variations of the signal wave. The degree of difficulty involved in modulation depends upon the nature of the signal. For a telegraph signal such as that shown in Figure 5-1 (A), the method is very simple and consists merely in interrupting the supply of carrier frequency to the line during negative pulses of the telegraph signal and permitting it to flow during positive pulses. The result is a series of "spurts" of current at the frequency of the particular carrier channel as indicated in Figure 5-1 (C).

CHAPTER 5 AMPLITUDE MODULATION AND DEMODULATION

In telephony, since the variations in voice current are much more complex than telegraph current, the process is more involved. This is indicated by Figure 5-2 where A is a representation of the unmodulated carrier, B is a representative voice signal, and C is the modulated carrier. It will be noticed that the outline or "envelope" of the modulated wave has the form of the voice signal wave. This effect is not different in principle from the action of an ordinary telephone transmitter, where the direct current supplied by the local or central office battery is varied or modulated by the sound waves of the voice impinging on the transmitter button. The output current from the transmitter is then a varying direct current consisting of the initial unvarying battery current, with the changing voice current superimposed upon it.

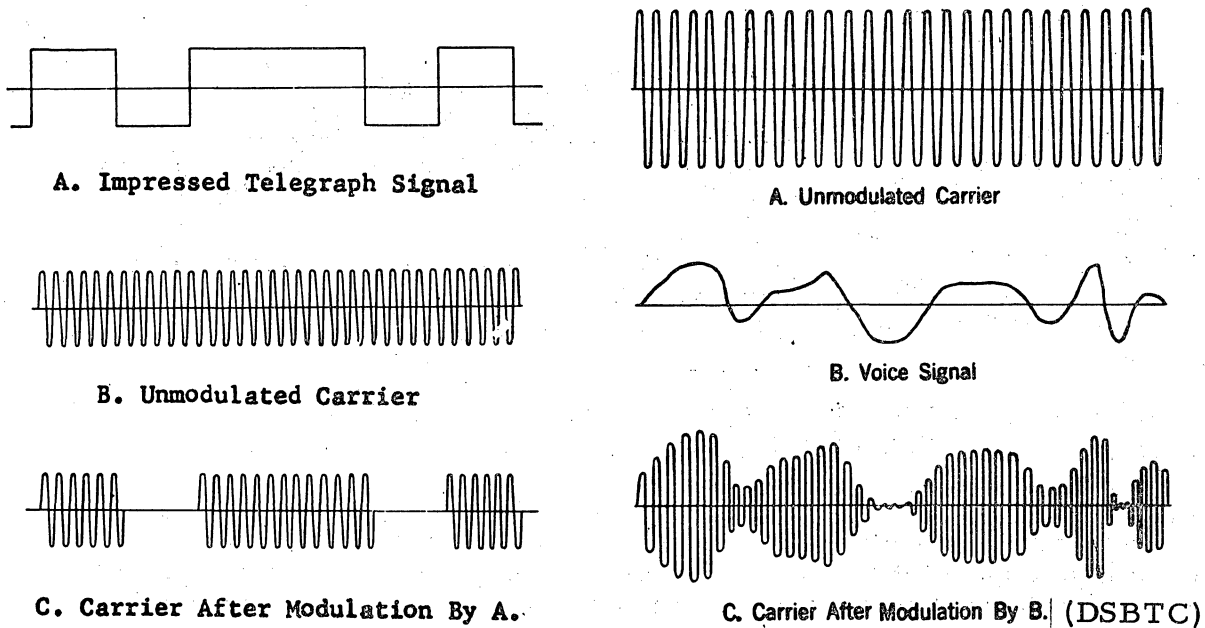

Figure 5-1. Modulation in Telegraph Systems

Figure 5-2. Modulation in Telephone Systems

CHAPTER 5 AMPLITUDE MODULATION AND DEMODULATION

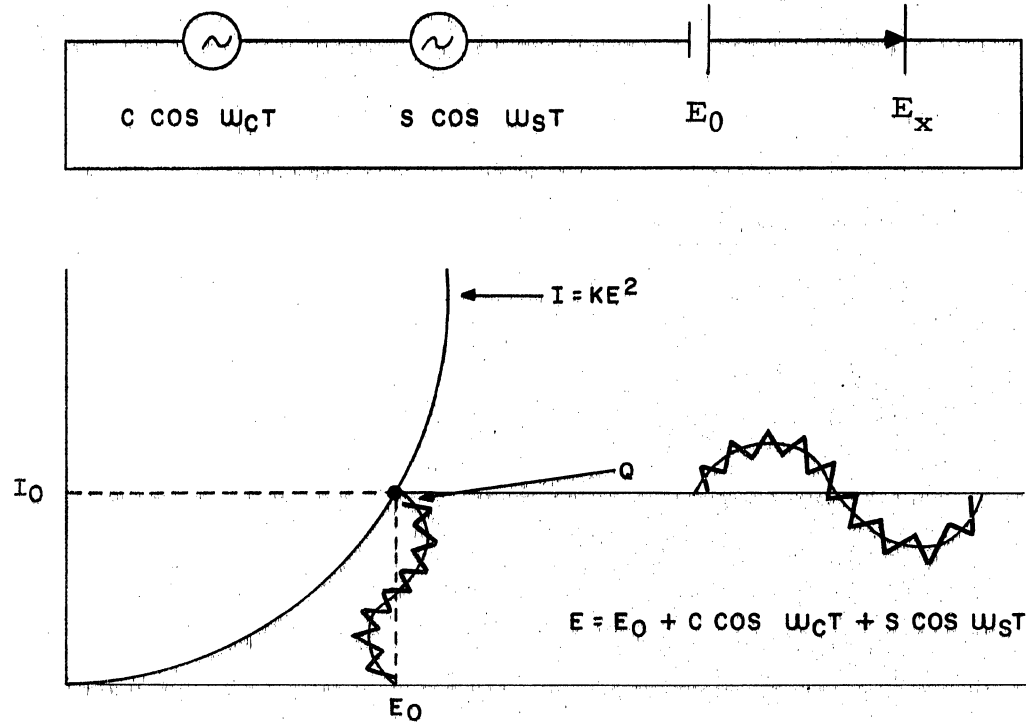

Figure 5-3 Basic Modulator

A simple modulator circuit consisting of a carrier generator, signal generator, a battery and a rectifier is shown in figure 5-3. With no carrier or signal voltage applied, the relationship between E_0 the biasing voltage and the current is plotted as shown. Point Q on the curve represents the quiescent operating point which would be fixed by the voltage E_0 . If the rectifier obeys exactly the square law current voltage relationship then:

$$I = KE^2$$

If the carrier & signal generator are now introduced:

$$E_x = E_0 + C \cos W_c t + S \cos W_s t$$

CHAPTER 5 AMPLITUDE MODULATION AND DEMODULATION

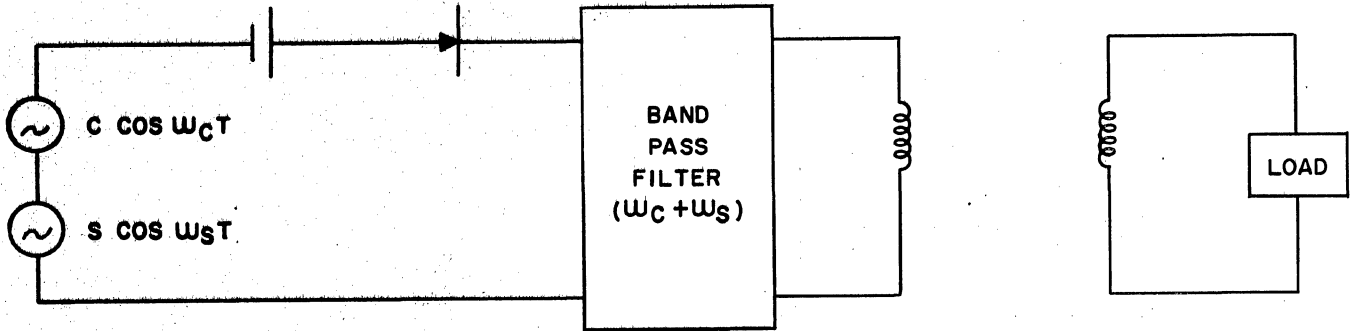

Figure 5-4 Modulator

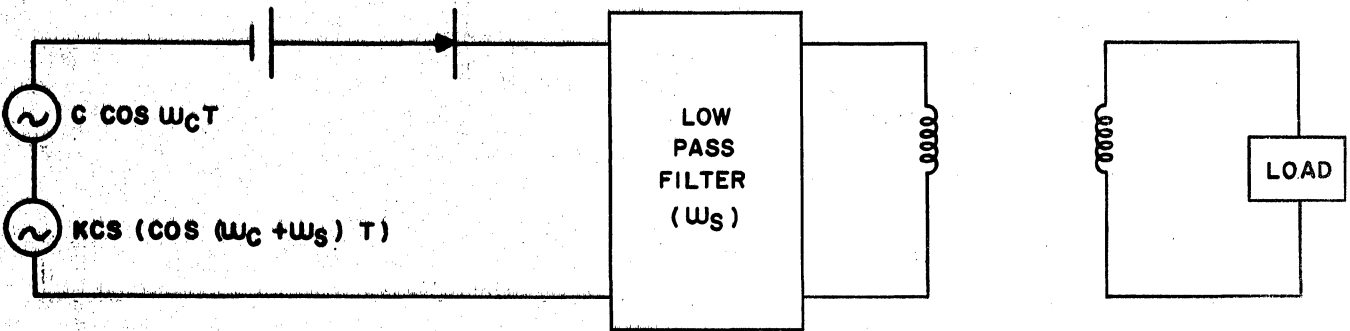

Figure 5-5 Demodulator

CHAPTER 5 AMPLITUDE MODULATION AND DEMODULATION

Squaring E_x and substituting for I yields:

$$\begin{aligned} I = & K \left(E_0^2 + \frac{C^2}{2} + \frac{S^2}{2} \right) \\ & + 2KE_0 (C \cos W_C t + S \cos W_S t) \\ & + \frac{K}{2} (C^2 \cos 2W_C t + S^2 \cos 2W_S t) \\ & + KCS \left[\cos (W_C + W_S)t + \cos (W_C - W_S)t \right] \end{aligned}$$

The current in the circuit now contains components at frequencies other than W_C & W_S . The frequencies are:

- a. The DC component
- b. W_C & W_S the input components
- c. $2W_C$ & $2W_S$ twice the inputs
- d. $W_C + W_S$ sum of inputs
 $W_C - W_S$ difference of inputs

The components $(W_C + W_S)$ and $(W_C - W_S)$ should be recognized as the upper and lower side-bands respectively.

If we modify our modulation circuit slightly as shown in Figure 5-4 to introduce a band pass filter which will pass only the upper side-band, the process of modulation is complete. The intelligence at some frequency W_S has been multiplexed and is now contained in an upper side-band at a frequency $(W_C + W_S)$.

A demodulator as shown in figure 5-5 includes the same equipment as the modulator, however, input frequencies would be W_C and $(W_C + W_S)$. From the combinations a filter would separate W_S .

5.3 ELECTRON TUBE MODULATORS

Where triodes are used as modulators in carrier telephone systems, the modulating effect is usually obtained by applying a biasing voltage to the grid of the triode of such magnitude that the tube operates on a definitely curved portion of its grid voltage-plate current characteristic. Under these conditions, the amplification supplied by the tube will not be constant but will vary with the value of any alternating voltage applied to the grid.

In the simple circuit of Figure 5-6 assume that a voice voltage represented by A is connected to the circuit through a transformer, together with the carrier voltage represented by B. For simplicity the voice voltage is here assumed to be sinusoidal in form although this, of course, is not generally the case. The two voltages, being in series, add together to give the voltage represented by C impressed on the grid of the tube. Now if the C battery or bias of the tube is given the value indicated

CHAPTER 5 AMPLITUDE MODULATION AND DEMODULATION

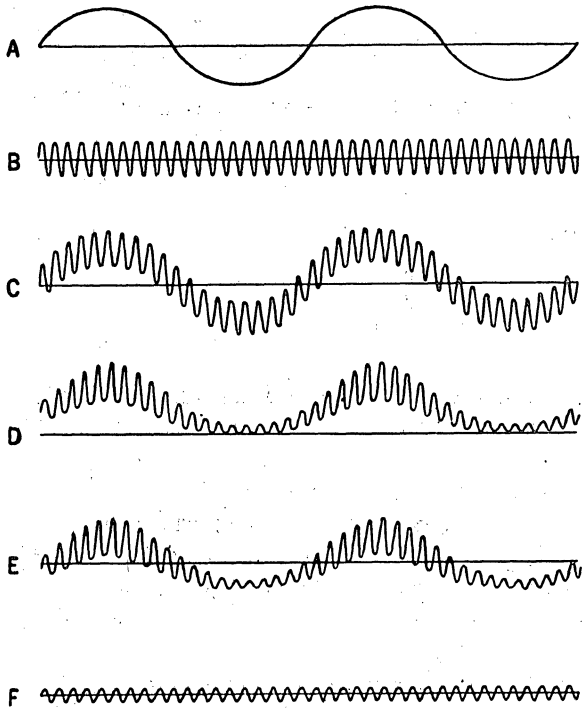
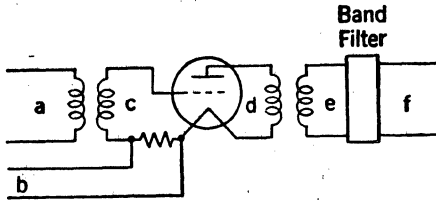

Figure 5-6 Currents in Modulator Circuits

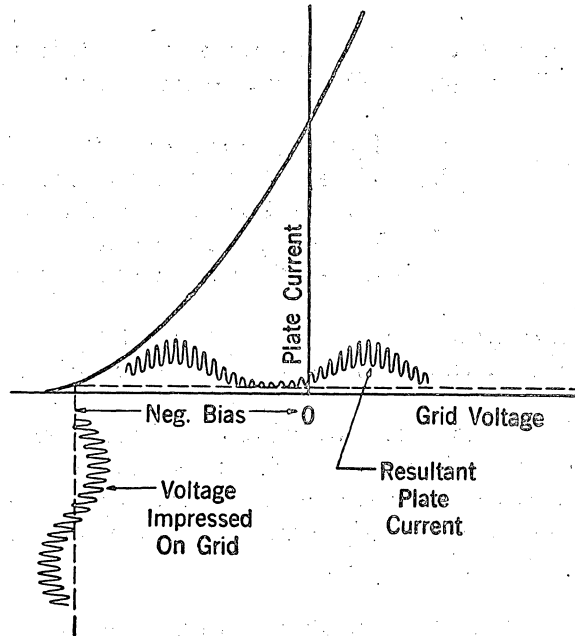

Figure 5-7 Vacuum Tube as Modulator

by Figure 5-7 and the characteristic curve of the tube is as there shown, the impressed control grid voltage will cause a plate current of the form shown in Figure 5-6 (D). After passing through the output transformer, the current curve will be as pictured in Figure 5-6 (E). Analysis of this curve shows the principle frequencies present in terms of the voice and carrier frequencies to be:

- V - The voice frequency
- C - The carrier frequency
- 2V - Twice the voice frequency
- 2C - Twice the carrier frequency
- C - V - The difference between the carrier and the voice frequencies
- C + V - The sum of the carrier and voice frequencies

CHAPTER 5 AMPLITUDE MODULATION AND DEMODULATION

5.4 COPPER OXIDE VARISTORS

Many types of carrier telephone systems employ copper-oxide varistors instead of electron tubes in their modulating and demodulating circuits. These devices are capable of accomplishing essentially the same results.

Varistors are VARIABLE resISTORS and derive their name from the first three letters of the word variable and the last six letters of the word resistors. Varistors are classed as "metallic rectifiers" or as "crystal rectifiers" such as the copper-oxide, selenium, or germanium crystal rectifiers. All classes of varistors are in general made of semi-conductors, that is, material whose conductivity lies between that of conductors and insulators. The copper-oxide varistor is a sandwich consisting of a layer of cuprous-oxide on copper. These cells are produced by heating a copper disc, in a furnace to a temperature of about 1,000 degrees F and then quenching it in water. This treatment produces a thin film of cuprous-oxide with an outer layer of cupric-oxide. The cupric-oxide is removed leaving a thin layer of cuprous-oxide on one side. Contact with the copper-oxide surface can be made by holding a lead disc against the oxide surface under pressure or by electroplating a nickel coating on the surface of the oxide. These discs are shaped like washers and are assembled alternately with lead washers on a bolt so they can be clamped tightly together (with a pressure of 500 to 2,000 pounds per square inch) to secure good electrical contact. The lead nickel or other conducting material applied to the outer surface of the oxide is known as the "outer contact". When a potential is applied between the copper and the outer contact, it is found that the current is not proportional to the applied voltage and that it depends on the direction of the applied potential. Such a combination offers a low resistance path to electron flowing from the copper to the copper-oxide but a high resistance path to the electron flowing from the copper-oxide to the copper. A complete assembly is known as a "varistor" and the number of discs necessary in each assembly (or stacks) is determined by the voltage of the current to be rectified and the number of stacks which must be connected in parallel is determined by the amperage output desired.

The copper-oxide varistor, whose cross section is shown in Figure 5-8, consists of a disc of copper, oxidized on one side to give a layer of red cuprous-oxide, which is a semiconductor. The other surface of the oxide layer is coated with a metallic film to form the second terminal of the device. The resistance of a copper-oxide varistor is very low for one polarity of the applied voltage (called the "forward" or "conducting" direction) and very high for the other polarity. A typical voltage-resistance characteristic of a copper-oxide varistor is shown in Figure 5-9, where the current is plotted in terms of amperes per square inch area of the disc. The slopes of this curve correspond to a resistance of about 1/4 ohm in the forward direction and about 2,000 ohms in the reverse direction,

CHAPTER 5 AMPLITUDE MODULATION AND DEMODULATION

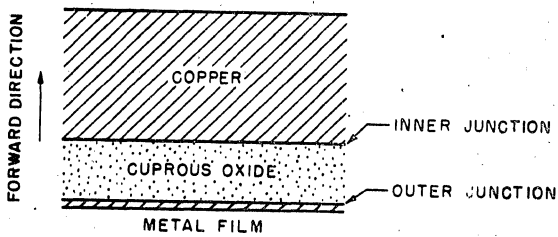

Figure 5-8 Cross Section of Copper-Oxide Varistor

for an area of one square inch. (Actual copper-oxide varistors usually have an area much less than one square inch, a representative size being a disc 3/16 inch in diameter.)

A varistor has considerable advantage over a vacuum tube because it is compact, requires no auxiliary power, is long lived, and needs little maintenance. It is however limited in use to frequencies below about 4 megacycles, because of internal capacitance.

As in the case of electron tubes there are a number of possible circuit configurations for copper-oxide modulators. The two in most common use are shown in Figures 5-10 and 5-13.

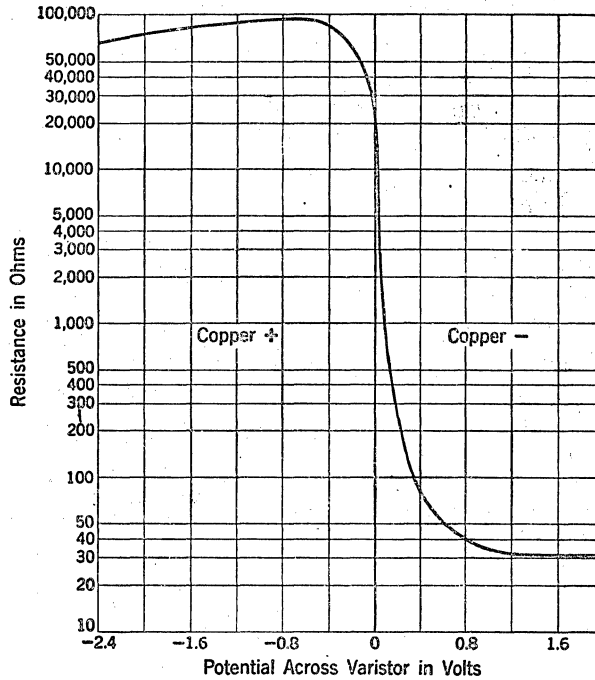

Figure 5-9 Resistance Characteristic of a Copper-Oxide Varistor

CHAPTER 5 AMPLITUDE MODULATION AND DEMODULATION

Its essential characteristic for the present purpose is that, as shown in Figure 5-9, its resistance varies with the magnitude and polarity of the applied voltage. This is a typical curve for a single disc-shaped copper-oxide unit having a diameter of 3/16 inch. It will be noted that the resistance of the unit varies from a relatively low value when the copper is negative with respect to the copper-oxide, to a very high value when the voltage polarity is reversed.

5.5 VARISTOR MODULATORS AND DEMODULATORS

For use as modulators and demodulators in carrier systems, four of these tiny copper-oxide units are mounted in a sealed container having a maximum dimension of less than one inch. The characteristics of such units are very stable and their useful life is apparently indefinite under normal operation,

In the channel modulator and demodulator circuits of most carrier systems, the varistor units are connected in the Wheatstone bridge arrangement illustrated in Figure 5-10. (In the symbols used here for the varistor units, the copper-oxide is represented by the arrow, and the copper by the crossbar. The conducting direction of the unit is thus in the direction of the arrow point.) The carrier voltage, C , is made very large as compared with the signal voltage, V , so that the resistance presented by the varistor units is effectively under the control of the carrier voltage alone. In other words, the resistance of the varistors varies from a low value to a high value at the frequency of the applied carrier voltage.

Under these circumstances, the network of varistors will act to virtually short-circuit the line during the positive halves of the carrier voltage cycle; and to present an open circuit across the line during the negative

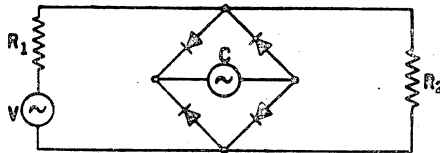

Figure 5-10 Balanced Bridge Modulator Circuit

halves of the carrier voltage cycles. This is illustrated by the two diagrams of Figure 5-11 where the varistors are indicated as perfect conductors during the positive pulse and as opens during the negative pulse. The effect on the applied signal voltage, V , is therefore to block it completely during the positive half of the carrier cycle and to permit its free transmission during the negative half of the carrier cycle. The varistors thus act effectively like a switch, opening and closing at the frequency of the carrier voltage. The resultant output current is shown in Figure 5-12.

CHAPTER 5 AMPLITUDE MODULATION AND DEMODULATION

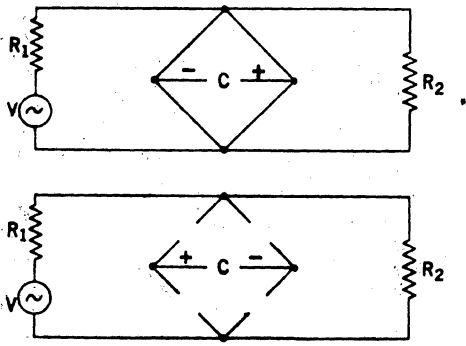

Figure 5-11 Operating Principle of Circuit of Figure 5-10

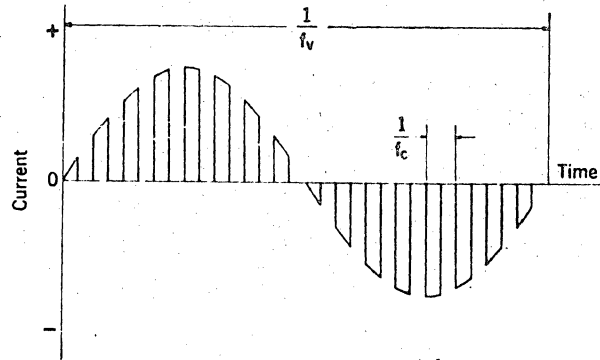

Figure 5-12 Output Current of Balanced Bridge Modulator

An analysis of this current curve would show that its principal components are the signal frequency and the upper and lower side-bands of the carrier frequency. If we assume for the signal voltage a sine wave of the form -

$$e = A \sin Vt$$

where A represents the amplitude of the signal and V is 2 times the signal frequency, an approximate equation for the output current represented by Figure 5-12 may be written as follows:

$$I = \frac{A \sin Vt}{2(R_1 + R_2)} + \frac{2A}{\pi(R_1 + R_2)} [\sin Vt \sin Ct + \frac{1}{3} \sin Vt \sin 3Ct + \frac{1}{5} \sin Vt \sin 5Ct + \dots] \quad (5:1)$$

Here R_1 and R_2 are respectively the input and output resistances as indicated in Figure 5-10 and C is 2 times the carrier frequency.

Making use of the trigonometric relationship -

$$\sin \theta \sin \phi = \frac{1}{2} \cos (\theta - \phi) - \frac{1}{2} \cos (\theta + \phi),$$

the above equation may be rewritten as -

$$I = \frac{A \sin Vt}{2(R_1 + R_2)} + \frac{A}{\pi(R_1 + R_2)} [\cos (C - V)t - \cos (C + V)t + \frac{1}{3} \cos (3C - V)t - \frac{1}{3} \cos (3C + V)t + \frac{1}{5} \cos (5C - V)t - \frac{1}{5} \cos (5C + V)t + \dots] \quad (5:2)$$

CHAPTER 5 AMPLITUDE MODULATION AND DEMODULATION

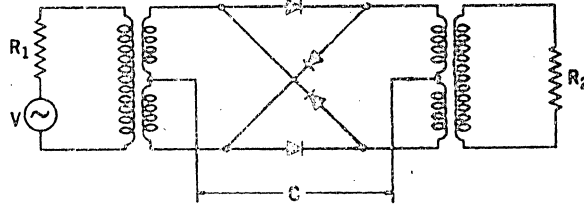

Figure 5-13 Lattice Modulator Circuit

The first term of this equation represents the original signal voltage with a reduced amplitude. The first two terms inside the brackets are the lower and upper side-bands of the modulated carrier wave, and the remaining terms in the brackets represent similar upper and lower side-bands of odd multiples of the carrier frequency. The equation does not include any term for the carrier frequency itself, showing that the carrier is suppressed by the balanced arrangement of the varistors.

In practice, only one of the side-bands of the carrier frequency is made use of in most cases and this is selected from the several frequency terms appearing in the output by means of a suitable band-pass filter. A demodulator arrangement, identical to that shown in Figure 5-10, is used at the receiving end of the carrier line to restore the original signal frequency. In this case, the frequencies applied to the varistor circuit (demodulator) are the received side-band and a locally generated carrier identical in frequency to that supplied to the modulator at the sending end. Thus, if we assume that the lower side-band is transmitted, the signal frequency applied to the demodulator may be indicated in the form, $K \cos (C - V)t$. When this term is substituted in equation (5:1) in place of $A \sin Vt$, the first term inside the brackets in equation (5:2) will become:

$$\cos [C - (C - V)] t = \cos Vt$$

This is the desired original signal and it can be selected from the other components of demodulation by the use of a simple low-pass filter.

For the group modulators and demodulators of broad-band carrier systems, a somewhat different arrangement of the varistor units is frequently employed. This is illustrated in Figure 5-13. It is also a balanced bridge arrangement but the circuit connections and the configuration of the varistors are such that, as indicated in Figure 5-14, the signal voltage is impressed across the output transformer in one direction during one-half of the carrier cycle, and in the other direction during the other half of the carrier cycle. In other words the circuit acts like a reversing switch operating at the carrier frequency and results, in the ideal case, in the output current wave shown in Figure 5-15.

CHAPTER 5 AMPLITUDE MODULATION AND DEMODULATION

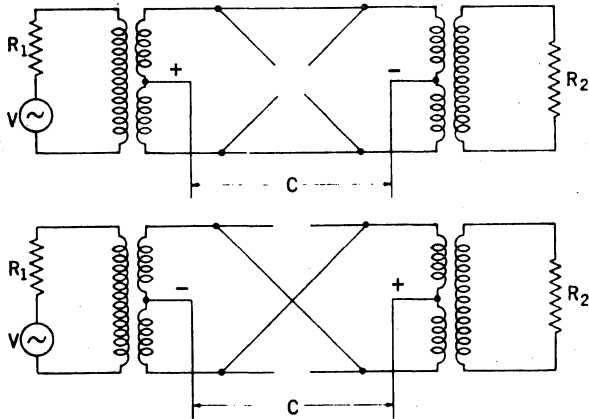

Figure 5-14 Operating Principle of Circuit of Figure 5-13

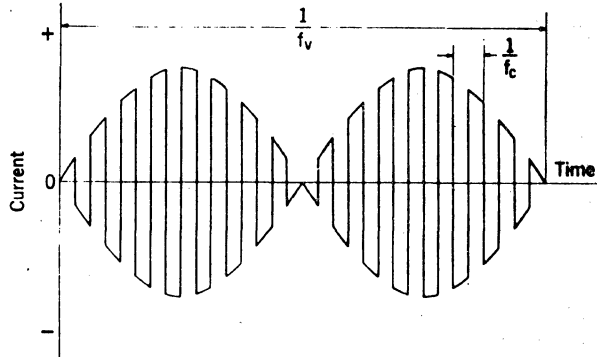

Figure 5-15 Output Current of Lattice Modulator

Using the same terminology as in the preceding discussion, the approximate equation for the curve of Figure 5-15 is -

$$\begin{aligned}
 I = \frac{2A}{\pi(R_1 + R_2)} & [\cos(C - V)t - \cos(C + V)t \\
 & + \frac{1}{3} \cos(3C - V)t - \frac{1}{3} \cos(3C + V)t \\
 & + \frac{1}{5} \cos(5C - V)t - \frac{1}{5} \cos(5C + V)t + \dots] \quad (5:3)
 \end{aligned}$$

Comparing this equation with (5:2), it will be noted that the desired sidebands are still present in the first two terms in the brackets, and the carrier is likewise suppressed. The signal frequency term, however, is no longer present. Moreover, the amplitudes of the sidebands are twice as great as in the previous case. This modulator therefore has the advantage of automatically suppressing the unwanted signal frequency components and of providing a larger output of the desired sidebands. These characteristics are particularly desirable in group modulators where the wide band transmitted makes maximum side-band output, and the reduction of the number of unwanted products, very important. This arrangement of course operates as a demodulator in exactly the same way and has the same advantages.

In both of the examples of copper-oxide modulator operation discussed above, it was assumed for the sake of simplicity that the varistors acted as perfect rectifiers and were perfectly balanced in the bridge configuration. In practice, this ideal condition can only be approximated. The varistors do not actually present zero resistance to the transmission of current in one direction and infinite resistance to transmission in the other direction. Nor, as may be seen from Figure 5-9, is the transition from high resistance to low resistance as sharp as might be desired. Exact balance between the four varistors in the bridge connections is also a condition which can only be approached in practice.

CHAPTER 5 AMPLITUDE MODULATION AND DEMODULATION

As a result of the above practical facts, the modulator and demodulator outputs always contain numerous components additional to those indicated by equations (5:2) and (5:3), including the carrier frequency itself. Most troublesome of these unwanted components, probably, are harmonics of the signal frequency which may fall within the range of the useful side-band and thus cause distortion. Except for such frequencies as this, the unwanted components can be completely eliminated by means of suitable filters. However, it is of course desirable that as large a part as possible of the total output energy should appear in the wanted components. This result can be effected to a considerable degree by properly proportioning the values of the applied signal and carrier voltages. Finally, it is worth noting that where greater output energy is required, each varistor can be made up of a number of individual units or discs connected in multiple or series-multiple.

The departure of the varistor characteristic from the ideal introduce frequency components at the modulator output in addition to those present in the above equations. This distortion is reduced in magnitude by making the signal voltage small in comparison to the carrier voltage. The modulator of Figure 5-13 has an inherent advantage over the modulator of Figure 5-10 in reducing the number of these additional frequencies, in that this circuit is essentially made up of two modulators which when operated together balance out any even harmonics present in much the same manner as in push-pull vacuum tube circuits. This characteristic is very desirable in a group modulator where the wide band transmitted makes the reduction of the number of unwanted products very important.

A number of other configurations of varistors are possible which will give results similar to those discussed herein. The particular arrangement of varistors in a modulator, as well as the size and number of discs in each varistor which will offer the greatest advantage in any specific case can only be determined in relation to the circuit design as a whole.

Modulation in radio systems ordinarily involves substantially larger amounts of power than the carrier systems discussed above. Considerations of power efficiency, therefore, are of much greater importance. Also, because of the much larger power requirements, electron tubes must always be used in the modulating circuits since any practical varistor arrangement would be inadequate to handle the required power.

Demodulation in radio systems involves the same principles as were outlined above in connection with carrier systems. But the particular devices used in this case are generally known as detectors.

CHAPTER 6

TYPE "C" CARRIER SYSTEM

6.1 GENERAL

The type "C" system made its appearance in the 1920's. It was the first really successful carrier system and is still an important member of the family of carrier systems. It was originally designed before the day of varistor types of modulators and feed-back amplifiers, and has appeared in a succession of improved designs known as the C1, C2, C3, C4, and C5 systems. The last and current standard model, the C5, is a fairly complete redesign to incorporate the advantages of the modern techniques of varistor modulators, filters with molybdenum permalloy coils, new types of vacuum tubes, and feedback amplifiers. This section will describe in particular the C5 system with occasional reference to the earlier models of the type "C" system. It operates on open wire facilities and provides three telephone circuits in addition to the normal voice-frequency circuit.

The frequency allocations used in the type "C" systems lie between 6 and 15.5 kc for transmission from East to West and between 18 and 28 kc for transmission from West to East. The upper and lower halves of this range are used for the opposite directions of transmission, as they are in the type "J" systems. However, these are reversed from the type "J" system arrangement, the east-to-west channels occupying the lower and the west-to-east channels the upper frequencies in the type "C" systems. The channels are single-sideband with suppressed carriers. To reduce crosstalk, there are several "staggered" frequency allocations, some using upper and others using lower sidebands. The C4 system was provided in three allocations, known as CN, CS, and CT. The C5 system is available in four allocations, the CA, CB, CS, and CU. These allocations are shown in Figure 6-1.

It will be noted that the "allocations" differ from each other not only in the frequencies the channels occupy but also in whether the channels are upper or lower sidebands.

CHAPTER 6 TYPE "C" CARRIER SYSTEM

TYPE C CARRIER TELEPHONE SYSTEM
FREQUENCY ALLOCATIONS

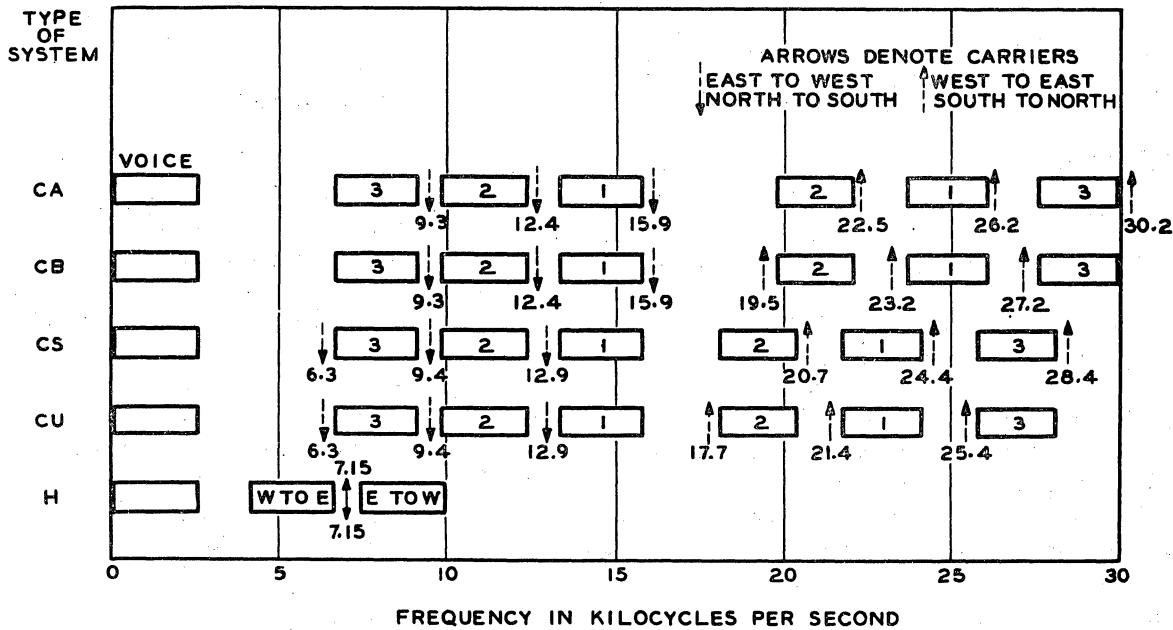

Fig. 6-1 - Frequency Allocations of Type C and H Carrier Systems

Unlike the more complicated systems described in other chapters, the type "C" systems translate each telephone channel to its assigned frequency position on the line in a single stage of modulation. The required carriers are not multiples of any base frequency but are generated by individual oscillators, one for each modulator and demodulator. One pilot is transmitted in each direction on all of the type "C" systems. The pilot frequency is located 50 cycles from the frequency of the suppressed carrier of the middle channel, between the carrier and the transmitted sideband. In the longer systems, the pilots are used for the automatic regulation of the systems. In the systems which are so short as to have no repeaters, the regulation may be manual.

The type "C" systems are designed so that the repeater spacings are the same as for the voice-frequency systems (about 150 miles) and therefore the repeaters are located in the same stations as the voice repeaters. The present C5 system is composed of the C5 terminals, the C1 repeater, and the 2B carrier pilot channel, all coded separately. These will now be briefly described.

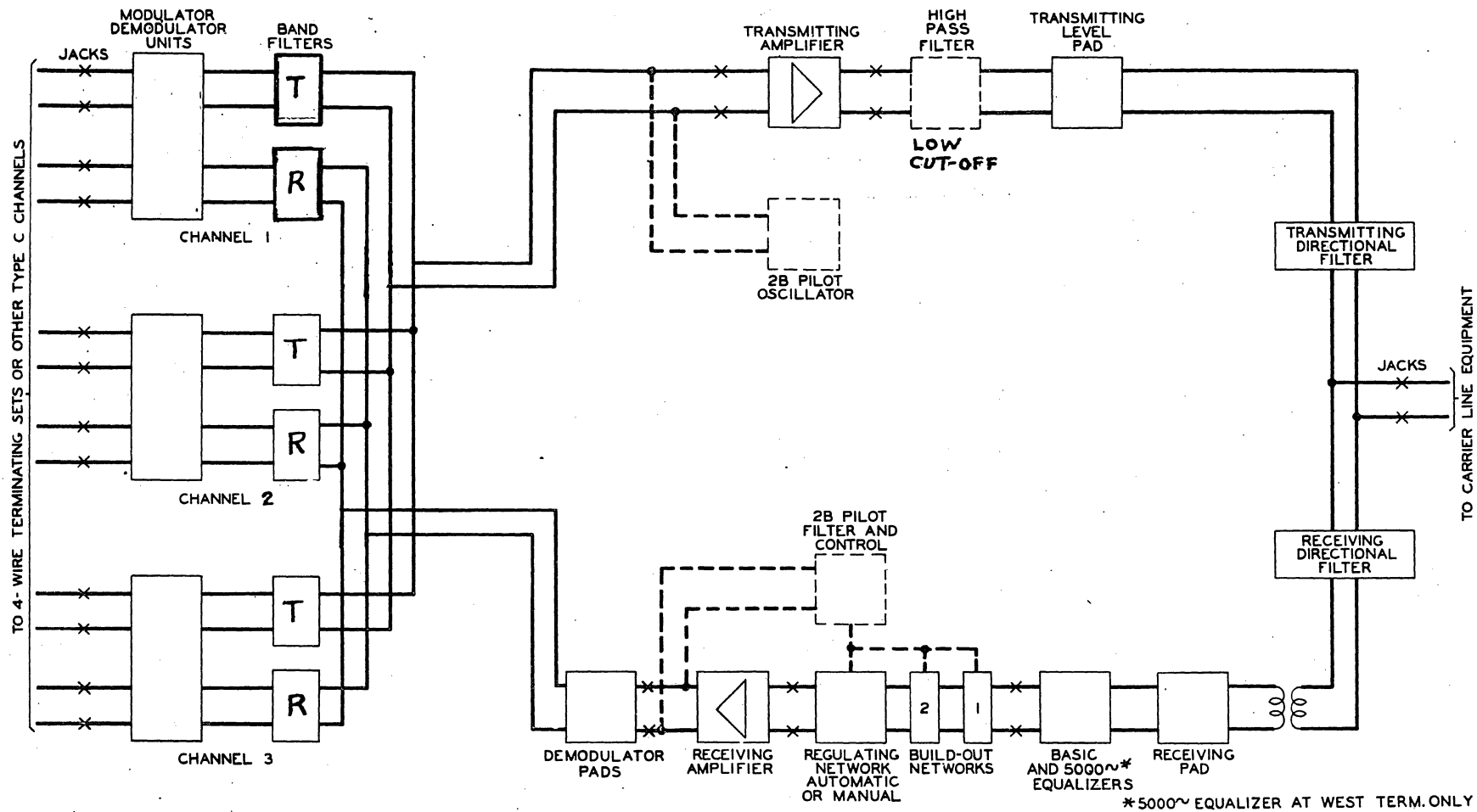

Figure 6-2 - Block Schematic of C5 Terminal

CHAPTER 6 TYPE "C" CARRIER SYSTEM

6.2 THE C5 TERMINAL

A block diagram of a C5 terminal is shown in Figure 6-2. The left-hand leads are the three voice-frequency telephone circuits on a 4-wire basis. They come from the 4-wire switches in a 4-wire switching office, or from 4-wire terminating sets in a 2-wire switching office. Each 4-wire telephone circuit goes to a modem unit and associated filters, which make the required translations between voice and line frequencies. The outputs of the transmitting branches of the three modems are paralleled together, and the signals are amplified by a common transmitting amplifier and applied to the line through a directional filter. Coming from the line, the three incoming channels are separated from the outgoing channels by a directional filter and are applied to the receiving branch of the terminal. This includes equalizers, a regulating network, and a receiving amplifier. The three incoming channels, after leaving the receiving amplifier, are separated from each other by the demodulator band filters and applied to their respective modems. The portions of the 2B carrier pilot channel equipment included in the terminal are shown by dotted lines. It will be noted that the pilot is applied at the input of the transmitting amplifier. Each modem unit consists of a channel modulator and a channel demodulator. These are shown separately in Figures 6-3 and 6-4. It will be noted that each circuit includes an individual carrier oscillator for generating the required carrier frequency. The modulators are copper oxide bridge-type modulators. It was necessary in the vacuum tube modulator in the C4 terminals to adjust the modulator balance for minimum carrier leak by means of variable capacitors. No such adjustment is required in the copper oxide modulators of the C5 terminals, because of the greater uniformity and stability of the copper oxide varistors, compared with vacuum tubes.

The transmitting and receiving amplifiers are the same as the amplifiers used in the repeaters, and will be described below. They are 2-stage feed-back amplifiers having a substantially fixed flat gain from 5 to 35 kilocycles, which may be made either 50 or 52 decibels by a soldered adjustment. The gain of the transmitting amplifier is 52 decibels, and the gain of the receiving amplifier is 50 decibel. The transmission level of the outgoing channels on the line is +18 decibels with respect to the sending toll switchboard. The receiving branch of a terminal up to and including the receiving amplifier is similar to the circuits of one branch of a repeater, and will be described below. It includes a regulating network which is automatically controlled by the pilot when the 2B carrier pilot channel equipment is used. On short, nonrepeated systems in which the 2B pilot equipment is omitted, a manually adjustable potentiometer is substituted for the regulating network.

CHAPTER 6 TYPE "C" CARRIER SYSTEM

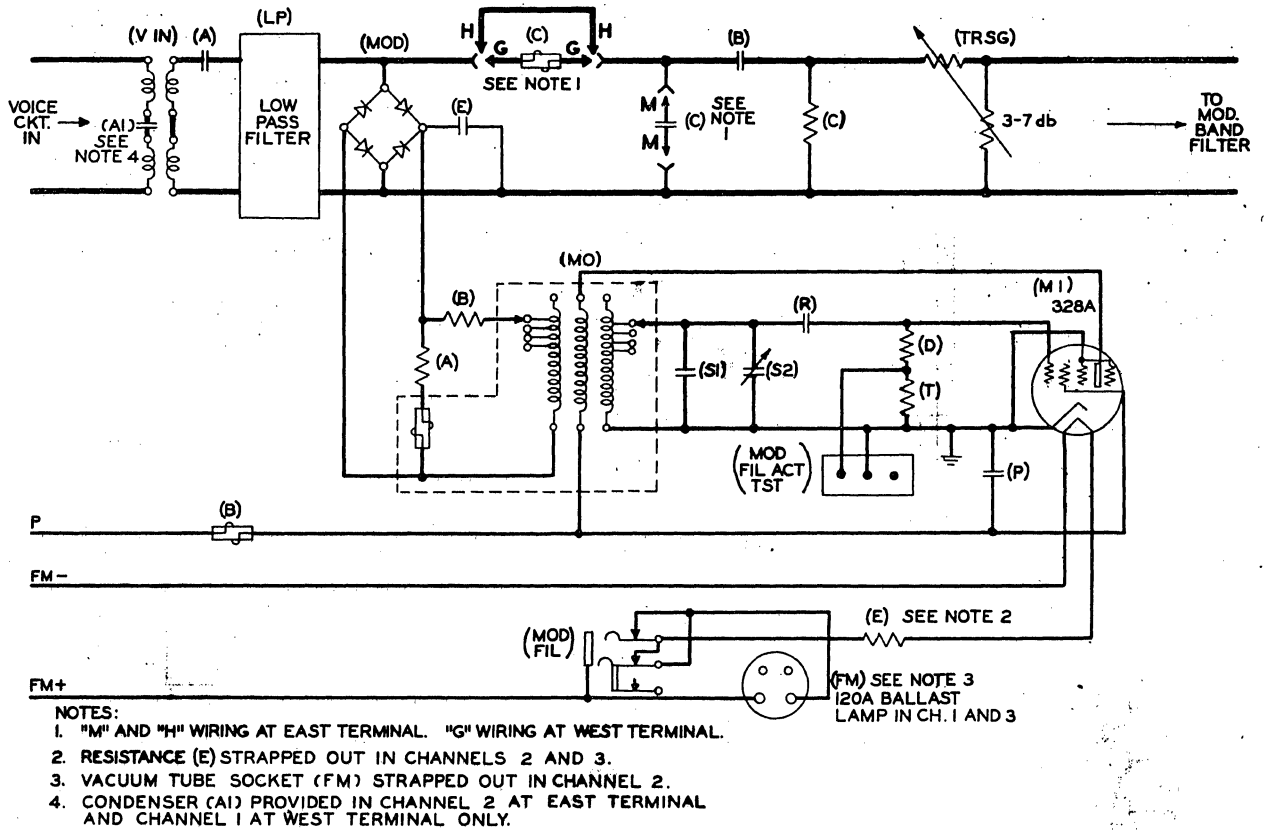

Fig. 6-3 - Schematic of Channel Modulator

(Part of Modem Unit)

CHAPTER 6 TYPE "C" CARRIER SYSTEM

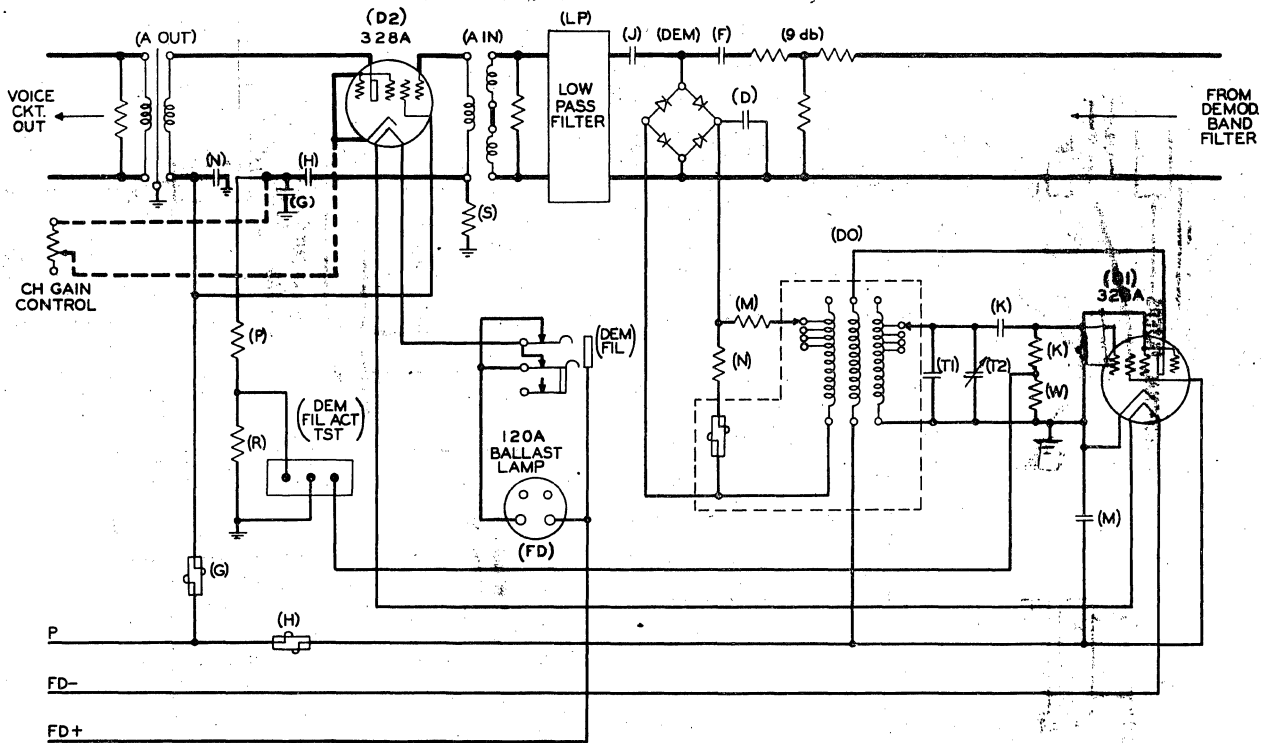

Fig. 6-4 - Schematic of Channel Demodulator

6.3 THE C1 REPEATER

A block diagram of the C1 repeater is shown in Figure 6-5. The two directions of transmission are separated at each end of the repeater by the usual directional filters. Between the filters, the repeater consists of two one-way amplifying and regulating circuits. The amplifier itself, which is the same as the transmitting and receiving amplifiers of the C5 terminals is shown in Figure 6-6. It will be noted that the input and output transformers are in the form of hybrid coils, with the negative feed-back circuit (equalizer (A)) connected to terminals of the coils which are conjugate to the line terminals.

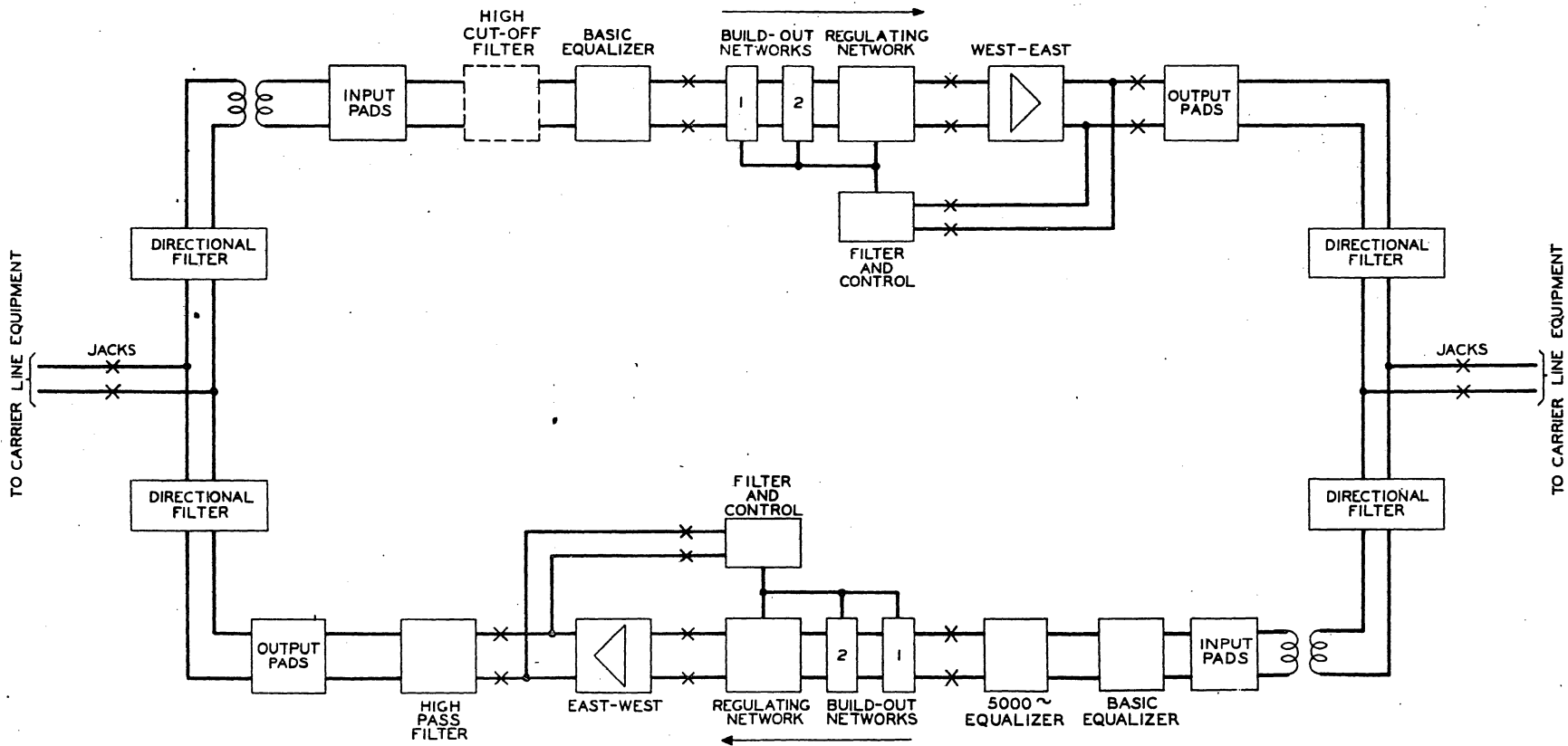

Fig. 6-5 - Block Schematic of C1 Repeater

CHAPTER 6 TYPE "C" CARRIER SYSTEM

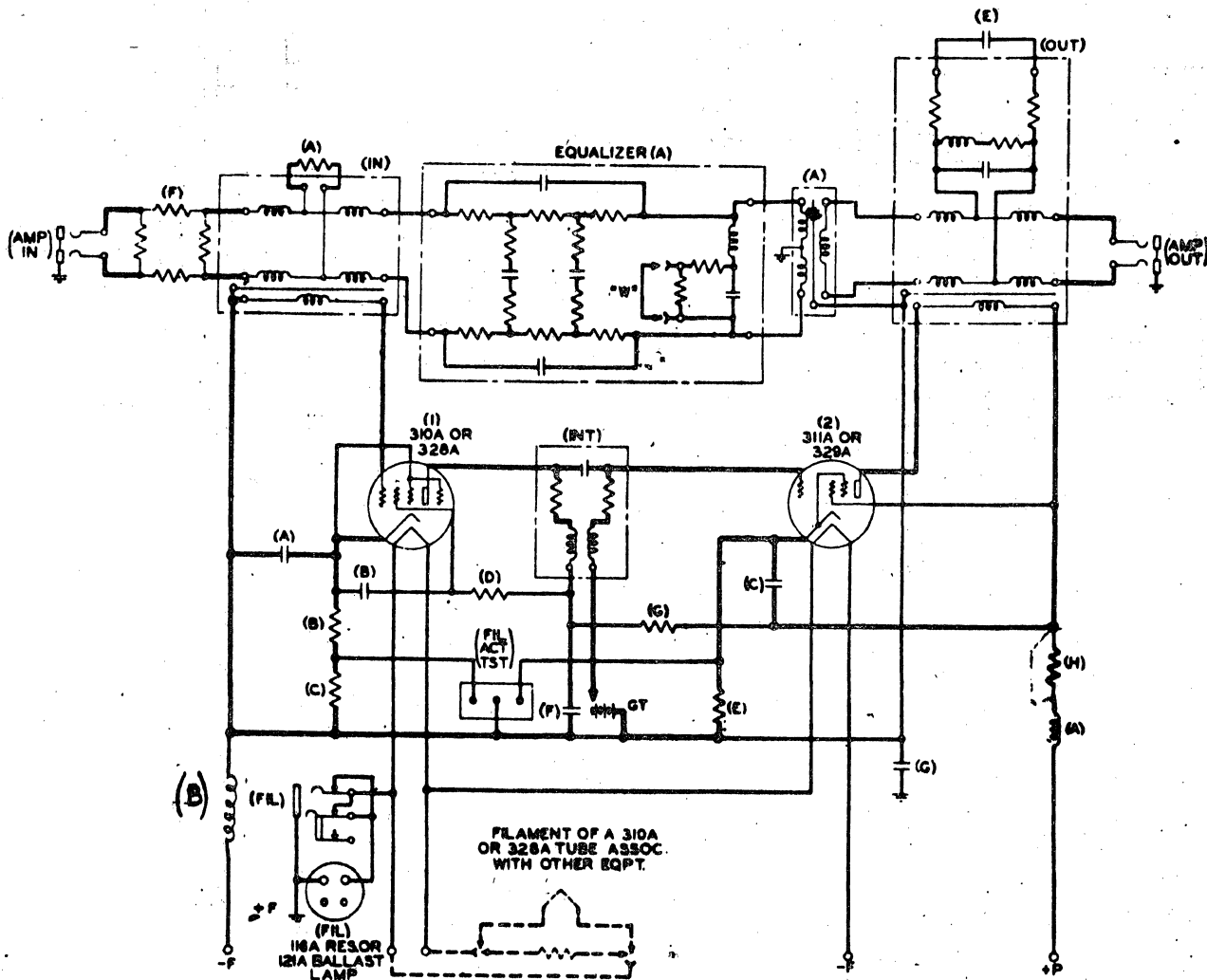

Fig. 6-6 - Amplifier Schematic

The equalizer is designed to make the gain of the amplifier flat with frequency from 5 to 35 kilocycles. The gain can be made either 50 or 52 decibels, by means of soldered strap "W". A 50-db gain is used in repeaters. It is of interest to compare the above amplifier with the one used in the C4 and earlier systems, shown in Figure 6-7. It was a 2-stage, push-pull, nonfeed-back amplifier. The last stage consisted of four 104-type vacuum tubes. The whole amplifier used six tubes compared with the two tubes required by its more modern counterpart.

CHAPTER 6 TYPE "C" CARRIER SYSTEM

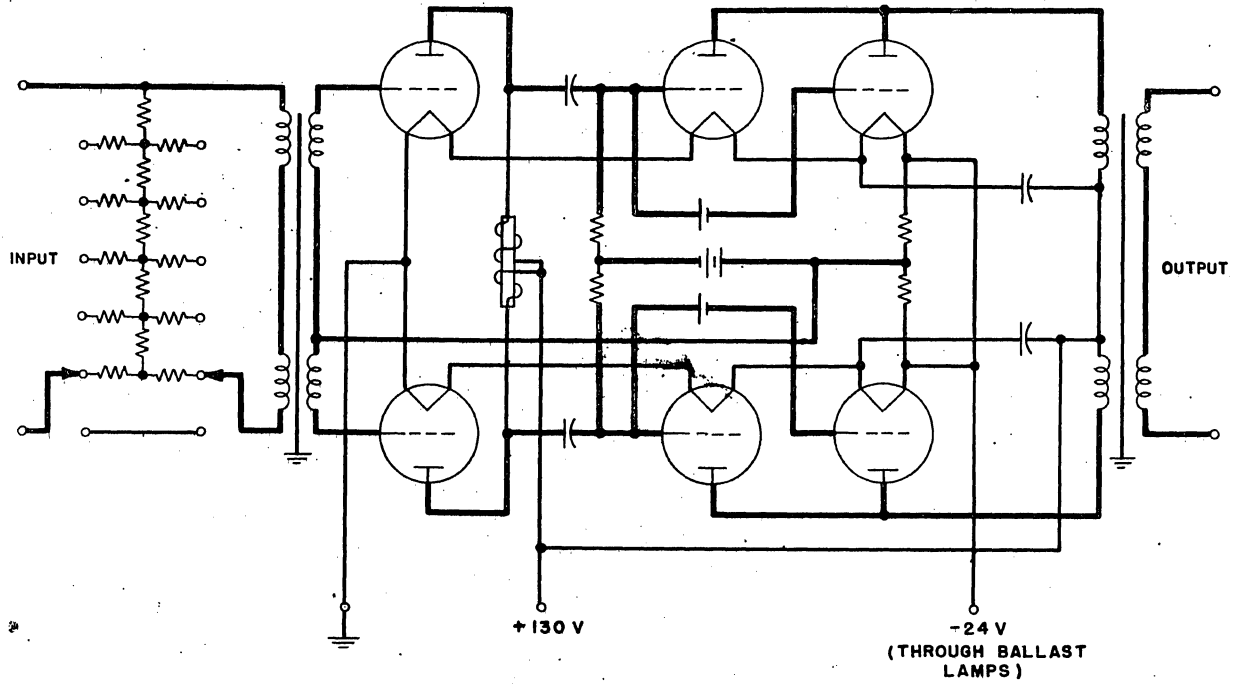

Fig. 6-7 - C4 System Terminal Amplifier Unit

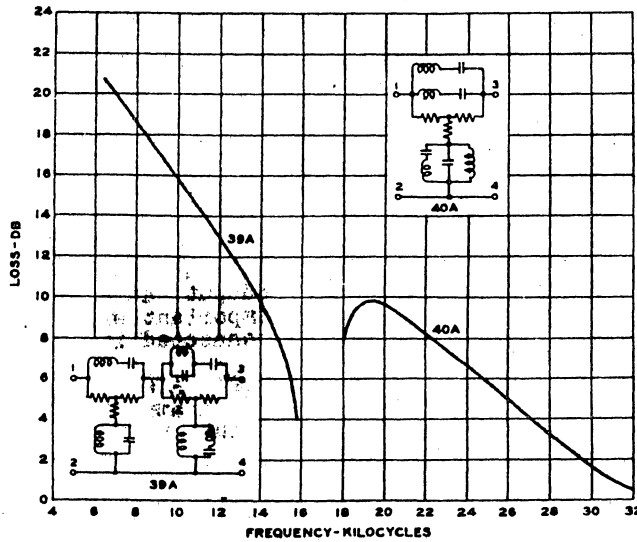

Fig. 6-8 - Typical Attenuation Frequency Characteristics of the Basic Equalizers

CHAPTER 6 TYPE "C" CARRIER SYSTEM

The repeater is normally operated at an output transmission level of +18 decibels. Pads are provided following the amplifier in each branch for decreasing the level if desired. Other pads are provided in the input of each branch which are used to build out the line loss of short line sections as required for optimum operation of the regulator. A "high cut-off filter" is connected, when necessary, in the W-E branch of the repeater to attenuate currents of frequencies above the C range. This prevents type "J" system crosstalk currents from circulating through type "C" repeaters, and also prevents the possibility of the type "C" repeaters singing at high frequencies. A "low cut-off filter" is connected in the output of the E-W branch to prevent low-frequency modulation products, generated in the repeater, from interfering with the voice-frequency telephone or program channel on the same line. Each branch of the repeater contains a basic equalizer which is designed to equalize the slope of a so-called maximum line section. The equalization is approximately correct for 270 miles of 165-mil, 12-inch spaced line, under wet weather conditions if DP insulators are assumed. For shorter line sections, the building-out networks shown in Figure 6-5 are added as needed. The loss characteristics of the basic equalizers in the two branches are shown in Figure 6-8. Auxiliary equalizers are sometimes required in addition to the basic equalizers. That in the W-E branch is to correct for the distortions introduced by the filters which separate type "C" and type "J" systems on the same pair or by the crosstalk suppression filters used on non-J pairs when other pairs on the pole line are equipped with type "J" systems. The auxiliary equalizer in the E-W branch similarly corrects for distortions caused by the 5000-cycle line filters when these are used to separate the type "C" and voice frequencies.

The regulator and regulating networks are part of the 2B carrier pilot channel equipment which is described below. All C1 repeaters include this equipment.

6.4 2B CARRIER PILOT CHANNEL

The 2B carrier pilot channel equipment provides for transmitting a pilot frequency adjacent to the middle channel of each one-way group, and includes regulators associated with all the repeaters and the receiving branches of the terminals for correcting for the variations in line attenuation due to weather and temperature. It functions in a manner similar to the type "J" regulating system.

The pilot frequency is generated by a single tube coil-and-condenser oscillator in which the amplitude of the oscillations is limited by a thyrite varistor. The automatic-gain-control circuit, which is actuated by the pilot at each repeater and the terminal, is shown in Figure 6-9. The pilot is selected by a filter bridged across the output of the line or receiving amplifier, is rectified, and then applied to the winding of a sensitrol relay.

CHAPTER 6 TYPE "C" CARRIER SYSTEM

If the level of the pilot deviates from its correct value by more than ± 0.5 decibel, the relay closes one or the other of its contacts, operating a motor geared to the movable plate of a multiplate capacitor associated with the regulating network. The movement is in such a direction as to change the loss of the regulating network so as to restore the pilot level to its correct value. The rate of correction is about one decibel per minute. The sensitrol relay (whose contacts are magnetically locked when closed) is automatically reset about every 4 seconds so that the motor will be stopped when it has made sufficient correction. An additional sensitrol relay operates alarms if the pilot level deviates $+3$ decibel or -5 decibel from its proper value.

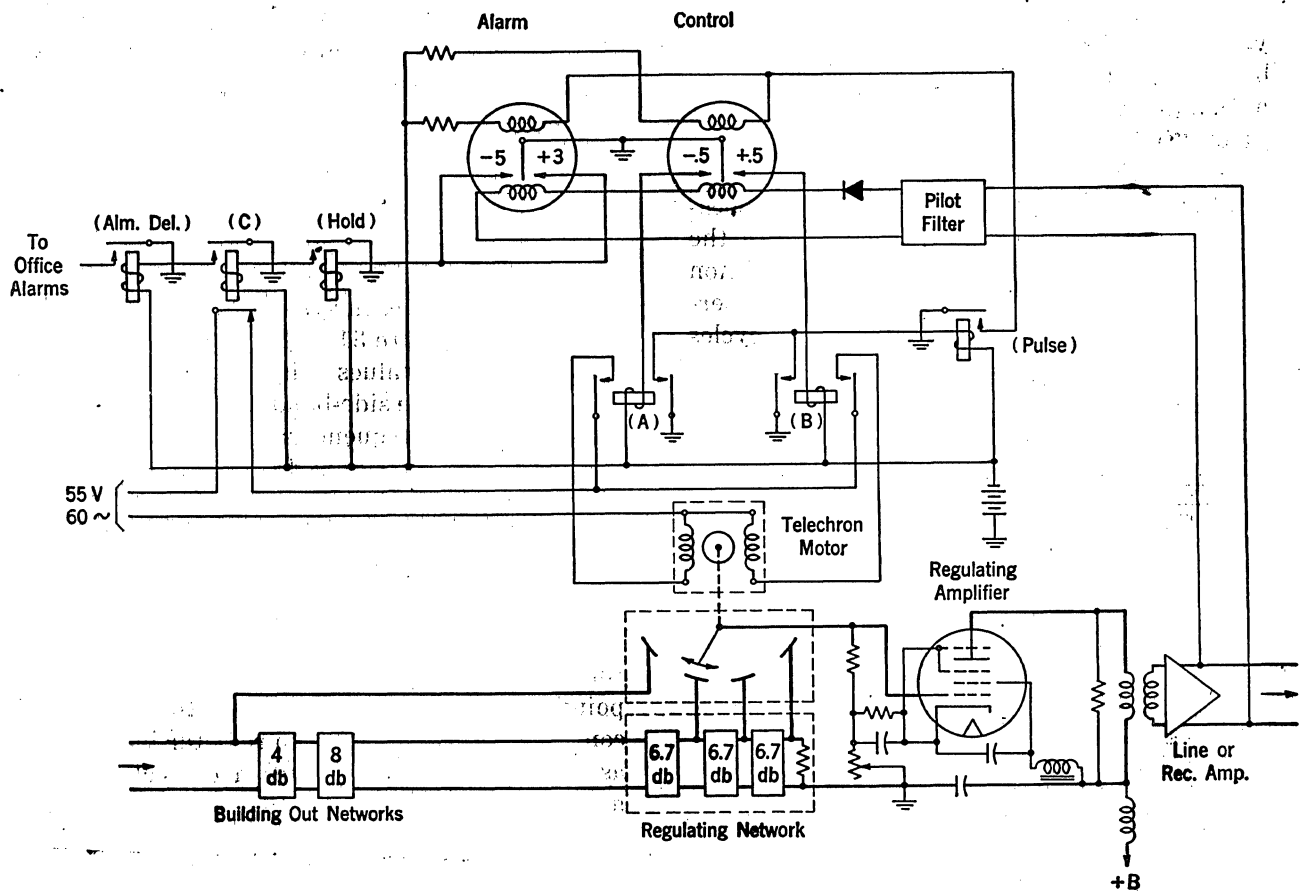

Fig. 6.9 - C - Carrier Automatic Gain Control Circuit

CHAPTER 6 TYPE "C" CARRIER SYSTEM

The regulating network consists of five sections, each having a characteristic inverse to a certain length of line. As a compromise, the networks are designed specifically to match sections of a 128-mil line equipped with CW insulators. Some small but not serious amounts of over- or under-compensation are therefore obtained on other types of lines. The method of connecting to the network sections through the moving plate of the multi-plate capacitor gives effectively a continuous, smooth adjustment over the entire available range. This range is 32 decibels at 15 or 28 kilocycles, respectively, for the low- or high-frequency groups of channels.

The regulator varies the slope as well as the loss. The regulating network includes a single tube amplifier, to provide a high impedance termination to the regulating circuit as well as to afford some needed gain.

The pilot frequencies are:

	<u>E to W</u>	<u>W to E</u>
CA	12.35kc	26.15kc
CB	12.35kc	23.25kc
CS	9.45kc	24.35kc
CU	9.45kc	21.45kc

If automatic regulation is not desired a potentiometer for manual gain regulation may be provided.

6.5 LINES

The above regulating arrangement is less complicated than that used for the type "J" system. The simpler arrangement is practicable for type "C" systems, first because rain and sleet affect the line attenuation less in the type "C" frequency range than at the higher frequencies used in the type "J" systems, and secondly because the type "C" system transmits a narrower frequency band than the type "J" system. The regulating system used in the type "C" systems which was just described assumes that the effect of rain and sleet, as well as temperature, on the line transmission is substantially equivalent to a lengthening or shortening of the line, within the range of frequencies that are transmitted in each direction.

Since toll entrance and intermediate cables appear in all open-wire lines, they must be taken into account in the engineering of type "C" as well as type "J" systems. When there is no type "J" system on the same pair with the type "C" system, the type "C" and voice frequencies are usually carried in the cables on ordinary paper-insulated twisted pairs having a special light loading suitable for the type "C" system frequencies.

CHAPTER 6 TYPE "C" CARRIER SYSTEM

Voice frequency telephone, D-C telegraph and type J carrier telephone may be used on the same pair with the C5 system as its frequency allocation is between the upper limit for voice circuits and below the band assigned for type J.

CHAPTER 7

TYPE "H" CARRIER SYSTEMS

7.1 GENERAL

The Western Electric H1 Carrier Telephone System (J68747) is a single-channel system which provides for superimposing an additional telephone circuit upon an existing voice-frequency telephone circuit working over an open-wire line. The carrier equipment includes provision for operation on a ringdown basis and can be applied on a line without the loss of any existing service. It is suitable for use as a permanent installation and also for temporary or emergency circuits. Without an intermediate repeater, the system will find its widest application on open wire circuits of about 25-200 miles in length; with one or two intermediate repeaters it will be applicable on circuits up to as much as 500 or 600 miles in length (depending on the gauge of the open wire conductors, the amount of intermediate cable in the line, the number of bridged way stations, etc.).

The H1 system employs copper-oxide modulators and demodulators, heater type pentode tubes, and improved filters made possible by new magnetic alloys. The copper-oxide varistors used as modulators, demodulators and rectifiers in the power supply are of smaller size than the customary vacuum-tube devices, have the advantage of long life and small power consumption, and provide better balanced and more stable modulation. A single heater-type pentode tube in the transmitting amplifier works at approximately the same output level as two tubes in the older systems. It simplifies the problem of working from 110-volt a-c supply by obtaining grid biases from across a resistance in the cathode circuit.

The terminal unit and the repeater may be operated either directly from a 115-volt 50-60 cycle alternating current source or from 24-volt and -130-volt and 130-volt batteries. This system employs the same carrier frequency, 7150 cycles, for both directions of transmission. The carrier frequency is generated locally at each terminal and only the sidebands are passed over the circuit. The upper sideband is used for transmission in one direction and the lower sideband for the other. Because of the relatively short distances over which the system is designed to operate, no equalization is provided and no automatic regulation of the circuit net loss is employed. However, for the longer systems a manual compensating adjustment has been included in each terminal whereby the receiving gain may be changed in three steps of 2 db each. Similar arrangements are also provided to control the gain of a repeater, two steps of 4 db each being provided. These adjustments will compensate for changes in loss due to weather and temperature changes in the line.

CHAPTER 7 TYPE "H" CARRIER SYSTEMS

It is necessary to compute and specify transmitting levels, repeater output levels, receiving levels, and circuit net loss for each H1 carrier circuit placed in service. This data should be based on the transmission performance of the carrier equipment and the characteristics of the open wire line and intermediate cable over which the system operates.

The type "H" carrier system is a successor of the discontinued type "D" system.

The frequency allocation of the type "H" system is shown in the lower part of Figure 6-1. It will be seen that although the same carrier frequency of 7150 cycles is employed for both directions of transmission, frequency separation of the oppositely directed channels is nevertheless obtained by the device of utilizing the lower sideband for the west-to-east and the upper sideband for the east-to-west transmission. The type "H" frequencies overlap those of the lowest channel of the type "C" systems, so that type "H" and type "C" systems cannot be applied to the same pair.

7.2 SIGNALLING

The type "H" system includes a 1000-cycle signalling system which is built into its terminals. The signalling current is generated by displacing the carrier frequency by 1000 cycles (upward for the east-west and downward for the west-east direction) and then interrupting the shifted carrier at a 20-cycle rate. The signalling currents thus generated, after demodulation in the receiving terminal, are identical with those of the standard 1000-cycle signalling system, and therefore will operate a standard ringer in a remote office to which the type "H" circuit may be extended over other types of facilities. Signal-receiving circuits are also built into the type "H" terminals for use when these coincide with the circuit terminals. The built-in signaling circuits are arranged to operate from and into the d-c or 20-cycle signaling arrangements which are standard in the various types of toll switchboards.

7.3 SYSTEM ARRANGEMENT

In designing the type "H" equipment, it was made as small and inexpensive as possible, consistent with obtaining the desired performance. An idea of the compactness that was achieved can be obtained from the fact that five complete type "H" terminals can be mounted in one 11-1/2-foot bay.

The general arrangement of a nonrepeated type "H" system as applied to one side circuit of a phantom group is shown in Figure 7-1 and 7-5. It will be seen that the carrier system is connected to the line at a point between the phantom repeating coil and the telegraph composite set. The voice and carrier channels are separated by line filters consisting of a low-pass filter in series with the voice circuit and a high-pass filter in the input to the

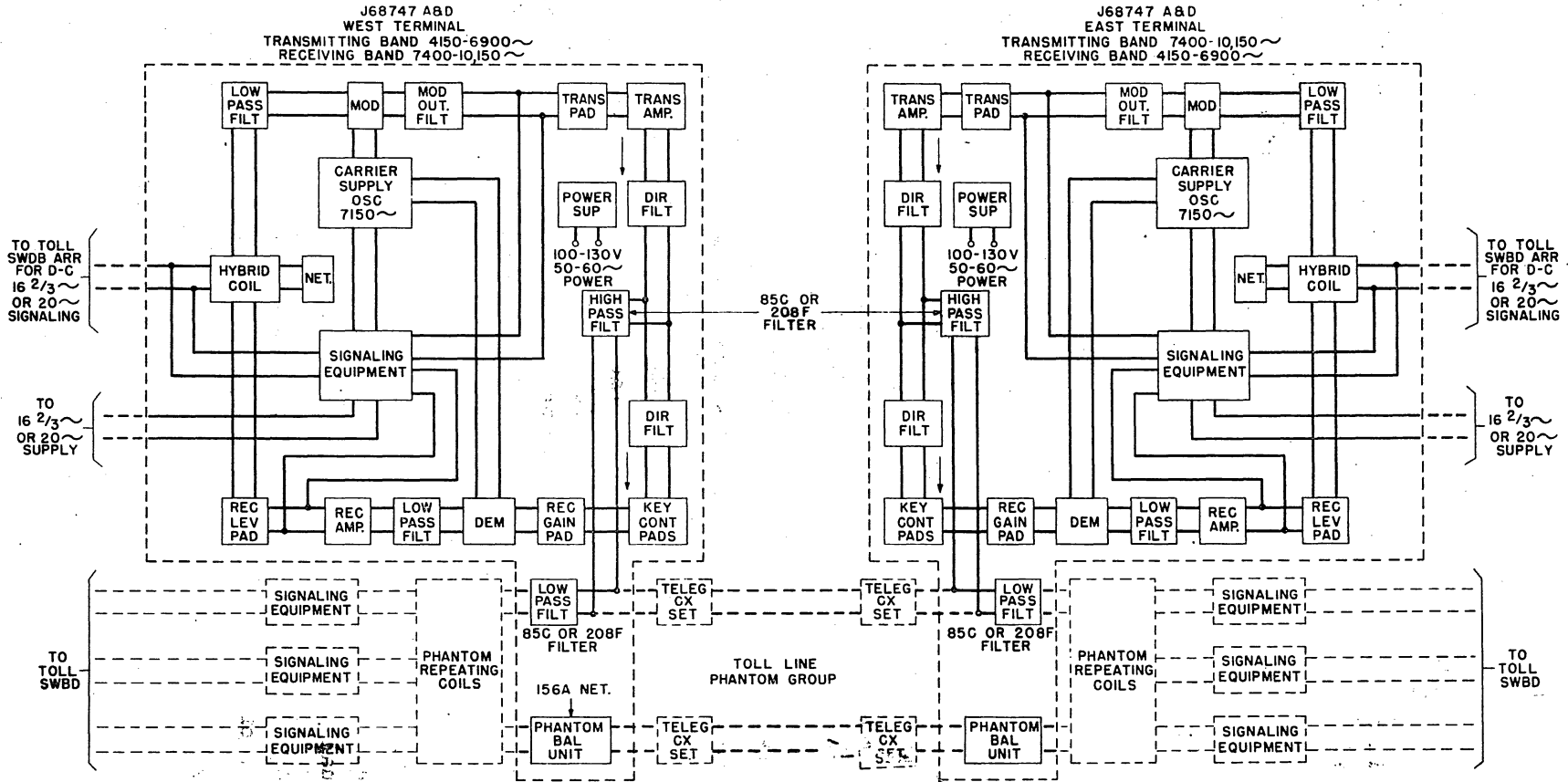

Figure 7-1 - General Schematic of an H1 Carrier Telephone System Without Intermediate Repeater

CHAPTER 7 TYPE "H" CARRIER SYSTEMS

carrier terminal. The insertion of the carrier line filter in one side circuit of a phantom group requires that a similar impedance be added to the other side circuit, in order to preserve the phantom balance and prevent undue crosstalk between the phantom and side circuits. A special balancing unit coded the 156A network is employed for this purpose. It is, of course, not required if both side circuits are equipped with type "H" systems.

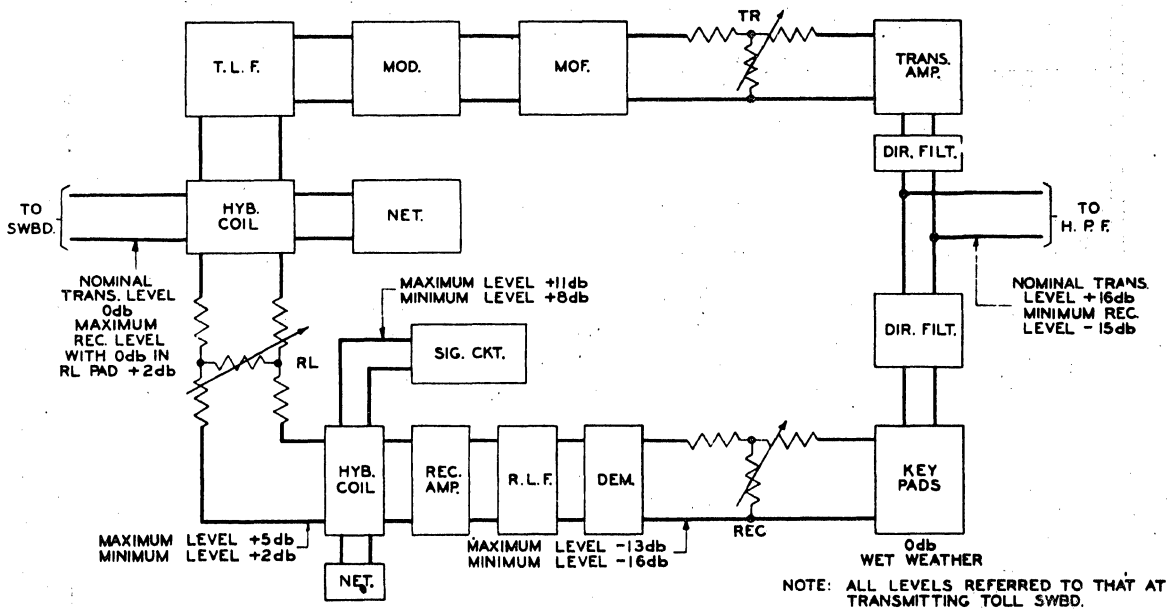

Figure 7-2 - Nominal Transmission Levels for H1 Terminal

CHAPTER 7 TYPE "H" CARRIER SYSTEMS

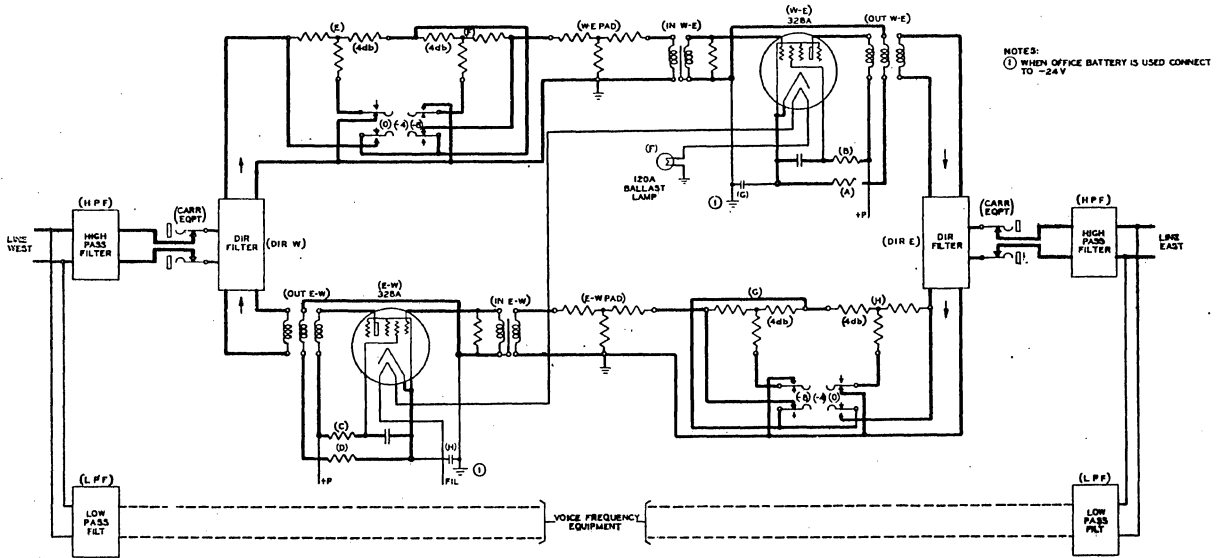

Figure 7-3 - Schematic of Repeater

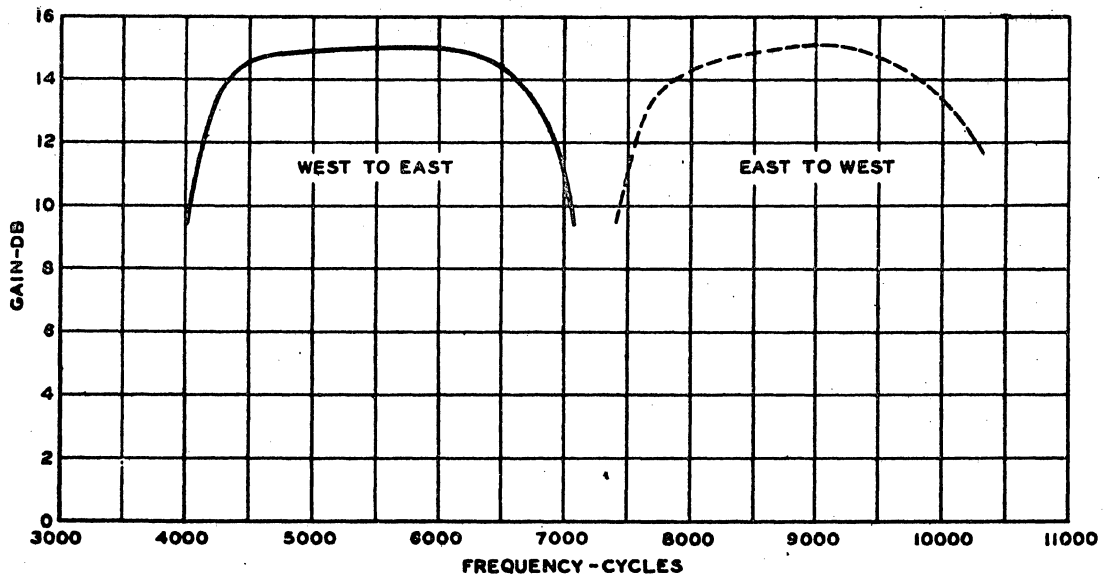

Figure 7-4 - Representative Gain-Frequency Characteristic of Repeater--30 db Loop Gain

CHAPTER 7 TYPE "H" CARRIER SYSTEMS

7.4 "H1" TERMINAL

A simplified diagram of the essential transmission features of a type "H" terminal is shown in Figure 7-2. It begins with the usual hybrid coil or 4-wire terminating set for separating the 2-way speech circuit coming from the switchboard into an outgoing and an incoming one-way branch. The upper, transmitting branch of the terminal, after passing through a filter to remove noise and speech frequencies that fall above the useful voice-frequency band, is applied to a lattice-type copper oxide modulator. This is supplied with a carrier of 7150 cycles frequency and 2.5 volts amplitude. The upper or lower sideband is selected by the succeeding filter, depending upon whether this is an east or a west terminal. Finally, the selected sideband is passed through a transmitting gain pad and the transmitting amplifier, and thence through a directional filter to the line. The transmitting amplifier is a single-tube, negative feed-back, fixed-gain amplifier. The gain pad is adjustable by soldered straps and is normally set so as to obtain a transmission level of +16 decibels on the line.

The incoming signals from the distant terminal are separated from the outgoing signals by the directional filters. They then pass through three pads to the demodulator. The first two pads may be cut in or out by keys, and have losses of 2 decibels and 4 decibels, respectively. These provide manual adjustments for compensating for the variations in the line attenuation. The third pad is adjustable by soldered straps and is set to obtain the desired receiving gain for the particular line on which the system is to be operated. The demodulator is a copper oxide modulator like that used in the sending branch. The voice-frequency band from the demodulator is selected by a filter and is then amplified by the receiving amplifier. This is a single-tube feed-back amplifier whose output transformer is arranged so as to form an asymmetric hybrid circuit. One of the conjugate outputs of the hybrid coil goes to the receiving signaling circuits, the hybrid loss in this path being 1.5 decibels. The other conjugate output (hybrid loss 7.5 db) carries the voice channel through two adjustable pads (called "receiving level" pads) to the terminating hybrid coil of the system. The pads, one of which is adjustable by straps in steps of 0.5 decibel from 0 to 3.5 decibels, and the other in steps of 4 decibels from 0 to 28 decibels, provide means for setting the over-all net loss of the carrier circuit to its desired value.

7.5 "H" CARRIER REPEATER

A repeater is available for extending the translation range of the H1 system. A schematic diagram of the repeater is shown in Figure 7-3. The amplifier tubes and circuits employed in the repeater are the same as those utilized for the high-frequency amplifier at the terminal. The repeater panel also includes directional filters, manually adjustable gain control pads, and an alternating current power supply unit.

CHAPTER 7 TYPE "H" CARRIER SYSTEMS

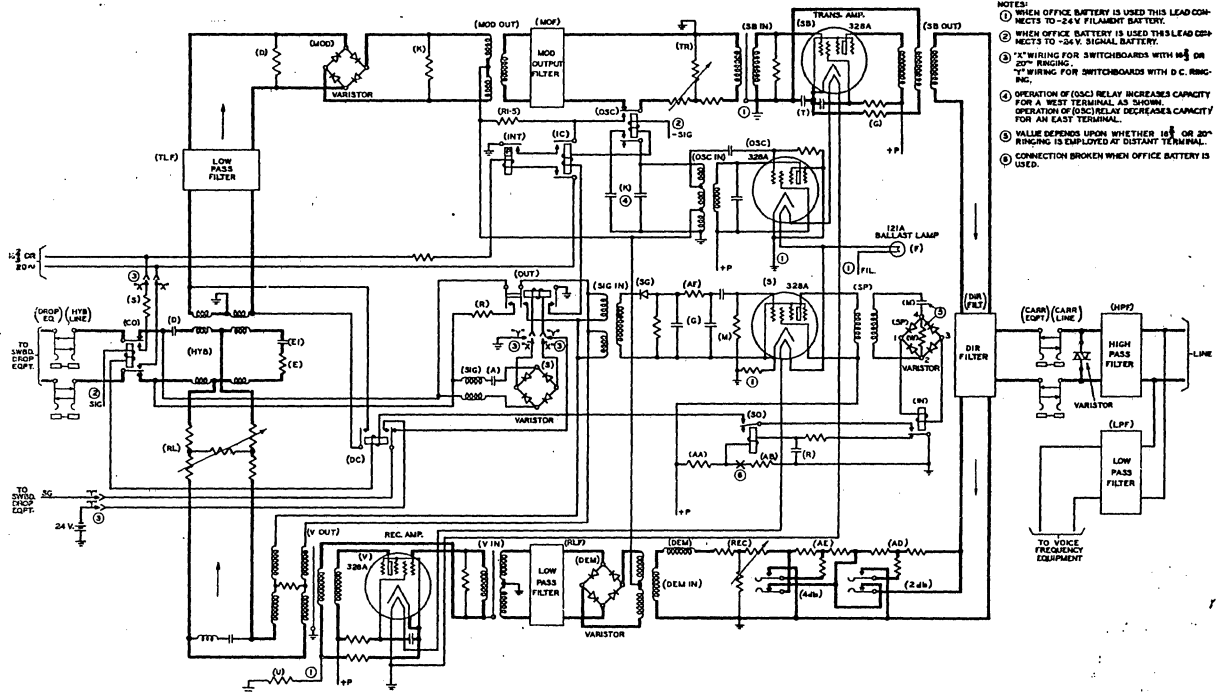

Figure 7-5 - Schematic of Terminal Transmission and Signaling Circuits.

The repeater consists of two -1 way paths, each containing a single stage feedback amplifier. Carrier enters directional filter on a 2 wire basis where it is routed to proper amplifier (E-W or W-E). No signalling arrangements are necessary at the repeater as signalling currents merely pass through, in a similar manner as the transmitting sidebands.

CHAPTER 7 TYPE "H" CARRIER SYSTEMS

7.6 "H" CARRIER TRANSMISSION

The transmission levels in the terminal circuits are also indicated in Figure 7-2. As noted earlier, the output transmission level sent into the line is nominally +16 decibels relative to the toll switchboard. The minimum receiving level on which the terminal will work is -15 decibels. This would seem to indicate that the system could work over any line whose maximum loss does not exceed 31 decibels, but as discussed later this is subject to some qualification. The demodulator itself is designed to work on a nominal input level of -13 decibels. This level must be kept above a minimum of -16 decibels for the signal receiving circuits to work properly. The pads ahead of the demodulator must be adjusted to compensate for the loss of the actual line so as to obtain the required level at the demodulator.

Since nothing designed by man is ideally perfect, there is not an infinite loss between the output of the transmitting branch and the input of the receiving branch of the terminal because of slight but finite transmission through the directional filters, and because of crosstalk coupling between the two branches. The carrier currents that thus leak into the receiving branch are there demodulated against the same carrier frequency which was used in the modulator and therefore reproduce the same voice frequencies that were applied to the sending branch. The leakage of the high-frequency currents between the two branches, plus the transmission across the voice-frequency hybrid due to unbalance between the compromise network and the line from the switchboard, therefore, create a round trip path in which there may be circulating currents. This places a limit on the permissible sum of the gains in the two branches (called the loop gain of the terminal), just as the hybrid coil unbalances limit the sum of the gains in the two directions of a 2-wire telephone repeater. The gain of the sending branch is fixed, since the output level is constant. The gain of the receiving branch is dependent on the sum of the losses in the receiving gain pads ahead of the demodulator and in the receiving level pads which follow the receiving amplifier, all other parts of the circuit being constant. Therefore, it is evident that the sum of the losses in the two sets of pads must be kept above some minimum value if the permissible maximum loop gain of the terminal is not to be exceeded. Now it can be seen that the greater the loss of the line, the smaller must be the loss in the receiving gain pads (to obtain the requisite level on the demodulator) and the greater, therefore, must be the loss of the receiving level pads if the loop gain limit of the terminal is not to be violated. Since the receiving level pads determine the net loss of the circuit, it is apparent from this reasoning that the minimum net loss at which the circuit can be worked is a function of the loss of the line.

The above general explanation can be reduced to the simple working rule expressed by the equation,

$$N = L - 22 \quad (7-1)$$

where,

CHAPTER 7 TYPE "H" CARRIER SYSTEMS

N = minimum allowable net loss of the carrier circuit

L = maximum attenuation of the line (wet weather) at 8150 cycles
(line frequency corresponding to a voice frequency of 1000 cycles
on the east-west channel)

Evidently if the line loss L has the maximum value of 31 decibels, the net loss of the circuit must be at least 9 decibels, while if the line loss were only 22 decibels, the circuit may be worked at a net loss of 0 decibel. This rule applies to the net loss of the carrier circuit from terminating set, even though switching pads are added on the switchboard sides of the terminating sets.

Little need be said about the transmission characteristics of the lines, since the type "H" system employs no equalization and only manual flat-gain regulation. It may be noted that the wet-weather loss of 104-mil open-wire lines at 8150 cycles is 0.11 decibel per mile. The problem of toll entrance and intermediate cables is often encountered, just as in the case of the type "J" systems. When loading is required on these cables, the BH-15-15 loading system is used. The Y-9 loading system is employed for office wiring.

The type "H" carrier system furnishes a telephone channel whose band is 250 to 3000 cycles or better, measured at the 10-decibel loss points. Representative transmission-versus-frequency characteristics for a type "H" system on a 100-mile 104-mil line having 3 miles of No. 19 gauge, BH-15-15 loaded toll entrance cable, are given in Figure 7-4. For a 200-mile circuit, the variation in loss between dry and wet weather may be in the order of 5 decibels. The manual adjustment provided in the terminals permits holding the variations in over-all net loss to ± 1 decibel. When a type "H" system is operated over lines less than 75 miles long, the manual adjustments are not required and the gain pads are ordinarily strapped out. A type "H" system may be operated on the same pole line with other carrier systems.

CHAPTER 8

A5 12-CHANNEL BANK

8.1 GENERAL

The A5 channel bank supersedes the A1, A2, A3, and A4 channel banks. It differs from former type "A" channel banks in the following respects:

- (1) It has been reduced in size to permit mounting at least nine banks in a 11' 6" bay as compared with three A4 channel banks.
- (2) It employs a three-stage transistor amplifier to replace the one tube demodulator amplifier. This permits greater stability with respect to battery variations, lower harmonic distortion which eliminates the need for an applique unit for telephoto service, and less susceptibility to induction noise.
- (3) It requires only -24 volt battery supply.
- (4) The modem units for each channel are physically and electrically identical and therefore interchangeable.

Single sideband program circuits may be operated over type J, K, or L carrier channels. As with other type "A" channel banks, this type of operation requires the removal of two message circuit channels (Channels 6, 7) for 5KC circuits or three message channels (Channels 6, 7, and 8) for 8KC circuits.

Over-all schematics of the A5 bank, including patching jack equipment and 4-wire terminating equipment are shown in Fig. 8-1.

The 2-wire voice frequency of each channel is connected through a hybrid coil which separates the transmitting and receiving circuits. In the transmitting circuits of the channel bank, the twelve voice-frequency bands are modulated with twelve carriers, ranging from 60 to 108 kilocycles at 4KC intervals. Twelve crystal-type band filters select the lower sidebands from the output of the modulators, which are of the suppressed-carrier type. The twelve sidebands are then combined in a single broadband spectrum from 60 to 108KC, and from this point are treated as a unit in subsequent steps of modulation, transmission over a line, and demodulation up to the point where they enter the receiving circuits of the far-end 12-channel bank. Here they are separated by twelve crystal-type receiving band filters and demodulated individually with locally-supplied carriers. Figure 8-2 shows the basic modulation plan.

8,2

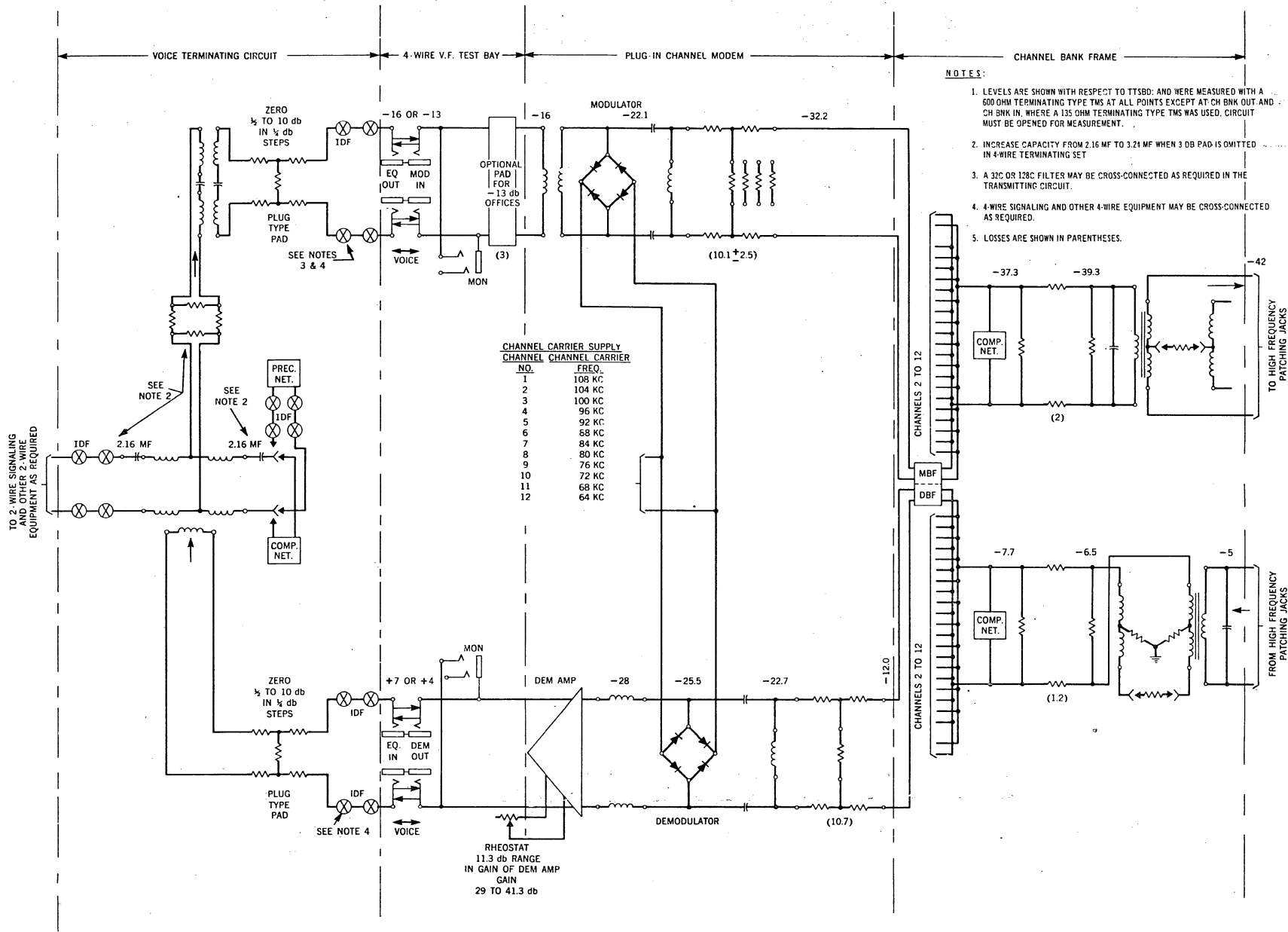

CHAPTER 8 A5 12-CHANNEL BANK

Fig. 8-1 - Over-all Schematic of A5 Channel Bank

CHAPTER 8 A5 12-CHANNEL BANK

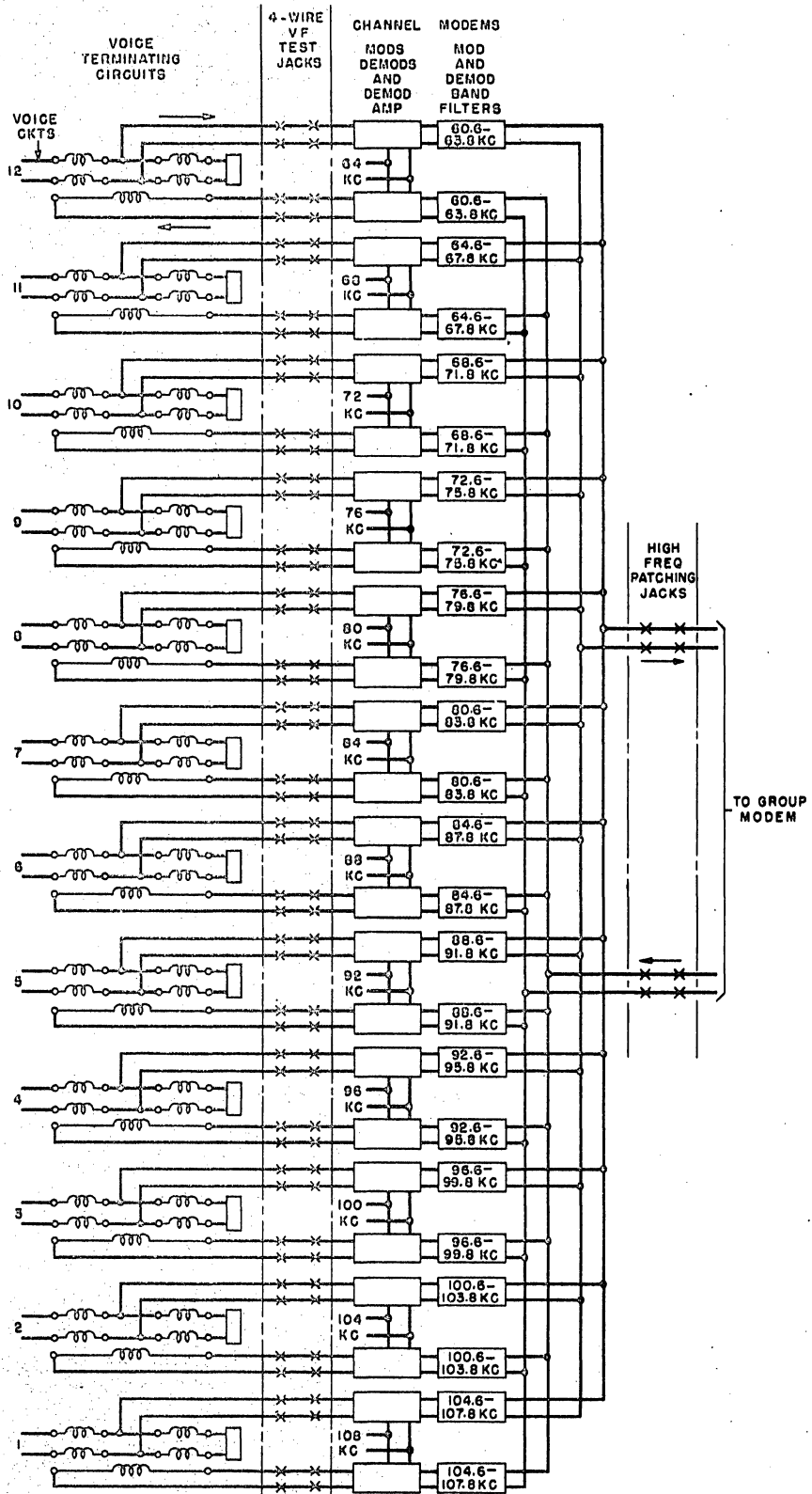

Figure 8-2 Frequency Plan

CHAPTER 8 A5 12-CHANNEL BANK

The A5 channel bank has approximately the same standards of bandwidth, output limitation and noise as the preceding A-type banks. In addition, it is less susceptible to hum pickup, has greater transmission stability, particularly with respect to battery variations, and has a lower temperature coefficient of gain variation than the A4 channel banks. The A5 demodulator amplifier exhibits a marked improvement in intrachannel modulation over previous type A demodulator amplifiers. Telephoto may be transmitted over the A5 channel bank without any modifications. The A5 is normally wired for a -16 db MOD IN level. Therefore, for offices using a -13 db MOD IN level a 3 db pad is required for each channel. This pad is located in the voice-frequency patch bay. The DEM OUT level encompasses both the +4 and +7 db levels by adjustment of a gain control in the voice-frequency patch bay. Modulator loss variations are corrected by an adjustable pad as discussed below.

8.2 DESCRIPTION OF CIRCUITS

The A5 channel bank is in general, interchangeable with the A1-, A2-, or A4-type banks in both operation and performance. The theory of the A5 channel bank operation is shown diagrammatically in Figs. 8-3 and 8-4 and is discussed in the following paragraphs.

Modulator Circuit

As indicated in Fig. 8-3 and 8-4, the voice-frequency currents enter the channel modulator at the MOD IN jacks. A 3 db pad is optionally provided in the voice-frequency patch bay and is used only in offices using a -13 db MOD IN level. The voice currents enter the modulator circuit through the input transformer. This transformer performs two functions: (a) it acts as a low-pass filter to attenuate spurious carrier frequencies from entering the modulator and (b) it insures a well-balanced modulator circuit.

Varistor Modulator: The voice-frequencies of each channel are modulated with one of the channel carrier frequencies as indicated in Fig. 8-2, producing sum and difference frequencies of carrier and voice-frequencies in the varistor modulator. The varistors are not adjustable and it is expected that they will not require replacement during the life of the equipment. The particular bridge arrangement of varistors employed in the modulator and also the demodulator circuits has a high degree of balance, and is sufficiently stable so that the carrier leak appearing in the output is relatively small. It is expected that the amount of this carrier leak from any modulator will not exceed -20 dbm at a zero level point for the A5 banks. In the average case, it should be considerably below this value. The modulator provides load limitation. This fact is taken advantage of in the design of amplifier equipment associated with the various broadband carrier systems. The limiting action takes place in the following manner: The carrier voltage applied to the modulator is of a much higher magnitude

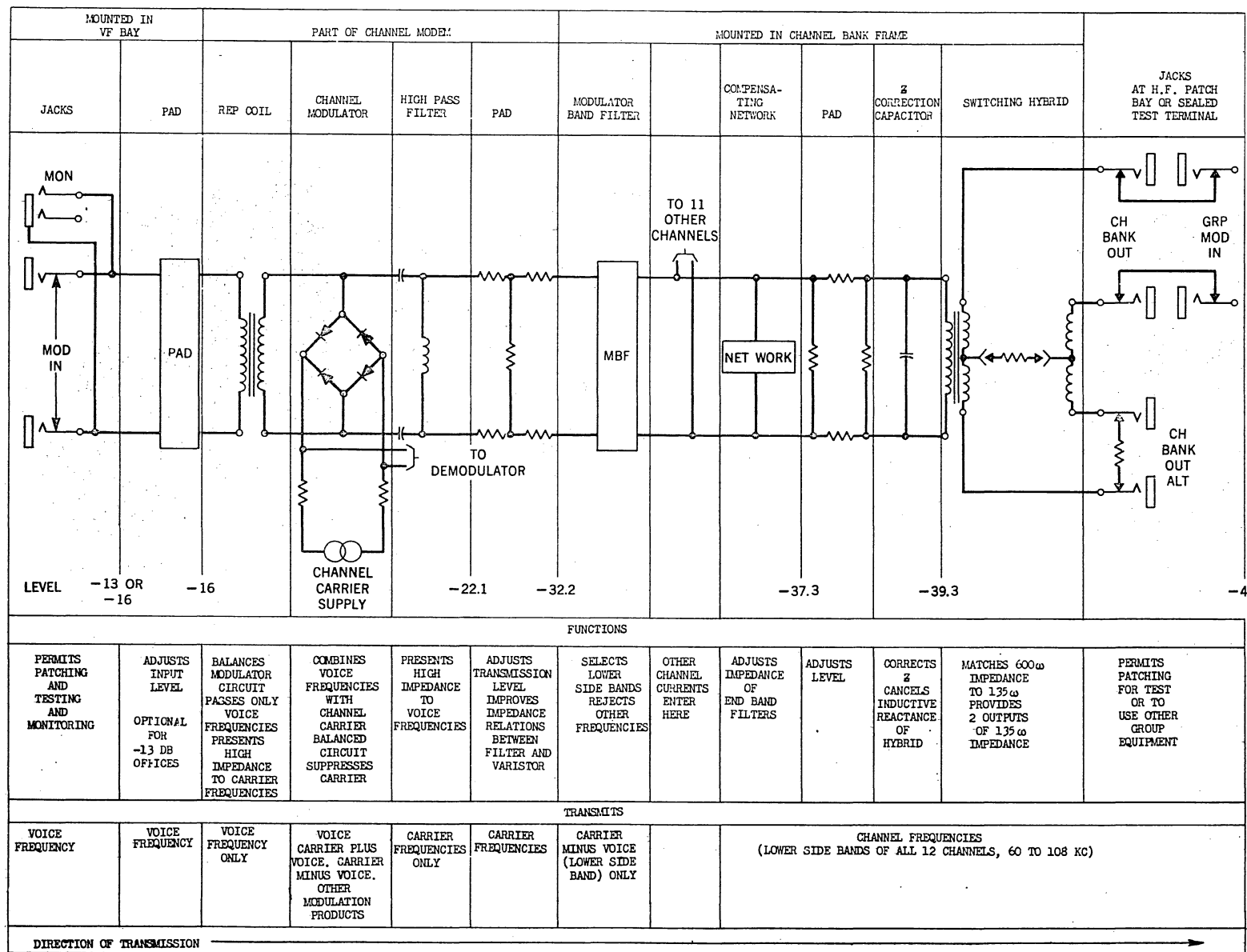

Fig. 8-3 - Simplified Schematic of Type A5 Channel Modulator

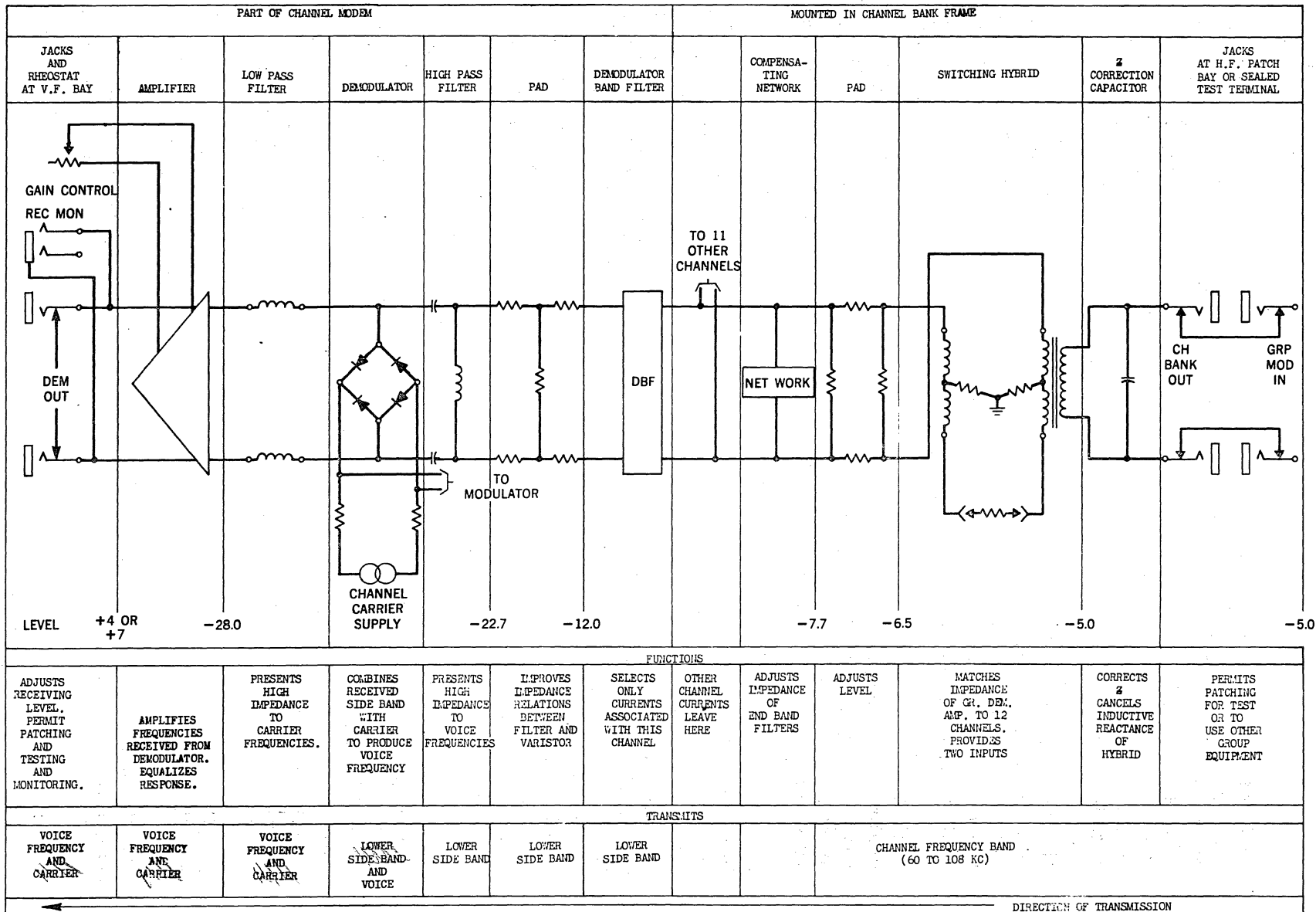

Fig. 8-4 - Simplified Schematic of Type A5 Channel Demodulator

8.6

CHAPTER 8 A5 12-CHANNEL BANK

than the average magnitude of input voice currents. For such a condition the output of the modulator is largely controlled by the magnitude of the voice-frequency voltage. When the input voice currents increase in magnitude, the output of the modulator increases linearly up to a point where the output compresses from the linear relationship. This condition occurs when the magnitude of the voice-frequency currents approaches the magnitude of the carrier. Any further increase in the voice-frequency voltages will then produce a smaller and smaller increment in the output of the modulator until a point is reached where the voice-frequency currents will no longer produce a change in output. One could consider this as a condition where the effect of the voice and the carrier voltages on the modulator are reversed. The carrier supply for both modulators and demodulators is obtained from a common carrier supply.

High-Pass Filter: A half-section high-pass filter is provided in the A5 channel bank between the modulator proper and the resistance pad. This filter presents a high impedance and attenuation to the voice-frequency signals appearing at the output of the modulator and offers very little attenuation to the desired carrier sideband signals.

Resistance Pad: A resistance pad of approximately 10 db for the A5 bank is provided between the modulator and the modulator band filter. This pad reduces the interaction between the modulator and band filter and attenuates the carrier sideband signals, providing a means by which the modulator circuit loss may be adjusted to meet performance requirements. This pad is adjustable over a range of +2.5 db in 0.3 db steps to permit the output of each channel to be adjusted to the same level (usually at the output of the transmitting amplifier). Grounds are placed at the midpoint of the shunt resistance of the pads and at the midpoint of the 600-ohm winding of the transmitting hybrid transformer to balance the circuit for the operation of the crystal band filter. This is an important adjunct in obtaining the high suppression to unwanted frequencies.

Band Filters: The varistor modulator produces the usual two (upper and lower) sidebands and the lower one is selected by the crystal channel band filter. Since in this portion of the modulator circuit a frequency range of 60 to 108KC is involved, filters of the crystal type are particularly suitable. In addition, this type of filter permits a wider transmitted band for a given channel spacing, a more uniform attenuation over the band for a given transmission loss, and a smaller and more compact assembly than could be obtained with the coil and capacitor type of filter.

The 561-type filters used in the A5 channel bank differ mechanically from previous channel bank filters, in that the transmitting and receiving filters are packaged in a single container. The electrical design of these filter units, however, is the same as that of the 536-type and 219-type which are used in the A4 and A2 channel banks, respectively. The filter units consist

CHAPTER 8 A5 12-CHANNEL BANKS

of only one lattice section; however, there are two crystal units connected in parallel in each lattice arm. 31E-type crystal units and 1509-type ferrite inductors comprise the major component apparatus. Although both filter units are mounted on a common chassis, the judicious placement of shielding devices has resulted in crosstalk suppression consistent with present design objectives. A schematic and representative frequency characteristics are shown in Figs. 8-5 and 8-6. The entire assembly is packaged in a drawn steel container and is hermetically sealed. The approximate over-all dimensions are 4-7/32" by 2-23/32" by 5-7/32" not including terminals and mounting studs.

Impedance Transformation Circuit: A 485A compensating network is bridged across the common side of the modulator band filter circuit to improve the transmission characteristics of the upper and lower channels. Without the compensating network, the channel transmission frequency characteristic on the end channels (Channels 1 and 12) is likely to have unwanted slopes and rounded instead of sharp corners at 200 (Channel 1) and 3400 cycles (Channel 12). Associated with the modulator band filters and this compensating network is a 600 to 135 + 135-ohm hybrid transformer. This transformer provides a 600-ohm balanced impedance for the operation of the band filters, and matches the 135-ohm balanced circuit of the group modulator circuit. One of the 135-ohm outputs feeds the regular group modulator while the other appears at the CH BANK OUT ALT jacks. The second output is provided to facilitate switching a working bank to other apparatus without interruption.

Demodulator Circuit

Impedance Transformation Circuit: The operation of the demodulator circuit is similar in general principle to that of the modulator circuit. The 60 to 108KC band making up the 12 channels enters the receiving side of the circuit through an impedance matching transformer and compensating network (see Figs. 8-1 and 8-4). The impedance matching transformer is a hybrid transformer having an impedance ratio of 135 to 600 + 135 ohms. This transformer provides a second output which can be used for switching to a carrier program terminal or other equipment. When this latter feature is not required, the winding is terminated in 135 ohms.

Band Filters: The demodulator band filters select the individual 4KC lower sideband for each of the 12 channels in the 60 to 108KC range. Each of these individual bands is transmitted from its respective filter to its associated demodulator circuit. As indicated above, the demodulator and modulator band filter characteristics are equivalent for the same channel.

Resistance Pad: The 10.7 db resistance pad in the demodulator circuit is used between the demodulator band filter and the demodulator to present a good impedance to the demodulator band filter, and terminate the demodulator band filter. Unlike previous channel banks, adjustment is not needed

CHAPTER 8 A5 12-CHANNEL BANKS

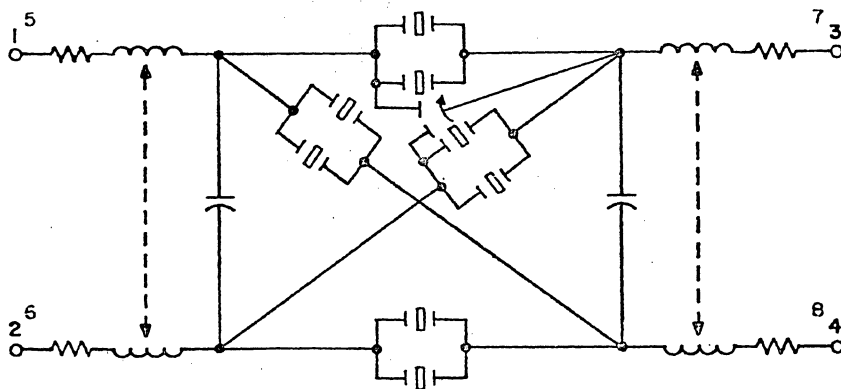

Fig. 8-5 - Schematic of 561 Filter

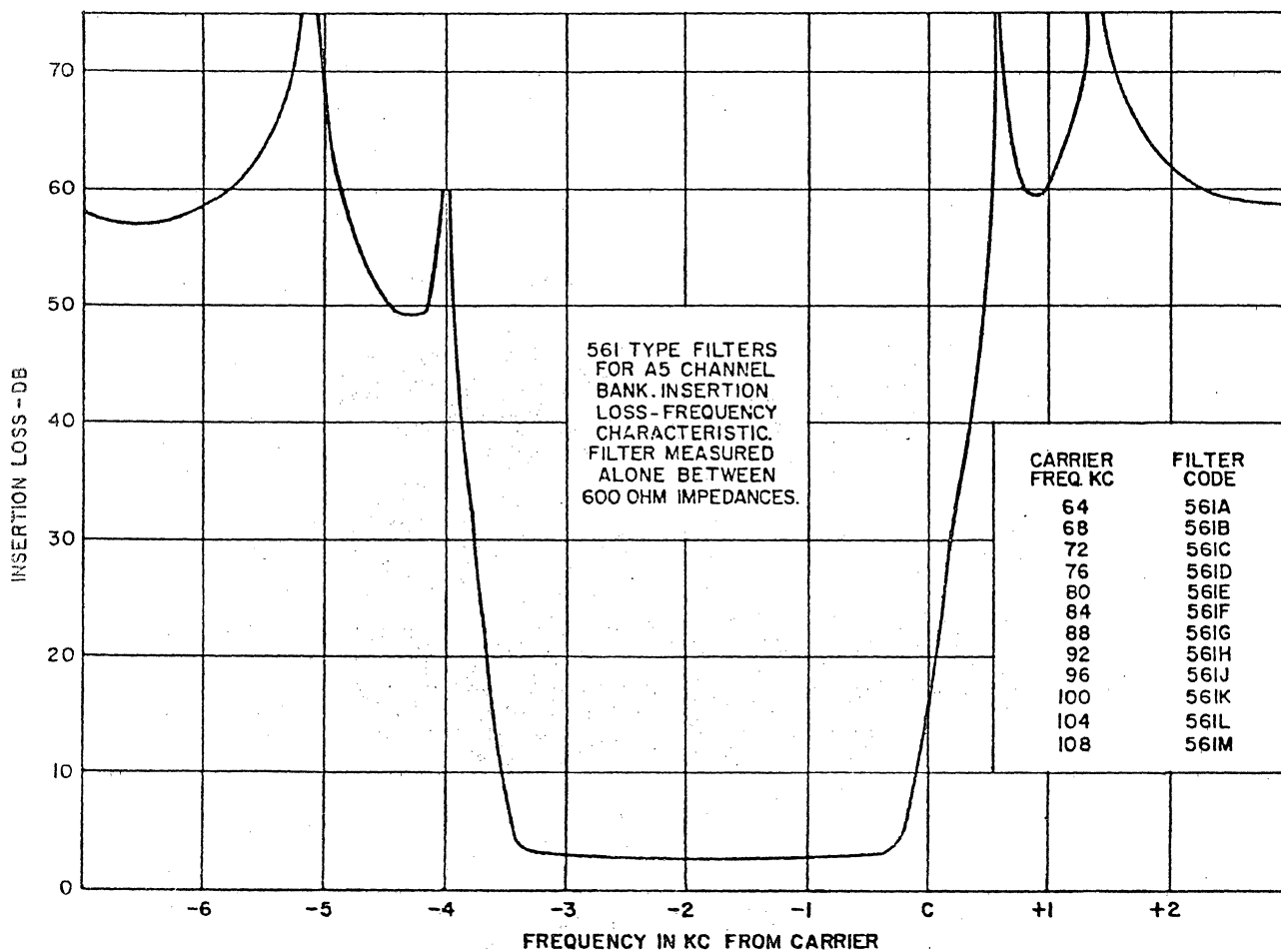

Fig. 8-6 - Frequency Characteristic of 561 Filter

CHAPTER 8 A5 12-CHANNEL BANKS

in this pad, since the demodulator amplifier gain control suffices for an adjustment to either the +4 db or +7 db level at the DEM OUT jack without degradation of performance.

High-Pass Filter: The half-section high-pass filter between the resistance pad and the varistor demodulator serves the same purpose as a similar filter in the modulator circuit. It effectively reduces the loss of the demodulator by about 4 db through a better impedance match.

Demodulator: In each demodulator the 4KC carrier frequency band is demodulated with the channel carrier frequency. The modulation products consist of both the upper and lower sidebands. The demodulator is identical with the modulator but it is poled oppositely on the carrier supply so that dc components of modulation in the modulator and demodulator neutralize each other and thereby avoid developing an undesirable voltage bias. The poling also reduces somewhat the amount by which stray frequencies have to be suppressed in the carrier supply.

Demodulator Amplifier: The voice energy resulting from the modulation of received sideband energy with carrier enters the demodulator amplifier through the input transformer. This input transformer isolates dc currents of the demodulator varistor circuit from the amplifier. Voice currents are passed to the three-stage transistor amplifier consisting of Q1, Q2, and Q3 as shown in Fig. 8-7. The portion of the output signal appearing at the emitter of Q3 is fed back to the emitter of transistor Q1 for stabilizing the gain of the amplifier. A shaping network is provided in this feed-back path to compensate for the 200 cps increased loss due to the band filters. Output transformer T2 isolates and balances the amplifier and terminates the collector circuit of transistor Q3 in the 600-ohm balanced voice circuit. The gain of the demodulator amplifier is adjusted by variation of a 950-ohm potentiometer located at the voice-frequency patch bay. This potentiometer serves to control a portion of the feed-back signal and allows the gain to be varied over a range of approximately 12 db, a typical demodulator amplifier providing a gain of approximately 29 to 41 db. Supply voltage from the demodulator amplifier is central office filtered battery, -24 volts. Current drain for each modem is 66 +6 milliamperes dc. Total current drain for the complete A5 channel bank with twelve modem units installed is approximately 792 +20 milliamperes dc.

Due to the wide range of the amplifier, carriers in the 60-108KC range are present at the DEM OUT jacks at a level approximately 25 db below signal level. Excessive leak may indicate a poor balance in the demodulator circuit.

CHAPTER 8 A5 12-CHANNEL BANKS

8.3 TRANSMISSION FREQUENCY CHARACTERISTICS

Fig. 8-8 shows a 12-channel average transmission frequency characteristic of an A5 prototype channel bank. The 485A impedance transformation network and a shaping network in the demodulator amplifier provide the necessary equalization for each channel. In all A-type channel banks, the equalization provided serves to correct for two similar filters, one transmitting and one receiving. Consequently, when one type of bank is used at one terminal (either transmitting or receiving) and another type is used at the other terminal, the equalization provided by this feature may be slightly degraded at the edges of the band (200 and 3200 cps). When the A5 is used with an A2- or A4-type channel bank, there is no degradation; when used with A1 or A3 there is slight degradation since the filter characteristics are somewhat different at the band edges. It is therefore desirable, where practicable, to assign A5 channel banks so that they operate with other A5 channel banks or, when required, A2- or A4-type banks.

The bandwidth, measured at the points where the attenuation is 10 db higher than the attenuation at 1000 cycles, is about 3400 cycles. The upper and lower 10 db points fall at about 110 and 3500 cycles respectively for average temperature conditions. The effect of the 4-wire terminating set is to sharpen the cutoff below 200 cycles.

The modulator in the channel bank provides load limitation. A representative load characteristic of the modulator and demodulator is shown in Fig. 8-9. The modulator is the main contributor because it operates at a higher transmission level than the demodulator. It will be noted that normal volume speech is not appreciably affected by the limiting action; however, the peaks of very loud speech are effectively limited by the limiting action.

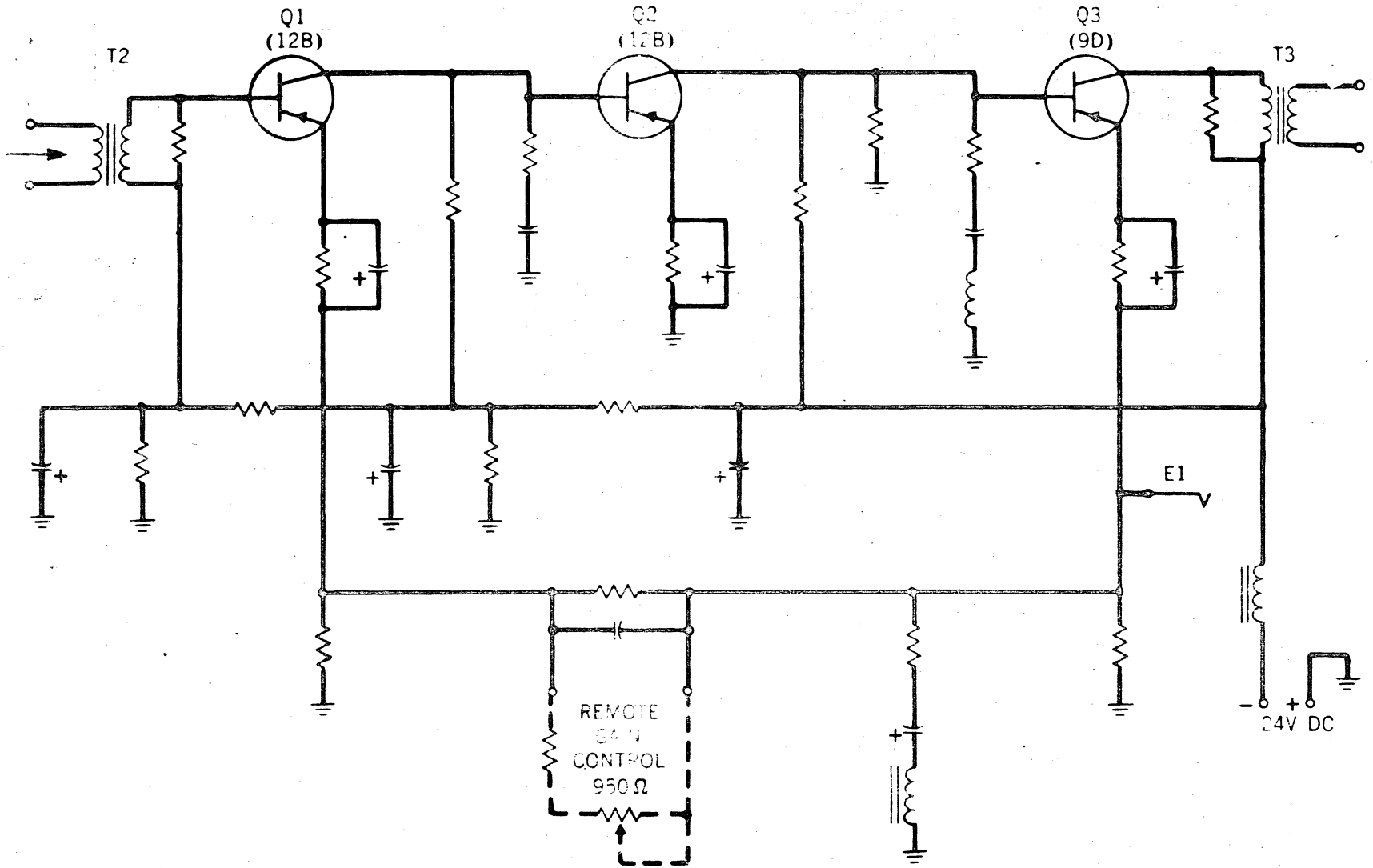

Fig. 8-7 - A5 Demodulator Amplifier

CHAPTER 8 A5 12-CHANNEL BANKS

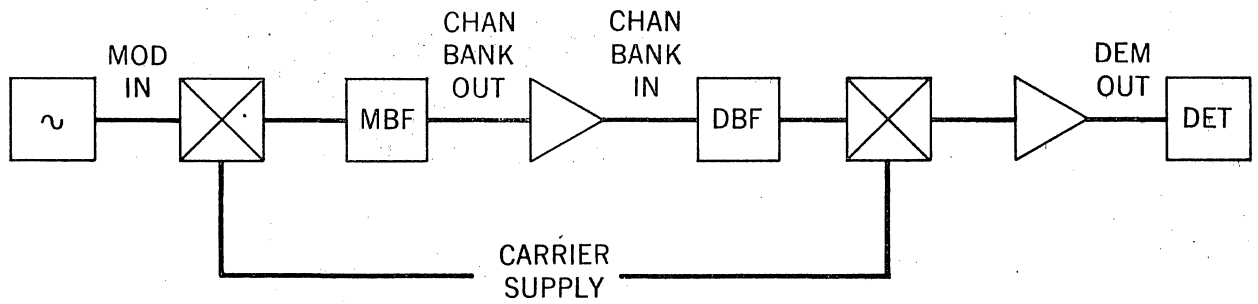
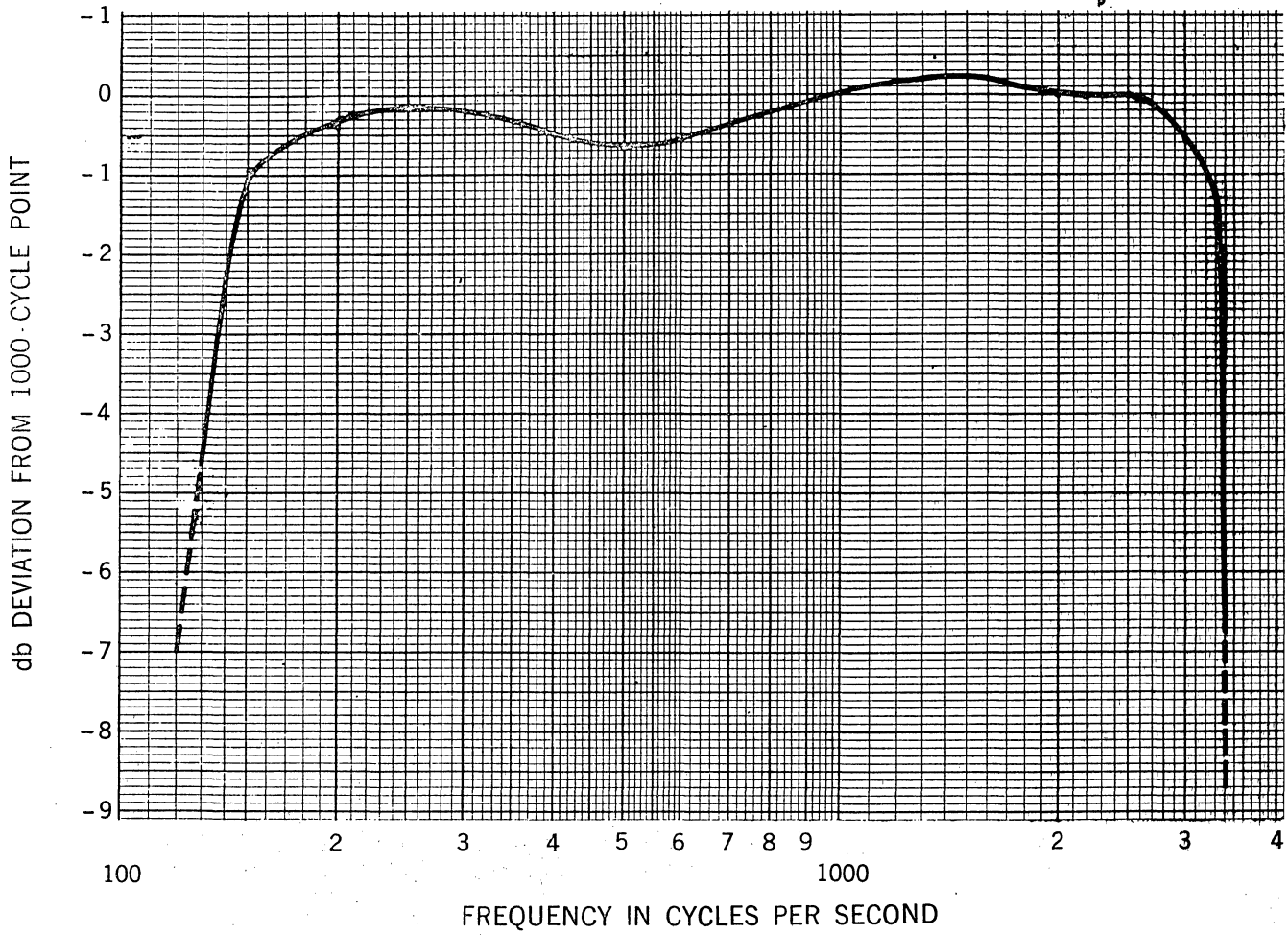
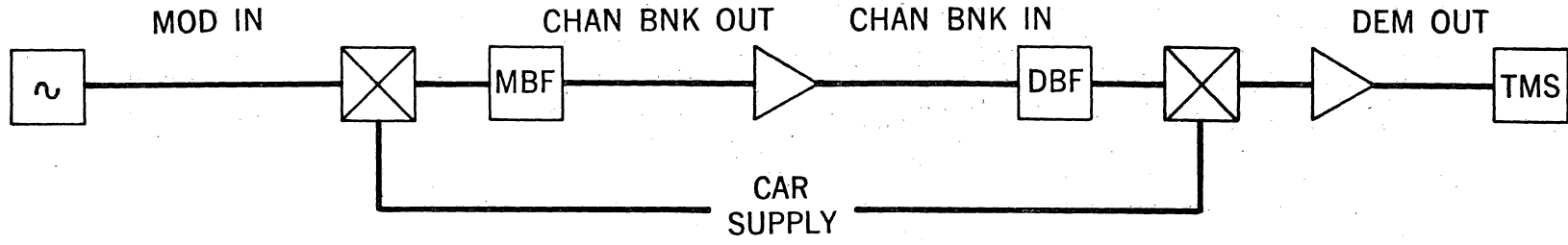

Fig. 8-8 - 12-Channel Average Transmission Frequency Characteristic



8.4

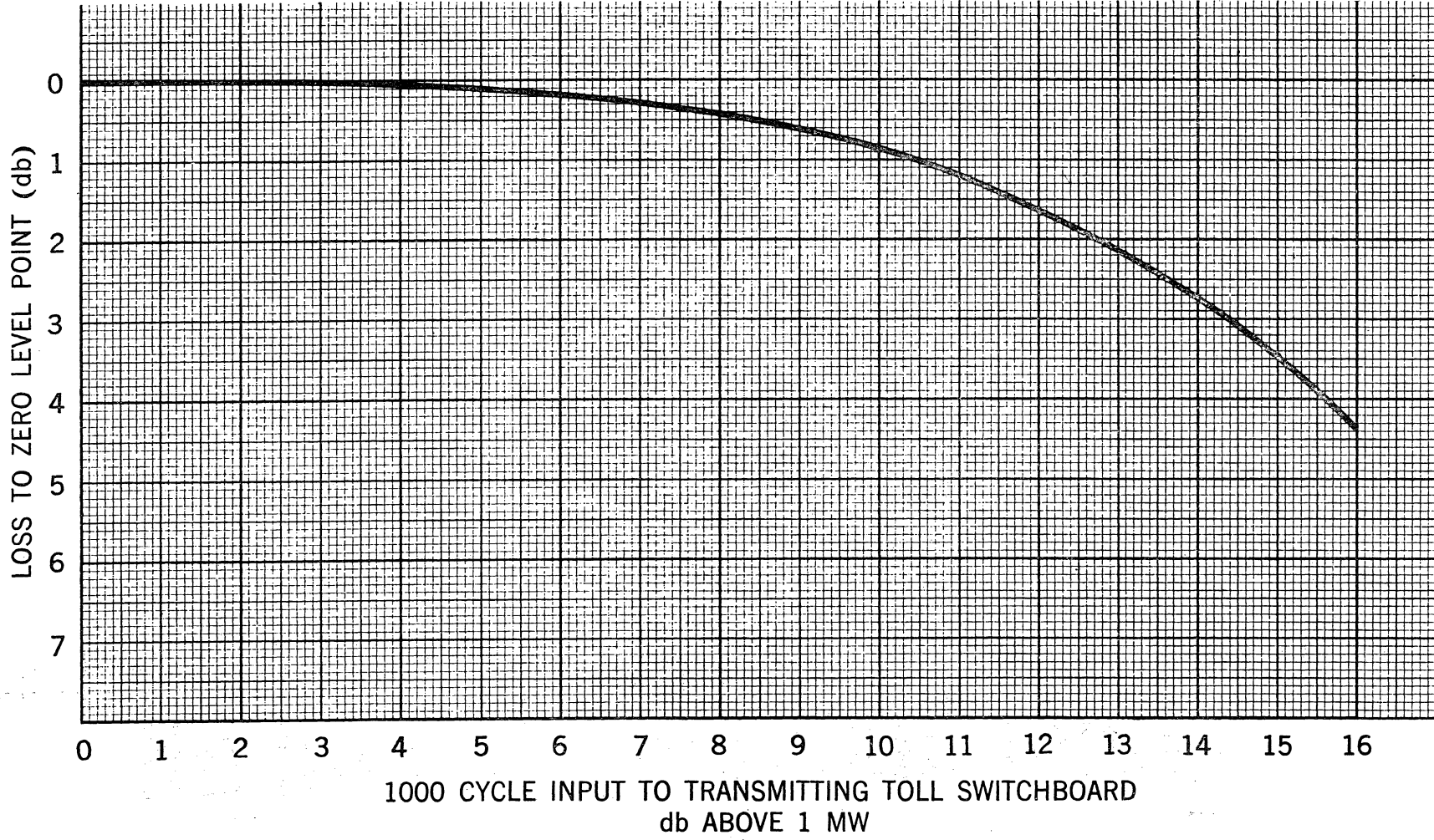

Fig. 8-9 - Load Characteristic of Modulator and Demodulator

CHAPTER 9

TYPE "J" CARRIER TELEPHONE SYSTEM

9.1 INTRODUCTION

This chapter describes the third one of the triumvirate of broadband carrier systems, the type "J" carrier system. This system provides twelve 2-way long-haul telephone channels on one open-wire pair, and has frequency allocations such that a type "C" carrier system and a voice-frequency system can also be operated on the same pair. Thus, with the advent of the type "J" system, one open-wire pair became capable of furnishing a total of sixteen 2-way telephone channels.

The development of the type "J" system began at about the same time as that of the type "K" and type "L" systems, and reached the stage of a field trial on a 250-mile line between Wichita, Kansas and Lamar, Colorado in 1937 and 1938. The initial system, known as the J1, had only one line pilot for each direction of transmission, for controlling the gains and slopes of the amplifiers. This was found to be inadequate under sleet conditions, which led to the development of the J2 system with two line pilots. Since practically all of the J1 systems have now been converted to J2, this chapter will describe only the J2 carrier system.

Although many of the techniques used in the type "J" system resemble those to be described for the type "L" and "K" systems, there are numerous differences due to the special character of the open-wire lines on which the type "J" systems are used. In the first place, the loss and the loss-versus-frequency characteristic of an open-wire line are much less stable than in the case of cable pairs of coaxial circuits, being affected not only by temperature but even more by other weather conditions, such as rain or sleet, from which cable conductors are protected by the cable sheaths. Secondly, open-wire pairs are wholly unshielded from surrounding electric and magnetic fields, whether due to radio waves, atmospheric static, neighboring power systems, or other telephone wires on the same pole line. These facts increase the severity of the regulation, equalization, noise, and crosstalk problems. These problems are solved by the use of suitably spaced repeaters which deliver high transmission levels to the line, by the system of equalization and regulation employed, and by the use of specially designed transposition systems on the line.

A third point in which open-wire lines differ from cable circuits is in their lack of homogeneity. Open-wire lines are no longer permitted to enter the streets of a city, and therefore the circuits must be extended from the environs of a city to a toll office in its center by means of "toll entrance"

9.2

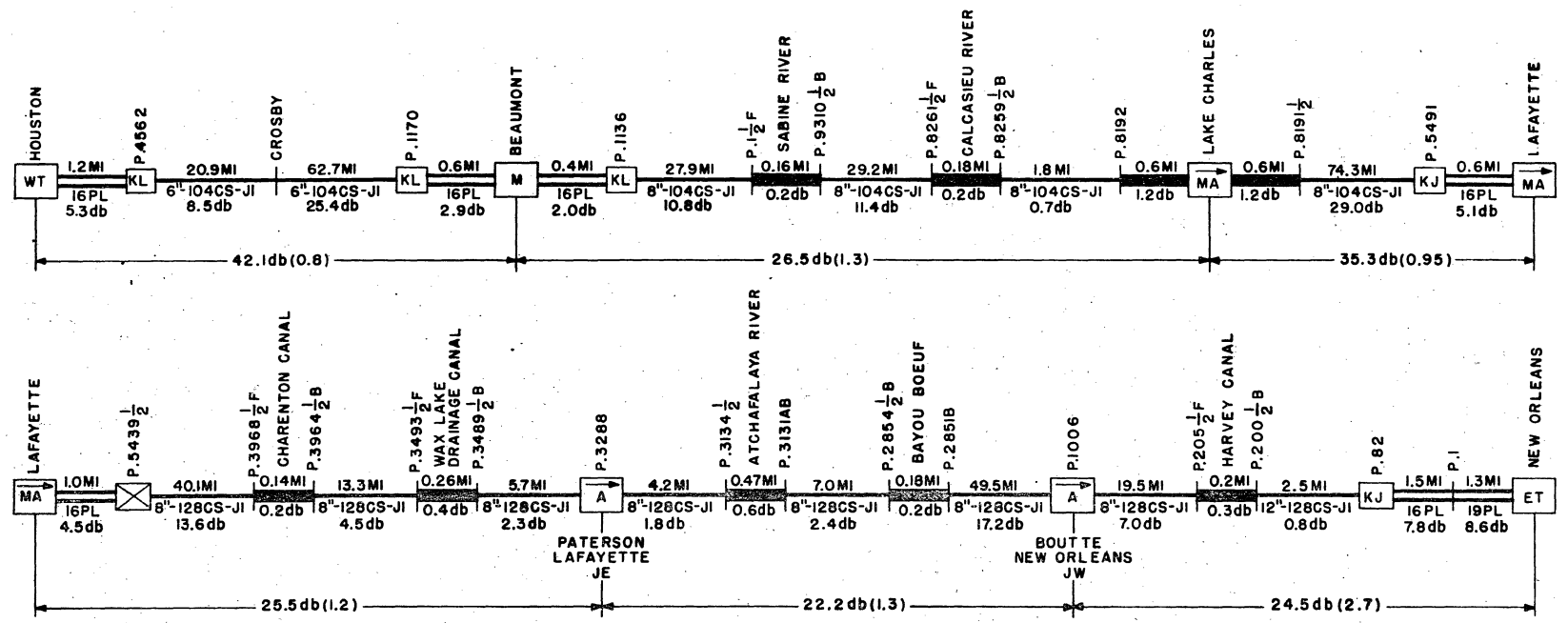

- | | | |
|---------------------------------------------------------------|--------------|-----------------------------------------------------------------------------------------------|
| WT WEST TERMINAL | CODE | — OPEN WIRE |
| ET EAST TERMINAL | | ▬ NONLOADED CABLE, PAPER INSULATED (PI) OR DISC INSULATED (DI) |
| M MAIN REPEATER | | ▬ LOADED DISC INSULATED CABLE |
| A AUXILIARY REPEATER | | G INDICATES G LOADING UNIT |
| MA MAIN REPEATER WITH AUXILIARY REPEATER CONTROL PANEL | | → DIRECTION OF TRANSMISSION OF ALARMS |
| ⊗ FILTER HUT WITH J CARRIER LINE FILTERS, ETC | | 8"-165CS-JI SPACING, GAUGE, INSULATION AND TRANSPOSITION DESIGN |
| KL J CARRIER LINE FILTER MOUNTED ON TERMINAL POLE | NOTES | |
| KJ CARRIER JUNCTION FILTER | 1 | ATTENUATION GIVEN AT 140KC FOR AVERAGE WET WEATHER AND ALSO MAXIMUM db PER MILE GIVEN IN (). |
| | 2 | LEAD IN CABLES NOT SHOWN UNLESS LONGER THAN 330 FEET. |

Figure 9-1 Type "J" Carrier Layout - Houston-New Orleans

CHAPTER 9 TYPE "J" CARRIER TELEPHONE SYSTEM

cables. Intermediate cable sections are also frequently used for river crossings. Thus, a long open-wire line always contains numerous short lengths of cable. This is illustrated in Figure 9-1, which shows the layout of a line between Houston and New Orleans. The cable sections must of course be arranged to transmit the type "J" carrier frequencies. This is done by using either ordinary nonloaded twisted pairs, or by means of special, usually loaded, spiral-4 conductors placed in the cables for that purpose, as described more fully in a later section.

Since open-wire conductors are unshielded from ambient electric and magnetic fields, open-wire lines cannot be made to furnish electrically isolated groups of pairs such as can be obtained by means of two cables on a cable route or by installing shields in a cable. For this reason, the two directions of transmission of an open-wire carrier system must be separated by the use of different frequencies rather than by the use of different conductors. In the type "J" systems, the west-to-east channels are transmitted in the lower part of the frequency range between about 36 and 84 kilocycles, and the east-to-west channels are transmitted in the upper part of the frequency range between about 92 and 142 kilocycles. The two oppositely directed groups of channels are sent on the same pair and are separated from each other by directional filters at each repeater point.

In order to reduce crosstalk between systems operating on the same pole line, the type "J" systems have been provided with four slightly different frequency allocations in the above general ranges. These are designated the JNA, JSA, JNB, and JSB systems.

In the terminals of a type "J" system, the twelve telephone channels handled by the system are modulated and combined to form a basic group of channels lying between 60 and 108 kilocycles, by the same channel bank which is used in the type "K" and type "L" systems. The basic group is translated to the desired frequency allocation on the line by group modulators that are different from those used in the other carrier systems, requiring two stages of modulation in the sending end and two stages of demodulation in the receiving end of the system. Since the basic group is alike in all the broadband systems, interconnection may be made between type "J" and type "L" systems or between different type "J" systems by patching the basic group, thus avoiding the necessity of reducing the channels all the way to voice frequencies in order to patch them.

The grade of transmission afforded by the type "J" system meets the standards for long toll circuits, except under extreme sleet conditions. The bandwidths of the channels are the same as for type "K" and type "L" systems. Under severe ice conditions, the equalization of the system may be impaired, and may even be unsatisfactory if the condition exists in several repeater sections. The transmission velocity over long single links is about 115,000 miles per second, including the effect of the filters

CHAPTER 9 TYPE "J" CARRIER TELEPHONE SYSTEM

in the repeaters and the terminals. The noise objective for average channels of type "J" systems is 29 dba at the -9-db transmission level, when an average 4000-mile connection consisting of five links is assumed. This value may be exceeded on the worst channels under severe static or sleet conditions.

The type "J" system will be described in somewhat greater detail in the remainder of this chapter. The features unique to the type "J" system will be emphasized. Those features involving techniques that have been described in the preceding chapters will be covered in less detail.

9.2 DESCRIPTION OF TYPE "J" TERMINALS

General Modulation Scheme - Frequency Allocations

The function of any carrier terminal is to translate the telephone channels handled by the system from voice frequency to their allotted frequencies on the line and vice versa, and to supply the required line pilots. In the type "J" terminals, three stages of modulation or demodulation are employed to perform the frequency translations. The first stage of modulation and the last stage of demodulation occur in the channel bank which, as stated earlier, is the same as that employed in the type "L" and type "K" systems. It converts twelve 2- or 4-wire telephone circuits from the toll switchboard into an outgoing and an incoming basic group of channels in the frequency range between 60 and 108 kilocycles.

The second stage of modulation and of demodulation occurs in a group modulator and a group demodulator which are the same for all type "J" carrier terminals. These perform the translations between the basic group frequencies of 60 to 108 kilocycles and a group lying between 400 and 448 kilocycles, using a carrier of 340 kilocycles. It is at this point, also, that the line pilots are introduced. The third stage of modulation translates the 400- to 448-kc band to its assigned frequency allocation on the line, and the first stage of demodulation* does the converse of this, translating the line signals to a band between 400 and 448 kilocycles. The carrier frequencies required here, of course, depend upon whether the terminal is an East or a West terminal and whether the system is a JNA, JSA, JNB, or JSB system.

As noted in Section 9.1, these designations refer to four slightly different frequency allocations, adopted to minimize crosstalk between type "J" systems on the same pole line. These allocations, and the corresponding carrier frequency required for the last group modulator at the sending end or the first group demodulator at the receiving end, are given in the table of Figure 9.2

*In this description, the term "modulation" is applied to the processes in the sending terminal and the term "demodulation" signifies the modulation processes in the receiving terminal.

CHAPTER 9 TYPE "J" CARRIER TELEPHONE SYSTEM

It will be noted that the frequency allocations for the west-to-east direction are the same for all four type "J" systems except that in two of them the channels are inverted. In the east-to-west direction the allocations are staggered in increments of one kilocycle, two of them being also inverted. The advantages of these allocations from the crosstalk standpoint will be discussed in a later section.

<u>System</u>	<u>West to East</u>		<u>East to West</u>	
	<u>Frequency Band</u> <u>on Line (kc)</u>	<u>Carrier</u>	<u>Frequency Band</u> <u>on Line (kc)</u>	<u>Carrier</u>
JNA	36-84 (U)	484 kc	92-140 (L)	308 kc
JSA	36-84 (L)	364	95-143 (U)	543
JNB	36-84 (U)	484	93-141 (U)	541
JSB	36-84 (L)	364	94-142 (L)	306

Note: (U) and (L) indicate whether the individual telephone channels appear on the line as upper or lower sidebands, that is, whether they are normal or inverted with respect to the original speech bands.

Figure 9-2 Frequency Allocations of Type "J" Carrier Systems

The terminal equipment must also supply the line pilots. The frequencies of the pilots on the lines are the same for all four of the type "J" allocations, and are 40 and 80 kilocycles in the west-to-east direction, and 92 and 143 kilocycles in the east-to-west direction. The 80- and 92-kc pilots are used for flat-gain regulation, while the 40- and 143-kc pilots are used for slope regulation as described later. The pilots are actually injected at the input to the first group modulator at such frequencies as to reach the line at the above frequencies after passing through the two group modulators. See Figure 9-1.

Description of Terminal Equipment - Refer to Figures 9-3, 9-12

With the above general information regarding the functions of the terminal equipment in mind, we may now examine in somewhat greater detail the arrangement of equipment that performs these functions. A block diagram of a type "J" terminal is shown in Figure 9-3. The 4-wire voice-frequency patching bay and the channel modem bay in the upper left of the figure are parts of the channel bank.

The channel bank is connected to the group terminal equipment through the normals of the high-frequency patching jacks. At these jacks, the signals are in the form of the basic channel group lying between 60 and 108 kilocycles, and have the transmission levels of -42 decibels in the transmitting direction and -5 decibels in the receiving direction. The nominal impedance at these jacks is 135 ohms.

CHAPTER 9 TYPE "J" CARRIER TELEPHONE SYSTEM

Group Transmitting Circuits

Figure 9-3 shows that the basic group from the channel bank, after passing through the high-frequency jacks, is routed through a band-elimination filter to the input of the first group modulator. At a west terminal the band-elimination filter attenuates two of the channel carrier leaks (64 and 104 kc) which might interfere with the two line pilots. At an east terminal, the filter attenuates all of the channel carrier leaks as a precaution against their introduction by crosstalk as fixed tones in the channels of adjacent staggered systems (type "J" systems having one or more of the other three allocations). The modulator itself is a lattice-type copper oxide modulator such as is shown in Chapter 6.

Figure 9-3 shows the line pilots, from the carrier and pilot channel supply equipment (lower left of Figure 9-3), being applied to the input of the first group modulator, as well as the channel group. The input of this modulator includes a hybrid circuit (not shown) and the channel group and the pilots are applied to the modulator through conjugate terminals of the hybrid circuit. As noted earlier, the carrier applied to the first group modulator is 340 kilocycles. The upper sideband of this modulation process, consisting of a band from 400 to 448 kilocycles, is selected by a coil-and-condenser type of filter for transmission to the second group modulator. Following the filter is a 2-stage feed-back amplifier with about 27.5-db gain to raise the level of the signals applied to the next modulator.

From the amplifier, the signals are applied to the input of the second group modulator which is also a lattice-type copper oxide modulator. The carrier frequency for this modulator is one of those listed in Figure 9-2, depending upon whether this is a west or an east terminal, and which of the four frequency allocations the system is to have. The modulator is followed by a low-pass filter of the coil-and-condenser type which attenuates all frequencies above about 150 kilocycles to remove unwanted high-frequency products of the last modulation process. Following the filter is a deviation equalizer which corrects for distortions introduced by the several filters in the transmitting terminal. At east terminals there is also a supplementary high-pass filter which attenuates unwanted products from the last modulator which are below about 90 kilocycles, to eliminate near-end crosstalk.

The group of line frequencies is amplified by a transmitting amplifier, which is considered a part of the terminal in the type "J" systems. This is a 3-stage feed-back-type amplifier having a flat-gain over the entire range from 36 to 143 kilocycles. The last stage of the amplifier consists of four 311A heater-type pentodes in parallel and delivers a level to the line +17 decibels with respect to the transmitting toll switchboard. The output of the amplifier is applied to the line by way of the transmitting side of a directional filter which separates the outgoing and incoming frequency groups. The nominal impedance at both the input and the output of the transmitting amplifier is 125 ohms.

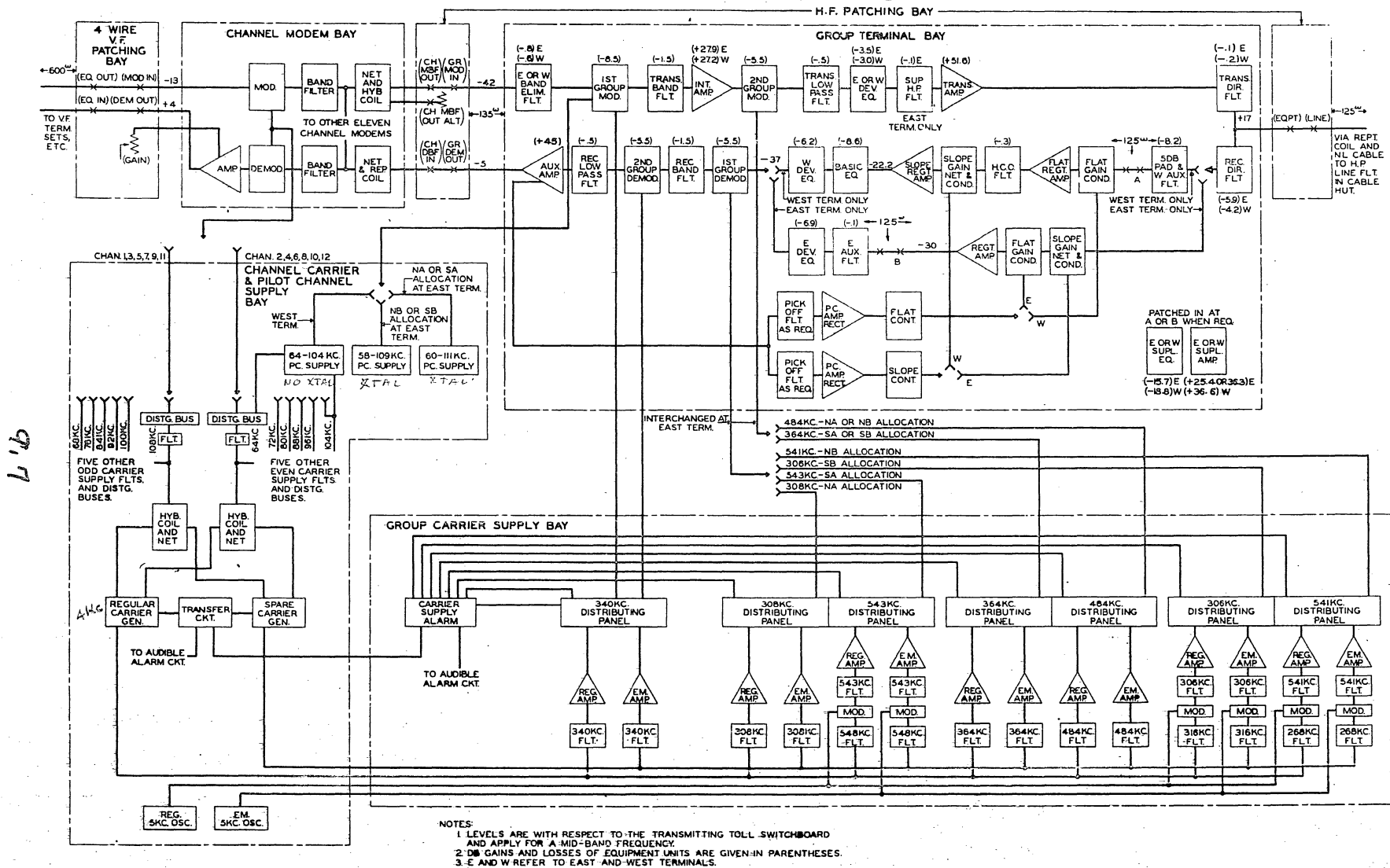

Figure 9-3 Over-all Schematic of the Type J2 Carrier Telephone Terminal

CHAPTER 9 TYPE "J" CARRIER TELEPHONE SYSTEM

Group Receiving Circuits

As shown on Figure 9-3, the received line frequencies are separated from the transmitted frequencies by a directional filter. At an east terminal, the received signals are applied to a regulating amplifier whose input circuit contains a slope-regulating network and a flat-gain regulating network. At a west terminal, which receives the high-frequency group of signals, more gain is required. There are therefore two amplifiers, one following each of the regulating networks. In both cases, the regulating networks are controlled automatically by the received line pilots. This control is similar to that employed in the line repeaters to be described later, except that in the terminals the pilots are picked off after passing through both group demodulators. The controls are effected by sensitive marginal relays, operated by the pilots, which actuate motors that adjust the regulating networks as required to maintain the level of the pilots substantially constant at the point where they are picked off.

The single amplifier used in an east terminal and the two amplifiers used in a west terminal, each are 2-stage amplifiers. Both east and west terminals include in their receiving amplifier portion of the circuits a deviation equalizer to compensate for the distortions introduced by the various filters in the receiving circuits and an auxiliary filter to supplement the receiving directional filter and further to attenuate the transmitting group of frequencies. In west terminals, the auxiliary filter is placed ahead of the amplifiers to prevent possible overloading by the unwanted frequencies. The west terminals also include a basic equalizer to help equalize the line, and a high cutoff (about 170 kc) low-pass filter to exclude unwanted high frequencies from the line, such as might be picked up from power line carrier systems, radio, or atmospheric static.

The features so far described, which are similar to features of line repeaters, will be more fully described in a later section.

After emerging from the receiving amplifier circuits, the signals are applied in succession to the two group demodulators. These are copper oxide structures similar to the modulators in the transmitting branch of the terminal. The first group demodulator is supplied with the appropriate one of the carriers listed in Figure 9-2 and translates the line frequencies to a band between 400 and 448 kilocycles. The second group demodulator is supplied with a 340-kc carrier and translates the frequencies to the basic group band between 60 and 108 kilocycles, suitable for application to the channel banks. Each modulator is followed by the necessary filter to select the wanted output band, and the final modulator is followed by an auxiliary 2-stage flat-gain amplifier having a fixed gain of 45 decibels to raise the signals to the standard level of -5 decibels required for the channel bank.

CHAPTER 9 TYPE "J" CARRIER TELEPHONE SYSTEM

Carrier and Pilot Supplies

The carrier and pilot supplies are shown functionally in the lower part of Figure 9-3. Many of the techniques employed in these circuits are similar to those described in the two chapters for the type "K" and type "L" systems and will therefore not be described in great detail here. All of the carrier frequencies which are multiples of 4 kilocycles are derived from harmonics of a basic 4-kc frequency, as in the type "K" system. The basic 4-kc frequency is obtained from a tuning-fork-controlled oscillator, and the harmonics of this frequency are generated by a saturated coil circuit. The output of the harmonic producer appears on two leads, the odd-harmonic bus and the even-harmonic bus. The particular harmonics needed for each carrier are picked from these busses by means of filters. In this way are obtained all of the carriers needed for the channel bank, the 340-kc carrier for the first group modulator, and the 308-, 364-, and 784-kc carriers when needed for the second group modulator.

For some of the type "J" system allocations, the second group modulators require carrier frequencies of 306, 541, or 543 kilocycles, which are not multiples of 4 kilocycles. To produce these, use is made of another base frequency, 5 kilocycles, which is generated by a tuning fork oscillator like the 4-kc oscillator. The 543-kc carrier is obtained by selecting the 137th harmonic of 4 kilocycles, namely 548 kilocycles, and modulating this against 5 kilocycles in a second-order modulator. The output component corresponding to the difference, $548 - 5$, is the desired 543-kc frequency. The 541-kc carrier is obtained by selecting the 67th harmonic of 4 kilocycles, or 268 kilocycles, and modulating this against 5 kilocycles in a third-order modulator. In a third-order modulator to which frequencies f_1 and f_2 are applied, output components of $2f_1 \pm f_2$ are obtained (see equations Chapter 5). In the present case, $f_1 = 268$ and $f_2 = 5$, and the desired output is $(2 \times 268) + 5 = 541$ kilocycles. Similarly, to obtain the 306-kc carrier, 316 kilocycles (the 79th harmonic of 4-kc) is modulated against 5 kilocycles in a third-order modulator, resulting in an output whose frequency is $316 - (2 \times 5)$ or 306 kilocycles. The modulator used in these circuits all employ copper oxide varistors, and are followed by filters to select the desired output component. Amplifiers are required in each circuit to obtain the needed carrier levels.

There remain the line pilots. At the point where these are introduced into the transmission circuits, at the input to the first group modulator, the required frequencies are 64 and 104 kilocycles in all west terminals, 60 and 111 kilocycles in east terminals of JNA or JSA systems, and 58 and 109 kilocycles in east terminals of JNB or JSB systems. These pilot frequencies are generated by individual vacuum tube oscillators. For the last mentioned pairs of frequencies required at east terminals, the oscillator frequencies are controlled by quartz crystals in the oscillating circuits. The frequencies 64 and 104 kilocycles required for the west terminals are identical with two of the channel carrier frequencies. For these cases, therefore, the crystals are omitted from the oscillators and the frequencies

CHAPTER 9 TYPE "J" CARRIER TELEPHONE SYSTEM

are accurately controlled by applying the 64- and 104-kc channel carriers to the grids of the oscillator tubes, locking the oscillators in step with those frequencies. The amplitudes of the pilots are adjusted so that their levels at the input to the line are each -3 dbm, where the transmission levels of the carrier channels are +17 decibels relative to the sending toll switchboard. The frequencies of the pilots when they reach the line are in every case, as noted earlier, 40 and 80 kilocycles out of west terminals and 92 and 143 kilocycles out of east terminals.

Most parts of the carrier and pilot supply circuits are provided in duplicate for greater reliability, with various alarm features and automatic transfer circuits which will not be described. One set of supply circuits is adequate for supplying ten J2 systems, provided not more than seven of them have the same frequency allocation.

9.3 REPEATERS

General

The type "J" repeaters must, of course, provide the gain, equalization, and regulation to compensate for the changeable line conditions which were described in the last section. The regulating features include automatic flat-gain and slope adjustments under control of two pilots in each direction of transmission. These are not different in basic principle from the flat-gain and slope regulation provided in the type "K" system as described in Chapter 10, but they must accommodate a wider range of conditions. Unlike the repeaters of the previously described carrier systems, the type "J" repeaters are different for the two directions of transmission because of the different frequency ranges and the consequent different line losses in the two directions.

The normal output level of each repeater is the same as that of the terminals, or +17 decibels. The output level of a repeater may be temporarily raised to +27 decibels without intolerable overloading, to take care of sections during severe sleet conditions. This is done by decreasing by 10 decibels the sensitivity of the pilot control circuits so that they automatically regulate to the higher level. All amplifiers are designed with negative feedback. This produces a high degree of stability, the gain being substantially independent of tube changes and battery voltage variations. For the same reason, the modulation is very low, the second- and third-order modulation products from a single-frequency testing tone of normal level being 75 and 95 decibels, respectively, below the fundamental. The maximum gains which can be obtained from the repeaters are 46 decibels in the west-to-east direction and 77 decibels in the east-to-west direction. The maximum gains that can be used under normal weather conditions are, of course, much less than these values, and are largely controlled by noise conditions.

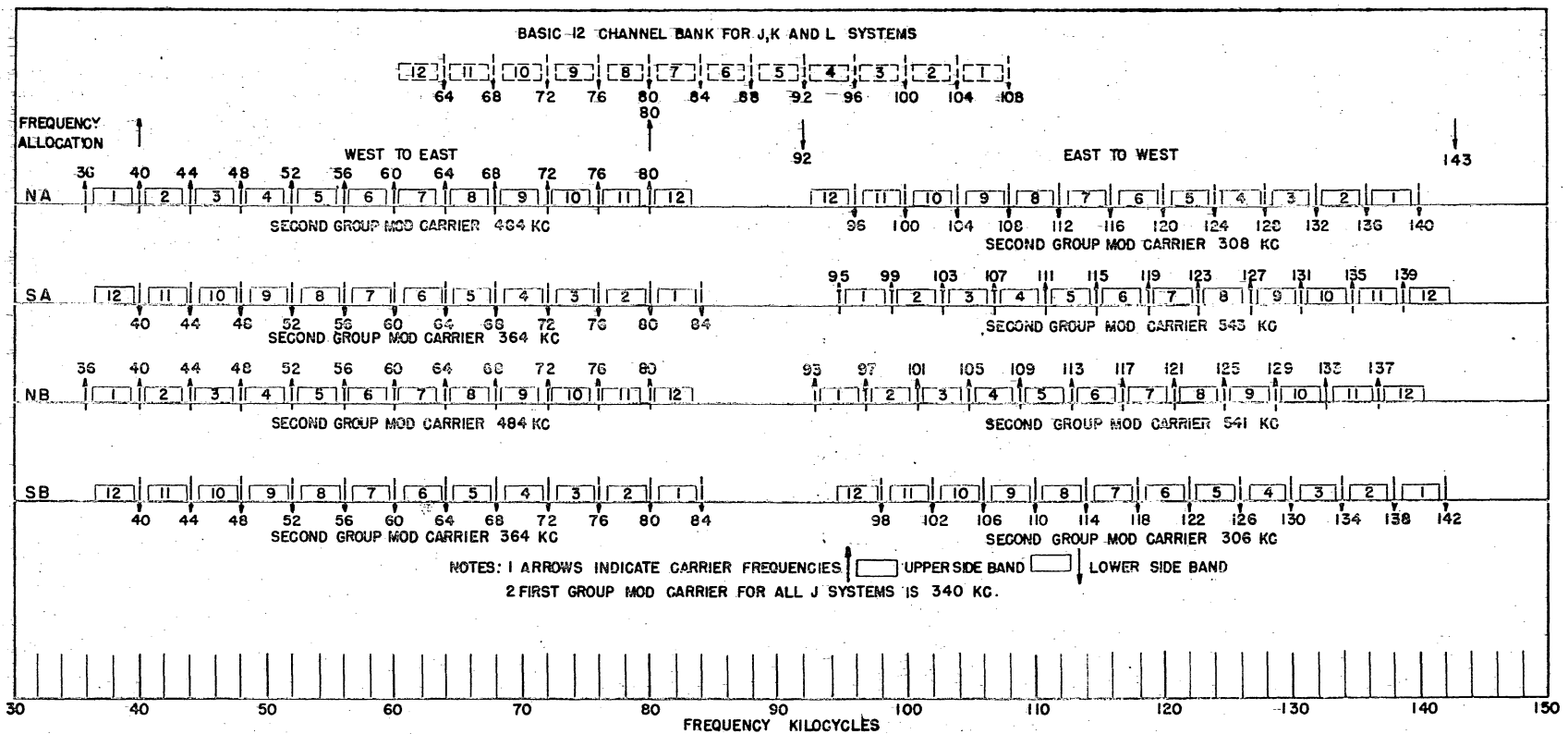

9.11

Figure 9-5 Frequency Allocations of Type J2 Carrier Telephone System

CHAPTER 9 TYPE "J" CARRIER TELEPHONE SYSTEM

The repeaters are divided into two classes, main and auxiliary. These are electrically and functionally similar. The main repeaters are in attended stations and are usually in the same locations as the repeaters of type "C" and voice-frequency systems on the same pole line. The auxiliary repeaters are unattended and are placed between the main repeaters. The number required depends upon whether the area is normally subject to sleet. With repeater spacings of 70 miles, fair performance can be expected for attenuations due to sleet which are as great as five times the dry weather values. In nonsleet areas, longer spacings may be employed. Each line must be engineered for the particular conditions expected in the area it traverses.

Repeater Spacings

The permissible spacing of repeaters is determined in the final analysis by noise, where the term "noise" includes line and repeater noise, crosstalk, and modulation.

In the type "J" case, the objective is a total noise of 29 dba on an average channel at a transmission level of -9 decibels, for a 4000-mile connection consisting of five links. It is computed in practice for the top channel whose frequency is taken to be 140 kilocycles, and the noise on this channel is allowed to be about 2 decibels worse than the average. Figure 9-6 shows the division of the total noise. For single links of shorter length, L, than 4000 miles, these quantities are reduced by $10 \log_{10} \frac{4000}{L}$, db.

	Noise at -9-db level (4000 miles)	
	<u>Average</u> <u>Channel</u>	<u>Top</u> <u>Channel</u>
Line and repeater noise	26 dba	27 dba
Unintelligible crosstalk	21	25
Modulation	22	22
Terminals	<u>20</u>	<u>20</u>
 Total (power addition)	 29 dba	 31 dba

Figure 9-6 Noise on Type "J" Systems

The largest item in the table of Figure 9-6 is the line and repeater noise. This noise on a particular section is expressed in terms of the noise at the input of the repeater that terminates the section. The contribution of the section to the total system noise is determined by increasing the noise at the repeater input by the difference between the standard -9-db level at the system terminal and the level at the repeater input. It is therefore evident

CHAPTER 9 TYPE "J" CARRIER TELEPHONE SYSTEM

that when sleet conditions in a section increase the line loss and depress the level at the repeater input, the contribution of that section to the total system noise is correspondingly increased. This indicates why repeater sections must be made shorter in sleet areas.

The equivalent repeater noise at the repeater input is only about -30 dba, and is too low to have an appreciable effect on the total noise. The line noise at the end of the wire section may be due to induction from power line carrier systems, to radio waves, or to static. The noise from power line carrier systems ordinarily occurs only in occasional sections where exposure exists, and must be considered on an individual basis. Static is a type of noise to which open-wire lines are universally exposed, and is a function of the thunderstorm incidence (TSI) which varies in different parts of the country. For a TSI of 1000 and a one per cent field strength (field strength exceeded one per cent of the time), the static noise at the input of a type "J" repeater (assuming lines with J5 transposition systems) is -4 dba at 80 kilocycles and -7 dba at 140 kilocycles. These figures allow 3 decibels for the fact that thunderstorms seldom occur simultaneously over all of a 4000-mile system. For other values of TSI than 1000, the noise figures may be corrected by adding $10 \log_{10} \frac{\text{TSI}}{1000}$, db. Data are available regarding the thunderstorm incidence in various parts of the country. The values given are yearly averages and actually vary during the year. Curves are available (see BSP AB25. 140) which show the distribution of the noise magnitudes around the one per cent values given above and the approximate number of hours they occur in the 5-month thunderstorm period from May through September.

The actual layout of repeaters in a particular system requires computing the system noise for different assumed repeater locations by methods involving the above considerations.

Repeater Circuits - Regulation

The general arrangement of a type J2 repeater is shown in Figure 9-7. The repeater is terminated at both ends in directional filters which separate from each other the high- and low-frequency bands used for the two directions of transmission. By comparing Figure 9-7 with the terminal circuits shown in Figure 9-3, it is seen that the repeater circuits up to the final line amplifier in each direction are much like the terminal receiving circuits up to the first group demodulator, the west-to-east repeater branch resembling the circuits at an east terminal, and the east-to-west repeater branch resembling the west terminal circuits. The line amplifiers of the repeaters are similar to the transmitting amplifiers of the terminals.

The west-to-east branch, which amplifies the low-frequency channels lying between 36 and 84 kilocycles, begins with a regulating amplifier which includes in its input circuits a slope-regulating network and a flat-gain regulator. The auxiliary filter which follows the regulating amplifier augments

CHAPTER 9 TYPE "J" CARRIER TELEPHONE SYSTEM

the directional filters and increases the loss at the higher frequencies amplified in the other branch of the repeater. It safeguards against overload and modulation difficulties in the amplifier and against having too little loss in the loop circuit around the two branches of the repeater when the gains are high. The auxiliary filter is followed by a deviation equalizer to remove residual irregularities from the over-all transmission characteristic, and by a line amplifier which is a flat-gain amplifier identical with the transmitting amplifier at the terminals.

The regulating amplifier is shown in somewhat more detail in Figure 9-8. The pilots which control the regulation are picked off by filters at the output of the line amplifier (see Figure 9-7), and after being amplified and rectified each is applied to a sensitive marginal relay. A change in the level of a pilot of ± 0.5 decibel causes the relay to close one or the other of two contacts. This operates a motor geared to the movable plate of the control capacitor shown in Figure 9-8 in such direction as to restore the pilot to its proper level. The relays are of the sensitrol type which give a firm, positive contact by the use of magnetic attraction between the movable contact which is of iron, and the fixed contacts which are magnets. All contacts are silver-plated. The magnetic contacts do not readily release, so automatic means are provided to reset the sensitrol relays about every 4 seconds, to stop the movement of the motors when sufficient correction has been obtained.

The slope-regulating network consists of a series of sections, and the movement of the capacitor plate effectively shifts the point along the network at which the output potential is derived. Although the network contains discrete sections, the regulation is continuous because of the design of the movable capacitor plate so as to overlap the sections of the fixed plate. A similar effect occurs in the flat-gain regulator, whose dual-stator capacitor can select any fraction of the impressed voltage.

The regulating arrangements for the west-east direction are designed to have sufficient range to compensate for the loss and characteristic with frequency of the line under all but extreme conditions. They, therefore, provide both the regulation and the basic equalization, and additional basic equalizers such as are used in the K and L carrier systems are not required. The flat-gain adjustments occurring automatically and simultaneously.

In the east-to-west branch of the repeater, more gain is required because of the greater loss of the line in the 92- to 143-kc range of frequencies used in that direction. The regulating portion of the circuit, therefore, includes two amplifiers, one following each of the regulating networks. The east-to-west regulating arrangements are shown in Figure 9-9. These are generally similar to the arrangements just described for the other repeater branch, except that the sections of the slope-regulating network are connected in parallel rather than in tandem. The flat-gain is controlled by the 92-kc pilot, and the slope by the 143-kc pilot in the same manner as for the west-east branch. Both pilots are picked off at the output of the line amplifier.

CHAPTER 9 TYPE "J" CARRIER TELEPHONE SYSTEM

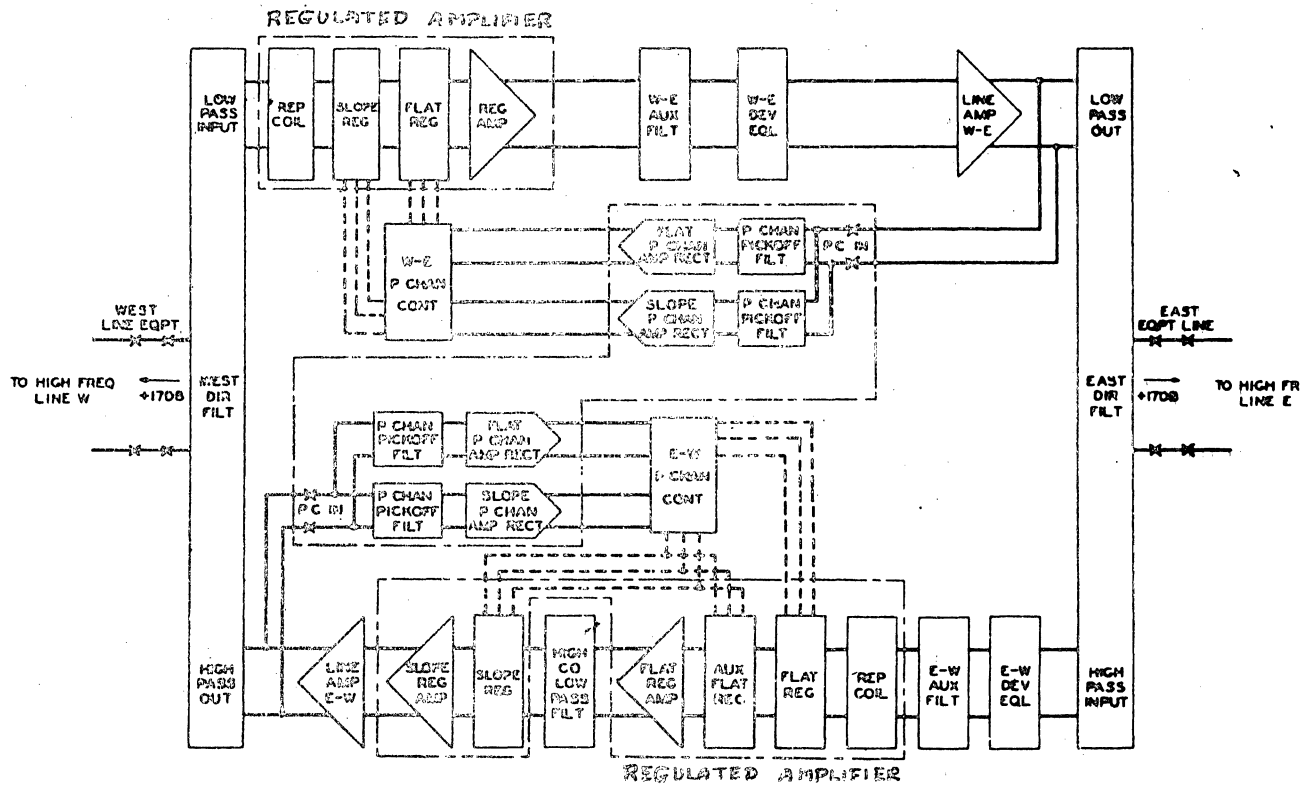
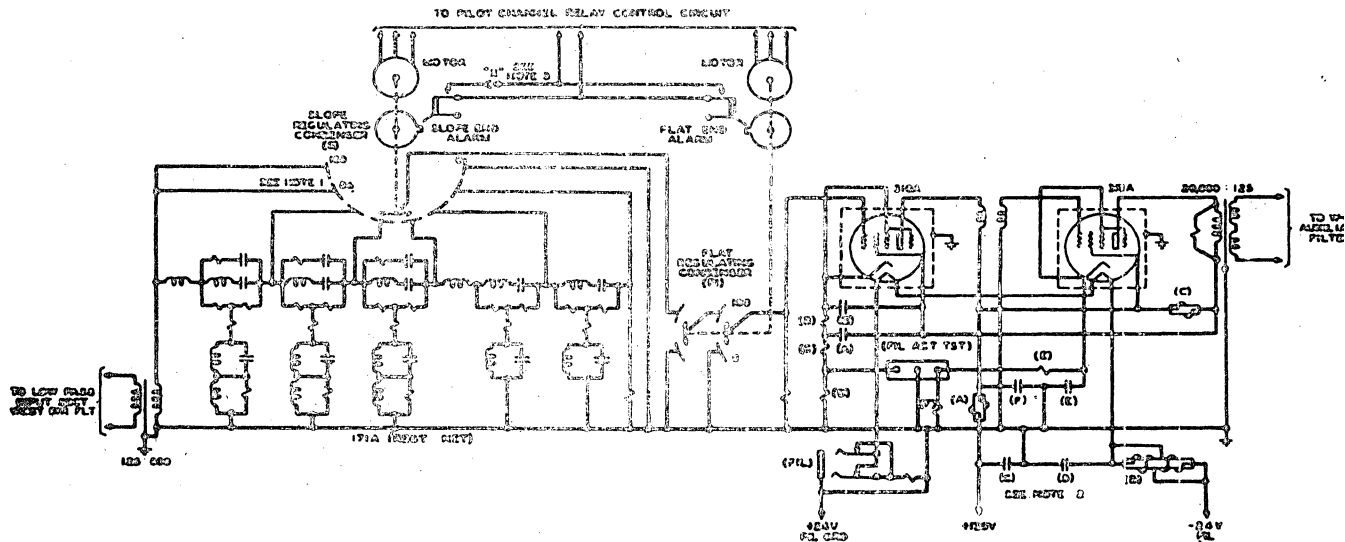

Figure 9-7 Block Schematic of the Type J2 Repeater



NOTE:

- 1 ON MODIFIED PANELS THE HIGH END STOP ON THE SLOPE DIAL, WITH WHICH THE HIGH END ALARM IS ASSOCIATED IS ROTATED TO BECOME EFFECTIVE AT A SCALE READING OF "66" INSTEAD OF "100".
- 2 BATTERY SUPPLY IS INDICATED FOR A MAIN REPEATER STATION.
- 3 "X" WIRING ON SLOPE DIAL NORMALLY PROVIDED MAY BE OMITTED WHEN LINE SECTION IS SHORT TO PREVENT FREQUENT HIGH END POSITION ALARMS.

Figure 9-8 West-East Regulating Amplifier Circuit

CHAPTER 9 TYPE "J" CARRIER TELEPHONE SYSTEM

A special feature is an auxiliary flat-gain control which is operated by the 143-kc slope pilot for a small region at one end of its range. This feature comes into action under extreme sleet conditions, when the slope regulator alone would have insufficient range to prevent abnormally high levels from being impressed on the line at the high-frequency end of the transmitted band. The auxiliary flat-gain control, of course, reacts on the regular flat-gain control because of its effect on the 92-kc pilot, sending the regular flat-gain adjustment to the end of its range. The net effect is a gain deficiency which varies from 5 decibels at 92 kilocycles to 0 decibel at 143 kilocycles. Since the extreme sleet conditions that could cause this are not generally very widespread, the gain deficiency is usually made up at the next repeater.

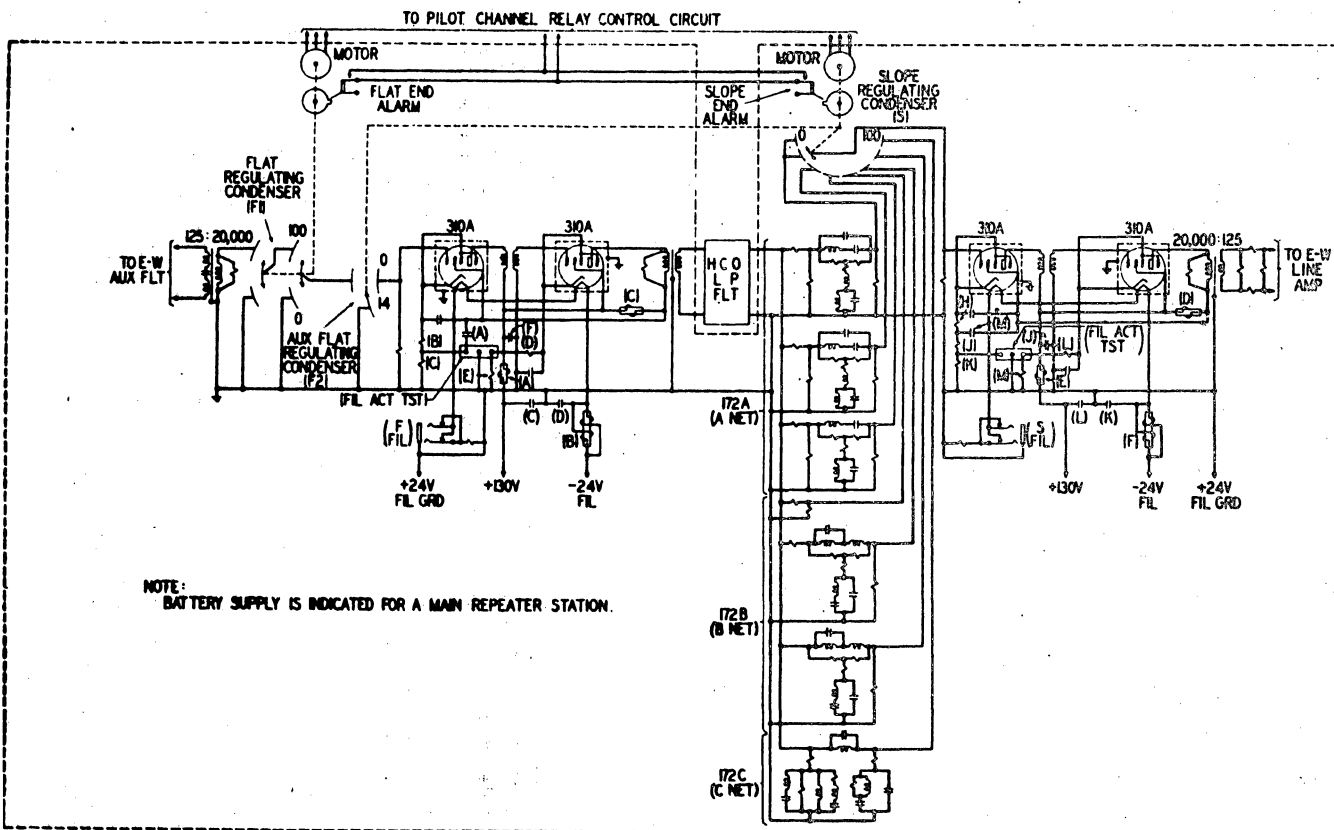

Figure 9-9 East-West Regulating Amplifier Circuit

The east-to-west regulating circuits are not quite adequate to take care of all the required basic equalization. The east-to-west line amplifier is therefore designed to provide part of the equalization. This is done by means of a network in the feed-back circuit.

CHAPTER 9 TYPE "J" CARRIER TELEPHONE SYSTEM

9.4 CROSSTALK PROVISIONS AT REPEATER STATIONS

The crosstalk between open-wire pairs is reduced to acceptable limits by transposing the wires and by staggering the frequency assignments of adjacent type "J" systems on the same pole line, as explained earlier. Additional precautions are required at the repeater stations, which will now be discussed. These are necessary largely because of the effect of the gain of the repeaters on the interaction crosstalk.

The principles as applied to type "J" auxiliary repeaters are illustrated in Figure 9-10. Usually not all of the pairs on a pole line are equipped with type "J" systems. The type "J" auxiliary repeaters are located at points where the non-J pairs have no voice-frequency or type "C" repeaters. The non-J pairs therefore provide "tertiary" paths which can conduct the interaction crosstalk from one side to the other of the type "J" repeater station. To illustrate this, Figure 9-10 shows three pairs, pairs 1 and 3 being equipped with auxiliary type "J" repeaters, and pair 2 having no repeater. Three possible crosstalk paths are shown.

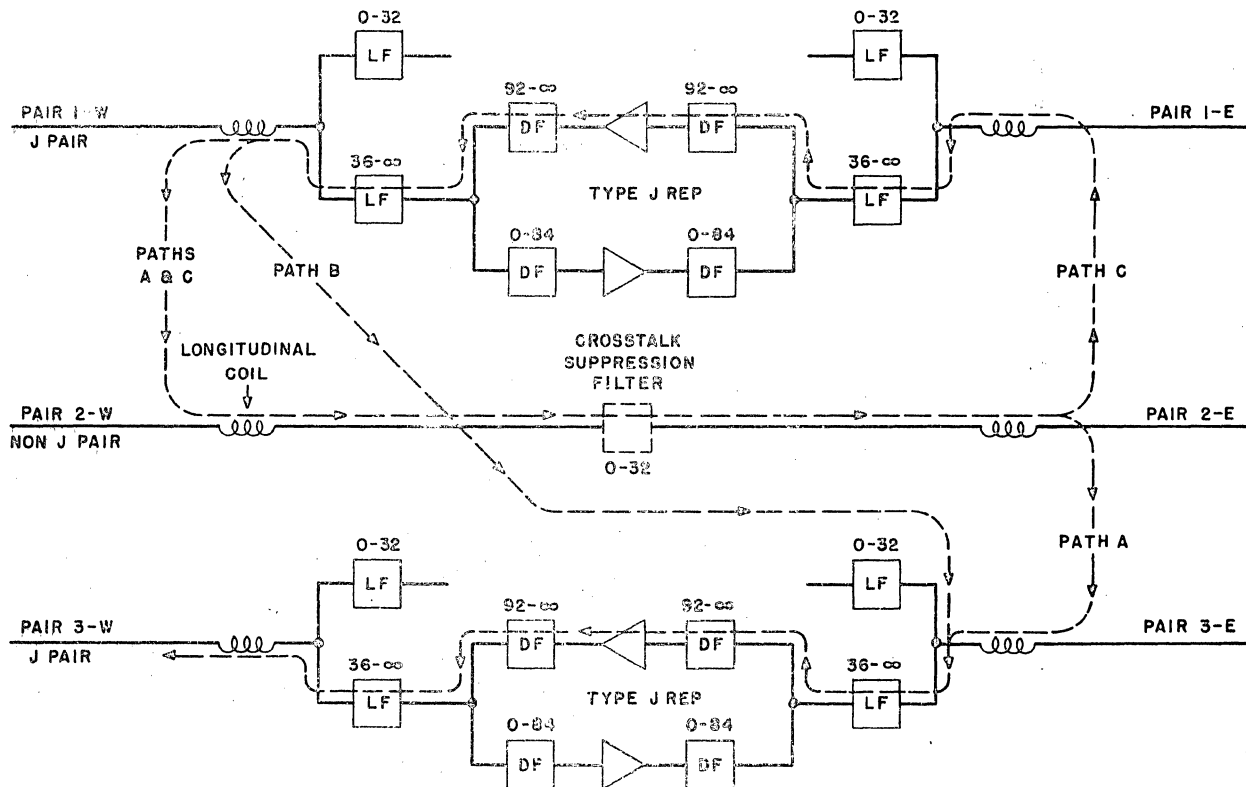

Figure 9-10 Coupling Paths Requiring Crosstalk-suppression Filters and Separation of East and West Cabling

CHAPTER 9 TYPE "J" CARRIER TELEPHONE SYSTEM

Consider crosstalk path A. Starting at the output of the east-to-west type "J" amplifier on pair 1 (transmission level +17 db), the carrier speech channels pass westward through the directional filter (pass band 92-kc to infinity) and the line filter (pass band 36-kc to infinity), where they join the type "C" and voice-frequency signals coming from the 0- to 32-kc line filter in the low-frequency branch. In the line proper, dissymmetries of pair 1 with respect to the other wires and ground cause the high-level metallic-circuit signals to induce longitudinal and metallic-circuit currents in all three pairs. The currents thus introduced in pair 2 are transmitted eastward past the repeaters, where they in turn induce currents in pair 3 at the low-level input to the east-west type "J" amplifier on pair 3. These crosstalk currents are then amplified and transmitted westward on pair 3.

Because of the gain of the repeater, this amplified interaction crosstalk could be serious if nothing were done about it. Two remedial measures are employed. One is the installation of longitudinal choke coils as shown in the figure, in all of the type "J" and non-J pairs of the line on both sides of the repeaters. It may be noted that for the part of the energy transfer paths just described that is between the numerous longitudinal circuits (a longitudinal circuit involves transmission along the two wires of a pair in parallel), wire configurations and transpositions are of no value. However, the longitudinal choke coils greatly increase the attenuation of the longitudinal paths and are therefore effective in reducing the crosstalk. The second remedial measure is the crosstalk suppression filter, which is connected in all of the non-J pairs which furnish the possible tertiary paths. This filter provides loss at the carrier frequencies for both the longitudinal and metallic-circuits of the pairs on which they are installed. By these two methods, the leaks around the repeaters are "plugged."

Crosstalk path C is similar to path A, except that the final coupling from the tertiary circuit is to the original instead of another system. This path could conceivably cause the repeater to sing. Obviously it is made innocuous by the same measures already described.

Crosstalk path B is different in nature from paths A and C, and involves straight coupling from the output of one repeater to the input of the other without involving any tertiary circuits. This path may arise from proximity between the east and west open-wire lines, or between the toll entrance or office cables. The attenuation of this path is kept sufficiently large by such measures as specifying that the terminal poles of the east and west open-wire lines be at least 80 feet apart, that the east and west lead-in cables be suitably separated, etc.

9.5 USE OF COMPANDORS TO IMPROVE NOISE AND CROSSTALK

The provisions which have been described for controlling noise and crosstalk on the open-wire type "J" systems are not wholly adequate to maintain the desired high transmission standards on all channels at all times.

CHAPTER 9 TYPE "J" CARRIER TELEPHONE SYSTEM

A further remedy, when needed, is available in the form of the 1A compandor. This device is applicable to any type of telephone circuit, but has found considerable use on type "J" system channels because of the greater transmission uncertainty of that system. Its cost makes it less attractive for use on other systems, but on type "J" systems is often less than the cost of obtaining sufficient improvement by other means. Less expensive compandors than the 1A have recently been designed as integral parts of the type "N" and the type "O" systems, but these are not available as separate devices for general use.

A compandor consists of a volume compressor applied at the sending end and a volume expander applied at the receiving end of a voice channel. These are complementary variable-gain devices controlled by the speech signals themselves. The compressor may be thought of as a device that adds gain for the weak, but not for the strong portions of the speech, thus raising the level of the weaker speech signals on the line and increasing their signal-to-noise ratio. The expander restores the speech at the receiving end to its normal level by adding loss equal to the gain introduced by the compressor. In so doing, the expander also attenuates the noise and crosstalk from the line when the speech signals are weak (or during pauses in the speech). Providing the noise and crosstalk are not initially so strong as to be heard through the loud portions of the speech, a large effective improvement in the signal-to-noise ratio is brought about by the compandor.

The cost of the compandor must of course be balanced against the cost of obtaining sufficient improvement by more elaborate line transposition schemes, closer spacing of repeaters, or other means.

CHAPTER 9 TYPE "J" CARRIER TELEPHONE SYSTEM

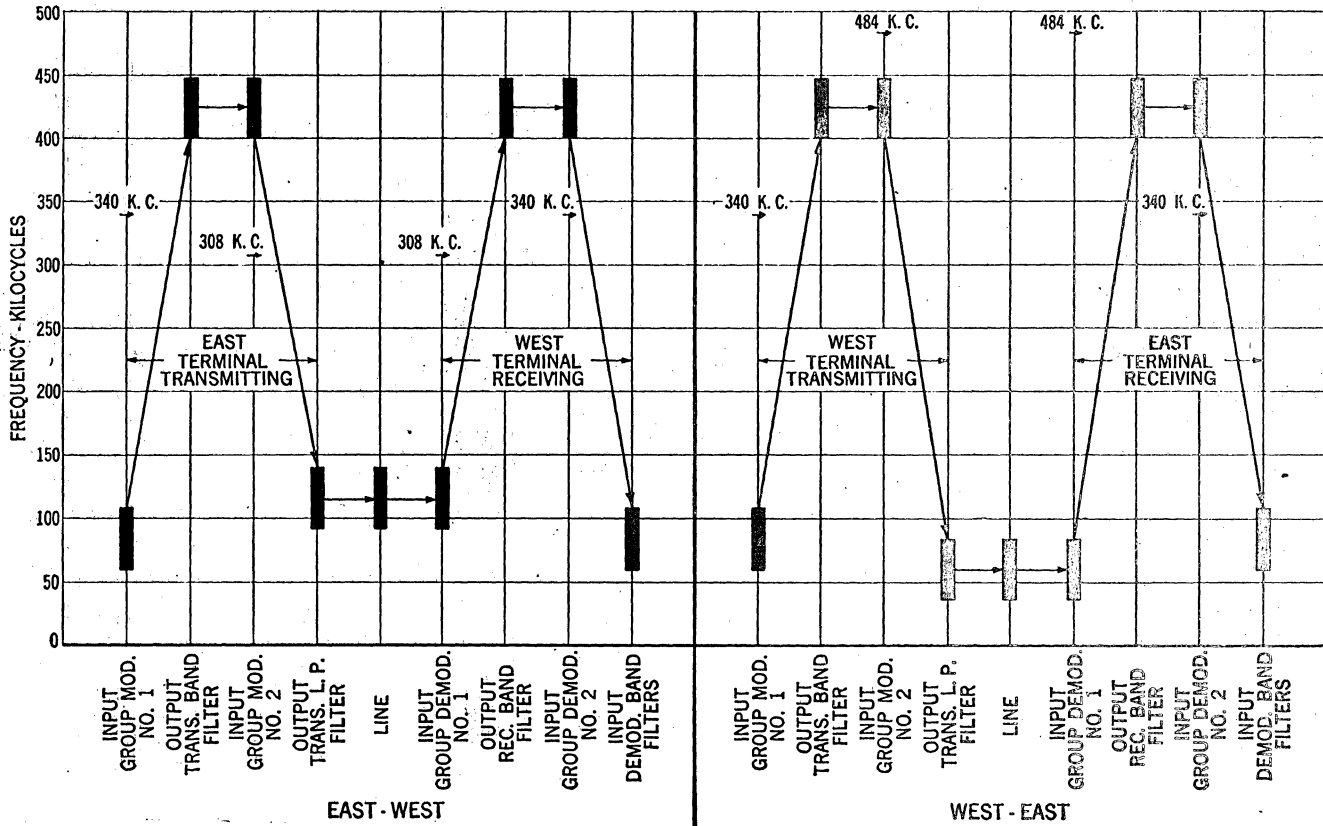

Figure 9-11 Frequency Translations in Type-J Carrier Systems

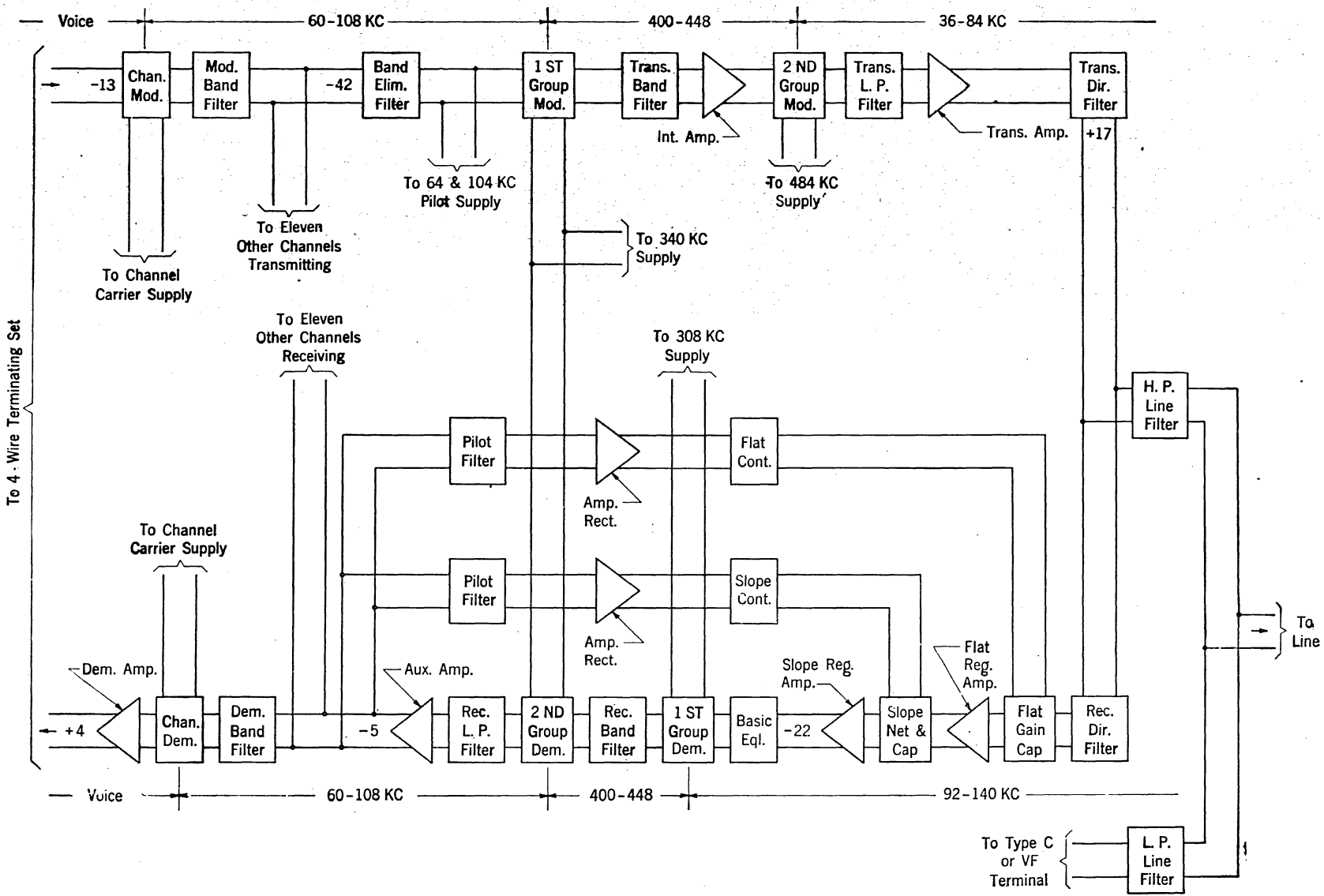

Figure 9-12 Type-J Carrier Telephone Terminal (West)

CHAPTER 10

TYPE "K" CARRIER TELEPHONE SYSTEM

10.1 GENERAL

The type K system provides twelve 2-way telephone channels on two 19-gauge nonloaded pairs in aerial or underground toll cables. These pairs cannot at the same time be used for voice-frequency systems. The type K system operates on a 4-wire basis using one pair for each direction of transmission. The two pairs are ordinarily in different cables, although in special cases a single cable may be used which has a shield between layers to separate the pairs into two groups. Because of the higher attenuation of the 19-gauge pairs at the carrier frequencies, the line amplifiers must be spaced at about one-third the interval required for voice-frequency systems, or about every 17 miles. On a route which also has voice-frequency systems, therefore, the carrier system requires two "auxiliary" repeaters between each pair of main stations where the voice-frequency repeaters are located. On new routes not already equipped with voice-frequency systems, the main, attended stations may be as far apart as 100 to 200 miles. The auxiliary stations are arranged to be unattended, with suitable alarm indications of troubles, to the nearest main station.

A number of type K systems may be operated in the same cables without exceeding crosstalk requirements, provided the cable pairs are suitably balanced for crosstalk as described in the last section of this chapter. On existing cables, installed originally for voice-frequency use, most of which are of the "long pair twist" variety, satisfactory performance may be obtained if as many as about one-third of the pairs are used for type K systems. On new type K routes, the usual arrangement is to install two small cables of the "short pair twist" variety, in which case all of the pairs except those needed for order wires and other miscellaneous purposes, may be used for type K systems.

Two models of the type K system have been developed: the original K1 system, and its successor the K2 system. The K1 system is no longer manufactured, although there are a considerable number in service in the plant. More than 85 per cent of the type K systems, however, are of the K2 variety, so the following description will apply specifically to the K2 system unless otherwise stated. The differences between the two models of the type K system, which have largely to do with the methods of regulation and equalization, will be mentioned at the appropriate points.

CHAPTER 10 TYPE "K" CARRIER TELEPHONE SYSTEM

The twelve telephone channels are transmitted on the cable pairs as the upper sidebands of carriers located every 4 kilocycles from 12 to 56 kilocycles, inclusive. The total frequency band transmitted on the line therefore extends approximately from 12 to 60 kilocycles. The original voice-frequency telephone bands are translated to the line frequencies, and vice versa, by a double modulation process. The first step takes place in the channel modulators forming part of a "12-channel bank," which translates the twelve voice bands to a group of lower sidebands, lying between 60 and 108 kilocycles. This is done in order to realize the economies obtainable with quartz filters, which type of filter would not be suitable at the lower frequencies that would be involved in a single modulation process translating the voice bands directly to the 12- to 60-kc range. The same 12-channel bank is also employed in the types J and L systems. The second stage of modulation in the type K system takes place in a group modulator which translates the 60- to 108-kc band as a whole, to the line frequencies between 12 and 60 kilocycles. The frequency allocations for the two stages of modulation are shown in Figure 10-1.

All carriers used in the modulation processes are suppressed, but pilot frequencies of 12, 28, 56 and 60 kilocycles (see Figure 10-1) are transmitted from the K2 terminals along with the carrier speech bands. These serve automatically to regulate the gain and the frequency characteristic of the system, the 60-kc pilot acting to regulate the flat gain of all of the line amplifiers, and the other three pilots serving to control the gain and the frequency characteristic of "twist" amplifiers placed in the line at occasional intervals. The methods by which this is accomplished will be described later.

No special signaling features are incorporated in the system, signaling being accomplished by voice-frequency methods over the telephone channels. Arrangements are available for removing telephone channels 6, 7, and 8 from a type K carrier system and replacing them with a continuous program channel of 8-kc bandwidth.

10.2 OVER-ALL TRANSMISSION PERFORMANCE

This section summarizes the over-all transmission performance which is expected of the type K system under normal conditions. The over-all transmission bandwidth of K2 channels, from toll switchboard to toll switchboard, is substantially flat from 200 to 3200 cycles, the loss increasing 10 decibels at about 150 and 3350 cycles. Five K2 channels in tandem are expected to provide a bandwidth of about 3175 cycles (175 to 3350) measured at the 10-db loss points. The transmission variations at 1000 cycles of a K2 carrier link of any length are expected to be less than +1 decibel, which, allowing for additional variations in the switchboards and other equipment in the terminal offices, might be increased to an over-all figure of +2 decibels.

CHAPTER 10 TYPE "K" CARRIER TELEPHONE SYSTEM

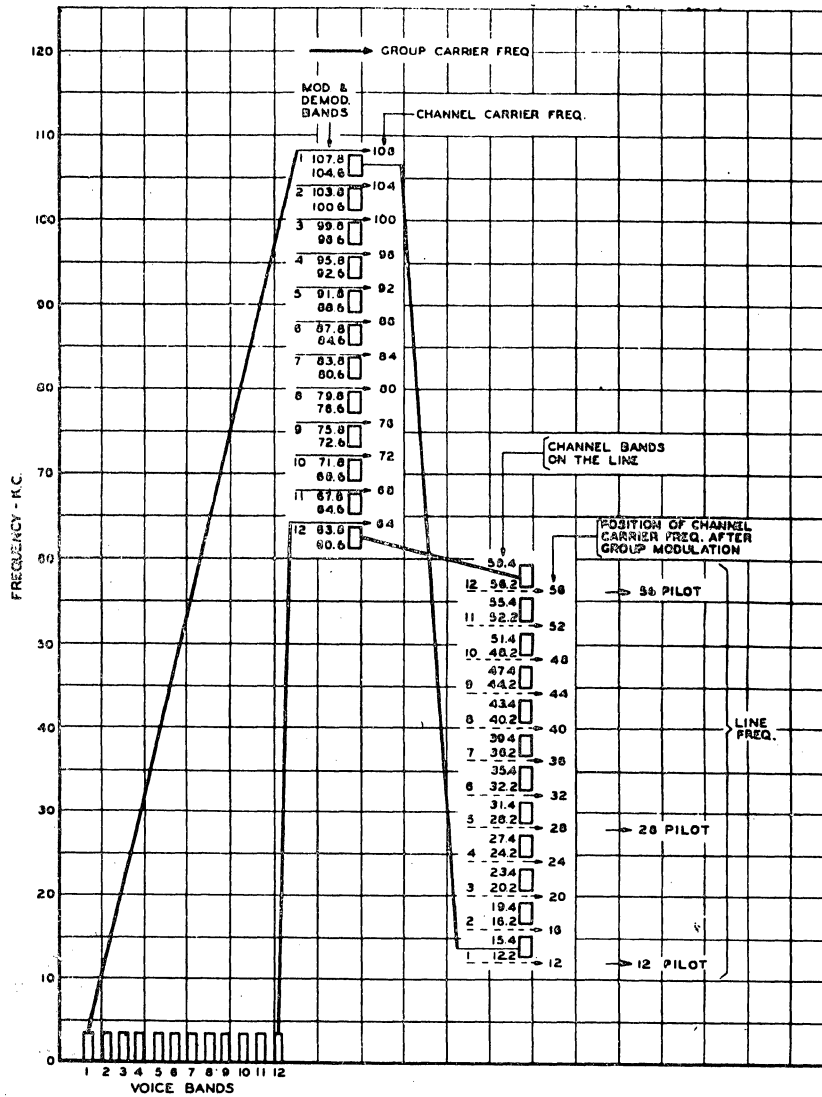

Figure 10-1 Frequency Allocations, Type K Carrier System.

The K2 carrier circuits have a line velocity, including the effect of the repeaters, of about 125,000 miles per second. The channel banks add enough delay to reduce the effective over-all velocity to about 105,000 miles per second.

CHAPTER 10 TYPE "K" CARRIER TELEPHONE SYSTEM

The K2 carrier circuits are designed to provide reasonably satisfactory crosstalk performance on a 4000-mile circuit composed of four 1000-mile links. This assumes a systematic connection of channels in the systems involved in the four links such that channels having the worst crosstalk in one link are in series with channels having better crosstalk in other links.

The noise on an average K2 channel 4000 miles long is not expected to exceed 29 dba at the -9 db level.

10.3 GROUP TERMINAL EQUIPMENT - FIGURE 10.17

General

The group terminal equipment, sometimes called the group modem, includes not only the group modulator and demodulator, but also the group filters, the transmitting amplifier, and all other equipment in the main transmission path of a type K carrier terminal between the 12-channel bank and the cable pairs except the receiving line amplifier. The principal functions of this equipment are, first, to perform the second stage of modulation required in the carrier terminal which translates the group of frequencies from the channel bank to the proper frequency allocation on the line and vice versa, and secondly to admix the pilot channel frequencies with the outgoing line signals at the proper levels. The 60-kc pilot is generated in the transmitting amplifier, but the other three pilots are generated separately in circuits to be described later. It is convenient to describe the group terminal equipment in two parts, namely the transmitting and receiving portions of the equipment.

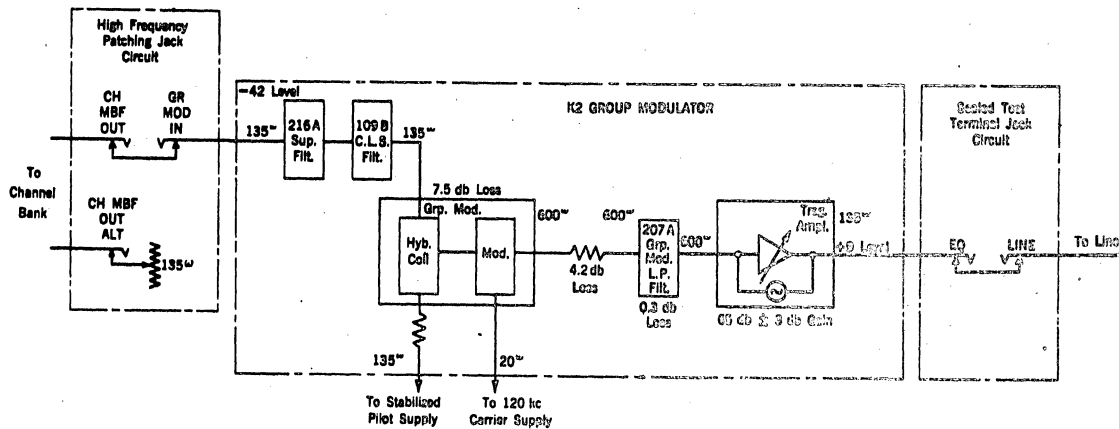

Figure 10-2 Group Modulator Circuit, Block Schematic

Group Modulator Circuit

A single-line block diagram of the transmitting branch of the group terminal equipment is shown in Figure 10-2. The heart of this equipment is the group modulator, which is shown separately in greater detail in Figure 10-3. The modulator is a lattice-type copper-oxide modulator.

The input transformer for the modulator is arranged so as to be a hybrid coil, the group of signal channels from the 12-channel bank being fed into the upper, and three of the pilot frequencies being fed into lower conjugate terminals of the hybrid coil circuit. The pilot frequencies at this point are 64, 92 and 108 kilocycles. These pilot frequencies are thus mixed with the 12-channel group and are modulated jointly against a carrier of 120 kilocycles, which is also applied to the modulator as shown in Figure 10-3. The lattice-type modulator is inherently balanced for both the input signals and the 120-kc carrier. The degree of balance is such that the input signals and the carrier are attenuated about 30 decibels.

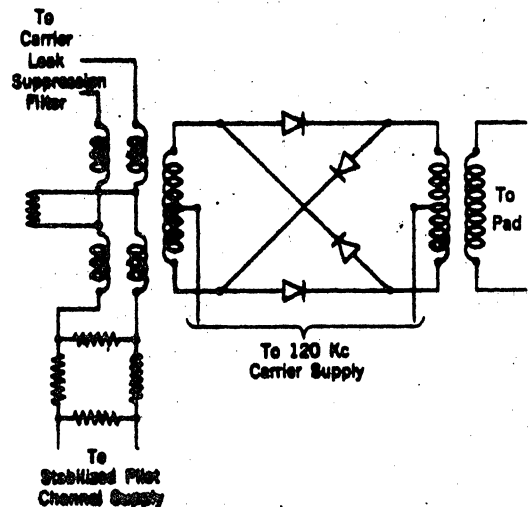

Figure 10-3 Group Modulator Schematic

The lower sideband of the modulation process is selected by the group-modulator low-pass filter (see Figure 10-2). This lower sideband consists of the group of twelve channels which now appear as upper sidebands of carriers (which are suppressed) of frequencies lying every 4 kilocycles from 12 to 56 kilocycles, and the three pilots which have been translated by the modulation process to frequencies of 56, 28 and 12 kilocycles. The level of these pilots is low compared with the speech levels in the carrier telephone channels, being -11 dbm at the output of the transmitting amplifier where the level of each speech channel is +9 decibels with respect to the toll switchboard level.

It is obvious that the pilot frequencies are identical with the carrier frequencies of channels 1, 5, and 12. It is necessary therefore to insure that the carrier leaks in these channels from the channel modulators are too weak to affect the pilot channel levels. This is taken care of by the two suppression filters shown in Figure 10-2 in the signal path ahead of the group modulator. The 109B carrier leak suppression filter adds an additional attenuation of about 40 decibels at frequencies of 64, 92, and 108 kilocycles. These suppression bands are extremely narrow, being only about +20 cycles wide, and therefore do not affect the bandwidths of the adjacent channels. The 216A suppression filter has the effect of widening the suppression band at 64 kilocycles to about +150 cycles. This

CHAPTER 10 TYPE "K" CARRIER TELEPHONE SYSTEM

is necessary to avoid interference from low-frequency signaling impulses which might enter channel 12 from the terminal, to the 56-kc pilot on the line. The regulating circuits in the twist amplifiers which operate on the 56 pilot are particularly sensitive to such interference.

The 4.2-db pad between the output of the modulator and the group filter is for the purpose of improving the impedance facing the filter. The group modulator filter is a coil- and condenser-type of filter designed to work between 600-ohm impedances. It is a low-pass filter which cuts off very sharply just above 60 kilocycles.

The transmitting amplifier is of a unique design which acts as an amplifier to the signal channels with about 65 decibels of gain, and at the same time behaves as an oscillator generating 60 kilocycles. The amplitude of the 60-kc pilot thus produced is a function of the energy in the signal channels, varying in such a way that the total mean power out of the amplifier, which is made up of the power in all the signal channels plus the power of the 60-kc pilot, remains constant at +15 dbm. When the channels are all idle, the power out of the amplifier is composed entirely of the 60-kc pilot. When the channels are busy, the strength of the 60-kc pilot is correspondingly decreased to maintain a constant output power of +15 dbm. The transmission level of each signal channel at the output of the amplifier is +9 decibels, relative to the toll switchboard.

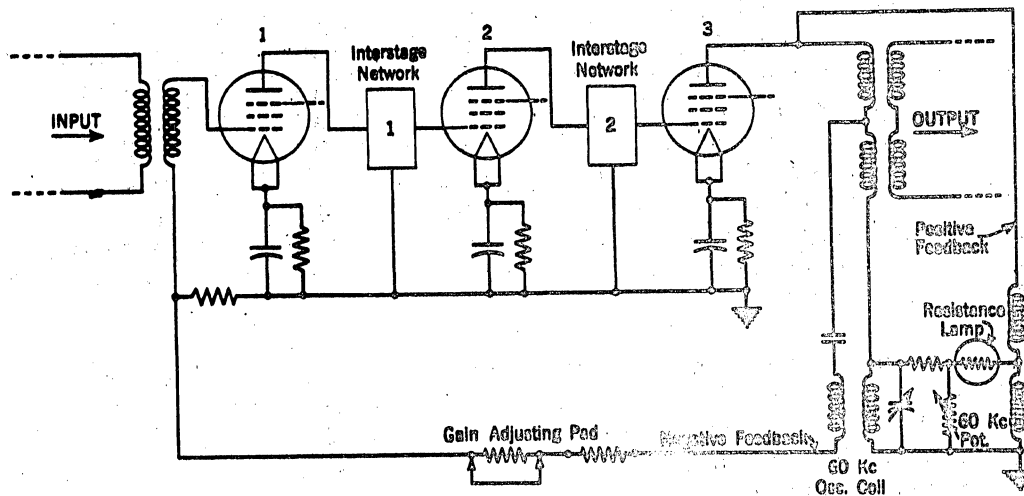

Figure 10-4 Schematic of Transmitting Amplifier

CHAPTER 10 TYPE "K" CARRIER TELEPHONE SYSTEM

A schematic of the transmitting amplifier is shown in Figure 10-4. It is a 3-stage amplifier having both a negative and a positive feedback path, the latter being sharply tuned to 60 kilocycles. The loss in the positive feedback path is controlled by the resistance of a resistance lamp, the resistance of the lamp and the loss in the feedback path increasing rapidly with the current through the lamp. The amplitude of the oscillations in such a circuit automatically stabilizes at the point where the loss in the feedback path is just short of being equal to the gain of the amplifier, so that oscillations are just sustained. The lamp is connected in the circuit in such a way that the signal currents from the amplifier as well as the 60-kc oscillations pass through it. Therefore the presence of energy in the signal channels increases the loss of the positive feedback path, requiring the 60-kc amplitude to compensate for this by decreasing until oscillations can again be sustained. The net effect is that the total power out of the amplifier remains constant. A potentiometer in the positive feedback circuit permits adjusting the level of the total power at which the amplifier stabilizes, and another one in the negative feedback path permits adjusting the signal gain. The output of the transmitting amplifier is sent directly into the outgoing cable pair.

Group Demodulator Circuit

A single-line block diagram of the receiving branch of the group terminal equipment is shown in Figure 10-5. The input of this circuit is connected directly to the output of the receiving line amplifier (not shown), where the transmission level of each channel is +9 decibels, and the nominal impedance is 135 ohms. The group demodulator is similar to the lattice-type modulator in the transmitting circuit just described, except that the input transformer is not a hybrid coil. Ahead of the demodulator are two large pads with a suppression filter between them for removing the 60-kc pilot frequency. The total loss in the two pads and the filter is 51 decibels, so that the signals applied to the demodulator are reduced to the low transmission level of -42 decibels, to avoid overloading the demodulator.

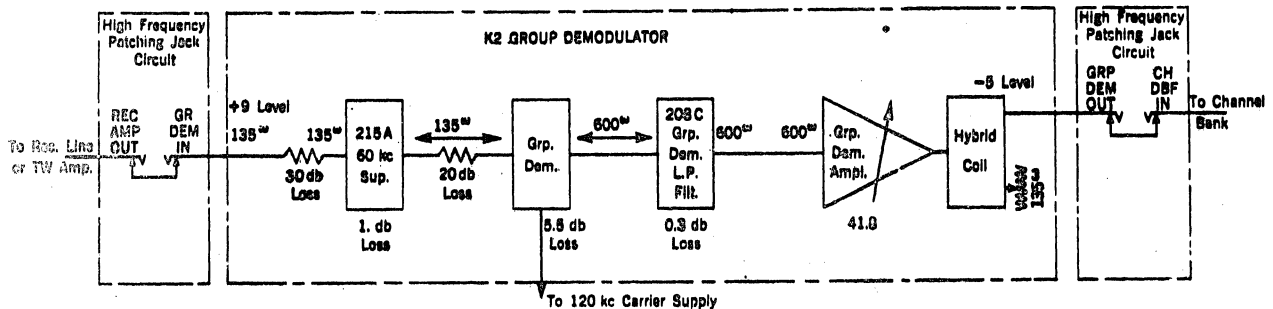

Figure 10-5 Group Demodulator Circuit, Block Schematic

CHAPTER 10 TYPE "K" CARRIER TELEPHONE SYSTEM

The group of channels from the line is modulated against a group carrier frequency of 120 kilocycles and the lower sideband produced by this process is selected by the group demodulator low-pass filter. Thus the group demodulator translates the 12- to 60-kc group of frequencies from the line to a group lying between 60 and 108 kilocycles, which is suitable for transmission to the 12-channel bank. The group demodulator filter is of the coil and condenser type, and cuts off sharply just above 108 kilocycles.

Following the filter is a group demodulator amplifier to raise the signal level to the -5 db level necessary for application to the channel bank. Two designs of amplifier are available, the second being required when the system is used for telephoto transmission. The other amplifier is not suitable for telephoto transmission because of slight modulation effects from the 60-cycle a-c power in the heaters of the tubes, to which telephoto transmission is particularly sensitive. Both amplifiers are flat gain amplifiers with a gain of about 42 decibels which is adjustable over a small range.

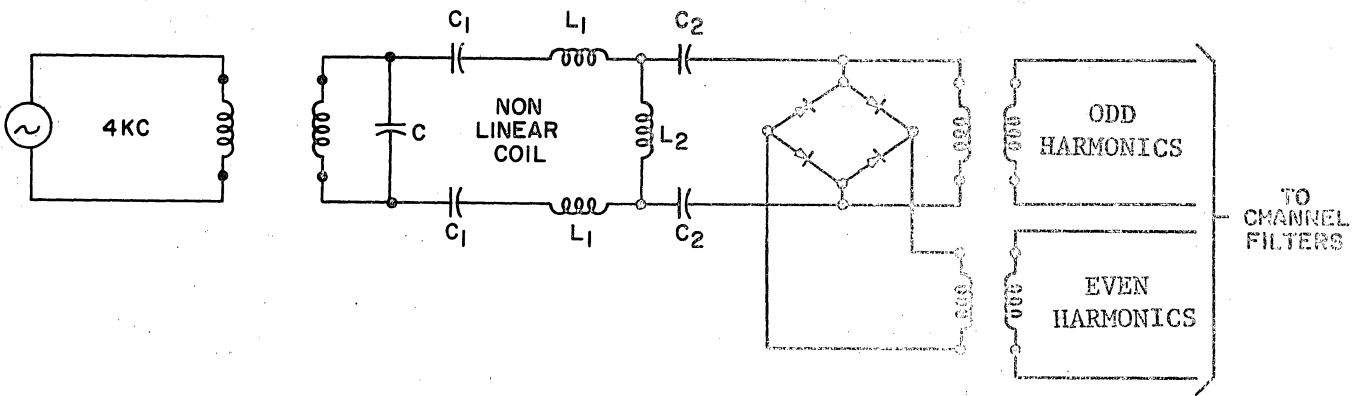

Figure 10-6 Carrier Supply Circuit

CHAPTER 10 TYPE "K" CARRIER TELEPHONE SYSTEM

10.4 CARRIER SUPPLY CIRCUITS

All of the essential parts of the K2 carrier terminals have now been described except the carrier and pilot supplies. It was noted in the preceding chapter that since the carriers are not transmitted, the frequencies of the carriers supplied to the terminals at the two ends of a system must be very accurate in order to avoid a frequency shift in the speech signals transmitted by the system. All of the carrier and pilot frequencies used in a type K system are multiples of 4 kilocycles. The principle which is employed therefore is to provide a stable generator of 4 kilocycles followed by harmonic producers which derive the required odd and even harmonics of the base frequency of 4 kilocycles. The accuracy of all of the frequencies is therefore determined by the accuracy of the one source of 4 kilocycles.

The fundamental principles of the arrangements in general use on type J and K systems are illustrated in Figure 10-6. The 4-kc base frequency is obtained from a 128-kc crystal oscillator through a fractional frequency generation process.

The 4-kc wave, after generation and amplification, first passes through tuned circuits which remove all harmonics generated in the oscillator or amplifier, and is then applied to the harmonic producer. This consists of the nonlinear coil, L_2 , and the capacitors C_2 . The coil has a small permalloy core and is heavily saturated by the applied current wave except when the current is near zero. The inductance of the coil is therefore very large when the current is passing through zero, and is very small during the rest of the cycle when the core is saturated, the change being very sudden from one condition to the other. The effect of this is that as the current in the coil passes through zero, say in the positive direction, a voltage is impressed on capacitors C_2 causing a current to flow into them and build up a charge on them. At a critical point the coil abruptly saturates and its impedance drops suddenly to a very low value. This practically short circuits the capacitors, so that they suddenly discharge, creating a large negative peak of current of short duration. When the current in the coil passes through zero in the opposite direction, a large positive current peak is similarly created. Thus the output of the harmonic producer consists of a train of sharp pulses of alternate polarity, one for each half cycle of the 4-kc wave.

This wave, being symmetrical, is rich in all the odd harmonics of 4 kilocycles and, by properly proportioning the circuit, the amplitudes of these harmonics are made uniform over a wide range. This wave appears directly on the odd-harmonic outlet or bus. Across this bus is bridged a group of filters that select from it the various odd harmonics of 4 kilocycles (68, 76, 84, 92, 100, and 108 kc) needed for the carrier and pilot supplies. The even harmonics are obtained by applying the above wave to a copper oxide rectifier, as shown in Figure 10-6, which inverts every alternate pulse. The wave from the rectifier contains all the even

CHAPTER 10 TYPE "K" CARRIER TELEPHONE SYSTEM

harmonics of 4 kilocycles and is led to the even-harmonic outlet or bus. Another group of filters bridged across this bus selects the various even-harmonics (64, 72, 80, 88, 96, 104, and 120 kc) which are needed for the remainder of the carrier and pilot supplies. It will be noted that since the output of the harmonic producer appears on two buses, one containing only the odd and the other only the even harmonics, the frequencies applied to either group of filters are separated by 8-kc intervals, which simplifies the selectivity requirements of the filters.

The 64-kc pilot is used to maintain carrier and pilot supplies in synchronism at all stations. A 64-kc pilot frequency derived from the carrier supply at the master station is transmitted over the network and is used to synchronize successive stations. At the master station, the 4-kc frequency supply circuit from which the 64-kc pilot is derived is set precisely to 4 kc by comparing it with an accurate frequency standard. At controlled stations, the 4-kc frequency supply circuit is motor-driven and continuously synchronized by the 64-kc pilot frequency received from an adjacent station in the network. Synchronization is accomplished in the frequency comparison circuit of the carrier supply. At the controlled station, this circuit compares the 64-kc pilot received from the network with the locally generated 64-kc pilot. When a difference exists between the two pilots, a motor driven by the frequency comparison circuit operates to eliminate the difference, so that the locally generated 64-kc pilot is at the same frequency as the incoming 64-kc pilot. The locally generated 64-kc pilot is then transmitted over the network for synchronization of the carrier supply at the next station in a similar manner.

One carrier supply of the above type is adequate to take care of ten to fifteen type K carrier terminals. Since so many telephone channels depend upon one carrier supply, it is provided in duplicate with automatic switching arrangements for switching over to the emergency supply in the event of failure of the regular carrier supply. The details of these switching arrangements will not be described here.

10.6 GENERAL LINE TRANSMISSION PROBLEM - EQUALIZATION AND REGULATION

The preceding sections have described the transmission features of the carrier terminals. We have seen how the sending terminals modulate the signals from twelve voice-frequency telephone channels so as to deliver to the outgoing cable pair a group of single sideband carrier channels lying between 12 and 60 kilocycles, each carrier channel having a transmission level of +9 decibels relative to the toll switchboard. We have further seen how four pilot frequencies are generated and applied to the line along with the carrier telephone channels, the weak 12-, 28-, and 56-kc pilots each having a level of -11 dbm, and the strong 60-kc pilot having a variable level such that the sum of its power and the power in the carrier channels (plus the other pilots) is +15 dbm. We have also seen

CHAPTER 10 TYPE "K" CARRIER TELEPHONE SYSTEM

how the receiving terminal accepts signals from the incoming line, which are identical in level and frequency with those delivered to the line by the distant sending terminal, and demodulates them to reproduce the twelve voice-frequency telephone signals.

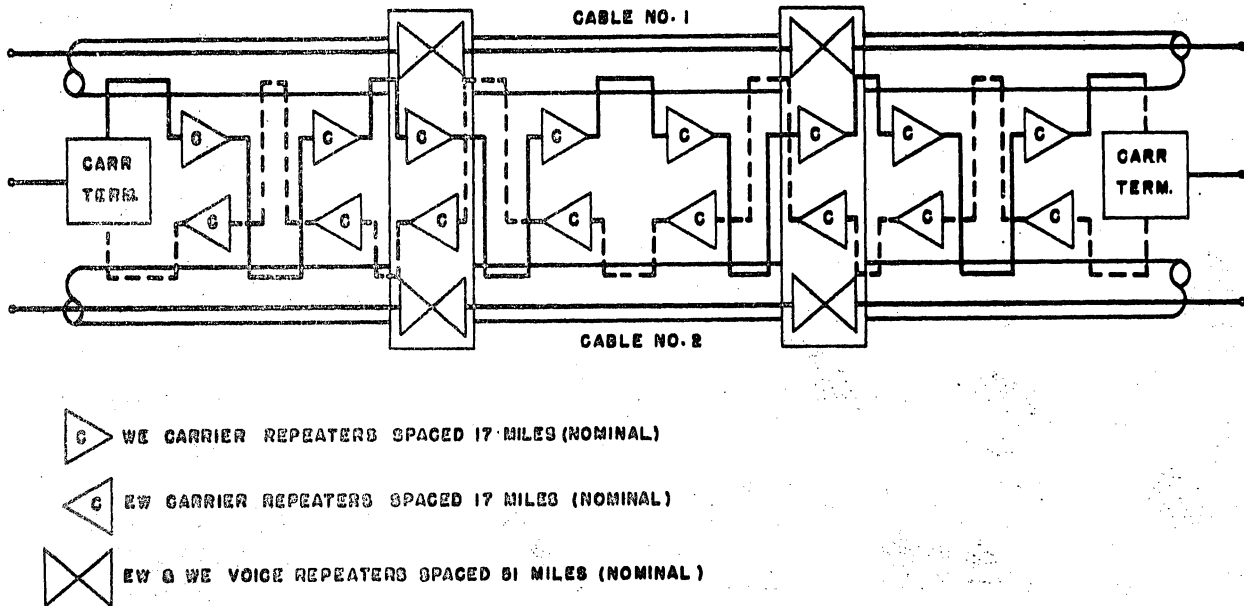

Figure 10-7 Cable Layout for Type K Carrier

The problem now to be discussed is how the line, with all its large and variable attenuation and attenuation-versus-frequency distortion and with its tendency to noise and crosstalk between cable pairs, is made to reproduce at the receiving terminal a good replica of the signals delivered to it by the sending terminal. The attenuation of the line is of course overcome by means of the amplifiers which are added to it at approximately 17-mile intervals. As noted earlier, the variations in transmission and the attenuation-versus-frequency distortion are also taken care of by equalizers incorporated in the amplifiers. Therefore, the discussion of this part of the problem reduces substantially to a description of the line and twist amplifiers, which follows in the next sections of this chapter.

The crosstalk phase of the problem is equally serious and important, for the crosstalk coupling between pairs in a cable increases with frequency and is therefore much worse in the carrier range than at voice frequencies.

Crosstalk is controlled for type K carrier operation by three measures, two of which are evident by inspection of Figure 10-7. This figure shows the manner in which the carrier system is applied to the cables. The first crosstalk reducing measure is the use of pairs in two different cables for

the two opposite directions of transmission. This effectively eliminates all near-end crosstalk between different type K systems using the same cables. The second crosstalk-reducing measure is the frogging of the oppositely directed one-way carrier channels between the two cables at each carrier repeater point. As shown in Figure 10-7 the two directions of transmission are alternated between the two cables in successive repeater sections. If the carrier circuits were not frogged, the high level signals at the output of a carrier repeater on one system could crosstalk into the paralleling voice-frequency pairs in the cable and could then be propagated back a short distance on the voice-frequency pairs to a point ahead of the carrier repeaters, where they could again crosstalk into another carrier system at the low level input to its carrier repeater. When the systems are frogged as shown, the second crosstalk coupling in the interaction crosstalk path just described terminates in the disturbed carrier system at a high level point at the output of a repeater, and therefore is less serious by the gain of a carrier repeater.

The above measures do not, of course, affect the transverse far-end crosstalk between carrier systems in the same cables. This is reduced by special carrier balancing of the cable pairs as described later.

Equalization and Regulation

The general principles of the equalization and regulation of long systems insofar as they apply to the type K carrier systems may be summarized as follows. The 19-gauge cable pairs of a 1000-mile type K carrier system in underground cable have a transmission loss at 60 kilocycles of 3780 decibels at mean temperature, a transmission loss at 12 kilocycles which is 1250 decibels less than this, and a variation of loss with temperature of +101 decibels at the maximum frequency. This is far from the whole story, however. In the first place, these are only nominal, presumably average, figures and particular circuits may differ from them either fortuitously due to manufacturing deviations, or systematically because the figures were derived from too few or nonrepresentative samples, and therefore are not really average figures. In the second place, the attenuation-versus-frequency characteristic as well as the attenuation at a fixed frequency is a function of temperature. In the third place, the amplifier, regulating networks and equalizers designed to compensate the line will be subject to statistical and systematic variations due to manufacturing deviations. In view of these uncertainties and deviations, it would seem at first glance quite hopeless to match the necessary large corrections against the above large losses, distortions, and variations, with sufficient accuracy to attain the refined over-all transmission performance specifications.

An analysis, however, shows that the transmission objectives can be satisfactorily met by proper application of basic equalization and of regulation, both of which are composed of the three components, described below, in suitable proportions. The basic equalization provides a fixed adjustment of the transmission characteristics which would be correct at mean tempera-

CHAPTER 10 TYPE "K" CARRIER TELEPHONE SYSTEM

ture for a reference cable pair (not necessarily a truly average cable pair) with the further implied assumption that the equalizers themselves do not deviate from the characteristics they are designed to have. The regulation compensates for the changes in the line characteristics resulting from varying temperature, and also for the deviations of the actual cable pair from the assumed reference cable pair and for the deviations of the equalizing networks from their intended characteristics. The regulation is of course automatic, under control of the pilot channels.

The three components of both the basic equalization and the regulation are as follows:

1. Flat Gain - This component, as its name indicates, is uniform at all frequencies.
2. Slope - This component represents a loss which, plotted in decibels versus frequency, is zero decibels at 60 kilocycles and increases along a straight line as the frequency is decreased to 12 kilocycles.
3. Bulge - This component has 0-db loss at both 12 and 60 kilocycles, but has a bulge between these frequencies which may be either positive or negative.

The term "twist" is applied to the combination of the last two components, slope and bulge.

The principle used in the type K systems, therefore, is both to equalize and to regulate the systems by applying the above three components in proper proportions by means of the amplifiers in the line and their associated circuits. This is accomplished in a slightly different manner in the K1 and K2 systems.

Method of Equalizing and Regulating K2 Systems

The amplifiers used in the line on the K2 systems are of two types, known as "line amplifiers" and "twist amplifiers". The twist amplifiers are installed every 100 to 200 miles, depending upon whether the cable is aerial or underground. The line amplifiers are installed approximately every 17 miles except at the points where twist amplifiers are located. The functions just described are incorporated in these amplifiers as follows.

All of the amplifiers, both line and twist, have incorporated in them the flat gain and slope components of basic equalization suitable for the particular length of line in the preceding line section. The flat gain is, of course, furnished by the mean gain of the amplifier. The slope is furnished by an equalizer connected in the input circuit of the amplifier. The bulge component of the basic equalization, being smaller in magnitude than the other two components, is furnished only at the twist amplifiers

where it is taken care of by the same network that supplies the bulge component of the regulation. The line amplifiers, in addition to taking care of the flat gain and slope of the basic equalization, also take care of the flat gain component of regulation necessary to compensate for variations in the loss of the preceding line section. They do this automatically by adjusting their gain under control of the 60-kc pilot as described in the next section. The twist amplifiers regulate the flat gain under control of the 56-kc pilot, the slope under control of the 12-kc pilot, and the bulge under control of the 28-kc pilot, as described in section 10.6. The above adjustments in both the line and twist amplifiers are made by thermistors located in the negative feedback circuits of the amplifiers.

The basic equalization provided by the arrangements just described is not quite perfect, partly because the amplifiers deviate somewhat from their design ideal and partly because the basic equalizers may be adjusted only in discrete steps. Therefore deviation or "mop-up" equalizers are provided in the input circuit of about every sixth amplifier. These make it possible to obtain a relatively flat over-all transmission frequency characteristic in each twist section.

Method of Equalizing and Regulating K1 Systems

The methods of equalizing and regulating the original K1 systems were based on the assumption that the loss characteristics of a 19-gauge cable pair can be specified with sufficient accuracy if its temperature is known. Basic equalizers were connected in the feedback circuits of each amplifier which compensated at mean temperature for both the slope and bulge of the particular line section connected ahead of the amplifier, assuming the cable pair was average. The variations with temperature were adjusted automatically under control of d-c pilot wires located in the same cable, whose resistance was a measure of the cable temperature. A pilot wire in each amplifier section thus controlled the flat gain of the amplifier as a function of the pilot wire resistance. Another pilot wire extending the length of a twist section (100 to 200 miles as in K2 systems) automatically controlled the slope and bulge corrections introduced by the twist amplifiers.

The method by which the pilot wires exercised these controls was somewhat similar to that employed in the pilot wire regulators of 4-wire voice-frequency systems. The master regulator connected to the pilot wire contained an automatically self-balancing Wheatstone bridge, which measured the resistance and therefore the temperature of the pilot wire. A Selsyn motor arrangement registered the setting of the bridge, and transmitted a control to motors associated with the amplifiers, which operated variable capacitors connected to networks in the feedback circuits of the amplifiers, to effect the desired changes in the characteristics. One master regulator could thus control the amplifiers of some fifty carrier systems operating in the cable.

CHAPTER 10 TYPE "K" CARRIER TELEPHONE SYSTEM

This method of regulation was found to be insufficiently accurate, because of differences in the characteristics of cable pairs, variations in the temperature between different cable pairs in the cable, and inaccuracies in the characteristics and settings of the control networks. There are still, however, some early K1 systems operating solely on pilot wire regulation. The errors from this kind of regulation are, of course, cumulative. To correct these errors, a third type of regulator called the "pilot channel deviation regulator" was provided. Originally, this was installed as a sort of mop-up regulator at intervals of about 500 miles. In some of the later K1 systems, however, the deviation regulator was substituted for the pilot-channel twist amplifiers, which were omitted.

The deviation regulator operates automatically on the 12-, 28-, and 56-kc pilots. These pilots were originally provided in the K1 systems only for purposes of measurement to check the performance of the system and to aid in adjusting the pilot channel regulators. No 60-kc pilot is used in K1 systems. Two amplifiers are installed at a deviation regulator point, the first of which is called a line amplifier, and the second a twist amplifier. The three pilot frequencies are picked off by filters at the output of the twist amplifier and, through control circuits, apply currents which are proportional to the pilot levels, to the heaters of thermistors whose change in resistance affects the controls. The 56-kc pilot thus controls a thermistor in the feedback circuit of the line amplifier and regulates its flat gain. The other two pilots control thermistors in networks located between the two amplifiers, the 12-kc pilot regulating a slope network and the 28-kc pilot regulating a bulge network. The regulation for all three pilots is such as to maintain the pilot levels substantially constant at the output of the twist amplifier. Both amplifiers have substantially flat gain characteristics.

The K1 regulating systems will not be further described in this chapter. Additional information concerning it can be obtained from references listed in the bibliography at the end of the chapter.

10.6 LINE AND TWIST AMPLIFIERS

This section describes in somewhat greater detail the line and twist amplifiers used in the K2 system. Since the regulation employed in these amplifiers is controlled by thermistors, it may be well first to describe these devices.

Thermistors

Thermistors (a contraction of "thermal resistors") are closely related to varistors; they may be described as thermal varistors whose conductance is varied by temperature. A thermistor is made of a semiconductor with a large temperature coefficient of resistivity. Its resistance can be varied over a wide range, the ratio of change being as great as a thousand

or more in some types. In the thermistors in use in carrier systems, the temperature coefficient is negative, the resistance decreasing with increased power input.

There are two general types of thermistors, the directly heated and the indirectly heated types. The directly heated thermistor is a disk or bead of semiconductor with two metallic terminals. A voltage applied across the two terminals causes current to flow through the semiconductor, and the resultant heating increases its conductivity. The directly heated thermistors may have a separate heater for controlling the mean ambient temperature in which they operate. In the indirectly heated thermistor, a separate heater controls the variations in temperature of the semiconductor. This form has four terminals. Both types of thermistor have a thermal lag, so that a definite time is required for the resistance to adjust itself to

a change in temperature. This time constant varies greatly for different types, ranging from a fraction of a second in some to many minutes in other types. The directly heated and certain of the indirectly heated types are mounted in vacuum to decrease heat losses and increase sensitivity.

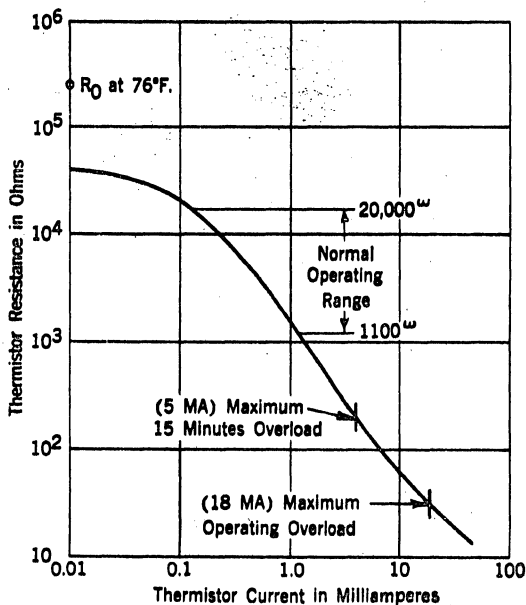

Figure 10-8 Thermistor D-161509 or 19A Used for Flat Gain Regulation in Line Amplifier, Directly Heated Type, Resistance Versus Thermistor Current 160F Ambient Temperature

Figure 10-8 shows the resistance-versus-thermistor current characteristic of the D-161509 or 19A directly heated thermistors which are used in the line amplifiers. The D-161509 thermistor has a time constant of about 18 seconds, and has been replaced by the 19A which has a time constant of about 90 seconds. The slower response of the 19A was found to be beneficial in reducing the transmission variations caused by ringing transients. These thermistors have an ambient temperature heater for maintaining a constant reference temperature of 160F. The current in the heater is made dependent on the air temperature by a special circuit containing another thermistor exposed to the air temperature.

The three thermistors used in the twist amplifiers as described later are of the indirectly heated type. The characteristics of the slope and bulge thermistors are shown in

CHAPTER 10 TYPE "K" CARRIER TELEPHONE SYSTEM

Figure 10-9, and the characteristic of the flat gain thermistor is shown in Figure 10-10. The time constants of the slope and bulge thermistors are very large - many minutes - while the time constant of the flat gain thermistor is very short - only a fraction of a second. Other thermistors, which will not be described, are used in the control circuits for these thermistors.

Line Amplifiers

A schematic diagram of the line amplifier is shown in Figure 10-11. It consists of a 3-stage amplifier, preceded by some pads and equalizers, and containing the directly heated thermistor described above in its feedback circuit. There are a number of optional circuits as follows:

1. The Equalizer and Pad Circuit at the input or output is used as required to build out the electrical length of short incoming or outgoing cables.
2. The Phase Equalizer is used to make the phase shift through the K2 line amplifier the same as through a K1 line amplifier. It is required on routes employing multisection crosstalk balancing, having both K1 and K2 line amplifiers.
3. The 4-db Pad is used to provide minimum gain.
4. The 2.5-mile Auxiliary Equalizer extends the range of the line equalizer, described below, to match a 20-mile section of line.
5. The Amplifier Deviation Equalizer or Auxiliary Amplifier Deviation Equalizer is used when needed to improve amplifier deviations.

The fixed elements which are always used are:

1. The Impedance Matching Circuit makes the input impedance of the amplifier match the line impedance.
2. Line Equalization provides the basic equalization for the line at mean temperature. It can be strapped so as to match accurately lines of 13, 15, and 17.5 miles in length. When the 17.5-mile strapping and the auxiliary equalizer referred to in (4) above are used, the total basic equalization fits a line of 20 miles in length, as noted above.
3. The Amplifier Proper introduces gain to make up the loss of the preceding line section. This will now be described.

The important feature of the line amplifier is the means whereby it regulates the flat gain. This is accomplished by the directly heated thermistor shown in series in the feedback path, between some shunt resistors. Through this thermistor flows a fixed fraction of the total output power of

CHAPTER 10 TYPE "K" CARRIER TELEPHONE SYSTEM

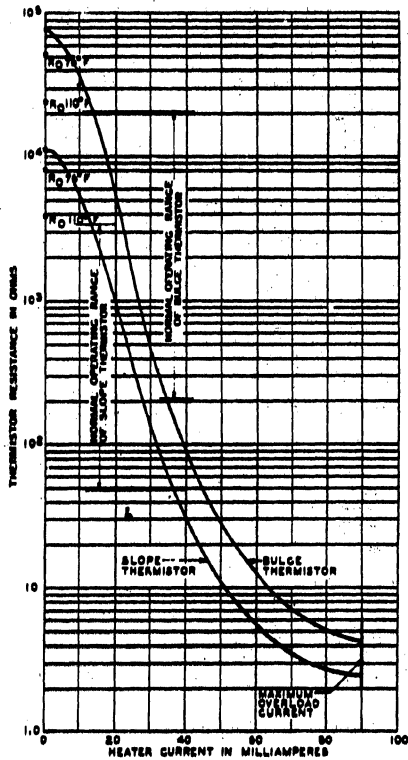

Figure 10-9 Slope and Bulge Thermistors - D160698 and D-160699, Indirectly Heated Type. Resistance Versus Heater Current 60F Ambient Temperature

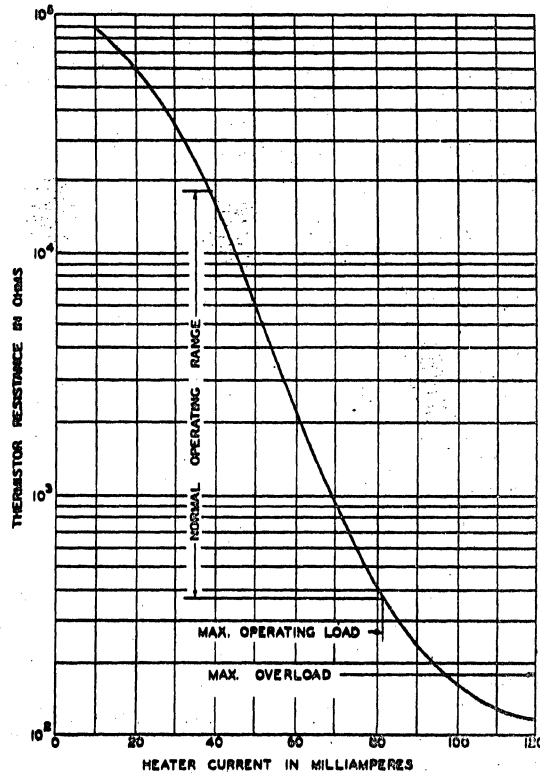

Figure 10-10 Flat Gain Thermistor in Twist Amplifier, Indirectly Heated Type. Resistance Versus Heater Current 60F Ambient Temperature

the amplifier which is made up of the sum of the powers in the 60-kc pilot, the twelve signal channels, and the three other pilots. If this power increases, say because of a change in temperature in the preceding line, the resistance of the thermistor decreases, which lowers the loss in the negative feedback path. This in turn decreases the gain of the amplifier tending to restore the output power to its previous level. The circuits are so proportioned that the output power tends to stabilize at +15 dbm, just as in the case of the transmitting amplifier described earlier. How well it does this is shown by the typical input-output characteristic curve of Figure 10-12. It is seen that the output level is substantially constant for a range of about 16 decibels in input level.

It will be noticed in Figure 10-11 that soldered taps are provided in the feedback circuit to change the gain in steps of 4 decibels. This permits adjusting the amplifier so as to be in the center of the regulating range shown by Figure 10-12, for mean conditions. A feature of pilot channel

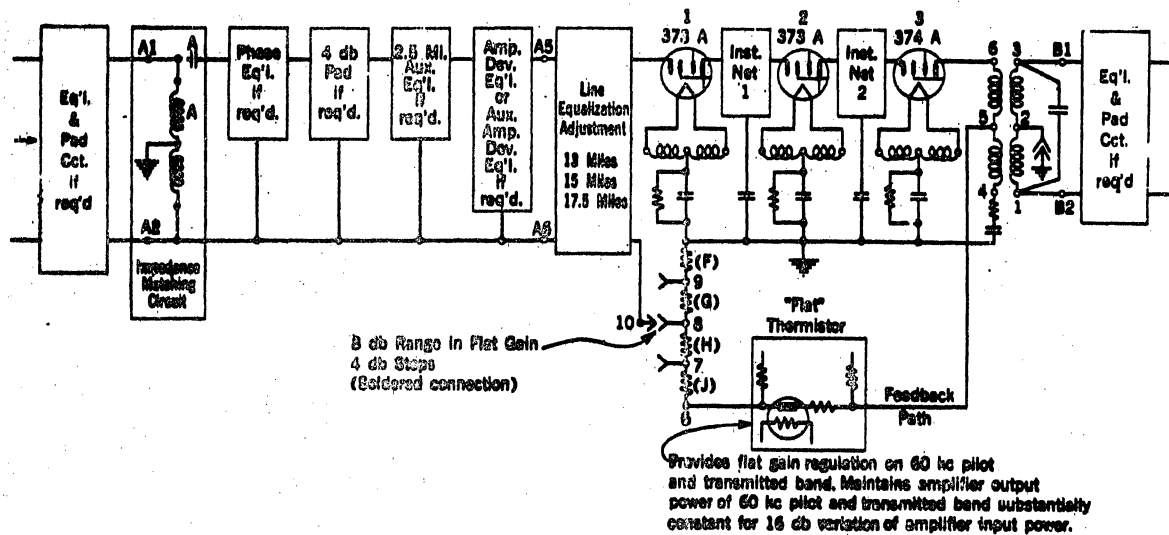

Figure 10-11 Line Amplifier, Regulating Type Schematic

types of regulation of the sort used in the line amplifiers, and also in the twist amplifiers, is that errors are not cumulative. The total errors in the system are those of the last regulating amplifier.

An important characteristic is the transient response of the amplifier to abrupt changes in level. This is shown by Figure 10-13, for one and for twelve line amplifiers in tandem. Transients of this sort are of course very undesirable in a long system. They are reduced to negligible proportions by making the flat gain regulation of the twist amplifiers fast enough to follow the slow transients and thus remove them, as described in the next subsection.

The gain of the line amplifier without feedback is 110 decibels and with feedback it varies, for mean conditions, from 45 to 72 decibels depending upon the strapping of the equalizers and the gain adjustments. There is therefore a large amount of feedback which greatly reduces the modulation in the amplifier. For example, with a single-frequency testing power output of +9 dbm at the output of the amplifier, the second - and third - order modulation products are about 80 and 85 decibels respectively, below the fundamental. The feedback also greatly improves the stability of the amplifier. The changes in gain due to tubes, power supply voltage, etc. are normally less than +0.1 decibel.

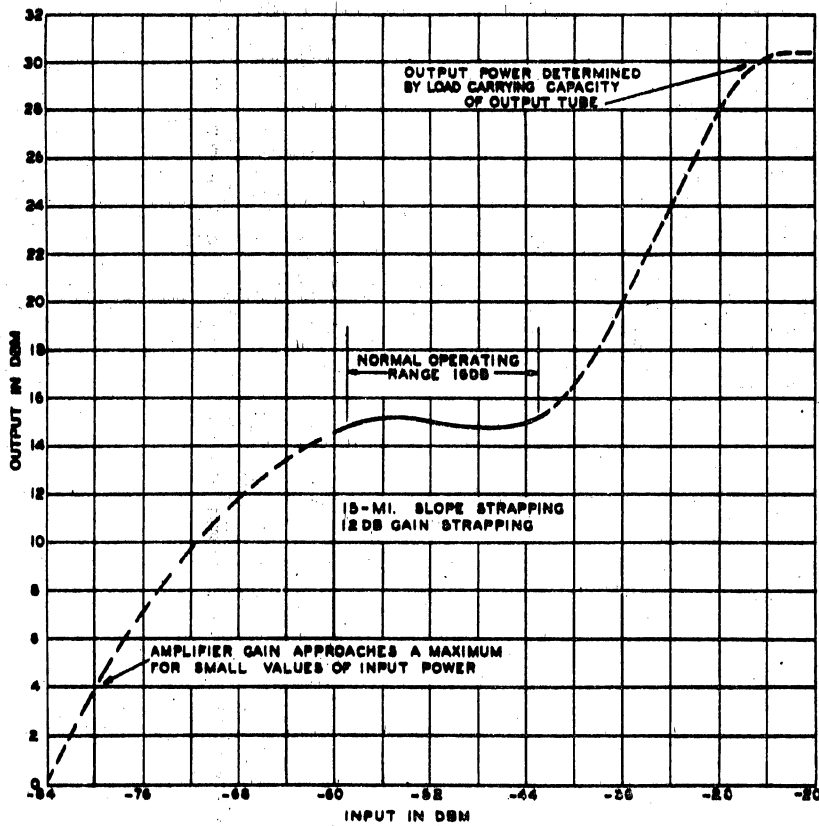

Figure 10-12 Line Amplifier, Typical Input-Output Characteristic at 60 kilocycles

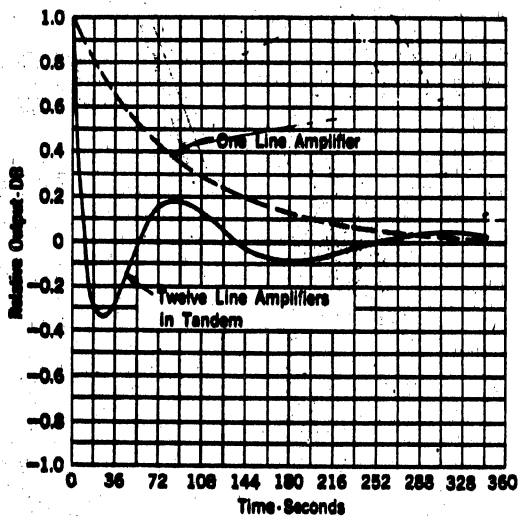

Figure 10-13 Line Amplifier - Time Required to Restore Output Power to Normal After Sudden Change in Input Power of 1 db. For One Line Amplifier and for 12 Line Amplifiers in Tandem - Thermistor 19A

CHAPTER 10 TYPE "K" CARRIER TELEPHONE SYSTEM

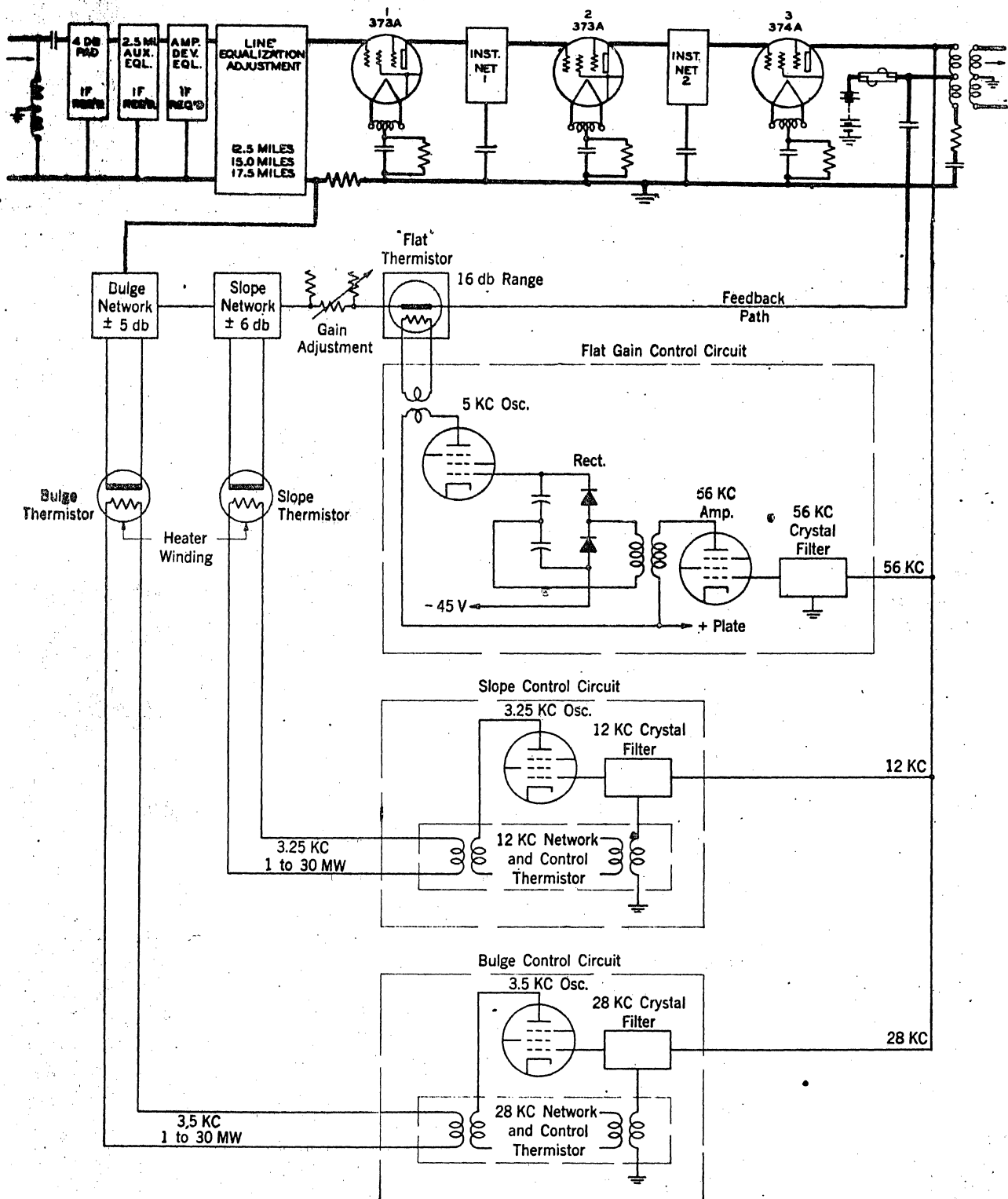

Figure 10-14 Twist Amplifier Schematic

The above describes the regulating line amplifier. In some cases on underground cables where the temperature variations are small, regulation is not employed at every line amplifier. The nonregulating line amplifier is identical with the regulating line amplifier except for the substitution of a fixed resistance network for the thermistor network in the feedback path of the amplifier.

Twist Amplifiers

A schematic of a twist amplifier is shown in Figure 10-14. The amplifier proper and the group of optional circuits and equalizers associated with its input and output are identical with those described for the line amplifier, except for the omission of the optional phase equalizer, and therefore the description need not be repeated here. The distinctive features of the twist amplifier are the three regulating circuits incorporated in the feedback circuit. These regulate the flat gain from the 56-kc pilot, the slope from the 12-kc pilot, and the bulge from the 28-kc pilot. The regulating circuits function to maintain a substantially constant level of these three pilots at the output of the amplifier. They do this by changing the resistance of indirectly heated thermistors associated with networks in the feedback path of the amplifier, the change being effected by means of currents from control circuits which are somewhat alike in nature for the three thermistors.

The three pilots are picked off by means of very narrow-band crystal filters across the output transformer of the amplifier. Each controls the amplitude of oscillations produced by an oscillator, the frequency of oscillation being 5 kilocycles for the flat gain control, 3.25 kilocycles for the slope control, and 3.5 kilocycles for the bulge control. This control is such that small changes in pilot level produce large changes in the amplitude of the oscillations. The oscillations are applied to the heaters of the respective thermistors.

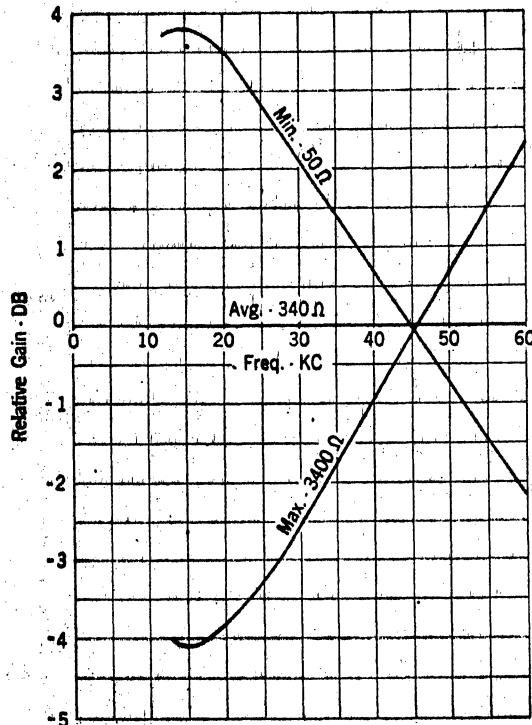

Fig. 10-15 Gain-Frequency Characteristics of Slope Network in twist amplifier.

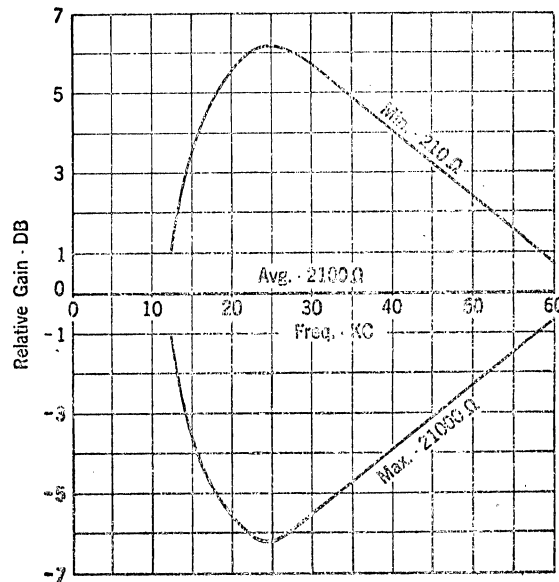

Fig. 10-16 Gain-Frequency Characteristics of Bulge Network in Twist Amplifier.

The flat gain thermistor which is controlled by the 56-kc pilot, is in series with the feedback path of the amplifier, and it controls the flat gain of the amplifier in a manner similar to that described for the line amplifier. The effect is to maintain the level of the 56-kc pilot substantially constant at -11 dbm at the output of the amplifier. It does this within about +0.4 decibel for a range of about 16 decibels in input level. As noted earlier, the flat gain regulator in the twist amplifier has a very rapid response, the time constant of the thermistor in it being only a fraction of a second. Adjustments of gain are provided in the feedback circuit to permit centering the regulation in the control range.

The slope and bulge thermistors are each connected to two terminals of a 4-terminal network whose other two terminals are in series with the feedback path. These networks are constructed of reactances and resistances and are so designed that variations in the resistance of the thermistors connected to one end of them affect the impedance introduced into the feedback path by the other end of the network in such a way as to produce the desired changes in characteristic. The effect of the slope network on the over-all characteristic of the amplifier is shown by Figure 10-15 and the effect of the bulge network is shown by Figure 10-16. The bulge characteristic is peaked at or near 28 kilocycles because it is at this frequency that the temperature coefficient of loss of a cable pair is greatest. The slope and bulge regulators function in such a way as to maintain the 12- and 28-kc pilots, respectively, each at a substantially constant level of -11 dbm at the amplifier output. These regulators have a very slow response, the time constants of the thermistors used in them being a matter of minutes.

10.7 CROSSTALK

This section discusses briefly the principles involved and the methods used in crosstalk balancing the cables for K carrier operation. As mentioned earlier, this treatment of the cable is necessary in order to reduce to acceptable limits the far-end crosstalk between type K systems operating in the same cables. To carry out the procedure requires measuring the crosstalk between every carrier cable pair and every other carrier cable pair, and then connecting crosstalk-balancing coils and capacitors between all the combinations of pairs as determined by the measurements, so as to reduce the crosstalk to a minimum. It can readily be seen that the amount of work and equipment required to balance a large complement of carrier pairs is great. Originally this balancing was done in every 17-mile repeater section. More recently it has been found possible to effect considerable savings by doing the balancing for three repeater sections at one point, because of the great uniformity of the carrier line amplifiers in their phase characteristics, as well as their gains.

Between channels of the same system crosstalk is negligible due to use of the negative feedback principle in all amplifiers of the K system. By proper design of the feedback path harmonic frequencies generated by the non-linear characteristics of the vacuum tubes may be suppressed over a very broad range of frequencies and the amplifiers of this type as used in K systems have been designed to be practically free of interchannel modulation effects. (Such effects may result, however, if one of the tubes goes bad.)

Between channels of different systems crosstalk may be either intelligible (from channels of the same frequency band) or in the form of babble (from channels of different frequency bands) resulting from inter-system reactive couplings and modulation effects. Such crosstalk is reduced to extremely low levels by the following means:

1. Uniformity of power levels for all systems operating in the same route sections.
2. Use of separate cables or shielded compartments in a single cable for oppositely bound transmission paths.
3. Separation and shielding between oppositely bound transmission paths in cabling at repeater and terminal station offices.
4. Use of inter-pair inductance balancing coils and capacitance balancing condensers at the receiving ends of each outside cable section, or at the receiving end of several sections in tandem.
5. Resplicing, poling and splitting of cable quads along existing routes.
6. Shielding between component parts of repeater and terminal equipment units.

CHAPTER 10 TYPE "K" CARRIER TELEPHONE SYSTEM

7. Use of common ground points in equipment elements.
8. Inter-action (secondary) crosstalk via paralleling V.F. office and outside cabling reduced to the very low values by use of longitudinal choke coils in V.F. cable pairs.

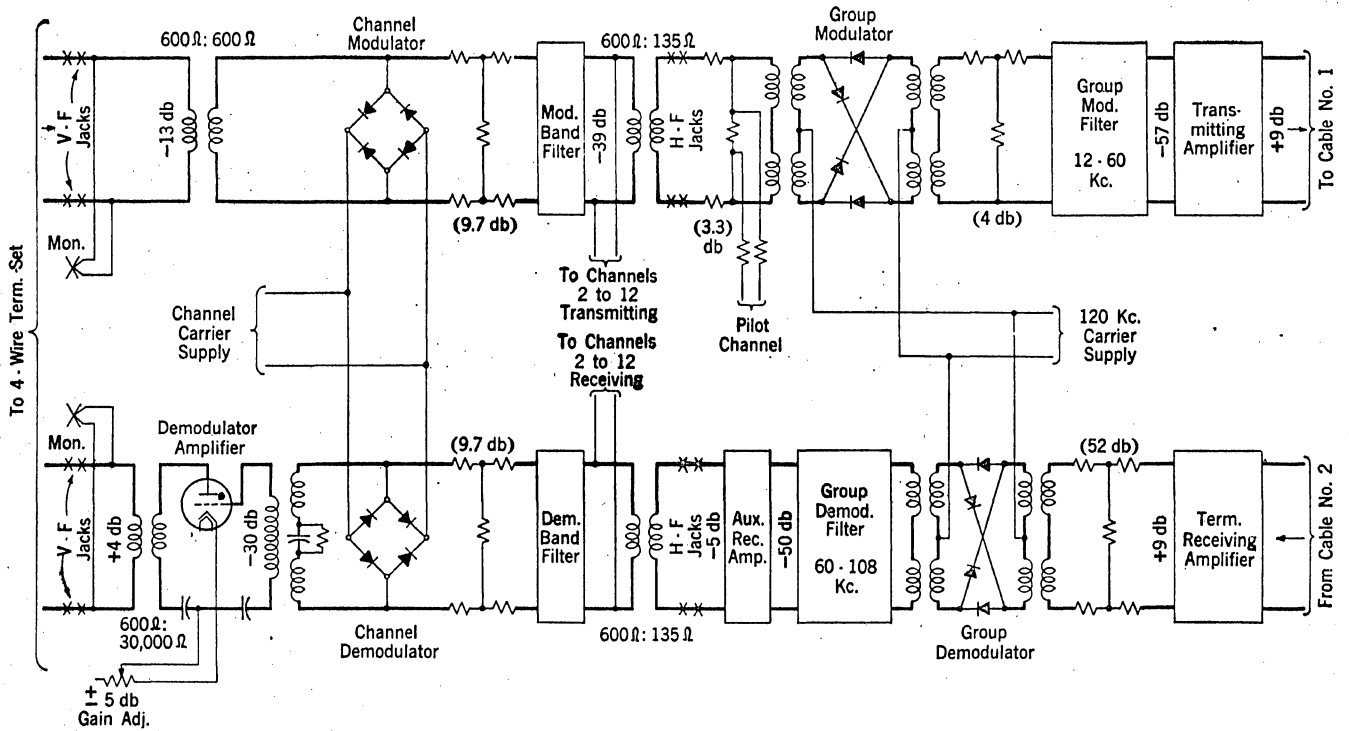

Figure 10-17 Type-K Carrier Telephone Terminal

CHAPTER 11

L CARRIER TERMINAL

11.1 MULTIPLEX FOR COAXIAL SYSTEMS

In the Type K cable and Type J open-wire systems for which the channel bank was first utilized, the translation to line frequencies was a simple matter because the system capacity was limited to a single group. For the much higher capacity L1 coaxial system both single-step and two-step modulation were considered.

A two-step plan was adopted for the following reasons:

1. Selectivity requirements on the band filters were eased.
2. Fewer types of band filters were required.
3. Fewer carrier frequencies had to be produced.
4. As in the case of the standard group output of the channel bank, a large group of channels could be provided in a second common standard frequency range. These two provisions insured that flexibility was built into the multiplex to facilitate interconnection of systems without requiring reduction to voice frequency for all channels.

Study of traffic conditions and the economics of various arrangements led to the conclusion that in the second modulation step the output of five channel banks should be combined into a basic supergroup of 60 channels. This basic supergroup from 312 to 552 kc also became standard both in the Bell System and internationally. In the original L1 multiplex eight supergroups were combined for line allocations from 68 to 2044 kc. Later two supergroups were added at higher frequencies, which were intended only for shorter haul traffic due to transmission limitations of the line.

The multiplexing arrangements which are represented by this array of groups and supergroups and the necessary carrier supplies encompass the equipment involved in the new L multiplex as shown in Fig. 11-1.

About a decade after the L1 coaxial cable system became a reality, a more complex multiplex was developed. This was required for the new L3 coaxial system which employed highly refined amplifiers and pilot regulators along with extremely accurate fixed and variable equalizers. With 4-mile repeater spacing instead of the eight miles of L1, the useful transmission band was extended to about 8 megacycles. A corresponding channel capacity of over 1800 channels was achieved. To attain this larger capacity a new concept of combining three mastergroups of 600 channels was introduced. The equipment developed for this final step of modulation has not yet been redesigned. However, the new L Multiplex does provide the necessary supergroups to form a basic mastergroup for the L3 terminals.

CHAPTER 11 L CARRIER TERMINAL

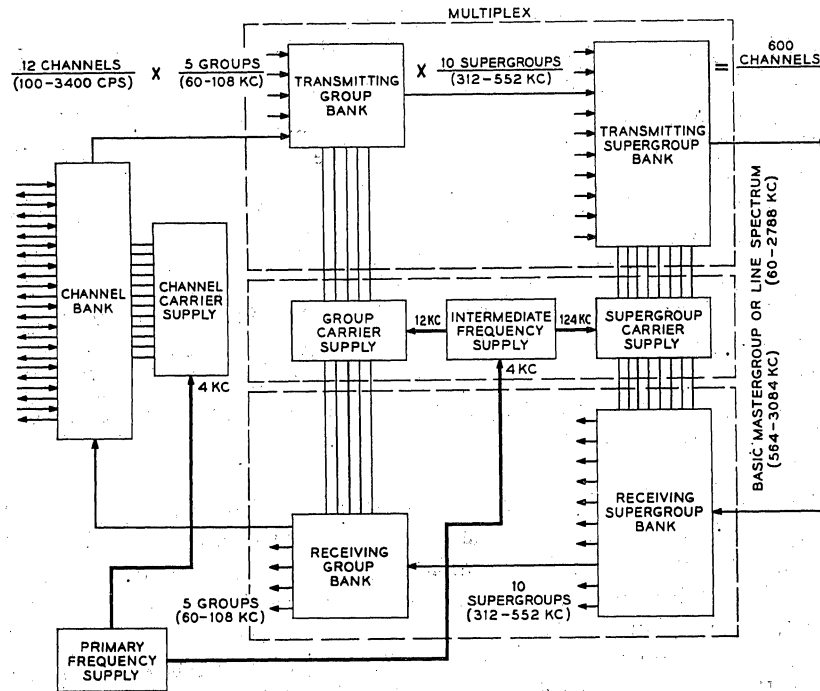

Fig. 11-1 - Broadband mastergroup; L multiplex equipment enclosed in dashed lines.

11.2 MULTIPLEX FOR MICROWAVE RADIO

The development of multiplex for wire systems antedated microwave radio systems by many years. However, with the design of the first commercial long-haul microwave radio system, TD-2, it was soon evident that the earlier multiplex developed for wire systems would be satisfactory for radio terminals. The 600 single-sideband, suppressed carrier channels of the L1 multiplex matched the load capacity of a TD-2 broadband channel for many applications. The use of the same multiplex for radio and wire systems offered significant benefits in standardization. For example, it permitted efficient and flexible interchange of traffic at offices using both types of facilities.

As microwave developments progressed, the standard terminal pattern was followed. The latest long-haul radio system, TH, employs the L3 mastergroup multiplex (1860 channels) on each broadband radio channel. The new short-haul lighter route radio systems, TJ and TL, use partial L1 multiplex arrangements up to their maximum load handling capabilities.

CHAPTER 11 L CARRIER TERMINAL

11.3 CARRIER SUPPLY

The decision to adopt uniformly spaced channels based on harmonics of 4 kc set the pattern for a common carrier supply. The earlier small-capacity systems for use on paired cables and open-wire lines used a primary generator based on a tuning fork to supply the 4 kc. Harmonics of 4 kc were formed by driving a saturable reactor as a pulse generator. The needed carriers and pilots were selected by filters. When the L1 multiplex was developed, many additional carriers and pilots were needed. Although the same general method was followed, certain alterations were made in the plan.

To obtain the higher absolute accuracy needed, the 4-kc base frequency was derived as a subharmonic from a high-stability crystal oscillator operating at the favorable crystal frequency of 128 kc. As before, the channel and group carriers were obtained from a 4-kc harmonic generator. For the supergroup carriers, however, a new 124-kc harmonic generator was added with this drive frequency derived from the 4 kc base. Frequency differences among terminals working together to provide certain special services such as VF telegraph and program were maintained to less than about one part in 10^7 . Frequency precision of this order limits the shift in all channels to less than 2 cps. This was accomplished by a system of master and slave 128-kc oscillators controlled by a standard reference frequency originating at New York.

11.4 STANDARD ARRANGEMENTS

A large-capacity multiplex is assembled from many repetitive units which may be considered building blocks. Each complete multiplex is an assemblage of such blocks uniquely suitable to terminate a particular broadband facility. With the introduction of a new multiplex family, it is desirable to use a readily understood descriptive designation for each complete multiplex. The new multiplex design is radically different, but the basic system plan has been retained and the multiplex applications are identical to those of the older equipment. In view of these latter factors and the field familiarity in referring to this equipment as the "L" carrier terminal, it was decided to retain "L" as part of the various general designations. In this usage the letter L implies single-sideband channels spaced at 4-kc intervals and assembled in the standard group, supergroup, and mastergroup format.

In the older L carrier terminal, designations such as "group bank," "supergroup bank," and "carrier supply" were used. These were functionally descriptive and were logical separations since assemblages of these functional units occupied many bays of equipment. With the very great size reduction achieved in the new multiplex, these lines of separation become blurred. For example, only one transmit and one receive bay are needed to provide the group, supergroup, and carrier supply equipment for a complete 600-channel terminal. These considerations led to the descriptive coding that has been applied to the standard L multiplex family.

CHAPTER 11 L CARRIER TERMINAL

The various codes are:

L600A - This is the multiplex to convert as many as 50 standard groups to line frequency allocations for L1 coaxial and TD-2, TJ, and TL radio. A maximum of 600 channels is available, but smaller numbers can be provided.

L1860A - This is the multiplex to convert as many as 155 standard groups into the basic mastergroups of the L3 coaxial and TH radio systems. A total of 1860 channels (3 mastergroups + 1 supergroup) are available but fewer supergroups can be furnished. These bays do not include the final step of modulation for translation from basic mastergroup to line frequency allocations.

L60A and L120A - These differ in principle from the equipments listed above in that they are complete packages providing channel banks and voice patching units as well as the group, supergroup, and carrier supply. A total of 60 or 120 channels is available but smaller numbers can be provided. These small packages are intended to provide economical terminals for light route TJ or TL radio systems or in other special instances where ultimate traffic needs are not expected to approach the capacity of an L600A.

11.5 PERFORMANCE OBJECTIVES

The ultimate objective for performance is that the new multiplex be suitable for the service demands of today and for those of the foreseeable future. One of today's more stringent demands has been brought about by customer Direct Distance Dialing. In manual operation, the end product of transmission service offered to the telephone subscriber had been inspected by the operator. In other words, a long distance telephone connection was offered to the subscriber only after the operators had conducted a satisfactory conversation over it. In Direct Distance Dialing, the subscriber himself is the first person who attempts conversation over the particular connection set up for his use by machine operation. The lack of inspection of the end product then requires much stricter maintenance of the individual facilities for adequate assurance that they will provide satisfactory service each time they are assembled in tandem to complete particular telephone connections. The number of subunits likely to be connected in tandem is increased by the complex plant layouts which make efficient use of the broadband facilities. A further increase occurs from automatic alternate routing during heavy traffic periods.

Transmission performance of the original multiplex has been generally satisfactory, and the broad objective for a new design is that its comparable performance be at least equally good. In view of the increasing emphasis on multilink operation, however, improvement in certain critical characteristics such as terminal noise and deviations from uniform frequency response across groups and supergroups would be desirable to the extent that it is economically feasible.

CHAPTER 11 L CARRIER TERMINAL

11.6 PHILOSOPHY OF DESIGN

The original multiplex design dates back more than twenty years, and it was quite obvious that substantial benefit could be realized from nothing more than redesign of equipment to exploit modern components and design techniques. That simple approach, however, would neglect the importance of maintenance and fail to recognize new requirements. The actual philosophy of design has been much broader with the main purpose of producing a family of multiplex arrangements to efficiently meet the needs of today and those of the foreseeable future. The following points have been emphasized:

1. Exploit advances in the art.
2. Retain features of proven integrity in the design now in use.
3. Correct known deficiencies of the design now in use.
4. Where design differences would threaten compatibility of new equipment with old, reasonable modification of equipment in plant should be undertaken in preference to accepting compromise in the new design.

An outstanding example of advance in the art is the use of new ferrite materials in components to effect dramatic reduction in the size of filters. This is especially significant since filters represent an important part of the total bulk and cost of a frequency-division multiplex.

Design features whose operational value has been proven by years of experience include the use of single-sideband channels with suppressed carrier, standard frequency allocations for basic groups and supergroups, and the use of pilots to monitor group and supergroup transmission. All of these worthwhile features should be retained in a new design.

The multiplex equipment now in use is known to be deficient in ease of maintenance to meet the strict demands of service today. The new multiplex should include terminal regulation and in-service maintenance access to minimize this deficiency. Another fault is that the older equipment was designed for heavy cross-section use and has not been economical where comparatively few channels are needed. A new multiplex design should include decentralized carrier supply to overcome this restriction in application.

In the original multiplex design, carrier power to drive the numerous modulators used in frequency translation was derived from a centralized block of interrelated equipments. Such a centralized carrier supply is economical when fully loaded because its cost is shared by a large number of telephone channels. However, this high cost of common equipment is a serious deterrent at small terminal applications. In a new design, it is practical to consider generating carrier power in small equipment units to be mounted close to the point of use. Such a decentralized carrier supply minimizes the cost of getting started and enables the addition of carrier supply capacity

CHAPTER 11 L CARRIER TERMINAL

in smaller increments as needed. A supplementary benefit of decentralization is to minimize the bulk of interbay cabling. This is possible because it is sufficient to distribute a single base frequency in place of the several individual harmonic frequencies needed for carriers in modulation. The objective is to decentralize carrier supply to the extent that small cross-section terminals become more economical, without significant cost penalty at the heavy cross-section terminals.

It is essential that multiplex equipment of new design be compatible with that of older design because, in the normal process of plant extension, it will sometimes be necessary for a new terminal to work with one of older design at the opposite end of the high-frequency transmission medium. Even when new and old designs of terminal are used in juxtaposition in the same office, they must be operationally alike to facilitate maintenance and enable service restoration in emergencies. At the expected high rates of future production, however, the penalty of compromise in the new design to retain compatibility would apply to an indefinitely large number of units, whereas reasonable modification of older equipment to resolve incompatibility will apply to a definite number of units already in plant.

An example of deliberate acceptance of incompatibility to be resolved by modification of the older plant is the new frequency allocation for Supergroup No. 1. The Bell System standard frequency allocation for Supergroup No. 1 has been the band from 68 to 308 kilocycles, and it is being changed to a new standard allocation from 60 to 300 kilocycles. This will result in additional guard space between the upper edge of Supergroup No. 1 and the lower edge of the basic supergroup, which eases substantially the design requirements on band filters for Supergroup No. 1. It is estimated that the long-term savings in filter cost for new terminals due to the change in frequency allocation will be greater than the total cost of modification of plant in service in a reasonably short time, and that substantial savings will accrue beyond that time. In addition to economy, there should also be an intangible advantage in minimizing conflict between frequency allocations standard in the Bell System and those recommended internationally.

A second example of incompatibility accepted for resolution by modification of plant in service is the use of a single transmitting cable from channel bank to group equipment. Hybrid-derived dual outputs have been provided at the transmitting carrier frequency side of A-type channel banks for test access and to facilitate in-service patching of group equipment. The hybrid coil has been an integral part of the channel bank with both outputs cabled from there to the high frequency patch bay. A single cable will be used by locating a miniature hybrid coil in the high frequency patch bays of existing installations and in the new transmitting multiplex bays. The use of a single transmitting carrier cable will result in significant reduction in cost of installation for each new channel bank, and these savings are expected to more than counteract the expense of modification where older type channel banks are to be used with the new multiplex. In addition to long-term

CHAPTER 11 L CARRIER TERMINAL

economy, there will be considerable relief from office cable congestion, a matter of increasing concern and expense to the operating companies. The use of single cable also enables the design of a compact group distributing frame, a new equipment item that is needed urgently to reduce the time and expense of necessary plant rearrangement to accommodate growth and changing pattern of traffic.

Another important area of study is concerned with the operational integration of standard wideband data service with basic telephone message service. Study to date of the latter area has already led to the decision to change the standard frequency allocations of the terminal pilots of the L-type multiplex. At present, a 92-kc pilot is used to monitor the transmission of each group, and the Group 3 pilot translated to 424 kc is used to monitor each supergroup. These choices are satisfactory for message service in that pilots are located near the center of the band they monitor and correspond to zero frequency or 4000 cycles per second in adjacent message channels. Since message service does not require the transmission of frequencies close to either of these extremes, the pilots do not interfere with message service and allow in-service measurement and adjustment of group and supergroup with minimum reaction on service. When the wider bands are offered for data service, however, the presence of a pilot near the center of the band is a serious restriction. This presents a basic conflict of interest in that a pilot is considered essential to good maintenance and yet its presence near the center of the band is a deterrent in standard wideband data service. The conflict has been resolved by agreement to move the pilots close to the edges of the wider bands, using 104.08 kc for group pilot and the Group 1 pilot translated to 315.92 kc to monitor supergroup transmission. These choices appear to sacrifice 4 kc of available bandwidth but the actual waste is much less because delay distortion impairs the band edges so that they would not be of much value in data transmission. The offset of 80 cps from an exact multiple of 4 kc is planned to obviate the need for an expensive crystal filter to guard against interference from channel carrier leak. It is recognized that changing the entire Bell System plant to new standard-frequency allocations for terminal pilots will incur substantial expense to convert existing equipment. Nevertheless, integration of wideband and message service is considered essential to future efficient use of the plant, and present indications are that a major part of the cost of conversion will be recovered in filter savings resulting from the use of an offset frequency.

The new family of L-type multiplexes will enable the operating telephone companies to meet efficiently the need for modern communications over the coaxial cable and radio plant of the Bell System. Significant reductions in space and power requirements along with regulation and other operational advantages are made available for slightly lower first cost of installed equipment. Long-term economy should result from improved service due to more effective maintenance with less expenditure of effort.

CHAPTER 11 L CARRIER TERMINAL

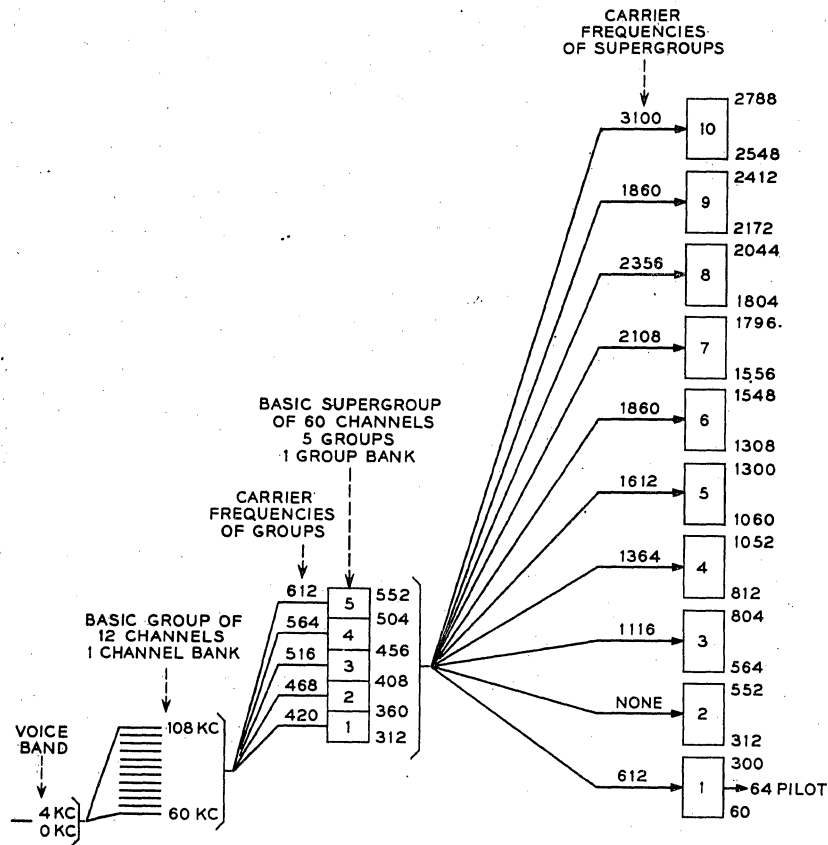

Fig. 11-2 - Frequency allocation - L600 multiplex.

11.7 FREQUENCY ALLOCATION

Two types of terminals have been developed, the L600 for multiplexing up to 600 voice channels, and the L1860 for multiplexing up to 1860 voice channels. The L600 is used as terminals for TD-2, TJ, and TL microwave radio relay systems and the L1 coaxial cable system. Its frequency allocation is shown in Fig. 11-2. The L1860 is used for L3 coaxial and TH radio systems. As indicated on Fig. 11-3, the L1860 employs different supergroup carrier frequencies for certain supergroups and requires the mastergroup stage of modulation. Equipment arrangements for smaller numbers of circuits are also being provided; these are the L60 and L120, for 60 and 120 channels, respectively.

The frequency allocations shown on Fig. 11-2 agree with those used on the L1 system telephone terminals except for that of Supergroup 1. The band shown, 60-300 kc, is 8 kc lower in frequency than that used in the L1

CHAPTER 11 L CARRIER TERMINAL

terminals. The new allocation permits the use of filters for Supergroups 1 and 2 which do not contain quartz crystals, which were previously required. The new Supergroup 1 carrier is the same frequency as the Group 5 carrier, 612 kc, permitting some simplification in carrier supplies.

The continued use of 64 kc as a pilot frequency for microwave radio systems and for synchronization of carrier supplies makes it necessary to provide a 64-kc band-elimination filter in the transmitting Supergroup 1 to clear a band for the pilot.

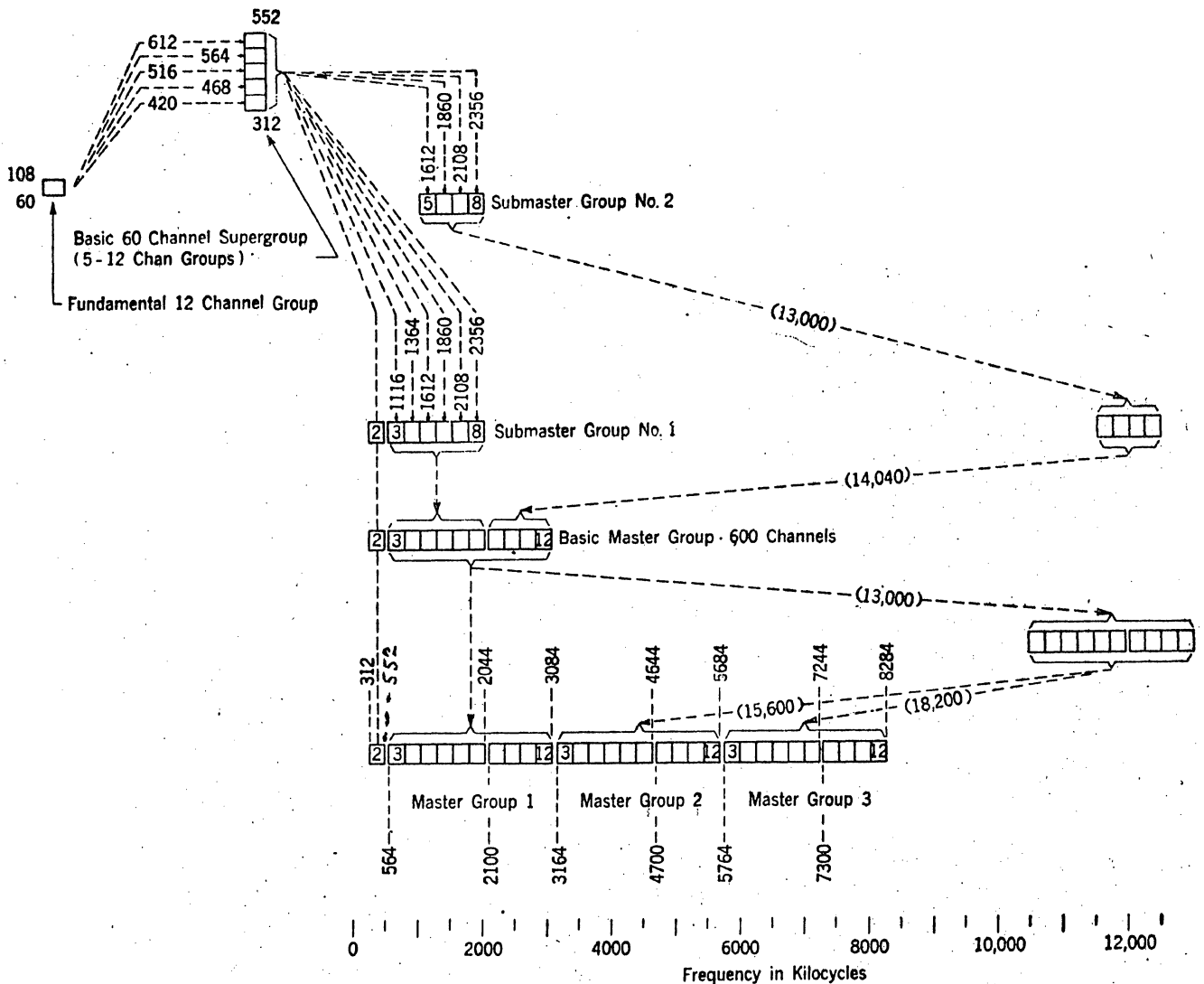

Fig. 11-3 - Frequency allocation - L 3 System

CHAPTER 11 L CARRIER TERMINAL

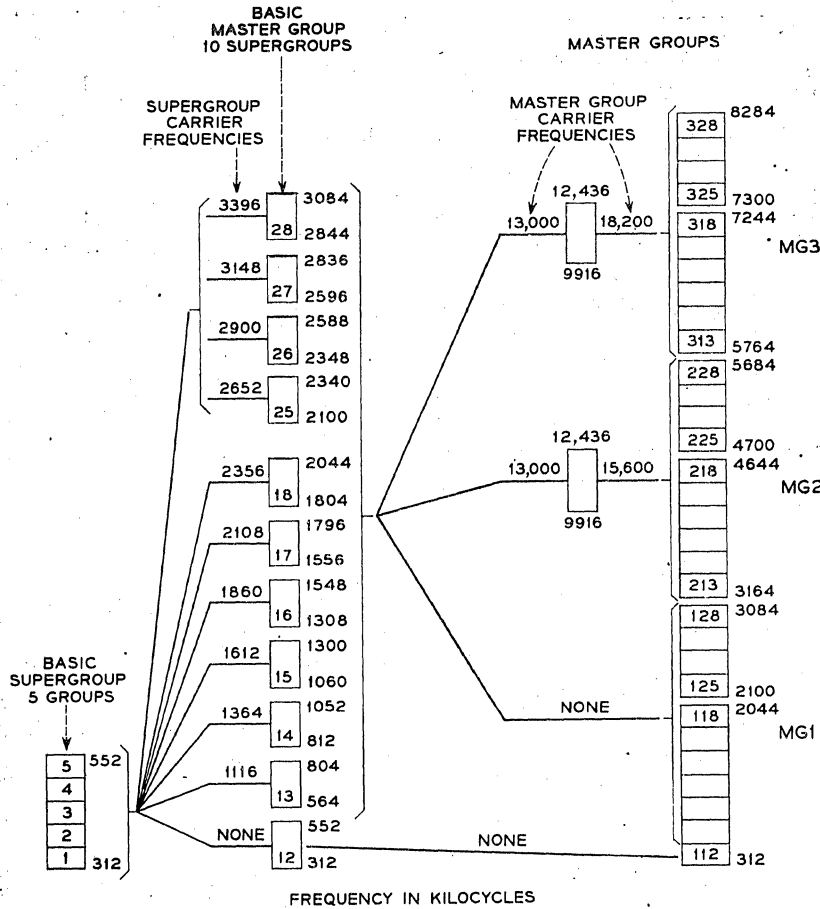

Fig. 11-4 - Frequency allocation - L1860 multiplex.

The L-3 Carrier System was designed to operate over a broader frequency band than the L-1 system. This design provides for a maximum of as many as 1860 two-way telephone channels in the frequency range between 312 and 8284 kc. As shown in figure 11-3, ten 60 channel supergroups are modulated with appropriate carriers to form a master group of 600 voice channels. The first master group is placed in the frequency range between 564 and 3084 kc., the second between 3164 and 5684 kc., and the third between 5764 and 8284 kc. In addition, a single supergroup may be transmitted below master group No. 1 in the basic supergroup range of 312 to 552 kc.

The plan used to obtain the basic mastergroup for the L1860 multiplex, shown on Fig. 11-3, differs from that used in the L3 system telephone terminals. The four supergroups numbered 25 to 28 are modulated directly to their basic mastergroup allocations instead of using three stages of modulation. The earlier plan required fewer supergroup carrier frequencies and fewer filter designs. However, with the use of the mastergroup terminals for both L3 coaxial system and TH radio system, it becomes economical to supply the additional carriers and filters designs in order to eliminate the sub-mastergroup stages of modulation.

CHAPTER 11 L CARRIER TERMINAL

11.8 TRANSMITTING CIRCUITS

The block schematic on Fig. 11-5 shows the group and supergroup circuits. The output of the transmitting portion of the channel bank is connected to terminals on the transmitting group distribution frame, and through the frame to the pilot insertion equipment on the group and supergroup transmitting bay. The 92-kc elimination filter clears a pilot channel between two voice channels. It is required to suppress the carrier leak at 92 kc which would interfere with pilot operation. The 92-kc group pilot is introduced through a hybrid transformer. The output including the pilot is fed to a second hybrid transformer which provides two equal outputs. One of these is connected through normal contacts on jacks to the transmitting group equipment. The second output is available for monitoring or emergency patching.

If the terminal is retransmitting a group that has been received from an incoming system, the group signal is transmitted through a group connector including a bandpass filter, the group distribution frame and the pilot insertion equipment. If it is desired to operate with a through pilot, a pad is substituted for the pilot elimination filter and pilot hybrid transformer.

In small offices the group distribution frames may be omitted and the connections made directly from channel banks or group connectors to the group equipment.

A transmitting group amplifier is combined with the group modulator in a single plug-in assembly. The lower sideband of the modulator output is selected by a bandpass filter. The filters for the odd-numbered groups have their outputs in parallel. Similarly, the two even-numbered group filters are paralleled. The two sets of outputs are added in a hybrid transformer. The entire band from 312 to 552 kc (5 groups) is amplified in the transmitting intermediate amplifier. A low-pass filter to suppress out-of-band harmonic products follows, and two equal outputs are provided by a hybrid transformer.

Each group bank output is modulated by an appropriate carrier, and one sideband is selected by a band-pass filter. An exception is Supergroup 2, which is not modulated, but transmitted directly. As with the group filters, the odd-numbered supergroup filters have their outputs paralleled on one side of a hybrid transformer and the even-numbered on the other side. One output of the hybrid transformer is normally terminated but can be used for monitoring. The second output is patched to a terminal trunk for connection to the transmitting system for the L600 multiplex. When two or three mastergroups are to be combined in an L1860 multiplex, the supergroup bank output is amplified by a transistor feedback amplifier with a gain of 26 db.

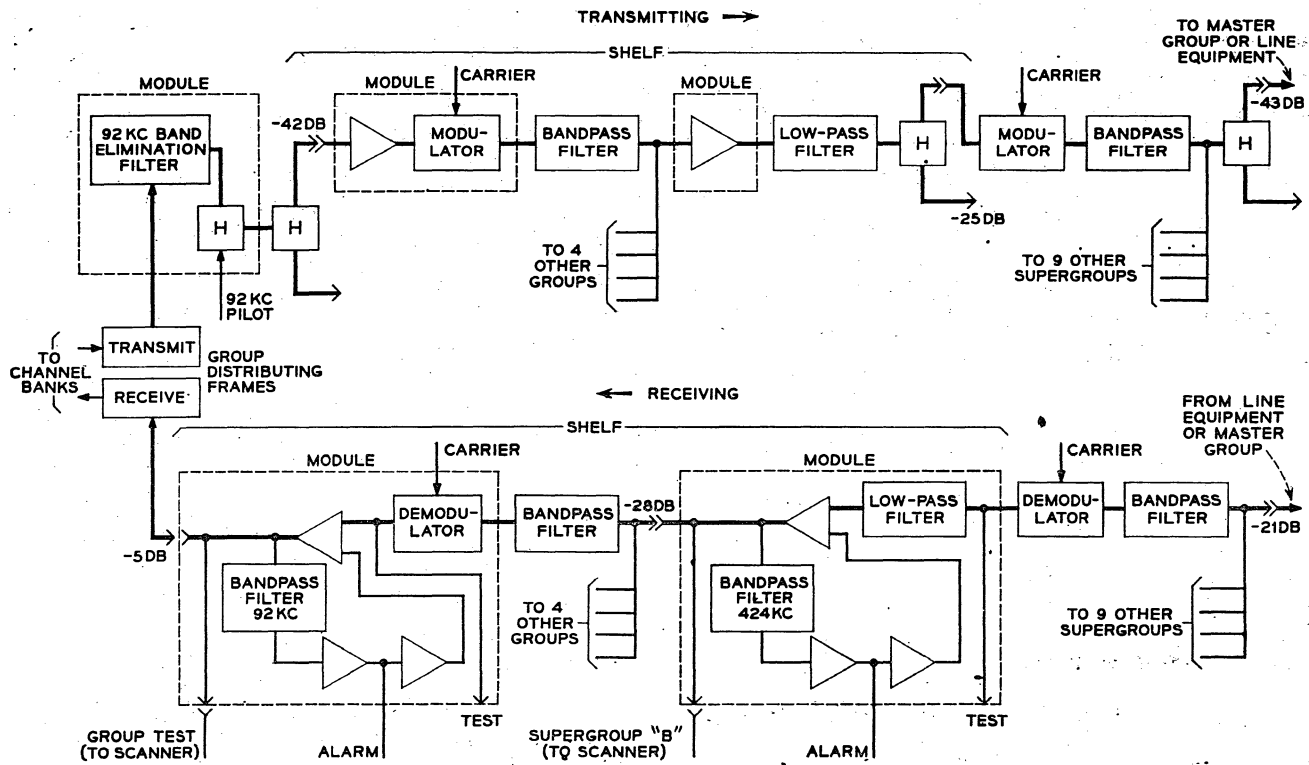

11.12

Fig. 11-5 Block schematic of group and supergroup circuits. The indicated levels are for one voice channel, referred to zero transmission level.

CHAPTER 11 L CARRIER TERMINAL

11.9 RECEIVING CIRCUITS

At receiving terminals the baseband signal is received from the radio terminals or the mastergroup equipment. It is separated into supergroup bands by filters, and all except Supergroup 2 are demodulated to the basic supergroup band, 312-552 kc. Each supergroup signal is amplified by a regulated amplifier similar to that of the receiving group except that the Group 3 pilot at 424 kc is used to control the regulator.

The receiving group equipment accepts the 312-552-kc band from the supergroup equipment and separates it into group bands by filtering. The output of each group filter is demodulated to the basic group band, 60-108 kc. The lower sideband is selected by a low-pass filter and amplified. The gain of the amplifier is controlled by a regulator operated by the 92-kc pilot. This maintains the pilot at the output of the amplifier at a substantially constant level. Since the gain of the amplifier is constant over the group band, the regulation compensates for any flat level deviation that may occur in the transmission circuit, at either terminal, or in the connecting system.

The main output of the group amplifier is connected through normal contacts on jacks to the receiving group distribution frame and through it to the receiving portion of a channel bank or to a group connector. A second output of the group amplifier is connected to a scanner circuit and a pilot alarm circuit. These circuits will be described in later sections.

11.10 REGULATORS

In the L1 and L3 terminals, group pilots at 92 kc are added at the transmitting terminals. These are used for circuit monitoring and for periodic manual adjustment of receiving group gain controls. The pilot in Group 3, 424 kc, is used for adjusting the supergroup gain control. With the increased complexity of the toll plant, in which some group circuits may be connected through several different transmission systems and several sets of terminals via group or supergroup connectors before reaching the receiving channel bank, small deviations in level frequently accumulate. With the more stringent requirements of Direct Distance Dialing and data transmission, it has become difficult to achieve satisfactory performance with manual adjustments.

Continuous adjustment of receiving supergroup and group gain by pilot-controlled regulators offers substantial improvement. After considerable field experience with experimental and prototype regulators installed in L1 terminals, it was decided to include both group and supergroup regulators in the new terminals.

CHAPTER 11 L CARRIER TERMINAL

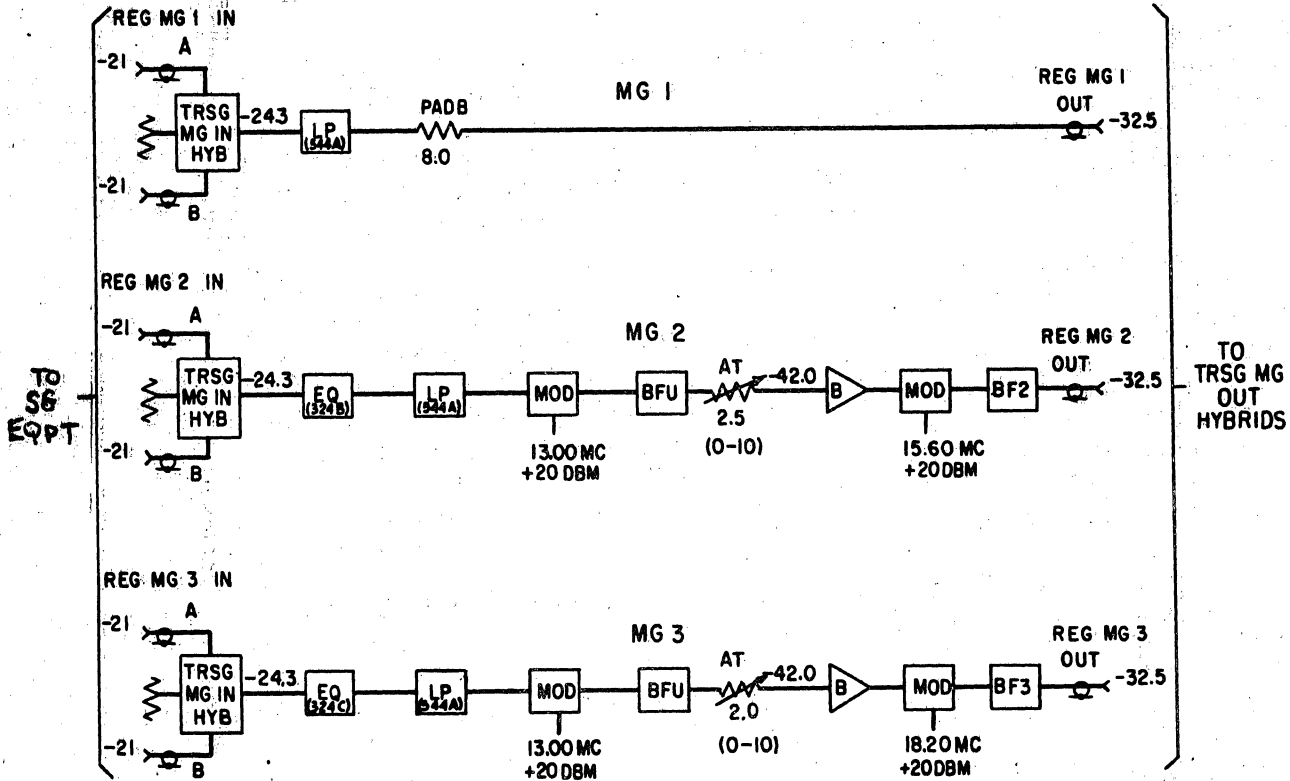

Fig. 11-6 - Block Schematic of Transmitting Master Groups

11.11 MASTER GROUP TERMINAL CIRCUITS

A complete 1860 channel all message terminal requires three transmitting and three receiving master groups. These are designated as MG 1, MG 2, and MG 3. The terminal is so arranged that any or all master groups can be used if required. If only master group 1 is installed for initial use, either or both of the remaining master groups can be added later without interruption of service if the combining hybrids have been provided on the initial installation.

The transmitting master groups provide the means for placing the frequencies received from their associated submaster group banks into their proper positions in the line-frequency spectrum. The output from a basic master group of 10 supergroups passes, without modulation, through master group 1 to become the lower portion of the line-frequency band. Modulators in master groups 2 and 3 translate the frequencies received from other basic master groups, to their higher frequency portions of the line spectrum. The function of the receiving master groups is the reverse,

CHAPTER 11 L CARRIER TERMINAL

that is, to select from all of the line frequencies only those required by their associated supergroup banks. The higher line frequencies selected by master group 2 and master group 3 are demodulated in two steps to provide the proper frequency bands for the associated receiving supergroup banks. Two steps of modulation and demodulation are used in master groups 2 and 3. Figs. 11-6 and 11-7 show the block schematic and level diagram of the transmitting and receiving master group circuits.

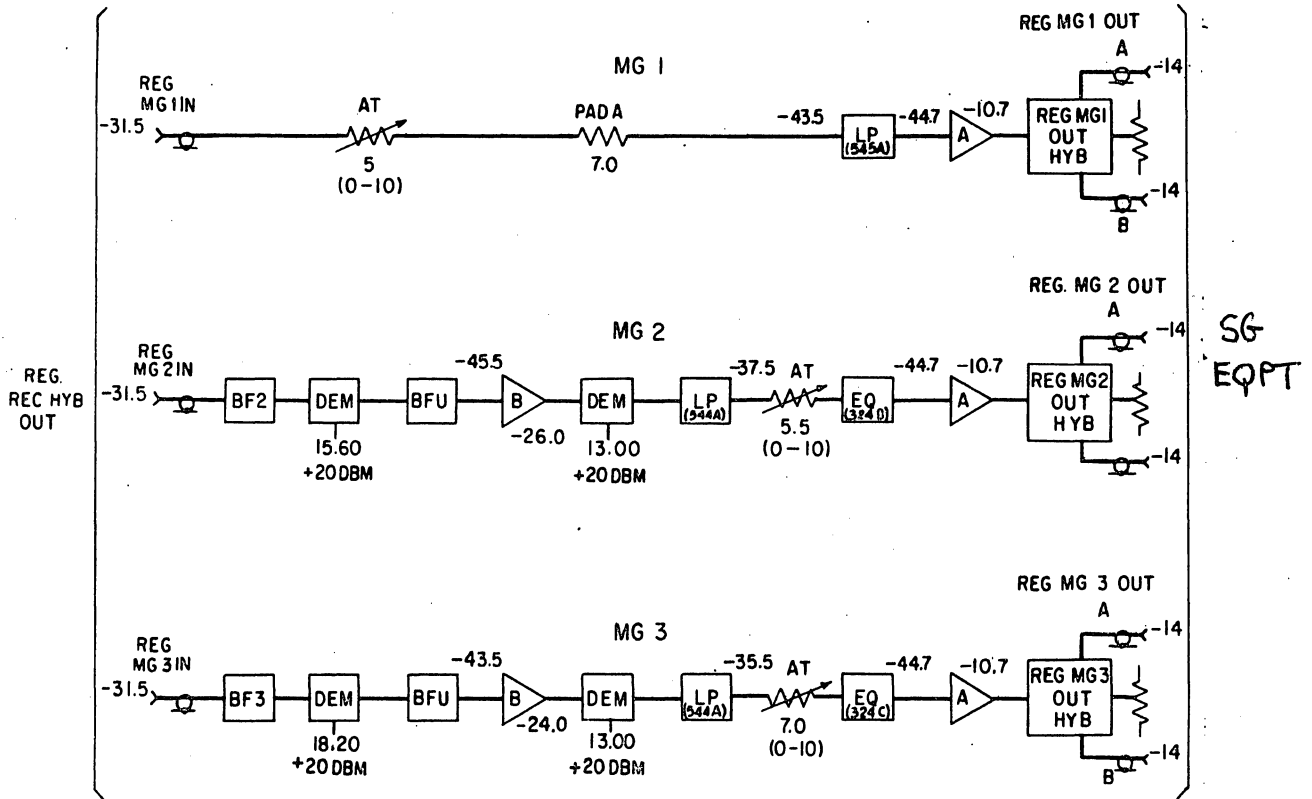

Fig. 11-7 - Block Schematic of Receiving Master Groups

11.12 L4 SYSTEM

A new coaxial cable system employing transistor repeaters with a capacity of 3600 voice channels on each coaxial pair is being developed for Bell System use. The L4 System is expected to meet the need for more long haul circuits and to obtain better utilization of the coaxial cable. The continuous development of high frequency transistors has resulted in devices which are satisfactory for use in wideband repeaters. The contributions of system engineering, outside plant, power plant, network design and systems design groups have resulted in many innovations in the new system.

CHAPTER 11 L CARRIER TERMINAL

The repeater spacing for the L1 system using 0.375 inch coaxials averages 7.5 miles, and for the L3, about 4 miles. The L4 System average repeater spacing has been set at 2 miles in order to make the maximum use of repeater sites in converting existing routes to the new system. The L4 System, like the L1 and L3, will use amplitude-modulated single-sideband transmission of voice channels employing the L-Multiplex terminal equipment supplemented by a new mastergroup multiplex.

The line frequency allocations are shown on Figure 11-8. The mastergroup (600 voice channels) has become the standard block for long haul circuits in the Bell System. The six mastergroups are separated by guard bands to permit dropping and blocking any one mastergroup at a main station without demodulating the others. This feature will reduce the amount of terminal equipment used at dropping points and decrease the number of terminals required in tandem for long circuits.

New television terminals for the L4 system may be developed later, but initially it is planned to use those developed for the L3 System. The frequency allocation will be the same as L3, with the television band replacing mastergroups 2 and 3. Field testing will be required to determine the number of mastergroups which can be transmitted simultaneously with the television signal, as a function of distance.

A main pilot is located at 11.648 mc, in the guard band between mastergroup 4 and 5. This location was selected in preference to lower frequencies to avoid interference with the television band. A synchronizing pilot for the multiplex terminals is located at 512 kc.

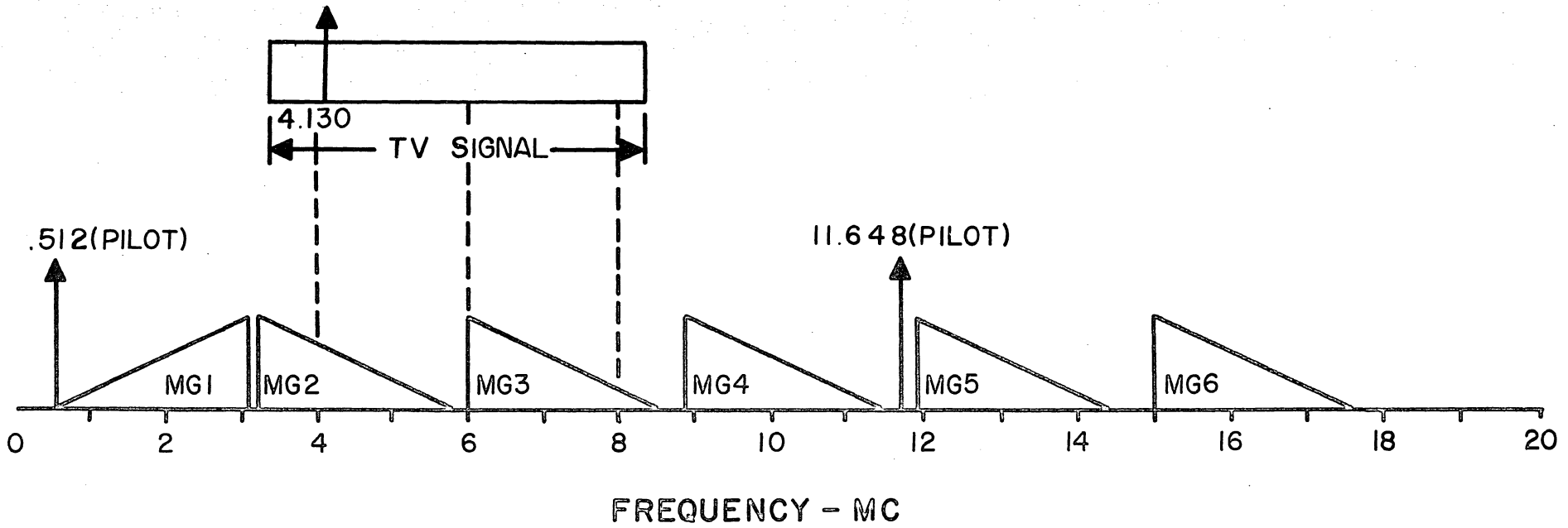

Fig. 11-8 - L4 Frequency Allocations
 (Note that upper sidebands of message channels are transmitted in all MG except MG 1)

CHAPTER 12

L CARRIER TRANSMISSION LINE

12.1 COAXIAL CONDUCTORS

Our consideration of transmission lines thus far has been confined to lines made up of two parallel wire conductors. An entirely different configuration of conductors may be used to advantage where high, and very high, frequencies are involved. This configuration is known as coaxial and the conducting pair consists of a cylindrical tube in which is centered a wire as shown in Figure 12-1. In practice the central wire is held in place quite accurately by insulating material which may take the form of a solid core, discs or beads strung along the axis of the wire or a spirally wrapped string. In such a conducting pair equal and opposite currents will flow in the insulated central wire and the outer tube just as equal and opposite currents flow in the more ordinary parallel wires.

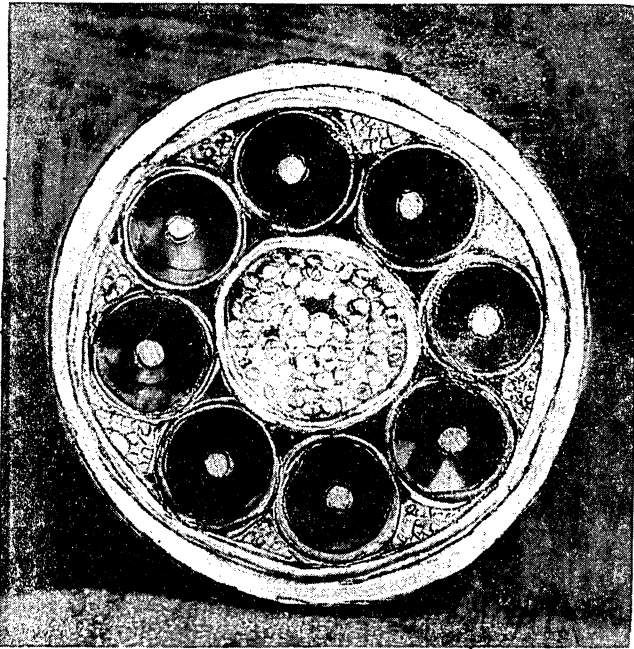

Fig. 12-1 (a) Coaxial Cable Cross Section

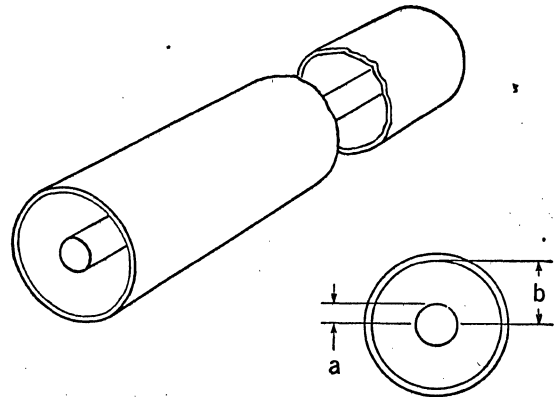

Fig. 12-1 (b)

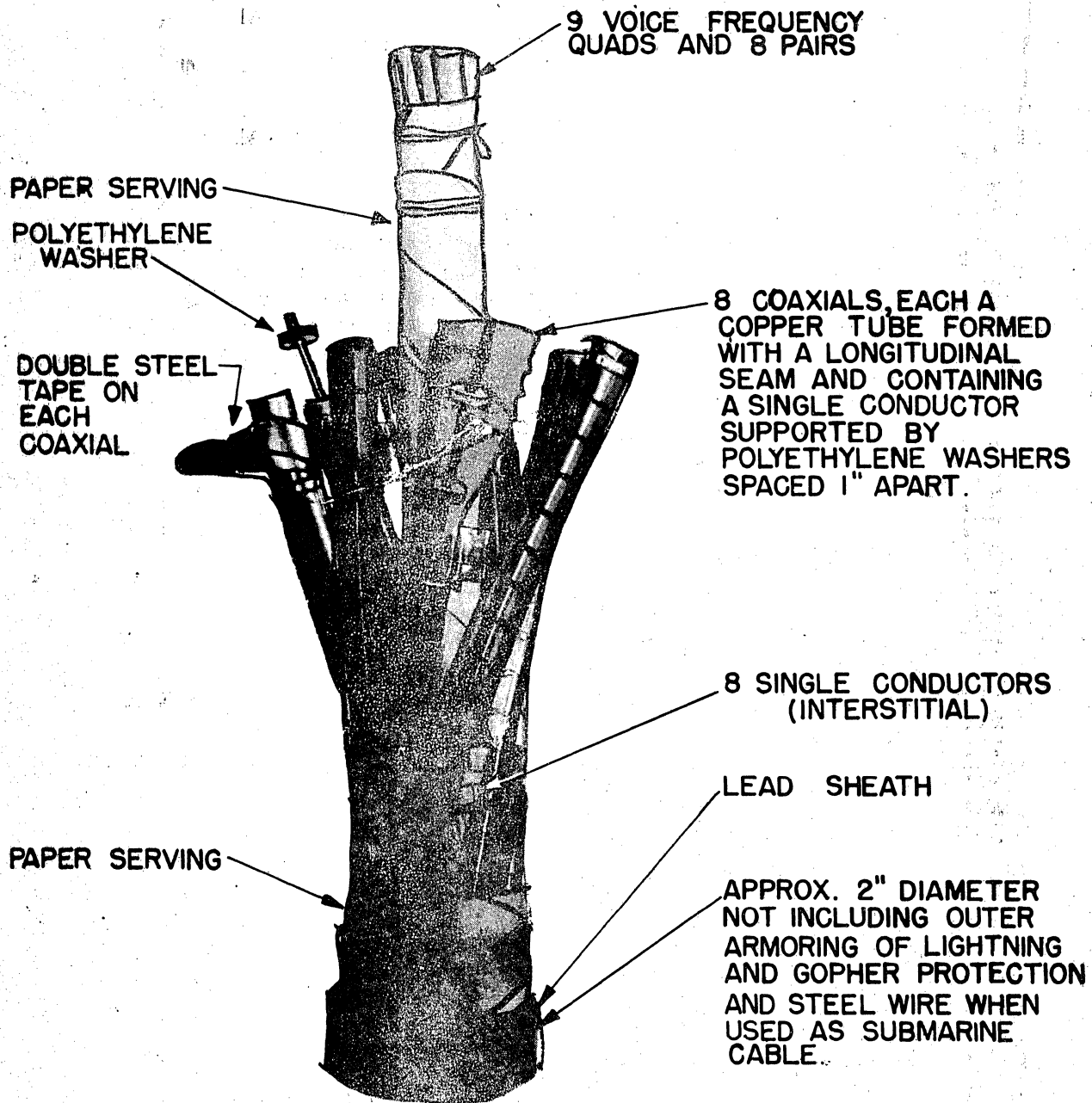

Fig. 12-1 (c) An 8 - Coaxial Cable

CHAPTER 12 L CARRIER TRANSMISSION LINE

At high frequencies, a unit length of coaxial in which the dielectric loss in the insulation is negligible (effectively gaseous) will have an inductance which is about one-half the inductance of two parallel wires separated by a distance equal to the radius of the coaxial tube. The capacitance of the same coaxial is approximately twice that of two parallel wires separated by the same distance and having the same diameter as that of the central coaxial conductor. If the outside radius of the central conductor is designated a and the interval radius of the tube is b , the characteristic impedance at high frequencies neglecting leakage may be shown to be approximately -

$$Z_o = \sqrt{\frac{L}{C}} = 138 \log \frac{b}{a} \quad (12:1)$$

The attenuation constant per mile, where both conductors are of the same material, varies as the square root of frequency and is approximately -

$$\alpha = \frac{R}{2Z_o} = .24 \times 10^{-4} \frac{\sqrt{f} \left(\frac{1}{a} + \frac{1}{b} \right)}{\log \frac{b}{a}} \quad (12:2)$$

where a and b are in centimeters. From equation (12:2) it may be determined that minimum attenuation is obtained when the coaxial is so designed that $b/a = 3.6$. With this configuration Z is about 77 ohms. The present standard coaxial used for transmission in the Bell System employs a copper tube .375 inches in inside diameter and a copper center wire .1004 inches in diameter. This, it will be noted, approximates the optimum ration specified above for minimum attenuation. The nominal impedance is about 75 ohms. Velocity of propagation in the coaxial approaches closely the speed of light. A study of the basic characteristics of the coaxial shows that at the high frequencies assumed, the attenuation is substantially less than that of a parallel wire line of comparable dimensions. More important is the fact that the shielding effect of the outer cylindrical conductor prevents interference from external sources of electric energy being transmitted over the coaxial. Although the coaxial cables have no cutoff frequency, the attenuation for high frequencies becomes so great that the repeaters must be placed very close together. There is, therefore, an upper frequency range above which it is uneconomical to transmit with the equipment and methods available. In the "L" Carrier Systems this spacing is every 8 miles for L-1, every 4 miles for L-3, and every 2 miles for L-4.

CHAPTER 12 L CARRIER TRANSMISSION LINE

12.2 L CARRIER SYSTEM REPEATERS

General

The word "repeater," as used in this section, is an all-inclusive term embracing the components, installed at any one location, necessary to provide for the satisfactory transmission of the frequencies employed in the L1, L3 or L4 system. Each carrier system requires two coaxials, one in each direction, for 2-way transmission and each system has its own individual components, i. e., power separation filters, basic equalizers, amplifiers, equalizers, regulations, pilots, etc.

Repeaters can be divided into two general classes: those that receive power from the cable and those that obtain power locally. The first group includes the auxiliary and equalizing auxiliary repeaters. The second group includes the equalizing main, the switching main, and the terminal repeaters. Main and terminal repeaters usually contain a power plant which transmits a constant ac power current to feed auxiliary and equalizing auxiliary repeaters.

Auxiliary Repeater (L1 & L3)

The auxiliary repeater provides 2-way amplification and regulation which produces a gain characteristic closely equal to the loss of 8 miles of 0.375 inch coaxial cable for L1 and 4 miles for L3.

Equalizing Auxiliary Repeater (L3 only)

The equalizing auxiliary repeater is basically the same as the auxiliary repeater, however, it also includes fixed, dynamic, and manually adjustable equalization required to reduce unequalized deviations introduced by a number of auxiliary repeaters to the desired value.

The Equalizing Auxiliary Repeater provides supplemental equalization for approximately 32 auxiliary repeater sections and is powered from the cable.

Equalizing Main Repeater (L3 only)

The Equalizing main repeater is the same as an equalizing auxiliary repeater except that it has facilities for supply power to adjacent power sections.

CHAPTER 12 L CARRIER TRANSMISSION LINE

Switching Main Repeater (L1 and L3)

The Switching Main is the same as an equalizing main plus providing facilities for automatically switching to the standby line when necessary. It also has additional dynamic and manual equalization to further reduce accumulated deviations in the line freq. band. This makes line as flat as possible facilitating switching to a standby line. It will also provide delay equalization for combined MSG. & TV transmission.

The L1 System also has non-switching mains and branch pts. for dropping some circuits and passing others.

Terminal Repeater (L1 and L3)

The Terminal repeater is substantially the same as a switching main repeater but all facilities are modulated down to at least supergroups (and vice versa) and with all line pilots introduced.

Basic Repeater (L4)

The principal parts of the basic repeater are two power separation filters, a preamplifier, a line building-out network, a power amplifier, and a voltage regulator diode. The line building-out networks are constant resistance networks having an insertion loss corresponding to that of a specified length of coaxial line in 0.1 mile steps from 0.1 to 1.0 miles. These will be used when required to adapt the fixed gain of the repeater to the loss of the associated cable sections. A signal-to-noise advantage is obtained by locating the network between the two amplifiers instead of in front of the preamplifier. By the use of these networks in the repeaters at both ends of a repeater section, sections as short as one mile can be accommodated. An occasional section as long as 2.5 miles can also be used by locating shorter repeater sections on each side of it to maintain the 2.0 mile average.

The performance of the repeater is dependent to a large extent on the transistors available for use in the amplifiers. Two new types of silicon planar transistors were developed for this use. The first has an f_T of about 950 mc, a low frequency common emitter short circuit gain of about 150, and a noise figure at 17 mc of about 4.5 db with a bias current of 20 ma. It is used for the first stages of the preamplifier and the power amplifier. The high bias current has been found necessary, even for these stages, to reduce intermodulation.

The second type is a medium power transistor with an f_T greater than 700 mc and low frequency gain of about 50. It is mounted on a beryllia header for good heat transfer. With the case temperature held at 25°C,

CHAPTER 12 L CARRIER TRANSMISSION LINE

collector dissipation of 5 watts or more can be used without shortening life. This transistor is used for the output stage of the preamplifier and the second and third stages of the power amplifier.

Regulating Repeater (L4)

In addition to the parts which are in common with the basic repeater, a third amplifier is added to the regulating repeater which is similar to the power amplifier except for the feedback network. A thermistor-controlled variable equalizer is incorporated in the shunt branch to correct for changes in cable loss with temperature. The amount of this correction is controlled by a pilot regulator which monitors the power of the 11.648 mc pilot through a hybrid transformer. At the normal pilot power, the amplifier has a constant gain of 13 db at all frequencies in the band. A fixed deviation equalizer corrects for the average gain deviation of the basic repeaters in the preceding regulating section.

The second half of the repeater contains a second variable equalizer which makes a preliminary correction for change in cable loss due to temperature for the following regulating section. The thermistor of this equalizer is controlled by the resistance of a thermistor buried near the cable at a short distance from the repeater. This method is used to reduce almost by half the misalignment in transmission levels which would occur by operating both equalizers from the pilot.

12.3 EQUALIZATION

The equalization of wideband coaxial systems for long haul service requires several steps of increasingly complex equalizers. The L3 system employs six pilots across the band, each controlling the adjustment of a variable equalizer. Manually adjustable equalization is provided by 15 terms of cosine equalizers and 6 additional equalizers providing greater control over portions of the band. The manual equalization is adjusted on an out-of-service basis by switching the message traffic to the spare line facilities, and using a swept-band technique for determining the optimum adjustment of the cosine equalizers.

The increasing use of message channels for data transmission makes it desirable to avoid unnecessary line switches which may introduce errors. Equalization for the L4 System is being designed for in-service adjustment, at least for those equalizers which will need frequent adjustment. The general equalization for random deviations will be based on groups of adjustable "bump" equalizers, each introducing a bell-shaped gain frequency characteristic. Such equalizers are used in the L1 System and in a recent French system. The equalizer adjustment can be determined and changed on an in-service basis by measuring test tones which are not in message channels.

CHAPTER 12 L CARRIER TRANSMISSION LINE

The use of transistor repeaters is expected to reduce the amount of change in gain with time compared with systems employing electron tubes. Initially, only the main pilot at 11.648 mc will be used to control continuously adjustable equalizers located at the regulating repeaters as described in the previous section. If later experience shows it to be desirable, one or two additional pilots at the band edges can be used to control equalizers at main stations or at equalizing repeaters.

It is desired that equalizing repeaters be unattended and present plans are to install the repeaters underground. The equalizers are arranged for remote control from the adjacent main station by using thermistors as the control element in each equalizer and by a memory circuit for each which supplies a constant heater current for the thermistor. The magnitude of the current can be changed by commands from the main station when required. The local memory, or "holding" circuits make it unnecessary to have continuous signals from the main station to control the equalizers.

The commands to change equalizer settings are transmitted as audio tones modulating carriers in special channels located in the 300 to 500 kc frequency band.

To enable the operator at the main station to determine the optimum equalizer settings, six crystal oscillators with constant output power are installed with each equalizing repeater. These oscillators can be switched to inject their outputs at the six test frequencies into the pipe being equalized, on command from the main station. By measuring the power of the test signals at the main station as the oscillators are switched on and off from successively more remote locations, the optimum changes in settings can be computed.

Five binary counter stages are used in each memory unit, providing a reversible memory with 32 states. The readout is converted to a current supplied to the heater of each thermistor. The long time constant of the thermistor makes the transition during adjustment gradual, so that data transmission within the mastergroup bands will not be affected.

At main stations, in addition to 6 adjustable equalizers which duplicate those in the equalizing repeaters, nine more equalizers will be provided, which will be adjusted using test frequencies located between mastergroups or in the guard band within each mastergroup which separates the sixth and seventh supergroup.

CHAPTER 13

TYPE "N" CARRIER SYSTEMS

13.1 INTRODUCTION

In the late 1940's, because of increased cost of cable facilities and the need for more toll facilities resulting from the intertoll dialing program, the need for an inexpensive short haul carrier system became obvious. In many areas, half the toll circuits are 35 miles or less in length and only a very few are over 200 miles in length. If the longer exchange trunks are included, the proportion of shorter circuits is even greater. If a carrier system is to be economically feasible for these short circuits, the per channel cost must be lower than the per channel cost for voice frequency circuits over additional cable facilities.

Existing carrier systems (K, L etc.) could not meet this cost requirement. Since the maximum length of the circuit would not exceed 200 to 300 miles, many cost reducing designs were feasible. (200 miles of N carrier is about the equivalent of 1,000 miles of K2 carrier for circuit quality). The minimum length of circuit that could utilize N carrier, produced at a lower cost than the voice frequency loaded cable and repeaters, depends upon many factors.

For example, if the N carrier is to be used over existing cable and the additional voice frequency circuits will require new cable facilities, the carrier will be economical for lengths as short as 15 or 20 miles. However, if new cable facilities are not required in either case, the carrier would not be economical for distances less than 35 miles. Where costs are about even, the transmission advantages favor the carrier.

13.2 GENERAL

The N2 carrier system employs transmitted carrier double sideband transmission with channels spaced every 8 kc. For most installations, 12 channels, numbered 2 to 13, transmit carriers at 8 kc intervals from 176 kc to 264 kc (high group) in one direction of transmission, and at 40 kc to 128 kc (low group) in the opposite direction of transmission. Fig. 13-2 shows an N2 terminal. A channel 1 is available for use in place of any other channel which may be unavailable because its frequency band is used for wideband data service, or is unsatisfactory due to interference. Channel 1 may also be used as a maintenance spare to temporarily replace any channel in trouble because of a defective modem unit. Use of channel 1 as a maintenance spare reduces the required stock of spare equipment.

CHAPTER 13 TYPE "N" CARRIER SYSTEMS

Channel 1 has a 168 kc carrier for high-group transmission and a 136 kc carrier for low-group transmission. All carrier channels are generated and detected in the high-group range to simplify filters and other elements. However, since they may be transmitted over the line at either high-group or low group frequencies, a low-group range is obtained by group modulation with 304 kc carrier, the lower sideband being selected by filters. When low-group frequencies are received, they are modulated with a 304 kc carrier and filtered to select the lower sideband to obtain the high-group frequencies required by the channel demodulators.

The N2 carrier terminal equipment is intended for use with either N1 electron tube or transistorized repeaters, or with N2 transistorized repeaters (when available). Power for repeaters may be fed out as direct current over the simplexes of the same two cable pairs which transmit the carrier signals. When electron tube repeaters are used, power may be fed to one repeater adjacent to a terminal. When using transistorized repeaters, power may be fed to as many as the first three repeaters along a route. Accordingly, N2 terminals are arranged to provide +130 volts and -130 volts for power feed to electron tube repeaters or -48 volts and ground, +130 volts and ground, -48 volts and +130 volts, or +130 volts and -130 volts for power feed to transistorized repeaters.

N2 carrier terminals are arranged for use only with inband external E-type single-frequency signaling. Automatic trunk conditioning equipment, including the carrier group alarm circuit (CGA), and CGA signal receiver must be associated with each terminal and the E-signaling equipment associated with it. The message channels using channel positions A and B must be connected to the E-signaling units at the carrier terminal offices. These units and the CGA signal receivers at the terminals are required to control the service restoral control circuit in the carrier group alarm equipment. Other message channels may or may not be associated with signaling. The carrier group alarm equipment is located in miscellaneous bay space outside the terminal bay. The CGA signal receiver is located in an E-type signaling unit bay. Either 4-wire terminating circuits, included in some E-type signaling units or separate 4-wire terminating sets may be used with N2 carrier channels depending upon circuit requirements. Fig. 13-1, is a line diagram showing typical interconnection of N2 carrier terminal bays carrier group alarm equipment, CGA signal receiver, and E-type single-frequency signaling equipment, and the optional use of 4-wire terminating sets and voice-frequency patch bay equipment.

A complete N2 carrier terminal requires not only a part of a shop-wired terminal bay with associated plug-in units but also two or more E-type signaling units, a carrier group alarm (CGA) unit, a CGA signal receiver and numerous trunk circuits. For the purposes of this practice, trunk circuits are defined as connections to switching circuits, subscribers lines or VF extensions to other offices. They may be 2-wire or 4-wire with or without 4-wire terminating sets, but each may be reached via

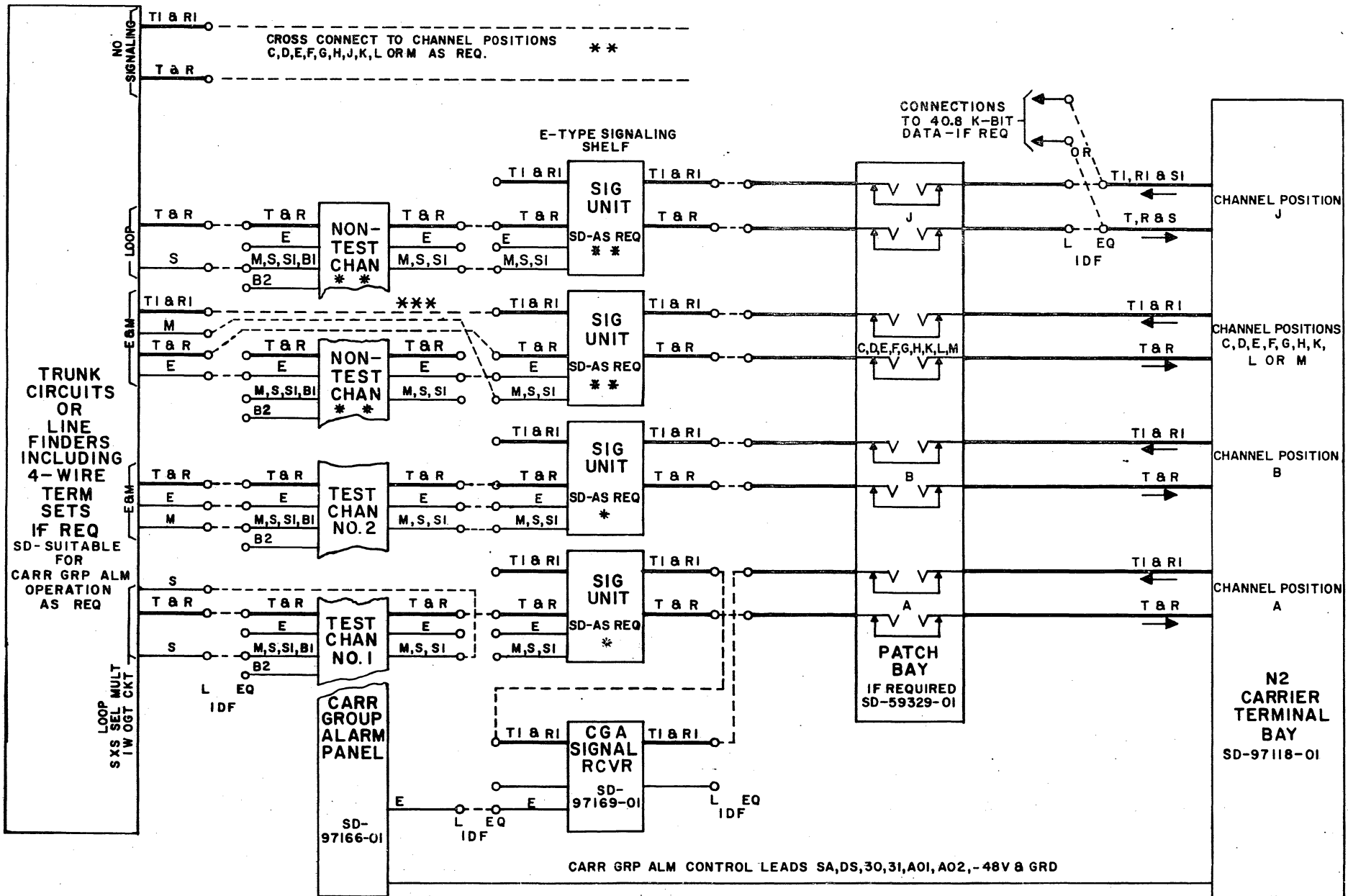

* SIGNALING UNITS ARE ALWAYS REQUIRED FOR CHANNEL POSITIONS A & B.

** SIGNALING UNITS AND ASSOCIATED SECTION OF CARR. GRP. ALM. ARE BY-PASSED AT THE IDF FOR CHANNEL POSITIONS C TO M NOT REQUIRING TRUNK CONDITIONING OR SIGNALING AT THE N2 TERMINAL OFFICE.

***-RUN THESE T1 & R1 CONNECTIONS WHEN REQUIRED FOR 4-WIRE OPERATION.

--- CROSS CONNECTION WIRES.

Fig. 13-1 Line Diagram - N2 Carrier Terminal

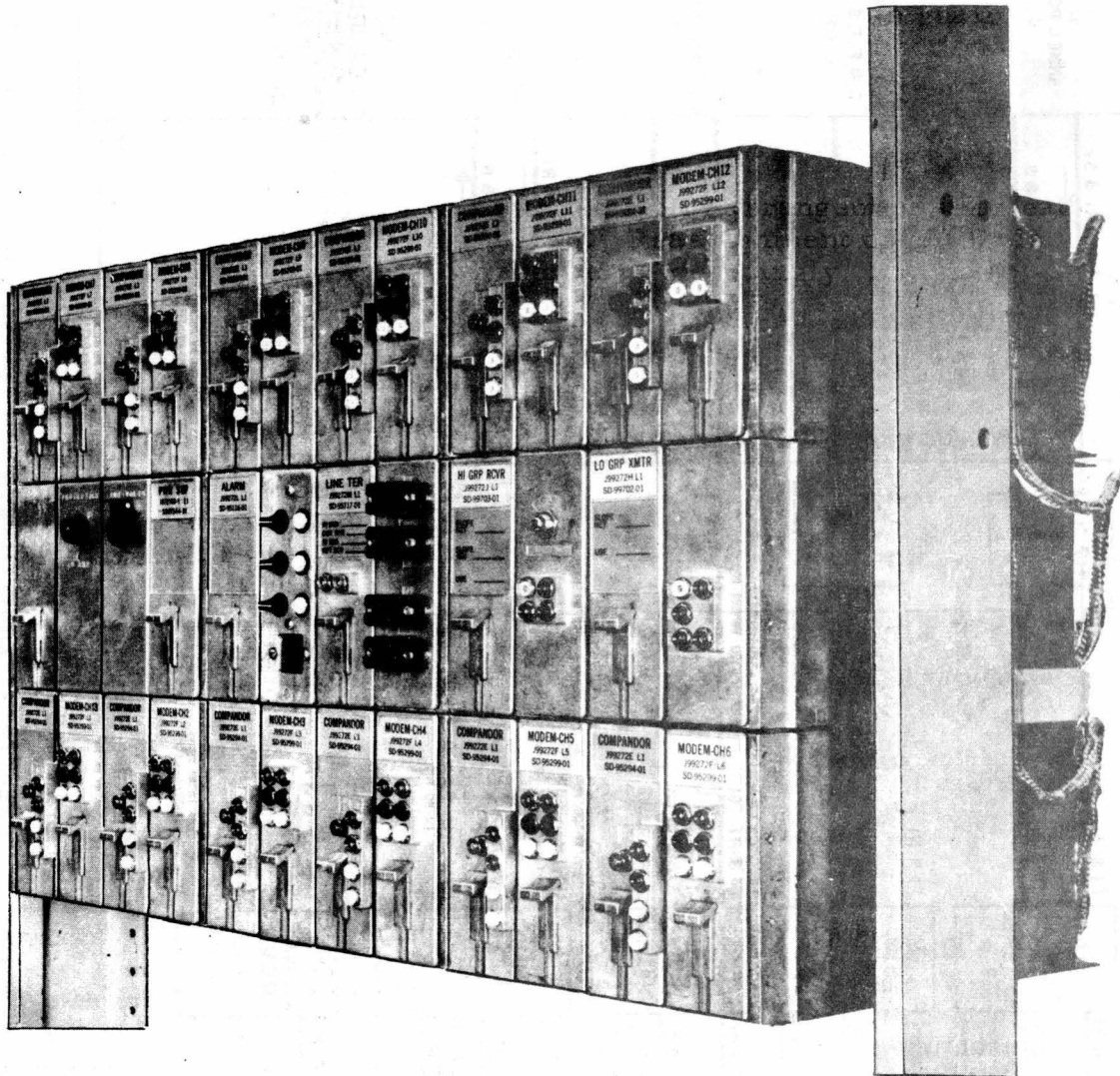

Fig. 13-2 N2 Carrier Terminal - Front View

suitable transmission and signaling connections at a distributing frame. The circuit derived from each of the twelve channel positions in an N2 terminal may be used for a wide variety of purposes. The circuit may require different types of plug-in units, different types of E signaling units (which may be omitted), and connections through or around sections of the CGA unit as well as different trunk circuits.

13.3 FLEXIBILITY AND CROSS CONNECTIONS

It is seldom possible to predetermine the specific arrangements for each channel when an installation is engineered. Reassignment of channels from time to time is a common occurrence. Accordingly, the main

CHAPTER 13 TYPE "N" CARRIER SYSTEMS

circuits are connected to a distributing frame by universal cabling so that they may be interconnected or bypassed by suitable cross-connections. This and optional strapping at terminal blocks on the CGA make possible office engineering and subsequent assignment or re-assignment of channels to services and trunks without additional engineering or installer effort. Fig. 13-1 illustrates typical interconnections between channel positions and trunk circuits.

The compressor input leads (T & R) and the expander output leads (T1 & R1) of channel positions A to M in the N2 terminal bay are connected to the distributing frame (IDF) either directly or via a patching and monitoring bay when centralized testing and interchange of carrier channels is desired. Connections to channel position J are shielded and always are connected direct to the IDF and then to the patch bay if it is desired.

The input (T1 & R1) and output (T & R) leads on the line side of the E-type signaling units are also connected to the IDF. In like manner, the line and equipment side connections to the CGA signal receiver are connected to the IDF. As illustrated in Fig. 13-1, both line and equipment connections are T1 and R1 leads corresponding to 12-wire universal cabling to the E-type signaling positions. If the office uses 7-wire or 8-wire cabling, the leads from the CGA signal receiver to the EQ block on the IDF would be designated T & R rather than T1 and R1, but they would be cross-connected to T1 & R1 leads on the L block for the E-type signaling unit in test channel 1. This flexibility between channel positions and E-type signaling units facilitates rearrangements for purposes such as the following:

- (a) omission of signaling units on channel position C to M arranged for through signaling, program or other special services,
- (b) reassignment of E-type signaling unit positions to accommodate new types of signaling such as E1L-A and E1S-A, and
- (c) use of the CGA signal receiver on test channel 1.

It should be noted that the cabling to and from E-type signaling shelves may not meet the transmission requirements of some of these services and routing through connectors plugged into E-type signaling unit shelves would not be desirable.

The equipment side of each E-type signaling unit position is connected to an EQ block on the IDF by T & R and two supervision leads E and (M, S, S1, etc.). The line side of each test channel or nontest channel block on the CGA unit is connected to an L block on the IDF by T & R, E and (M, S, S1) leads. One or more of these leads may be cross-connected to an E-type signaling unit as required by the type of trunk circuit, type of signaling unit and test or nontest assignment of the channel. In many

CHAPTER 13 TYPE "N" CARRIER SYSTEMS

assignments, some of these leads are cross-connected to trunk circuits and routing via CGA unit would not be satisfactory for transmission and/or supervision reasons. Only the leads requiring CGA processing in the particular assignment are routed through the CGA unit. An example in Fig. 13-1 is the T & R and M leads for the nontest channel with E & M signaling. It may be noted in the example used for test channel No. 1 that in some instances, the CGA S lead at the L block on the IDF is cross-connected to an S lead on the trunk circuit rather than to an S lead on the EQ block for an E-type signaling unit, i. e., the S leads of the CGA are in series with two parts of the trunk circuit.

Each test or nontest channel block on the CGA unit is connected to an EQ block on the IDF by T & R, E, (M, S, S1, B1) and B2 leads. There are only five leads from each CGA block but one of them has multiple designations as shown in Fig. 13-1. In some assignments, all five leads are cross-connected to a trunk circuit but in other assignments, as few as one lead may be used. Use of channel positions C to M for message channels without signaling, program or some special services, require direct cross-connection from the EQ block on the IDF associated with the N2 terminal channel positions and the L block on the IDF associated with the trunk circuit. These connections are illustrated at the top of Fig. 13-1.

In many assignments such as nontest channels when E and M lead supervision is used, the T & R leads and the M lead do not require processing in the CGA unit. Accordingly, cross-connections are often required from the EQ block on the IDF associated with the E-type signaling units to the L block on the IDF associated with the trunk circuits. 4-wire to 4-wire signaling units such as E1B, E2B, and E3B, use T1 and R1 leads which do not require processing in the CGA and are cross-connected directly to the trunk circuit as shown on a nontest channel in Fig. 13-1.

In locations where signal LINE and EQ jacks are wired in the E and M leads, these jacks would be wired on the equipment side of the CGA circuit (if used) or on the equipment side of the E-type signal unit.

As previously discussed, the input and output pairs (T & R and T1 & R1) for channel position J are used alternately for message or 40.8 kilobit data service and are shielded. When used for data these leads should not be routed through a patching and monitoring bay. This would be undesirable for transmission and operating reasons. Accordingly, the T, R & S (shield) and T1, R1 and S1 (shield) leads of channel position J are connected to an EQ block on the IDF. They may be cross-connected to 40.8 kilobit data circuits, to patching and monitoring jacks or signaling units as desired. It is expected the use of some N2 systems will involve frequent changes between 40.8 kilobit and message use. This involves interchanging N2 plug-in units. Provision of patching jacks in the 40.8 kilobit circuit would permit patching and testing at the location of the 40.8 kilobit equipment. In such an arrangement, both the channel position J and the patching bay

CHAPTER 13 TYPE "N" CARRIER SYSTEMS

leads would be cross-connected to the 40.8 kilobit data equipment and cross-connection changes would not be required during switching from data to message use. Fig. 13-3 is a block diagram of an N2 terminal arranged for message use.

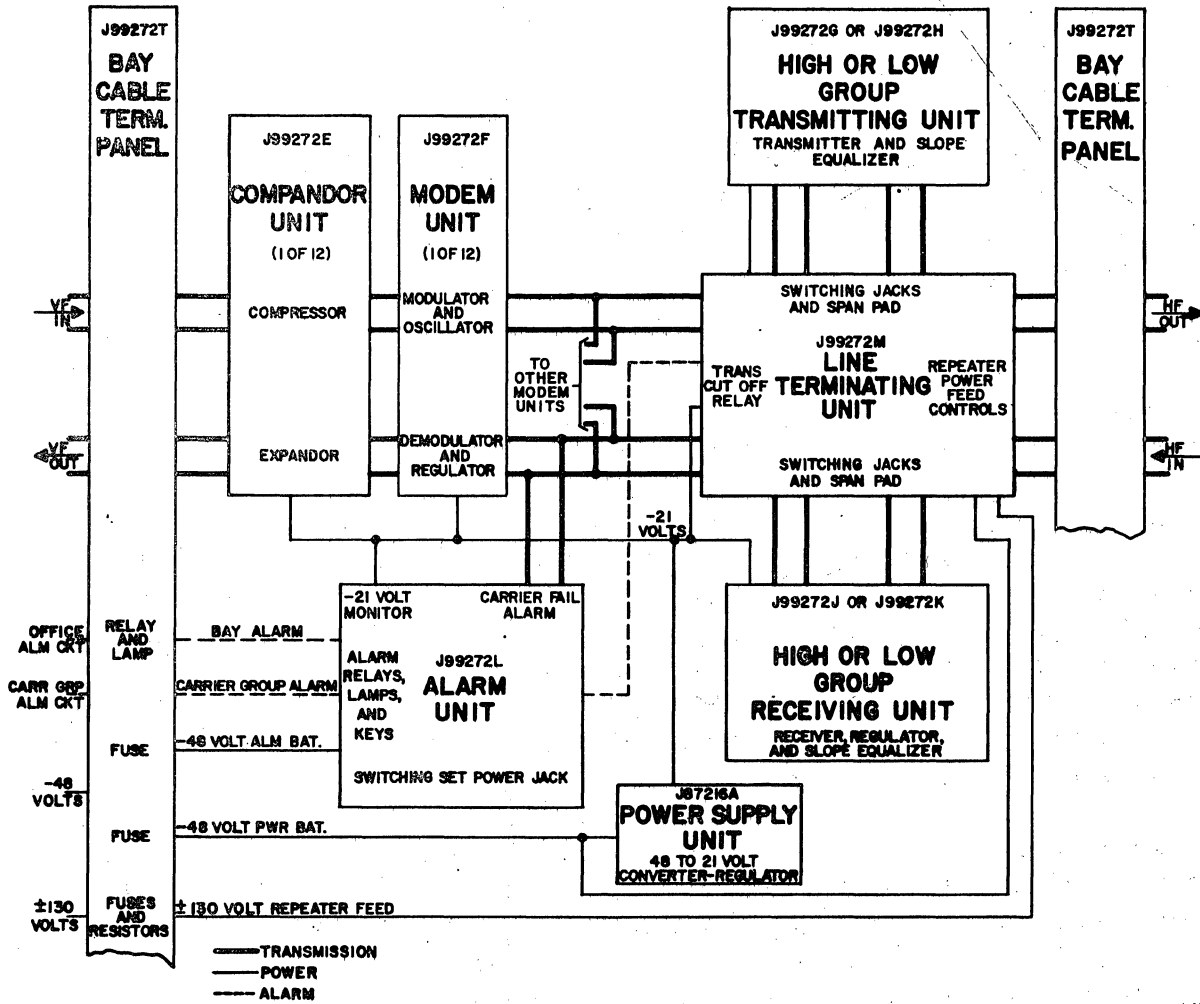

Fig. 13-3 Block Schematic - N2 Carrier Terminal Arranged for Message Use

13.4 CHANNEL PLUG-IN UNITS

Compondors

Each compandor consists of a compressor at the transmitting end of the circuit and an expander at the receiving end. The compressor functions by compressing the range of speech volumes at the input to a range approximately one-half as great at its output. This means that for every 2 db. change in the input speech volume, its output changes only 1 db. This action is such that the weaker speech is raised in volume (thereby obtaining improvement in its relation to noise and crosstalk picked up on the N channel between the compressor and the expander) and the louder speech (which already has a favorable relation to noise and crosstalk) is practically unchanged.

At the far end of transmission, the expander which receives the compressed speech reestablishes the original volume range, by expanding the input range of volumes to a range twice as great. For every 1 db change in input, the expander output changes 2 db. The action is such that the weaker inputs are reduced in strength and the louder inputs undergo relatively little change. Thus noise and crosstalk, which at the expander input are moderately low with respect to speech volumes, are reduced in strength in the interval between speech bursts, so that a more favorable relationship of speech to interference is obtained.

Compondors have been designed into the N Carrier System in order to take advantage of the economies effected by their use. They improve the relationship of message to crosstalk and noise in the transmission medium. The system is designed so that a signal of +5 dbm at zero level ahead of the compressor will also produce +5 dbm at a zero level in the compressed portion of the circuit (between compressor and expander) and also at a zero level point at the output of the expander. Briefly stated, a +5 dbm signal is unaltered by either compressor or expander.

The diagram of Fig. 13.4 illustrates the essential features of the compandor action with relation to signal levels. The diagram shows a compressor and an expander connected by a transmission medium. Signal strengths throughout are indicated. The +5 dbm input power very nearly represents the power in the speech of the strongest talker and it passes through the compressor without alteration or with unity transmission. Now as the input signal is reduced a given number of db, the signal after the compressor is reduced only half this number of db. For example, an input signal of -20 dbm at zero level (a reduction of 25 db from the reference +5 dbm) becomes -7.5 dbm at zero level following the compressor (a reduction of only 12.5 db from the reference +5 dbm).

CHAPTER 13 TYPE "N" CARRIER SYSTEMS

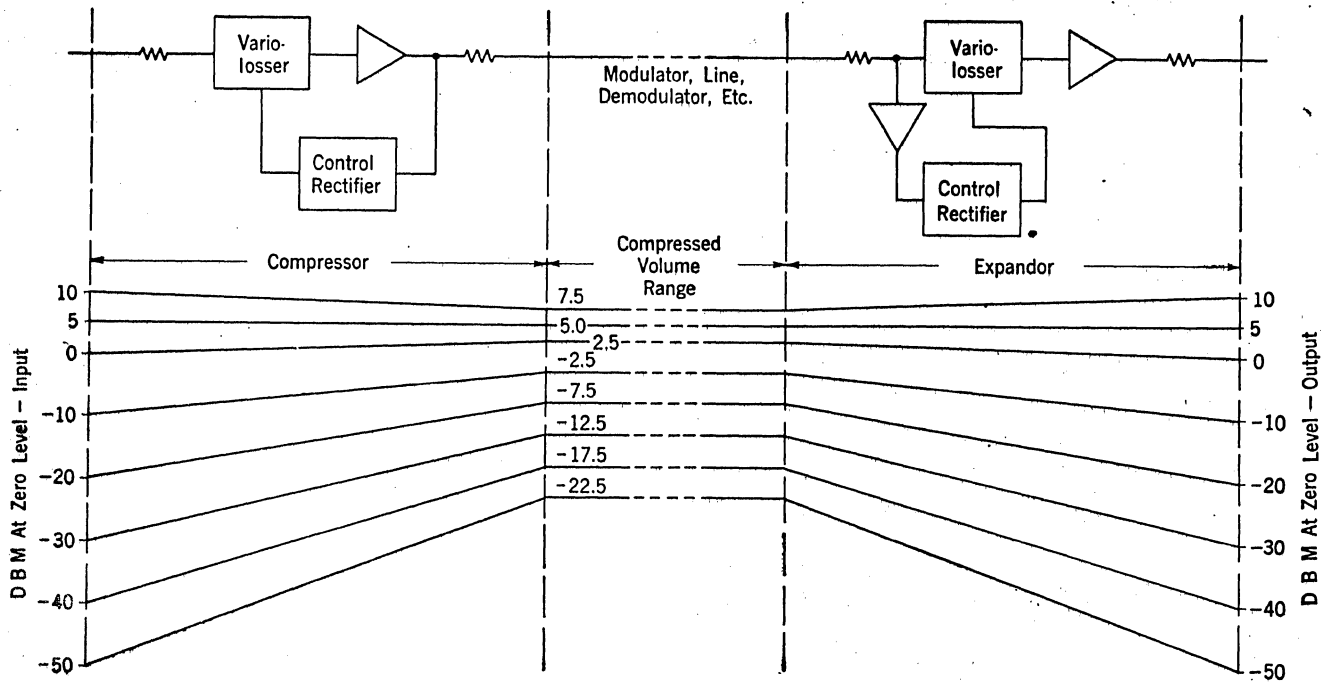

Fig. 13-4 - Compandor Action on Signal Levels

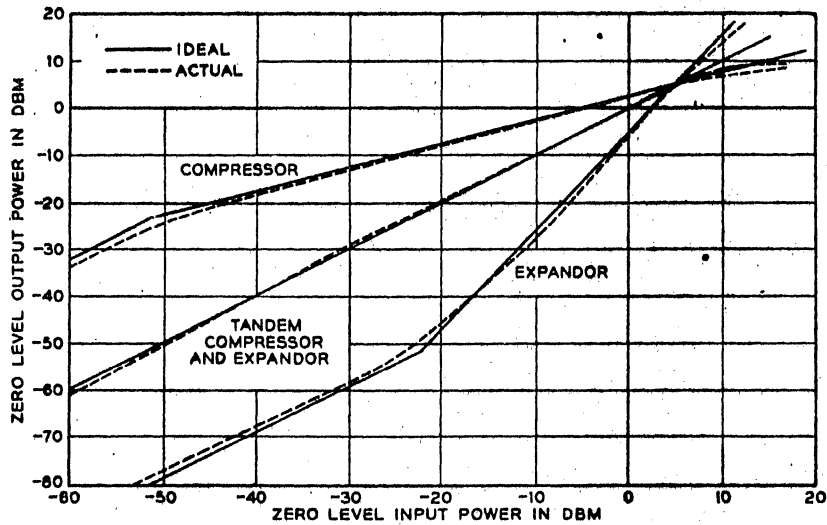

Fig. 13-5 - Input-Output Load Characteristics of N Compandor

Figure 13-4 illustrates the increased amplitude of weak signals relative to the strong signals resulting from compressor action. This permits the transmission of these weaker signals over lines with severe noise conditions that would otherwise make transmission intolerable. Another chart illustrating compressor performance is shown in Figure 13-5. The solid line compressor curve shows an input-output characteristic of an ideal compressor. For ease of illustration zero levels have been taken for input and output.

CHAPTER 13 TYPE "N" CARRIER SYSTEMS

The load line shows a 2 for 1 characteristic down to an input of -51 dbm where the compressor becomes linear. This is called the knee of the compressor characteristic. The compressor output at the knee of the characteristic is -23 dbm. This point represents the maximum benefit that can be given to weak signals; signals which without a compressor would go out at -51 dbm now are transmitted at -23 dbm, a signal to noise improvement of 28 db.

Message Compressor

The message compressor unit, is a single-module wide plug-in unit which is required for each terminating message channel. The units used for all channels are identical. Included in this unit are:

- (a) A compressor circuit which reduces the volume range of the voice-frequency signal before modulation in the transmitting terminal.
- (b) An expander circuit which restores the volume range of the signal after demodulation in the receiving terminal.

The expander unit includes an output adjustment potentiometer which is accessible on the face of the unit. Four pin jacks are provided on the face of the unit for use with test equipment to monitor and measure the level at voice-frequency input and output. These pin jacks may also be used for a 52K headset when an out-of-service channel is used for a temporary talking circuit.

Message Modem

The message channel modem unit, is a single-module wide plug-in unit which is required for each channel (except program channels). There are 13 different units, one for each channel frequency. Each modem includes two complementary devices, a modulator circuit and associated oscillator, and a demodulator circuit and associated regulator. The modulator circuit receives voice-frequency signals from the compressor and translates them to a double-sideband carrier-frequency signal in an 8 kc band within the high-group frequency range of 164 to 268 kc. The demodulator circuit selects its specific 8 kc wide channel from the 12 high-group carrier channels received from the group receiving unit. Then the selected channel signals pass through a regulating amplifier to the demodulator and are modulated down to voice frequency for transmission to the expander. A complete terminal may be equipped for 12 channels, generally utilizing channels 2 through 13. Channel 1 may be substituted for any one of these channels. Test points are provided on the face of the channel modem unit for use in measuring:

- (a) modulator input level (voice)
- (b) modulator output level (carrier)
- (c) level at the output of the receiving channel band filter (carrier)
- (d) demodulator output level (voice)

CHAPTER 13 TYPE "N" CARRIER SYSTEMS

Schedule C and D Program Units

Schedule C and D program compandors and modems may be used instead of message compandors and modems in channel positions C to M. They cannot be used in channel positions A or B because they are not compatible with the signaling associated with those positions. The 21-volt power required for these units is approximately the same as that of the placed message channel units. Schedule C and D program channels may be located at carrier frequencies for channels 3, 4, 5, 6, or 7 if N2WM-1 data service is not required. Only channels 3 and 4 may be used for schedule C and D program if N2WM-1 data service is required.

The compandor unit for schedule C and D program, is a single-module plug-in unit equipped with a 20 contact plug and card assemblies of apparatus components. This compandor is suitable for either schedule C and D program or message service. Included in this unit are: (1) a compressor circuit which reduces the volume range of the voice-frequency signal before modulation in the transmitting terminal and (2) an expandor circuit which increases the volume range of the signal after demodulation in the receiving terminal. The expandor circuit includes an output adjustment potentiometer which is accessible on the face of the unit. Four pin jacks on the face of the unit are provided for use with test equipment to monitor and measure the voltage at the voice-frequency input or output, or for connection to a 52K headset when an idle channel is used for a temporary talking circuit.

The modem unit for schedule C and D program, is a single-module plug-in unit equipped with a 20 contact plug and card assemblies of apparatus components. There are five separate modem units, one for each carrier frequency channels 3 to 7. Each modem unit includes two complementary devices, a modulator circuit and associated oscillator and a demodulator and associated regulator. The modulator circuit receives voice-frequency signals from a compressor and translates them to a double sideband carrier frequency signal in an 8 kc band within the high-group frequency range 180 to 220 kc. The demodulator circuit selects its specific 8 kc wide channel from the 12 high-group carrier channels received from the group receiving unit. The selected channel then passes through the regulating amplifier and is demodulated down to voice-frequencies for transmission to an expandor. Six pin jacks on the face of the unit are provided for use in measuring (1) modulator input level (voice), (2) modulator output level (carrier), (3) level at the output of the demodulator input band filter (carrier), and (4) demodulator output level (voice).

VF Amplifier

The VF amplifier, is a single-module plug-in unit interchangeable with a compandor unit as regards size, external connections and power requirements. It includes separate transmitting and receiving amplifiers. Potentiometers designated IN ADJ and OUT ADJ control the gain of the

CHAPTER 13 TYPE "N" CARRIER SYSTEMS

amplifiers and are accessible in the face of the unit as are pin jacks which may be used to monitor the voice-frequency input and output of the channel position. This unit may be used in place of any message compandor unit in channel positions C to M when compandor action is not desired.

13.5 COMMON PLUG-IN UNITS

Group Units

The transmitting and receiving group units are 2-module wide plug-in units which provide the amplification, frequency translation, and filtering required in connecting the channel modem units to the line. Low-group transmitting and receiving units include a 304 kc oscillator and modulator because the modem units transmit and receive high-group frequencies only, whereas line frequencies may be either high-group transmitting and low-group receiving or low-group transmitting and high-group receiving. Through the use of the N2 switching set and paralleled connectors on the line terminating unit, group units may be replaced on an in-service basis. Test points are provided on the face of each group unit to facilitate various trouble location and performance tests. Each group unit includes an internal jack for a plug-in slope equalizer which may be changed as required to match the system terminal to line arrangements or conditions when they are changed. The face plate of each unit includes the words SLOPE NET with space for a pencil record of the plug-in slope equalizer used. Also, the setting of the small increment built-in slope adjustment for receiving group units may be indicated. This facilitates selection of the proper equalizer and setting for replacement units and units used in the switching set. A similar marking opposite the word USE will indicate wiring options for terminal or switching set use.

The plug-in slope equalizers are coded 364A, B, C, D, E, F, and G. They provide a group transmitting unit output slope of -9, -6, -3, 0, +3, +6, and +9, respectively, for channel 13 carrier power with respect to channel 2 carrier power. The 364-type equalizers are also used in the group receiver units for the same amounts of slope correction.

The high-group transmitting unit, is designed to receive signals from the channel modulators at high-group frequencies, reject unwanted frequencies, and amplify the desired signals to a suitable level for transmission over the carrier line. The desired output slope is obtained by inserting the appropriate 364-type equalizer. A wiring option is provided to increase the midband gain approximately 6 db when the unit is used in a switching set.

The low-group transmitting unit, is designed to receive signals from the channel modulators at high-group frequencies, translate them to low-group frequencies by modulation with a 304 kc carrier, and then amplify them to a suitable level for transmission over the carrier line. The desired output slope is obtained by inserting the appropriate 364-type equalizer. A wiring option is provided to increase the midband gain approximately 6 db when this unit is used in a switching set.

CHAPTER 13 TYPE "N" CARRIER SYSTEMS

The high-group receiving unit, receives the high-group frequencies from the carrier line, rejects unwanted frequencies, and provides proper slope equalization. A regulating amplifier automatically adjusts the gain to maintain a constant output power of combined carriers. The output of the unit is applied to the 12 channel receiving band filters. Coarse slope correction is provided by inserting the appropriate 364-type equalizer. Finer slope adjustment of +1, 0, or -1 db is built into the unit and controlled by the operation of a switch on the face plate. Optional wiring permits setting the unit at fixed gain instead of regulating gain when it is used in the switching set and during certain unit tests.

The low-group receiving unit, receives low-group frequencies from the carrier line, rejects unwanted frequencies, translates from low-group to high-group by modulation with a 304 kc carrier, provides slope equalization, and includes filtering for suppression of carrier leak and unwanted group sideband. A regulating amplifier automatically adjusts the gain to maintain a constant output power of combined carriers. The output of the unit is applied to the 12 channel receiving band filters. Coarse slope correction is provided by inserting the appropriate 364-type equalizer. Finer slope adjustment of -1, 0, or +1 db is built into the unit and controlled by operation of a switch on the face plate. Optional wiring permits setting the unit at fixed gain when it is used in the switching set or during certain unit tests.

Alarm Unit

The alarm unit, which is a 2-module wide plug-in unit, performs the following alarm, control, and service functions:

- (a) Monitors the received carrier signal and provides an alarm indication in the event of carrier failure.
- (b) Initiates and terminates automatic trunk conditioning in the event of system failure through alarm relay operation in association with the external E-type signaling unit, CGA signal receiver, and carrier group alarm equipment.
- (c) Includes a delay feature which prevents alarm indications from being given for very short duration carrier failures.
- (d) Monitors the output of the -21 volt power supply and provides an alarm indication of excessive voltage deviation or failure.
- (e) Provides for connection to office alarm systems through common bay alarm relays on the bay cable terminating unit.
- (f) Permits office alarm cutoff while retaining the local alarm indications by means of alarm release keys.

CHAPTER 13 TYPE "N" CARRIER SYSTEMS

- (g) Provides, by means of alarm override key in conjunction with external carrier group alarm equipment, for manual override of an alarm make-busy condition on selected channels, so they may be made good by external patching.
- (h) Provides for reoperation of the office alarms if alarm release keys are not restored when the alarm condition has been corrected.
- (i) Operates through a relay in the line terminating unit to interrupt transmitted carrier for a short time during the trunk conditioning cycle to initiate trunk conditioning at the distant terminal.
- (j) Provides a connector through which power may be connected to the N2 switching set for group unit or N2WM-1 unit switching and through which power may be supplied to the terminal from the switching set during power unit switching.
- (k) Short-circuits the voice-frequency output of channel position B under control of the CGA circuit during a part of the trunk conditioning cycle.
- (l) Originates an ESS first alarm signal when carrier fails (even momentarily), power fails or an alarm unit is removed from the bay. This option is used when an N2 terminal operates into switches of a No. 1 ESS office, to minimize pulse signaling or switch operation.

Line Terminating Unit

The line terminating unit, is a 2-module wide plug-in unit which connects the carrier frequency line pairs to the transmitting and receiving group units. It includes sockets for plug-in 38-type span pads which provide between 0- and 44-db attenuation in 2-db steps in both the transmitting and receiving directions. Voltage surge protection of group unit transistorized circuits is provided by varistors located in this unit. Simplexes for repeater power feed and longitudinal noise suppression are provided by a noise control transformer circuit for each carrier pair. The unit includes four switching jacks which are used in conjunction with the N2 switching set for in-service replacement of either group unit. These jacks also afford access for measurement of individual and total carrier powers. Also included is a relay which disconnects power from the transmitting group unit, under control of the alarm unit, during a part of the trunk conditioning cycle.

The line terminating unit includes provision for feeding power over the high-frequency line for sealing current and/or to power adjacent repeaters. Power feed options include ± 130 volts for one electron tube repeater or ± 130 volts, +130 volts and -48 volts or +130 volts and ground for one to

CHAPTER 13 TYPE "N" CARRIER SYSTEMS

three transistor repeaters. Battery feed resistors are distributed between this unit and the bay cable terminating unit at the top of the bay in such a manner that heat generated in the line terminating unit due to repeater feed circuits may be limited to about 5 watts to avoid unnecessary heating of transistor circuits in other plug-in units. The unit must be removed from the terminal for changes in span pads, power feed screw connections, or slide-wire resistor setting. Provision is made on the face of the unit for pencil notation of span pad values, screw connections in use, and the resistance setting of the slide-wire resistor. Pin jacks are provided on the face of the unit for in-service measurement of line current.

Power Supply

The -21 volt power supply, is a dc-to-dc transistorized converter operating from the -48 volt supply to provide a -21 volt regulated supply for the transistorized terminal equipment. One such power supply is required for each 12-channel terminal. It is a 4-module wide plug-in unit equipped with a 20-contact plug to mate with a connector in the terminal mounting. The face of the unit includes an output fuse and a control for manual adjustment of the output voltage.

13.6 N3 CARRIER

N3 Carrier is a 24 channel, four-wire short-haul cable system. Completely transistorized, it is designed to meet the stringent performance requirements for transmission of message, data and program over intertoll trunks. As a radio multiplex, up to 96 N3 Carrier channels may be accommodated on each micro-wave channel.

N3 Carrier supersedes the vacuum-tube operated ON2 system. Although N3 operates on the same frequencies over N repeatered lines, it offers improved performance, reduced cost and increased operating flexibility. Circuit concepts, new to short-haul carrier, are employed to make possible a preciseness of operation usually associated with high-density long-range systems.

Over-all quality is ensured by the use of the latest manufacturing techniques. Modern packaging concepts afford considerable savings and allow full flexibility of application.

Channel Equipment

- a. Two 12-channel groups
- b. Common Sideband Orientation
- c. Compatible with A5 Channel Bank
- d. Double channel regulation

CHAPTER 13 TYPE "N" CARRIER SYSTEMS

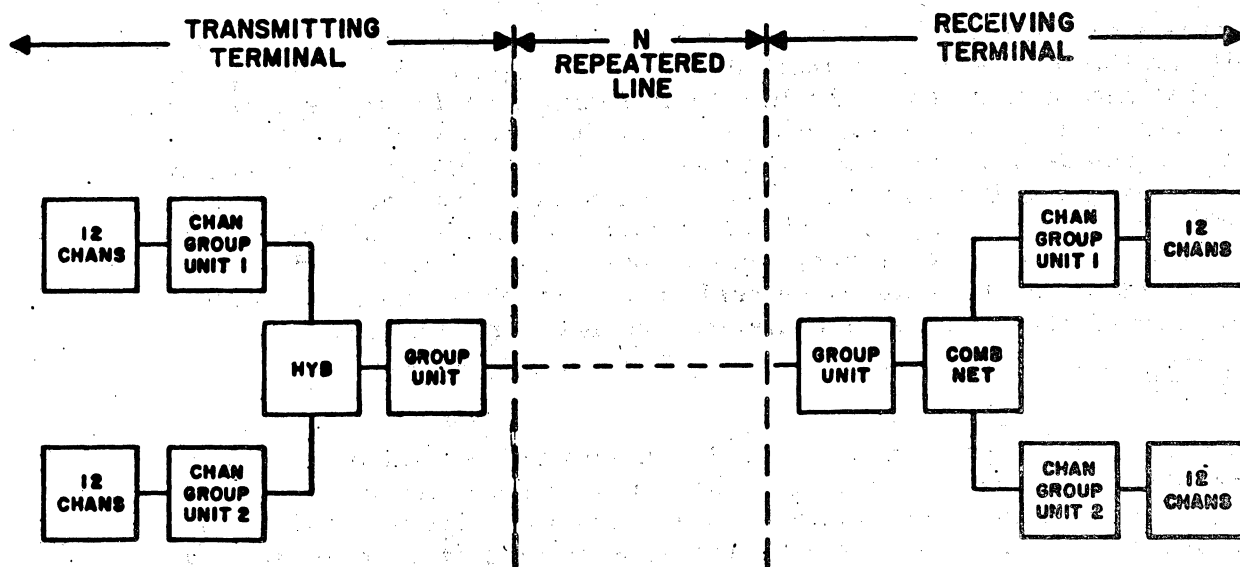

Fig. 13-6 N3 Carrier System Block Diagram

N3 Carrier uses the basic building block of a 12-channel group. The voice signals are compressed, modulated, filtered and combined in the transmitting channel equipment. All channels use upper sideband orientation. Alternate channel carrier frequencies (even harmonics) are transmitted at the proper level to prevent crosstalk interference with other types of carriers operating in the same cable.

The reverse process takes place in the receiving channel equipment. The channels are filtered, demodulated and expanded in order to retrieve the voice frequency. Regulation is achieved on an adjacent channel basis, controlled by the transmitted carriers. The transmitted carriers are also used to demodulate the even numbered channels. Non-transmitted carriers are obtained from a common supply to demodulate the odd numbered channels.

Channel Group Equipment

- a. Correction of Line Frequency Deviation
- b. Compatible with broadband data signal

The 12-channel signal together with the 6 transmitted carriers are received from the channel combining network and remodulated in the channel group equipment. The two 12-channel groups are then combined into a broadband 24-channel signal.

CHAPTER 13 TYPE "N" CARRIER SYSTEMS

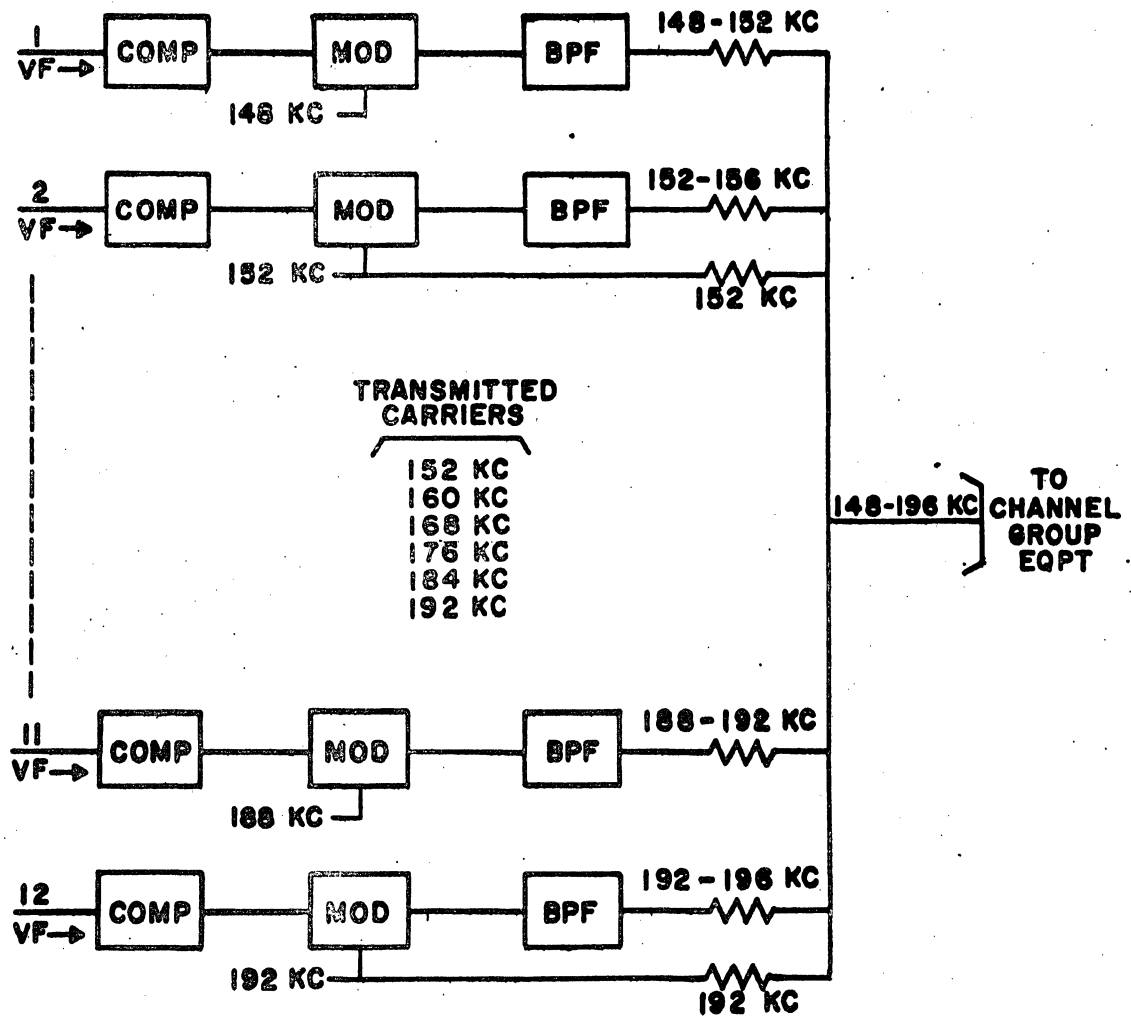

Fig. 13-7 N3 Channel Equipment - Transmitting

CHAPTER 13 TYPE "N" CARRIER SYSTEMS

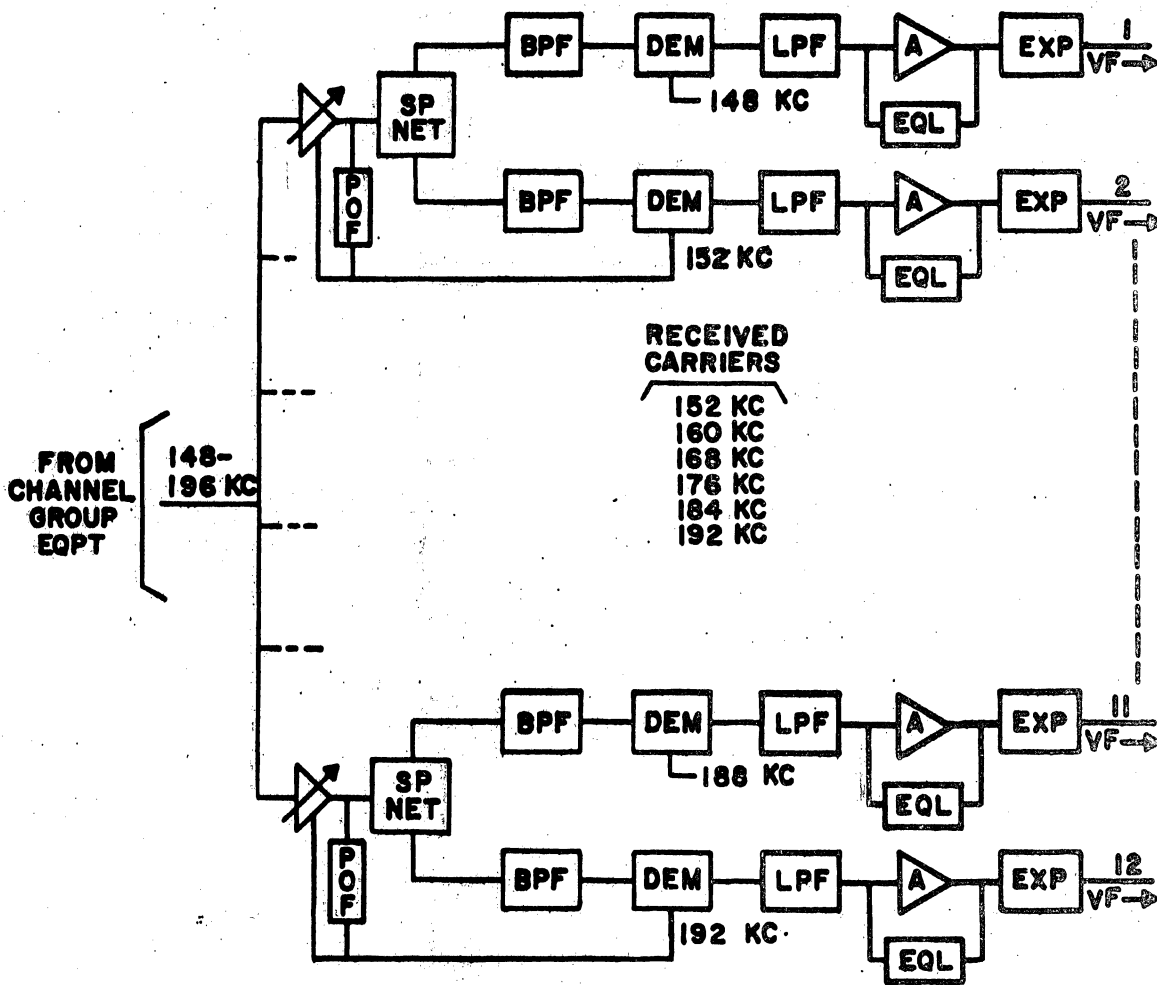

Fig. 13-8 N3 Channel Equipment - Receiving

CHAPTER 13 TYPE "N" CARRIER SYSTEMS

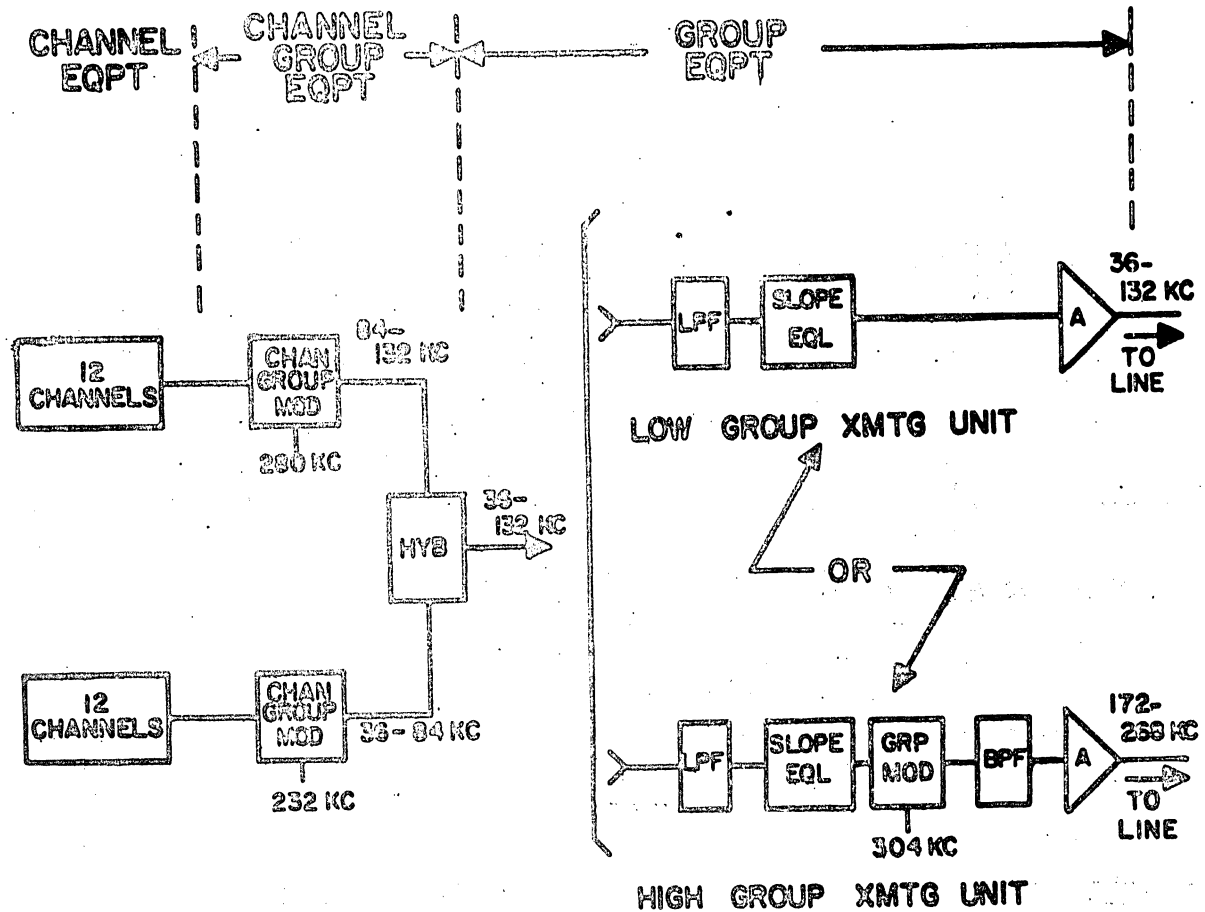

Fig. 13-9 N3 Transmitting Terminal

In the receiving leg, the demodulator is preceded and followed by band pass filters for proper channel group selection and image rejection. A three-stage amplifier provides the necessary signal gain before it is delivered to the double-channel regulators.

Frequency Correction Circuit

- a. Stabilizes Voice Frequency Equalization
- b. Permits use of Centralized Carrier Supply

CHAPTER 13 TYPE "N" CARRIER SYSTEMS

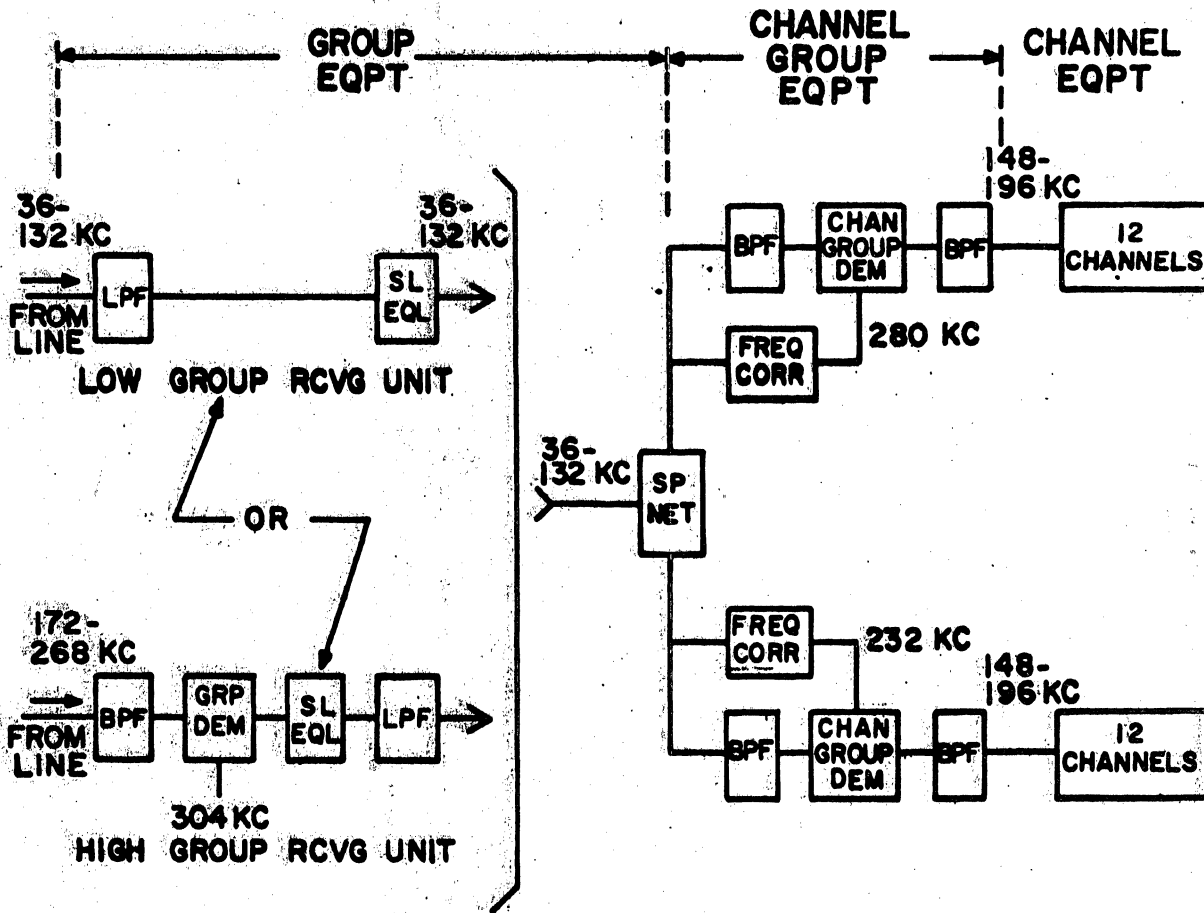

Fig. 13-10 N3 Receiving Terminal

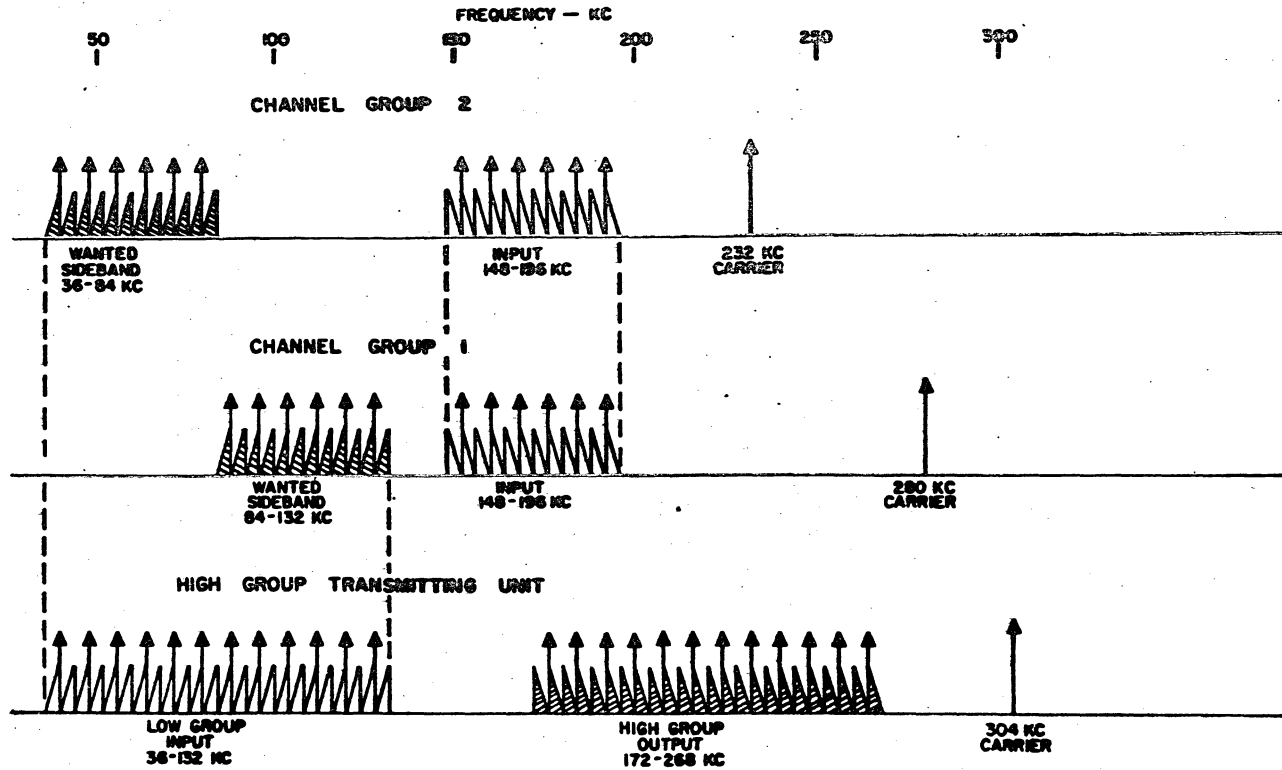

Fig. 13-11 N3 Modulation Plan

CHAPTER 13 TYPE "N" CARRIER SYSTEMS

A frequency correction circuit to correct for line frequency deviations is associated with each channel group demodulator. One of the transmitted carrier frequencies already affected by a line frequency shift, is selected by a pick-off filter. The received carrier is amplified and modulated with a carrier frequency from the local supply.

The frequency control modulator output, which retains the frequency shift error, is then fed into the channel group demodulator. Since the demodulating frequency and incoming signal contain the same error, the frequency deviation is eliminated.

This frequency shift correction prevents the degradation of voice frequency equalization, especially in type A program transmission. It also permits use of the centralized carrier supply for demodulation of channels that do not have transmitted carriers. Here savings are realized in terminal equipment which would be required to derive missing carrier frequencies.

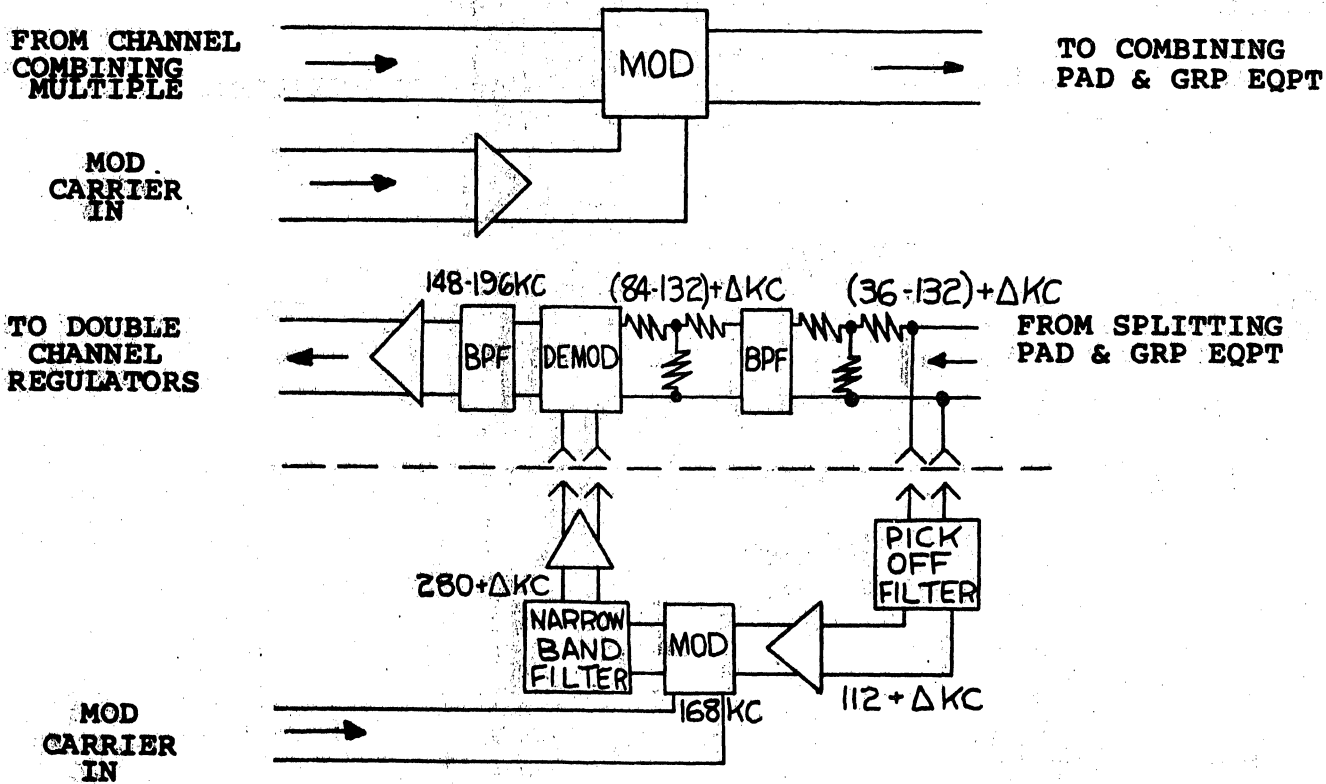

Fig. 13-12 Channel Group Modem and Frequency Control

CHAPTER 13 TYPE "N" CARRIER SYSTEMS

Group Equipment

- a. Direct connection to any N Carrier Line
- b. In-Service Switching

N3 Carrier group equipment is similar to that used in N2. This eliminates the need for carrier line frequency preparation by external frequency-frogging repeaters at the terminal points. High-group and low-group transmit and receive units are available for application to any established N Carrier line frequency plan.

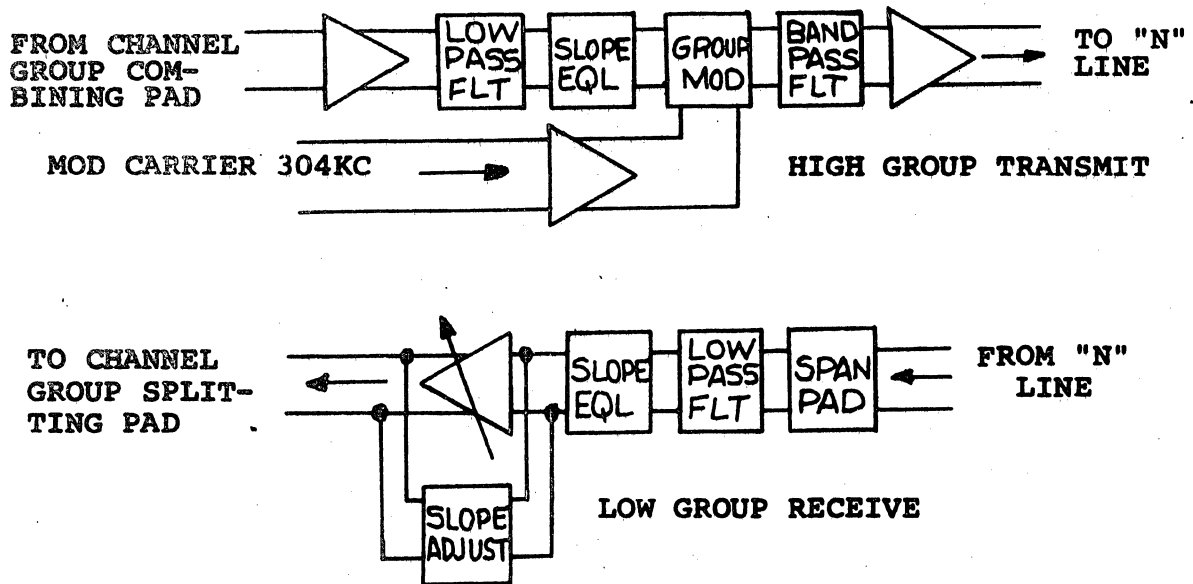

Fig. 13-13 Group Equipment

Repeatered Line

- a. Any N Line may be used
- b. Cross-talk eliminated
- c. Tandem Repeater Power Feed

N3 Carrier is designed to use the same cables with N1, N2, ON1 and ON2 Carrier. The even harmonic N3 channel carriers are applied to the line at the proper level to preclude any cross-talk with other systems operating in the same cables.

CHAPTER 13 TYPE "N" CARRIER SYSTEMS

N1 electron tube or transistor-operated repeaters or N2 repeaters, when available, may be used with the N3 system. Built-up distribution equipment enables the N3 terminal to furnish power to one N1 electron tube or 3 tandem N1 or N2 transistorized line repeaters.

Common Carrier Supply

- a. Economical
- b. Stable
- c. Reliable

The N3 Carrier system uses a common carrier supply rather than a locally generated one. The benefits thereby realized are not only economic but also operational. The achieved stability results in significant performance improvements in operation over N repeatered lines and makes possible special applications where highly accurate carrier frequencies are essential such as the N3 to L conversion.

The N3 Carrier supply is derived from an 8 kc oscillator operating into a binary divider for stability for a 4 kc tap of a J, K or L primary supply when available. The following 16 carrier frequencies are provided for the simultaneous operation of 26 N3 terminals:

- 12 channel carriers
- 2 channel group carriers
- 1 group carrier
- 1 frequency-translation carrier for N3 to L connectors

The primary supply will drive a harmonic generator where outputs are selected by crystal filters, amplified, filtered again and delivered to the primary distribution circuits. These frequencies are then connected to the secondary distribution circuits located in the carrier terminal bays.

Odd harmonics drive channel modulators and demodulators. Even harmonics supply channel modulators in addition to over-the-line frequencies used for regulation and demodulation purposes at the receiving terminal.

Carrier supply reliability is assured by duplicate power supplies, 4 kc supplies and carrier frequency amplifiers, all of which are arranged to switch automatically and give alarm indications.

CHAPTER 13 TYPE "N" CARRIER SYSTEMS

Carrier Supply Performance Characteristics

1. Frequency precise to ± 8 parts per million
2. Adjacent carriers down 60 db
3. Harmonics down 60 db
4. Output levels constant to within ± 0.5 db
5. Selected carriers (even harmonics) constant within ± 0.05 db

Compatibility with A-Type Channel Bank

- a. Economical System Extension
- b. Single Step Modulation
- c. Flexibility of Application

All N3 channels use upper sideband orientation in contrast with the upper and lower sideband transmission of the ON twin-channel approach. The common orientation of N3 sidebands improves the channel cross-talk by 10 db.

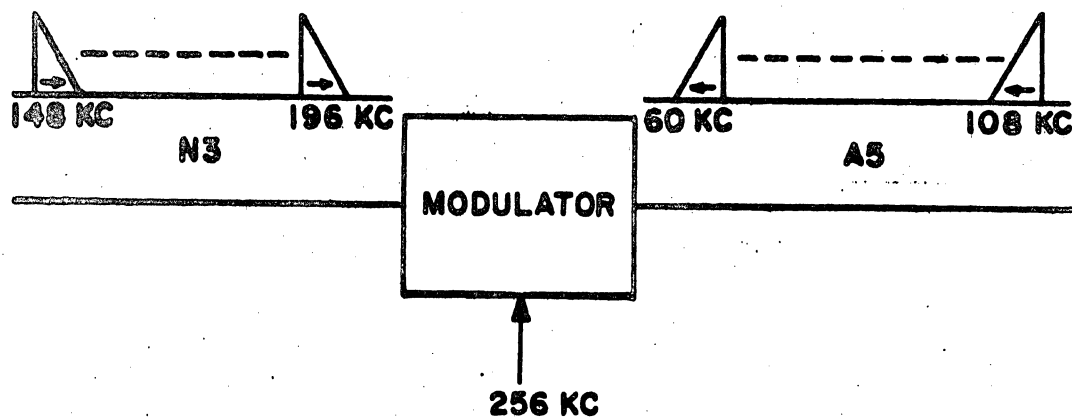

Fig. 13-14 Frequency Compatibility of N3 and A5

Common sideband orientation also allows the single-step modulation of N3 channel group frequencies to the spectrum of the A-type channel bank used in K and J Carrier and L Multiplex. This compatibility makes possible the low-cost extension of L Multiplex along secondary routes.

CHAPTER 13 TYPE "N" CARRIER SYSTEMS

Economies are realized by eliminating channel equipment associated with both systems and connecting them together at group frequencies instead of voice.

Equipment arrangements for two different applications of N3 to L connectors are available. The type A junction is used when transmission is to and from an N repeatered line with the N3 terminal remote from the L Multiplex office. The type B junction is applied when an N3 terminal is used at the L Multiplex office because there is an N repeatered link.

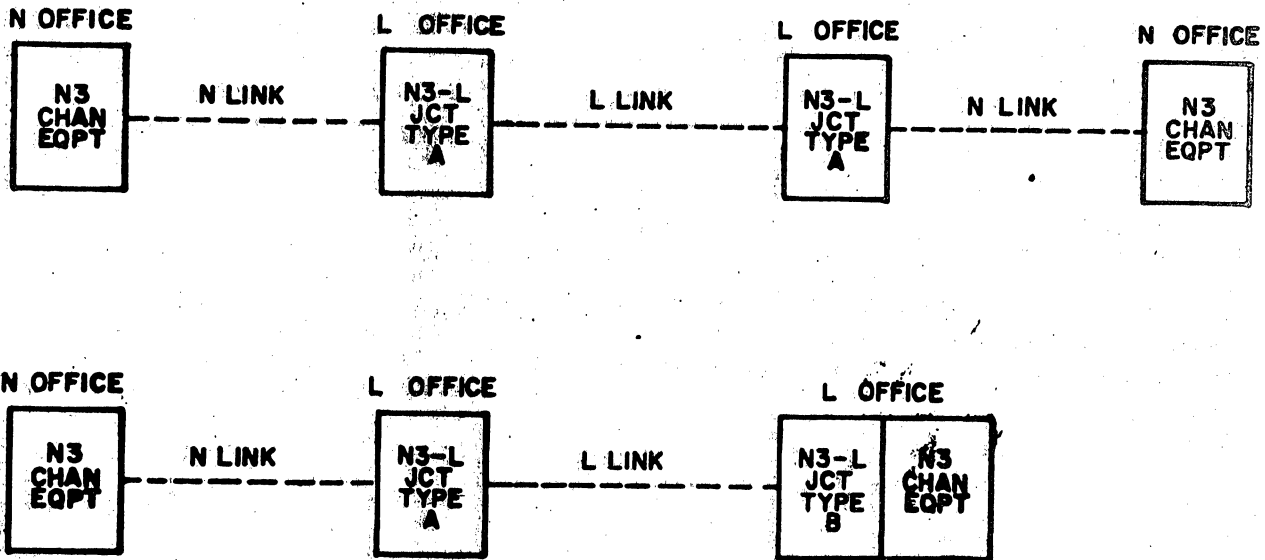

Fig. 13-15 Type A and Type B N3-L Junctions

CHAPTER 14

TYPE "O" CARRIER SYSTEMS

14.1 INTRODUCTION

The O carrier systems were developed to meet the need for an economical, short haul, open wire carrier system.

Studies indicate that 90% of our toll message circuits are in the "below 150 miles long" class.

Tremendous expansion program, at this time, presents difficult problem of obtaining the large number of circuits required in this class on an economical basis.

Stringing enough open wire appeared extremely difficult. The previously available open wire carriers are:

M - Six channels with limitation - 30 miles or less.

H - Single channel only.

C - Three channels, good for any distance, but too expensive for short haul.

J - Twelve channels, but too expensive for short haul.

The N1 carrier has just been developed for use in cable circuits. It is multi-channel, economical on short hauls, and compact. It appeared desirable to produce a new carrier for open wire employing many of the new developments used in the N1 system.

The basic requirements and desired features for the proposed system were established, and a new system known as "O" type was developed and is now being furnished.

The O type consists of four systems designated OA, OB, OC and OD. Each system has four channels. The OA system may be operated as either a 3 or 4-channel system.

The Type-O carrier system is designed to provide relatively short-haul carrier channels over open wire conductors on an economic basis. It makes use of ministurized equipment and many of the other features of the Type-N system including compandors, frequency-frogging and built-in 3700-cycle signaling.

The "O" carrier system operates on a two wire basis over an open wire pair, suitably transposed for such carrier transmission. The use of type "O" carrier is economically feasible for distances as short as 15 or 20 miles and can give satisfactory transrnission for distances of at least 150 miles. The maximum distance that can be covered depends a great deal

CHAPTER 14 TYPE "O" CARRIER SYSTEMS

upon the atmospheric conditions to be encountered. As in all open wire systems, wet weather, snow, sleet, ice and dust storms have a great effect upon the transmission characteristics of the "O" carrier. Any system must be planned with this in mind.

"O" carrier provides a maximum of 16 voice channels "stacked" from 4 sub-systems designated OA, OB, OC and OD. Each sub-system provides 4 channels in frequency ranges as follows:

OA 2 - 36 kc
OB 40 - 76 kc
OC 80 - 116 kc
OD 120 - 156 kc
OA low group 2.3 to 17.7 kc
OA high group 20.3 to 35.7 kc
OB low group 40.3 to 55.7 kc
OB high group 60.3 to 75.7 kc
OC low group 80.3 to 95.7 kc
OC high group 100.3 to 115.7 kc
OD low group 120.3 to 135.7 kc
OD high group 140.3 to 155.7 kc

Refer to Figure 14-1.

Separate frequency bands are used for each direction of transmission. An advantage of the method employing sub-systems lies in the fact that any sub-system may be used without the others. This permits the use of as few channels as required without expensive basic equipment. It also permits dropping off a sub-system along the line. For example the OB system which uses the frequency band from 40 to 56 kc for transmission in one direction, and the band from 60 to 76 kc for transmission in the opposite direction. As in the N-system, terminals are arranged to transmit either the low or high group of frequencies, and to receive the corresponding opposites. Repeaters, which are spaced at intervals of 40 to 50 db, are arranged alternately for low-high or high-low transmission. Unlike the N-system, however, single side-band transmission is used, with the upper and lower side-bands of a single carrier providing two channels transmitting in the same direction. Thus only two carriers, spaced 8 kc apart, are required to obtain the 4 voice channels. Figure 14-2 indicates the frequency transmissions employed in the terminal channel and group modulators, and at the repeaters of the OB system. The two carriers are transmitted over the line, and their combined power is used for regulation of the amplifiers at repeater and group receiving terminals to correct for line attenuation variations. Regulation is accomplished by means of a type of automatic volume control in which a part of the output of a line amplifier following the modulator is picked off and amplified in a "control amplifier", rectified and fed back to the input of a regulating amplifier that precedes the

CHAPTER 14 TYPE "O" CARRIER SYSTEMS

SYSTEM	REP MOD CARRIER	LG MOD CARRIER	HG MOD CARRIER
OA	NONE	198KC	216KC
OB	116KC	236KC	256KC
OC	196KC	276KC	296KC
OD	276KC	316KC	336KC

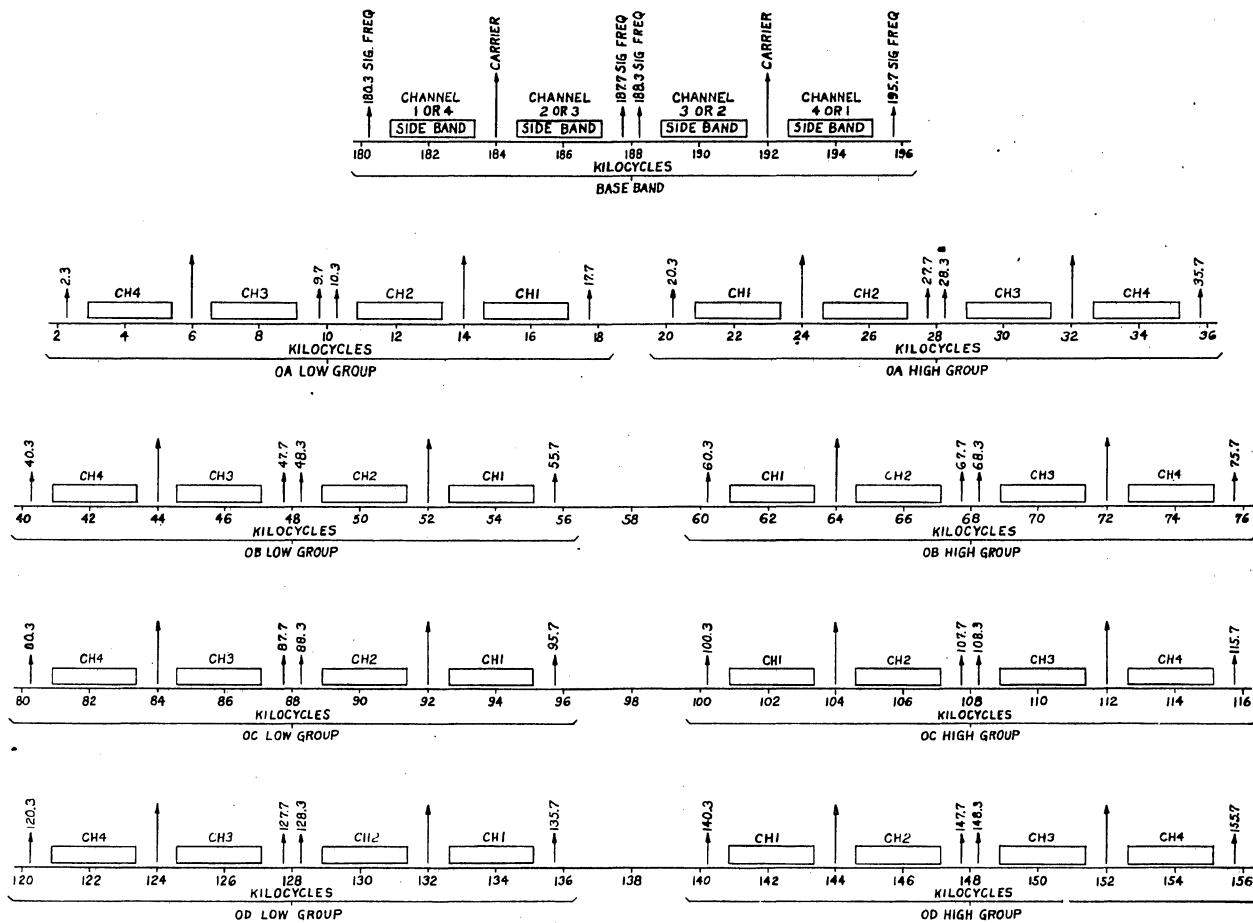

Figure 14-1 - Frequency Allocations for O Carrier Systems

CHAPTER 14 TYPE "O" CARRIER SYSTEMS

modulator. A block schematic of the arrangement of a repeater is given in Figure 14-3. Other units employed in the O-system are practically identical with their counterparts in the N-system, which have already been discussed. The two channels common to a single carrier are known as twin channel.

14.2 OVERALL SYSTEM

Each type O carrier system provides four 2-way telephone channels over an open-wire pair suitably arranged for such carrier transmission. The application of all four systems to a suitably transposed open-wire pair will provide sixteen 2-way channels. Photographs of an OB1 terminal and repeaters are shown in Figs. 14-4 and 14-5. The appearance of the OC1 and OD1 equipment is identical. The OA1 is generally similar. The line frequencies employed by the O systems extend from 2 to 156 kilocycles, and are assigned as shown in Fig. 14-1. Each of the O systems uses two adjacent 16-kc bands, one band called the low group and used for one direction of transmission, and one called the high group and used for the other direction of transmission.

Single sideband transmission is used, with the upper and lower sidebands of a single carrier providing two channels transmitted in the same direction. Two carriers spaced 8 kc apart are transmitted at reduced level and their combined power is used to control the flat gain regulation at repeaters and terminals, correcting for transmission changes due to weather conditions.

The terminals are arranged to transmit either low- or high-group frequencies. A low-group transmitting terminal (LGT) transmits the low group and receives the high group. Conversely, a high-group transmitting terminal (HGT) transmits the high group and receives the low group.

In the case of the OB, OC, and OD systems, frequency-frogging repeaters interchange and invert low- and high-group frequency bands. The repeaters are arranged to transmit either low- or high-frequency bands alternately. The low-high (L-H) repeater receives at its input the low group of frequencies which are converted to the high group before amplification. The high-low (H-L) repeater does the opposite. OA repeaters do not make use of frequency frogging; therefore each repeater consists of a low-group repeater amplifier and a high-group repeater amplifier.

A compandor is included in each channel. Compandors greatly reduce cross-talk and noise and their use results in more lenient requirements for filters and line treatment (transpositions, etc.).

Signaling arrangements (out-of-band) are built into the terminals for transmission of ringdown and supervisory signals and dial pulses over the system. Other types of signaling may be employed as discussed later. Terminal alarm arrangements provide an automatic disconnect and busy

CHAPTER 14 TYPE "O" CARRIER SYSTEMS

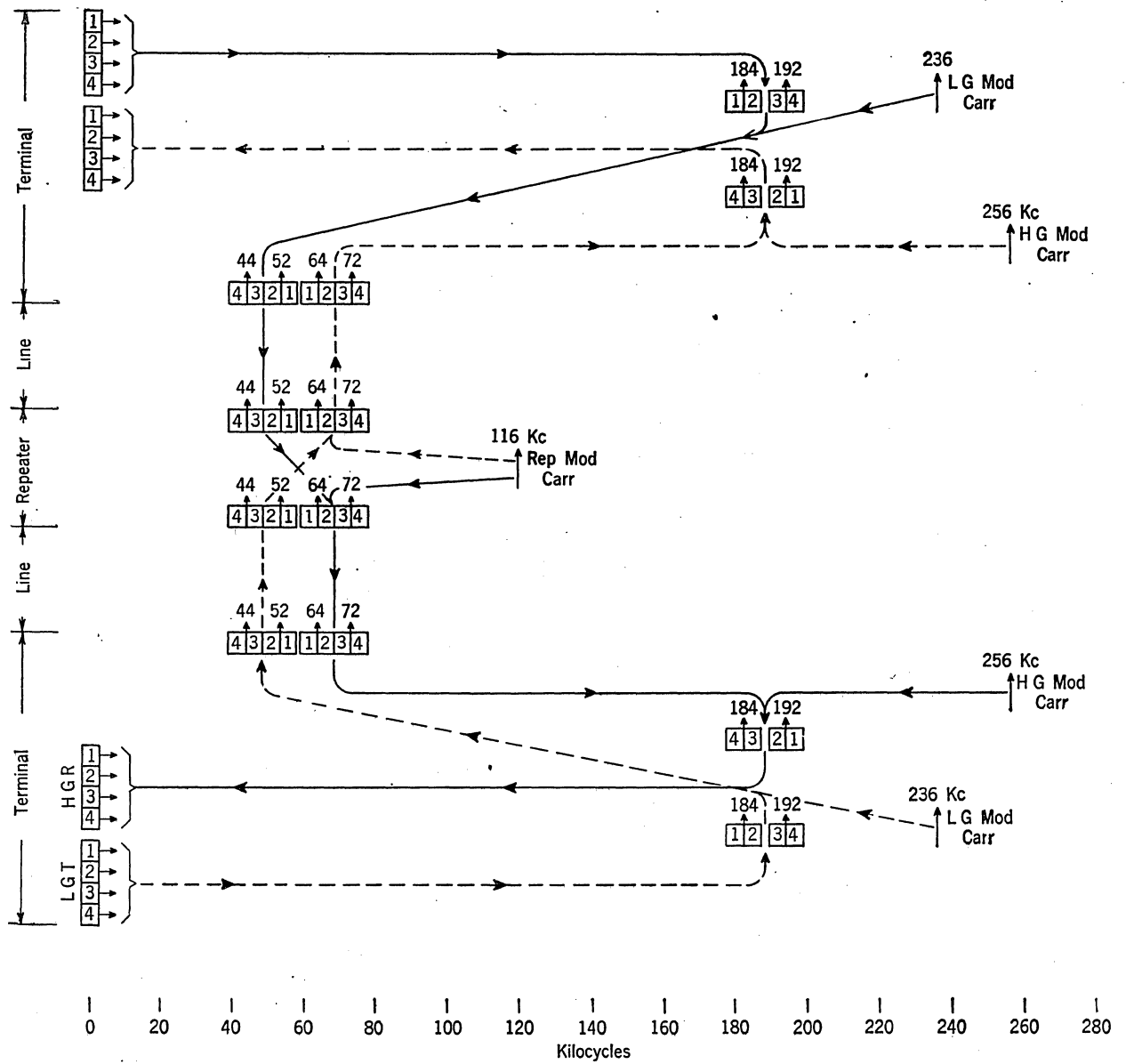

Figure 14-2

Type OB1 Carrier Frequency Translations

CHAPTER 14 TYPE "O" CARRIER SYSTEMS

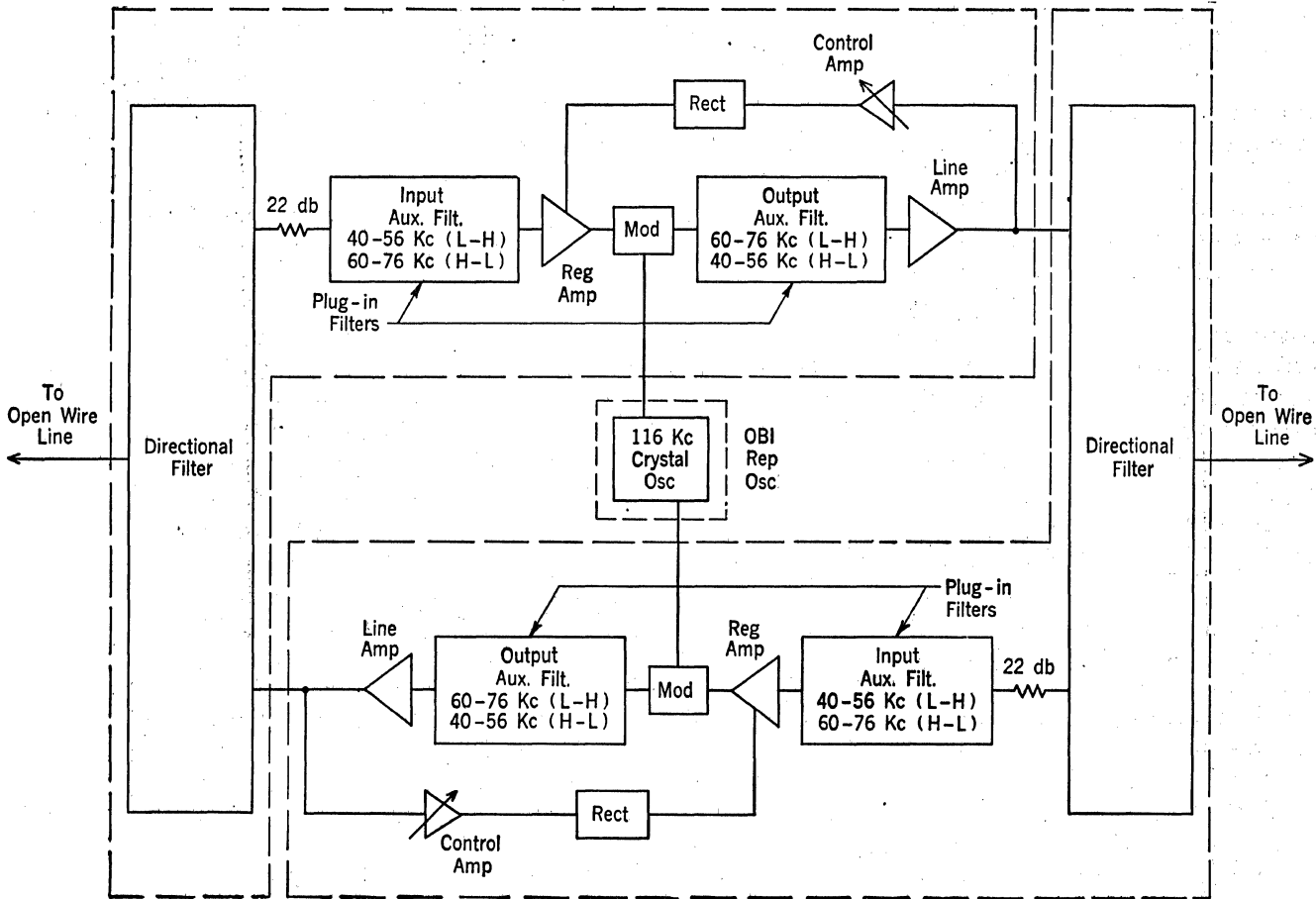

Figure 14-3

Block Schematic of Type OBI Repeater

CHAPTER 14 TYPE "O" CARRIER SYSTEMS

signal on all E leads in case of system failure (failure of received carriers). Means are provided for making a loop transmission check of the system from either terminal. Restoration of the system to normal service may be done from either terminal or from any other point. Also fuse and signaling oscillator supply-failure alarms are provided. At all repeaters fuse-failure alarms are provided. Additional alarm features are available at pole-mounted repeaters.

No order-wire facilities peculiar to the type O system are being provided. Existing order-wire arrangements will be employed.

Terminals require -48 and +130 volt regulated power supplies. Repeaters use either a +130 volt supply alone, or, where it is available, a -48 volt supply in addition.

Miniature components are used throughout, compactly assembled in aluminum die-cast chassis. Units so formed are plugged into jacks associated with the mounting, providing both flexibility and ease of maintenance. Changing from one type of operation to another (high-or low-group transmitting at terminals, OA low-group or high-group repeater amplifiers, or OB, OC, or OD low-high or high-low repeaters) or from one type O system to another (OB system to OD system, for example) is readily accomplished by means of plug-in filters and equipment units.

System line-up and maintenance are facilitated by the provision of test points appearing on the front faces of terminal and repeater equipment units for use in bridging measurements. Adjustment of repeater and terminal group equipment is done with the units in service. Adjustment of the channel and twin-channel units is done on an out-of-service basis by removing them from the terminal mounting and operating them in a test stand through a connecting test cord. The plug-in feature of the units facilitates maintenance and permits easy replacement of units for servicing. The further breakdown of the channel unit into three plug-in subassemblies permits ready access to the components, quick localization of trouble by substitution and materially reduces the requirements for spare equipment.

The unit method of construction has been followed in designing the equipment of the O carrier system. Die-cast aluminum alloy frameworks for terminal and repeater mountings, units and unit subassemblies are used throughout. The external connections of each unit terminate in a plug while engages a jack in the terminal or repeater mounting. This method permits the testing of the units without jack fields and allows the removal of any unit in trouble to a convenient location for maintenance and its replacement by a spare unit. It makes efficient use of the full depth (10 inches) of available relay rack space. Access for maintenance is required only on the front. Either terminals or repeaters can be mounted back-to-back or against a wall. All equipment is designed for 19-inch wide duct, channel, or bulb-angle type bays.

CHAPTER 14 TYPE "O" CARRIER SYSTEMS

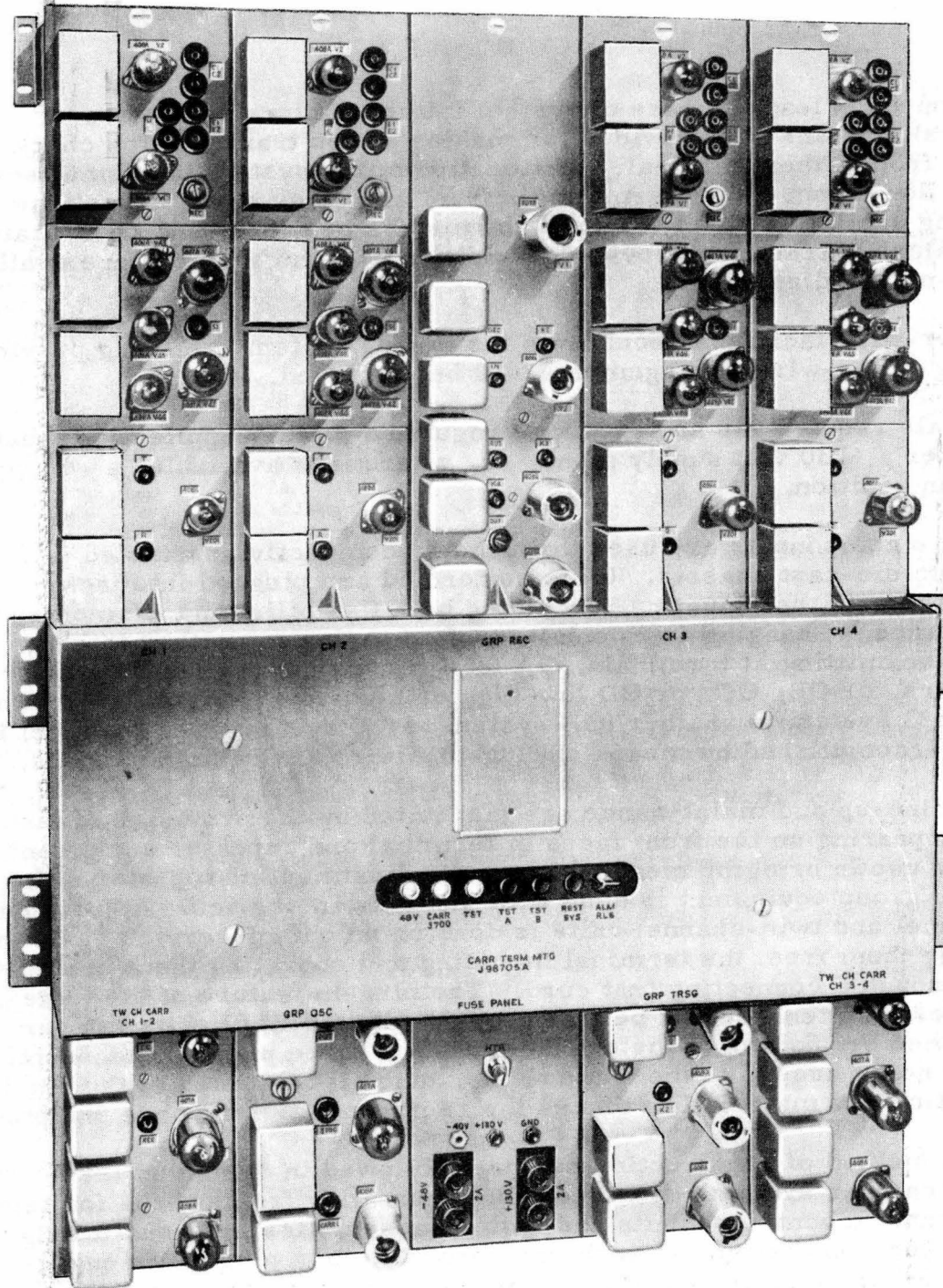

Fig. 14-4 - OB1, OC1, or OD1 Carrier Terminal

CHAPTER 14 TYPE "O" CARRIER SYSTEMS

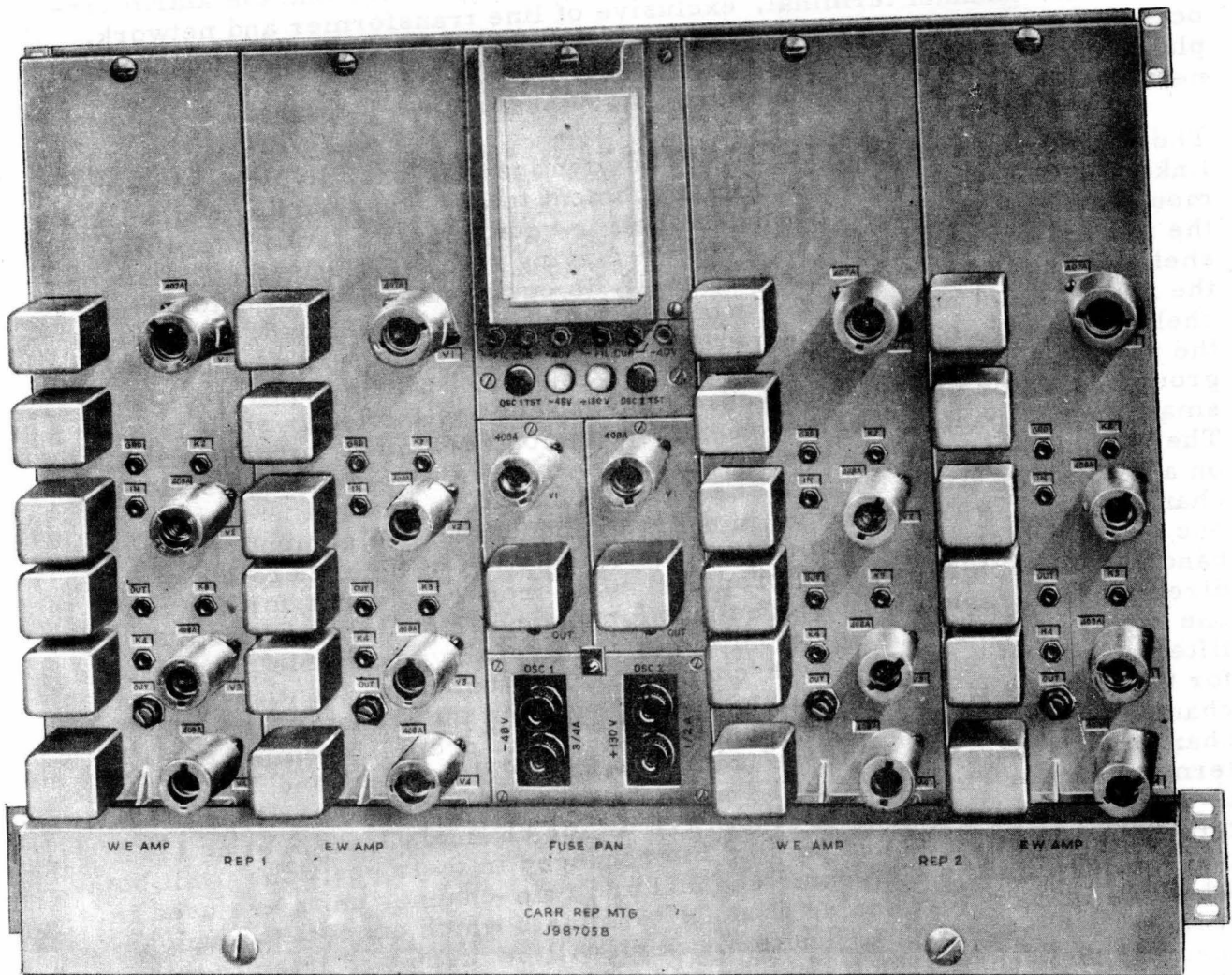

Fig. 14-5

Two OB1, OC1, or OD1 Carrier Repeaters (with fabricated fuse panel)

CHAPTER 14 TYPE "O" CARRIER SYSTEMS

A complete terminal, as shown in Fig. 14-4, includes four channel units, two twin-channel carrier units, a group oscillator unit, a group transmitting unit, and a group receiving unit plugged into jacks in the terminal mounting. This mounting is secured to the bay and contains jacks, terminal strips, and interconnecting wiring, power supply fuses, and the alarm circuits. A 4-channel terminal, exclusive of line transformer and network, occupies a vertical bay space of 24-1/2 inches (14, 1-3/4-inch mounting plate spaces). Four complete terminals, including line transformer and network panels, can be mounted in an 11-foot, 6-inch bay.

The terminal mounting consists of two identical die-cast aluminum shelves linked together and arranged for attachment to any standard bay which will mount 19-inch panels. The upper shelf is equipped with jacks into which the four channel units and the group receiving unit are plugged. The lower shelf, which is an inverted upper shelf, is equipped with jacks into which the four channel units and the group receiving unit are plugged. The lower shelf, which is an inverted upper shelf, is equipped with jacks into which the two twin-channel carrier units, the group transmitting unit, and the group oscillator unit are plugged. Also attached to the lower shelf is a small plug-in panel with the power distribution equipment for one terminal. The relays, keys, and lamps associated with the alarm circuits are located on a removable panel between the two shelves. The channel units for channels 1 and 4 are identical in every respect, and assignment of a unit to one of the two channels determines the orientation of the reversible plug-in band filter which selects the proper channel frequency bands for the two directions of transmission. The unit for channel 2 or 3 differs from the one for use on channel 1 or 4 only in the code of the reversible plug-in band filter employed. The two twin-channel carrier units are identical except for the frequency of the oscillator which supplies the transmitting twin-channel carrier and the filter which picks off the proper incoming twin-channel carrier. One of these units is used for channels 1 and 2 at an HGT terminal or for channels 3 and 4 at an LGT terminal; the other type of unit is used for channels 3 and 4 at an HGT or for channels 1 and 2 at an LGT terminal. Thus they need only be interchanged in their positions to fit both types of terminals. The same channel and twin-channel units are used in all of the type O1 terminals. For O1 terminals which connect through an open-wire pair to an ON1 junction, which will be discussed later in this chapter, twin-channel units having wider band pick-off filters are required; otherwise they are identical.

The group transmitting unit, the group oscillator unit, and the receiving modulator-amplifier unit (group receiving unit, less plug-in filters) are the same for both high-group and low-group transmitting terminals of a particular O system. A double section filter and a reversible directional filter are plugged into sockets on the modulator-amplifier chassis to complete a group receiving unit. The code of the former filter and the orientation of the latter are determined by the type of terminal (LGT or HGT) in which the unit is to be used. The proper group carriers from the group oscillator

CHAPTER 14 TYPE "O" CARRIER SYSTEMS

unit are supplied in accordance with the type of terminal (HGT or LGT) by strapping the correct terminals on a terminal block in the group oscillator unit. For OAl terminals, straps on an inductor in the group transmitting unit and a terminal block in the group receiving unit are also changed according to their use in an HGT or LGT terminal. The group transmitting unit and the receiving amplifier-modulator unit are the same for OB1, OC1, and OD1 terminals, different plug-in filters being required for the receiving amplifier-modulator unit to make the proper group receiving unit for a particular terminal. The group transmitting and receiving amplifier-modulator units for OAl terminals are different from those of the OB1, OC1, and OD1 terminals, although their external appearances are similar. The group oscillator unit for each system is different in that different group carriers must be supplied for each type of terminal (OAl, OB1, OC1, or OD1); their external appearances are identical.

Construction of the repeater equipment is similar to that of the terminal. The mounting, accommodates two complete repeaters, each consisting of three plug-in units (two one-way repeater amplifiers and an oscillator or dummy oscillator). As in the terminal, power fuses and fuse alarm circuits are furnished as part of the mounting. A 2-repeater installation, exclusive of line net works, occupies a vertical bay space of 14 inches (8, 1-3/4-inch mounting plate spaces). Twelve repeaters mount on an 11-foot, 6-inch bay. Four repeaters, together with an ac power supply and other auxiliary equipment, can be housed in one cabinet approximately 2 feet wide, 15 inches deep, and 6 feet high arranged for pole mounting.

For the OB, OC, and OD systems, the repeater amplifier unit is identical to the group receiving unit used in the terminal except for the plug-in auxiliary band filter. The orientation of the plug-in directional filter and auxiliary band filter, both of which are reversible, determines whether the unit is an LH or an HL repeater amplifier. Different filters are used according to whether the unit is to be used in an OB1, OC1, or OD1 repeater. Because the OAl repeater does not frequency frog and because of the lower frequencies involved, the final amplifier in the OAl repeater is different from that of the OAl group receiving unit. The conversion between low-group and high-group OAl repeater amplifier is accomplished by reversing the directional filter, changing the auxiliary filter, and changing the strapping on a terminal block.

14.3 OPERATION OF THE "O" CARRIER SYSTEM

The over-all system functions as follows. The voice frequencies enter the channel circuits from the associated office trunk circuit. Where the office conditions permit, the voice frequencies pass through a resistance hybrid. In offices where external hybrids are used or in 4 wire switching offices, the resistance hybrid is not used. The message is then passed through a compressor, amplifier and 3100 cycle low pass filter. The use of the

CHAPTER 14 TYPE "O" CARRIER SYSTEMS

compressor greatly reduces the crosstalk and noise, resulting in more lenient requirements for filters and line treatment. From the low pass filter, the message is passed through a modulator where it modulates a 184 or 192 kc carrier provided from the crystal controlled oscillator in the twin channel circuits. Channel circuits are the same for all of the O carrier types. The use of the 184 or 192 kc carrier is determined as follows:

<u>CHAN. NO.</u>	<u>CARRIER FREQ.</u>		<u>SIDEBAND</u>	
	<u>LGT</u>	<u>HGT</u>	<u>LGT</u>	<u>HGT</u>
1	184 kc	192 kc	180 to 184 kc	192 to 196 kc
2	184 kc	192 kc	184 to 188 kc	188 to 192 kc
3	192 kc	184 kc	188 to 192 kc	184 to 188 kc
4	192 kc	184 kc	192 to 196 kc	180 to 184 kc

From the modulator the signal passes through a band pass filter which allows only a single side band (frequency shown above) to go on to the resistance type combining multiple and then to the group transmitting circuit.

(Refer to Figure 14-6 block Schematic for OB1 Carrier Terminal)

In the group circuits, the side band (along with the other 3 sidebands representing the 3 other channels of the group) is again modulated to bring the band up or down to the proper frequency for transmission on the open wire. The band of frequencies is then passed through a low pass filter to eliminate undesired signals. It is then amplified to the proper level for the line. After passing through a directional filter which separates the incoming and outgoing frequencies and eliminates the frequencies from the other types of O carrier on the line, the band of frequencies is combined with those of the OB, OC, or OD as required. The combined frequency bands then pass through the line transformer and test jacks to the office main frame. From here, they are carried on the entrance cable to a pole mounted filter where they are combined with OA carrier or voice frequencies and then go out over the open wire. In some instances this last filter may be located within the office. The filter arrangement must vary with the types of carrier (C, H etc.) which are using the pair or adjacent pairs.

If repeaters are used, the requirements vary with the types of O carrier. The higher the frequency band used, the greater the line losses and the shorter the repeater section permissible.

The repeater used in the OA carrier system performs three basic functions. It separates the two groups of frequencies used for the two directions of transmission on the open wire pair, amplifies the signals and transmits them to the line, and automatically regulates the gain to compensate for changes in line loss. OB, OC and OD repeaters perform an additional basic function. They translate and invert the incoming group by modulation

CHAPTER 14 TYPE "O" CARRIER SYSTEMS

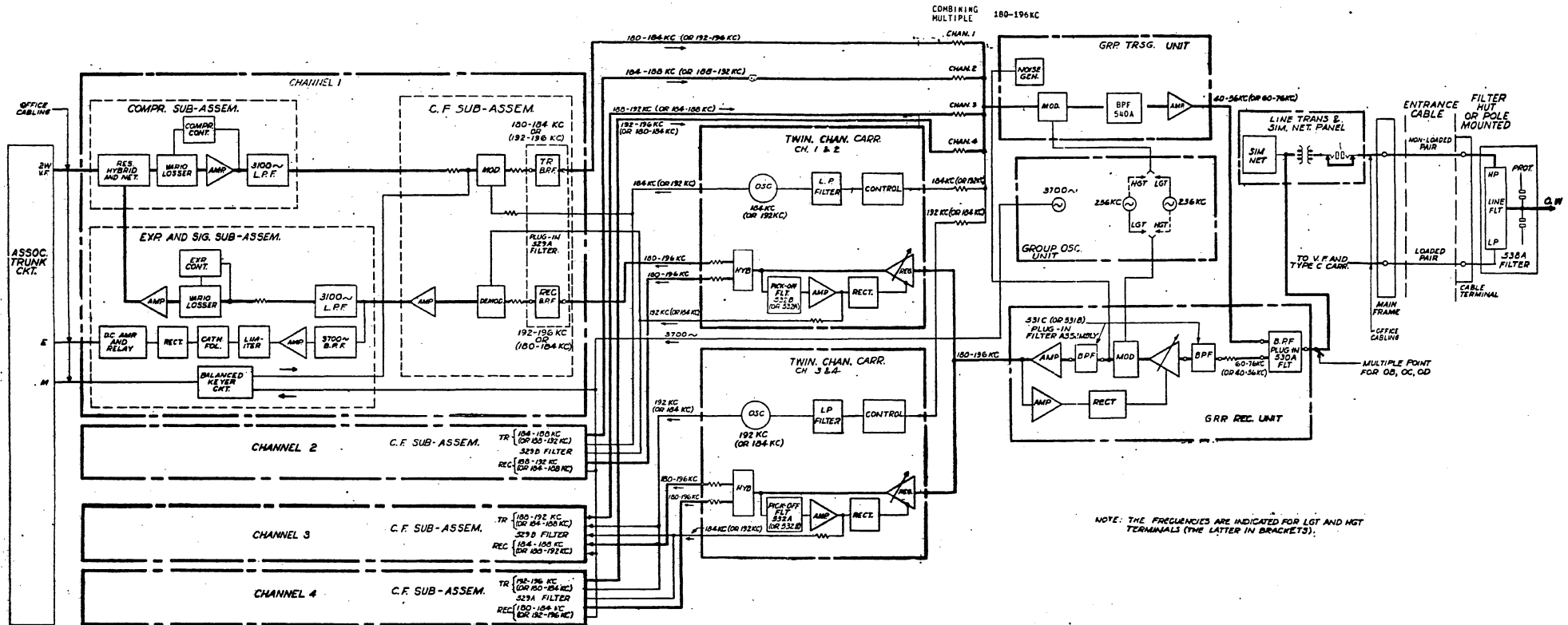

Fig. 14-6

TERMINAL - BLOCK SCHEMATIC
OBI CARRIER.

CHAPTER 14 TYPE "O" CARRIER SYSTEMS

to the opposite group. That is, they are frequency frogging repeaters. At the receiving terminal, the band of frequencies passes through the pole mounted line filter, through the entrance cable and to the office main frame. From here, the frequency band passes through the line transformer to the group receiving circuits. Here it passes through a directional filter which allows only those receiving frequencies desired to pass. (2 carriers & 4 side bands) The low-level incoming line frequencies then pass through a band pass filter and a flat gain regulating amplifier. A double balanced type varistor modulator then converts the incoming frequency band from the line frequencies to the range of the channel band filters, 180 to 196 kc. This base frequency band is then passed through a band pass filter and amplified.

The base band less the input and modulating carrier frequencies is then passed to the 2 twin channel circuits.

Each twin channel circuit is arranged to handle a carrier with its two associated sidebands. While 2 carriers and 4 sidebands are present at the input of the receiving section of the twin channel circuits, each circuit is arranged to pick off only the carrier frequency for the two channels concerned. This carrier is the product of the line frequency carrier and the modulation carrier of the group circuits. This "picked off" frequency is then amplified & rectified and utilized to regulate the amplifier gain to hold that particular carrier and the associated two channels constant at the amplifier output. The carrier and channel frequencies, at this point are as follows:

<u>Chan. No.</u>	<u>HGR</u>		<u>LGR</u>	
	<u>Carrier</u>	<u>Sideband</u>	<u>Carrier</u>	<u>Sideband</u>
1	192 kc	192 to 196 kc	184 kc	180 to 184 kc
2	192 kc	188 to 192 kc	184 kc	184 to 188 kc
3	184 kc	184 to 188 kc	192 kc	188 to 192 kc
4	184 kc	180 to 184 kc	192 kc	192 to 196 kc

A hybrid in the output of the receiving portion of the twin channel unit then distributes the band of frequencies (4 chans.) to each of the 2 associated channel units.

In the channel circuits, a band pass filter eliminates all but the side band desired. This side band is then passed to a shunt type balanced varistor modulator. Here the message and signaling sidebands are demodulated to voice frequency against the carrier which has been selected by the pick off filter in the twin channel circuit, amplified, and fed to the demodulator over a pair of leads separate from those through which the side band energy has been fed.

CHAPTER 14 TYPE "O" CARRIER SYSTEMS

The voice frequencies are then fed through a 3100 cycle low pass filter, expander and amplifier. From here, they pass through a variable pad to adjust to the office level. The voice frequencies are then passed through the resistance hybrid and brought out to the office distributing frame for cross connection to trunks. On 4 wire voice circuits, the hybrid is not used.

The built in signaling system is essentially similar to that of the N-1 system.

14.4 MAJOR EQUIPMENT IN THE O SYSTEM

Two types of channel circuits are available. The more common one, known simply as a channel circuit, is used except where a channel is to be permanently connected in tandem with another O or N carrier channel. The other, known as a through channel unit, is used for such a through connection.

On the transmitting side the channel circuits modulate the four voice channels to the 180- to 196-kc range. On the receiving side the outputs of the channel filters, 180 to 196 kc, are demodulated down to voice. The channel circuits also provide compression and expansion of the voice signals and include the built-in signaling arrangements. The channel units are the same for all of the O systems. Channel units 1 to 4 are the same within any system except for the band filters. The latter are furnished as plug-in units of apparatus and only two codes are provided. Each code includes two filters of different frequency bands and four combinations are obtained by proper orientation of filters in the sockets. Two filters of each code are required at each O1 terminal.

Each channel unit is composed of three subassemblies connected by plugs and jacks to form the complete plug-in unit. These are identified as the compressor (containing the voice frequency transmitting section), expander-signaling (containing the voice frequency receiving section), and carrier frequency (containing the modulator, demodulator and channel band filter sections) subassemblies. The compressor-and expander-signaling subassemblies are alike for all four channels of all the O systems.

These units are very similar in function and theory of operation to the N carrier components discussed in the previous chapter.

Where an O carrier channel is to be connected permanently (by cross-connection) in tandem with a channel in another O system or an N system, a relatively simple through channel unit may be substituted for the channel unit previously described. This through channel unit consists of the usual carrier subassembly combined with a simplified through voice frequency subassembly in place of the compressor subassembly and expander and signaling sub-assembly. The through channel unit is plugged into the terminal mounting in place of the normal channel unit. Each through voice frequency subassembly provides level adjustment and amplification on the

CHAPTER 14 TYPE "O" CARRIER SYSTEMS

receiving side and impedance matching on the transmitting side. Separate level adjustments are provided for the message power and the 3700-cycle signaling power. By switches the unit may be conditioned for use in an N or O terminal and for connection to an N or O channel in another system.

Each twin-channel carrier circuit performs four functions. On the transmitting side it supplies the common carrier (184 or 192 kc) to the modulators of two channels; also the same carrier is supplied to the combining multiple for eventual transmission over the line. On the receiving side it selects the complementary incoming common carrier and amplifies it for supplying the associated demodulators and at the same time provides a nearly constant output level of the associated sideband thus supplementing the regulation of the group receiving circuit. These functions are carried out at the channel frequencies, 180 to 196 kc.

The group receiving circuit regulates the four incoming channels as a group. The control circuit is flat and the total power output is about +9 dbm. However, one carrier and consequently its two associated channels may be several db lower in level than the other carrier and its two associated channels because of slope of the line attenuation characteristic across the band. Because of changing weather conditions this difference between the two carriers changes. The twin-channel carrier circuits practically remove this changing difference by regulating each carrier and its associated pair of channels to an approximately constant output.

Reference to Fig. 14-6, the OBI terminal block schematic, shows that the two twin-channel carrier circuits are identical except for the frequencies of the oscillators and the frequencies of the carrier pick-off filters. To change a terminal from LGT to HGT it is only necessary to interchange the two twin-channel carrier units in the terminal mounting. The same kinds of twin-channel carrier units are used for all of the OI terminals. The received carriers at an OI terminal which connects through an open-wire line to an ON junction (described later in this chapter may have wider frequency variations due to the possible large number of frequency frogging points in an ON system. For this reason, type OI terminals which are associated with an ONI junction use twin-channel units which have wider band pick-off filters.

Two twin channel units are associated with one terminal. One is associated with channels 1 & 2, the other with channels 3 & 4. The transmitting side of the twin-channel unit figure 14-7 very briefly operates as follows:

- The carrier oscillator is a 408A pentode tube, crystal controlled.
- A potentiometer (TC) affords a means of adjustment of the transmitted carrier to the required value.

A pin jack (TC) provides a point for measurement of the carrier.

CHAPTER 14 TYPE "O" CARRIER SYSTEMS

The receiving side figure 14-8 operates as follows:

The receiving side of the twin channel unit consists of a variable gain amplifier and associated control circuit.

The variable gain amplifier is a 407A twin triode, using impedance interstage coupling.

A potentiometer (REG) is provided for gain adjustment purposes. Regulation is accomplished by use of a pick-off filter to select the carrier complementary to the pair of channels being served by the twin channel unit, amplifying and rectifying this frequency and using the resultant DC as AVC bias to control the gain of the variable gain amplifier.

This is fast acting AVC, being on the order of 100 times as fast in regulation as that used in the group receiving unit.

The group transmitting circuit performs three functions. It shifts the four sidebands and two carriers at the channel frequencies to the line frequencies to the line frequencies, amplifies them to obtain the proper line level (provision is made for lowering the output line level for coordination purposes or reduction of interaction crosstalk) and provides a noise generator, the output of which is introduced into the transmission path of the group receiving circuit for masking intelligible crosstalk.

This unit contains a noise generator that serves to mask crosstalk, the transmitting group modulator and band filter and a transmitting line amplifier. This unit is arranged for either high group or low group transmission.

The output of the combining multiple is applied to the group modulator, a schematic of which is shown in Fig. 14-9. It is the double-balanced-type consisting of a copper oxide varistor CR1 connected between transformer T1 and T2. A perfect balance is not achieved practically but the input signal is suppressed about 20 db and the carrier about 40 db. Transformer T1 has an impedance ratio of 135 ohms to 135 ohms while T2 has a step-up ratio of 135 ohms to 3000 ohms. Transformer T2 in the OAl group transmitting unit is different from the one in the OB1, OC1, OD1 unit since one transformer could not be used to cover the whole frequency range from 2 to 156 kc.

14.18

CARR. SUPPLY
FOR MODS. OF
C.F. SUB-ASSEMBLY
OF ASSOCIATED
CHANNEL UNITS

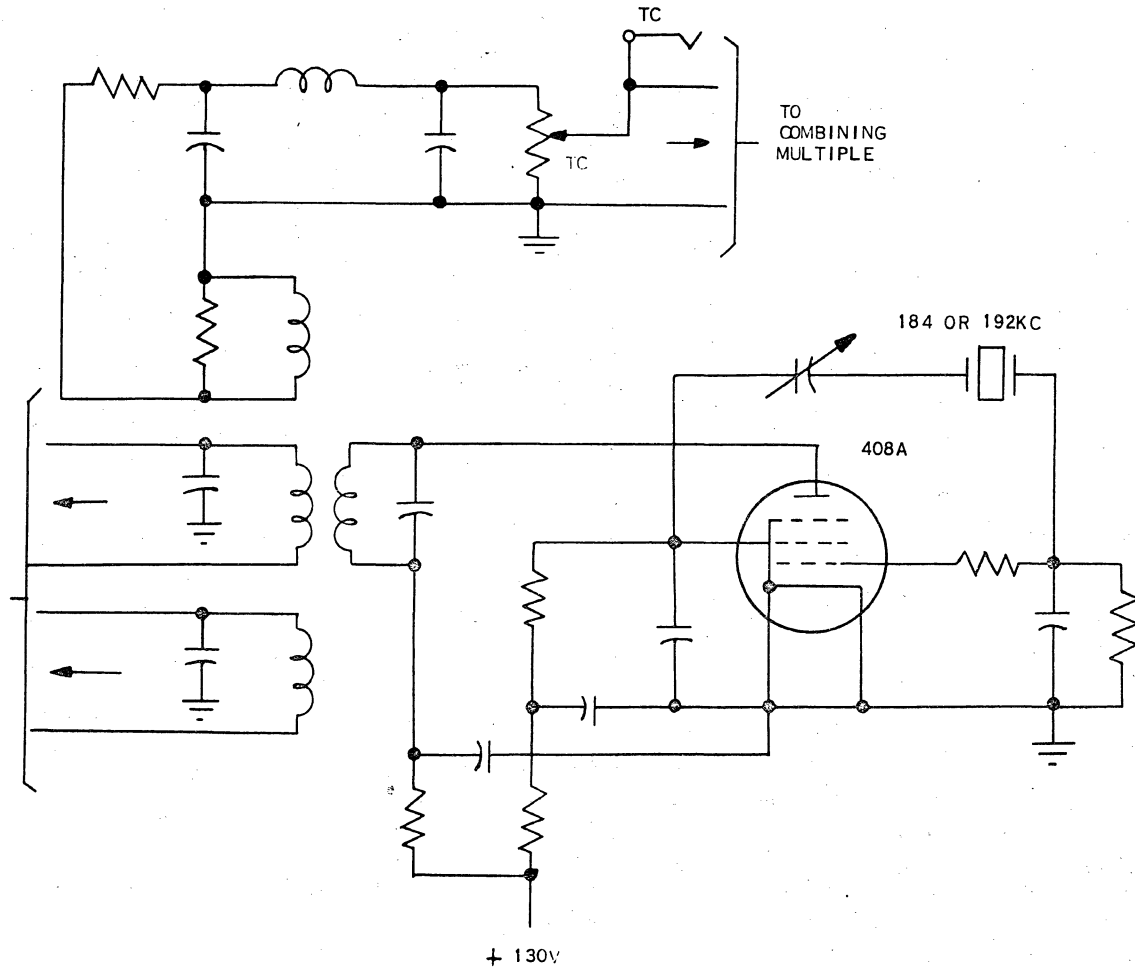

TRSG. SIDE OF TWIN CHANNEL CARRIER CKT.
OB1 CARRIER
Fig. 14-7

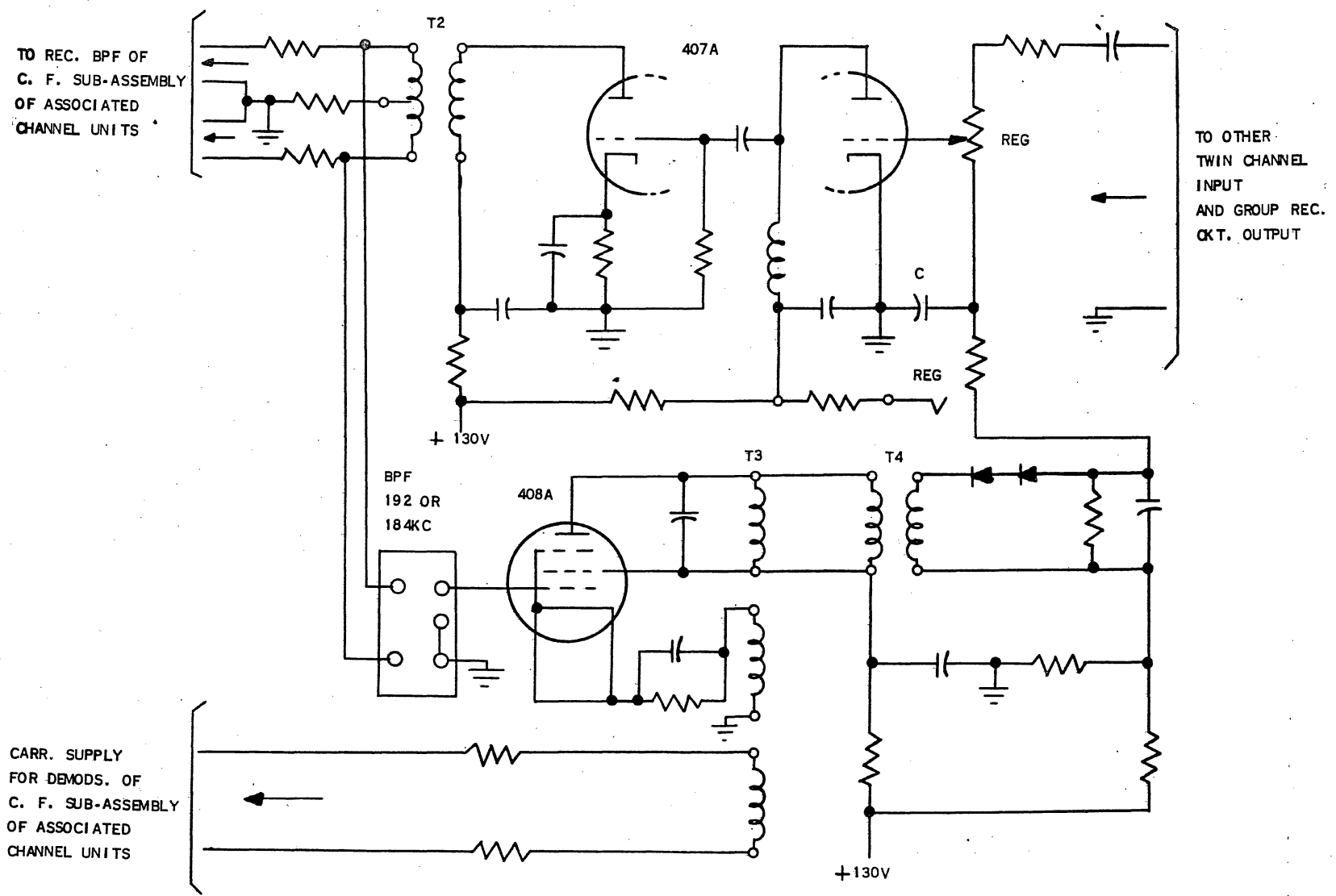

14.19

RECEIVING SIDE OF TWIN CHANNEL CARRIER CKT.
 OBI CARRIER
 Fig. 14-8

CHAPTER 14 TYPE "O" CARRIER SYSTEMS

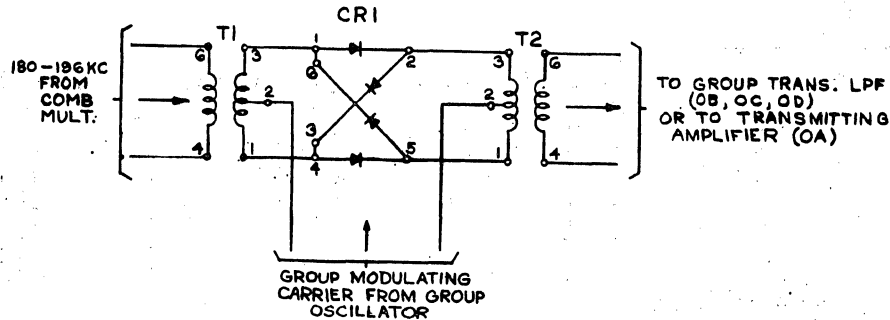

Figure 14-9 - Group Transmitting Modulator Schematic

The group receiving circuit performs five functions. A directional filter separates the two directions of transmission on the line. The low-level incoming line frequencies are amplified. The incoming line frequencies are group modulated to the range of the channel band filters, 180 to 196 kc. In addition the flat gain supplied is automatically controlled to compensate for line loss, including changing weather conditions. This regulation does not of course compensate for line slope or change in line slope. Finally, provision is made for operating an alarm circuit if the received carriers are lost.

This unit includes the directional filter for segregating the two frequency bands used for opposite directions of transmission over the line, the receiving group demodulator, band filters and amplifier, and the rectifier and amplifier for automatic transmission regulation of the receiving four channel group. The carrier alarm is also derived from this unit. The units used for high group and low group transmission are identical except for the position of the reversible plug-in filter and the code of the plug-in band filter associated with the demodulator. This unit when equipped with a different set of filters is identical with the amplifier unit in a repeater.

In the group modulator the regulated signals are shifted from the line frequencies to the 180- to 196-kc baseband. The modulator is the double-balanced-type in which both the input and modulating carrier frequencies are suppressed in the output. The output of the noise generator, located in the group transmitting circuit, is introduced into the circuit at the output of the group modulator. In the OB1, OC1, OD1 unit the bridging loss of the noise generator output impedance is one arm of a 4.3 db pad used to reduce the effect of the modulator impedance on the group receiving filter.

CHAPTER 14 TYPE "O" CARRIER SYSTEMS

The amplifier circuit is a 2-stage feedback amplifier similar to the amplifier of the group transmitting circuit. The simplified schematic of the amplifier is shown in Fig. 14-10.

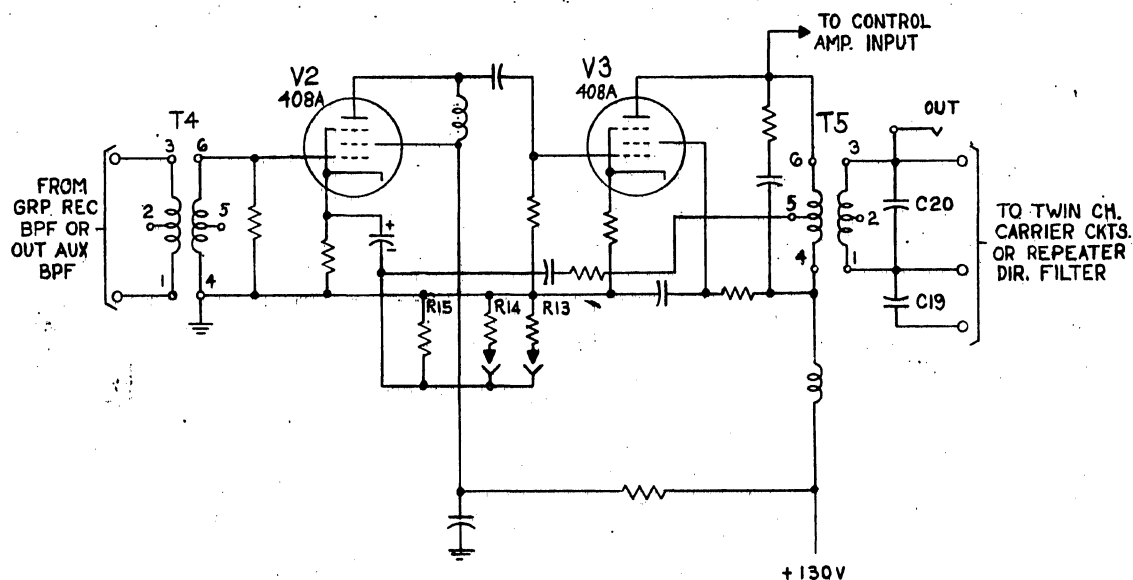

Figure 14-10
Amplifier of OB1, OC1, OD1 Group Receiving Circuit or Repeater

The control amplifier is a 408A tube employing cathode feedback, the output of which is rectified by a voltage doubler as shown in Fig. 14-11. The rectifier load is resistance R37 in series with the C relay, both located in the terminal mounting. So long as the incoming carriers are present the C relay will be held operated, but failure of the carriers releases the relay and results in an alarm. Bias for the regulating amplifier is obtained from the negative end of capacitor C18 but the net bias is the difference between the rectifier output and the positive reference voltage obtained from the voltage divider R30 and R29. The input of the control amplifier (Fig. 14-11) is coupled to the plate circuit of the group receiving amplifier by capacitor C14. Resistor R24 prevents a sudden increase in input from causing an overloaded locked-up condition of the group receiving unit.

CHAPTER 14 TYPE "O" CARRIER SYSTEMS

The output level at which the group receiving unit regulates is adjusted by means of potentiometer OUT. Changing this potentiometer changes the feedback and hence the gain of the contact amplifier, which in turn changes the bias on the regulating circuit. Lower contact amplifier gain reduces this bias and raises the group receiving circuit output level.

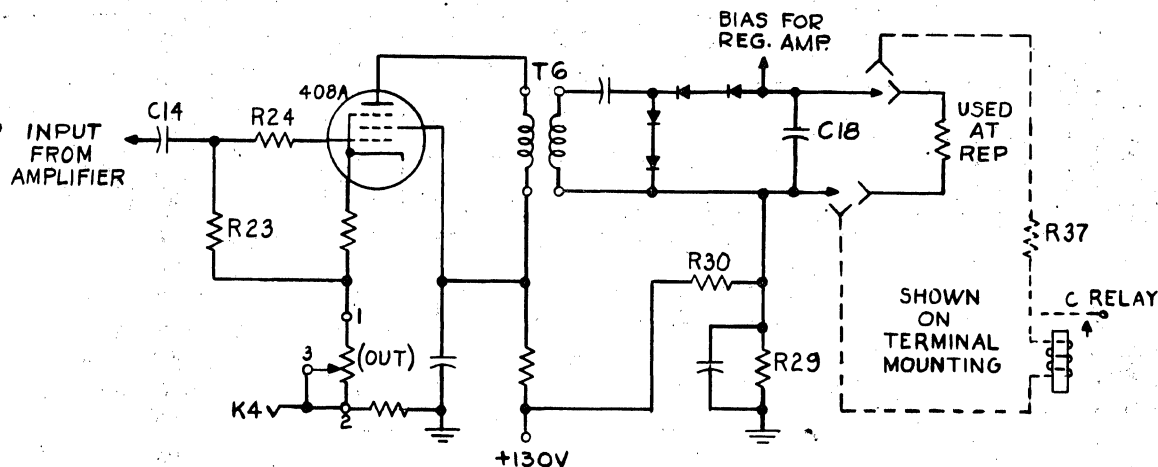

Figure 14-11 - Control Amplifier and Rectifier of O1 Group Receiving Circuits and of OB1, OC1, OD1 Repeater

The group oscillator unit comprises three oscillators: an RC thermistor-controlled oscillator generating 3700 cycles per second which supplies the signaling tone for the four channels, and two crystal oscillators, one of which supplies carrier to the modulator of the group transmitting circuit and the other to the modulator of the group receiving circuit. The frequencies of the crystal oscillators are 198 and 216 kc for the OAl group oscillator, 236 and 256 kc for the OB1, 276 and 296 for the OC1, and 316 and 336 kc for the OD1 unit. Provision is also made for supplying direct current, rectified from the 3700-cycle output, to an alarm relay located in the terminal mounting. Failure of the 3700-cycle output brings in an alarm.

In order to isolate the balanced line from the unbalanced directional filter of the terminal equipment, a line transformer is required. In the OAl terminal this transformer is mounted on the group receiving unit. In the OB1, OC1, and OD1 terminals the line transformer is mounted on a separate

CHAPTER 14 TYPE "O" CARRIER SYSTEMS

panel along with a network, or in case the terminal is connected to a carrier line in multiple with an OB1, OC1, or OD1 repeater, is part of a 200 L network. Between the transformer and the line is a set of jacks, one facing each way, to permit access the line and equipment for patching and maintenance purposes.

The repeater used in the OA carrier system performs three basic functions. It separates the two groups of frequencies used for the two directions of transmission on the open-wire line, amplifies the signals and transmits them to the line, and automatically regulates the gain to compensate for changes in line loss. OB1, OC1, and OD1 repeaters perform an additional basic function. They translate and invert the incoming group by modulation to the opposite group. That is, they are "frequency frogging" repeaters.

An OA1 repeater consists of a mounting, two networks on a line network panel, and three plug-in units: two repeater amplifiers and a dummy oscillator unit. Except for a plug-in auxiliary filter and strapping on a terminal block, the two repeater amplifiers are exactly alike. The dummy oscillator unit is used to complete the tube heater supply circuit.

An OB1, OC1, or OD1 repeater also consists of a mounting, associated networks on a line network panel, and three plug-in units: two repeater amplifiers which are exactly alike, and a repeater oscillator. The same mounting is used for all the O1 repeaters, and except for the plug-in filters the same repeater amplifier is used for OB1, OC1, and OD1 repeaters as well as for OB1, OC1, and OD1 group receiving units at terminals. A block schematic of an OB1 repeater is shown in Fig. 14-3. Schematics of the OC1 and OD1 repeaters are identical to that of the OB1 repeater except for the filters and frequencies involved.

An OA1, OB1, OC1, or OD1 repeater transmits the four message and signaling channels of the system on an equivalent 4-wire basis using two frequency groups, a low group and a high group for each system, for the two directions of transmission on the open-wire pair. The OA1 repeater has a low-group (E-W) and a high-group (W-E) repeater amplifier, each transmitting in one direction. Each OB1, OC1, or OD1 repeater has two identical repeater amplifiers, since they are frequency frogging repeaters. The OB1, OC1, and OD1 repeater may be arranged for HL operation (high-low receives high-group and transmits low-group frequencies of the system) or LH operation (low-high receives low-group and transmits high-group frequencies of the system) by properly plugging the proper directional and auxiliary filters into the repeater amplifier unit. The basic performance of the HL and LH repeaters of the OB, OC, and OD systems is the same except for the frequencies being received and transmitted. The two arrangements (LH and HL) are used alternately along the high-frequency line for a particular system.

CHAPTER 14 TYPE "O" CARRIER SYSTEMS

The OB, OC, and OD frequencies are separated from the OA frequencies or other lower frequencies on the line by a line filter. After passing through the line filter, the separated OA or OB, OC, and OD frequencies are transmitted through the line and equipment jack circuit (not furnished at pole mounted repeaters) and the line network circuit.

The carrier frequency used at each OB1, OC1, or OD1 repeater for group modulation is supplied by a crystal-controlled oscillator which is required to be very accurate in frequency so that the carriers will be translated the proper number of cycles in the process of frequency frogging. This is important to insure that when the carriers arrive at the terminal they will fall into the very narrow pass-bands of the pick-off filters of the twin-channel regulators. The carrier frequencies are 116 kc for OB1, 196 kc for OC1, and 276 kc for OD1 repeaters. The three oscillators are identical except for the crystal and two capacitors. A schematic is shown in Fig. 14-12.

The repeater oscillator is an electron-coupled crystal-controlled oscillator similar to those in the group oscillator and twin-channel circuits. The cathode, screen, and control grid of a 408A pentode operate as a triode oscillator with a tuned circuit employing a crystal as a positive reactance connected between the screen grid and control grid. Capacitor C2 in series with the crystal provides a frequency adjustment of about +20 to -12 cycles per second. Ordinarily this is adjusted in the factory only. Oscillations are coupled to the plate circuit of the pentode by the electron stream so that variations in modulator load have negligible influence on the oscillating circuit. The oscillations are transmitted from the plate to the modulator through an impedance-matching transformer which is tuned to improve the output waveform.

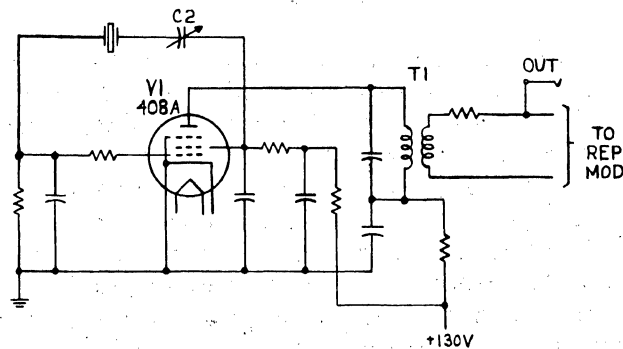

Figure 14-12 - OB1, OC1, OD1 Repeater
Oscillator Circuit

CHAPTER 14 TYPE "O" CARRIER SYSTEMS

14.5 SPECIAL FEATURES OF THE "O" CARRIER SYSTEM

Companders

The O system has been planned to take full advantage of a compander which is an integral part of each channel unit. This, together with frequency frogging, permits operation of O carrier under conditions which would otherwise entail substantially greater expense for mitigating the effects of noise and direct and interaction crosstalk.

A compandored circuit includes a compressor at the transmitting terminal and an expander at the receiving terminal. The compressor raises the weak speech levels so that they are transmitted over the line at a considerably high level, thus improving materially the signal-to-noise ratio. Since strong speech signals are already of sufficiently high level to override noise and crosstalk they are transmitted over the line with little or no change in level. At the expander the reverse process occurs which restores the speech to its original level.

Frequency Allocations and Frequency Frogging

The frequency allocations of the type O systems are shown in Fig. 14-1. Fig. 14-2 shows, for the OB system, the modulating processes and frequencies involved in a system with two LGT terminals and an LH repeater. For two HGT terminals, and an HL repeater, the same figure applies if the arrows showing directions of transmission are reversed. For the OC and OD systems, different group carriers and, as a result, different line frequencies, and a different repeater modulating carrier are used; otherwise, the same figure applies. For the OA system; since no frequency frogging occurs at the repeater, there is no repeater modulating carrier. Two different bands of frequencies are used for transmission over the line. This permits transmission in both directions on a single pair of wires.

Frequency frogging is an essential feature of the OB, OC, and OD systems. Without the interchange of frequency bands serious interaction crosstalk would be incurred. Because of the interchange of the frequency bands, repeater outputs at a repeater are always in one frequency group, and the inputs are in the other frequency group. The interaction crosstalk path around a single repeater is then between equal level points. As a result longitudinal coils and suppression filters are not generally required. In order to coordinate with the type C carrier, the repeaters of the OA system do not provide frequency frogging. This is feasible because of lower crosstalk couplings at OA frequencies. Another advantage of interchanging the frequency bands in the OB, OC, and OD systems is that the frogging repeater also inverts the frequency position of the channels and inverts each channel as shown in Fig. 13-2. Channel 4, the highest frequency channel in the high group, becomes the lowest channel in the low group and is also inverted. Because the line attenuation characteristic has a nearly

CHAPTER 14 TYPE "O" CARRIER SYSTEMS

constant slope, the effect of the line slope is nearly equalized in an even number of repeater sections, assuming equal repeater spacings, similar line facilities, and similar weather conditions for adjacent sections. The resulting advantage from the repeater-design standpoint is that a flat gain-frequency characteristic is adequate without slope equalizing or slope regulating networks. Further, the repeater gain needed is less so that appreciably less suppression is required in the directional filters at repeaters.

Signaling

The signaling system built into the terminal is arranged so that connection from the switchboard or trunk circuit is similar to that employed with present "CX" signaling circuits, that is, use is made of standard "E" and "M" lead signals. On-hook and off-hook dc signals, received as ground and battery potentials respectively on the "M" lead from the associated drop circuits, are transformed into corresponding interruptions of a 3700-cycle tone which is transmitted over the system as a sideband 3700-cycles away from the channel carrier. The on-hook or idle-circuit condition is indicated by the presence of the 3700-cycle tone; an off-hook or busy condition turns the tone off. Dial pulsing consists of turning the tone on and off under control of the opening and closing of the dial contacts. At the receiving end the tone interruptions are translated back into dc pulses on the "E" lead. For the on-hook condition the E lead is open; for off-hook the E lead is grounded. O carrier to O carrier connections can be made without use of a pulse link circuit. Similar direct connections can be made to N carrier, arranged for this use. A time-delay feature is provided in the 3700-cycle signal detector circuit to prevent registration of false pulses of short duration due to noise bursts and hits on the line. Another feature provides for disconnect of connected subscribers in the event of carrier failure. Where required in certain offices, circuits are automatically made busy by the carrier failure alarm to eliminate futile seizure of defective circuits.

Frequency Coordination

Coordination Between Type O Systems - Separation between OB, OC and OD systems, operating on the same pair, is provided by directional filters which are of the bandpass type. These filters are sufficiently selective to permit operation of all of these systems simultaneously on the same pair without regard to the relative directions of transmission of the different systems. In other words, any combination of high or low group transmission may be employed at any terminal or repeater point. However, the direction of transmission of each similar type of system must, of course, be coordinated in the same line section and, in general, the terminals and/or repeaters of similar systems at any one location should all transmit the

CHAPTER 14 TYPE "O" CARRIER SYSTEMS

same frequency group. The directional filters for the OA system are of the low-pass high-pass variety which cannot be operated directly in parallel with the directional band-pass filters of the other O systems. Separation of the OA system from the other types of the O carrier systems operating on the same pair is therefore accomplished by a line filter. Directions of transmission of the OA system need not be coordinated with those of the other O systems.

CHAPTER 15

TYPE ON CARRIER

15.1 ON CABLE CARRIER SYSTEMS

The type ON carrier system is made up principally of O1 carrier units with minor modifications and modified N1 carrier repeaters at each end of a standard type N line. This section describes the overall system aspects, the new features, and the modifications incorporated in some O1 and N1 units.

15.2 "ON1" CABLE CARRIER SYSTEMS

The type ON1 system is intended primarily to transmit type O carrier channels over two cable pairs equipped with N1 carrier repeaters. Using essentially standard O1 equipment and modified N1 repeaters at the cable terminals, up to 20 channels with the associated ten carriers may be transmitted over one type N line facility. Furthermore, one or two 20-channel ON1 systems can be transmitted over suitable radio facilities and either terminated or extended over cable or open-wire facilities.

Because of the ease of transition between cable and open wire, and because this transition can be made at any point, the ON system is adapted to open-wire, cable, and radio-link combinations. For example:

- (1) Any number of type O channels up to 20 can be installed at one end of the cable, transmitted over two pairs in the cable to a junction with one or more open-wire lines, and then distributed to the open-wire facilities in any way desired. The 20 channels might be divided among five OB systems on five separate open-wire pairs or connected to a family of OA, OB, OC, and OD systems on one pair, and a fifth system of any type on a second pair.
- (2) The cable can be located between two open-wire lines. It is not necessary that the cable terminate at a central office at either end. Alternatively, open-wire can occur between two cables.
- (3) The ON arrangement can be applied readily to radio systems either directly or through intervening cable or open wire.
- (4) Type ON channel terminals can be installed at each end of the cable to obtain a maximum of 20 all-cable circuits per quad in N cables.

Figure 15-2 shows the general layout for a typical 20-channel open-wire cable arrangement. A junction is made up of standard O1 group-receiving, group-transmitting, and oscillator units on the open wire side of the junction. The cable side of the junction consists of standard O1 group transmitted units and slightly modified O1 group-receiving and repeater-oscillator units.

CHAPTER 15 TYPE ON CARRIER

A terminal is made up of standard O1 channel units and group-transmitting units, and slightly modified O1 group-receiving, twin-channel, and group-oscillator units.

The ON1 repeaters located between the junction or the terminal and the type N carrier line are similar to N1 repeaters.

The all-cable ON arrangement providing up to 20 channels over two pairs or 1 quad is shown in Figure 15-1.

The ON1 system provides up to 20 single sideband channels instead of the 24 possible if the 12 double sideband channels in the N system were changed to single sideband. This reduction from the maximum number of channels permits the use of standard O1 equipment and filters with a minimum of modification and new codes, and retains the full flexibility of O systems on the open wire. Very flexible arrangements for adding or dropping groups of four channels at a cable, open wire junction are achieved through the use of the 4-channel groups derived from the O1 equipment as building blocks. There are five 4-channel groups in the ON system to make the total of 20 channels available. Figure 15-4 illustrates the flexibility of the system. When the full 5 group 20-channel capacity of the ON system is not used, a level-control oscillator is provided. The output of this oscillator is adjusted to simulate the power of the missing carriers to maintain the correct output level from regulating amplifiers in the N1 repeaters.

15.3 FREQUENCY ALLOCATION

Figure 15-5 shows a comparison of the frequency allocations of the type N and type ON systems. The ON allocation utilizes a low-group range from 40 to 136 kilocycles and a high-group range from 168 to 264 kc. Each frequency range is divided into five groups, each group containing four single sideband channels and two carriers.

The preferred order of adding ON1 groups in a partially equipped ON1 system in group 1 first followed by group 2 and group 3. Group 4 and 5 may then be added either order. The order of group 1, 2, and 3 is determined by the allocation of the level-control carrier.

Figure 15-5 shows the allocation of the level-control carrier in the ON low-group to be 76 kc. Coordination with N and ON systems that are in the same cable requires that the level-control carrier be located outside any channel in N or ON.

Both the terminal and junction equipment transmit and receive frequencies in the ON low-group range. The translation from low-group to high-group allocation or from high-group to low-group allocation is accomplished in the ON1 repeater.

Figure 15-1 Typical All Cable ON Layout

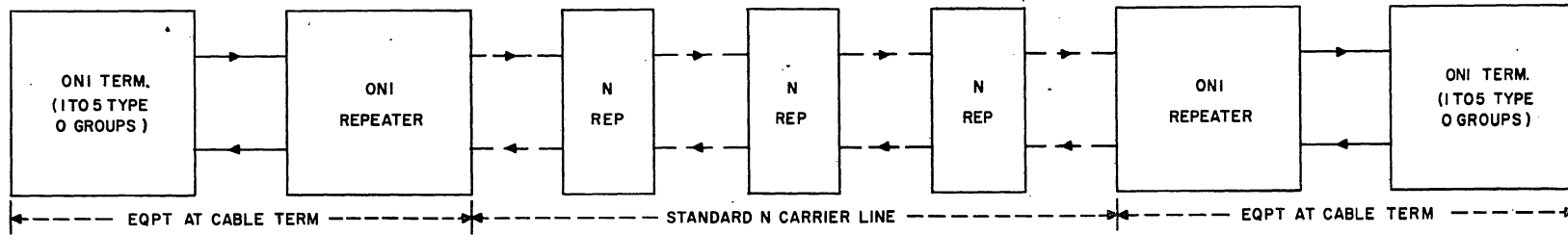

Figure 15-2 Typical Open Wire - Cable - Open Wire Layout

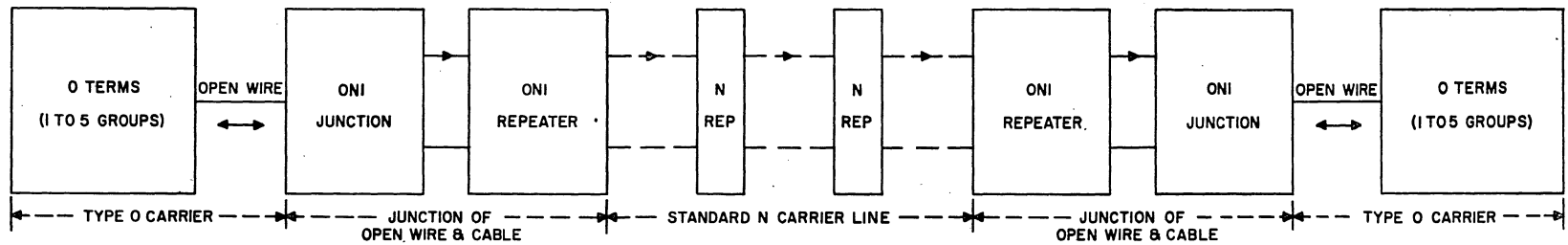
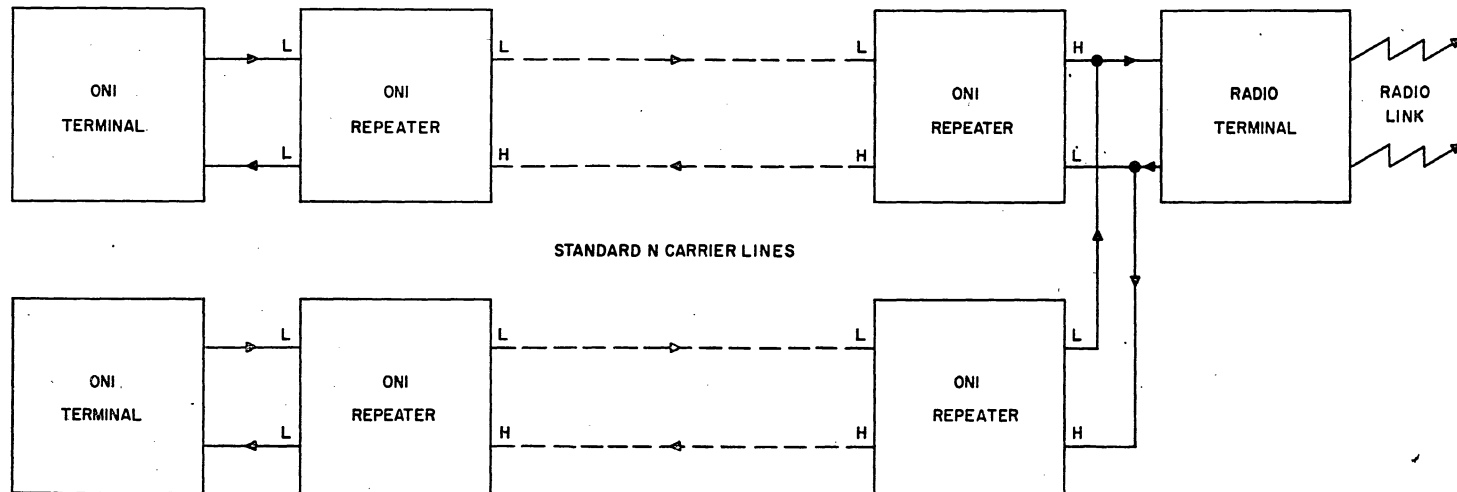

Figure 15-3 Typical Cable - Radio Layout



CHAPTER 15 TYPE ON CARRIER

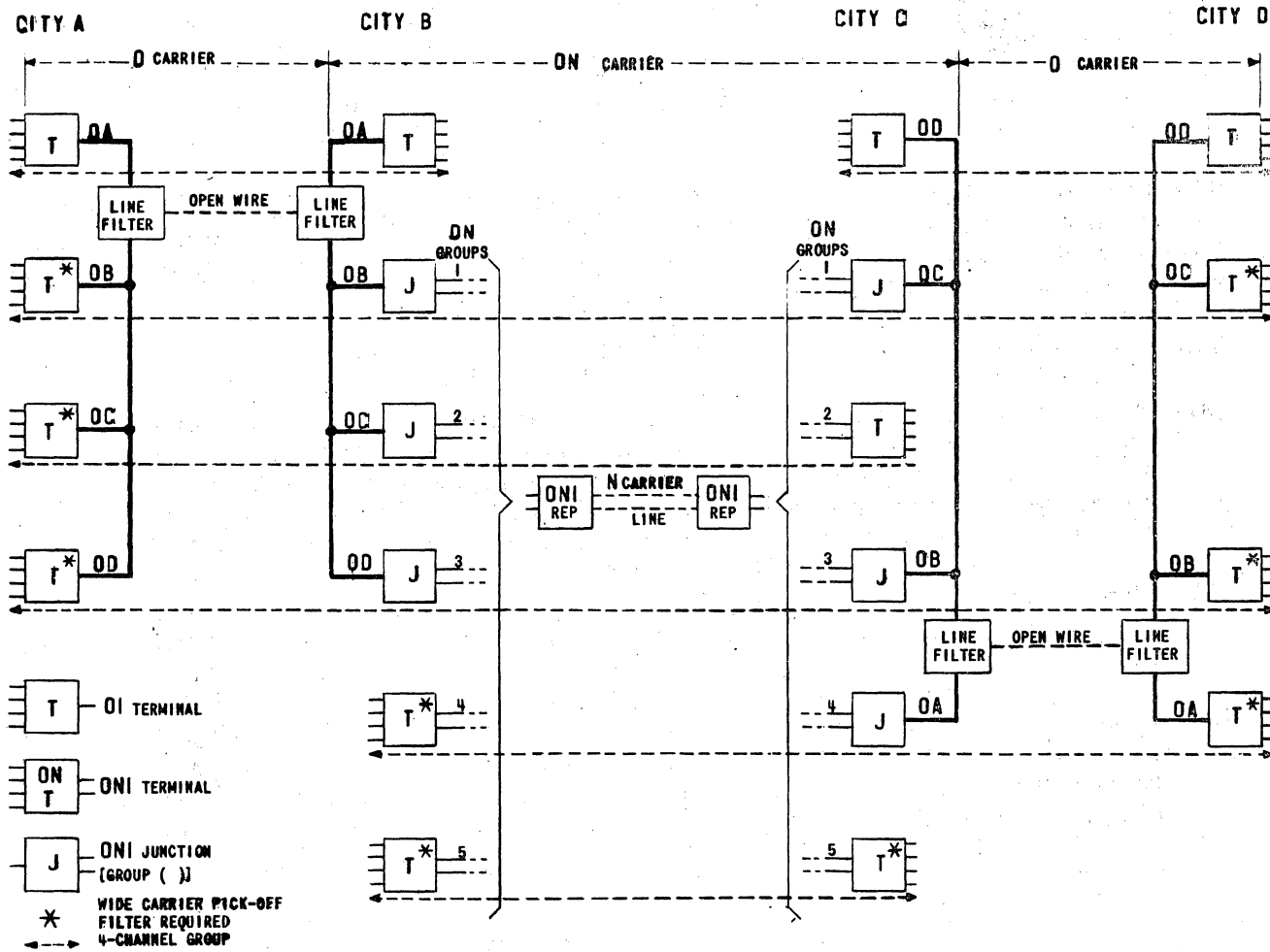

Fig. 15-4 Circuit Layout Illustrating Flexibility of ON Carrier

A complete ONI system employs a low-group frequency band, 40 to 136 kc., and a high-group band, 168 to 264 kc. The low-group band consists of five type O groups of four message channels each, as shown in the following table:

CHAPTER 15 TYPE ON CARRIER

<u>ON1 Group No.</u>	<u>Low Group Frequency</u>	<u>Corresponding O System Group</u>
5	40 to 56 kc.	OB low group
4	60 to 76 kc.	OB high group
3	80 to 96 kc.	OC low group
2	100 to 116 kc.	OC high group
1	120 to 136 kc.	OD low group

The high-group band consists of five similar groups modulated and inverted into the 168 to 264 kc. frequency band. The high-group and the low-group bands each provide for the transmission of 20 one-way message channels with associated E and M lead signaling. Refer to Fig. 15-6, 15-7, 15-8.

The ON1 system is applicable to the following facilities:

- (a) N-type Cable: For N-type cable applications, the low-group band is transmitted in one direction and the high-group in the other. The system thus provides up to 20 message channels over N-type cable, as opposed to the 12 channels of the N carrier system. As in the type N system, modulating type N repeaters frequency frog between the low- and high-group bands.
- (b) Radio: For radio applications a high-group band may be combined with a low-group band to provide up to 40 message channels (two ON1 systems) for transmission over the radio. Each ON1 system is transmitted high group in one direction and low group in the other. Figure 15-3.
- (c) K-type Cable: Three groups of ON1 carrier in the low-group band (groups 1, 2, and 3) may be transmitted over the same cable pair with K carrier. This arrangement, designated ON/K, provides 12 message channels in addition to the 12 channels of the K system. See Section 15.5.

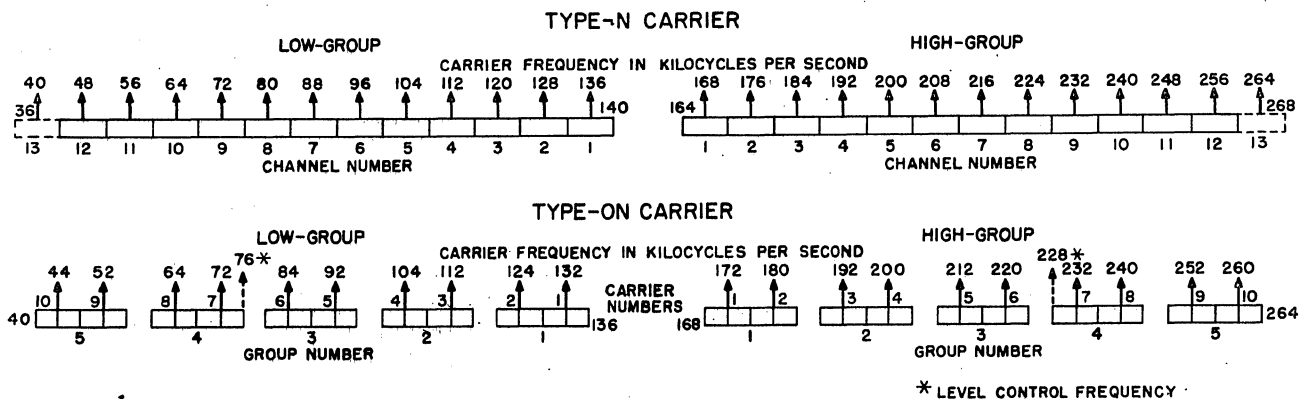

Fig. 15-5 ON and N Carrier Frequency Allocations

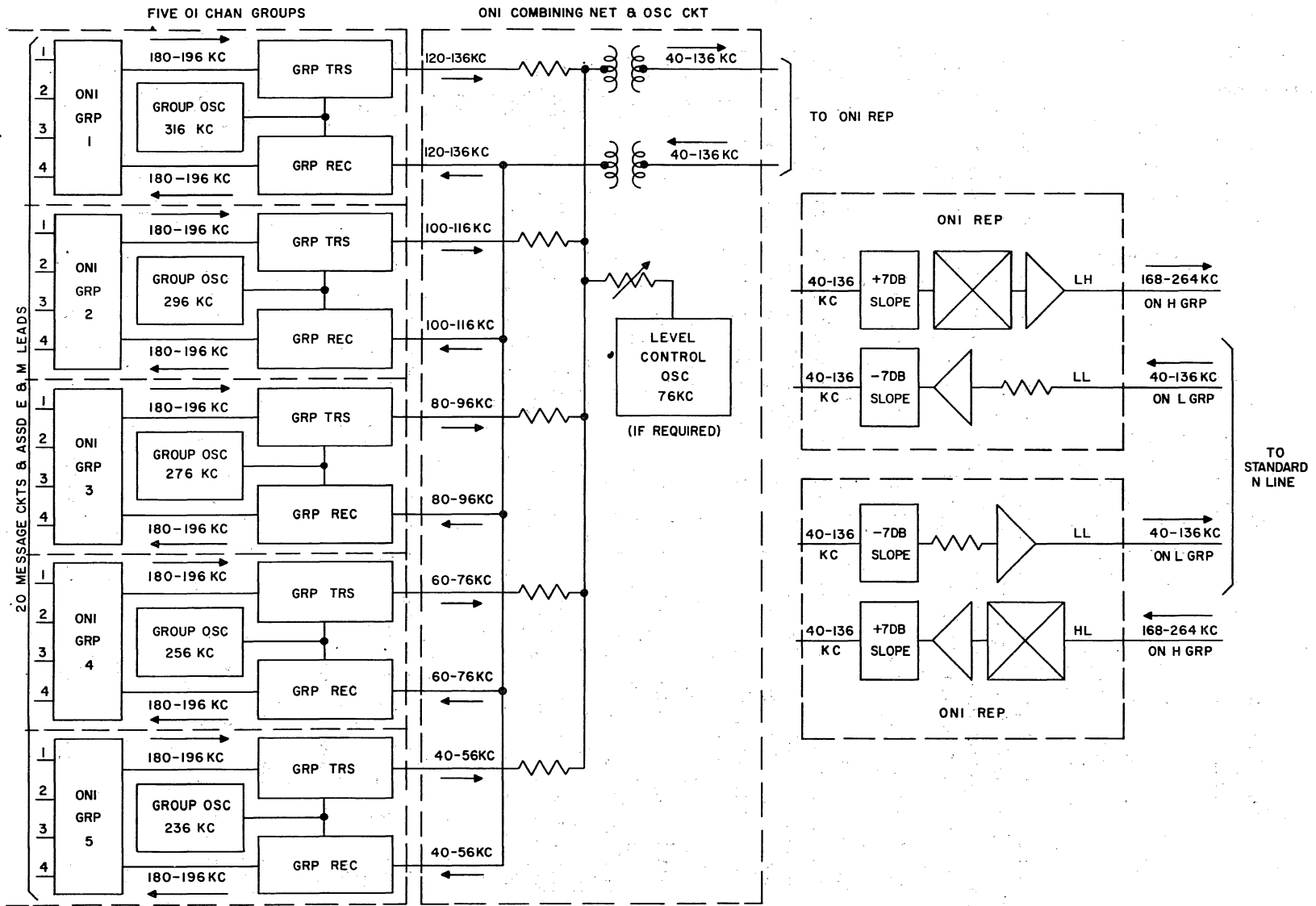

Fig.15-6 ON1 Carrier Terminal All Cable

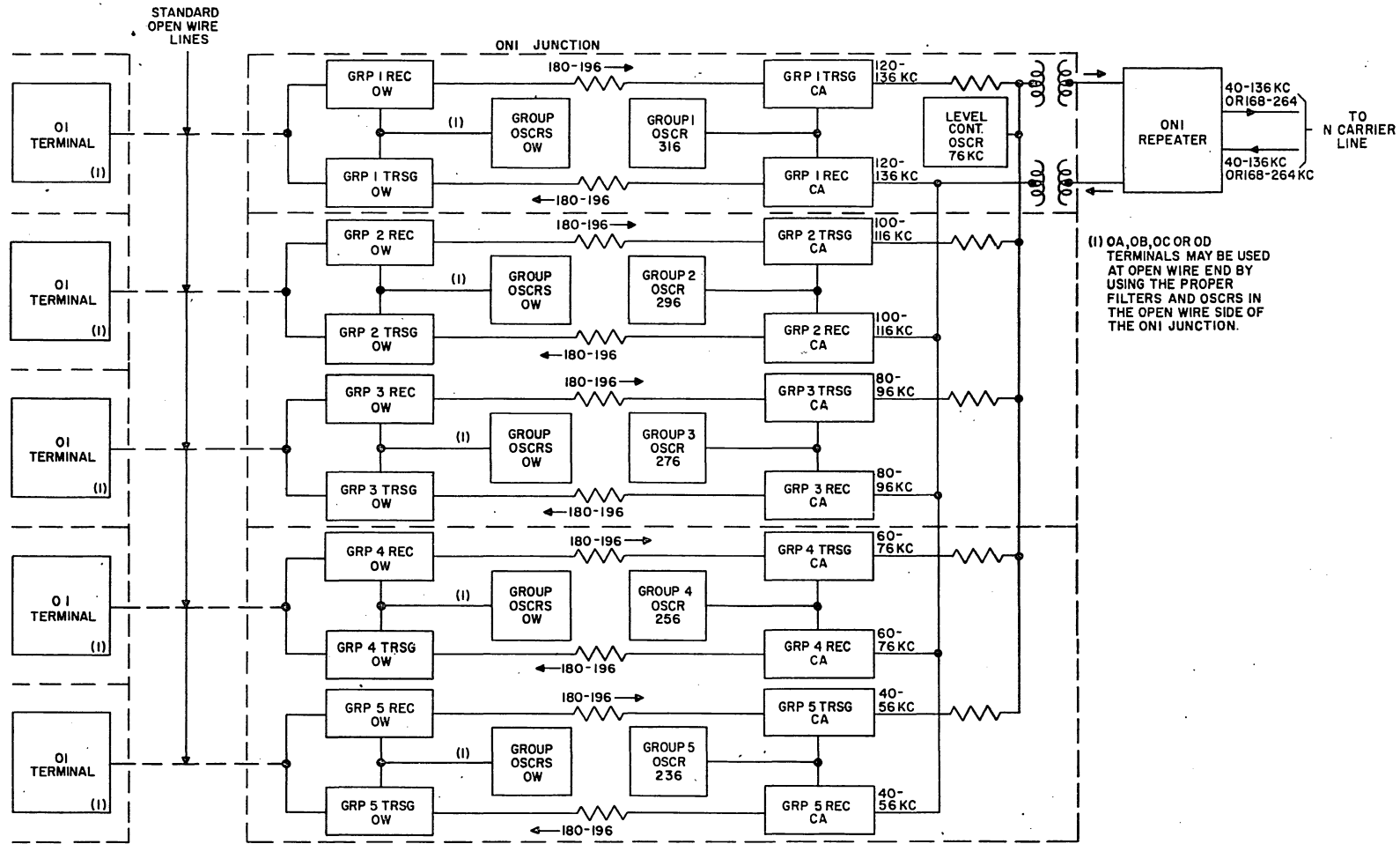

Fig. 15-7 ONI Carrier Open Wire - Cable Junction

15.8

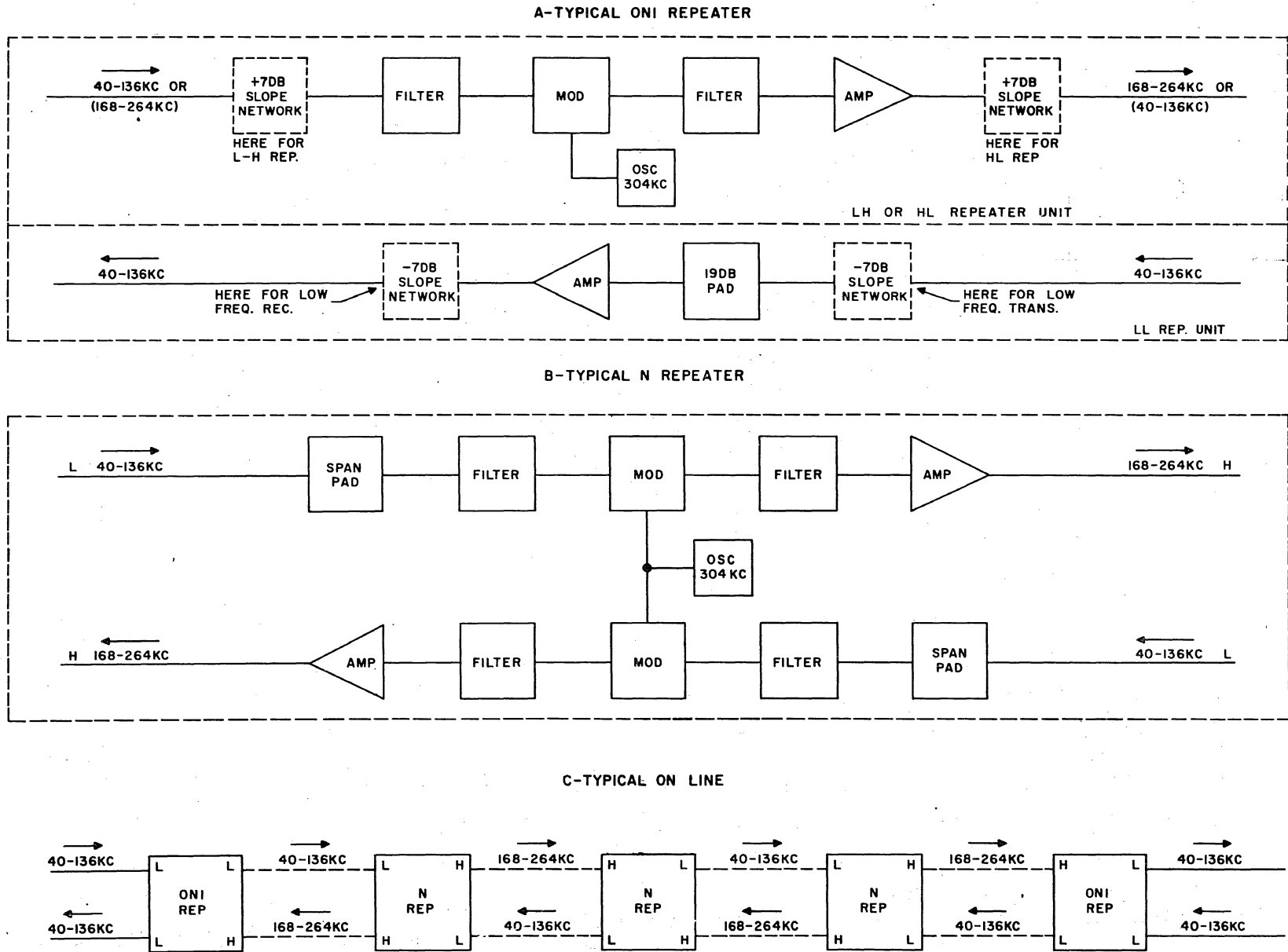

Fig. 15-8 Typical ON Arrangements

CHAPTER 15 TYPE ON CARRIER

15.4 TYPE ON2 CABLE CARRIER SYSTEM

In order to more fully utilize the frequency carrying capabilities of the N type high frequency line and of some microwave radio systems a new version of the ON carrier system has been developed. This new system is known as the ON2 and provides 24 voice-frequency channels as compared to the 20 obtainable with ON1.

The ON2 carrier can be used for systems to be operated over all cable, all radio, and cable-radio combinations. Carrier frequency junction equipment for cable-open wire and radio-open wire systems require development of additional components which will not be available at this time. Therefore, the ON1 system or ON2 and O channels operated back-to-back may be used for these applications.

Standard arrangements will be available concurrently with the ON2 for stacking 4 of these systems so that up to 96 voice-frequency channels can be multiplexed on a single radio path.

The 24 channels of the ON2 system will be arranged at the terminal in the frequency band from 36 to 132 kc. (see Figure 15-9). For transmission on the line 36 to 132 kc. will be used as the low band and will be modulated with a 304 kc. oscillator to produce 172 to 268 kc. which will be the high band. The resultant carriers will be the same as those of channels 2 to 13 of the N1 carrier system.

Like the ON1, the ON2 is basically an arrangement of stacked O carrier terminals which are combined for transmission over an N1 carrier line. The ON2 uses a stack of 6 of these 4 channel terminals in order to obtain a total of 24 channels (see Figure 15-9). As indicated in Figure 15-9 the only difference in the 4 channel terminals used for ON2 as compared to ON1 are in the group oscillator and the group receiver. Also the combining network of the ON2 terminal has been redesigned to provide for 6 groups.

No changes are to be made in the line arrangements for ON2 carrier systems. This includes the ON repeaters at the terminals as well as the N carrier high frequency line.

The ON2 is an all cable carrier system and basic unit of the 96 channel multiplex. The cable-open wire junction for the ON2 requires further study. In the meantime, the ON1 or back-to-back terminals can be used for such applications and for use where it is necessary to drop and reinsert four-channel groups at an intermediate point on an ON system.

In general, ON2 systems are engineered in the same manner as ON1 systems. However, since the frequencies of the carriers in the ON2 are the same as those of the channel 2-13 N1 system, the N1 deviation regulator can be used

CHAPTER 15 TYPE ON CARRIER

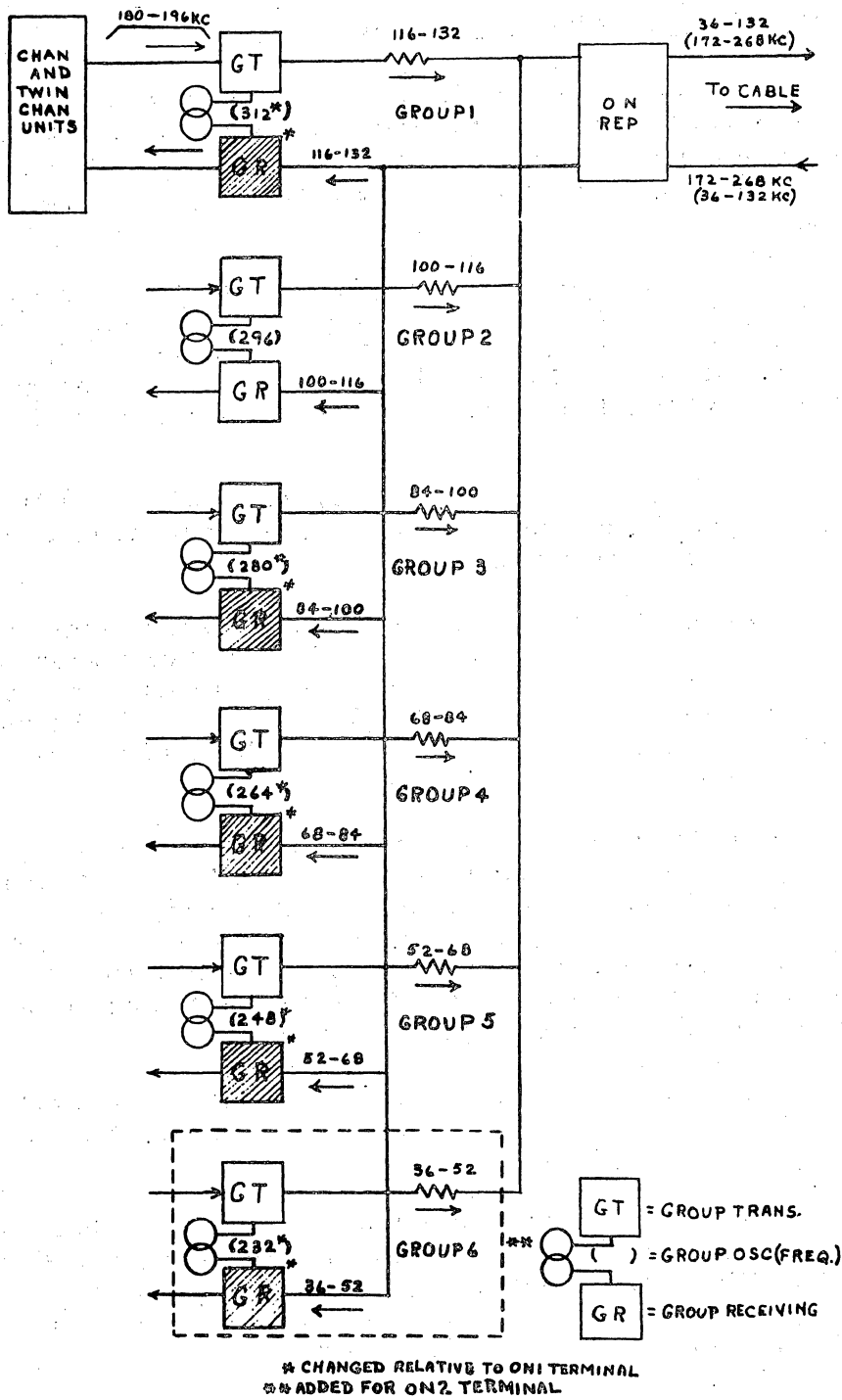

Figure 15-9 Block Diagram of 24 Channel ON2 Terminal

CHAPTER 15 TYPE ON CARRIER

to supplement the normal built-in regulation of the longer ON2 systems. Since the regulator requires the presence of twelve carriers in order to function properly, the systems with which it is used should be fully equipped.

The ON2 arrangement employs a maximum of 12 carrier frequencies which are the same as the carriers of channels 2 to 13 of the N1 system. Therefore, on a fully equipped system will be the same. For partially equipped ON2 the 76 kc. level control oscillator (LCO) will be used to replace the power represented by the missing carriers and thereby enable the amplifiers to regulate at the proper level. The LCO falls between channels 2 and 3 of group 4; and due to the limited selectivity of the channel filters, it will interfere with the signaling of these channels. Therefore, group 4 is the last to be equipped.

The noise and crosstalk aspects of the ON2 system are the same as for the ON1 for all practical purposes. No difficulty is expected when ON2 systems are operated in the same cable with ON1 or N1 systems.

15.5 TYPE ON/K CABLE CARRIER SYSTEM

On a type K carrier route one of the two cables provided is usually larger than the other and the non K pairs in the larger cables are used for shorter voice or carrier circuits. However, there are some layouts where two cables of approximately equal size were installed with only a relatively few pairs for short haul circuit development. The ON/K system has been designed to provide relief for short haul facilities on such routes to defer the large expense of establishing a new route.

The ON/K system makes it possible to use the 12 channels of the type ON1 low-group (16 channels of the ON2 when it becomes available) which are in the frequency range above that of the type K system, and like the K, it transfers from one sheath to the other at each repeater. However, it is separated from the K at terminals and repeaters by line filters and uses its own amplifiers. A block diagram of the arrangement is shown in Fig. 15-10.

The ON/K line arrangements make available line frequencies from 68 to 136 kc. The 12 channel ON1/K will use line frequencies from 80-136 kc. When the ON2 becomes available more efficient use will be made of the available frequency space and 16 channels will operate in the 68-132 kc. line frequency range.

As indicated on Figure 15-10, the ON/K terminal initially consists of ON1 Groups 1, 2 and 3, a combining network, new transmitting and receiving amplifiers, and line filters. Conversion of the ON1/K systems to ON2/K systems will involve providing one additional four channel group, replacing the plug-in group oscillators and group receiving filters of the existing equipment, and the addition of a mop-up equalizer.

CHAPTER 15 TYPE ON CARRIER

The highest ON/K carrier line frequency employed is 136 kc. The attenuation of 19 ga quadded cable at 136 kc. and at 55° Fahrenheit is about 5.5 db per mile. Therefore, gain of approximately 99 db is required to overcome the line loss in an 18 mile repeater section at the mean temperature. Roughly half of this gain is provided by the transmitting amplifier and half by the receiving amplifier.

At repeater points in the ON/K system line filters, a receiving amplifier, line building-out, and a transmitting amplifier are required for both directions of transmission.

At K repeater or terminal points where the ON/K leaves the K line and is extended to a distant terminal as a partial ON system over an N carrier line, the ON/K amplifier arrangements are similar to those used at a terminal (see Figure 15-11). This arrangement is called an ON/K junction circuit. For extension over cable facilities the signal at the output of the ON/K junction is applied to an ON/K to ON1 connection circuit and a standard ON repeater.

Regulation is adequate for the satisfactory operation of ON/K systems in buried cable for lengths up to 200 miles. The range of cable temperature for aerial construction is generally considered 2.5 times that for buried cables. Thus, for combined buried and aerial cable systems, the 200 mile regulation length would apply to the sum of the actual buried cable miles and 2.5 times the aerial cable miles. Where distances greater than 200 miles are to be spanned, it will be necessary to consider in each specific case the exposure to noise, the lengths of individual repeater sections and the regulation characteristics of the equipment. No need for deviation regulators is expected for systems of nominal length, therefore there are no plans to develop one for ON/K systems.

In general the K system will be of greater length than the ON/K system, and arrangements to join and leave the K pairs will be required. In order to simplify the layout and reduce interference to the K line, they should only be applied at K repeater stations. Arrangements are available to extend the systems at carrier frequencies over other types of facilities without returning to voice frequencies.

As a result of the low levels and high gains employed in the ON/K system considerable care is necessary to keep the noise within bounds. Careful design of the terminals and repeaters has resulted in minimizing the noise contributed by the equipment so that the controlling noise is expected to be picked up in the cable and the office layouts. However, due to the high gains, the amount of noise contributed by the equipment in the ON/K system is higher than in other carrier systems and will restrict the amount of improvement possible by line treatment.

The existing crosstalk balancing on the K cables is less effective in the ON/K

CHAPTER 15 TYPE ON CARRIER

than in the K frequency range but the compandors in the ON terminals will prevent this component of crosstalk from becoming objectionable. Interaction at the repeaters appears to be the controlling crosstalk source. However, the grounding of the shields of the wiring to the K equipment, and replacement of suppression coils to reduce the noise as discussed above will have a beneficial effect on crosstalk as well and no further crosstalk suppression measures appear to be necessary.

15.6 "ON" MODULATION PLAN

The type ON carrier modulation plan, shown in Fig. 15-12, is designed to place five different 4-channel groups, each corresponding to a type O group or system, in a frequency band capable of being transmitted over a type N line. The plan is based on the use of the basic 4-channel band of 180 to 196 kc. provided by the type O equipment. Each basic 4-channel group is modulated to an allocated ON low-group position by use of a group modulator and associated oscillator frequency, according to Fig. 15-12. The full ON complement of five groups covers the frequency range from 40 to 136 kc. When the system layout requires that transmission to the first repeater section be in the low-group band in order to coordinate with type N systems, or for other reasons, the band of frequencies from 40 to 136 kc. is applied to the line by the ON1 repeater without further modulation. When transmission in the high group is required, the ON1 repeater applies a further step of modulation with a carrier frequency of 304 kc. so that the ON low group is converted to the ON high group. Modulation in the repeaters along the type N line frequency-frogs these bands of frequencies back and forth between low group and high group in a manner identical to the type N plan. The ON modulation plan is a 2-step process when applied at the junction of open wire and cable. 4-channel groups are received on the open-wire line side of the junction of type O line frequencies. Each is then modulated to the basic 4-channel band of 180 to 196 kc. This band of frequencies is referred to as the base band. The second step modulates each group to its ON low-group allocation. Because the base band is common to each of the OA, OB, OC, and OD systems, it follows that the five groups of ON may be connected to any combination of O systems.

The ON modulation plan, as described above, applies to the transmitting direction and represents the modulation steps applied in going from the base band of the ON1 junction or terminal to the frequencies applied to the pair in the cable. In the receiving direction, the process is reversed. Frequencies are received from the N line in the high- or low-group band opposite in frequency to that transmitted from the same junction or terminal. When the frequencies arriving on the receiving cable pair are in the ON low-group band, the ON1 repeater supplies amplification without modulation. Selection and modulation in 4-channel groups is then carried out by the junction or terminal by properly allocated filters and group-oscillator frequencies.

When the received signals are in the ON high-group band, the ON1 repeater supplies a step of modulation to convert these to the low-group band for proper selection in 4-channel groups.

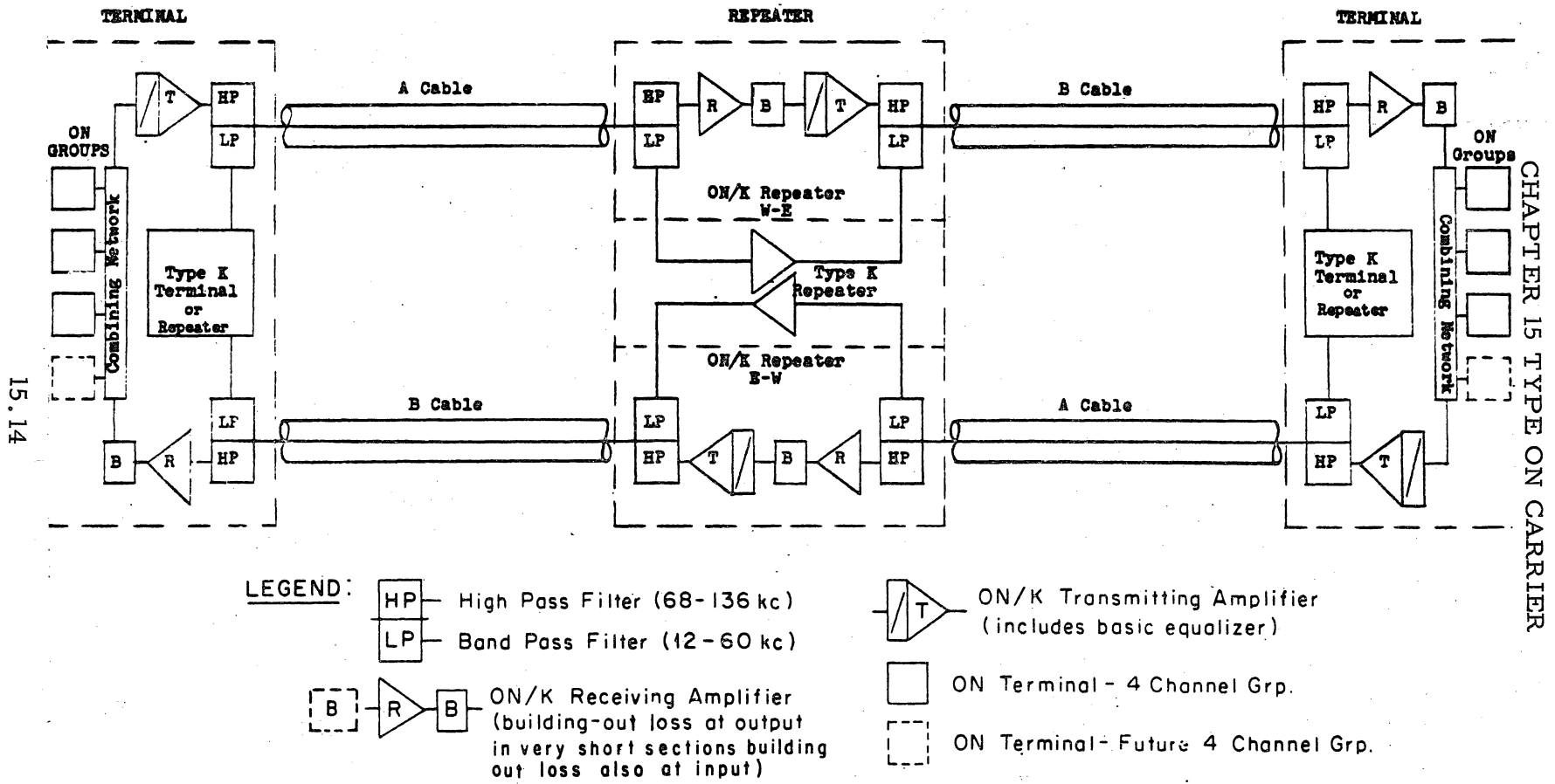
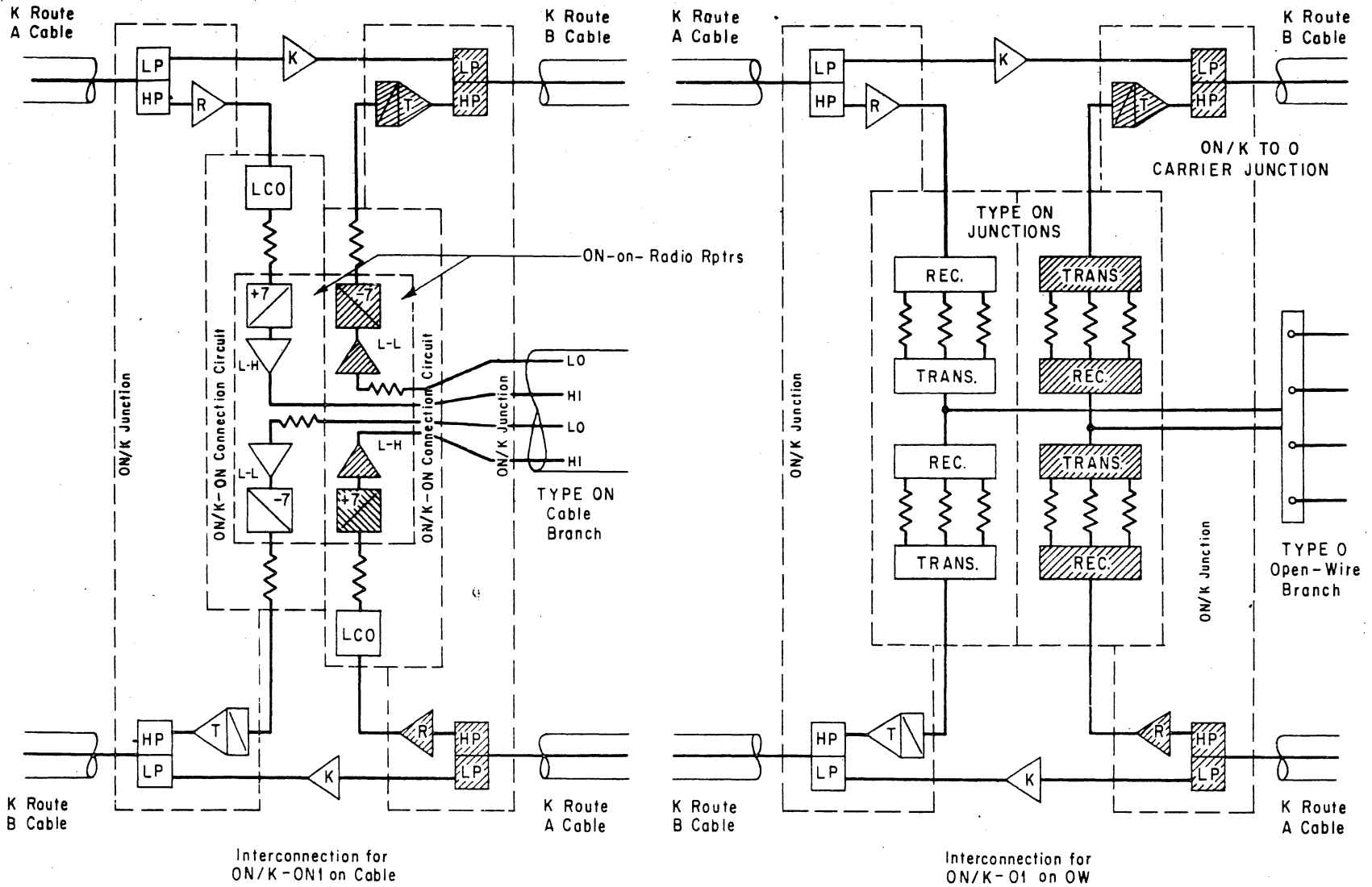

Figure 15-10 Type ON/K Carrier System Block Diagram



NOTE: Shaded Items may be omitted for simple drop, without reinsertion

Figure 15-11 Block Diagram On ON/K Junction Arrangements

CHAPTER 15 TYPE ON CARRIER

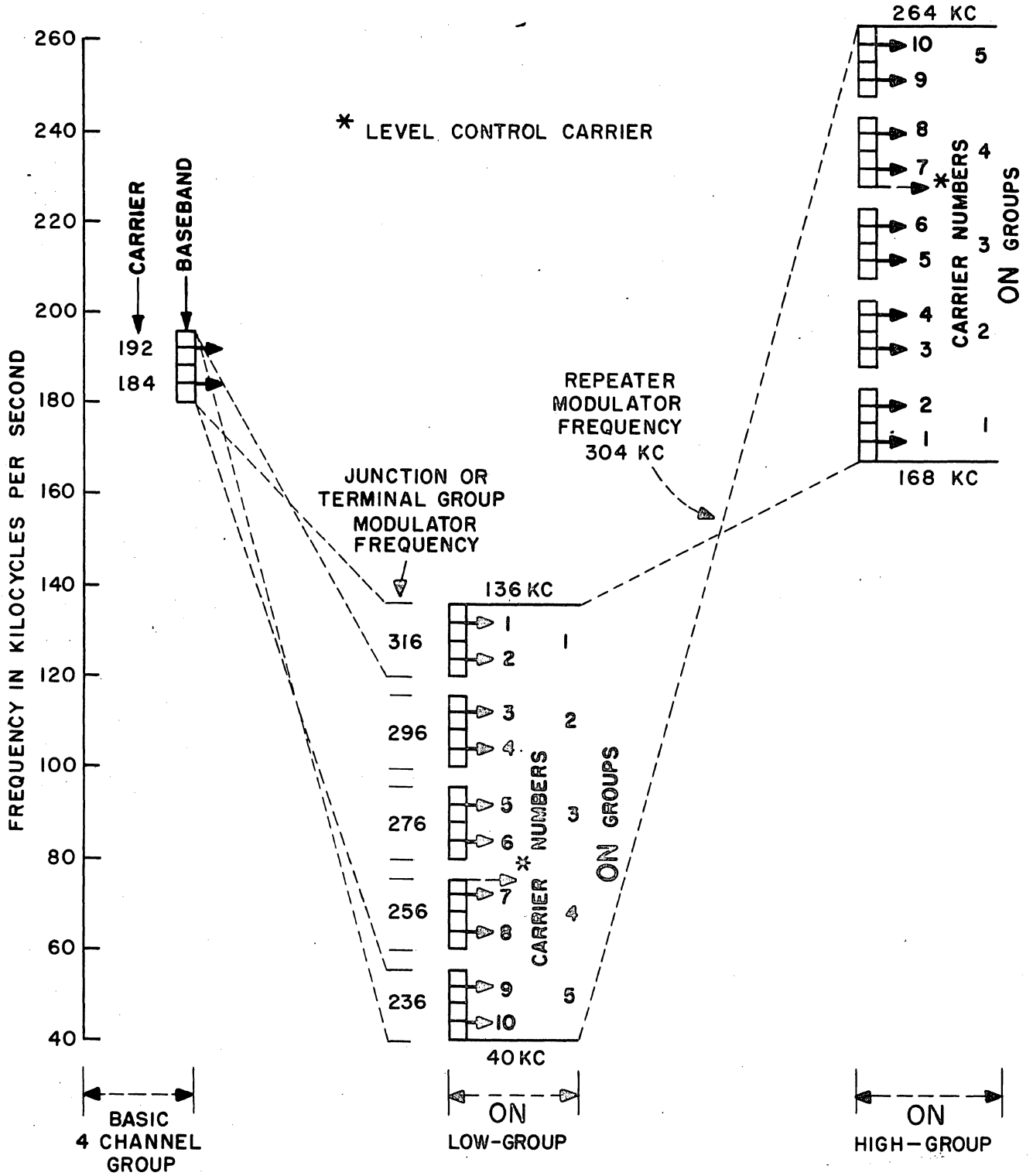

Fig. 15-12 ON Carrier System Modulation Plan

CHAPTER 16

PULSE CODE MODULATION AND T1 CARRIER

16.1 PULSE CODE MODULATION

In amplitude or frequency modulation the amplitude or frequency of a sinusoidal carrier is continuously varied in accordance with the modulating function. In contrast with this, pulse code modulation uses a series of pulses instead of a sinusoidal carrier to carry the information contained in the modulating function. Transmission by pulse code modulation involves sampling, quantization, coding, time division multiplex transmission, recognition, regeneration, and, ultimately, decoding.

16.2 SAMPLING

A transmitted "message" is usually thought of as a voltage which varies continuously with time. This is the modulating function. In AM or FM systems the carrier is varied continuously in accordance with their modulating function. In pulse modulation the continuous transmission of information about the modulating function is unnecessary.

In a practical transmission system the message or modulating function is limited to a finite frequency band. In order to transmit a band-limited message of a specific duration, it is not necessary to send the continuous function of time. The application of the following sampling principle reduces the problem of transmitting a continuously varying message to one of transmitting a finite number of amplitude values (samples):

Sampling Principle

If a message that is a magnitude-time function is sampled instantaneously at regular intervals and at a rate which is twice the highest significant message frequency, then the samples contain all the information of the original message.

Therefore, for voice frequencies, where the highest significant frequency is approximately 4,000 Cps, a sampling rate of 8,000 times a second would be adequate.

The process of sampling is illustrated in Figure 16-1. The function $f_1(t)$ illustrated in Figure 1(a) is assumed to contain no frequencies above f_c . Figure 1(b) shows a sampling function $f_2(t)$. The sampling frequency is

CHAPTER 16 PULSE CODE MODULATION AND T1 CARRIER

$2f_c$. The result of sampling is shown in Figure 1(c). This function, $f_3(t)$, is defined analytically as the product $f_1(t) f_2(t)$ and is a form of pulse amplitude modulation (PAM). Note that this is not instantaneous sampling, since the $f_2(t)$ pulses have duration. Instantaneous sampling can, of course, never be realized in a physical system.

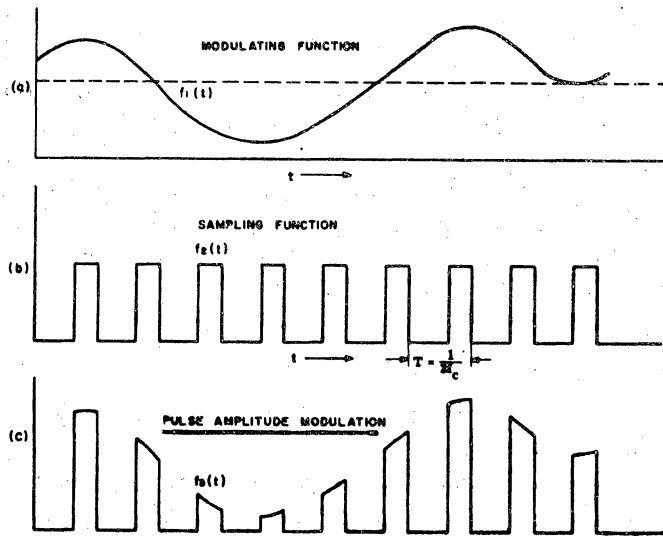

Sampling

Figure 16-1

16.3 RECONSTRUCTION

Let us now proceed to the receiving end of the system. The PAM signal, $f_3(t)$, may be transmitted to the receiver in any form which is convenient or desirable from the transmission standpoint. At the receiver the incoming signal is then operated on to recreate the original PAM sample values so that they appear in their original time sequence at a rate of $2f_c$ pulses per second. To reconstruct the message it is merely necessary to generate from each sample a proportional impulse, and to pass this regularly spaced series of impulses through an ideal low-pass filter of cutoff frequency f_c . Except for an over-all time delay and possibly a constant of proportionality, the output of this filter will then be identical to the original message.

Ideally, a perfect reproduction of a message can be achieved if information were transmitted giving the instantaneous amplitude of the message at intervals spaced $1/2 f_c$ apart in time. For example, if a sampling rate of

CHAPTER 16 PULSE CODE MODULATION AND T1 CARRIER

8,000 times per second and a pulse of one microsecond duration were assumed, the message in the transmission facility would be represented as a series of one-microsecond pulses occurring at intervals of 125 microseconds (1/8,000).

16.4 QUANTIZATION

It is, of course, impossible to transmit the exact amplitude of a modulating function. In conventional AM or FM, or in a system using pulse height or position to carry information, some error will always occur. Noise, distortion, and crosstalk will affect the modulated wave so that the recovered message will not exactly duplicate the information in the original message. In the systems noted - AM, FM, or PAM - the error increases as we go through successive repeater sections, since additional noise is added to the signal as it passes through each repeater section.

This situation is analagous to the accumulation of small errors in a long series of slide-rule operations. It suggests the weakness of an analog method of transmission in which the transmitted signal can assume a continuum of values. But suppose we consider instead a digital system. Instead of attempting the impossible task of transmitting the exact value of a sample, let us limit ourselves to certain discrete amplitudes of sample size. Then, when the message is sampled, the amplitude nearest the true amplitude is sent. When this is received and amplified, it will have an amplitude a little different from any of the specified discrete steps, because of the disturbances encountered in transmission. But if the noise and distortion are not too great, we can tell accurately which discrete amplitude the signal was supposed to have. Then the signal can be reformed, or a new signal created, which again has the amplitude originally sent.

Representing the message by allowing only certain discrete amplitudes is called quantizing. It inherently introduces an initial error in the amplitude of the samples, giving rise to quantization noise. But once the message information is in a quantized state, it can be relayed for any distance without further loss in quality, provided only that the added noise in the signal received at each repeater is not too great to prevent correct recognition of the particular amplitude each given signal is intended to represent. By quantizing we limit our "alphabet". If the received signal lies between a and b, and is closer (say) to b, we guess that b was sent. If the noise is small enough, we shall always be right.

16.5 CODING

A quantized sample could be sent as a single pulse which would have certain possible discrete amplitudes, or certain discrete positions with respect to a reference position. However, if many allowed sample amplitudes are required, one hundred, for example, it would be difficult to make circuits

to distinguish these, one from another. On the other hand, it is very easy to make a circuit which will tell whether or not a pulse is present. Suppose, then, that several pulses are used as a code group to describe the amplitude of a single sample. Each pulse can be on (1) or off (0). If there are three pulses, for instance, a code can be devised to represent the amplitudes shown in Table I.

TABLE I

<u>Amplitude Represented</u>	<u>Code</u>
0	000
1	001
2	010
3	011
4	100
5	101
6	110
7	111

These codes are, in fact, just the numbers (amplitudes) at the left written in binary notation. In this notation, the place values are 1, 2, 4, 8, -; i.e., a unit in the right-hand column represents 1, a unit in the middle (second) column represents 2, a unit in the left (third) column represents 4, etc. In general, a code group of non-off pulses can be used to represent 2^n amplitudes. For example, 7 pulses yield 128 sample levels. Figure 16-2 illustrates the coding of a PAM signal into seven digit code.

It is possible, of course, to code the amplitude in terms of a number of pulses which have allowed amplitudes of 0, 1, 2 (base 3 or ternary code), or 0, 1, 2, 3 (base 4 or quaternary code), etc., instead of the pulses with allowed amplitudes 0, 1 (base 2 or binary code). If ten levels were allowed for each pulse, then each pulse in a code group would be simply a digit or an ordinary decimal number expressing the amplitude of the sample. If n is the number of pulses and b is the base, the number of quantizing levels the code can express is b^n . However, binary code (0, 1) seems to offer the most advantages.

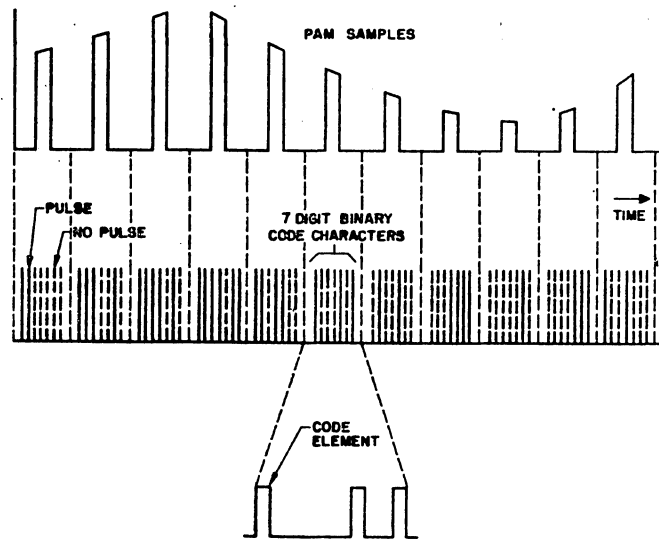

Binary Pulse Coding

Figure 16-2

16.6 DECODING

To decode a code group of the type just described, a pulse must be generated which is the linear sum of all the pulses in the group, each multiplied by its place value ($1, b, b^2, b^3, \dots$) in the code. This can be done in a number of ways. For example, we might mention what is perhaps the simplest way which has been used. This involves sending the code group with "units" pulse first, and the pulse with the highest place value last. The pulses are then stored as charge on a capacitor-resistor combination with a time constant ($T = RC$) such that the charge decreases by the factor $1/b$ between pulses. After the last pulse, the charge (voltage) is sampled. Such a method, while feasible, has the disadvantage that the most significant digit is in its fastest decay period when used, leading to large errors.

16.7 TIME DIVISION MULTIPLEX

There is an optimum rate for the transmission of short pulses through a band-limited medium. For a low-pass characteristic which transmits up to some frequency f_1 cps, $2f_1$ pulses per second can be sent. Thus a 750 kc channel could carry 1.5 million pulses per second. Consider the transmission of 4 kc telephone messages by 8 digit binary PCM over a channel which has a bandwidth of 750 kc/s.

CHAPTER 16 PULSE CODE MODULATION AND T1 CARRIER

It was previously seen that our sampling rate should be 8,000 times per second or one sample per 125 microseconds. Each sample will result in one code character consisting of eight code elements (1's or 0's). If we can send 1.5 million pulses per second, eight pulses can be sent in 5.33 microseconds. If only the information pertaining to one message is sent, the pulse pattern vs time would consist of an 8-pulse character, taking 5.33 microseconds, then idle time for about 120 microseconds, followed by another 5.33 microseconds of use, and so on. Obviously, the channel is not used very efficiently. On the other hand, if code characters from other channels are sent during the idle time, not one, but about 24 telephone messages could be transmitted over our 750 kc channel. Interleaving signals on a time basis in this way is called Time Division Multiplex.

An illustration of a time division multiplex PCM system is shown in Figure 16-3. Although a four channel system was chosen for convenience, the concepts associated with this system pertain equally well to a system involving any number of channels. Figure 16-3(a) shows four messages in the form of time-varying voltages which are to be transmitted over a common channel. Each message is band-limited to 4 kc by a low-pass filter in the message path. The problem is to sample each message, interleave the resulting PAM signals, and, finally, encode the PAM signals into binary PCM. For purposes of graphically illustrating the principle, the sampling mechanism is shown as a switch rotating at the required 8,000 cycles per second sampling rate. Such a switch combines the functions of sampling and interleaving. Figure 16-3(b) illustrates the interleaved PAM samples so obtained at the sampling circuit output. These samples are fed into an appropriate encoder circuit which produces a seven-digit PCM encoding of the incoming PAM signals. The encoder output is shown in Figure 16-3(b). At the receiving end the inverse functions of decoding and sample separation are performed, as illustrated by Figure 16-3(a).

Some useful terms can be defined from Figure 16-3. The sampling interval, T , shown for message channel 2, is the time between successive samples of the message voltage in a channel. A frame represents the output obtained from one complete cycle of the sampling circuit. The frame interval is equal in duration to the sampling interval and is the time required to obtain one complete frame. The frame rate is the reciprocal of the frame interval and is equal to the rate at which the frames are generated, which, of course, equals the sampling rate. Thus, for the system illustrated, the frame rate is 8,000 frames per second, and the frame interval (or sampling interval) equals 125 microseconds. The time interval for each code character (representing a sample from each message channel) must be equal to or less than one-fourth of the frame interval, if four message channels are to be accommodated.

CHAPTER 16 PULSE CODE MODULATION AND T1 CARRIER

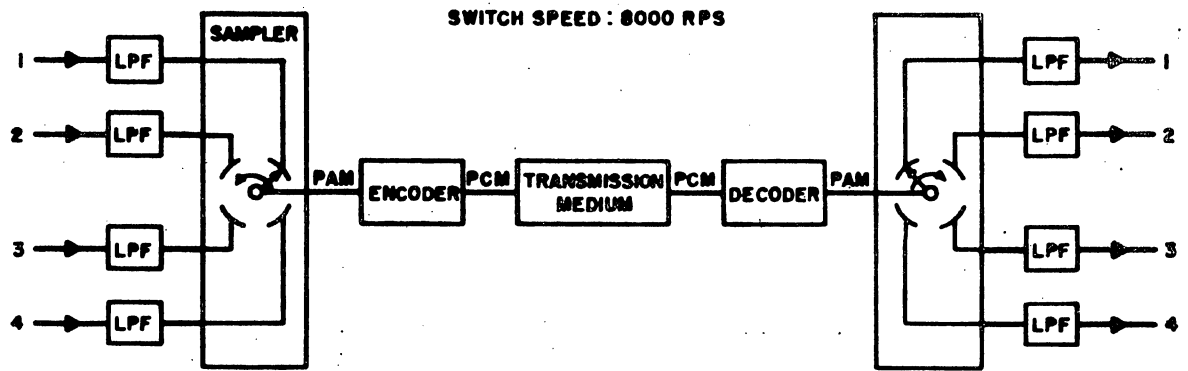

(a) ELEMENTS OF PCM SYSTEM

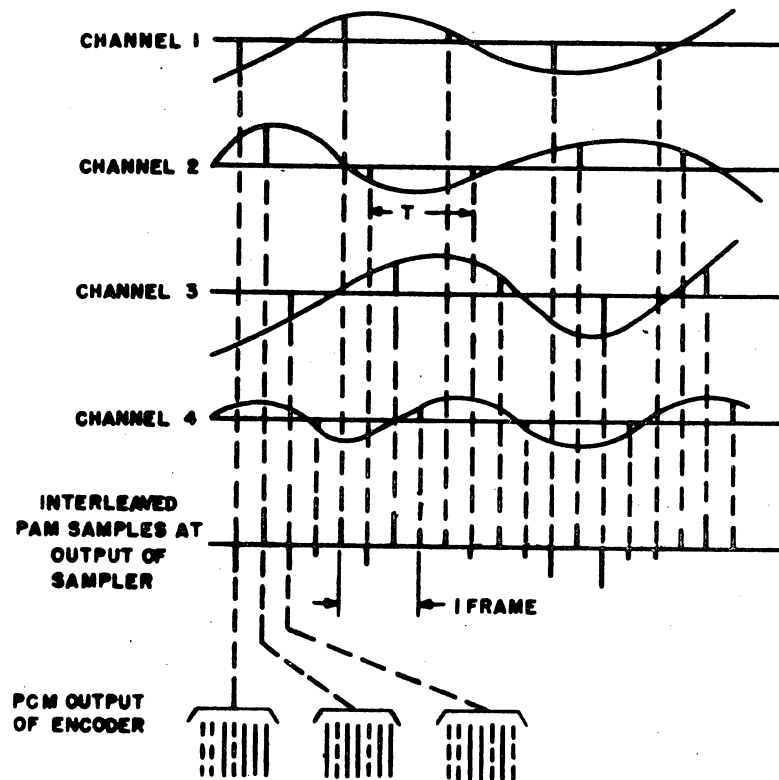

(b) FORMATION OF PAM AND PCM SIGNALS

Time Division Multiplex

Figure 16-3

CHAPTER 16 PULSE CODE MODULATION AND T1 CARRIER

Time division implies switching at precisely fixed times in order to separate the messages at the receiver. Therefore, additional time, within the frame interval, is usually allocated to some sort of timing or gating signal.

As the number of message channels is increased the time interval that can be allotted to each must be reduced since all of them must be fitted into the frame interval. The allowed duration of a coded pulse train representing an individual sample must be shortened and the individual pulses moved closer together as the number of time division channels in a frame is increased. This means that frequency limitations of the transmission medium inevitably restrict the number of message channels which can be included in a frame.

In general terms: if f_c cycles per second is the highest frequency in our message, and n the number of code elements per code character, then we require approximately nf_c cycles per second of bandwidth per message, plus an allowance for gating time. This is n times the bandwidth required for direct transmission or for single sideband AM. In terms of the preceding discussion, using $n=8$, and 24 channels was found to be consistent with a 750 kc bandwidth. This is about eight times the 96 kc bandwidth required for the single sideband AM transmission of 24 channels.

16.8 INTRODUCTION TO T1 CARRIER

A T1 Carrier System provides low-cost facilities for conveying the transmission and signaling information for 24 exchange trunks over a two-way carrier line. The multiplexing is done by time division methods in D1 Channel Banks shown in Figure 16-4. These terminals, designed for Central Office use, deliver pulse code modulation (PCM) signals to the line.

The T1 carrier system will be applicable to short-haul trunks. The principal market includes direct interoffice trunks, tandem trunks, toll connecting trunks, PBX trunks, PBX tie lines, and foreign exchange lines. Type T1 carrier will probably be used primarily in the larger metropolitan areas on trunk routes of large cross-section and relatively high growth rates.

The system must be closely tailored to the requirements imposed by its application if the cost objective is to be met. This has led to the provision of several plug-in equipment options, each designed for a specific application, rather than the provision of a universal facility that is capable of handling many different situations with the same equipment.

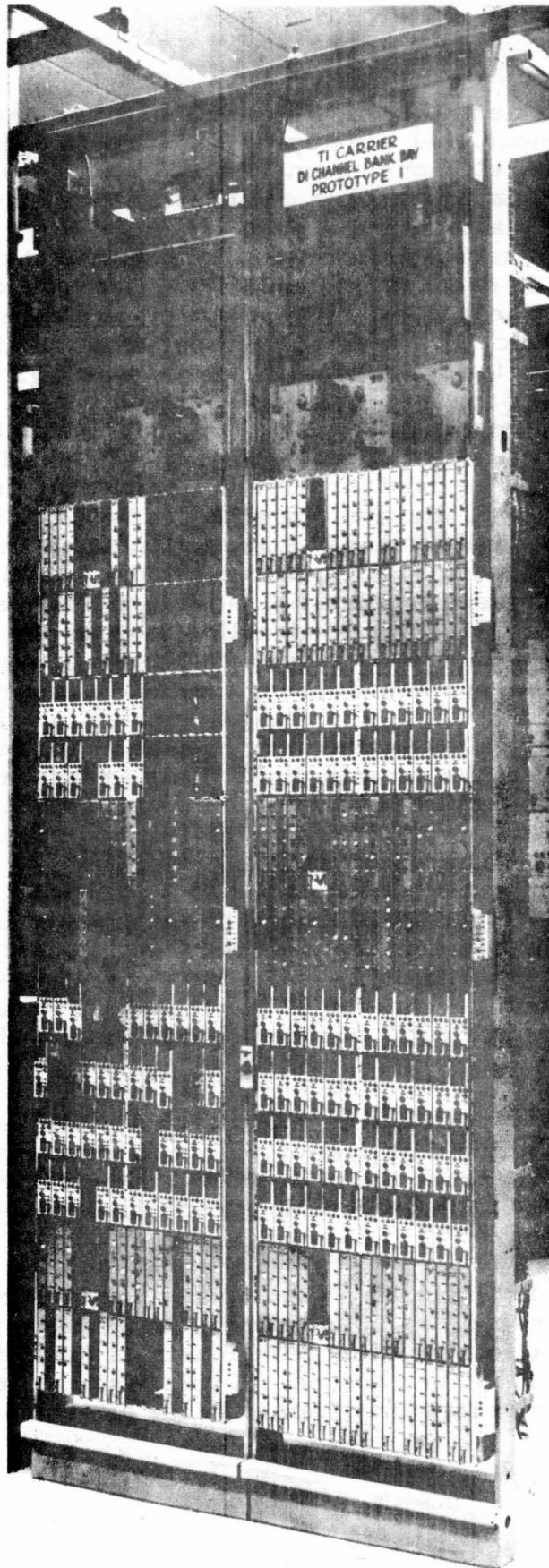

D1 Channel Bank Bay - 3 Bay Arrangement
Front View - 2 Bay Line Up
Figure 16-4

CHAPTER 16 PULSE CODE MODULATION AND T1 CARRIER

16.9 TERMINAL

In the type T1 carrier system, 24 voice channels are combined into a single pulse amplitude modulated wave by time division multiplexing. The sample rate for each telephone channel is 8,000 samples per second. The pulse amplitude modulated signal is compressed and encoded into a pulse code modulation signal for transmission over the line. A 7-digit code is used to represent each PAM sample. At the distant terminal, the received pulse train is decoded, expanded, amplified, and distributed to 24 low-pass filters. The low-pass filters extract the envelope of the received PAM pulses, which is a very close approximation to the original signal. The block diagram for the Terminal is shown in Fig. 16-5.

Built-in signaling arrangements for loop dial pulsing, revertive pulsing, and E&M lead signaling will be provided. The built-in loop dial pulse signaling arrangement may be used for supervision on multifrequency pulsing trunks. An additional digit will be added to the 7-digit code representing each PAM sample to carry signaling information. This increases the number of digits per sample to eight and provides a 2-state signaling channel which is adequate for dial pulse and E&M lead signaling. For revertive pulse signaling a 3-state signaling channel is required. The additional state will be obtained by removing control of the least significant digit (seventh digit in code representing the PAM sample) from the encoder while dialing is in process and using this pulse for signaling information. When the called party answers, returned answer supervision restores encoder control of the seventh digit. This arrangement slightly impairs (provides only 6-digit PCM quality) calls to lines that do not return answer supervision, such as calls to information operators, telephone business offices, repair desks, etc.

In a time division system, synchronization of the terminals at the two ends is essential. Synchronization includes both timing and framing. Timing is marking the individual pulse positions or times when a decision must be made as to whether or not a pulse is present. Framing is uniquely marking a particular pulse position so that the individual channel pulse positions are identifiable.

The transmitting section of the T1 terminal will obtain its timing information from a 1.544-mc crystal oscillator. This 1.544-mc wave will be transmitted as an integral part of the pulse train and extracted at each repeater along the line and at the receiving terminal, as discussed in 16.10, Repeater Operation.

Framing is accomplished by inserting a framing pulse position after each group of 24 coded samples. i. e., In addition to the 24 eight-pulse "words" in each frame, there is also a framing pulse making a total of 193 pulse-times per frame on 1,544,000 per second. A pulse is inserted in the framing pulse position on every other frame; on the alternate frames

CHAPTER 16 PULSE CODE MODULATION AND T1 CARRIER

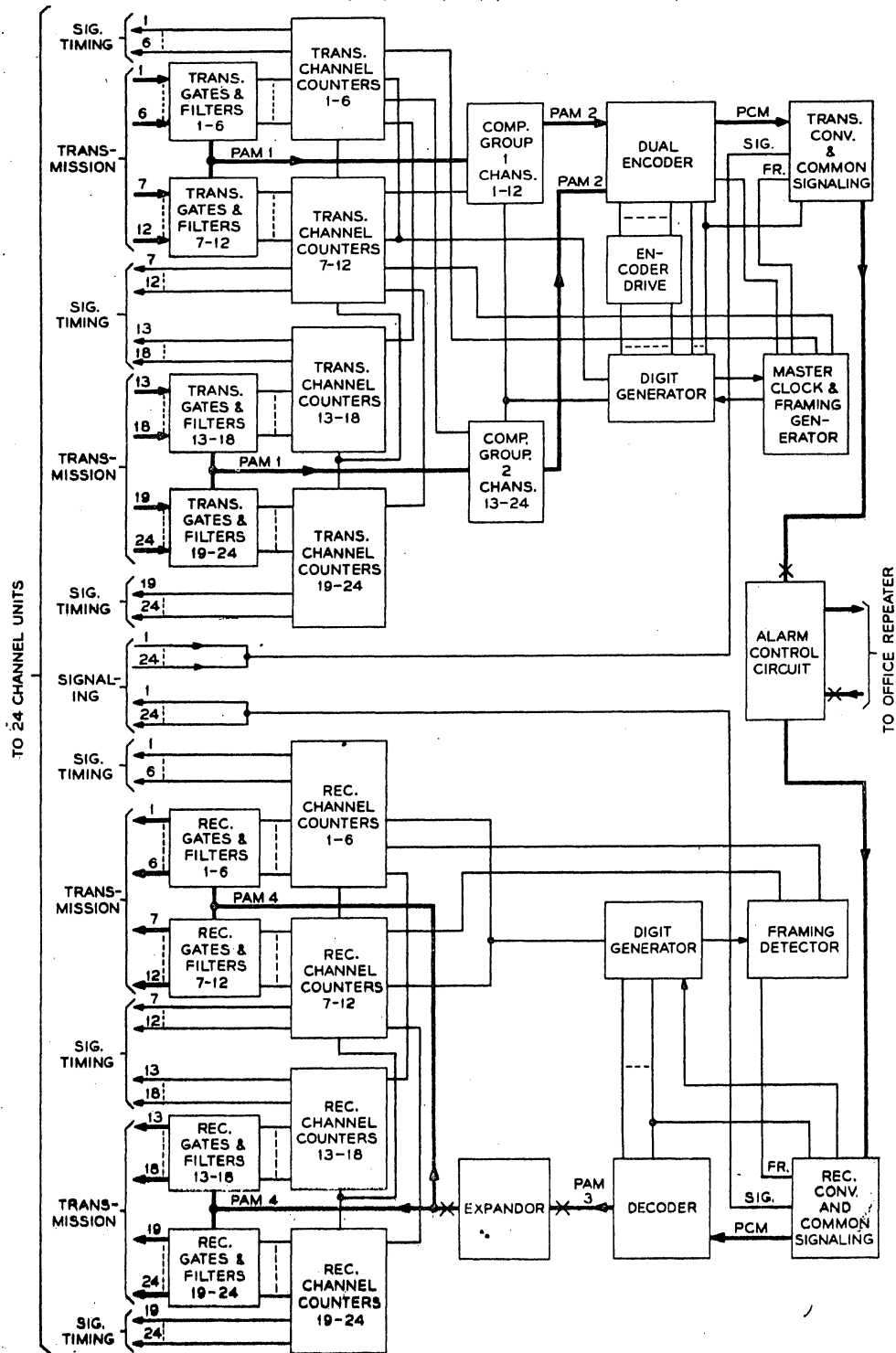

Figure 16-5 - D1 Bank Group Circuits Of Terminal

CHAPTER 16 PULSE CODE MODULATION AND T1 CARRIER

the pulse position is left blank. This gives the framing pulse a unique behavior that is not duplicated by any other pulse position on a steady state basis. When the system is out of frame, as indicated by a number of departures from the normal framing pulse pattern, it hunts through the pulse positions looking for one with the desired behavior. After the framing pulse position has been found, the systems locks on.

An alarm indicating the absence of synchronism between the terminals for a period of more than about 3 seconds will be provided. This alarm monitors the over-all performance of the system and indicates most catastrophic failures in the common equipment and the repeatered line. It provides an indication of system performance similar to the received carrier failure alarm in type N carrier. This alarm checks most of the digital control circuitry. It does not check the performance of the compressor, encoder, decoder, expander, or individual channel equipment.

No equipment will be provided in the T1 carrier terminal for ensuring disconnect of existing calls or preventing attempts to originate new calls over the system during an alarm condition. However, the alarm circuit in the terminal may be used with the carrier group alarm circuit (J98613AH, SD-98084-01) now in development for type N1 carrier. Provision of the group alarm circuit will be an operating company option. It provides for disconnecting calls in process and prevents the origination of new calls over the carrier system.

16.10 REPEATERED LINES

The T1 carrier system will be designed to work on existing types of 19- and 22-gauge paper - or pulp-insulated, staggered twist, paired exchange cables. Short sections of 24- and 26-gauge cables may be used if the repeater spacings are reduced appropriately. The system will operate over these types of facilities for distances up to at least 25 miles. Two cable pairs are required, one for each direction of transmission. Initially, the system will be restricted to underground cables. It is expected, however, that added features for aerial cable may be made available.

The signal to be transmitted over the repeatered line consists of a train of pulses. The information in the signal is contained in whether or not a pulse is present in a particular pulse position. To reduce the effect of intersystem crosstalk, the particular pulse train selected for the T1 system uses bipolar pulses. Successive pulses, regardless of the number of intervening spaces, are of opposite polarity. However, the significance of a pulse in any particular pulse position is independent of its polarity. Therefore, it is possible to convert from a unipolar pulse train (all pulses of the same polarity) to a bipolar pulse train (successive pulses of opposite polarity) by inverting every other pulse and to return to a unipolar pulse train by full wave rectification.

CHAPTER 16 PULSE CODE MODULATION AND T1 CARRIER

Since the information is contained in the presence or absence of a pulse in a particular pulse position, the signal is capable of regeneration.

Regeneration consists of deciding whether or not a pulse is being received in a particular pulse position and, if one is, of sending out a completely new pulse. Deciding whether or not a pulse is being received entails two things: knowing when to make the decision, i. e., timing; and determining whether or not the received voltage exceeds a predetermined threshold. All of the repeaters in the T1 system are of the regenerative type.

Timing is accomplished by rectifying the incoming bipolar pulse train to obtain a unipolar pulse train with 1.544×10^6 pulse positions per second. This unipolar pulse train has a strong single-frequency component at 1.544 mc, which is at exactly the same frequency as the crystal oscillator in the transmitting terminal. This sine wave is used to mark the individual pulse positions.

The pulses are regenerated by blocking oscillators (separate blocking oscillators for the positive and negative pulses of the bipolar pulse train). The threshold level is established in these blocking oscillators. Both a received pulse above the threshold and a timing pulse from the timing circuit are required to trigger the blocking oscillator.

The nominal repeater spacing in the T1 Carrier System is 6000 feet using 22 gauge cable. It is expected that up to 25 PCM systems (each system accommodates 24 voice channels) can be operated with both directions of transmission in the same cable sheath by segregating the two directions of transmission to separate and preferably non-adjacent units within the cable. Where more than 25 systems are to be accommodated, the two directions of transmission must be placed in separate cable sheaths. One cable operation for installations involving fewer than 25 systems and two cable operation for large numbers of system are the two modes of transmission considered.

Repeaters will be plugged into 466A Apparatus Cases for manhole installations. A laboratory model of the apparatus case is shown in Fig. 16-5. The upper picture shows the cover in place, while the lower photograph shows the cover removed. The repeater retainer is hinged to facilitate removing the cover and for easier access to the wiring. This case will accommodate 25 repeaters.

Each repeater includes two regenerators using a common power supply. For one-cable service a 201A regenerative repeater serves the two directions of transmission of a single system. For two-cable service a 201B repeater serves one direction of transmission for two separate systems. The 466A Apparatus Case is spliced into a cable such that when it is equipped with 201A repeaters one-cable operation is obtained. Two-cable operation is obtained if it is equipped with 201B repeaters. A laboratory model of the repeater is shown in Figure 16-7.

CHAPTER 16 PULSE CODE MODULATION AND T1 CARRIER

The nominal 6000 foot repeater spacing corresponds to an H loading section. Any load coils as well as any bridged taps must be removed from the pairs to permit PCM transmission. After an Apparatus Case has been installed and the load coils have been removed from the line, plug-in load coils (180A1 Coil Cases) may be inserted in the Apparatus Case in lieu of 201 type regenerative repeaters. In this manner, pairs not required immediately for T1 use may still be operated for voice use.

While the nominal repeater spacing is 6000 feet, variations are to be expected. In particular, it is necessary to locate repeaters adjacent to central offices nominally 3000 feet from the office in order to mitigate the effects of impulse noise. A series of buildout networks for the repeaters is provided to build out a given line to the equivalent of 6000 ± 250 feet of 22 gauge cable. These buildout networks which are inserted in repeaters are coded 826A to 863M.

Manhole repeaters and office repeaters in two cable systems are to be powered over the cable. A constant current is fed over the phantom of the E-W and W-E circuits, and the voltage at each repeater is obtained across a series of voltage regulator diodes. The repeater is designed to operate at about 10.5 volts and a line current of about 140 ma. The +130V, -130V, and -48V office batteries are used as power sources. (Refer to Section 14.53) The repeaters are designed to permit either a through power connection or a loop power connection. Thus battery can be supplied at either or both ends of a repeatered line. It is expected that 18 repeaters can be powered by using both +130V and -130V at each end of a line.

Complements of cable pairs between appropriate main frames will be assigned to the T1 carrier and spliced into repeater cabinets. A particular system may be made up of repeatered lines from a number of different complements. For ease in line-up and maintenance and flexibility in assignment of repeatered lines to systems, the repeatered lines between two main frames will be administered as a block. Since repeaters will generally be located in the building whenever the cable pairs terminate on the main frame, all of the repeatered lines along a particular route go from one office repeater location to another. The block of repeatered lines between two office repeater bay locations is known as a repeatered line span (see Figure 16-8). A standard level point (the level of a repeater output) is established at the office repeater panels at the ends of the span. All of the repeatered lines in a span are similar and may be used interchangeably. Terminals will be connected to repeatered lines at the office repeater locations.

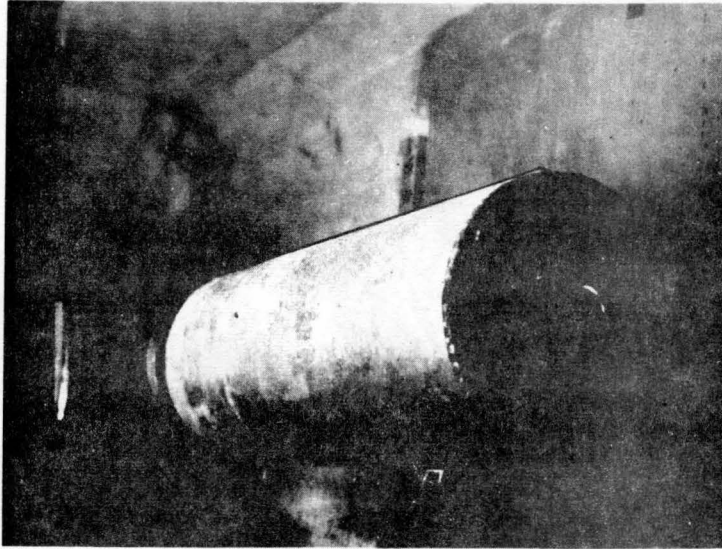

Experimental Model of 466A Apparatus
Case Installed in a Manhole

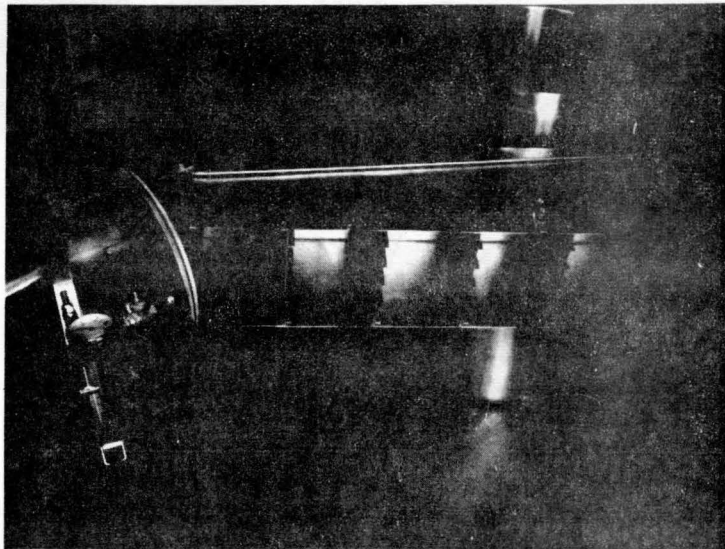

Experimental Model of 466A Apparatus
Case With Cover Removed. Retainer
shown moved forward on its hinge.

Fig. 16-6

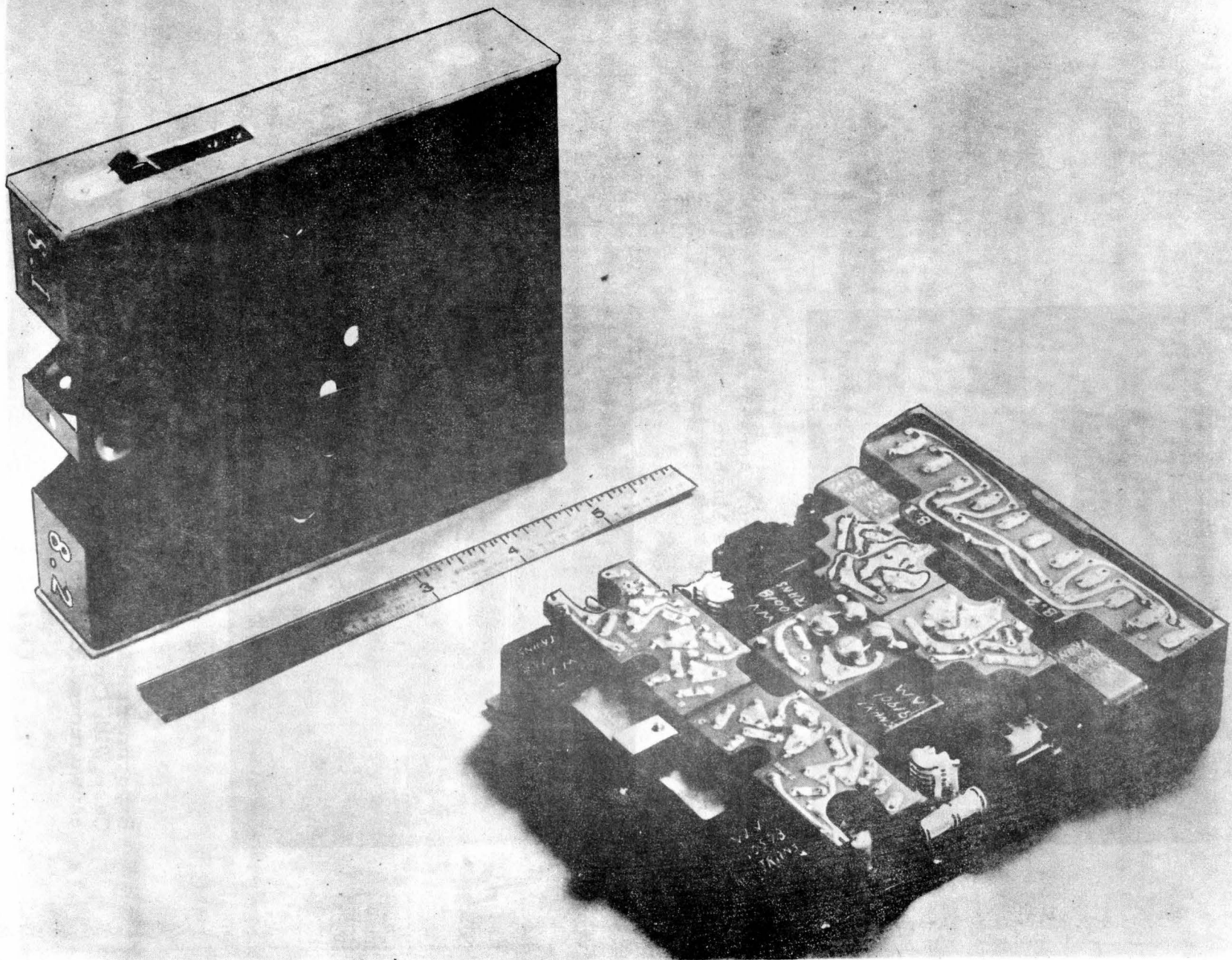

16.16

Figure 16-7 201 Type Repeater - Laboratory Model

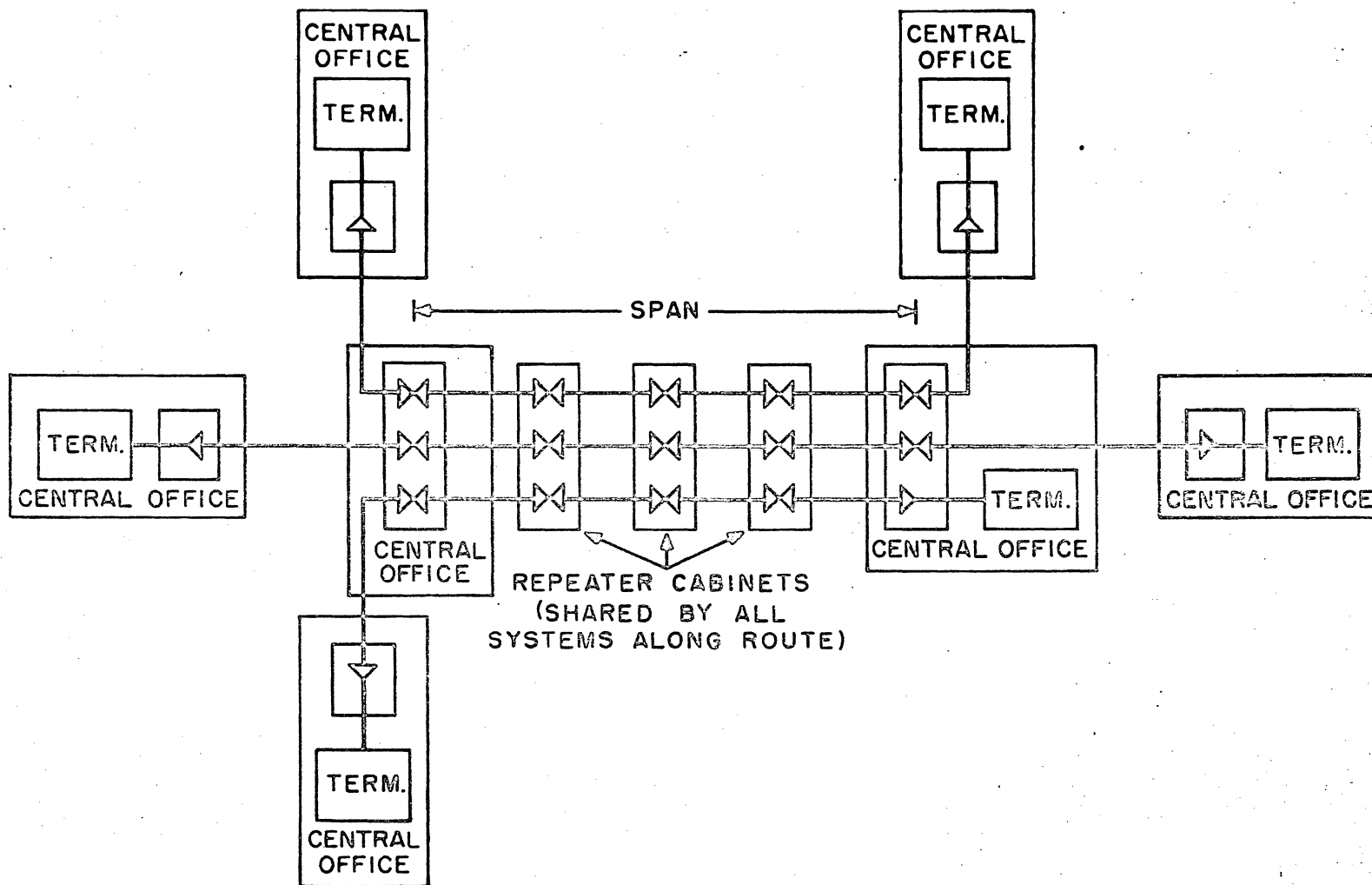

16, 17

Span Concept

Figure 16-8

CHAPTER 16 PULSE CODE MODULATION AND T1 CARRIER

16.11 EQUIPMENT ARRANGEMENTS

In order to achieve the economies of "office engineering", as much of the terminal equipment as practical will be constructed as plug-in packages or as easily demountable units which mount in a bay framework. The office engineering concept entails installing more basic bays and their associated office cabling than are needed immediately, rather than providing frequent additions. Making less frequent large installations reduces the number of times that the office records must be changed and makes more efficient use of installers. Plug-in equipment lends itself readily to office engineering, because the basic bays and cabling can be installed in advance and the costly plug-in units added as needed by operating company personnel.

For further economy in installation, the bay framework will be shop-wired. The shop-wired bay will be equipped with the shelves and sockets for the plug-in packages and all of the intrabay wiring. All field connections to the terminal bay to be made during installation will be made at a terminal block located at the top of the bay.

The initial design of the shop-wired terminal bay shown in Figure 16-4 mountings for three system terminals (72 channel terminals) and their associated power supplies. It will be 11 feet 6 inches high and nominally 23 inches wide. Additional bay arrangements, such as a shorter bay for use in buildings that will not accommodate 11 foot 6 inch bays, will probably be required eventually. However, they are not being provided in the initial design.

A system terminal will consist of 24 channel units and 29 common equipment units. The channel units contain the signaling converters and either per channel amplification or a 4-wire terminating set as required. Five types of channel units will be provided initially. They are:

1. Channel unit with 4-wire terminating set accepting outgoing dial pulse signaling.
2. Channel unit with 4-wire terminating set providing incoming dial pulse signaling.
3. Channel unit with 4-wire terminating set accepting outgoing revertive pulse signaling.
4. Channel unit with 4-wire terminating set providing incoming revertive pulse signaling.
5. Channel unit with E&M lead signaling.

CHAPTER 16 PULSE CODE MODULATION AND T1 CARRIER

Those channel units with built-in 4-wire terminating sets are being designed to provide a switch-to-switch net loss of 2.0 ± 0.5 db. The loss between the 2-wire input to the 4-wire terminating set and the 2-wire output of the terminating set at the distant terminal will be about 0.5 db. The office loss between the switches and the input to the 4-wire terminating set will be built out to 0.75 ± 0.25 db at each end. This will be accomplished by adding 0.5 db of loss whenever the office loss is less than 0.5 db. Provision for adding this 0.5 db of loss is being incorporated in the intra-bay wiring of the T1 terminal. These padding arrangements have been chosen to give an economical balance among minimizing clipping of loud talkers, minimizing noise in the absence of signal, and maintaining low net loss.

A 2-db pad will also be included in these channel units which may be inserted in the receiving 4-wire branch on an optional basis. This pad may be used to increase a 2 ± 0.5 db net-loss trunk to 4 ± 0.5 db net-loss. These arrangements are shown in Figure 16-9.

The channel unit with E&M lead signaling will not include a 4-wire terminating set. It will terminate 4-wire at 600 ohms with standard VF patching levels (-16 db transmitting and +7 db receiving). Voice frequency amplification within the channel unit will be required to produce these levels.

Circuit opening test jacks will be included in all channel units. They will be located in the 4-wire circuit, and all of the active elements in a voice channel will be included between the input and output jacks, except for the voice frequency amplification in the channel unit with E&M lead signaling. The jacks will be at -9.5 db transmitting and +3.0 db receiving system level points and will have an impedance of 2,500 ohms unbalanced.

Additional channel units may be developed at a later date as demand develops.

The common equipment includes the compressor, encoder, decoder, expander, common amplifier, and the digital control circuits. The sampling and demultiplex gates with their associated filters are also considered part of the common equipment, because it is desirable to concentrate these circuits into a few packages located physically close to the remainder of the common equipment in order to reduce lead length. Therefore, the common equipment alone provides 24 complete 4-wire voice channels. The channel units serve only as the matching units between these channels and the external trunk circuitry.

The common equipment is divided into a number of packages for ease in manufacture and maintenance.

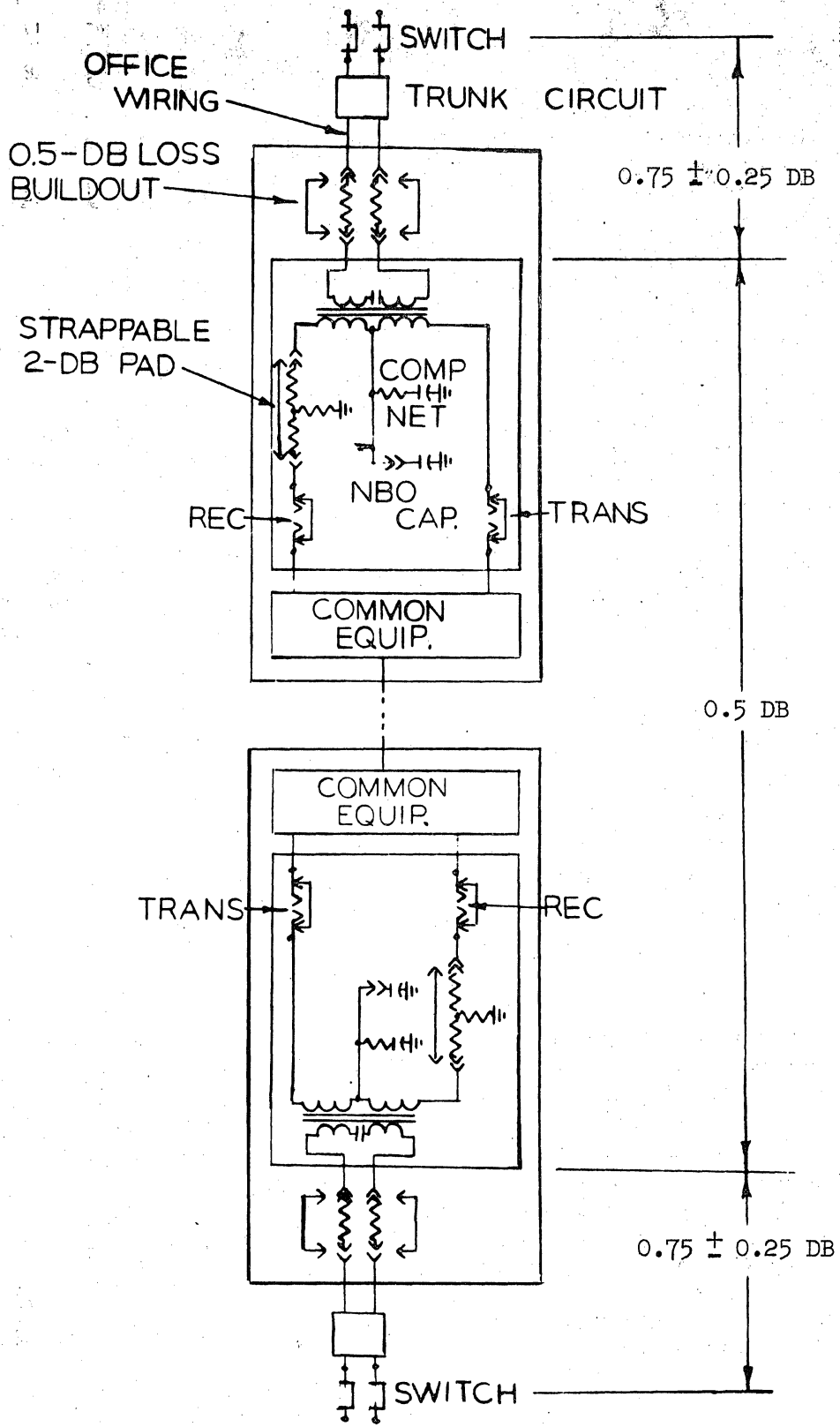

Pad Arrangement
Figure 16-9

CHAPTER 16 PULSE CODE MODULATION AND T1 CARRIER

The terminals will be powered from the -48 volt office battery as described in Section 16.12. The power dissipation in a fully equipped terminal bay will be approximately 650 watts. The different voltages required by the terminal equipment will be obtained with dc-to-dc converters located near the top of the shop-wired bay.

The dc-to-dc converters and associated regulators will be arranged for additional to the bay by local telephone company personnel, after the basic bay has been installed.

16.12 REPEATERS

Initially a repeater cabinet will be provided that is capable of holding 25 repeaters, a fault locating filter and order wire terminals. This cabinet is shown in Figure 16-6.

The cabinets are made of hot-dip galvanized steel to provide adequate service life in manhole environments. They are supplied with a 22-gauge PVC insulated lead sheathed cable stub for splicing into the main cable.

With few exceptions the cables that will be utilized for T1 carrier systems will be pressurized; therefore, the cabinet is provided with the necessary gas plugs, valves, and bypasses to keep it under pressure when closed, and to release the pressure without losing cable pressure when it is to be opened.

Connections to a repeater are made by female connectors on the repeater and male plugs in the cabinet. These plugs are mounted on a false bottom with the cable conductors fanned out to them in the chamber beneath. To permit repair of this wiring or the plugs without removing all repeaters, the bottom of the cabinet is removable.

The order wire terminals are accessible without opening the repeater cabinet. An order wire will be provided for communication between repeater locations or between any repeater location within a span and the two buildings at the ends of the span. This order wire will be voice-frequency loaded and all the repeater cabinets in a span will be bridged onto the same order wire pair.

The repeaters in each cabinet will be connected to the fault locating filter which, in turn, will be bridged to a fault locating pair in the cable. On fault locating pair will be required for each 25 systems along a route. The fault locating system will be used to determine repeater cabinets containing a defective repeater by tests made at the ends of the repeated line.

As discussed previously, there will be repeaters located in central office buildings at the two terminal offices and at appropriate intermediate central

CHAPTER 16 PULSE CODE MODULATION AND T1 CARRIER

offices. These repeaters will mount in central office repeater assemblies. Two equipment assemblies will be provided:

1. Span terminating assembly.
2. System terminating assembly.

The span terminating assembly shown in Figure 16-10 terminates span lines entering the building from other offices. It mounts on a 23-inch bay, is 10-1/2 inches high, and provides power feed, test jacks, and incoming repeaters for 12 span lines. Cross-connect facilities are provided as part of the unit so that span lines may be interconnected as desired. These span terminating assemblies will be connected to the horizontal on the main frame by individually shielded pairs or by lead sheath cables with separate sheaths for repeater inputs and outputs. Shielded jumpers will be required on the main frame.

A system terminating assembly shown in Figure 16-11 is used only when terminals are located in the same building. The terminals will be connected to the system terminating assembly by individually shielded pairs. It mounts on a 23-inch bay, is 5-1/4 inches high, and provides test jacks and equalizers for 12 system terminals (four terminal bays). The line repeaters are powered over the pairs used for pulse transmission. They are powered in a series string with the power being applied at the span terminating office repeater assembly. The primary source of power for the repeated lines will be the appropriate combination of -48 volts only, +130 volts only, +130 volts and -48 volts, or +130 volts and -130 volts. A particular span may be powered from both ends. Positive 48 volts, -42 volts, +24 volts and -24 volts are obtained from 48-volts central office battery using ac to dc transistor converters and series transistor regulators. The preferred combinations of battery voltages for 22-gauge cable are given in Table 2. The span lengths for the same voltages will be somewhat longer for 19-gauge cable.

BATTERY VOLTAGES PREFERRED

Span Length	Office A	Office B
miles	volts	
0 to 2	- 48	no power
2 to 4	- 48	- 48
4 to 6	+130	no power
6 to 8	+130 and - 48	no power
8 to 10	+130 and - 48	- 48
10 to 13	+130 and - 48	+130
13 to 15	+130 and - 48	+130 and - 48
15 to 17	+130 and -130	+130
17 to 19	+130 and -130	+130 and - 48
19 to 22	+130 and -130	+130 and -130

TABLE 2

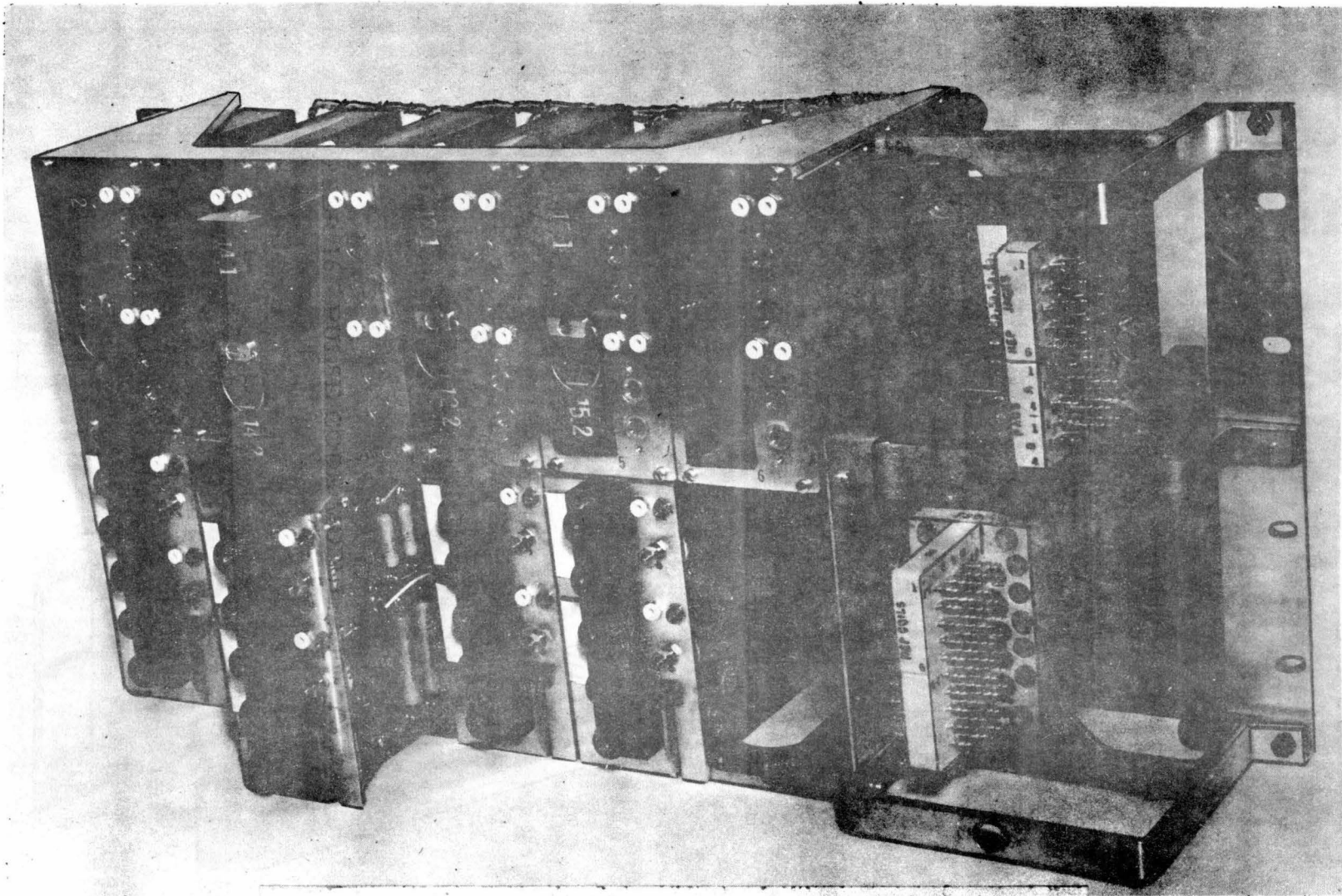

Span Terminating Assembly for T1 Carrier Trial
(front view)
Figure 16-10

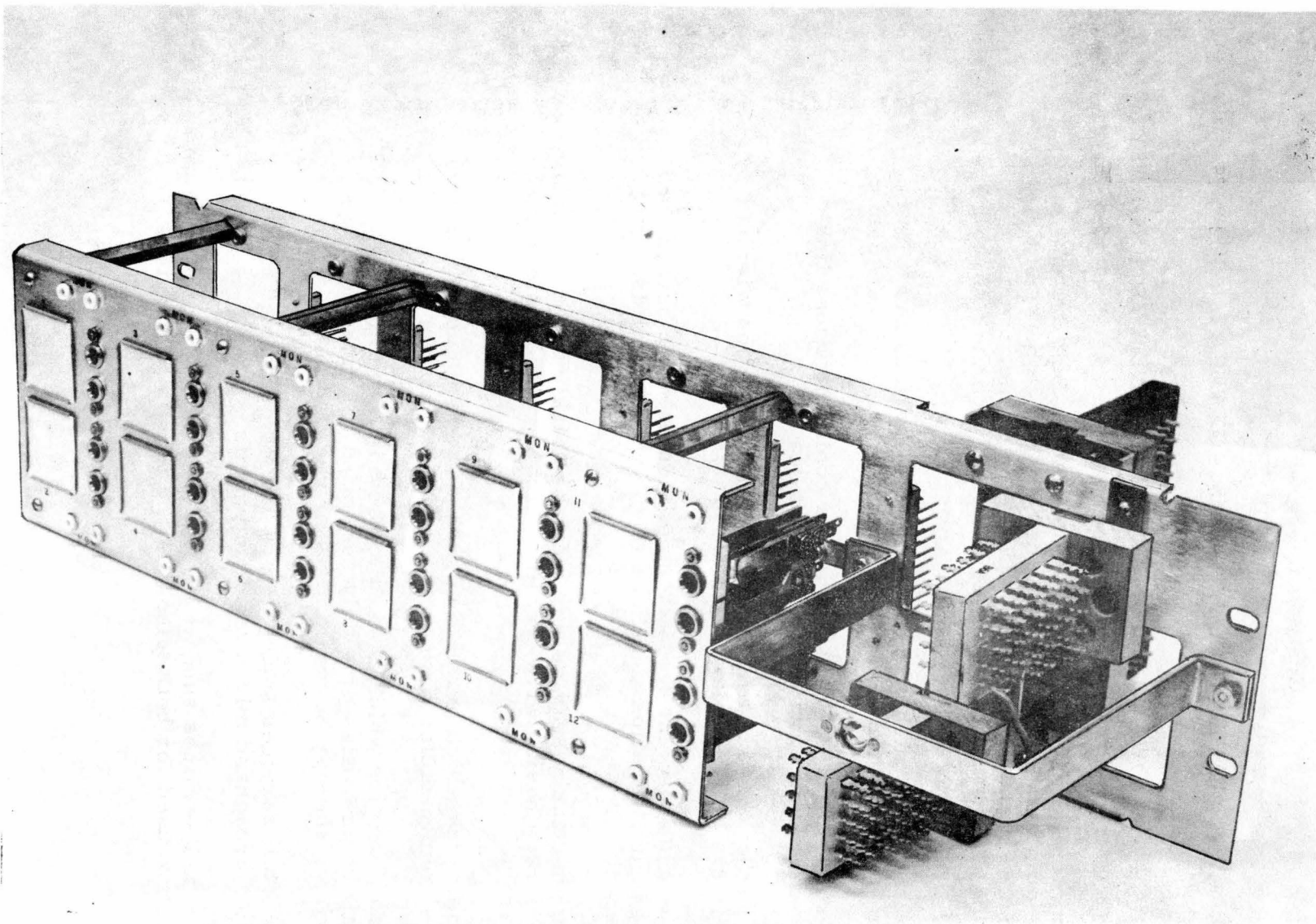

Bank Terminating Assembly for T1 Carrier Trial
Figure 16-11

CHAPTER 17

MICROWAVE RADIO SYSTEMS - GENERAL

17.1 GENERAL MICROWAVE RADIO CONCEPTS AND TERMINOLOGY

Introduction

The first commercial use of radio was made by the Bell System in July 1920 when a radiotelephone link was placed in service between Catalina Island and the mainland of California. Since that time, the use of radio has grown to include many types of services of which the following are illustrative:

- a. Overseas service which provides a communications link with the communications systems of most of the countries of the world.
- b. Ship-to-shore service which provides a communications link with trans-oceanic liners and cruise ships at sea.
- c. Coastal harbor service which permits communication with nearby vessels in coastal and inland waterways.
- d. Domestic point-to-point service sometimes used for bridging difficult geographic situations, such as the Tangier-Smith Island circuits in Chesapeake Bay.
- e. Portable emergency service which can be quickly set up to replace, on a temporary basis, wire circuits which have been interrupted by the elements.
- f. Mobile services which permit interconnection with normal telephone facilities from vehicles such as automobiles or trains.
- g. Rural radio service which is used to provide a communication link into small communities or widely separated customer locations where wire plant may be impractical or uneconomical.
- h. Short haul toll services such as "pick-up" or "side leg" television links using broadband microwave equipments.
- i. Long haul toll services such as the coast-to-coast microwave radio relay system used for both telephone and television services.

CHAPTER 17 MICROWAVE RADIO SYSTEMS - GENERAL

The fact that radio waves do not require a physical transmission path, such as the cable or open wire used for lower frequency alternating currents, has brought about their use in the Bell System for the many services as indicated above. While early radio transmission utilized carrier frequencies in the order of 60,000 cycles per second (60 kilocycles per second or 60 kc), advances in equipment and techniques have now made possible operation with frequencies as high as thousands of megacycles (1 megacycle equals one million cycles). It is this region of thousands of megacycles that has been defined as "microwave" and is now expressed as kmc ("k" for thousands and "mc" for megacycles). Microwave frequencies currently used for communications purposes are in the range having a wave length of three to seven or eight centimeters.

The reasons for the trend toward the use of higher frequencies are manifold. There are a number of propagation factors, which will be discussed later, that favor the use of microwaves. The rapid adoption of radio communication by others than the Bell System has resulted in a highly competitive demand for channel space in the lower frequency spectrum. In order that each type of service, such as common carrier, military, etc., may have its fair share of the radio spectrum, the individual frequency allotment must, of necessity, be limited. This has forced a continual emigration to higher and higher frequencies in order to achieve the necessary number of communication channels with adequate bandwidth. The bandwidth required for a given communication channel is proportional to the rate at which a given portion of intelligence is to be transmitted. As a result, intelligence transmitted at a slow rate, such as hand telegraph signals, may require a facility to transmit a group of frequencies of 50 or 100 cycles; whereas television, which must convey an entire scene almost instantaneously, will require a bandwidth of several megacycles. It can, therefore, be seen that the number of communication channels which can be provided in a given portion of radio spectrum is governed by the type of intelligence which must be transmitted.

Some idea of the use of the radio spectrum by the Bell System over the last 40 years can be gained from an examination of Table 17-1. The first column indicates some of the desirable characteristics of a communication channel, while the second column indicates the way in which a radio circuit should meet those requirements in order to approach wire line performance. The first characteristic, "directivity," relates essentially to the requirement for secrecy of communication; the second characteristic, "noise," is related to intelligibility; "transmission disturbances," are obviously related to reliability; while, "frequency space available," relates to the number of communication channels possible for any given bandwidth requirement.

CHAPTER 17 MICROWAVE RADIO SYSTEMS - GENERAL

17.2 RADIO TRANSMISSION CHARACTERISTICS ABOVE 30 MEGACYCLES

General

In the early 1940's, frequencies in the 30 to 40 megacycle band were used for short haul communication services, such as local or state police and forestry circuits. The television and FM broadcasting industry were proposing the use of somewhat higher frequencies, while research organizations were studying the transmission properties of radio waves at frequencies in the thousand or more megacycle range. During World War II both the military and the civil need for more short distance radio channels caused great strides to be made in the application of frequencies up to 300 megacycles. Wartime development of techniques and equipment for radar use resulted in the utilization of frequencies in the ranges of 4,000 to 10,000 megacycles. Sufficient information was obtained relative to the propagation of frequencies in this region so that consideration was ultimately given to the use of the microwave frequencies for communication uses. The initial Bell System application of microwave for communication purposes was in the 4,000 megacycle range. Some of the transmission characteristics of radio waves in the spectrum above 30 megacycles can be compared by reference to Figure 17-1, which attempts to give a brief pictorial presentation. The pictorial presentation is amplified to some extent under the Notes in the right hand column.

Ionospheric (Sky) Reflection

As the frequency of transmission is increased, reflection of the so-called sky wave by the ionosphere is either of such an angle that it misses the earth's surface or disappears entirely, as illustrated in Part A of Figure 17-1. Thus, at the higher frequencies transmission is limited to the direct or ground wave of propagation. As indicated in Figure 17-1, little interference between systems operating at the same frequency, hundreds of miles apart, should be expected from ionospheric reflection of the sky wave for frequencies above about 100 megacycles. This characteristic recommends the use of the higher frequencies (above 100 megacycles) for short haul service, since the same frequency spectrum allotment may be used at several different geographic locations.

Shadowing by Earth's Curvature and Other Obstacles

As indicated in Figure 17-1, the earth, due to its curvature, will intercept the direct wave of radio transmission at a distance from the transmitter. This distance is a function of the actual curvature of the earth, the surface configuration at that point and the antenna height. This point of intersection can be described as the radio horizon. With an increase of frequency, less and less signal energy will be received. With currently used transmitter powers, essentially no signal is received beyond the horizon, except in certain extreme cases of propagation which will be mentioned later. It will be noted that the shadowing effect of the earth's

		1915	Early 1920's	Late 1920's	1930's	1940's	1950's
		Transatlantic Radio-Telephone Demonstration	Ship-Shore Experiments Broadcasting	Transoceanic Service	FM Television Virginia Capes Multiplex	Radio Relay	Over-The-Horizon
Ideal Requirements for Wire Type Performance		5000 Meters (60KC)	500-200 Meters (0.6-1.5MC)	60-15 Meters (5-20MC)	7-2 Meters (40-150MC)	15-2.5 Centimeters (2,000-12,000MC)	?
Directivity	Sharp	None	None	Some	Moderate	Sharp	Limited
Noise	Low and Steady	Severe Static Variable	High Static Variable	Moderate Static. Man-Made Interference Important	Low Static. Man-Made Interference Serious	Low - Mostly Originates in Receiver Components and Controlled by Design	
Transmission Disturbances	Small and Slow	Small	Marked Rapid	Severe Rapid	Echoes Troublesome for Television	Slow but Occasional Deep Fades	Small
Frequency Space Available	Unlimited	Very Small	Meagre	Small	Moderate (Crowded)	Large	?

Table 17-1 The Trend of Radio Performance Characteristics

TRANSMISSION EFFECT	30-300 MC	300-1,000 MC	1,000-10,000 MC	ABOVE 10,000 MC	NOTES
A REFLECTION FROM IONOSPHERE					AT THE HIGHER FREQUENCIES, THERE ARE BELIEVED TO BE NO REFLECTIONS FROM THE IONOSPHERE - A REGION EXTENDING APPROXIMATELY FROM 50 TO 400 MI. ABOVE THE EARTH'S SURFACE.
B SHADOWING BY EARTH USUAL WEATHER CONDITIONS FAVORABLE WEATHER CONDITIONS ANOMALOUS PROPAGATION - DUCTS UNFAVORABLE WEATHER CONDITIONS ATMOSPHERIC REFRACTION					UNDER USUAL WEATHER CONDITIONS, THE BULGE OF THE EARTH'S SURFACE CASTS RADIO "SHADOWS" WHICH DEEPEN AS THE FREQUENCY IS INCREASED; AND RECEPTION AT POINTS BELOW LINE-OF-SIGHT BECOMES PROGRESSIVELY MORE DIFFICULT.
					AT TIMES, THE EARTH'S ATMOSPHERE MAY BEND THE RADIO WAVES IN SUCH A MANNER THAT THEY FOLLOW APPROXIMATELY THE EARTH'S CURVATURE IN WHAT MAY BE CALLED "DUCTS"; AND, EVEN AT THE HIGHEST FREQUENCIES, RECEPTION IS POSSIBLE AT POINTS BELOW LINE-OF-SIGHT.
					AT OTHER TIMES, THE EARTH'S ATMOSPHERE MAY BEND THE RADIO WAVES IN SUCH A MANNER THAT, EVEN AT POINTS ABOVE LINE-OF-SIGHT, RECEPTION BECOMES PROGRESSIVELY MORE DIFFICULT AS THE FREQUENCY IS INCREASED.
C SHADOWING BY OBSTACLES					HILLS AND BUILDINGS CAST RADIO "SHADOWS" WHICH DEEPEN AS THE FREQUENCY IS INCREASED.
	D LOCAL REFLECTION REFLECTION FROM NEARBY OBJECTS FLUTTER				
E NOISE LIMITATIONS					MAN-MADE RADIO FREQUENCY NOISE (ENGINE IGNITION, DIATHERMY MACHINES, ETC.) DECREASES EVENTUALLY IN THE UPPER FREQUENCY RANGES WHILE RADIO SET NOISE (THERMAL) INCREASES SOMEWHAT.
F ANTENNA HEIGHT vs POWER GAIN					THE STRENGTH OF THE RECEIVED FIELD AT FIRST INCREASES WITH ANTENNA HEIGHT. ON OPTICAL PATHS, DIRECT AND EARTH-REFLECTED WAVES COMBINE TO FORM AN INTERFERENCE PATTERN; BUT, AT THE HIGHEST FREQUENCIES, SCATTERING REPLACES EARTH REFLECTION.
G ABSORPTION					DENSE FOLIAGE IN THE TRANSMITTING PATH ABSORBS MORE AND MORE OF THE RADIO WAVES AS THE FREQUENCY IS INCREASED; AND, IN THE HIGHEST FREQUENCY RANGE, ABSORPTION AND SCATTERING BECOME COMPLETE.

Fig. 17-1 Radio Transmission Effects With Relation to Frequency

CHAPTER 17 MICROWAVE RADIO SYSTEMS - GENERAL

surface at the horizon is similar to the effect produced with light waves, and in general it is found that microwaves behave in essentially the same manner as light waves. As a result, it is possible to estimate microwave transmission range, optically, on the basis of line of sight.

As with light, the shadow effect upon microwaves is not complete and experiments in long range transmission are now being conducted to determine the feasibility of "over the horizon" transmission by using transmitters with very high output. A small amount of random energy will permeate the shadow region. By using very sensitive receivers, it is anticipated that communication can be established at distances well beyond the horizon. Since the received energy will be of a highly scattered character, it is not anticipated that fading and other impairments to be discussed in the following paragraphs will be detrimental to over-the-horizon transmission. At the time of writing, data is not available as to the effectiveness of this type of operation.

At the lower frequencies, such as the range between 30 and 300 megacycles, shadowing due to the earth's curvature is not so serious a problem, and FM broadcasts have been regularly received over distances of 200 miles or more using a 50 kilowatt transmitter operating on a frequency of 45 megacycles.

Under certain weather conditions the line of sight range may be modified by bending of the radio wave path. Sometimes the bending may be in such a direction as to cause the radio waves to leave the earth's surface, while at other times it may be in such a direction as to cause the radio waves to more nearly follow the earth's surface. While not too well understood, this phenomena is comparable to the bending of light waves. This can be illustrated by the effect that is sometimes noticed when a stick is placed partially in water and appears to be bent at the surface of the water. This bending effect is most noticeable at the super high frequencies.

We have discussed the shadowing effect resulting from the earth's curvature and have established a radio wave horizon. It should be pointed out, however, that other objects, particularly in the microwave region, may also produce the shadow effect. A mountain, large buildings or even a mass of trees inserted in a microwave path may result in a major reduction in received signal due to this effect which is pictorially illustrated in Part C of Figure 17-1. The pictorial representation indicates why the lower frequencies, such as in the 40 megacycle region, are preferable for mobile use, since it is not possible to continually operate a vehicle in a location where hills or buildings will not at some time intercept the path from the vehicle to the base station. The pictorial representation also indicates one of the reasons why microwave stations are generally located on high points in order to have a clear line of sight path to the next station.

CHAPTER 17 MICROWAVE RADIO SYSTEMS - GENERAL

Reflections

We know that light waves are not only intercepted by intervening objects to produce shadows, but also reflected. In the same fashion, we find that radio waves may also be reflected by objects in or near the transmission path. As a result, the transmitted signal may reach a receiver over one or more paths, which will require different amounts of transmission time due to their length, and have different attenuation characteristics. Depending upon the relative signal strength and time of arrival, these multiple path signals may either add or cancel to produce a stronger or weaker signal than that which might have been obtained over the direct path along. By examining the pictorial presentation in Part D of Figure 17-1, it can be seen that as either the transmitter or receiver location is moved the direct and reflected path lengths will be changed. As a result the transmitter and receiver locations may be selected to take advantage of the effective gain resulting from the addition of the signals over the multiple paths. In the case of mobile reception, it is obviously impossible to confine the vehicle to a specific geographic location, and as a result it may pass through alternate areas of strong and weak signal caused by the addition or cancellation resulting from multiple path reception. This results in a very noticeable flutter in the output of the receiver that can become very objectionable, depending upon the local terrain and the speed of the vehicle. As the frequency is increased, this flutter effect may result in the loss of entire syllables of speech or may result in a form of objectionable noise, interspersed with the speech. In open country where clear line of sight paths may be obtained, the effect is less objectionable.

Noise Considerations

At the low frequencies in the order of 30 megacycles or so, atmospheric noise may become very objectionable and, at times, may make a radio circuit unintelligible. This is the familiar static type of noise often heard with broadcast radio during severe electrical disturbances, such as thunder storms. As the frequency of transmission is increased above 30 megacycles, the atmospheric noise effect diminishes, since there are few noise components in this frequency region. However, man-made noises may still be very objectionable. The making or breaking of electrical circuits by devices such as heater thermostats or thermostats associated with home aquariums or similar devices generally produce a spark. This type of spark, as well as the spark plug discharge in the ignition systems of gasoline engines, contains frequencies over a very wide range of the radio frequency spectrum. These frequencies are readily radiated over portions of the wiring associated with the device, causing radio interference. The radiated energy from frequency components of this type diminishes very rapidly above 300 megacycles and is essentially negligible above 1 kmc. It would thus appear that interference from noise would be a minor consideration when operating at the higher microwave frequencies. Unfortunately, this is not the case. Above 1 kmc we find that noise generated in the receiver circuit elements becomes of major importance and

it is this noise which effectively establishes the length of the transmission path, since the path must be short enough to provide a received signal that will override the inherent receiver noise. We find at microwave frequencies that minute variations in plate current of vacuum tubes, called shot effect, and noise due to thermal agitation of the electrons in wiring and resistors and similar types of noise originating in the grid circuits of vacuum tubes occurs at frequencies comparable to the received signal. This type of circuit noise originating in the front end (or low level portions) of radio receivers will be amplified by the same amount as the incoming signal and will appear in the receiver as background noise of a hissing or rushing character. This type of noise can only be corrected by improved circuit design, refinements in the technique of vacuum tube manufacture or by some other method which will maintain a high signal level with respect to the noise level. This relationship is often referred to as the signal to noise ratio.

Effect of Antenna Height

By bearing in mind that microwaves behave in essentially the same manner as light waves, it can be seen from an examination of Parts B and C of Figure 17-1 that increasing the height of the antenna at the receiver or transmitter will increase the range of transmission. However, this increase in range is limited by the economics of providing the supporting structure for the antennas. Shadowing by the earth's curvature or by intervening obstacles is not the only factor, however, in considering the height of an antenna above ground. By referring to the pictorial presentation in Part F of Figure 17-1, it will be noted that below 10 kmc the received signal intensity varies in a regular manner with antenna height. This pattern is produced by reflection of the radio waves from the earth's surface in the same manner as previously discussed for intervening objects. As the antenna is raised or lowered at either the transmitting or receiving end, the energy reflected from the earth's surface will combine with the energy along the direct transmission path in such a manner as to increase or diminish the effect of the received signal. In some types of terrain, this addition or cancellation due to reflection from the earth's surface becomes a serious problem. In some types of level terrain, such as desert areas, the reflective plane of the earth's surface may vary during certain periods of the day resulting, at times, in almost complete cancellation of the received signal or what is known as a deep fade. To counteract this effect, antenna heights are frequently staggered with one antenna on a very high tower and the next antenna on a low platform close to the earth's surface. With the highly directive antenna systems used, it is possible to avoid the reception of the reflected wave and thus reduce the cancelling effect and so minimize the fading condition.

CHAPTER 17 MICROWAVE RADIO SYSTEMS - GENERAL

Antenna Directivity

If a small flashlight bulb could be constructed without a base and energized by very thin wires from a remote power source, it would radiate light in all directions. If a small square of cardboard were placed a few feet away from this bulb, it would be illuminated by a portion of the light produced by the bulb. However, it is apparent that only a small amount of the light generated would fall on this particular piece of cardboard. A simple radio antenna likewise radiates radio waves in all directions and consequently a receiving antenna at some distance can intercept only a small percentage of the total amount of energy radiated. If now an optical reflector, such as that used in a flashlight or searchlight, is placed in back of the special bulb mentioned above, much of the stray light can be redirected by means of this reflector and the illumination received by the small piece of cardboard will have been materially increased. In the same way, reflecting devices may be associated with a radio antenna so that the energy can be transmitted in a direction where it may be intercepted by the receiving antenna. Again referring to the special lamp bulb, it is possible to place an optical lens in such a position that much of the light radiated in the general direction of the piece of cardboard can be collected and focussed to fall upon the piece of cardboard. Thus by means of properly designed reflector and lens combinations, almost the entire light output of the bulb can be concentrated on the small area of cardboard and it will be much more brightly illuminated than when it received only its small proportion of the light that was radiated in all directions. In the same fashion, it is possible to produce electrical lenses which will function in much the same manner to collect and concentrate the radio waves and direct them toward the receiving antenna. By redirecting and concentrating the radiation from an antenna to concentrate it on a receiving antenna, an increase in signal level can be obtained equivalent to an increase in transmitter power of several million times, had a non-directional antenna been used. This increase in received level resulting from the directing of the antenna radiation is referred to as antenna gain and is the ratio of energy actually received to that which would have been received from a non-directional antenna at the same location. It should be noted that antenna gain does not signify an increase in energy but rather a better utilization of the available energy. In addition to the better utilization of the available transmitter power output, directive antenna arrays also provide a greater degree of privacy and reduce the probability of interference to receivers other than the one toward which the transmission was directed.

17.3 F.C.C. CLASSIFICATION OF THE FREQUENCY SPECTRUM

In the early days of radio when transmission was by means of damped wave trains, such as produced by spark gaps, the operating frequency was determined pretty much by equipment limitations. With the advent of high frequency rotary generators and the later development of the vacuum tube,

CHAPTER 17 MICROWAVE RADIO SYSTEMS - GENERAL

it became possible to operate radio stations on a single specified frequency. This meant that a greater number of stations could operate simultaneously without interference to each other. During this period, operation was confined to frequencies with wave lengths over 200 meters. With refinements in the manufacture of vacuum tubes, it ultimately became possible to operate radio systems at frequencies having wave lengths considerably less than 200 meters. To differentiate between this type of operation and the rotary generator operation, the terminology of "long wave" and "short wave" radio arose. As expansion of the radio spectrum continued and frequencies of operation became higher and higher with the corresponding shorter and shorter wave lengths, the term short wave became meaningless. To clarify the situation somewhat, the Federal Communications Commission divided the radio spectrum into groups and assigned classifications to these groups which could be used to quickly identify the particular portion of the spectrum in which activity was being proposed. The spectrum classification which has been standardized by the F. C. C. is as follows:

<u>Frequency (mc)</u>	<u>Description</u>	<u>Abbreviation</u>
0.01 to 0.03	Very low frequency	VLF
0.03 to 0.3	Low frequency	LF
0.3 to 3.0	Medium frequency	MF
3.0 to 30	High frequency	HF
30 to 300	Very high frequency	VHF
300 to 3,000	Ultra high frequency	UHF
3,000 to 30,000	Super high frequency	SHF
30,000 to 300,000	Extremely high frequency	EHF

It will be apparent from an examination of the above tabulation that the frequencies commonly referred to as long wave correspond fairly closely with the LF designation, while the frequencies normally referred to as short wave correspond rather closely with the HF designation.

17.4 GENERAL RADIO RELAY CONSIDERATIONS

From about 1920 until the early 1940's, considerable research work had been done toward the development of vacuum tubes and equipment components that might be used at the microwave frequencies; but a practical application of these components had not been made in the Bell System communications network. During World War II, impetus was given to manufacturing techniques directed toward this type of equipment in order to develop more effective radar systems. By the end of World War II, sufficient proficiency had been gained in the manufacture of highly sensitive receivers, relatively efficient transmitters, and directive antenna arrays, to warrant a trial communications circuit in the 4,000 megacycle range. Prior to the use of microwave radio, the only available method of establishing broadband communications channels was by means of coaxial cable carrier systems.

CHAPTER 17 MICROWAVE RADIO SYSTEMS - GENERAL

The placing of cable plant is costly and is guided to a great extent by the configuration of the terrain over which it must pass. Furthermore, to provide the necessary bandwidth and compensate for the high degree of attenuation, vacuum tube amplifiers are required at relatively close intervals. In the L1 coaxial carrier system repeaters are spaced at approximately eight mile intervals, while in the wider band L3 system the spacing is at approximately four mile intervals. Aside from initial cost, this presents a major maintenance problem.

By the use of microwave radio transmission, employing highly directive antennas, it is possible to obtain line of sight transmission paths with repeaters spaced at an average distance of 30 miles. In some special cases distances as great as 55 miles have been covered. This is not as economically advantageous as it might at first glance appear, since the amplifiers for the coaxial system can be made up in small, pole mounted or manhole mounted cabinets, whereas a radio relay point involves a rather large and expensive building; antenna supporting structure; costly precision antennas; and the power supply and emergency power supply problems normally associated with isolated unattended station operation.

Other factors which might be compared, relate to the available number of channels per system. The normal coaxial cable system will provide eight wide band uni-directional channels, whereas the microwave systems currently used may provide as many as 24 channels of equivalent bandwidth. However, at the present time the maximum number of uni-directional broad-band channels applied to a microwave system is 12. This can perhaps be better appreciated by examining the frequency allocation which the F.C.C. has made for common carrier point-to-point service, as follows:

<u>Band (mc)</u>	<u>Available Bandwidth (mc)</u>	<u>Individual Channel Width (mc)</u>
3,700-4,200	500	20
5,925-6,425	500	20
10,700-11,700	1,000	20

The narrowest radio band of 500 megacycles appears voluminous at first glance when compared to the eight megacycle bandwidth of the present L3 coaxial system. However, the operating techniques used with our present coast-to-coast microwave system require an individual channel width of 20 megacycles. In order to provide a minimum of interference between channels, present operation uses a 20 megacycle separation or guard band between channels. As a result, a system such as the TD-2 provides a maximum of 12 wide band channels. By the use of a different type of antenna system and some equipment rearrangements, it will be possible to intersperse 12 additional channels between the presently assigned 20 megacycle channels with a minimum of interference.

CHAPTER 17 MICROWAVE RADIO SYSTEMS - GENERAL

Another factor often overlooked in the comparison of broadband channels, is that of transmission distortions. These, particularly with respect to phase, multiply rapidly as the number of amplifiers is increased.

It might also be well to point out that the efficiency of bandwidth utilization is not as great with microwave as with the carrier system. In the L3 carrier system frequency division multiplexing is used with single sideband transmission, permitting the application of 1,800 telephone channels to a single eight megacycle coaxial system. Due to factors which will not be discussed here, the microwave carriers are frequency modulated with the result that a 20 megacycle band is required to transmit the same 1,800 telephone channels.

In practice it has been found that a better grade of wide band facility can be provided as economically with microwave as that furnished with wire plant.

17.5 COMPARISONS BETWEEN WIRE AND RADIO TRANSMISSION CONCEPTS

General

The approach to radio transmission is somewhat different than the approach to wire line transmission and the terminology used may differ or have different interpretation. The following paragraphs will attempt to point out some of these differences:

Attenuation

In wire line circuits, we know that there is a definite loss of energy per unit length of facility for a specific frequency and a given type and condition of line. Wire line facilities are referred to as having a loss of so many db per mile, so that if the length of a circuit is known, the total attenuation can be obtained by multiplying the number of miles by the number of db loss per mile.

In radio transmission, the attenuation of signal between transmitter and receiver is not due to energy loss in the transmission medium, but is determined by the density of the radio field at the receiving antenna. Referring to our previous example, using the special flashlight bulb and the small piece of cardboard, it can be seen that as the cardboard is moved from the light source, it will intercept fewer of the light rays per unit of area. In the same way, the radio receiving antenna will intercept less of the transmitted energy as it is moved away from the transmitting antenna. This relationship is such that, for any given antenna arrays, doubling the distance between the antennas will introduce an additional six db loss. For example, if two antennas five miles apart are separated to a distance of ten miles, the overall path loss will be increased by six db. If they are

CHAPTER 17 MICROWAVE RADIO SYSTEMS - GENERAL

again separated to a distance of 20 miles, the overall path loss will be increased by an additional six db. This will continue as long as we can maintain a line of sight path.

Power Levels and Level Differences

Maximum levels, minimum levels and the level differences at a repeater are generally greater in radio than in wire plant. Probably the greatest level difference between the input and output of a repeater in wire plant can be found in the J carrier system under adverse conditions. In this system, a signal of one milliwatt, or 0 dbm, applied to the circuit terminal may leave a repeater at a level of +20 dbm and arrive at the next repeater input at a level of -60 dbm. Normal levels in a Type K carrier system may run in the order of -60 dbm at the input and +10 dbm at the output of a repeater. In voice frequency wire circuits, input levels are seldom lower than -10 to -15 dbm. These levels are normally dictated by crosstalk and noise considerations in the line facilities. In radio systems, on the other hand, a modest size transmitter may deliver 100 watts or +50 dbm to the transmitting antenna and a distant receiving antenna may deliver to its receiver a level of -100 dbm or a total loss between transmitter and receiver of 150 db. This is almost twice the repeater section loss of the J carrier system mentioned above. The greater loss in a radio section is compensated for by the use of higher transmitting levels and lower receiver input levels, since the same crosstalk considerations do not apply as they do in wire plant where high levels may induce crosstalk currents in adjacent conductors in the same line facility. A problem is introduced, however, at radio repeaters where input and output levels differ by such large amounts due to the likelihood of the transmitter output being fed back to the receiver input, in spite of highly directive antenna systems. This generally means that there must be a frequency shift in going through a radio repeater so that the transmitted and received signals will not be at the same frequency and result in a radio frequency singing path.

Interference Between Circuits

As we have mentioned, information may be transferred from one wire circuit to another wire circuit by induction. In a radio path, discrimination between two channels is primarily a function of the receiver's ability to reject unwanted signal frequencies, while efficiently passing signals of the desired frequency. Interference between two systems operating at the same frequency will be determined primarily by the distance between the systems and the directional characteristics of the antenna systems used. At the lower frequencies, interference may be introduced by unusual propagation conditions when the sky wave from a transmitter thousands of miles away may be bent or reflected in an unusual manner. In general, interference between radio circuits is avoided by the use of adequate frequency separation, of geographic separation as required and of modulation forms of a dissimilar nature.

CHAPTER 17 MICROWAVE RADIO SYSTEMS - GENERAL

Privacy

In a wire circuit, the energy is confined to the conductors and is generally shielded from radiating by lead sheath. As a result, eavesdropping on a wire circuit can only be accomplished at a terminal appearance, such as in a central office, at a switchboard or at a subscriber's termination. Since, as previously pointed out, the radio transmitter may produce radiation in all directions (except as confined by directional antenna systems) not all of the energy is collected by the receiving antenna and it is possible for unauthorized persons to copy the transmitted intelligence by means of suitable receiving equipment. The complexity of present microwave equipment and the relatively high directivity of the antenna systems does insure a relatively high degree of privacy at the present time. With increased development in the use of microwave equipments, additional steps may be required to insure an adequate degree of privacy. However, this does not appear to be an imminent consideration.

Level Variations

In wire circuits of appreciable length variations in received level of considerable magnitude may be expected on both a daily and a seasonal basis, e. g., temperature variations from day to night may introduce a total loss variation in the order of 50 db on a typical 1,000 mile H-44 voice frequency cable circuit. Similarly, a loss variation in the order of 1,000 db could occur in a Type K carrier system 4,000 miles in length. These variations must be compensated for at regular intervals along the circuit in order to provide a constant grade of overall transmission without allowing the input to any particular repeater reaching an excessively low value. Various types of automatic gain regulators are provided for wire circuits; however, their design and use is highly complex. Since the gain variation is not constant with frequency, it is necessary for the regulators to provide differing compensations in different portions of the frequency spectrum of the facility and to do this without the introduction of incidental distortions.

The level variation in a radio path is relatively small under normal conditions. At microwave frequencies the variation in received level seldom exceeds 20 to 30 db. Under fading conditions, however, wide variations of received signal may be expected for short periods. The level variations in a radio path are principally due to atmospheric conditions. Heavy rain may cause some loss but this is not a major factor at the frequencies currently being used. At 10,000 megacycles heavy rain causes less than 1 db per mile of attenuation and it is probably seldom that such rain would occur over an entire radio path at one time.

As previously mentioned radio waves transmitted through the earth's atmosphere may be refracted or bent in the same fashion as light waves are bent in passing from one transmission medium to another; such as from water to air or from glass to air. This type of phenomenon has probably been

CHAPTER 17 MICROWAVE RADIO SYSTEMS - GENERAL

observed by everyone. Under certain types of atmospheric disturbance the refractive index or bending ability of the atmosphere may change, sometimes at a periodic rate, resulting in sufficient bending to cause the transmitted radio waves to entirely miss the receiving antenna. This may result in very deep fades or complete loss of signal momentarily. During fading conditions the signal intensity at the receiver at any instant is closely related to frequency since the refraction of the radio wave is proportional to frequency. It is this phenomenon which makes it possible to maintain radio communication between two points during conditions of heavy fading by operating at a slightly different carrier frequency.

Output Power and Output Level

Operation of wire plant over the years has been conducted at very low energy levels. Power transmission is generally in terms of fractions of a milliwatt with intermediate amplification. As a result, it has become common practice to discuss wire transmission in terms of transmission levels as related to a reference level rather than in terms of actual watts power output of a particular component of the transmission system. By the use of power ratios related to a reference power of one milliwatt, in terms of the logarithmic unit of "db", it is possible to avoid the use of complicated numbers involving many zeros after the decimal point. In general, the problem is not to transmit large amounts of power as efficiently as possible but to transmit a small amount of power undiminished over long distances. The power output of the repeater or amplifier must be kept low enough so that crosstalk is not introduced into adjacent communication channels and the power handling capability of such an amplifier or repeater may be only great enough to produce this output level without distortion of the input signal.

In radio transmission the situation is somewhat different. It has been the practice to use large amounts of power at the transmitter in order to provide as much energy as possible at the most distant receiver. In the case of broadcast transmission it is not at all unusual to use transmitters which deliver as much as 50,000 watts to the antenna. As a result, it has become customary to rate radio transmitters in terms of power output rather than in terms of input or output levels. In the operation of microwave transmitters for Bell System services, the general procedure of the radio industry is not followed. Since the power outputs normally used are in the order of 0.3 to 1.0 watt, outputs are generally expressed in levels of db with respect to one milliwatt.

Antenna Gain

In wire-line transmission an impedance matching device is normally employed to transfer the energy between the wire-line facility and the amplifying or terminal equipment. In the same fashion an antenna is used to transfer energy between the radio equipment and the transmission medium of free space. In both instances there is a loss of power associated with

the transfer, the magnitude of which will vary with design. With this in mind it is, therefore, sometimes difficult to understand how an antenna can be considered to have gain.

A simple point source of radiation is called an isotropic antenna and is assumed to radiate energy equally in all directions into free space. Thus the field of free radiation is in the shape of a sphere and resembles the light radiation from the small flashlight bulb discussed earlier in this chapter. A single element antenna, one-half wave in length, is known as a dipole antenna. The radiation from this antenna has a form resembling a doughnut placed about the center of the antenna in a plane at right angles to the long dimension of the antenna.

In either case, signal for a receiver is obtained by placing a receiving antenna in the radiated field and so arranging and tuning it as to pick up maximum energy from the field. At any reasonable distance from the transmitting antenna the amount of energy or the area of the radiated field which the receiving antenna can intercept will be small when compared to the total radiation from the transmitting antenna.

Since the radio path loss is considered to be the ratio of the received energy to the transmitted energy, the radio path loss is accordingly large. It can immediately be seen that increasing the size of the receiving antenna will intercept more of the radiated field and, therefore, reduce the path loss. However, there are physical limitations to the size of a receiving antenna.

The increase in energy picked up by the enlarged antenna referred to the energy which would have been picked up by an isotropic antenna is called antenna gain. Since an isotropic antenna is a theoretical device gains are more often referred to the easily reproduced dipole.

As pointed out earlier, a reflector can be used to direct the radiation from the transmitting antenna toward the receiving antenna and thus increase the amount of energy intercepted by the receiving antenna and accordingly decrease the so-called path loss. This effectively produces an antenna gain.

Since the dipole antenna has some degree of directivity as evidenced by its doughnut shaped field, it produces an effective gain over an isotropic antenna. The actual gain of a dipole over an isotropic antenna is slightly over 2 db. It is therefore apparent that in discussing the gain of any antenna array it is first necessary to ascertain the base of reference since an antenna with a gain of 16 referred to a dipole will have a gain of 18 db when referred to an isotropic antenna.

CHAPTER 17 MICROWAVE RADIO SYSTEMS - GENERAL

It is not at all impractical to construct both transmitting and receiving antennas which in the 4,000 to 6,000 megacycle range will have effective gains of over 40 db.

17.6 RADIO TERMINOLOGY

The following terms are commonly used in discussions of radio transmission but have no counterpart in wire plant.

Radio Wave

A radio wave represents electrical energy that has escaped into free space. A radio wave travels with the velocity of light and consists of magnetic and electric fields at right angles to each other and also at right angles to the direction of travel. The intensity of the electric and magnetic fields of the wave are such that one-half of the electrical energy contained in the wave is in the form of electrostatic energy while the remaining half is in the form of magnetic energy.

Field Strength

The strength of a radio wave is expressed in terms of the voltage stress produced in space by the electric field of the wave, and is usually expressed in either millivolts or microvolts stress per meter. The stress expressed in this way has exactly the same voltage that the magnetic flux of the wave induces in a conductor one meter long when the wave sweeps across this conductor with the velocity of light.

Wave Front

The plane parallel to the mutually perpendicular lines of electrostatic and magnetic flux of the wave is termed the wave front. The wave travels in a direction at right angles to the wave front with the direction of travel depending upon the relative direction of the lines of electromagnetic and electrostatic flux. If the direction of either magnetic or electrostatic flux is reversed, the direction of travel is likewise reversed but reversing both sets of flux has no effect.

Polarization

The direction of the electrostatic lines of flux is termed the direction of polarization of the wave. Thus when the electrostatic lines are vertical the wave is said to be vertically polarized.

Troposphere

The Troposphere is the portion of the earth's atmosphere, some ten miles thick, immediately adjacent to the earth's surface. A small discontinuity in the refractive index of the troposphere, such as can exist at the boundaries of air masses having different moisture content, is capable of producing small reflections of radio waves of very high frequency. Such tropospheric reflections are of practical importance at frequencies above 30 megacycles.

CHAPTER 17 MICROWAVE RADIO SYSTEMS - GENERAL

Ionosphere

The outer portion of the earth's atmosphere is known as the ionosphere and consists of free electrons, positive ions, and negative ions in a rarified gas. The ionization of the outer atmosphere results from ultra-violet light and a form of ionizing radiation originating with the sun. The effect that the ionosphere has on radio waves is a result of the free electrons and is determined by the distribution of electron density in the upper atmosphere. The electron density at distances of 60 or more miles from the earth is sufficient to influence radio waves causing reflection and bending. The maximum electron density (and the exact way in which the density varies with height) depends upon the time of day and the season, and also varies from year to year.

The electron density of the ionosphere varies in strata or layers which are alphabetically designated. The most important of these are the E layer, the F1 layer and the F2 layer. The E layer has a virtual height of around 60 to 70 miles while the F2 layer has a virtual height which varies from 150 to 250 miles. At night the E and F1 layers may tend to fade out while the F2 layer descends. This accounts for the variation in reception between night and day of radio frequencies which are reflected by the F2 layer.

Sky Waves

The term "sky wave" refers to energy that is propagated in the space above the earth under conditions such as to be affected by the ionosphere. The sky wave accounts for long distance communication of all types except at the very lowest of radio frequencies. The variation in the height of the ionosphere and the resultant variation of the point at which the reflected sky wave arrives accounts for the variation in signal intensity between day and night, winter and summer, etc. in long distance signals.

Ground Wave

When the transmitting and receiving antennas are at the surface of the earth and are vertically polarized a ground wave exists that is supported at its lower edge by the presence of the earth's surface. It is this ground wave (sometimes called surface wave) that accounts for the propagation of broadcast signals in the daytime.

Space Wave

When the antennas are elevated then, in addition to the ground wave that depends upon the presence of the earth's surface for its existence, energy also propagates in the space above the earth in a manner that does not depend upon the earth's surface. This space wave can be considered as consisting of a ray traveling directly from transmitting to receiving antenna plus a ground reflected ray. The space wave represents the principal means by which energy reaches a receiving antenna at frequencies above 30 megacycles.

CHAPTER 17 MICROWAVE RADIO SYSTEMS - GENERAL

Reliability

The reliability of a circuit is generally taken as the percentage of a 24-hour period during which it furnishes dependable transmission. When studies of radio path reliability are made the only lost time considered is that due to the radio path itself and does not include time lost due to equipment defects, etc.

17.7 MODULATION

In amplitude modulation a carrier frequency is varied in amplitude in accordance with the amplitude of the intelligence signal to be transmitted. The rate of amplitude change is the same as the rate of signal amplitude change. An AM carrier is said to be 100% modulated when the peak amplitude of the modulated current wave is twice that of the amplitude of the unmodulated current wave.

In frequency modulation the frequency of the carrier wave is varied an amount proportional to the amplitude of the intelligence signal to be transmitted. The rate of frequency variation of the carrier is the same as the rate of amplitude variation of the modulating signal. A frequency modulated carrier is said to be 100% modulated when the peak frequency change is equal to the rated peak change for the transmitter in question. The change in frequency from the normal carrier frequency in an FM carrier is referred to as the deviation.

Another term which is used to describe the characteristics of an FM transmitter is the deviation ratio. This is the ratio of the maximum transmitter frequency deviation to the maximum modulating frequency.

A term which is useful in discussing the sideband content of an FM signal is the modulation index. This is the ratio of the deviation to the modulating frequency.

Frequency Modulation (FM)

Figure 17-2 illustrates frequency modulation of a carrier wave.

The following three statements should be studied carefully as specifications of FM:

- a. The amplitude of the carrier remains constant as the carrier frequency is varied by modulation.
- b. Deviation (i. e., frequency swing) is proportional to the amplitude of the modulation.
- c. The rate of frequency change is proportional to frequency of the modulated signal.

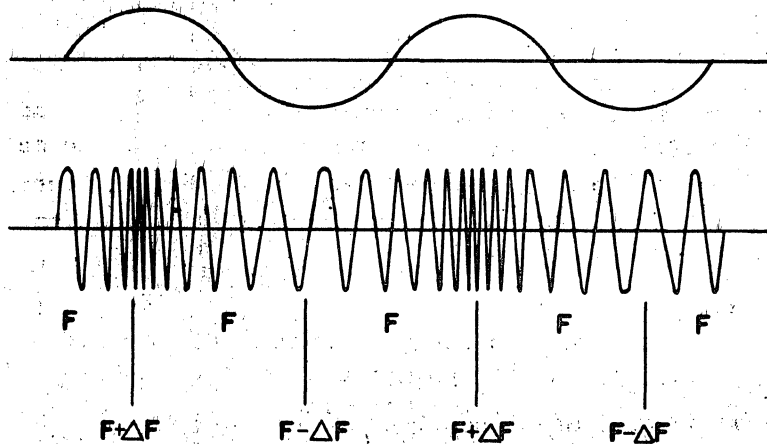

Fig. 17-2 - Frequency Modulation of Carrier Wave

Very closely associated with Frequency Modulation is Phase Modulation (P. M.). The following three statements should be studied as specifications of PM:

- a. The amplitude of the carrier remains constant as the carrier frequency is varied by modulation.
- b. Phase swing is proportional to the amplitude of the modulation.
- c. Deviation (frequency swing) is proportional to frequency of the modulation.

Comparison of FM and PM

It is apparent that it is impossible to vary either frequency or phase independently. Indeed, frequency is defined as the time rate of change of phase. Figure 17-3 shows a comparison of FM and PM. In each case the modulating signal (deliberately chosen not to be a sine wave) is identical. In case of FM, the carrier frequency is seen to vary in proportion to the signal, but in the case of PM the phase varies in proportion to the signal. In both cases, the second curve (carrier frequency) is seen to be a plot of the slope of the third curve (carrier phase).

FM Modulation Methods

Various schemes may be used to produce frequency modulation. A simple (but inefficient) method is to use a condenser microphone in an oscillator tuning circuit. In this case, sound waves will vary the capacity of the microphone and the oscillator frequency will vary in direct relation to the amplitude of the sound waves.

Another, and better method for frequency modulation utilizes a reactance tube. By means of a suitable circuit, a tube may be caused to act like a reactance (coil or condenser) and its reactance may be varied in accordance with a signal applied to its grid. If such a reactance tube be

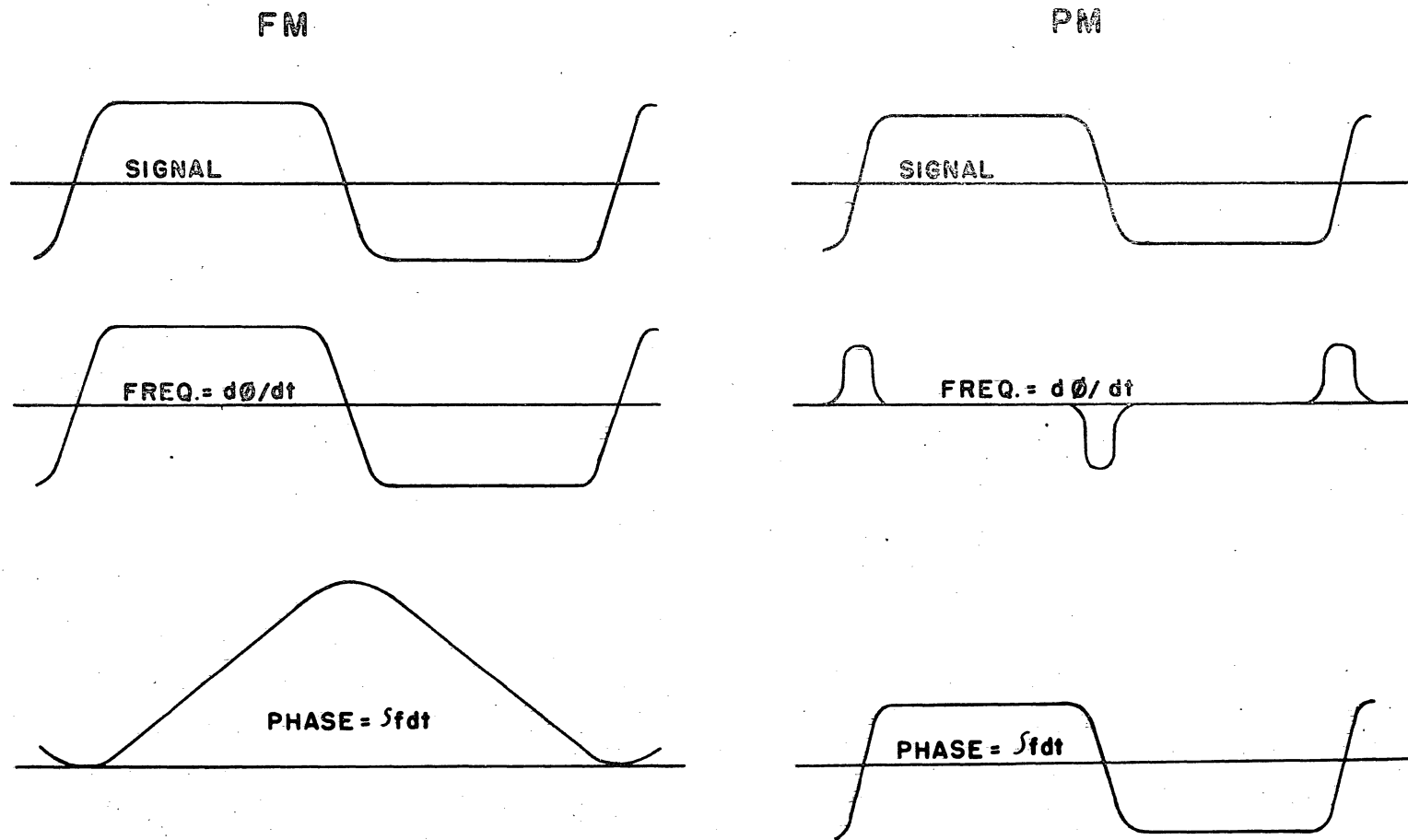

17.21

Fig. 17-3 - Comparison of FM and PM

CHAPTER 17 MICROWAVE RADIO SYSTEMS - GENERAL

connected in parallel with the tank circuit of an oscillator, the frequency of the oscillator will vary in direct relation to the amplitude variations of the signal applied to the reactance tube.

Still another method, the phase-shift method, is to use a phase splitter to feed the carrier with equal magnitude but with a 90-degree phase difference to the control grids of two paralleled amplifiers. The modulating signal is then fed to another grid of the tubes in push-pull. In the paralleled plate outputs of the two tubes the resultant voltage then varies in phase in accordance with the modulating voltage. (This is PM, but may be converted to FM by pre-distorting the modulating signal).

FM Detection

Figure 17-4 shows a block diagram of a typical FM receiver.

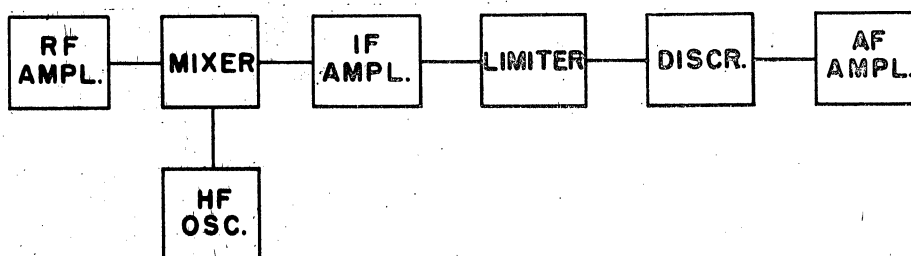

Fig. 17-4 - Typical FM Receiver

In such a receiver the modulated carrier is first amplified, then beat down by combination with an oscillator frequency in a mixer stage which has its plate tuned to the difference of the carrier frequency and the oscillator frequency. The intermediate frequency which results is then amplified and fed to a limiter. The limiter, which is a grid-leak biased amplifier with low plate and screen voltage, limits negative peaks by cutoff and limits positive peaks by grid action (not by plate saturation). The output of the limiter is constant-amplitude FM which is fed to a discriminator. The discriminator (FM detector) has zero output, both ac and dc, if the carrier is unmodulated and is exactly on the receiver frequency. If the carrier is modulated, the discriminator has an ac output equivalent to the modulating signal.

17.8 RADIO SYSTEMS

Types of Radio Systems

The essential elements of any radio system are (1) a transmitter for modulating a high-frequency carrier wave with the signal, (2) a transmitting antenna that will radiate a maximum amount of the energy of the modulated carrier wave, (3) a receiving antenna that will intercept a maximum amount

CHAPTER 17 MICROWAVE RADIO SYSTEMS - GENERAL

of the radiated energy after its transmission through space, and (4) a receiver to select the carrier wave and detect or separate the signal from the carrier. Although the basic principles are the same in all cases, there are many different designs of radio systems. These differences depend upon the types of signal to be transmitted, the distances involved, and various other factors, including particularly the part of the frequency spectrum in which transmission is to be effected.

Figure 17-5 is a chart of the radio spectrum indicating at the left the commonly accepted classification of radio frequency ranges; and showing at the right the more important frequency ranges of special interest in

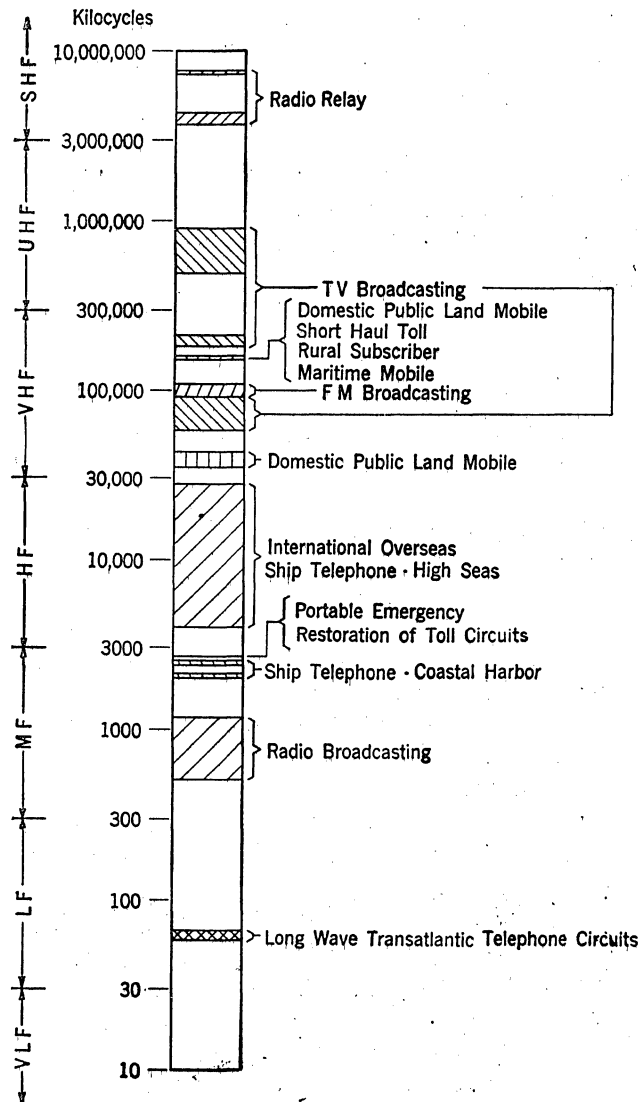

Fig. 17-5 - Radio Frequency Spectrum

CHAPTER 17 MICROWAVE RADIO SYSTEMS - GENERAL

current telephone practice. It will be noted that telephone practice makes use of some part of nearly all of the major frequency ranges. It must accordingly employ a corresponding variety of types of radio facility. It is not practicable or desirable to attempt to describe all of these in this book, and what follows will therefore be limited to a brief general discussion of principles applicable to all radio systems, with a few examples of specific facilities.

Radio Transmitters

The principal components of a typical amplitude-modulated radio transmitter, such as might be used in radio broadcasting or for relatively low-powered point-to-point transmission, are indicated in the block diagram of Figure 17-6. Here the amplified input signal plate-modulates the carrier in the output circuit of a Class C power amplifier which represents the final stage in a chain of amplifiers that increases the power of the carrier to an appropriate value for application to the antenna.

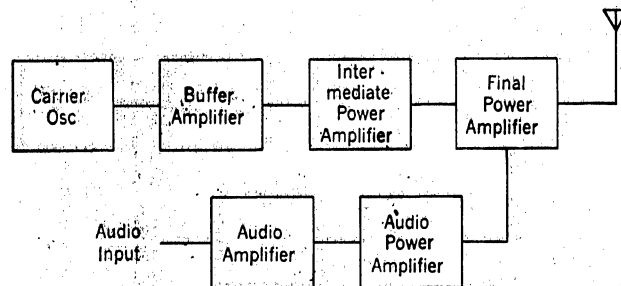

Fig. 17-6 - AM Radio Transmitter - High-Level Modulation

For very long distance point-to-point radio telephone circuits, such as those used in transoceanic service, transmitter design is naturally somewhat more elaborate.

As was pointed out earlier, there are a number of different types of circuits in use for frequency modulating a radio carrier wave. Figure 17-7 indicates in block schematic the arrangement of an FM transmitter in which modulation is effected by means of a reactance tube circuit. Because FM radio (voice) transmission is generally in the very high-frequency range, it is necessary to use frequency multiplying circuits to bring the basic frequency generated by the master oscillator up to the desired value. The oscillator usually operates in the neighborhood of 5 mc, and its output frequency must be multiplied by factors in the order of 10 to 20 to reach the frequencies prescribed for FM transmission. Two or three frequency-multiplication stages are usually employed for this purpose.

CHAPTER 17 MICROWAVE RADIO SYSTEMS - GENERAL

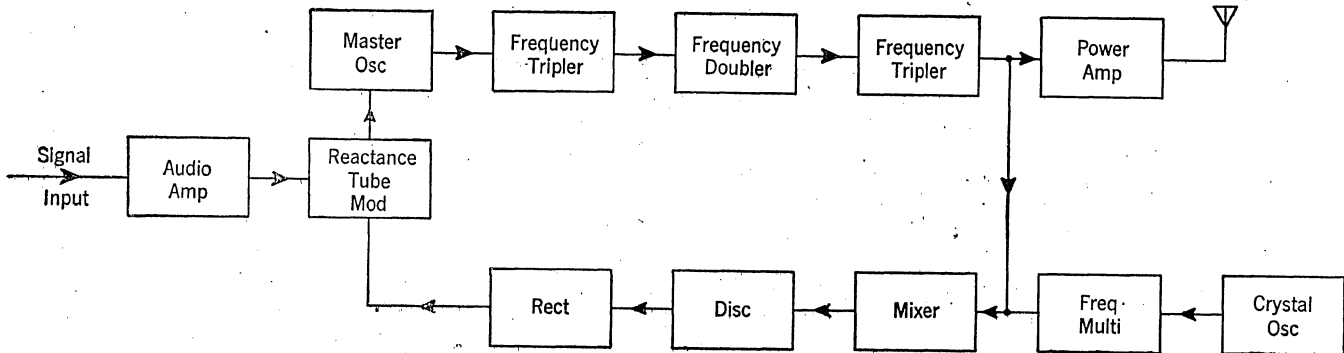

Fig. 17-7 - FM Transmitter Using Reactance Tube

In order to maintain the carrier frequency at a fixed value, the reactance tube type of transmitter requires the use of an automatic frequency control arrangement as shown in the lower part of Figure 17-7. This includes a crystal-controlled oscillator of highly stable frequency. A portion of the modulated carrier is picked off and compared in a mixer (modulator) circuit with the output of the crystal oscillator. The difference between the two frequencies, if any, is fed to a discriminator, the output of which, after rectification, is applied to the grid of the reactance tube. The polarity of this rectified output will be such as to hold the mean frequency of the master oscillator effectively constant under the control of the crystal oscillator.

Radio Receivers

The radio signals that are picked up by the antenna of a radio receiver are usually very weak so that the receiver circuit must ordinarily include one or more amplifiers.

The vast majority of modern receivers are of the "superheterodyne" type illustrated in block schematic in Figure 17-8. Here, before detection, the r-f signal is converted by a modulation process to a fixed intermediate frequency value in which most of the required amplification takes place. The incoming signal is selected by a variable tuned circuit, which in some cases may include one amplification stage. A local oscillator, which supplies the mixer or demodulator (also sometimes called a converter or first detector), is tuned simultaneously with the signal selecting tuner so that the frequency of the mixer output, which is the difference between the frequencies of the oscillator and the incoming carrier, is always the same. The intermediate frequency amplifier circuits, accordingly, require no adjustment and may employ coupled circuits double-tuned to a single constant frequency. Radio broadcast receivers are usually designed for an intermediate frequency value of about 450 kc. Figure 17-8 indicates a local oscillator separate from the mixer circuit, but in most

broadcast receivers a single multi-grid tube known as a "pentagrid converter" performs both the oscillator and mixer functions.

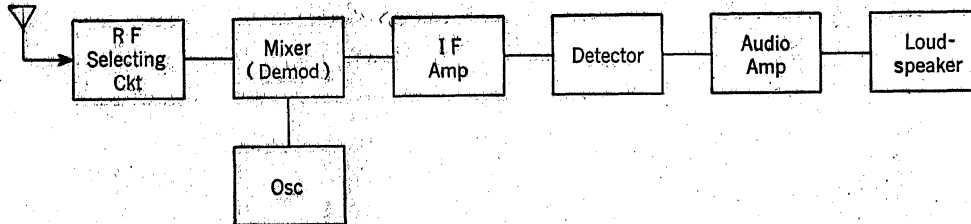

Fig. 17-8 - Superheterodyne Radio Receiver

The superheterodyne receiver, although its advantages are sufficient to warrant its general use, has some inherent capacity to produce spurious responses under certain conditions. One of the major sources of such undesired responses is the possible presence at the antenna of a signal whose value is the "image frequency" of the tuned-in signal. The frequency of the image signal is greater than the frequency to which the receiver is tuned by twice the value of the intermediate frequency if, as is normally the case, the local oscillator is operating at a higher frequency than that of the desired signal. Such an image signal will mix the oscillator frequency to produce a difference frequency that is exactly equal to the intermediate frequency. Thus, both signals would be amplified in the IF section and appear simultaneously in the receiver output.

Receiver response to image signals can only be avoided by blocking the image in the selecting circuits that precede the mixer. This is facilitated by the use of an intermediate frequency which will cause the image of the desired signal frequency to lie at a considerable distance in the frequency band from the desired frequency. For example, if the intermediate frequency is 450 kc, and the receiver is tuned to a signal carrier at 800 kc, the oscillator frequency must be 1,250 kc. With this oscillator frequency, the image signal that would produce a 450 kc intermediate frequency would be 1,250 kc plus 450 kc or 1,700 kc. This is sufficiently removed from the 800 kc signal so that little, if any, is likely to pass through the tuned selecting circuit to reach the mixer.

For reception of long distance point-to-point signals, as in transoceanic service, a more elaborate receiver employing two intermediate frequencies is often used. This arrangement is sometimes known as a triple-detection receiver. The first intermediate frequency has a relatively high value to permit maximum image suppression, and the second intermediate frequency is comparatively low to provide high adjacent channel selectivity.

CHAPTER 17 MICROWAVE RADIO SYSTEMS - GENERAL

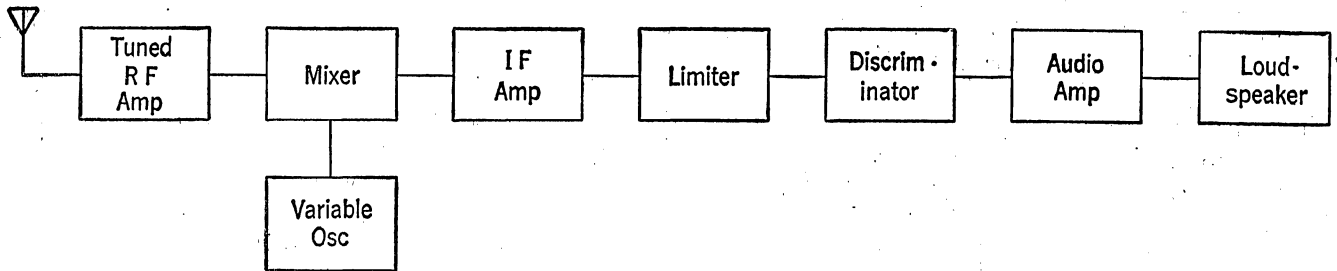

Fig. 17-9 - Frequency-Modulation Receiver

The pre-detection stages of receivers for FM signals are generally the same as those of AM receivers. As shown in Figure 17-9, however, detection in this case is effected by means of limiting and discriminating circuits. For best results, IF amplification should be great enough to raise all peaks of the signal above the cut-off point of the limiter. This will automatically eliminate any amplitude variations that may be present so that the signal at the output of the limiter will have a uniform fixed amplitude and will vary only in frequency. By eliminating amplitude variations, noise and unwanted energy which are the chief causes of such variations are minimized. The discriminator converts the constant amplitude frequency-variations into an audio-frequency signal, which is then amplified in the usual manner.

Radio Transmission

In analyzing the total energy losses that may occur in the transmission of electric power from one point to another, it is necessary now to consider another phenomenon which has, up to this point, been ignored. This is the loss due to radiation.

In 1864, James Clark Maxwell undertook to set up a series of mathematical equations that would provide a general statement of the relationships between electric and magnetic fields under any and all conditions. In rounding out this series of equations to achieve mathematical symmetry, he was led to some very interesting conclusions. The equations seemed to indicate that the hitherto existing assumption that all of the energy contained in the electric and magnetic fields accompanying the flow of current in a conductor returned into the conductor when the source of emf was cut off was not wholly true. Some part of the field, it appeared, would detach itself entirely and escape into space in the form of electromagnetic radiation, carrying with it a comparable part of the total energy.

This led to the further conclusion that a moving electric field can exist in the absence of any electric charges, despite the fact that an electric field is usually thought of as being made up of lines of electric force always

CHAPTER 17 MICROWAVE RADIO SYSTEMS - GENERAL

terminating on electric charges. Furthermore, if a moving electric field can exist independently in space, it must be thought of as being equivalent in certain ways to a flow of electric current. In other words, the moving electric field in free space must set up, or be accompanied by, a moving magnetic field just as it would be in the case of current flow along conductors.

The Maxwell equations cannot be written in any form that does not involve branches of mathematics which are beyond the scope of this book. With respect to radiated energy, however, the equations indicate, and experience confirms, that for a given current the amount of energy radiated depends upon the square of the frequency. Naturally the amount of radiation also depends upon the intensity of the current. What is of major significance from a practical viewpoint is the fact that the amount of radiation goes up very rapidly as the frequency increases. There is always radiation whenever there are changing current values but at voice frequencies, and at frequencies well up into the ordinary telephone "carrier range," the amount of radiation is negligible for most practical purposes. At frequencies that are measured in megacycles, on the other hand, radiation may cause losses that are much greater than any R losses in the conductor.

It was not until some twenty years after Maxwell developed his famous equations that Heinrich Hertz demonstrated experimentally the truth of the electromagnetic radiation hypothesis; and it was some years later before experimenters began to develop methods for taking advantage of this radiation phenomenon to transmit electric energy through space for useful purposes. In this case the objective was not to avoid energy losses by radiation but to do everything possible to facilitate maximum radiation. Since, as we have seen, the amount of radiation increases with frequency at a geometric rate, purposeful radio transmission naturally involves the use of high frequencies and transmission lines or antennas designed to radiate maximum energy.

If the transmission of the radiated energy were through unobstructed space in the form of electromagnetic waves like light waves, there would be no loss of energy "along the line" because there would be nothing to absorb the energy. If energy could be radiated from a given point and confined in a narrow beam extending directly to the receiving point, this means of transmission could be far superior to any wire transmission because of this lossless quality. However, the natural tendency of any radiator, isolated in space, is to send out energy in practically all directions although only such energy as actually reaches any receiving point is useful.

CHAPTER 17 MICROWAVE RADIO SYSTEMS - GENERAL

"Line losses" in radio transmission should largely be thought of not as energy losses in the transmission path itself, such as occur in wire lines, but as energy escaping entirely from the effective transmission path. The basic transmission problem, accordingly, is to devise methods that will direct the path of the radiated energy. Such methods are concerned primarily with the radiating antennas and it is customary in radio work to measure the effectiveness of antennas in controlling the directivity of radio propagation in terms of antenna gain. This is merely a measure in decibels, or other appropriate units, of the amount of energy received at a given point from a given transmitting antenna compared with what would have been received if the transmitting antenna radiated with uniform strength in all directions. Thus, high antenna gain in radio transmission corresponds to low line loss in wire transmission.

As is discussed briefly later in this Chapter, it is possible to design antennas with quite high gains -- particularly in the superhigh-frequency range (thousands of megacycles). There is no practical possibility, however, of designing antennas with such directivity that all, or even a major part, of the transmitted energy will reach a receiver located at any great distance from the transmitter. In other words, there must always be a very substantial effective loss of energy. What is perhaps worse, this lost energy may be absorbed elsewhere where it may interfere with other communication circuits, or be received at unauthorized points in such a way as to militate against the privacy of the transmission. There remain, therefore, obvious advantages in the employment of physical facilities that guide the energy directly to the desired receiving point. An ordinary wire line is one type of such a guide but is satisfactory at only relatively low frequencies because its radiation and other losses become too great at high frequencies. A coaxial is a better guide because the outer tube acts as a shield to prevent any of the electromagnetic energy transmitted within the tube from radiating into space. At frequencies in the thousands of megacycles, however, the losses of any practical design of coaxial also become very high. The usefulness of radio transmission in practice is found in two principal situations. The first is where it is impossible or economically impractical to construct physical facilities that will guide the energy. Here the application is in transmission over large bodies of water or to moving points such as ships at sea, motor vehicles, trains, and aircraft. The second situation is point-to-point service over land where radio transmission is considered more economical on an overall basis than other methods. A major application here is to microwave radio relay systems. But even in this case, it is necessary to use some form of physical transmission medium to guide the energy through the relatively short distances from the transmitter itself to the transmitting antenna, and from the receiving antenna to the receiver. Within limits, shielded wire lines or coaxials can be used for this purpose. More effective, however, are the simple hollow metal tubes commonly known as waveguides.

17.9 WAVEGUIDES

It is probably easiest to think of a waveguide as a device which merely isolates a particular path in space. Propagation of energy through the guide is then essentially no different from ordinary radio propagation, except that it is confined to this particular isolated path. However, the transmitting path, i. e., the space of the interior of the guide, must be large enough to permit the traveling electric and magnetic fields to assume configurations comparable to those that they would naturally assume when traveling in free space. It can be shown that for effective propagation a waveguide must have a maximum cross-sectional dimension at least equal to one-half the wavelength. This automatically limits the practical use of waveguides to the transmission of very high frequencies, where wavelengths are of the order of a few inches.

Waveguides commonly used in telephone practice are rectangular in shape as illustrated in Figure 17-10, with the dimension b greater than one-half wavelength but not greater than one wavelength. The dimension a is not critical but is usually about half as large as b . In such a guide the electric field tends to arrange itself as shown in Figure 17-11(A) with the lines of electric force extending vertically between the top and bottom guide walls

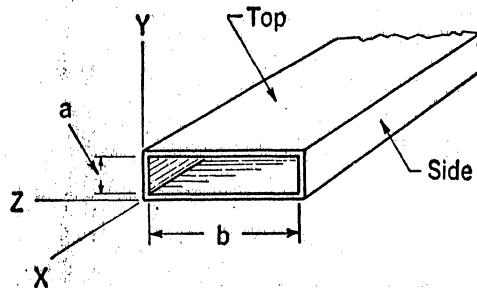
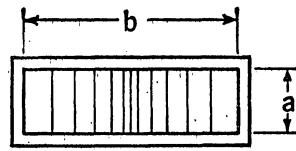

Fig. 17-10 - Rectangular Waveguide

and having maximum intensity at the center, and tapering off to zero at the sides of the guide. The magnetic field is at right angles to the electric field as shown in Figure 17-11(B). The lines of magnetic force, as indicated, are closed loops and the magnetic field has its greatest intensity along the sides of the guide with minimum intensity in the center where the electric field is the greatest.

If the interior walls of the guide are perfectly conducting, the lines of force of the electric field must always be perpendicular to the top and bottom walls; and the field at the side walls must be zero because the field there would be short-circuited. Similarly, the magnetic field must always be parallel to the side walls of the guide and can have no perpendicular

CHAPTER 17 MICROWAVE RADIO SYSTEMS - GENERAL



(A) Front View

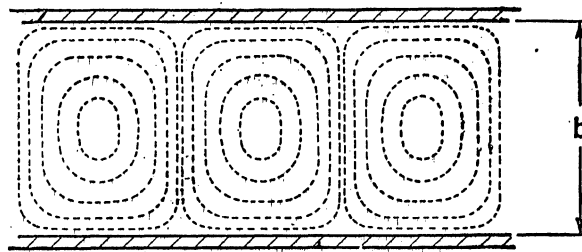

(B) Top View
Fig. 17-11

component which will cut through the conducting surfaces because any such component would set up a current that would in turn set up a magnetic field exactly opposite to the exciting field. All this is to say that if the inner surface of the guide is a perfect conductor, the traveling wave in the guide would at all times be a plane wave without any curvature whatever. Under these conditions energy would travel in the guide with practically no loss since no appreciable energy can be absorbed by the air dielectric. Actually, the inner surfaces of the guide are not perfect conductors, although copper and sometimes silver-plating is used in their construction. As a result, the actual configuration of the fields in the guide tend to deviate slightly from the ideal plane form. This results in some movement of the electrons in the surfaces of the guide and some consequent I^2R energy losses. At 4,000 megacycles the loss in a 1-1/4 X 2-1/2 inch bronze guide is about 1.5 db per 100 feet. In terms of the losses that we encounter at low frequencies in ordinary wire transmission lines, this is extremely high. It is nevertheless substantially lower in the microwave region than would be caused by the usual types of wire line or coaxial cable. The velocity of propagation of energy in a waveguide approaches but is always somewhat less than the speed of light.

Like any other transmission line, the waveguide should be uniform in structure along its total length. Any discontinuity such as changes in its size or shape, holes in the guide walls, or foreign conducting materials in its interior, will cause reflections and consequent energy losses. For the same reason care has to be used in designing bends or twists in the guides. In connecting different types of guides together, or in connecting them to antennas or energy sources, methods of impedance matching

CHAPTER 17 MICROWAVE RADIO SYSTEMS - GENERAL

similar in general principle to those applying in wire or coaxial lines must be employed to avoid reflection losses.

If a waveguide is "shorted" (i. e., closed by a conducting end plate) at its far end, total reflection will occur just as when a wire transmission line is shorted. If the waveguide is shorted at a point which is an odd multiple of a quarter wavelength distant from the energy source, the reflected wave will add in phase to the incident wave to set up a standing wave in the guide. In other words, the guide is now a resonant line and relatively large amounts of energy will surge back and forth between its contained electric and magnetic fields when energized or excited by the appropriate resonant frequency. This is the phenomenon that is taken advantage of to produce the cavity resonators that we shall encounter later.

Thus if a section of waveguide one half wavelength long is closed at both ends to form a small box and energized at the center point, it may be considered as two quarter wave lines, each of which is resonant. The cavity then acts in the same manner as an ordinary parallel resonant circuit made up of an inductor and a capacitor where likewise at the resonant frequency relatively large amounts of energy may surge back and forth between the magnetic field of the inductor and the electric field of the capacitor.

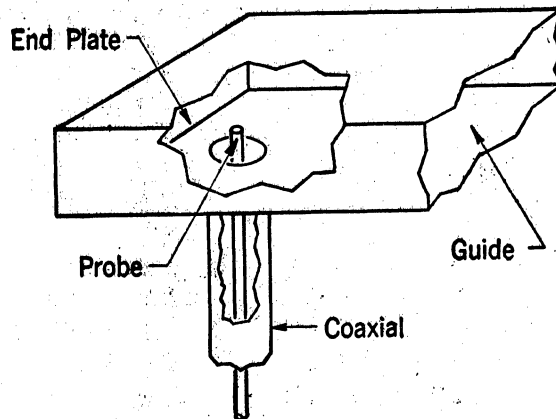

Fig. 17-12 - Probe Type Coaxial To Waveguide Transducer

The most common method for energizing or exciting a waveguide is indicated in Figure 17-12. Here the central conductor of a coaxial is inserted vertically into the center of the guide, where the electric field has its maximum value. This probe acts like an antenna in delivering energy to the guide, or in removing energy from it. The outer tube of the coaxial is connected electrically and mechanically to the wall of the guide and the impedances are matched by locating the probe at a point slightly less than

CHAPTER 17 MICROWAVE RADIO SYSTEMS - GENERAL

one-quarter wavelength from the closed end of the guide so that reflections from the end plate will be in phase with, and add to, the traveling wave in the tube. Guides can also be energized by inserting a loop as shown in Figure 17-13 at a point in the wall of the guide where the magnetic field is most intense.

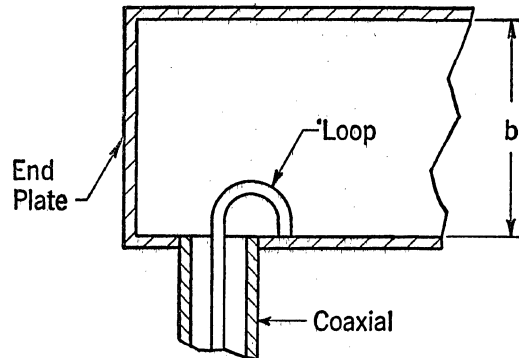

Fig. 17-13 - Loop Type Coaxial To Waveguide Transducer

In the above discussion we have deliberately confined our attention to a single configuration of the electric and magnetic fields in the waveguide. The configuration discussed is designated technically as the TE_{10} "mode." This mode will permit the transmission of the lowest frequency for a given size guide. If a guide is made larger so that its maximum dimension is greater than one wavelength, other configurations or modes of the fields become possible. The dominant mode discussed, however, is the one of major applicability in telephone practice.

17.10 MICROWAVE COMPONENTS

General

It is quite general practice to think of the resonant or tuned circuits in radio systems as consisting of a coil or inductor and a capacitor connected either in parallel or in series. Both the parallel connected and the series connected circuits may be used as the input or output load circuits for vacuum tubes. As a result, part of the capacity which determines the condition of resonance is contributed by the vacuum tube (and the associated wiring) or other components which may have distributed capacitance to the chassis or to other components in the circuit.

Since the resonant frequency is inversely proportional to the product of the inductance and capacitance, either or both of these elements must be reduced in magnitude to secure an increase in resonant frequency. In the 150-200 megacycle frequency range, it is not uncommon to have a tuned circuit consisting of a single turn of wire to furnish the inductance,

CHAPTER 17 MICROWAVE RADIO SYSTEMS - GENERAL

with no external capacitance, depending entirely upon the capacitance between opposite sides of the turn of wire and the distributed circuit capacitances.

It is therefore apparent that, as we approach the frequency range normally considered as microwave, tuned circuits would become microscopic in size if the conventional coil and capacitor arrangement were retained. In addition to being physically impracticable, the power handling capability of such circuits would be so small as to render them useless.

It will be remembered from previous chapters that quarter wave sections of transmission line appear as resonant circuits and that as the length is varied, these sections of line appear as reactances having predominantly inductive or capacitive component depending upon the length. As the operating frequency is raised, therefore, it has become common practice to substitute sections of transmission line which may be either terminated in a short or open depending upon the operating conditions, instead of the usual coil and capacitor resonant circuit.

It will also be remembered that a waveguide has many of the characteristics and is assumed to be composed of quarter wave sections of transmission line. This being the case, it is only natural that we should resort to waveguides and sections of waveguide with various configurations to form the resonant or tuned circuits that are necessary for the generation and amplification of energy at microwave frequencies.

This chapter will be devoted to a discussion of some of the more common microwave components that are related to waveguide construction. Not all of the possible combinations are considered in this chapter since many of these have no present Bell System application. The descriptions, therefore, are confined to those elements or components which are currently used in the microwave equipments employed for Bell System service.

It might be of interest to point out that many of these waveguide components, for example - directional couplers; transducers; terminations; etc., have become so standardized in the industry that they are furnished by microwave component suppliers in the same fashion that vacuum tubes are furnished for the low frequency radio equipments and a manufacturer of microwave systems will design his equipment around these standard components. As an illustration, a Philco microwave system would have an electrical design and physical arrangement which would be original with Philco, but could very readily use a directional coupler manufactured by Polytechnic Research and Development or an antenna horn and reflector manufactured by Work Shop Associates in the same fashion as the Wilcox Radio Company might build a VHF radio system and equip it with Eimac vacuum tubes.

CHAPTER 17 MICROWAVE RADIO SYSTEMS - GENERAL

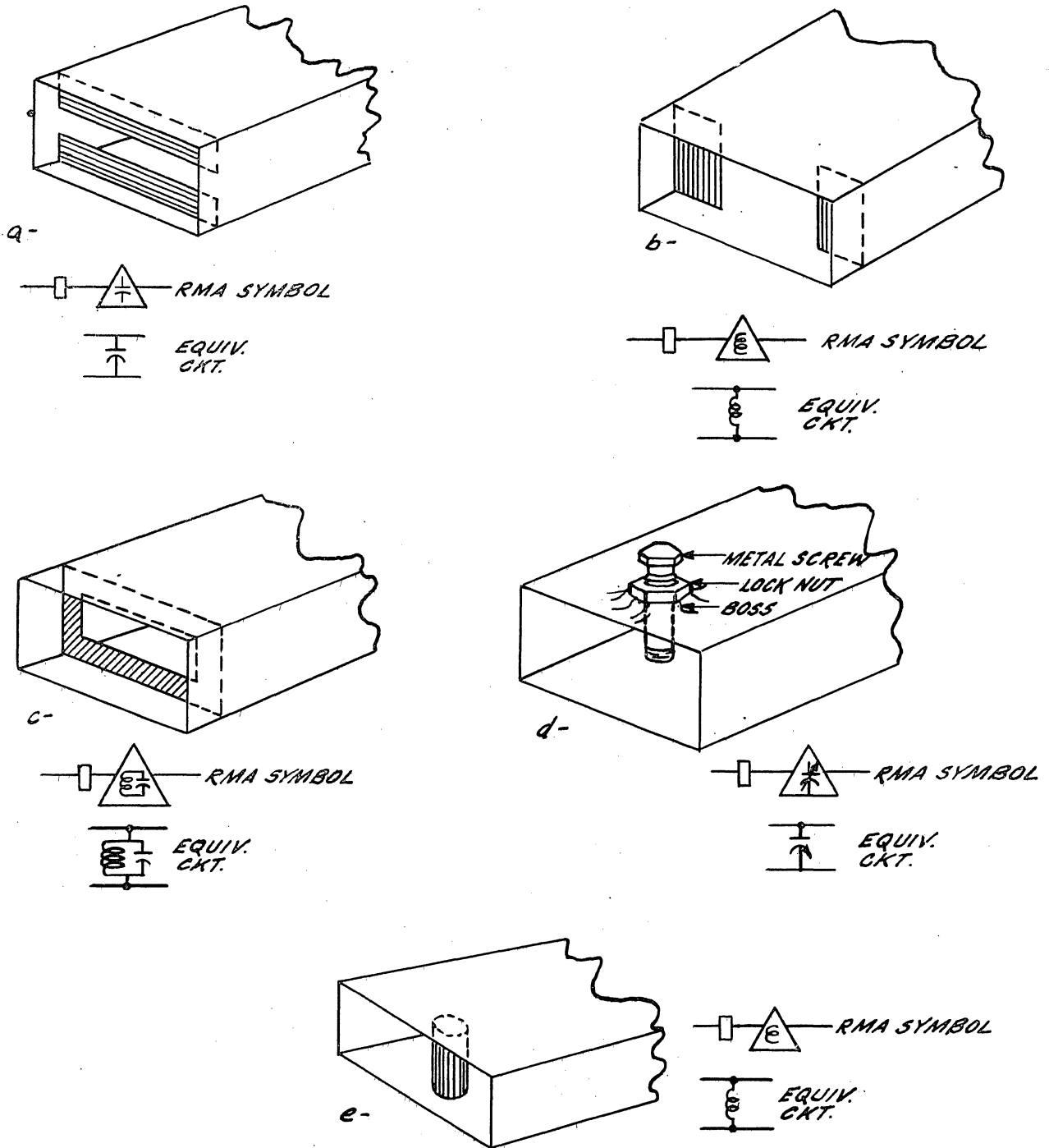

Fig. 17-14 Reactive Wave Guide Elements

CHAPTER 17 MICROWAVE RADIO SYSTEMS - GENERAL

Reactive Elements

If a partition is placed across a waveguide as shown in Figure 17-14A, it will distort the electrostatic field. Electrons will accumulate on the sides of the partition, first on one half and then the other and the resultant effect will be that of a shunt capacitor. This arrangement is called an iris or window.

In the same way a post may be extended from one side of the waveguide into the electric field, as shown in Figure 17-14D. This also will distort the electric field and will appear as a shunt capacitance. This type of post is called a capacitive stub and is usually threaded so that it may be screwed in or out of the waveguide and act as a variable capacitor.

If the partition is now placed vertically in the waveguide as shown in Figure 17-14B, it will distort the magnetic field due to currents flowing vertically in the partition and producing a resultant magnetic field. This type of iris or window thus acts as a shunt inductance.

In the same fashion, a post may be placed in the waveguide connecting the two parallel surfaces as shown in Figure 17-14E. This again will have current flowing through it and will distort the magnetic field and thus appear as a shunt inductance across the waveguide. If the post is made small in diameter, it will have relatively high inductance as well as considerable surface resistance due to the small surface area. If the post is made large in diameter, the inductance will be lower but the Q will be much higher due to the reduced surface resistance. A corresponding effect can be obtained with the window.

By combining the capacitive and inductive windows, a resonant slot or window is formed as shown in Figure 17-14 C. This will appear as a parallel resonant circuit having a frequency response proportional to its physical size.

Reactive elements of these types may be used as resonant circuits or for impedance matching in the same way that quarter wave stubs are used on transmission lines as discussed in previous chapters.

Waveguide Filters

At super-high frequencies it is impracticable to use tuned circuits, such as we have been discussing, employing coils and capacitors. Analogous principles apply, however, in the design of waveguide filters. Thus the resonant cavity, which we have already considered as being comparable in many respects to the parallel-resonant tank circuit, now becomes the basic element of the waveguide filter. Superficially, at least, if such a cavity is inserted in a waveguide it might be expected to pass a narrow band of frequencies centering about its resonant frequency, and to reject other frequencies.

CHAPTER 17 MICROWAVE RADIO SYSTEMS - GENERAL

Figure 17-15(A) is a sketch of such a resonant cavity designed for insertion in a waveguide having the same cross-sectional internal dimensions as the cavity. The screw shown centered in the top wall of the cavity is

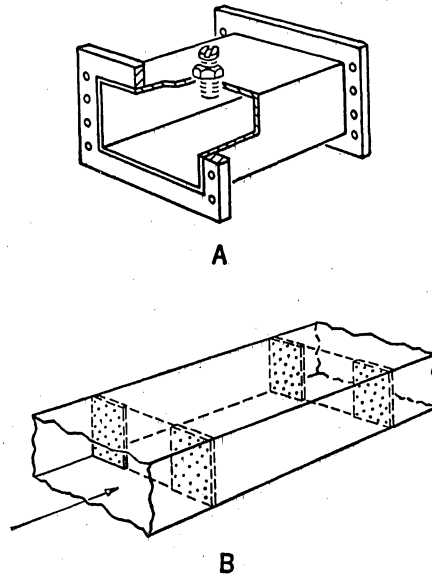

Fig. 17-15 - Waveguide Band-Pass Filter Section

located in the region of the strongest electric field. Its presence tends to shorten the electric lines of force and thus has an effect similar to increasing the capacitance in an ordinary tank circuit. In other words, inserting the screw farther into the cavity lowers the frequency of resonance of the cavity. This result is effectively the same as if the length of the resonant chamber were increased. When the cavity is inserted in the guide its ends are enclosed by thin plates which, however, must contain openings to permit the wave of energy to pass through. The openings in the end plates are usually known as irises. In the arrangement shown in Figure 17-15(B), the irises are vertical and the plate assembly has an effect like a shunt inductance because the plates projecting into the region of greatest magnetic field effectively shorten the lines of magnetic force.

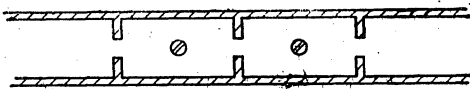

Fig. 17-16 - Two-Chamber Filter Iris-Coupled

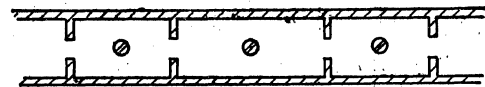

Fig. 17-17 - Cavity-Coupled Filter

CHAPTER 17 MICROWAVE RADIO SYSTEMS - GENERAL

freely. It should be noted that the energy of the rejected frequency band is not absorbed in the filter but totally reflected. Furthermore, the design is such that the reflections from the several shunts add in phase.

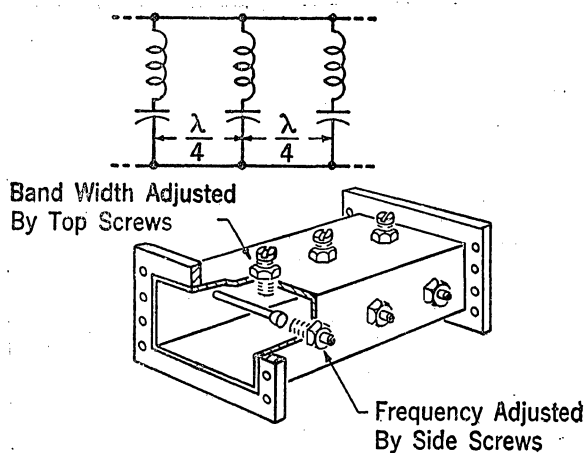

Fig. 17-18 - Band Reflection Filter

Duplexer

A device which is known as a duplexer, uses a number of the principles already discussed and has been employed to connect a transmitter and receiver simultaneously to the same antenna. With such a device energy received by the antenna is passed to the receiver without loss in the transmitter section. Likewise, energy from the transmitter section is passed to the antenna without entering the receiver.

One form of duplexer is shown in Figure 17-19A and B. Part of the functioning of this device is based upon the use of a resonant cavity which will be discussed in a later section. For the purposes of this discussion it may be considered as the equivalent of a parallel tuned circuit.

The oscillator tube may feed this cavity either through the use of an aperture or a coaxial probe. The cavity is then coupled to a T section through an iris window which transforms the combined impedance of the resonant circuit and the oscillator output circuit to match the waveguide section. The transmitter leg of the T is made one-half wave in length and is turned at the junction with a reactive stub to eliminate reflections as previously discussed.

Since the transmitter and receiver do not operate on the same frequency, the resonant cavity of the transmitter will appear as a short circuit at the receiving frequency. The half wave length of waveguide will transfer this short circuit to the main section, completing the side wall of the main waveguide and providing an uninterrupted path from the antenna

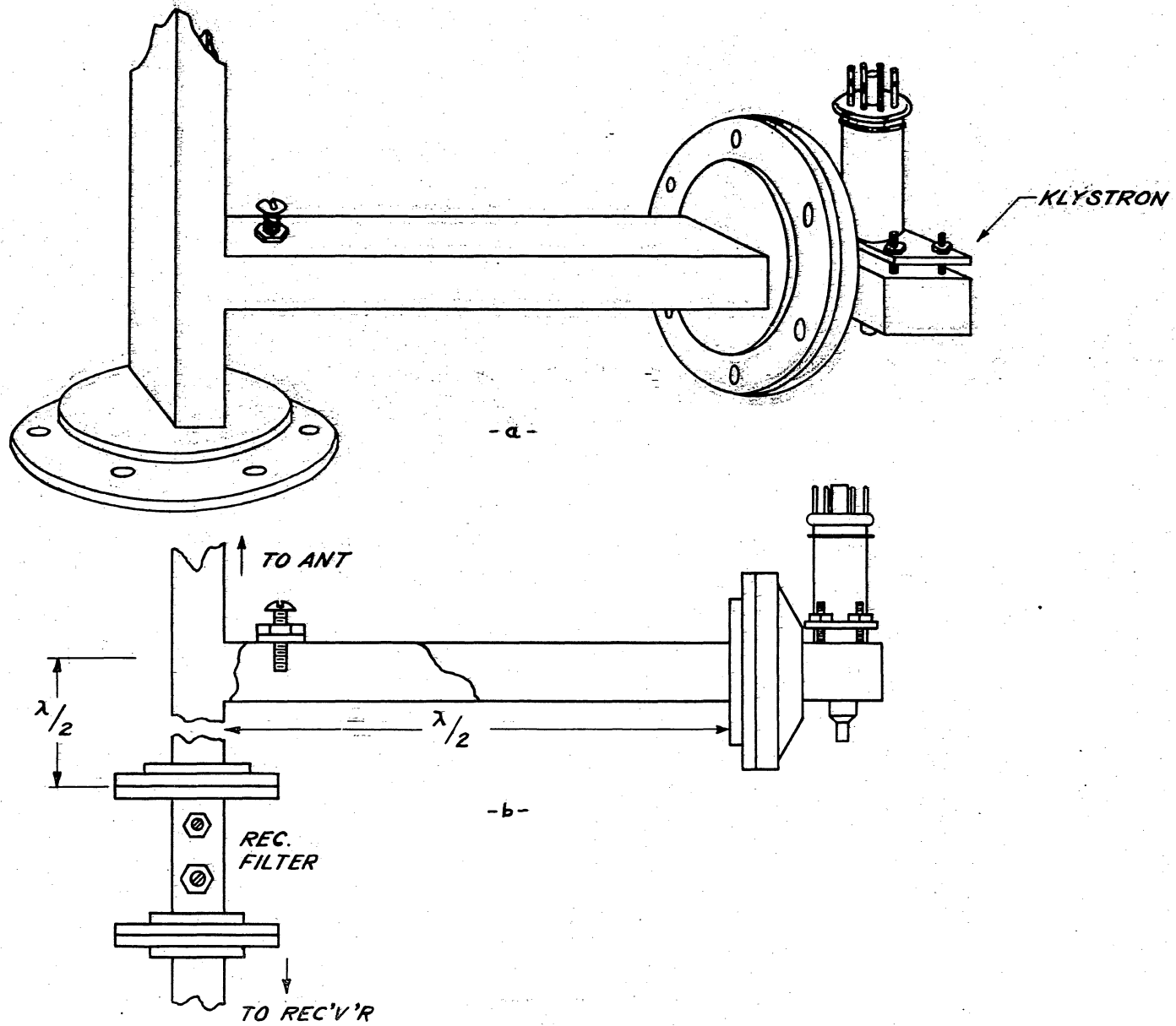

Fig. 17-19 Duplexer

CHAPTER 17 MICROWAVE RADIO SYSTEMS - GENERAL

to the receiver input. In the same fashion, the receiving filter appears as a short circuit at the transmitting frequency and since the receiving filter is a half-wave length from the junction, the short circuit will be transferred to the junction, completing the waveguide path from the transmitter to the antenna.

Since neither the transmitter nor the receiving filter short circuits are exactly zero impedance and since they will be located at a half wave length, within manufacturing tolerances, some reflection might occur at the junction. For this reason, the capacitive stub is placed in the waveguide to produce reflections in phase opposition and is adjusted to provide minimum standing wave.

Detectors and Mixers

As at the lower frequencies, microwave receivers follow the superheterodyne principle in order to obtain the benefits, both as to gain and bandwidth, to be derived from intermediate frequency amplification. The incoming microwave frequency is mixed with a local oscillator to produce an intermediate frequency in the general range of 65 to 75 megacycles. At this frequency suitable bandpass transformers may be used with conventional vacuum tubes to provide the necessary gain for the ultimate conversion into the original intelligence signal.

The most common mixing device presently used is the silicon diode which is diagrammed in Figure 17-20. A tungsten cat whisker pressing against a bit of silicon has the property of a rectifier, passing current predominantly in one direction only. Since a rectifier is electrically a non-linear device, heterodyning takes place and the difference between the RF signal and the local oscillator signal is used as the IF signal.

The use of a crystal at microwave frequencies is desirable only because of the large noise signals generated by vacuum tubes. The crystal also generates noise, but its signal to noise ratio is far superior to that of the best vacuum tubes developed so far. Two series of crystals are commonly used in the frequency ranges at which we operate. The 1N21 series is designated for an operating frequency of 3,000 mc while the 1N23 series is designed for the 10,000 mc range. The conversion loss of the crystals in these two series varies from 5-1/2 to 10 db, while the relative noise output varies from 1-1/2 to 4.

A practical form of first detector(or mixer)is indicated in Figure 17-21. The crystal is placed in the end of the waveguide in the same fashion that a probe would be placed and acts to terminate the waveguide and absorb the power which has been transmitted along the guide. Since the crystal with its associated filter circuits is not as high an impedance as a probe,

17.42

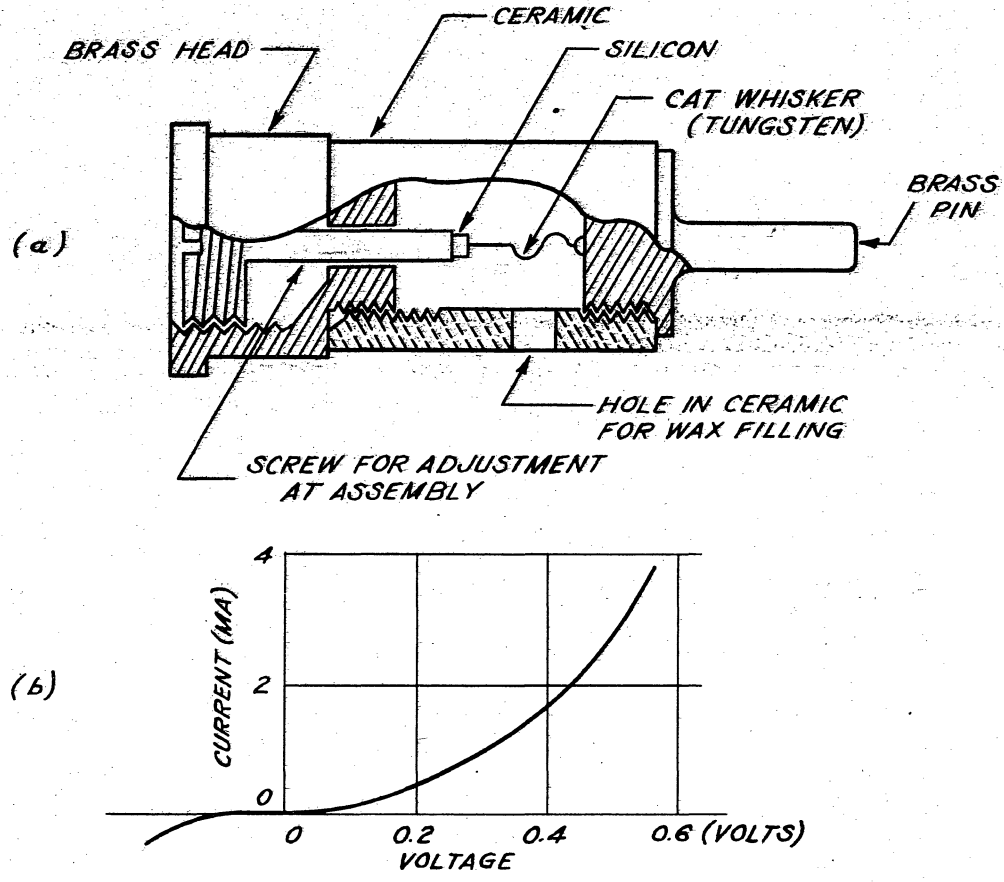
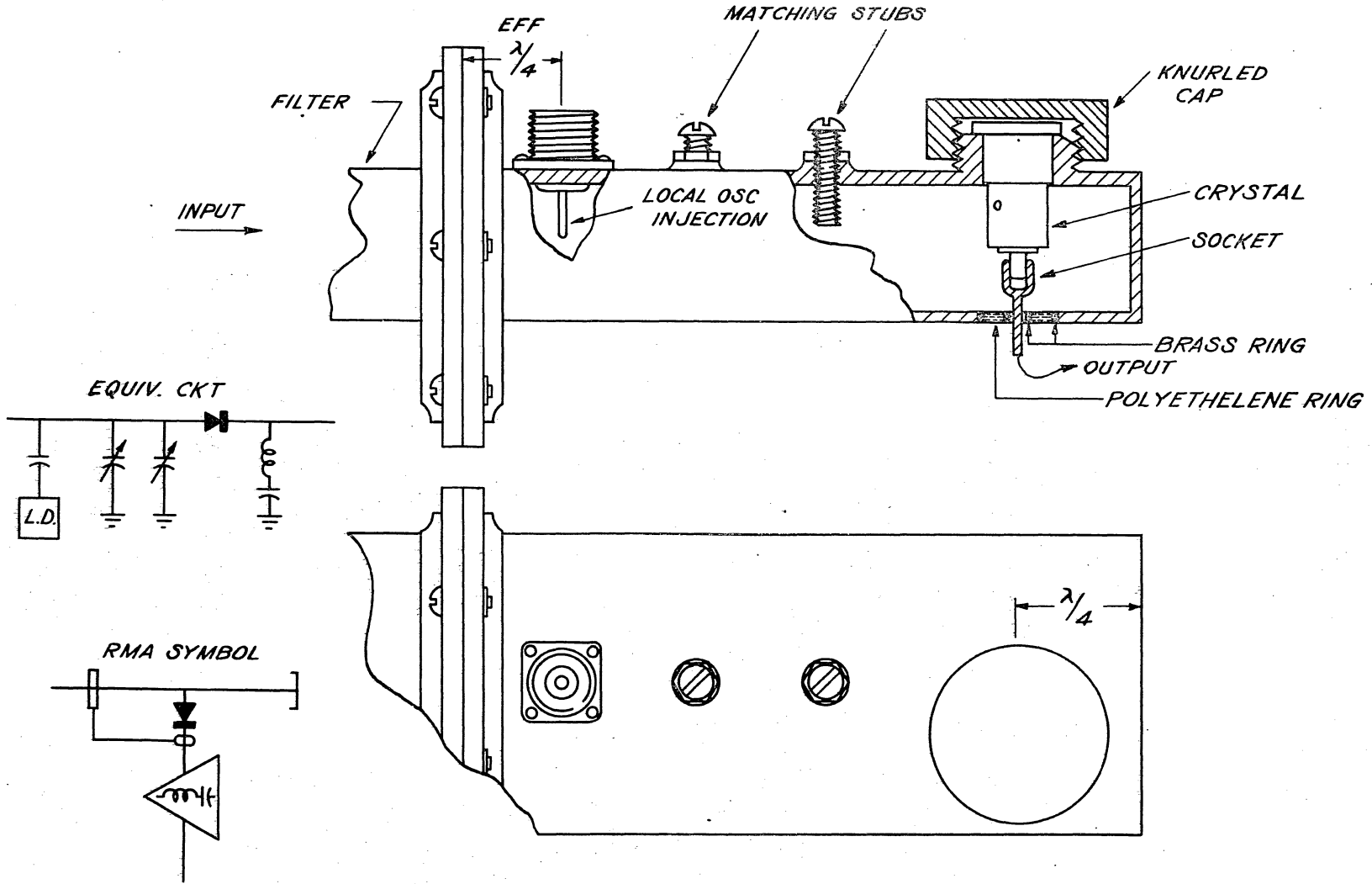

Fig. 17-20 Typical Silicon Diode



17.43

Fig. 17-21 Crystal Detector

CHAPTER 17 MICROWAVE RADIO SYSTEMS - GENERAL

it is not mounted in the exact center of the broad side of the waveguide, but is offset to provide a better impedance match. It is placed one quarter wave length from the end of the guide, however, in the same fashion as the probe.

The crystal mount consists of a collar in which the large end of the crystal is firmly seated and held in place with a screw cap to give firm electrical contact between the silicon element of the crystal detector and the waveguide. The tip of the crystal which is connected to the cat whisker inserts in a small jack arrangement on the opposite side of the waveguide. This jack is mounted on a polystyrene ring which serves to insulate the crystal output from the waveguide section. The polystyrene ring is mounted in a brass ring and has an inner brass ring which, with the outer ring, acts as an output by pass filter. The two rings with the polystyrene dielectric function as a capacitor electrically one quarter wave in length for the radio frequency signal. This entire arrangement causes the crystal holder to appear as a broadly tuned series resonant filter which effectively removes the RF signal and leaves the IF signal which is then fed into the first IF amplifier.

The radio frequency being passed down the waveguide from the receiving filter is at very low level, having sustained the path loss from the preceding station. As previously pointed out, the input filter prevents energy from the associated transmitter reaching the detector and causing damage to the crystal. The level at the crystal is thus kept low at all times since crystals of this type are prone to burn out if subjected to a high voltage.

Adjustable capacitive stubs are also provided in the waveguide section to match the crystal impedance to the waveguide impedance and prevent standing waves. The stubs are adjusted for minimum power reflected from the crystal at the operating frequency and are locked in position.

The heterodyning frequency of the oscillator is introduced into the waveguide by means of a coaxial type probe. This is located effectively a quarter wave length from the short circuit provided by the input filter, at the oscillator frequency, and is made adjustable so that the amount of injection voltage can be controlled. No tuning stubs are provided and no attempt is made to match the waveguide at the oscillator frequency since the level is high enough so that any losses due to mismatch are easily overcome.

Since energy from the input signal and from the local oscillator are both dissipated in the crystal, the usual modulation products will be developed and the difference frequency product is retained while the radio frequency products are prevented from leaving by the bypass circuit which forms a part of the crystal mounting.

17.45

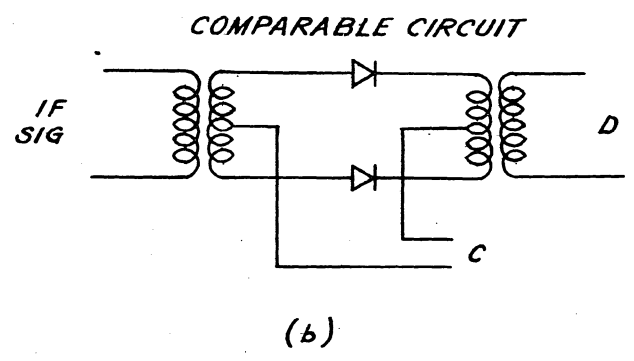
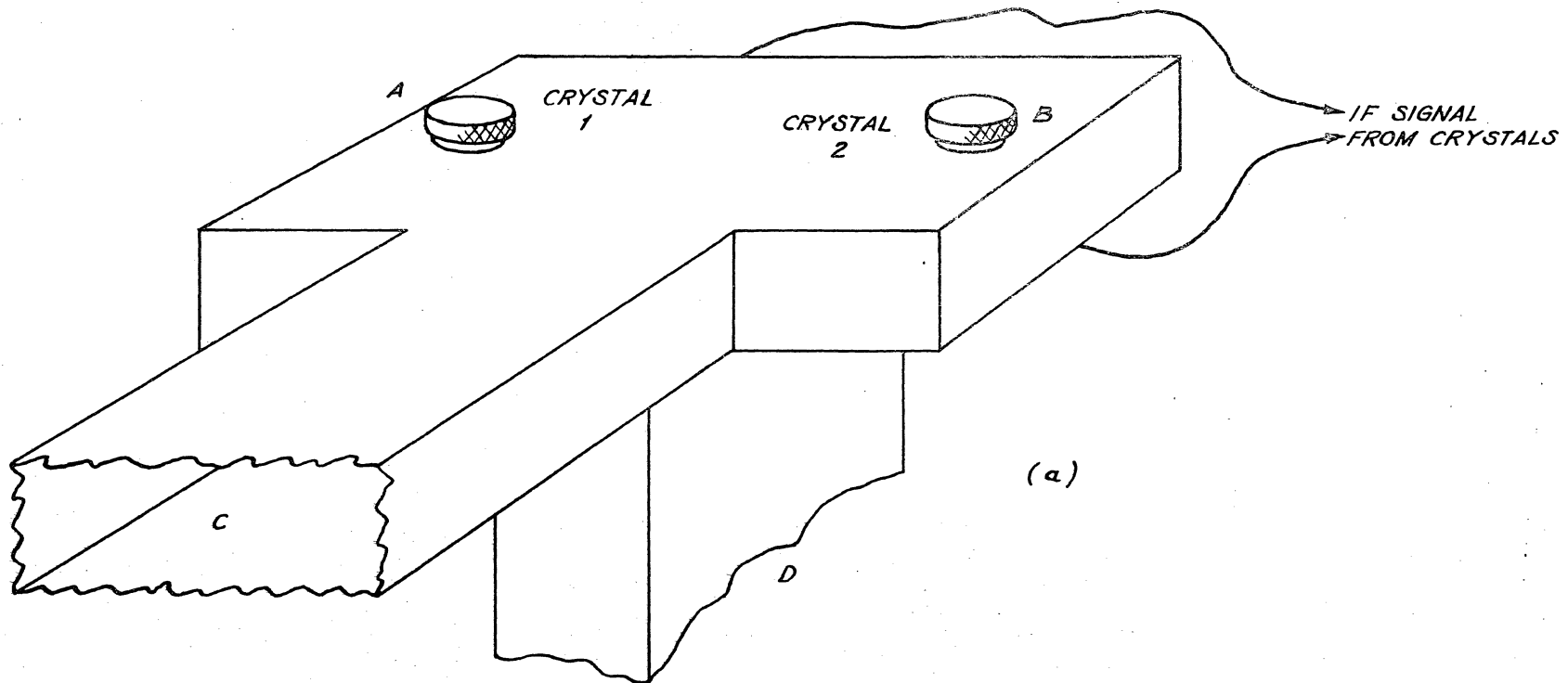

Fig. 17-22 Balanced Mixer

CHAPTER 17 MICROWAVE RADIO SYSTEMS - GENERAL

Another form of waveguide mixer or detector is shown in Figure 17-22. This arrangement makes use of a waveguide hybrid and operates electrically in a fashion similar to a balanced modulator (or balanced mixer) used at the lower frequencies and shown schematically in Figure 17-22B.

It will be seen from an examination of Figure 17-22A that energy entering the waveguide Section D will be polarized to pass through the T junction into Sections A and B. Sections A and B are terminated with crystals as previously explained in the case of the single crystal detector.

Energy entering the waveguide from Section C will likewise be polarized to enter Sections A and B and likewise be dissipated in the crystals. There will be no energy transfer between Sections C and D due to their difference in polarization.

The difference between the frequencies introduced into the waveguide Sections C and D is taken from the crystal detectors in the same fashion as in the case of the single crystal detector previously described. In the practical application of this type of mixer reactive stubs are provided in the "T" junctions to provide proper crystal-to-waveguide matching. Also, filters are provided in the output leads from the crystals to remove all radio frequency components and leave only the IF component which is passed directly to the IF preamplifier.

The preceding discussion has been on the basis that both units described would be used as mixers for demodulation. Actually it is possible to apply IF frequency to the crystals along with local oscillator to the waveguide and develop a modulated output by following the reverse reasoning to that employed above. Unfortunately the power handling capabilities of crystals of this type are limited and such a modulator would provide a very low output and would therefore require some form of microwave amplifier following it if any appreciable amount of energy were to be applied to an antenna.

In most cases of crystal mixer applications a direct current meter is placed in the IF crystal lead to read the rectified DC component of the IF signal. This permits a means of controlling the local oscillator level by adjusting the injection until a direct current reading is obtained which corresponds with the most efficient mixing level. The actual value of crystal current is determined by the design of the specific equipment and may fall in the range of 0.5 to 2.0 milliamperes.

Microwave Triodes and Amplifiers

Amplifiers for use at superhigh-frequencies (3,000 to 10,000 mc) present a number of special problems that require rather fundamental design differences. Chief of these perhaps is the fact that the transit time of the

CHAPTER 17 MICROWAVE RADIO SYSTEMS - GENERAL

electrons in the amplifier tubes becomes a matter of major importance at these extremely high frequencies. The adverse effects of transit time likely to be encountered in ordinary vacuum tubes can be overcome by the use of tubes of the klystron type. These tubes, however, are rather difficult to maintain. Furthermore, present designs of klystrons do not permit the use of more than a limited number of klystron amplifiers in tandem without cumulative noise and distortion becoming excessive.

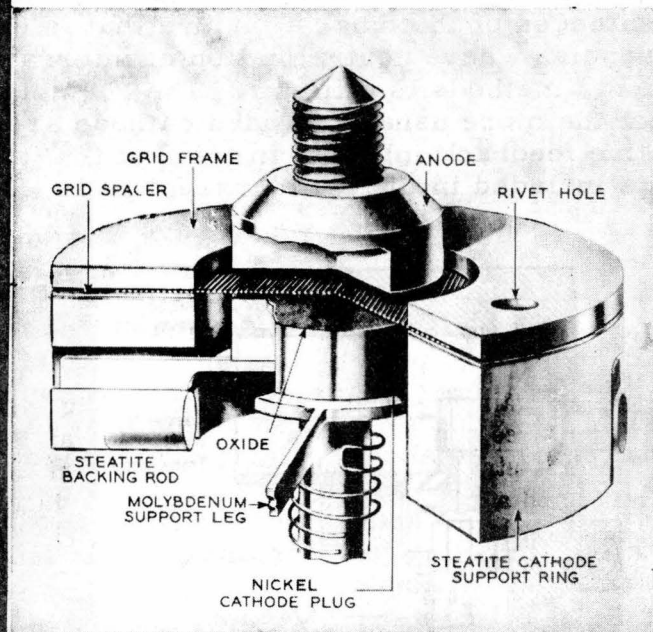
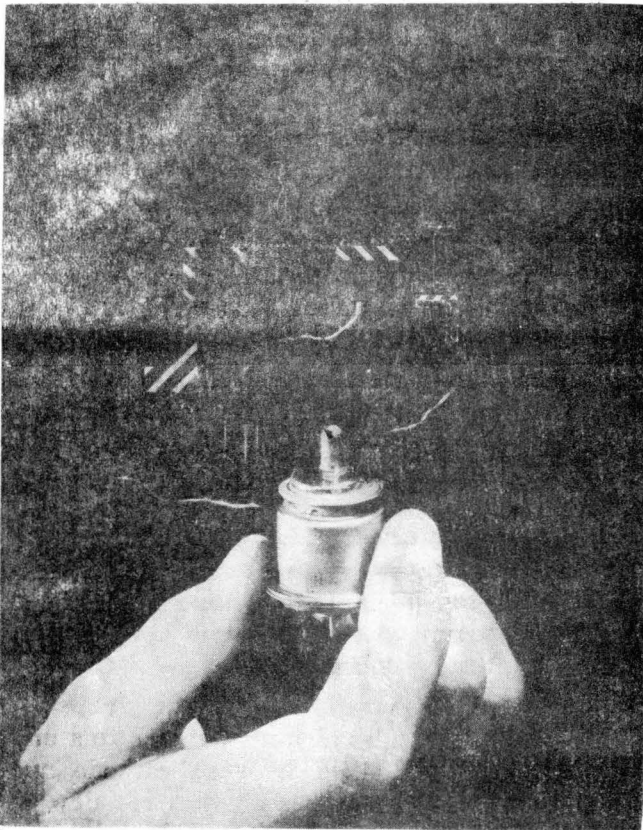

Fig. 17-23(A)

Microwave Triode

Fig. 17-23(B)

For application in very long radio relay systems requiring dozens of amplifiers in tandem, accordingly, a special tube (W. E. 416) was developed by Bell Telephone Laboratories. Because of the wide band of frequencies to be handled (at least 20 mc) this tube had to have very high transconductance. To overcome transit time limitations, the elements or electrodes of the tube also had to have extremely close spacing. Fortunately, these two requirements are compatible. The 416 tube is a triode of the so-called planar type, in which the elements are in

parallel planes, with the grid grounded to the frame of the structure. A perspective drawing (greatly enlarged) of the elements of the tube is shown in Figure 17-23. The oxide coating of the cathode is .0005" thick. The cathode-grid spacing is .0006". The grid wires are spaced a thousand to the inch and are .0003" in diameter. The plate-grid spacing is .012". The large number of very fine wires employed in the grid structure provides a close approach to a uniform electrostatic shield between cathode and plate, without interfering with the free flow of electrons. The transconductance of the tube is in the order of 50,000 μ mhos, the amplification factor is about 350, and the output resistance 7,000 ohms.

This triode always operates in a grounded grid circuit arrangement, where the input is applied between the cathode and ground and the output impedance is between the plate and ground. This automatically eliminates coupling between the output and input circuits through the inter-electrode capacitances of the tube, a feature that is especially useful at very high frequencies where neutralization of internal capacitance coupling by conventional methods is difficult. The possible gain, however, is less than that of the more usual grounded cathode arrangement because of the negative feedback inherent in the fact that the cathode to ground input circuit is included in the plate current path.

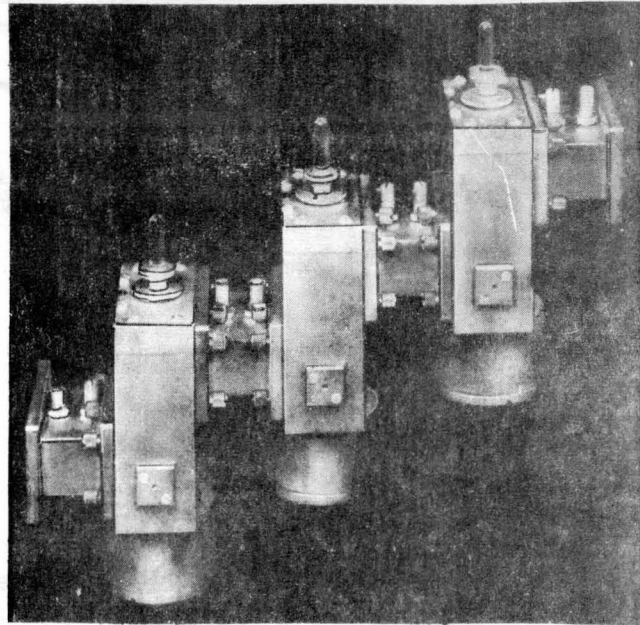
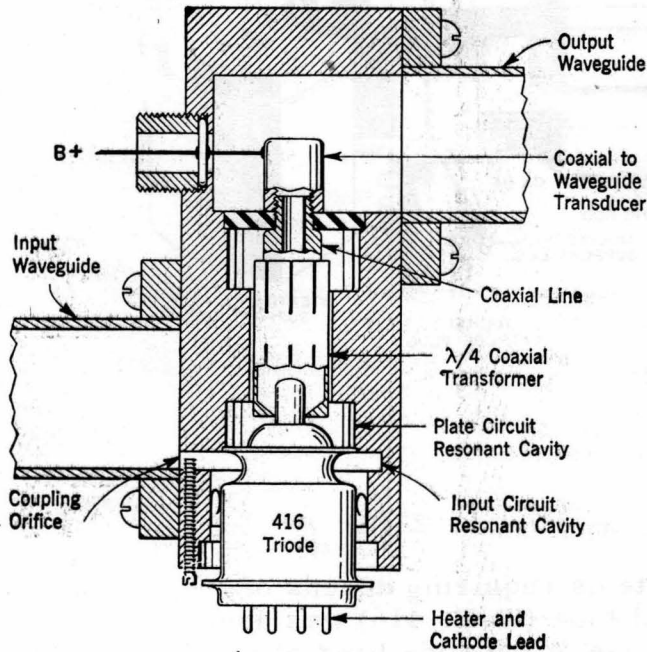

Three-Stage Microwave Amplifier

Fig. 17-24 (A)

Fig. 17-24(B)

CHAPTER 17 MICROWAVE RADIO SYSTEMS - GENERAL

Figure 17-24 shows one of these tubes connected in a waveguide "circuit." The input waveguide is coupled through an iris to an input cavity which may be tuned to resonance by a trimming screw across the opening. The grid separates the input cavity from a second resonant cavity of the plate or output circuit. This cavity transforms the plate impedance of the tube to a very low resistance (a fraction of an ohm). A quarter-wavelength coaxial line, which can be adjusted vertically to tune the output cavity, matches this low impedance to the impedance (about 45 ohms) of a short coaxial line leading to the transducer probe which extends into the output waveguide. Three tubes of this type are used in the transmitter amplifiers of the TD-2 microwave radio relay system. The three stages of the amplifier, which is illustrated in the accompanying photograph, are connected in cascade through waveguide tuners that effectively form double-tuned critically coupled transformers. The overall gain of the amplifier is normally adjusted to 18 db with an output power of 0.5 watt, although a somewhat higher gain is possible. The overall transmission characteristic is flat over about 20 mc between points 0.1 db down. As the output power of the close-spaced triode is increased, its maximum possible gain decreases. Accordingly, the gains of the three stages of the amplifier are not alike. The first stage has an output of about 80 milliwatts and a gain of about 9 db. The second stage output is about .25 watt with a gain of about 6 db, and the third stage output is about 0.5 watt with a gain of about 3 db.

Klystrons

A cavity type vacuum tube frequently used for microwave operation is known as the Klystron or the velocity-modulated tube and is shown schematically in Figure 17-25A. Two resonant cavities are placed longitudinally between a cathode and plate. These cavities have apertures or so called "grids" in their top and bottom surfaces, in line with the cathode and plate. The tube is usually operated with the plate grounded and a relatively high negative voltage applied to the cathode thus producing a stream of relatively high velocity electrons moving from cathode to plate. The entire assembly is contained within an evacuated envelope with suitable glass-to-metal seals at the surfaces of the resonant cavities.

An emission builds up between the cathode and plate, there will be a random variation in the cathode current over a wide range of frequencies and it is conceivable that some electrons will pass through the first cavity at the resonant frequency of the cavity. This will produce an oscillation in the cavity that will be sustained for several cycles. Let us assume that at a particular instant the cavity oscillation has made the side towards the plate positive and the side towards the cathode negative. The electrons leaving the cavity will be slowed down somewhat and attracted toward the positive surface. Electrons entering and passing through the cavity will likewise be speeded up and attracted by the positive side of

CHAPTER 17 MICROWAVE RADIO SYSTEMS - GENERAL

the cavity and a concentration, or bunch, of electrons will result. For this reason the first cavity is often referred to as the buncher and its surfaces as the buncher grids. As the bunch of electrons move toward the plate the polarity of the cavity reverses during the second half cycle of its oscillation. This again will produce a bunch of electrons near the cavity's surface next to the cathode.

As oscillation continues in the buncher cavity, a series of bunches of electrons will move down the tube, from cathode to plate, having a spacing determined by the resonant frequency of the buncher cavity. As these bunches strike the grids of the second resonant cavity they will give up their energy and produce and sustain an oscillation in the second or collector cavity. The electrons will then pass on and be collected by the plate as shown in Figure 17-25B.

If the collector or output cavity is now coupled to the buncher cavity with a section of coaxial cable, as indicated in Figure 17-25C, an oscillator will be produced since some of the energy given up in the output cavity will be returned to the buncher cavity in the proper phase relation to sustain oscillation. It is also possible to use this type of tube as an amplifier if energy is introduced into the buncher cavity and taken from the output cavity.

The resonant cavities themselves are usually arranged with some form of tuning device either in the form of slugs or compression devices which will change the physical spacing between the top and bottom surfaces of the cavities. Such cavities are usually rather broad in their frequency response and where a highly stable oscillator is desired an arrangement is used similar to that depicted in Figure 17-25D.

In this case the feedback loop has, in series with it, an invar cavity which can be made to have a very sharp frequency response and which retains a relatively constant physical size with wide changes in temperature. The amount of energy fed back is small in the case of most tubes of this type, and therefore that a Q of a very high value can be obtained.

Klystrons, currently being used, can develop an output power of as much as 3 watts at 6,000 megacycles with comparatively low plate voltages and with modest physical size. It is customary to manufacture tubes of this type with mica windows in the cavities so that direct connection to waveguide can be made. These windows retain the internal vacuum without obstructing the flow of electrons and are made of a size to provide the proper impedance match to standard waveguides. A rough sketch of a commercial type tube is shown in Figure 17-25E.

17.51

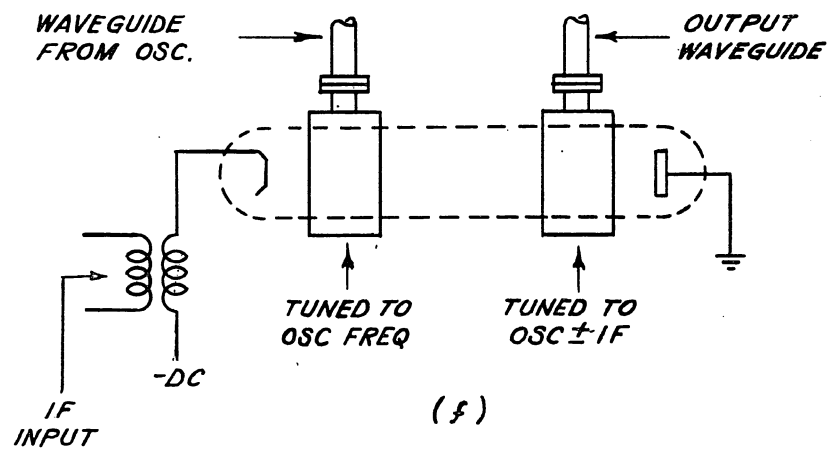
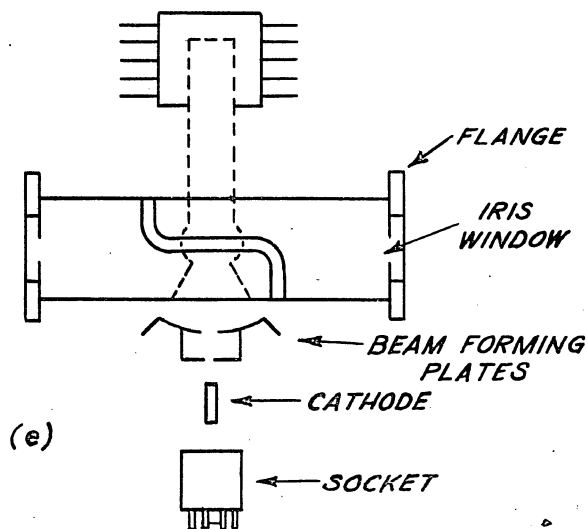
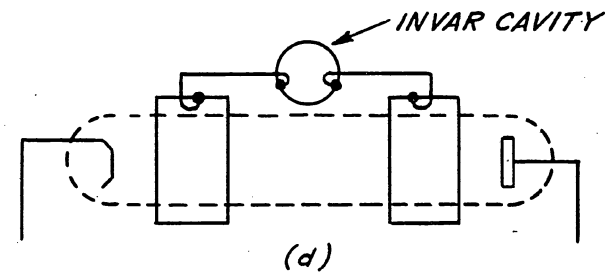
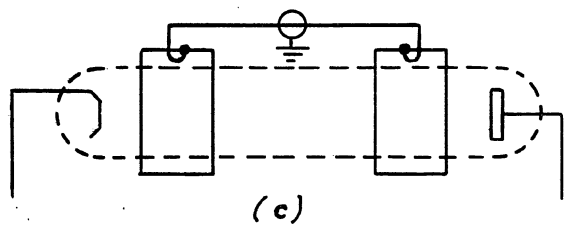
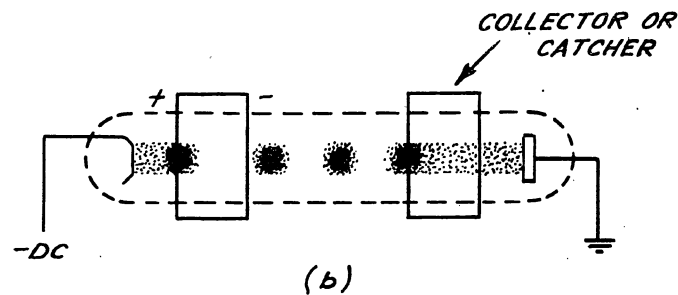
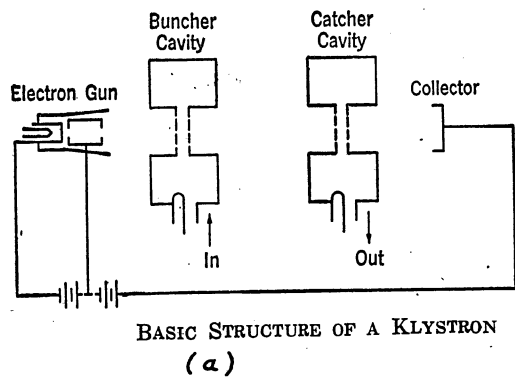

Fig. 17-25 Klystron Arrangements

CHAPTER 17 MICROWAVE RADIO SYSTEMS - GENERAL

In order to dissipate the heat produced by the plate current, the plate is usually made of a heavy solid piece of metal with radiating fins. The two cavities are closely spaced and terminated with flanges for waveguide connection. A heavy metal plate is provided with adjusting screws which can be used to deform the cavities and thus change their resonant frequency. These plates may be provided on top and bottom or on only one side. Emission is from a rather heavy cathode and the stream of electrons leaving the cathode are focused and directed through the grids of the cavities by beam forming plates which also act as accelerators. Power connections for the heater, cathode, and beam forming plates is usually made through an octal base of conventional type.

An application of the klystron developed by the Sperry Company and used in some of our equipments is called the synchrodyne mixer. In this application radio frequency is applied to the first cavity as shown in Figure 17-25F, and output is taken from the second cavity. This is the same arrangement that would be used for a klystron amplifier. Energy is then applied in series with the cathode at the intermediate frequency. This IF voltage will vary the plate-to-cathode potential of the klystron at the intermediate frequency rate and will therefore change the accelerating voltage on the bunches of electrons leaving the first cavity. This results in a form of phase modulation of the electron stream and by properly proportioning the potentials the modulation products are confined to the first sideband. The second cavity is then tuned to the frequency of either the upper or lower sideband as desired and used to feed the antenna. A means is thus provided for shifting from IF to RF frequency while permitting a high degree of oscillator stability since the oscillator loading is maintained at a constant value.

If the second cavity is removed from the klystron and the first cavity is made positive with respect to the cathode, electrons can be made to pass through the cavity at relatively high velocity and they will be bunched as before. If the plate is then connected to a negative voltage the bunches of electrons leaving the cavity will be repelled and returned toward the cavity and the positive potential. If the spacing between the cavity and the negative plate is properly chosen and the potential on the negative plate is properly selected the bunches of electrons returned to the cavity will be in phase with the original energy producing the bunches and sustained oscillation will result. Such a tube is known as a reflex klystron and is commonly used in microwave systems and microwave test gear. The "plate" of a reflex klystron is commonly known as a repeller or reflector. (Figure 17-26B)

The frequency of oscillation of a given tube can be varied over a considerable range by deforming the cavity to change its resonant frequency. This is illustrated in the view of a reflex klystron sketched in Figure 17-26A. By expanding or compressing the bow shown at the right of the

CHAPTER 17 MICROWAVE RADIO SYSTEMS - GENERAL

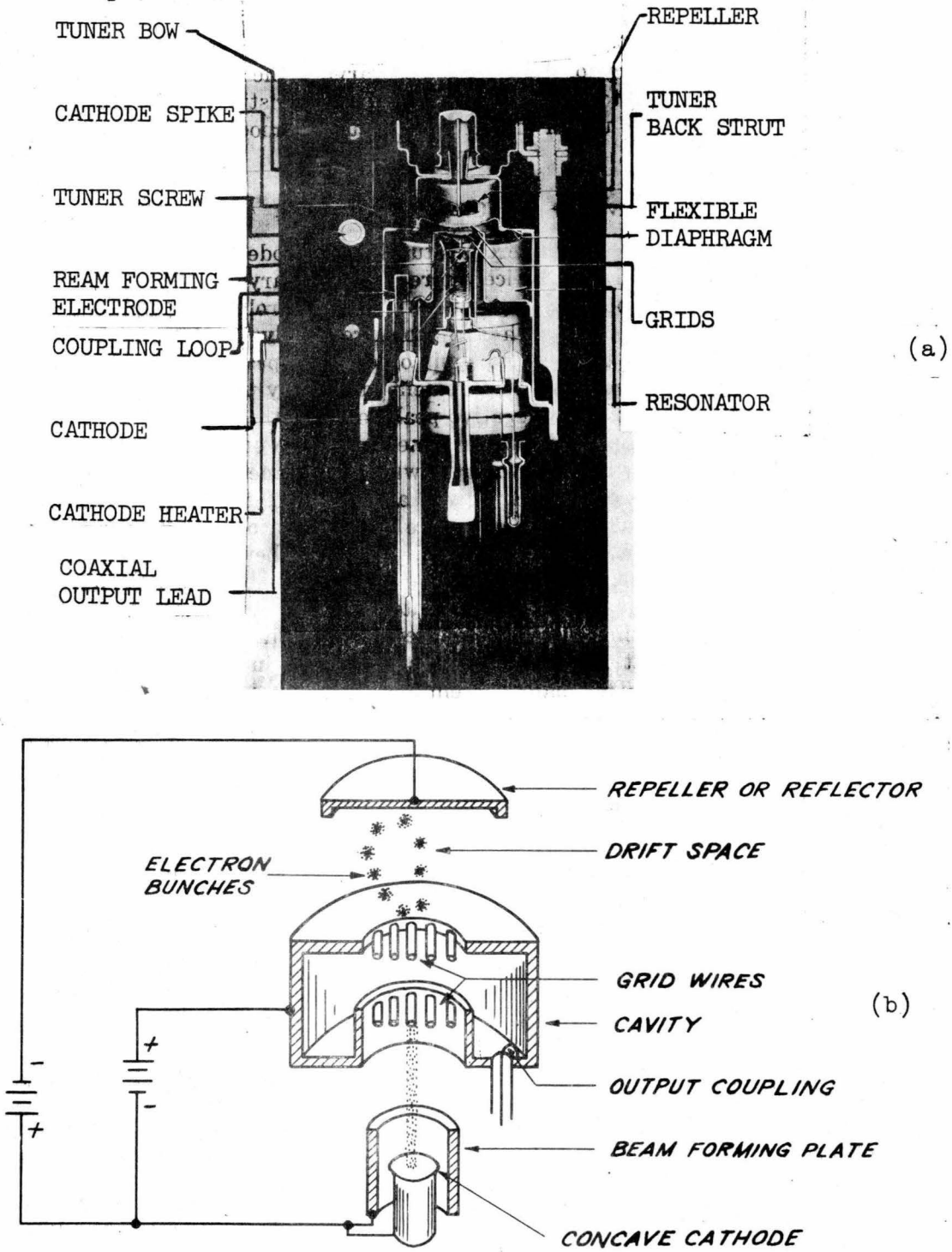

Fig. 17-26 - Reflex Klystron

CHAPTER 17 MICROWAVE RADIO SYSTEMS - GENERAL

last ten years have led to favorable chemical compositions and manufacturing procedures which permit materials with high permeability and low core losses.

Manufacture of the ferrites consists of mixing the raw materials, mostly paint pigments, so thoroughly that chemical combination progresses readily when the mixture is heated to firing temperatures. The mixture is poured into forms and compressed in a hydraulic press before firing. This insures that the final body will be chemically reacted and bonded into a ceramic solid. Since the ferrites are too hard to be cut with steel tools after firing, core designs are made simple; of a form easily pressed in economical dies; and such as to require minimum subsequent grinding. The ferrites used for microwave application are of a non-permanent magnet type and are used as the cores of electromagnets in which the magnetic field can be controlled by the amount of current passed through the winding about the core.

It can be shown that when a magnetic field is properly oriented with respect to a radio wave the polarization of the wave can be rotated. By placing a piece of ferrite in a waveguide it is possible to rotate the plane of polarization as the electromagnetic wave presses the ferrite. By controlling the magnetic field of the ferrite with the DC current through the energizing coil the amount of rotation of the polarization of the wave can be controlled.

One of the first applications of a ferrite to a waveguide has been called an isolator. In Figure 17-27A a linearly polarized wave is coupled into a circular pipe containing a piece of ferrite magnetized along the axis of the pipe, forming the isolator. At the other end of the circular guide is a second section of rectangular guide which is rotated 45° with respect to the first section of guide. By a suitable choice of ferrite dimensions, and applied field, the wave travelling from left to right is rotated 45° and so travels freely through the rectangular section of waveguide at the right hand end. A wave entering from the right hand end will also be rotated 45° and will arrive at the left hand end polarized at 90° to the rectangular waveguide so that it cannot be received. A polarized absorbing vane is placed at the end of the circular section to absorb this polarization selectively. Therefore, a wave entering the structure at the right and travelling from right to left is totally absorbed by the polarized absorber and is not transmitted. The result is a one-way transmission device.

A variation of this device has been called a circulator. By coupling additional rectangular waveguides to the circular section as shown in Figure 17-27B the polarization previously absorbed by the resistive vane can be taken out. Now it will be seen that a wave entering at A is rotated through 45° so as to emerge at B. A wave entering at B is further rotated and emerges at C. Likewise, C couples to D and D to A. One can place a

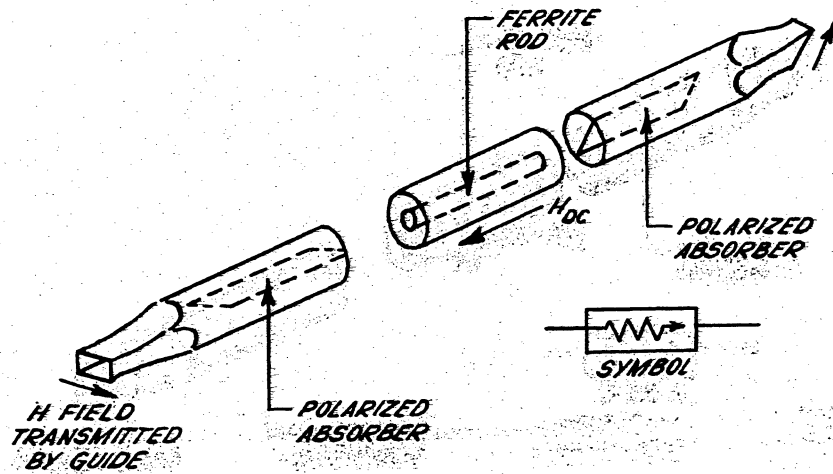

a - ISOLATOR

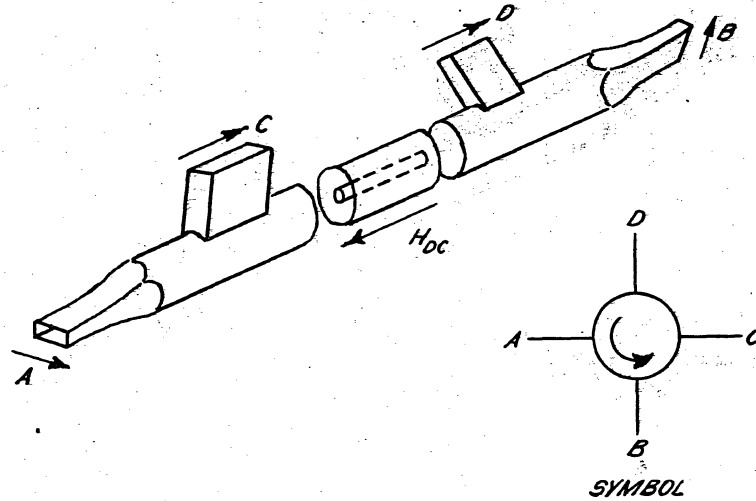

b - CIRCULATOR

Fig. 17-27 Ferrites

CHAPTER 17 MICROWAVE RADIO SYSTEMS - GENERAL

transmitter at A, an antenna at B, a load at D, and a receiver at C, and simultaneously receive and transmit on the same antenna with crosstalk limited only by the degree to which the antenna is reflectionless. The load at D serves the purpose of absorbing any power which may be reflected from the receiver at Terminal C.

A form of modulator can be devised, using the isolator of Figure 17-27A, by varying the field from the previously assumed value through zero to an equal value in the opposite direction. This variation of the field in the ferrite will produce a rotation which will vary from $+45^\circ$ to -45° and the transmitted power will vary from 100% to zero. In actual practice the minimum transmitted power is down about 50 db (0.001%). Here then is an electrically controlled attenuator which becomes a modulator if the field is varied at the modulation rate. This permits amplitude modulation, without frequency modulation, from such tubes as Klystrons which have not previously been useful for other than frequency modulated outputs. Many other applications of ferrites to microwave transmission are possible and have been tried, however, the above will serve to illustrate the basic principles concerned.

Travelling Wave Tubes

In Figure 17-28A the solid lines are assumed to represent the lines of electric field in a wave travelling from left to right. The wave is travelling in an undefined cylindrical space at a velocity of propagation that is less than the velocity of light by ten or twenty times. The method by which the velocity of the wave has been slowed down in immaterial at the moment. Through the center of the cylinder, represented by the dotted area in Figure 17-28A, is assumed to be flowing a stream of electrons. The electrons are travelling at the same velocity as the wave.

Initially the electrons flowing through the field will be evenly distributed as in Figure 17-28A. However, some of the electrons as at a. in Figure 17-28A are in retarding fields while others, as at b., are in accelerating fields. As a result the electrons will be speeded up or slowed down and tend to congregate in alternate regions of zero longitudinal electric field as shown in Figure 17-28B. The average velocity has not been changed because as many electrons were slowed as were speeded up. Therefore, once this bunched condition has been achieved no further changes will take place and the beam and the wave will travel together in this configuration.

If now the electron beam is speeded up or slowed down a little the bunches can be changed in phase relative to the wave so that they will always lie in either a retarding or an accelerating field. If the bunches always lie in a retarding field they will be continually losing energy and this energy is given to the wave. The result is an increase in the wave amplitude and the device which results is actually an amplifier.

If the electron beam is faster than the wave the electrons will be moving past the wave from left to right in Figure 17-28A at a slow rate. As the electrons move through the wave pattern they are alternately speeded and slowed by the electric field. In the regions a. in Figure 17-28A they move more slowly. In the regions b. they are speeded up and move rapidly. The electrons are thus bunched in the regions of slowest motion or at every point of retarding field. The electrons will, therefore, spend a long time in the regions of retarding field and a comparatively short time in the regions of accelerating field. For this reason more energy is lost to the wave than is gained back. The wave is continually growing in amplitude and the beam is being continually slowed. An amplifier that operates in this fashion is called a travelling wave amplifier.

To build a practical amplifier it is necessary to find a way of slowing a wave to a velocity that can be approximately matched by an electron stream. One way of doing this is shown in Figure 17-28C. A straight conductor is coiled to form a helix and placed inside a waveguide. Forming the helix does not alter the distributed capacitance particularly but does increase the inductance of the conductor. This is equivalent to loading on a voice frequency conductor and increases the phase constant. The phase velocity for the line is, therefore, reduced and can be reduced by any amount merely by winding a tighter coil. Besides being slowed the wave field in the waveguide is modified and there are fields both inside and outside the helix. The field inside is very similar to that shown in Figure 17-28A.

To make a complete amplifier tube an electron beam is provided down the center of the guide and a means for applying and removing energy from the ends of the interaction space as shown in Figure 17-28D. In a tube of this type there will generally be a reflected wave from the helix in the input and another reflected wave from the output guide on the helix. The first reflection, if kept small, will do no particular harm but the second wave which is travelling backwards along the helix can cause the tube to oscillate if sufficient precautions are not taken.

Assume that the voltage gain of the tube is 100 times and that 10% of the field is reflected back from the output waveguide. If we assume that the helix is essentially lossless we will have the full amount of the reflected power transmitted back to the input end of the tube. There will be no appreciable interaction with the electron stream because the beam and wave are travelling in opposite directions and any effect of one on the other will average out. At the input end of the tube the wave is again reflected and let us assume that 10% is the amount effectively reflected. 1% of the output wave is thus now travelling down the tube in the proper direction for amplification but 1% of the output is just equal to the input if the gain is 100. It is apparent that this is sufficient to produce oscillation.

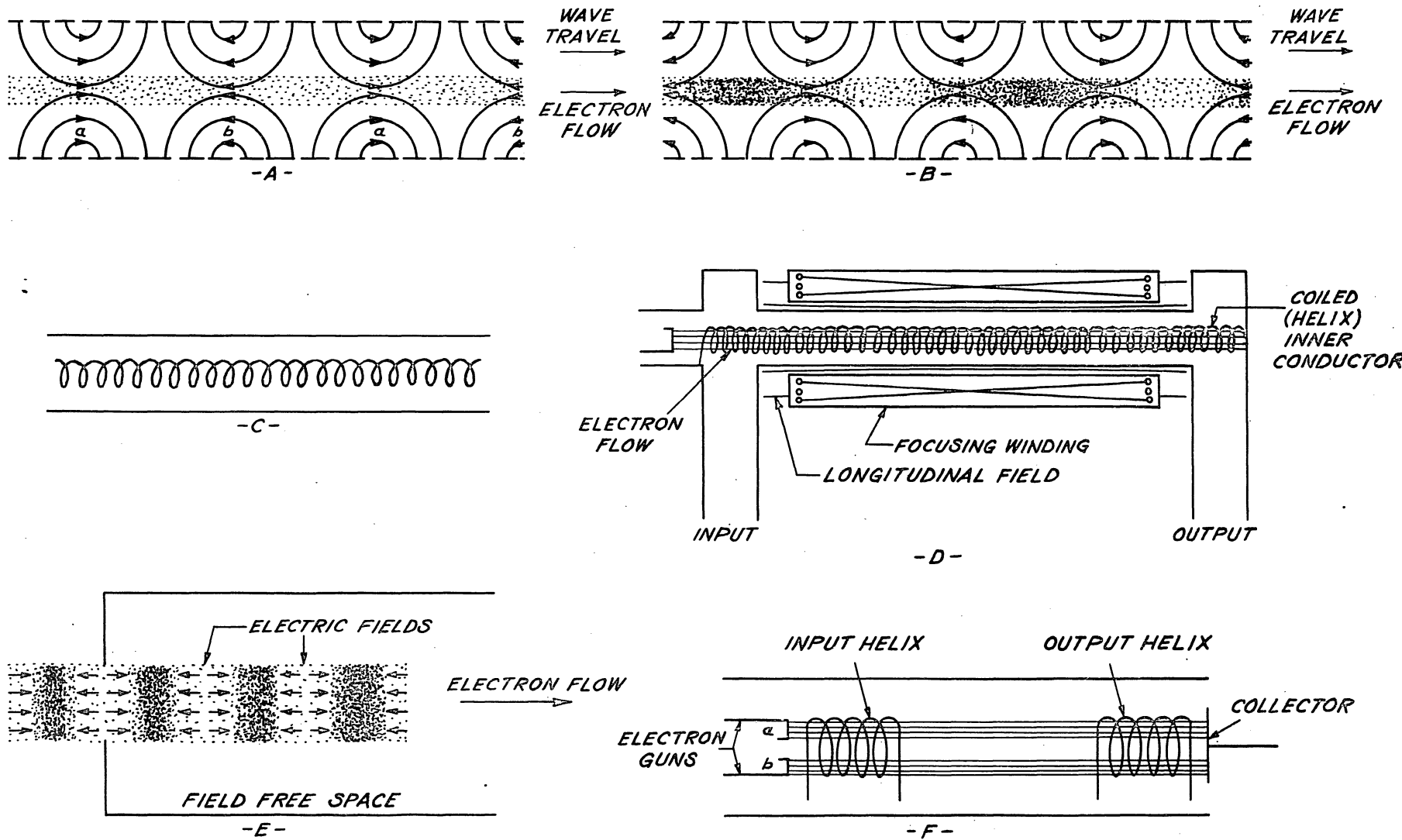

Fig. 17-28 Traveling Wave Tubes

CHAPTER 17 MICROWAVE RADIO SYSTEMS - GENERAL

This effect is made use of in the backward wave oscillator. To avoid oscillation in a practical tube a combination of low reflection and lossy line may be used.

If we refer to Figure 17-28B we see that the bunched electrons are in regions where there is a weak field tending to spread the beam sidewise. Also the electrons in the beam repel one another. If suitable action is not taken the beam will eventually be drawn out to the sides of the waveguide. To avoid such an occurrence in a practical tube focusing action is utilized. This can be done by providing a longitudinal magnetic field of constant magnitude as shown in Figure 17-28D. The field is along the direction of the electron or current flow. As the beam tends to spread a flow of electrons (or of current) will be crossing the magnetic field. The lateral force of the magnetic field will, however, cause the electrons to be forced back into the beam thus counteracting the effect of the electric field. This is the same action that occurs in a motor when a current-bearing conductor is placed in a magnetic field.

A second form of travelling wave tube is the double-stream amplifier. In the travelling wave tube a special transmission line that would pass an electromagnetic wave was required. This line was such that the electromagnetic wave was approximately matched in velocity to the velocity of a stream of electrons. It is possible to replace this waveguiding structure with another electron stream.

In Figure 17-28E is shown a stream of electrons from an electron gun directed into a field free region. This stream of electrons has been density modulated. In examining the field along the axis of the beam it will be seen that the electric field variation is the same as that in Figure 17-28B. The arrows in Figure 17-28E show the direction of the electric field. Thus a wave is travelling with the beam and at the same velocity as the beam. If a second beam is projected down the same space it might be reasonably expected that somewhat the same action would take place as in the travelling wave tube just described. Actually such action does take place, however, the actual action is much more complex than the simple analogy just used. The basic components of a simple two-beam amplifier are shown in Figure 17-28F. The two electron guns provide beams of differing velocities. An input helix is used for coupling to the beam and an output helix is used for coupling from the beam. These two helices act as short travelling wave tubes, however, they serve primarily for coupling and contribute very little to the overall gain of the tube. The main amplification takes place in the space between the two helices. The double-beam tube eliminates the need for a waveguide structure and reduces the electron tube amplifier to its bare essentials: a vacuum envelope and a stream of electrons.

CHAPTER 17 MICROWAVE RADIO SYSTEMS - GENERAL

Both the travelling wave tube and the double-beam tube can be constructed to operate over a wide band of frequencies, since the interaction space in which the gain is realized is essentially a transmission line and the waves on this line can exist over large frequency ranges. The power gain in a typical travelling wave tube is 10,000 and the bandwidth is 600 mc centered at about 3,000 mc. Thus the product of gain and bandwidth is greater than any of the other existing microwave amplifiers. The efficiency of present travelling wave tubes, however, is only in the order of 10 to 15 percent.

17.11 ANTENNAS

The effectiveness of a transmitting antenna is measured by its ability to convert a maximum amount of the power developed by a radio transmitter into radiant energy in the form of electro-magnetic waves, which will be transmitted in such a direction as to produce maximum field strength at the receiver. In point-to-point transmission, and to some extent in broadcast transmission, the factor of major importance is usually the degree of directivity or antenna gain that can be secured. Transmitting and receiving antennas are sometimes alike but there are many situations where economic considerations and other factors require quite different designs for the two conditions.

There are many different antenna designs and arrangements in practical use in radio work. The various designs may be grouped into a limited number of major types, however, in which the controlling design factors are the frequency range in which the antenna is to operate and the degree of directivity desired. In general, antenna effectiveness can be more economically increased as the frequency of the radio wave is increased.

Transmitting antennas for medium radio frequencies quite commonly employ a simple vertical radiator which may consist of a single wire or a slender steel tower. Such radiators are tuned to resonance for the carrier frequency to be transmitted by making their total height equal to an appropriate fraction of the carrier wavelength; or, if the wavelength is too long to make this practicable, by adding lumped reactance in series with the radiator at its top (capacitive) or base (inductive). In either case, the antenna when energized at its resonant frequency, behaves like a resonant transmission line with a standing wave of current extending along the conductor.

The typical radio broadcast antenna is a steel tower slightly more than one-half wavelength in height and effectively grounded at its base where the energy is applied.

For radio transmission in the very high and ultrahigh-frequency ranges, the basic form of antenna is a half-wavelength resonant wire commonly known as a half-wave dipole.

CHAPTER 17 MICROWAVE RADIO SYSTEMS - GENERAL

Radiation of electromagnetic energy in the super-high frequency range involves principles and methods that are analogous to, if not identical with, those of light transmission. Antennas used at these frequencies may be grouped under the general designation of aperture radiators. Their basic function is to transform the spherical wavefront, which is normally developed from a point source of radiation, to a plane wavefront. To the extent that this is accomplished, the radiated energy may be projected in a very narrow beam in the desired direction. In microwave practice, antenna gains in the order of 30 to 40 db are commonly obtained.

One method of obtaining a directive plane wavefront employs the optical technique of a parabolic reflector comparable to that of the ordinary searchlight. The geometrical characteristics of the parabola are such that waves emanating from a point source at the focus will be reflected in parallel straight lines that will all reach the plane of the mouth of the parabola at the same time. If, as illustrated in Figure 17-29, an auxiliary reflecting surface is placed in front of the energy source to prevent any direct radiation, all of the energy will be reflected from the paraboloid and will appear as a plane wave across its mouth. Since, as has already been pointed out, electromagnetic energy can escape directly from the open end of a waveguide, the same effect can be produced by means of a waveguide leading to the focal point of the parabola with its open end turned back to direct escaping energy toward the reflecting surface, as illustrated in Figure 17-30. A plane wavefront across an

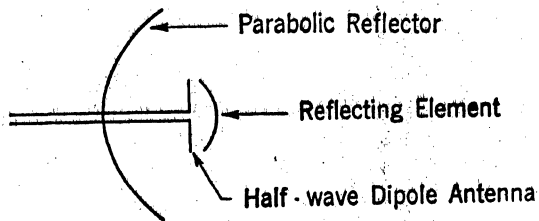

Fig. 17-29

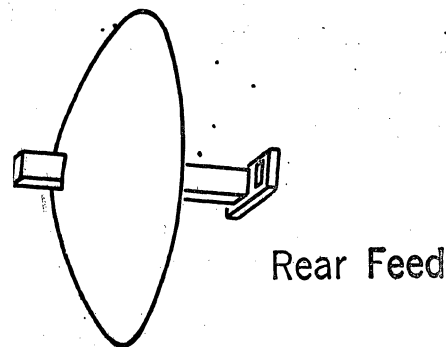

Fig. 17-30

aperture may also be attained by simply flaring out the end of a waveguide to form a long horn in which the fields in the guide can expand gradually to produce a uniform field across the mouth of the horn. To accomplish this result, however, the flare angle of the horn must be small and an aperture comparable in size to that of the parabolic reflector could only be reached with a horn that would be too long to be practicable. In the major Bell System radio relay systems (TD-2), this difficulty is overcome by using

CHAPTER 17 MICROWAVE RADIO SYSTEMS - GENERAL

a comparatively short horn having a high flare-angle but with a "lens" across its mouth that acts like an optical lens to produce a plane wavefront. This arrangement, known as a delay lens antenna, is illustrated in Figure 17-31. As indicated there, the lens cross-section is of plano-convex form and is placed at the mouth of a pyramid-shaped horn in a housing 10 feet square and 3 feet deep. The effect of the lens is much the same as that of a plano-convex lens on the transmission of light.

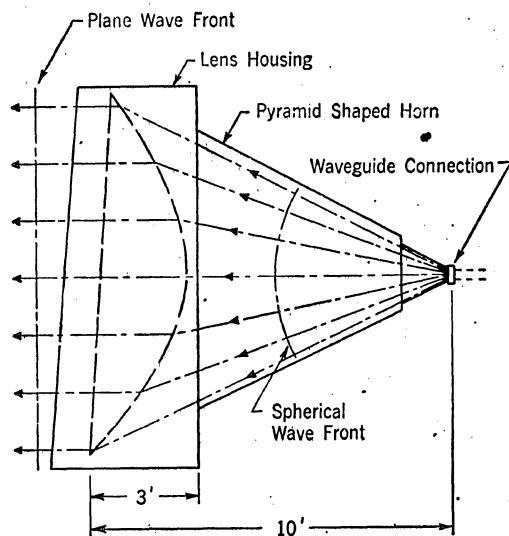

Fig. 17-31 - Delay Lens Antenna

Superhigh-frequency radio waves coming from the waveguide connected to the rear of the horn diverge, as indicated by the arrowed broken lines, to form a spherical wavefront. When they reach the lens, however, the velocity of the rays near the center is decreased enough by the thicker lens structure at that point to cause delay equal to the time required for the outer rays to traverse their geometrically longer path. All of the rays accordingly reach the front of the lens at the same time and proceed in the parallel paths of a plane wavefront. The entire lens is tilted back slightly, as shown in the Figure. This is done to prevent any energy that might be reflected from the face of the lens from being focused back to the waveguide outlet. This lens, although its action is very similar to that of a glass lens, is actually made up of a very large number of narrow aluminum strips held in place by slabs of foamed polystyrene. The effect of these metal strips is essentially the same as that of the molecules of a glass lens in retarding light waves.

CHAPTER 17 MICROWAVE RADIO SYSTEMS - GENERAL

To relieve congestion in the 4,000 megacycle band, development work has progressed on a 6,000 megacycle microwave system and consideration is also being given to operation in the 11,000 megacycle band. To further relieve congestion it is desirable to use cross-polarization of the signals on adjacent channels, i. e. placing the electric vectors of the fields of adjacent channels at right angles. To derive all these benefits the horn reflector type of antenna has been developed and is now being used on all new microwave installations.

The horn reflector antenna, coded KS-15676, is capable of simultaneously transmitting horizontally and vertically polarized signals in the 4,000, 6,000 and 11,000 megacycle common carrier bands with good transmission characteristics. Basically, the antenna is very simple and consists of a large horn feeding a section of a parabolic reflector. Although having a smaller aperture the gain at 4,000 megacycles is approximately the same as that of the delay lens antenna previously discussed. The general physical arrangement of the antenna is indicated in Figure 17-32.

Circular copper waveguide will be used with the horn reflector antenna to permit transmitting simultaneously signals of both polarizations in the three frequency bands. In addition to handling this entire range of frequencies and polarizations the circular waveguide has a lower transmission loss than the rectangular guide previously used. At 4,000 megacycles the loss is approximately one-half that of a rectangular guide.

It is possible to use a flat, smooth surface to redirect a beam of microwave energy in the same fashion that a mirror might be used to redirect a beam of light. An antenna can be placed on the ground, aimed to radiate vertically, and the radiation redirected horizontally by means of such a reflector. The reflector may be mounted on a tower or other antenna supporting structure instead of the conventional antenna. This arrangement eliminates the cost of waveguide as well as the loss of the waveguide which would be required up the tower and permits placing the antenna close to the transmitter. Thus when a modulated oscillator, such as a reflex Klystron, is used non-linearities due to oscillator loading are kept at a minimum.

In Figure 17-33 is shown a reflector mounted at an angle of 45° . The reflector is assumed to be plane, with an elliptical shape, such that when placed at 45° to the vertical the projected reflector area is circular, both horizontally and vertically. The diameter of the projected circle is $2R$. An antenna is placed below the reflector having a diameter of $2A$. This antenna is assumed to have an aperture field which is plane, circular symmetric, with maximum field at the center. The incoming energy is assumed to be a uniform plane wave of value E_0 . If the reflector intercepts this uniform plane wave, the diffracted wave behaves as would light

17.66

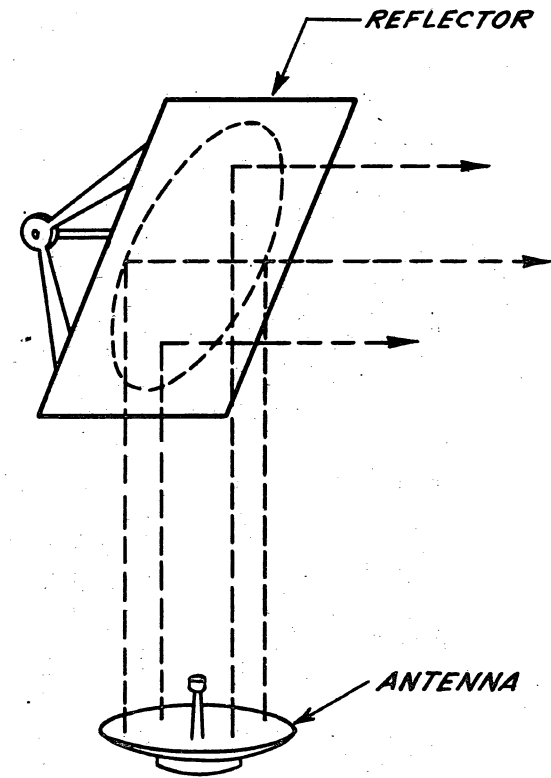
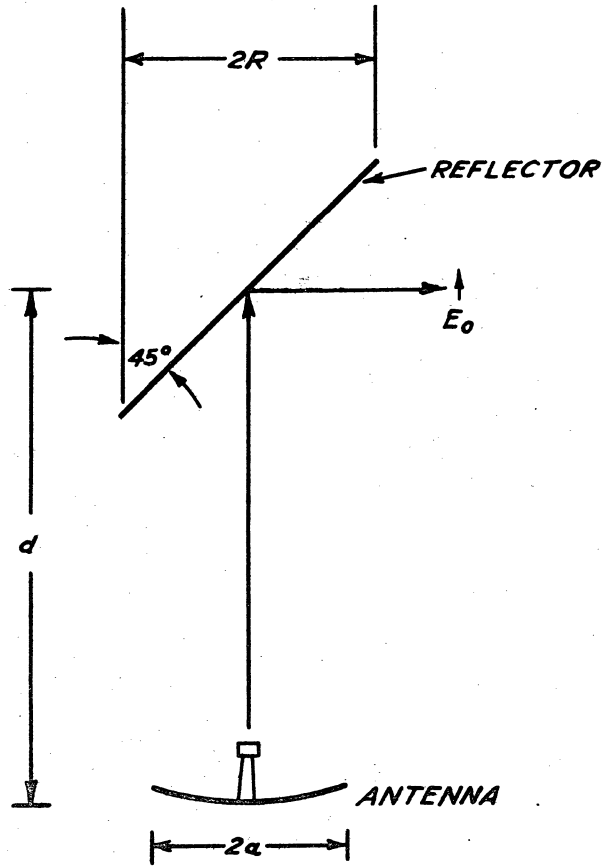

Fig. 17-33 Plane Reflector

CHAPTER 17 MICROWAVE RADIO SYSTEMS - GENERAL

that had passed through an aperture in a perfectly absorbing screen. The area of the aperture would be equal to the projected area of the reflector. This results in what is known as Fresnel diffraction and the aperture field is divided into Fresnel zones. The distribution of the field intensity over the antenna aperture will be circularly symmetric but will vary along any radial from the center of the antenna to the edge. Also there will be a variation in the cross sectional distribution of field intensity with distance between the reflector and the antenna. Due to this focusing effect, under the reflector, the energy received by an antenna at ground level may be more than the energy which would be received by the same antenna were it mounted in place of the reflector. Practical gains of about 2-1/2 db are quite feasible with reasonable reflector and antenna sizes and reasonable spacing between the antenna and the reflector. The reflector size must, of course, be kept large in relation to the antenna size to assure that as large an area of the wave front will be intercepted and reflected to the antenna as would have been intercepted by the antenna had it been located in the direct beam, instead of the reflector.

CHAPTER 18

TD - RADIO SYSTEMS

18.1 INTRODUCTION

Radio systems as used in intertoll plant are a type of line facility. They serve as an alternative to physical lines such as open wire, cable pairs, or coaxial tubes. Like coaxial tubes, radio systems are one-way facilities. Therefore, twin systems must be used to accomplish transmission in both directions.

Several types of microwave equipments have been used in providing Bell System radio relay service. The original Long Lines installation for toll use was between New York and Boston and used what was then coded the TDX equipment. This system operated in the 3,700-4,200 megacycle frequency band and provided wide band communication channels suitable for television or multi-channel telephone service. From experience with this system the TD-2 system was developed and this now forms the backbone of our present coast-to-coast radio relay network.

Under our present radio system coding the "TD" designation indicates a super high frequency, broadband, relay system. The TD-2 system is a highly refined transmission facility which can accommodate an ultimate of 24 channels although only 12 channels are currently being used. Each channel has sufficient bandwidth to accommodate a full L carrier terminal or a 4.5 megacycle television signal without undue distortion.

The new system, TD-3 is a solid state, long haul system designed for new routes and to supplement TD-2 on existing routes. TD-3 operates in the same frequency range as TD-2, however, it can accommodate 24 channels each consisting of two L-Carrier terminals.

Another system operating in the 4,000 megacycle frequency range has been used for short haul radio relay, although primarily intended for single link pickup service. This was coded the "TE" system which signifies a super high frequency, one-way, television link. The TE equipment was designed for television transmission only and was much simpler and much less costly than TD-2 equipment. The equipment is no longer being manufactured but many units are still in service.

A major disadvantage of TE equipment for radio relay was that the signal was converted from radio frequency to video frequency and back to radio frequency at each repeater point. In other words, it was a series of circuits connected in tandem rather than a continuous circuit and resulted

CHAPTER 18 TD - RADIO SYSTEMS

in considerable signal distortion. Similar types of equipment have been manufactured by RCA and by Motorola and are used by many of the operating companies.

A short haul system designed solely for television transmission which avoids the difficulty of translating the signal to and from video frequency at each repeater point is manufactured by the Philco Corporation and has been used by Long Lines and some of the operating companies. This system is coded the "TLR-2A" in its fixed station form and the "TLR-2B" in portable form and operates in the 5925-6425 megacycle band.

None of these systems have the reliability or freedom from distortion that the TD-2 system enjoys but do provide an economical means of obtaining relatively satisfactory transmission over moderate distances. As a result these systems are used for "side-leg" feeds to isolated stations from main TD-2 routes and for shorter circuits such as studio-to-transmitter links or for service between remote pickup points and the customer's studio or transmitter.

One other type of microwave system has been used by the Long Lines Department and is also manufactured by Philco. It is coded the CLR-6 system and was designed for light route telephone service. It provides a single channel having a bandwidth of approximately 300 kc and operates in the 6,000 megacycle frequency range. By using Philco's multiplexing equipment, which is coded "CMT-4", 24 telephone channels of standard bandwidth can be provided. The CMT-4 equipment does its multiplexing with a system of pulse modulation. In some Long Lines applications the multiplexing has been accomplished on a frequency division basis using type ON carrier terminal equipment.

All these systems have certain things in common. First, a means is provided for translating the audio or video signal frequencies to the radio frequency range selected for transmission. The radio frequencies are either generated in, or amplified by, a transmitter which applies them to an antenna having directed radiation characteristics. One or more repeaters are then employed depending upon the total length of the transmission path.

A repeater consists of an incoming directive antenna; a receiver which converts the radio signal to an intermediate frequency or to video frequency; a transmitter to convert back to radio frequency; and an outgoing directive antenna. At the receiving terminal the receiving antenna and radio receiver are followed by suitable terminal equipment to make the necessary translation between the radio system and the ultimate wire plant destination of the circuit.

Since all of the systems discussed have power outputs in the range of 0.3 to 1.0 watt, and antenna systems of comparable gain, the repeater spacings are generally the same - averaging 25 to 30 miles with an occasional spacing of as much as 50 miles where suitable heights of antenna can be obtained to compensate for the earth's curvature.

18.3

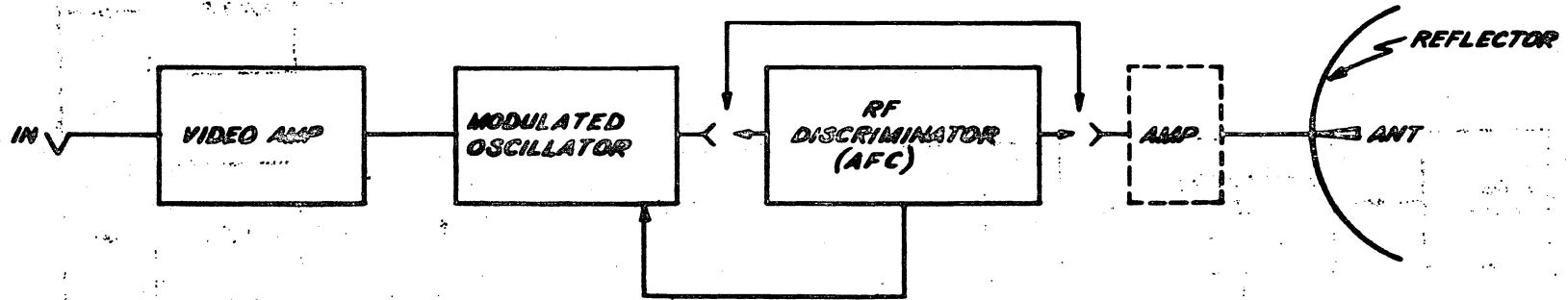

Fig. 18-1 Simple Microwave Transmitting Terminal

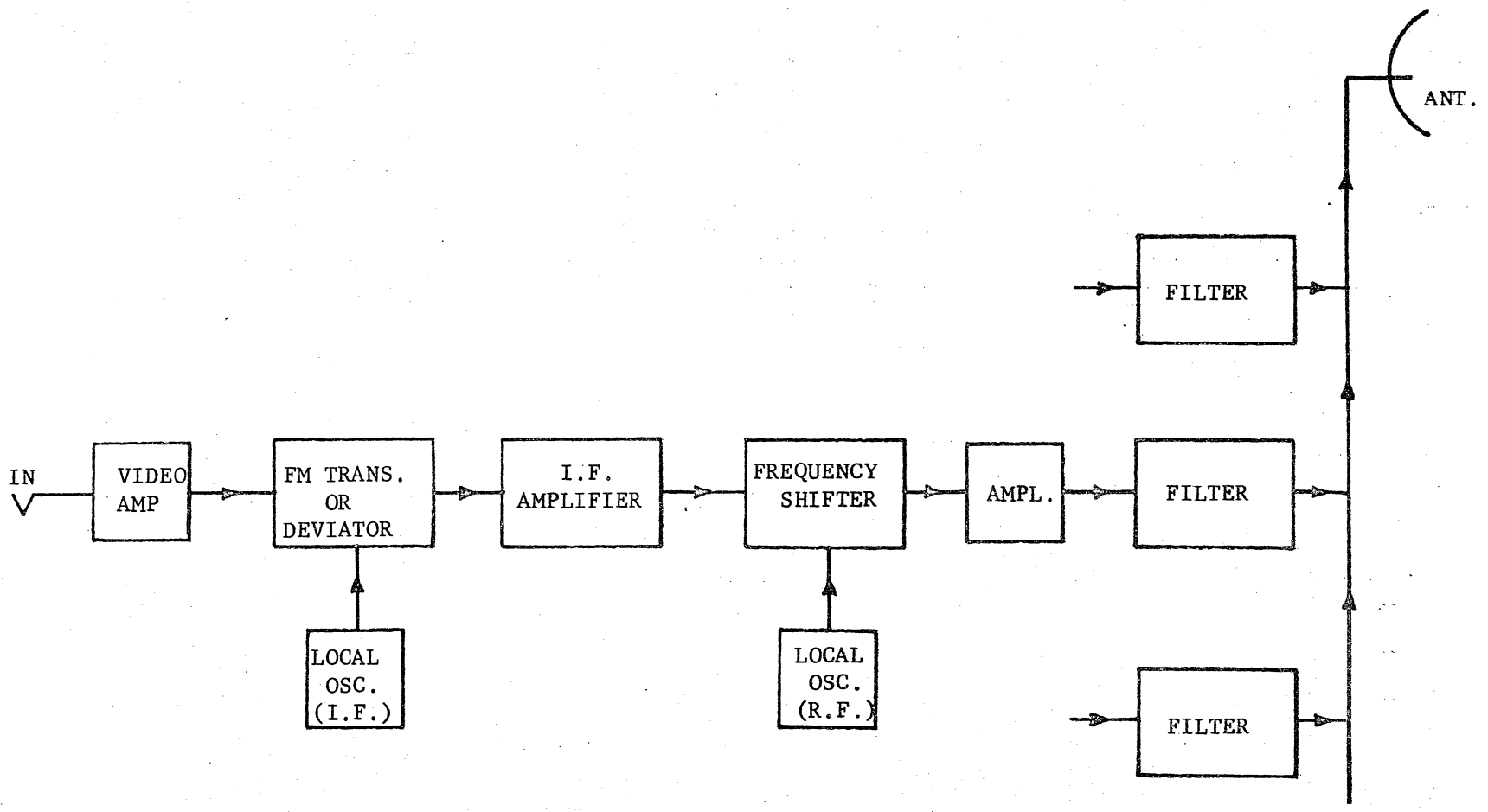

Figure 18-2 Multi-link Microwave Transmitting Terminal

CHAPTER 18 TD - RADIO SYSTEMS

18.2 MAJOR ELEMENTS OF A MICROWAVE SYSTEM

Microwave Transmitting Terminal

Present microwave transmitters operate with frequency modulation. One of the simplest forms of such a transmitter is shown in block diagram form in Figure 18-1. This is illustrative of the single link type systems such as the RCA, Motorola, TE or Philco CLR 6. In this type of system a special vacuum tube is used to generate microwave frequencies. This tube is known as a reflex klystron. In general, the oscillator is directly connected to the antenna or radiating system. This makes an economical arrangement but has certain deficiencies since variations in loading will affect the frequency response of an oscillator and, therefore, introduce non-linearities in its modulation characteristic.

Since an antenna and its coupling system does not make a perfect impedance match between the oscillator and free space at all frequencies, the modulated oscillator has a limited application. Where systems of this type have been used for multi-link application a two-stage microwave amplifier has sometimes been used to isolate the oscillator from the antenna. However, such an amplifier materially reduces the economy inherent in the use of this type of system.

Occasionally a device known as an RF discriminator is connected to the output of the oscillator and used to stabilize the outgoing frequency. The discriminator continually samples the oscillator output and if the frequency drifts from its normally assigned mean the discriminator furnishes corrective information to the oscillator.

In order to obtain sufficient voltage to vary the frequency of the oscillator the input signal is amplified through a wide band amplifier usually called a video amplifier. This nomenclature stems from the fact that systems of this type with the exception of the CLR 6 have been used for video or television transmission.

A more elaborate form of microwave transmitting terminal is diagramed in Figure 18-2 and this is representative of the techniques used with the TD-2 and the Philco TLR-2A or -B microwave systems. In this arrangement the input signal is amplified and applied to a device which may be known as an FM transmitter or a deviator. A low level frequency modulated signal is thus produced in the 70 to 150 megacycle range. This intermediate frequency is then amplified through an IF amplifier and applied to a frequency shifter. The frequency shifter is essentially a mixing or beating device which translates the intermediate frequency to the final radio output frequency. The output of the frequency shifter may then be passed through several stages of microwave amplifier and from there applied to the radiating system. By using a broadband antenna system and inserting bandpass filters between

CHAPTER 18 TD - RADIO SYSTEMS

the output of the radio frequency transmitter and the antenna several transmitters may be connected simultaneously to the same radiating system. This type of radio system is amenable to control of frequency stability to a much greater degree than the previous system shown in Figure 2 and also can be built to introduce much less distortion in the transmitted signal.

Microwave Receiving Terminals

All of the systems discussed above follow the same general procedures at the receiving end; however, the individual circuit arrangements differ with the specific system. The general receiver configuration is outlined in Figure 18-3.

The signal from the receiving antenna system is passed through a microwave filter to a mixer. The input filter serves two functions: first, to separate the individual channels of a multi-channel system and secondly, to prevent the output from an adjacent transmitter at the same location from feeding into or overloading the receiver. The mixer or first demodulator uses a diode of a silicon crystal variety and is furnished with signal from a local oscillator to produce the intermediate frequency at which most of the amplification is done.

Closely associated with the mixer is a pre-amplifier to raise the IF level for feeding to the main IF amplifier which may be located at some distance from the mixer assembly. The main IF amplifier provides the necessary gain to make the very low output from the mixer useful. IF amplifiers may have gains as high as 90 or 100 db. The IF amplifier output is then fed to a frequency modulation receiver which may consist of a limiter to maintain constant input into a discriminator, which is a frequency modulation detector. The discriminator in turn feeds a video amplifier provided to raise the output to standard transmission levels.

The output of the IF amplifier is generally sampled and fed to an automatic gain control circuit which, as its name signifies, automatically controls the gain of the IF amplifier to provide a constant IF output. This circuit compensates for amplitude variations of a random nature in the radio transmission path.

The output of the discriminator may also be applied to an automatic frequency control circuit which will vary the frequency of the local, or beating, oscillator to always produce the same mean IF frequency. This permits the receiver to follow a transmitter which may drift in its average frequency output.

Microwave Repeaters

A repeater provided for the use of single link units consists essentially of a microwave receiving and a microwave transmitting terminal operated back-to-back. In other words the output of Figure 18-3 would be connected directly to the input of Figure 18-1. It is quite apparent that any distortions

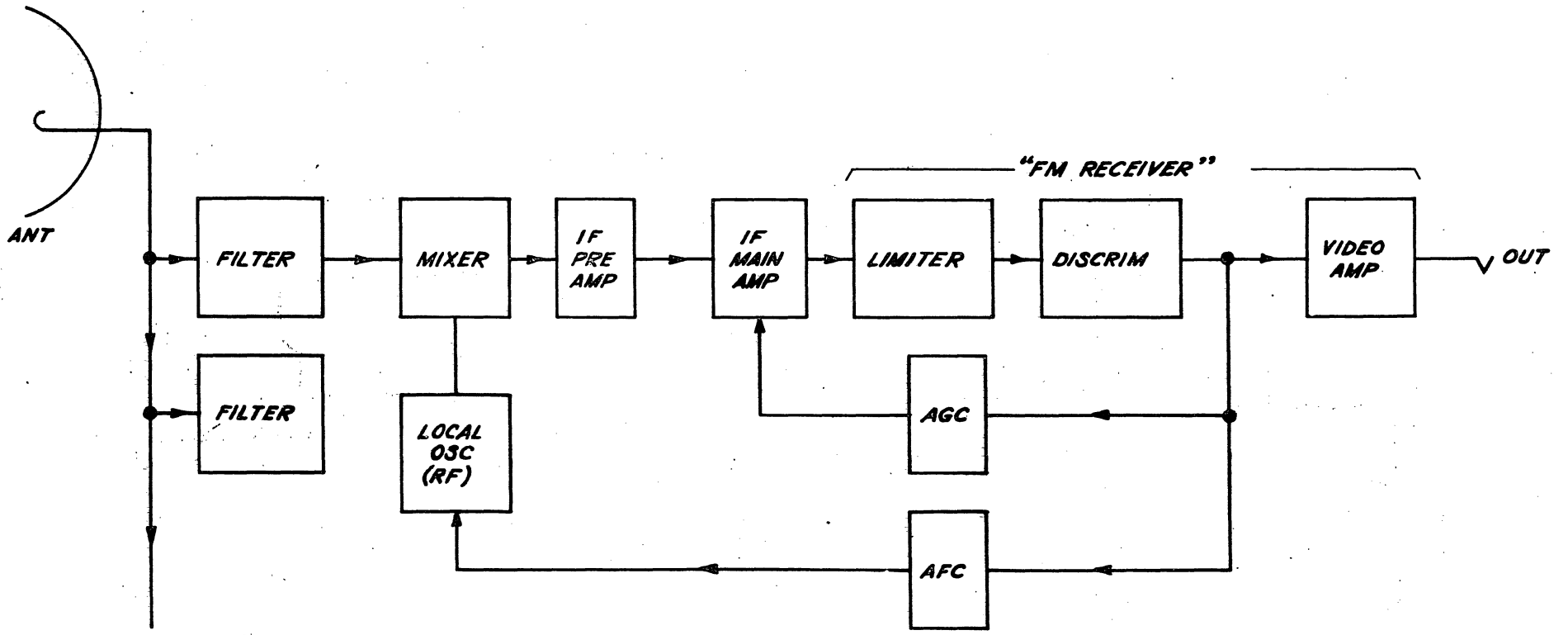

18 7

Fig. 18-3 Microwave Receiving Terminal

18.8

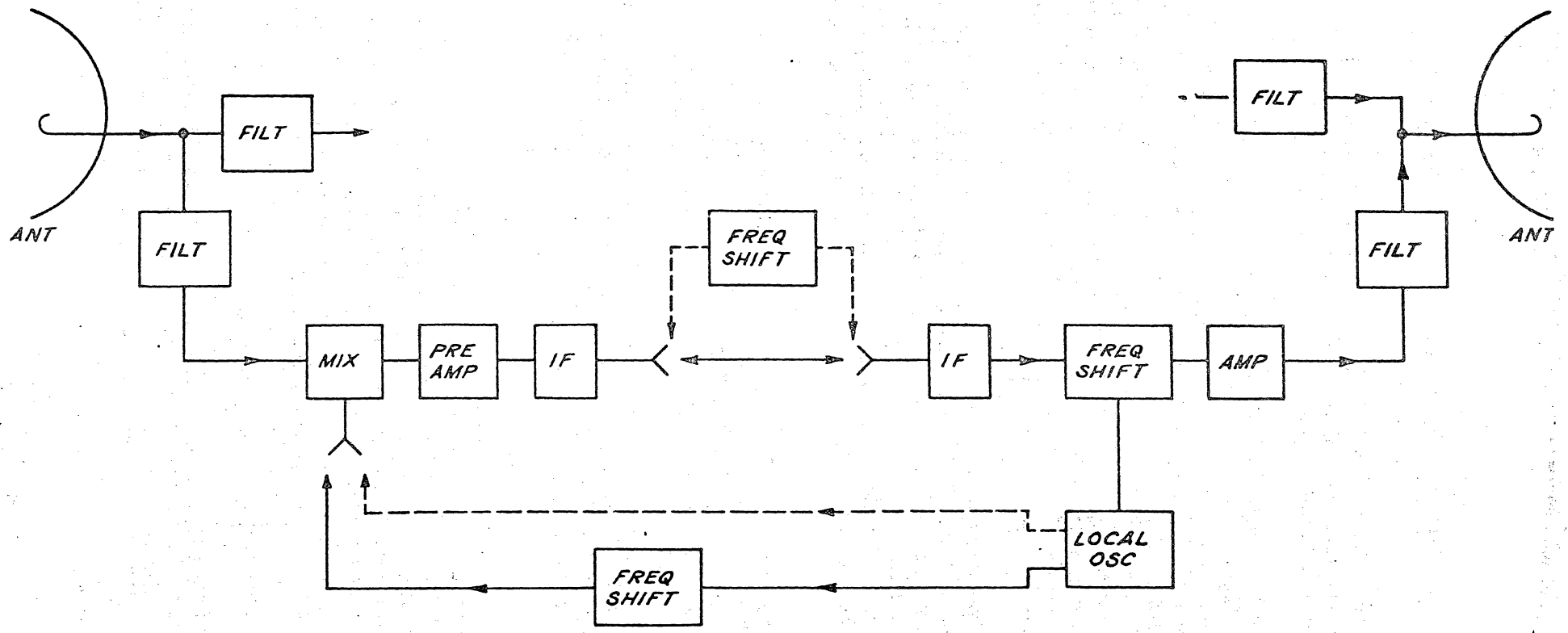

Fig. 18-4 Microwave Repeater

CHAPTER 18 TD - RADIO SYSTEMS

introduced in the transition from radio frequency to signal frequency and then back to radio frequency will be multiplied at each repeater point and such an arrangement is undesirable for long microwave circuits.

The more common arrangement for long haul circuits will follow the general form indicated in Figure 18-4. In this case the output of the intermediate frequency amplifier associated with the receiver is applied to the intermediate frequency input of the transmitter and again translated to radio frequency for direct radiation on the air. In this way any translation to signal frequency is avoided and thus numerous distortions are eliminated. The method of accomplishing this translation is different with different systems and results from the fact that the repeater output frequency is made to differ from the repeater input frequency by 40 megacycles in order to avoid a repeater sing.

If the input and output frequencies were identical some of the transmitted signal would, of necessity, reach the receiving antenna since the antenna systems cannot be made to have zero radiation from the rear. Inasmuch as the radio frequency filters must have a bandpass of 20 megacycles to provide the 20 megacycle channels previously mentioned the minimum safe frequency difference between transmitting and receiving frequencies is 40 megacycles.

In one microwave system the same microwave oscillator is used to furnish the beat signal at the receiver mixer and also the beat frequency for the output frequency shifter. In this case a frequency shift is made in the IF interconnection to provide the 40 megacycle input-to-output difference.

In another microwave system the IF is maintained at the same frequency on both the receiving and transmitting sides but the local oscillator used for the output frequency shifter is in turn shifted 40 megacycles to provide injection frequency for the receiver mixer.

Frequencies

It is desirable to maintain operation over a route with the use of as few frequencies as possible and still provide the minimum of interference between stations. Figure 18-5 indicates the layout of the initial TDX microwave system between New York and Boston. Two one-way channels were provided in each direction with a total usage of four frequencies. These are indicated in the table on Figure 18-5. It will be noted that to avoid crosstalk between channels a separation of 200 megacycles was provided between channels transmitting in the same direction. A 40 megacycle translation occurs at each repeater point as previously discussed.

It will be noted that transmitting from New York toward Boston and transmitting from Birch Hill toward Boston the same frequency is used. This means that it would be possible for the Spindle Hill receive to copy signals from either

CHAPTER 18 TD - RADIO SYSTEMS

New York or Birch Hill (under certain atmospheric conditions) if the stations were all arranged in a straight line. To avoid such a possibility a microwave system is laid out in a zigzag fashion, with sufficient offset to avoid the possibility of pickup from any but the proper transmitting station. The amount of offset introduced in a route of this type is determined by the directional characteristics of the antenna system and the terrain over which the route is operating. By using as few frequencies as possible for the main route maintenance is materially simplified since the duplication of equipment components is high. In addition, frequency spectrum is available for future side-leg feeds from each of the main repeater points.

With improvements in the design and manufacture of microwave channel filters it has been possible to operate with much closer frequency spacing and the TD-2 now operates with an 80 megacycle channel separation. A typical six channel repeater might operate with input frequencies of 3730, 3810, 3890, 3970, 4050 and 4130 megacycles while the corresponding output frequencies would be 3770, 3850, 3930, 4010, 4090 and 4170 megacycles.

It appears that further improvement in spectrum usage will not be derived from improvements in filters alone but more likely in controlling the type of radiation. It is expected that, when band congestion becomes sufficient to warrant the necessary expenditures, five additional channels could probably be interspersed between the six channels just mentioned by using the opposite polarization of the radiated wave. The additional discrimination between horizontal and vertical polarization of the transmitting and receiving systems would materially relieve the requirements on skirt selectivity of the bandpass filters without reducing the desired 20 mc bandpass.

In the following paragraphs the Bell System Microwave Systems in present use are discussed.

18.3 "TD-2" SYSTEM

The TD-2 Radio System operates in the common carrier band between 3700 and 4200 mc. This 500 mc band is divided into 12 microwave channels, the midband frequency of each being spaced 40 mc apart, with a channel bandwidth of 20 mc. Channels in any one direction are spaced 80 mc apart with a 40 mc shift between receiving and transmitting frequencies to prevent a transmitter from interfering with a receiver. This allocation of frequencies allows six channels in each direction of transmission to be spaced within the common carrier band. A typical channel frequency allocation arrangement at two adjacent radio repeater stations is shown in Fig. 18-6. At any one station the transmitting frequencies in both directions are the same. This also applied to the receiving frequencies. All transmitting channels are served by one antenna, and all receiving channels by a second antenna of identical design. The system therefore requires only two antennas at terminals and four at repeater relay points. In practice, two 20-mc channels are used for each of six two-way channels numbered as indicated below:

	<u>NEW YORK</u>	<u>JACKIE JONES</u>	<u>BIRCH HILL</u>	<u>SPINDLE HILL</u>	<u>JOHN TOM</u>	<u>BALD HILL</u>	<u>ASNE-BUMSKIT</u>	<u>BEAR HILL</u>	<u>BOSTON</u>
CHAN. 1	3930	3970	3930	3970	3930	3970	3930	3970	
CHAN. 2	4130	4170	4130	4170	4130	4170	4130	4170	
CHAN. 1	3970	3930	3970	3930	3970	3930	3970	3930	
CHAN. 2	4170	4130	4170	4130	4170	4130	4170	4130	

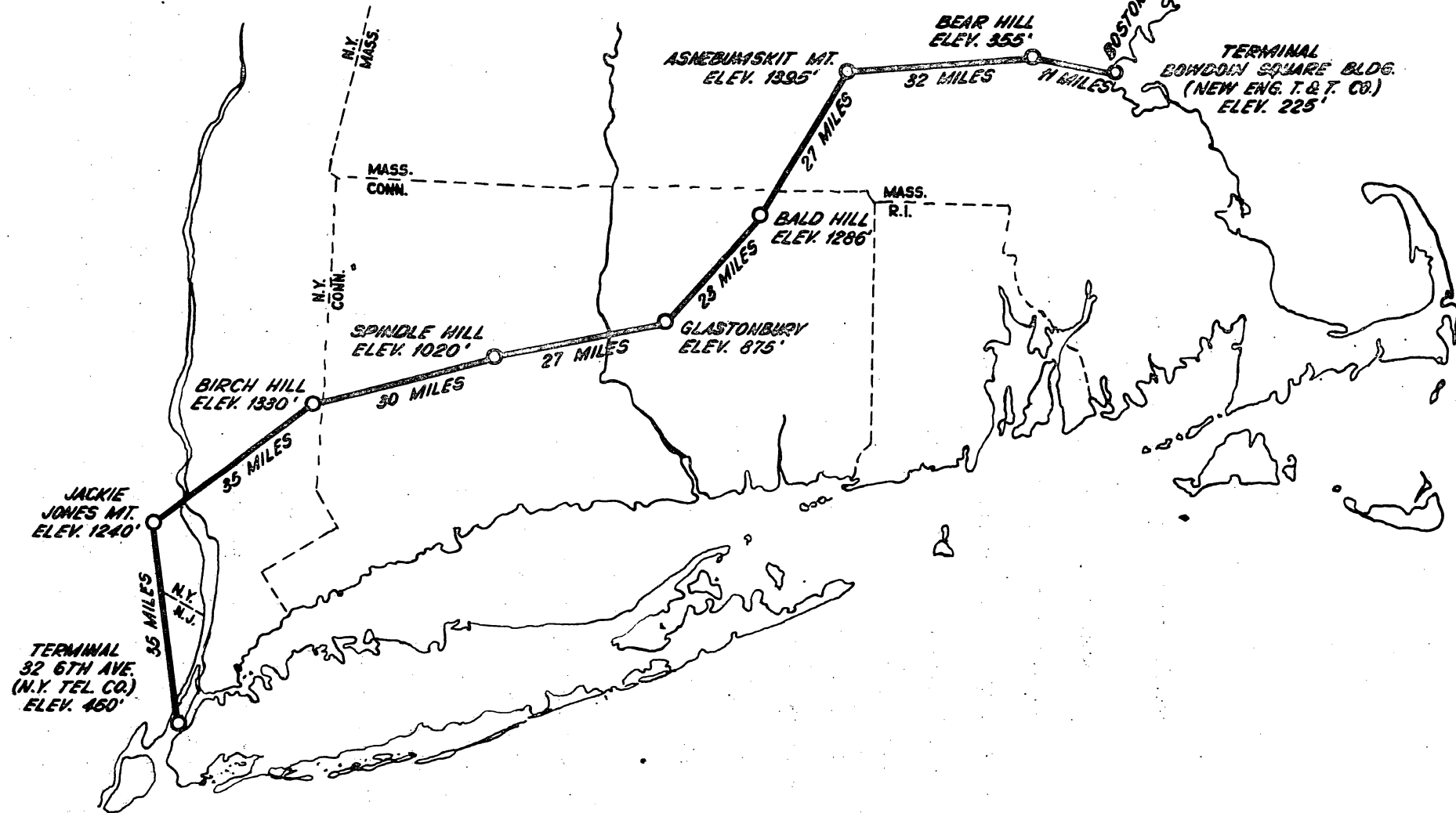

INITIAL NEW YORK - BOSTON RADIO RELAY SYSTEM

Fig. 18-5

CHAPTER 18 TD - RADIO SYSTEMS

<u>Channel No.</u>	<u>Frequencies</u>
1	3720-3740 mc and 3760-3780 mc
2	3800-3820 mc and 3840-3860 mc
3	3880-3900 mc and 3920-3940 mc
4	3960-3980 mc and 4000-4020 mc
5	4040-4060 mc and 4080-4100 mc
6	4120-4140 mc and 4160-4180 mc

Although these frequencies are the general standard for through circuits on a backbone route, it is possible to use "slot" frequencies where spur or other routes intersect at an angle of approximately 90 degrees. The slot frequencies are spaced 20 mc, or halfway between the standard frequencies. Where such spur channels are required, interference may result from the use of the same frequencies in more than one direction at a radio station.

Figure 18-7 is a simplified block schematic of the TD-2 transmitting terminal. As there indicated, the input signal, which may cover all or part of a band between 30 cycles and about 4 megacycles, is first amplified by a video amplifier, which increases the amplitude of the signal waves to a maximum of 8 volts peak-to-peak. When multiplex telephone signals are being transmitted, the output of the video amplifier is applied to the FM modulator. For television, a clamping circuit is included between the amplifier and modulator. This adds a d-c component to the signal to clamp it to the amplitude value of the trips of the horizontal synchronizing pulse as a base line.

Frequency modulation is obtained in a comparatively simple manner by applying the signal directly to the repeller electrode of a reflex-klystron oscillator,

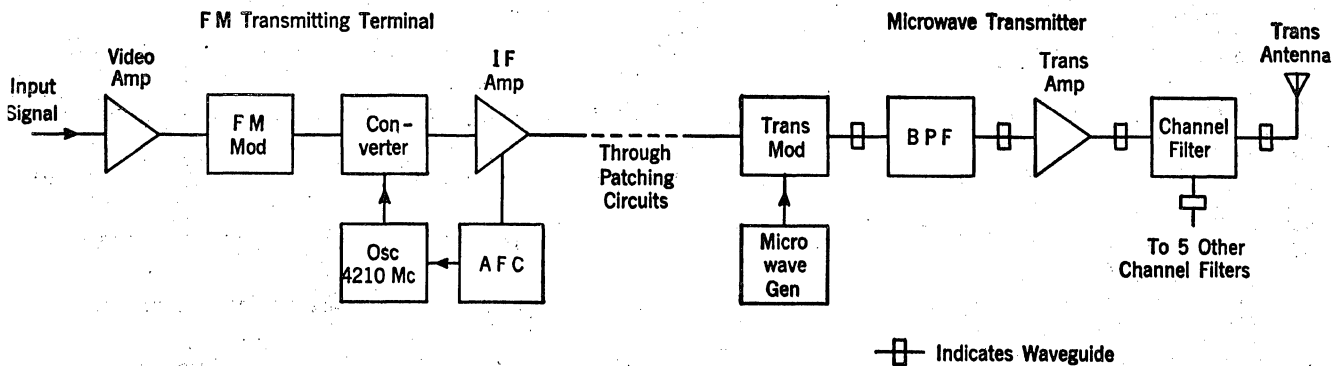

Fig. 18-7 TD-2 Transmitting Terminal

which is tuned to a nominal frequency of 4280 mc. A signal level of 8 volts peak-to-peak at the repeller produces ± 4 mc frequency modulation. The frequency-modulated carrier is then applied to a converter, whose active component

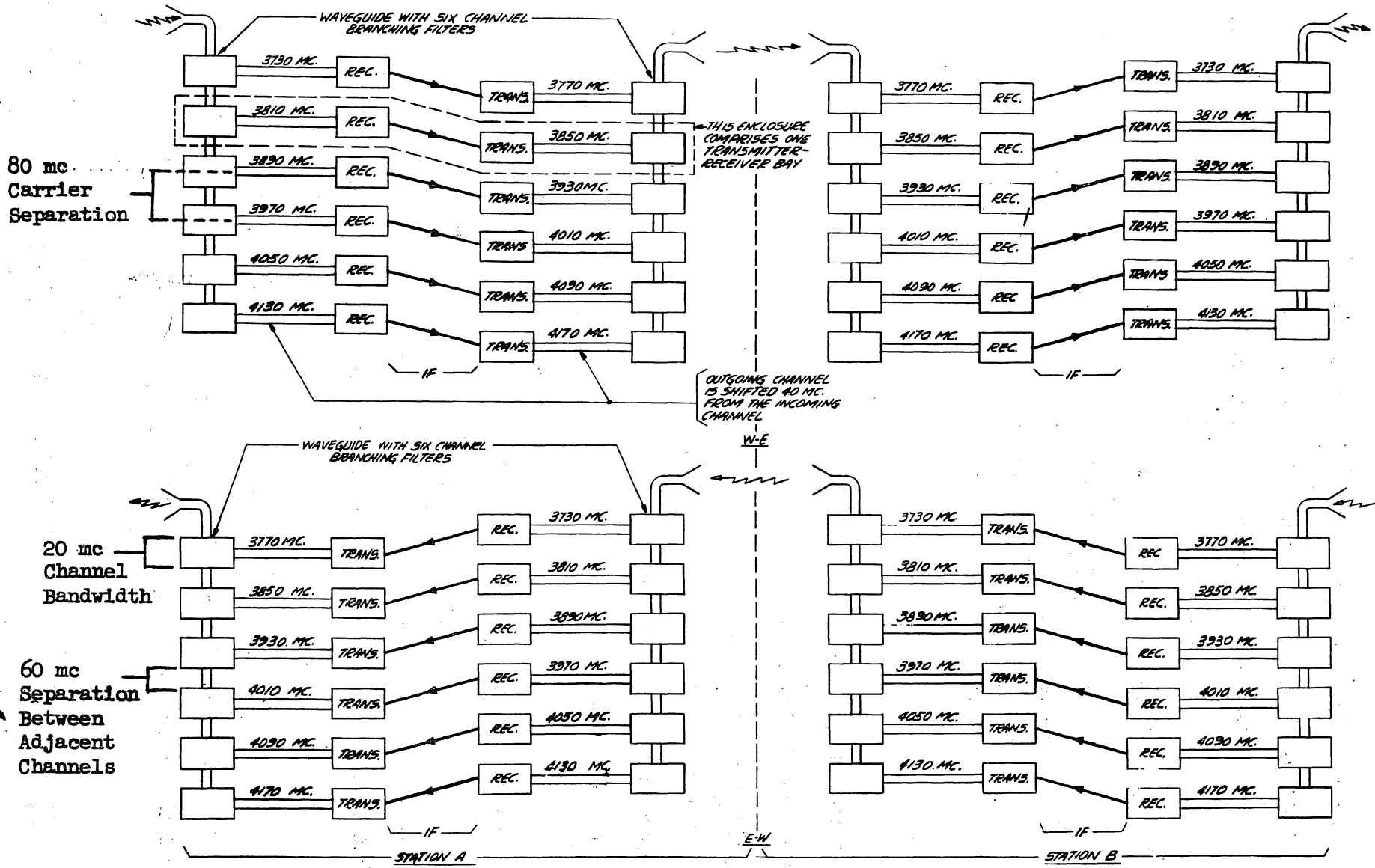

Fig. 18-6 - Frequency Allocation Chart

18.13

CHAPTER 18 TD - RADIO SYSTEMS

is a point-contact varistor, where it is mixed with the output of a 4210-mc beating oscillator. The resultant converter output is an intermediate frequency normally centered about 70 mc and ranging between 74 and 66 mc. This of course represents the difference between the two frequencies applied to the converter. The four-stage IF amplifier raises the level of the modulated IF signal to +13 dbm. A small portion of the amplifier output is picked off and applied to a slow acting automatic frequency control circuit, which, in the case of telephone transmission, measures the average frequency at the amplifier output and adjusts the beating oscillator so that this average frequency remains constant at 70 mc. For video transmission, the AFC circuit measures the amplifier output frequency only during the horizontal synchronizing pulses and adjusts the beating oscillator frequency to hold this frequency constant at 74 mc.

All the components discussed above comprise what is generally known as the FM transmitting terminal. The modulated signal output of this terminal, after passing through appropriate switching or patching circuits, is applied to the microwave transmitter itself. The transmitter modulator Figure 18-8 translates the IF signal to the desired microwave frequency. The modulator employs a 416 type tube, and is supplied with the proper beat-frequency from a microwave generator whose output frequency is 70 mc removed from the desired microwave channel frequency. The basic unit of the microwave generator is a very stable crystal-controlled oscillator operating in the frequency range from 17.5 to 19.0 mc, depending on the frequency of the crystal employed. The basic oscillator is followed by a series of frequency-multiplying stages providing a total multiplication factor of 216. The modulated output is led through a band-pass waveguide filter, which selects the upper side-band. The microwave transmitter amplifier is capable of producing an output of +27 dbm (slightly more than 1/2 watt). This output is fed through a channel filter where it is joined by the outputs of five other transmitting channels and applied collectively to the transmitting antenna.

At the receiving terminal of a microwave channel, the incoming channels are separated by channel filters, as indicated in Figure 18-9. The incoming energy for each channel then passes through an image rejection filter. This is a band-pass filter designed to have particularly high suppression characteristics in the neighborhood of the image frequency 140 mc away from the signal frequency. The receiver converter is a demodulator employing point-contact varistors, in which the SHF signal is mixed with the output of a microwave generator to again produce the 70 mc IF. This is passed through an IF pre-amplifier having a gain of about 12 db to an 8-stage main IF amplifier having a maximum overall gain of about 60 db. Associated with this amplifier is an automatic volume control circuit which compensates for differing input levels due to fading and holds the output power constant at approximately +9 dbm. The FM receiving terminal includes limiting and discriminating circuits which convert the frequency-modulated 70 mc signal back to its original amplitude-varying form in the frequency range between 30 cycles and 4 megacycles. This signal is applied to a video amplifier whose pushpull output voltage is about 2.0 peak-to-peak.

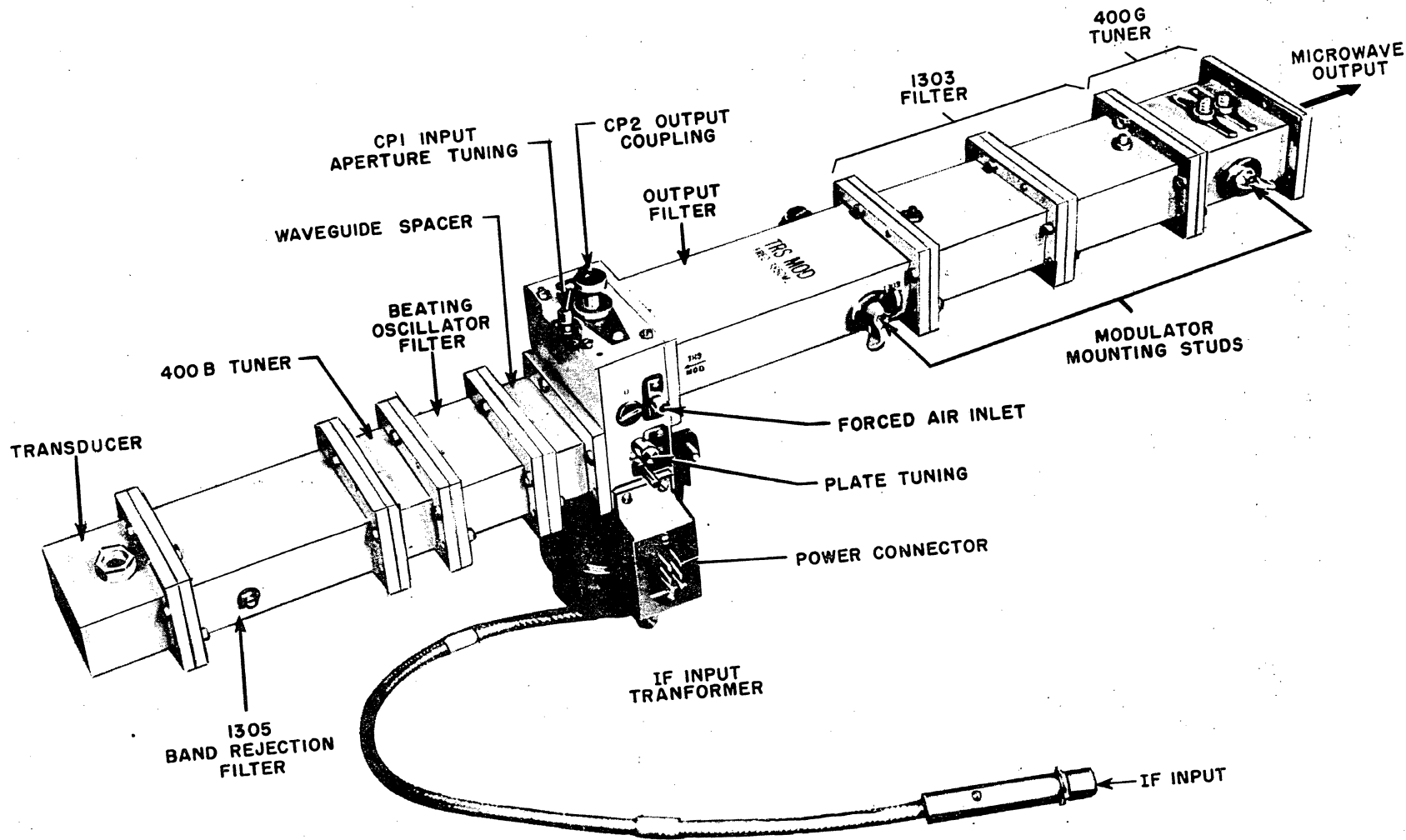

Fig. 18-8 Microwave Transmitter Modulator

CHAPTER 18 TD - RADIO SYSTEMS

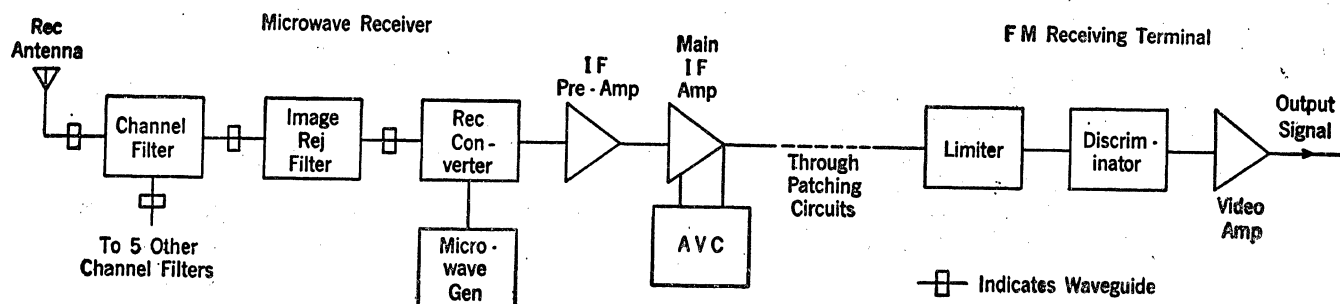

Fig. 18-9 TD-2 Receiving Terminal

Repeater stations, which are located at intervals of about 25 miles along the radio relay routes, are of two types - main and auxiliary. Main stations include switching and branching circuits, while auxiliary stations are arranged only to receive, amplify and re-transmit the radio signal. The layout of the main repeater station may be represented by connecting together, through patching circuits, a microwave receiver as shown schematically at the left of Figure 16-9 and a microwave transmitter as shown at the right of Figure 18-7. The 40-mc frequency shift that is made at all repeaters is obtained by using conversion frequencies that differ by 40 mc. In the auxiliary repeater arrangement which is shown in block schematic in Figure 18-10, a single microwave generator is used to supply both the receiver converter and the transmitter modulator. The 40-mc shift is secured by the use of a "shifter converter" which mixes the microwave generator output with the output of a separate 40-mc oscillator to provide a supply for the receiver converter that differs by 40 mc from the microwave generator frequency.

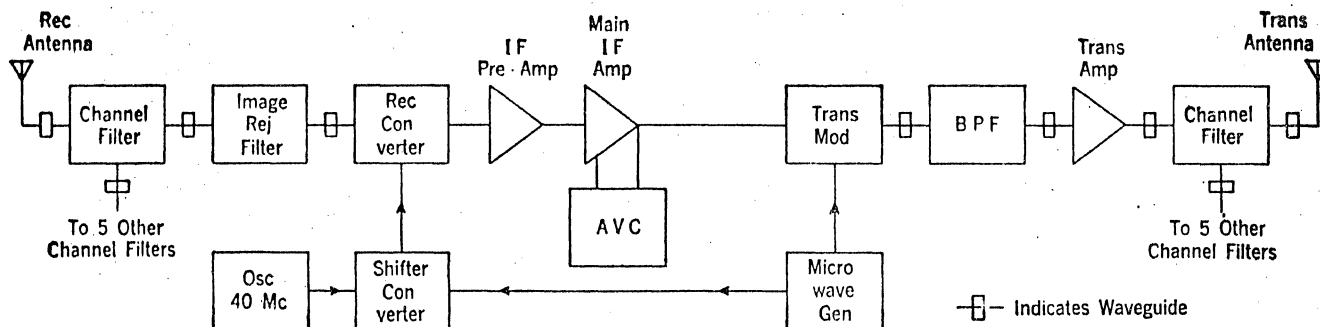

Fig. 18-10 TD-2 Auxiliary Repeater

CHAPTER 18 TD - RADIO SYSTEMS

It will have been noted that the general operating principles of the microwave system have much in common with the more usual radio and carrier systems. Because of the extremely high frequencies employed, however, most of the apparatus units differ radically in design from those of relatively low-frequency systems. One of the most interesting examples of such design difference is found in the channel filters of the TD-2 system. The key component of these filters is a device known as a waveguide hybrid, one form of which is illustrated in Figure 18-11 together with its circuit analog. When the impedances of the four waveguide arms are properly matched, energy entering arm C will divide equally between arms A and B and none will reach arm D. Similarly, energy applied at D will divide equally between arms A and B with no output to C. However, when the input is to arm C, the outputs of arms A and B are in phase opposition, while with the input at D, the outputs at A and B are in phase. This may be understood by referring to the circuit analog. It follows that when equal and in-phase voltages are applied across arms A and B there will be no output to arm D and full output to arm C. On the other hand, if the equal inputs of arms A and B are 180° out of phase, there will be no output at C and full output at D.

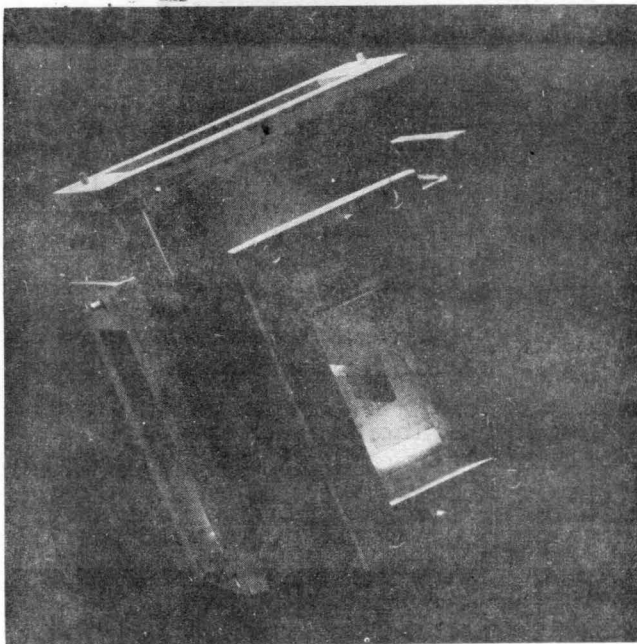

Fig. 18-11 (a) One Form of Waveguide Hybrid

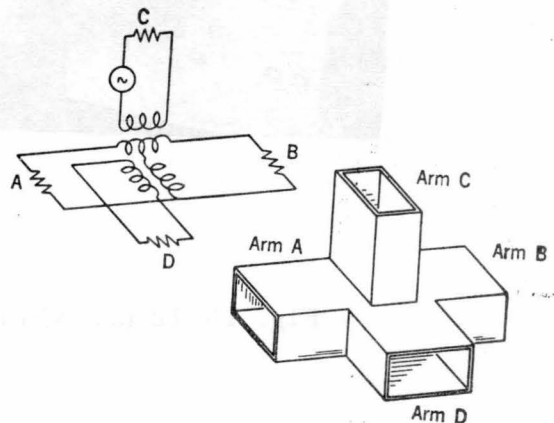

Fig. 18-11 (b) Waveguide Hybrid and Circuit Analog

Microwave Channel Separation Network (Branching Filter)

The arrangement for employing these waveguide hybrids to obtain filter action is illustrated schematically in Figure 18-12. The total microwave energy coming from the antenna enters the upper hybrid at arm C and divides equally between A and B with no transmission at D. Inserted in series with both arms

CHAPTER 18 TD - RADIO SYSTEMS

A and B are identical band-reflection filters tuned to reflect the frequency band of one particular microwave channel but to pass all other frequencies. The frequencies of the reflected channel band travel back to the hybrid and are applied to arms A and B. Because one of the band-reflection filters is located one-quarter wavelength farther away from the hybrid than the other, the energy reflected by one has to travel a half-wavelength farther than that traveled by the other in going from the hybrid to the reflection filter and back. The reflected waves are there 180° out of phase when they reach the hybrid and the total reflected energy is therefore transmitted to arm D and thence to the channel receiver.

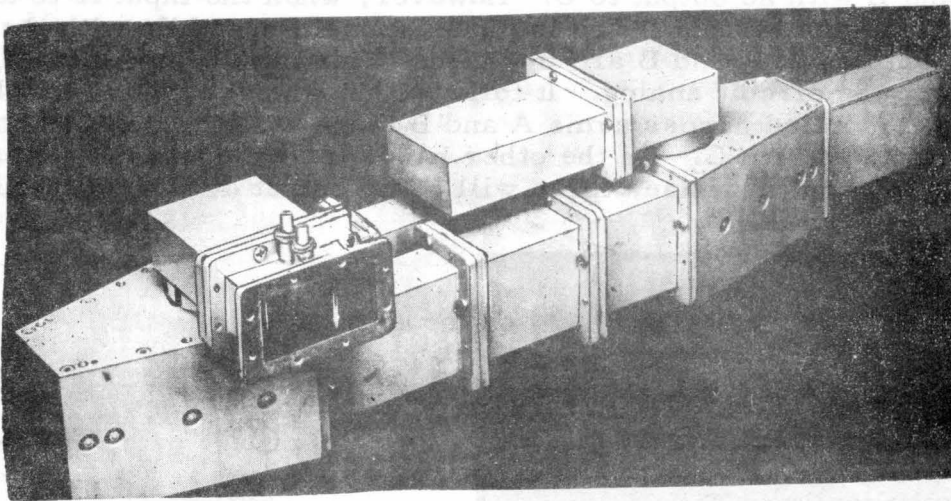

Fig. 18-12 (a) Microwave Channel Branching Filter

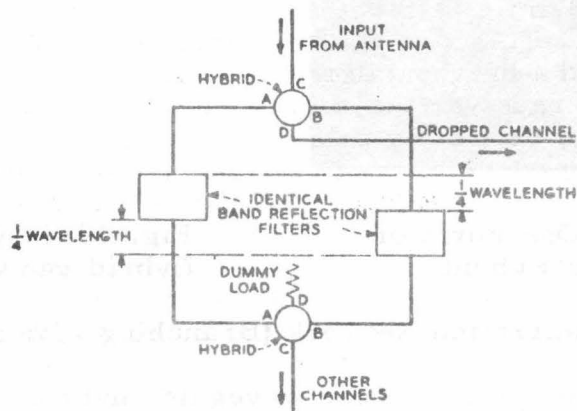

Fig. 18-12 (b) Simplified Schematic Channel Branching Filter

CHAPTER 18 TD - RADIO SYSTEMS

The energy that was not reflected by the filters passes on to arms A and B of the second hybrid in phase and is accordingly transmitted to arm C. This is connected to another arrangement identical to that of Figure 18-12 except that its filters are tuned to reflect a different channel band; and so on until all channels have been dropped off to their respective channel receiving circuits.

18.4 INTERSTITIAL CHANNELS

In the ten years since the first TD-2 system was installed the demand for intercity television and voice circuits has increased tremendously. To meet this expansion the Bell Telephone Laboratories has devised a method of adding interstitial on "in-between" channels to existing TD-2 systems. This addition was possible since the present TD-2 channels are separated by 20 megacycles.

Six additional two-way microwave channels may be derived by utilizing the interstitial bands mentioned above. A frequency plan for such operation is shown in Fig. 18-13, in which the six additional channels are shown as dotted lines. It will be noted that here adjacent receiving channels are only 20 mc apart and, furthermore, the minimum difference in frequency between transmitters and receivers on the same tower is also 20 mc.

Inasmuch as the total discrimination of the repeater to frequencies 20 mc from midband is not great, supplementary means had to be found for improving the discrimination between such closely spaced channels. For far-end interference between similarly directed channels only 20 mc apart, additional discrimination may be obtained by transmitting one set of six channels with vertical polarization and the other set of six channels with horizontal polarization, as shown symbolically in Fig. 18-13. The two sets of oppositely polarized channels are separated at the receiving waveguide by means of a suitable network.

It is essential that during fading the amplitude of the vertical component of any particular horizontally polarized carrier shall not become excessive relative to the amplitude of the vertically polarized carrier located 20 mc away, and vice versa. Cross-polarization during fading periods was studied experimentally on a 23-mile path between Murray Hill, New Jersey, and Holmdel, New Jersey. This was done by transmitting a vertically polarized carrier at 4008 mc and a horizontally polarized carrier at 3980 mc, and observing them with a receiver tuned to each but with both receivers arranged to accept only vertically polarized waves. Fig. 18-14 is a cumulative distribution curve of the instantaneous difference in level between the two received components obtained in the month of September 1954. It should be pointed out that, by nature of the recording means, there is an inherent uncertainty of ± 5 db in the observed values of discrimination. Fig. 18-14 shows that during this period the cross-polarization discrimination was poorer than 20 ± 5 db for only about 0.002 per cent of the time.

CHAPTER 18 TD - RADIO SYSTEMS

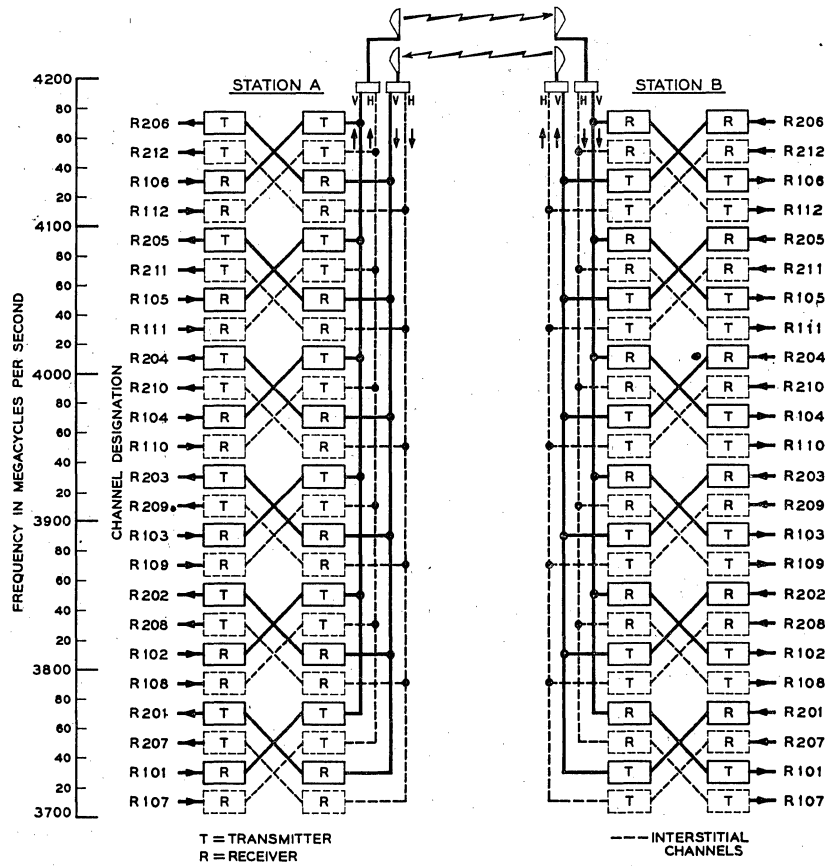

Fig. 18-13 Frequency Plan For 12 Channels

While the use of cross-polarization materially improves the interference from far-end couplings, it does not appreciably increase the side-to-side coupling loss between antennas; consequently, near-end cross-talk becomes an important consideration in interstitial channel operation.

18.5 TD-3 SYSTEM

The following comparison of system characteristics will show how long haul microwave operation will be improved with the introduction of TD-3.

CHAPTER 18 TD - RADIO SYSTEMS

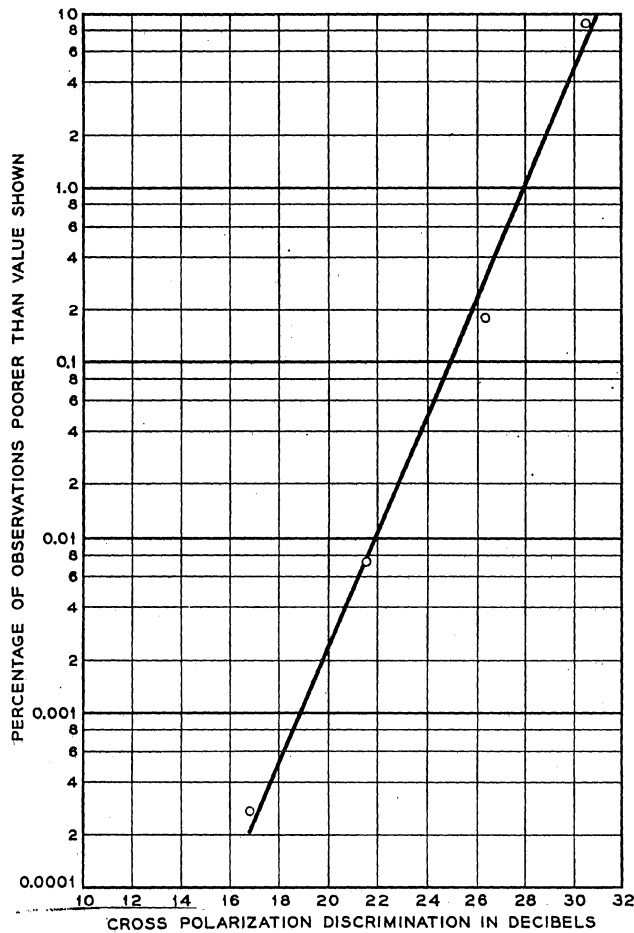

Fig. 18-14 Cross-polarization Discrimination

	<u>TD-2</u>	<u>TD-3</u>
Carrier Freq.	4GC	4GC
Min. Repeater Gain	81 db	101 db
MSG Ckts/Channel	600	1,200
Noise Figure	12 db	7 db
Noise Performance	40 dbao	35 dbao
Transmitter Output	27 db (1 watt)	37 db (5 watts)
Baseband Width	6 mc	12 mc
Reliability	0.16%	0.01%

TD-3 Components

In considering characteristics of the various components of a TD-3 repeater bay, the objectives discussed here are in general terms only as the design of some components may not be final at this time.

CHAPTER 18 TD - RADIO SYSTEMS

A simplified block diagram of the TD-3 Repeater is presented in Figure 18-15. The most pronounced difference between TD-2 and TD-3 that may be noted here is the incorporation of a Parametric Amplifier in the front end and a Traveling Wave Tube (TWT) final output amplifier. Except for the TWT, the electronic circuitry is of solid state design.

The TD-3 system will operate on the same frequency plan as TD-2, 3,700 mc to 4,200 mc and will provide for 12 two-way channels.

Antenna

Since TD-3 is to be compatible with TD-2, the antenna and much of the waveguide will be common.

Waveguide Networks

The channel dropping networks and channel band pass network will be similar to those used on TD-2 but with greater band width and more stringent requirements on the loss and phase characteristics. The channel dropping networks consist of resonant cavities coupled to the main waveguide. In order to obtain adequate control of the coupling, both the diameter of the coupling orifice and the thickness of the waveguide wall must be held to tolerances of ± 0.001 inch. Also, to obtain the desired temperature stability, invar copper laminate waveguide will be used in place of the normal copper in construction of the channel dropping and channel band pass networks. Where TD-2 and TD-3 are to be intermixed the TD-2 bays will have to be equipped with the new channel dropping networks in order that the TD-3 portion meets its objectives.

The channel pass filter is made up of a number of resonant cavities spaced along the waveguide. In order to achieve the more stringent requirements for TD-3 it was found necessary to increase the number of cavities over that used in TD-2. The spacing between cavities has been reduced from three quarter wave length to one quarter wave length to hold the filter to a reasonable length. This closer spacing of the cavities entails the use of three post construction to reduce the coupling between cavities over the one post TD-2 type. Also, the position of the posts must be controlled to ± 0.002 " and the post diameter to ± 0.002 ".

Isolators

There will be considerably more isolation between components in the TD-3 system than was necessary on TD-2. The isolator characteristics are less than 0.2 db forward loss, 37 db reverse loss and about 35 db return loss. There will be eight of these isolators used in the TD-3 repeater bay.

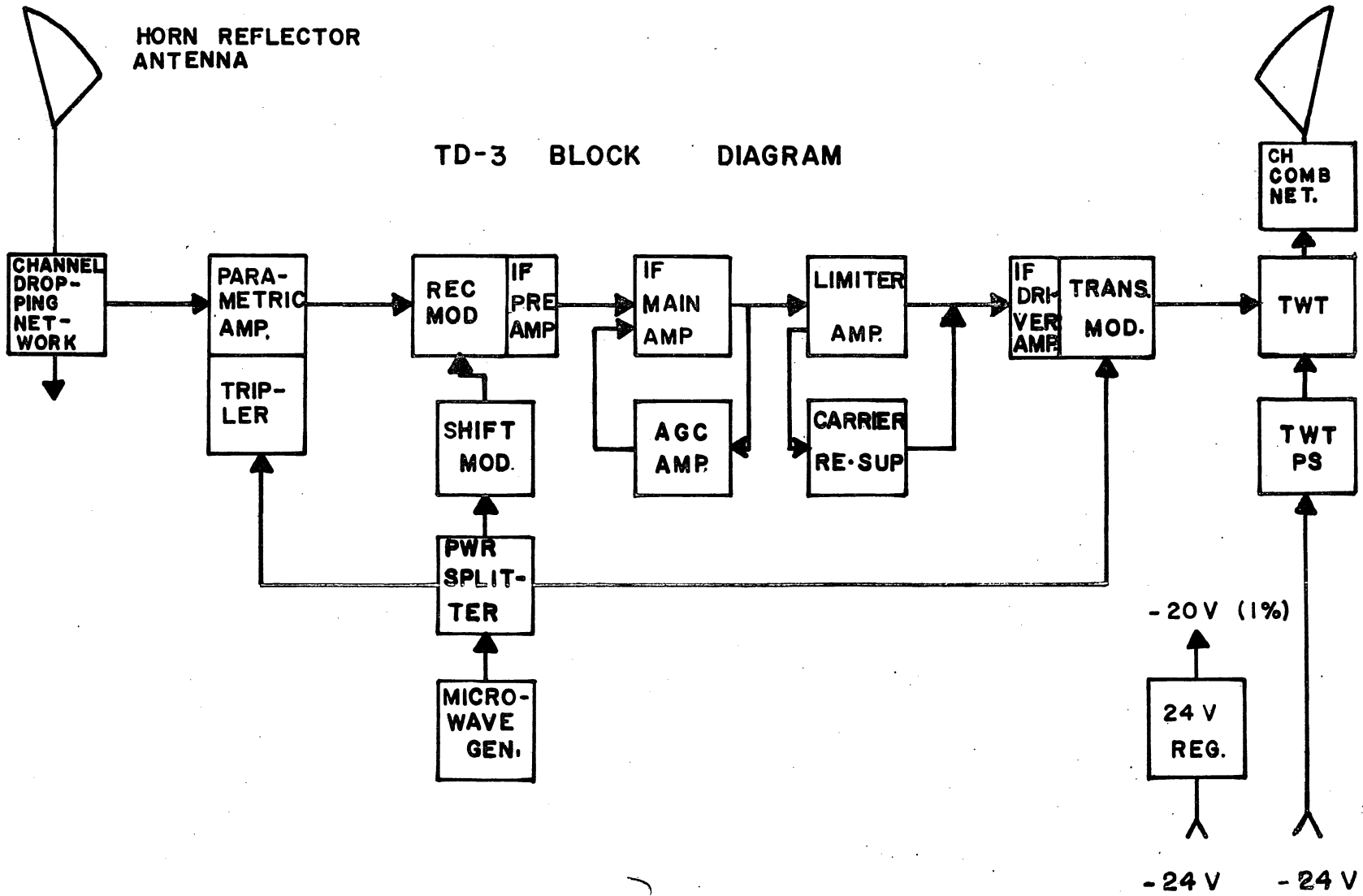

Fig. 18-15

CHAPTER 18 TD - RADIO SYSTEMS

Parametric Amplifier

The paramp, tripler and varactor assembly is a very complex part of TD-3. The assembly also includes a circulator, level amplifier and other associated coax and waveguide apparatus required for filtering, isolation and monitoring.

Energy is coupled from the microwave generator through the power splitter to the tripler (Figure 18-16). Here the frequency of this energy is multiplied to three times the incoming signal frequency and is referred to as the "pump frequency". The pump frequency is fed to the paramp through an isolator, filter and directional coupler where a sample is fed to the automatic Level Control Amplifier which is coupled to the tripler and controls the tripler output by varying the circuit loss. The incoming signal is coupled to the paramp through a four port circulator.

The paramp is essentially two tuned circuits (cavities) coupled with a varactor diode. The pump frequency is fed to one of the tuned circuits and is applied across the varactor diode. The characteristics of the diode are such that its capacitance varies in a nonlinear fashion with voltage. This varying reactance is applied to the two tuned circuits and as the incoming signal is coupled to the second tuned circuit, non linear mixing or multiplication of the two signals occur. It is in this non linear conversion that amplification is attained with the energy being derived from the pump source. The amplified signal is then coupled through the circulator to the Receiver Modulator. The importance of the parametric amplifier is that this gain may be obtained over a wide frequency band with very low noise.

The amplifier will have a frequency response that is flat within ± 0.01 db over a band ± 6 mc from midband frequency. Over a ± 10 mc band width the response must be flat within ± 0.05 db. In addition, there must be no discernable ripple over ± 20 mc from the midband frequency.

The nominal input signal level is - 30 dbm. With a short hop this could increase to - 24 dbm. The amplifier gain is 12 to 15 db and the noise figure will be about 4 db.

Modulators

The receiving modulator has the IF preamplifier, which is a printed wiring board assembly, mounted in a recess in the modulator housing. The nominal loss for the modulator is about 6 db and the noise figure for the combined modulator and IF preamplifier assembly will be about 12 db or lower.

PARAMP TRIPLER BLOCK DIAGRAM

18.25

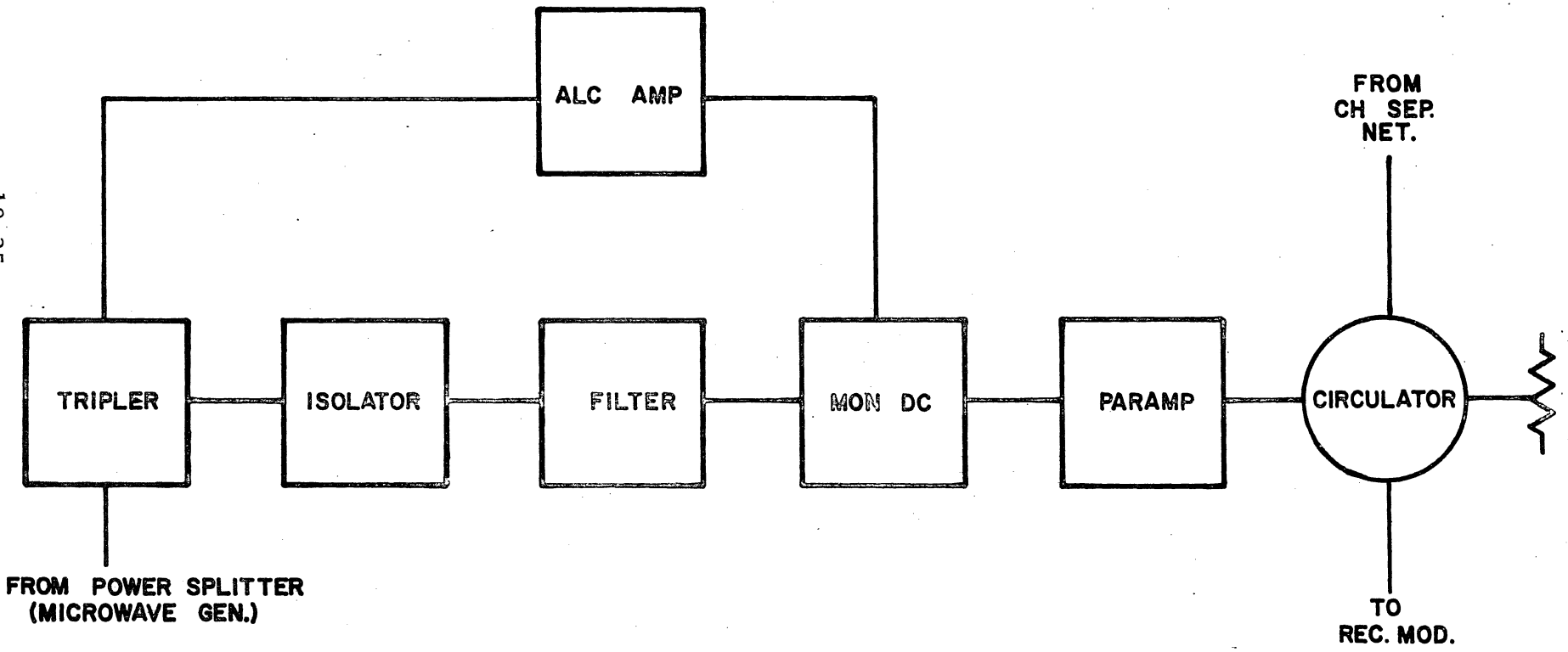

CHAPTER 18 TD - RADIO SYSTEMS

Fig. 18-16

CHAPTER 18 TD - RADIO SYSTEMS

The shift modulator is similar to the receiving modulator with the exception of the printed wiring board which in this case will be the 40 mc oscillator circuitry.

The transmitting modulator again is similar to the other two except for the printed wiring board assembly which is the IF driving amplifier. Carrier suppression through the modulator must be 30 db and the conversion gain will be approximately 10 db.

IF Amplifiers

The total IF amplification is accomplished in four stages, preamplifier, main amplifier, limiter amplifier and IF driver amplifier.

The IF preamplifier is intimately associated with the receiver modulator and as previously stated is mounted in a recess in the modulator block assembly. The preamplifier has four stages of amplification with a noise figure of approximately 4.5 db and a gain of about 19 db. The nominal input signal level is --- 18 dbm to the modulator and approximately - 24 dbm to the preamplifier. However, the amplifier must be able to accommodate a signal level of - 18 dbm to allow for an upfade and an increase in a signal level due to short hops. The amplifier is assembled on a printed wiring board about 3" by 3 1/2". The printed wiring boards for all the IF circuits are made of a teflon glass laminate.

The main IF amplifier consists of 18 transistors and 7 diodes. Figure shows a typical stage of the IF amplifier with an associated vario-losser circuit. There are seven vario-lossers in the amplifier assembly which function in connection with the AGC amplifier to control the over-all gain of the IF amplifier. In order to maintain the gain-frequency characteristics required for TD-3 it is desirable to operate the transistor amplifier stages under fixed bias conditions. The AGC amplifier output is applied across a diode, which is connected between the signal path and ground, between amplifier stages. In this arrangement the AGC output varies the diode (vario-losser) resistance to ground and thereby controls the over-all gain of the IF amplifier.

The maximum gain of the amplifier is 47 db with an AGC range of 35 db. The amplifier is designed to maintain its gain-frequency characteristics through the AGC range. The objective is a response flat to within ± 0.01 db over the band 70 ± 6 mc and 0.03 db over the band ± 10 mc. The amplifier assembly is in two sections mounted in a common panel. The associated AGC amplifier portion is a separate assembly and panel.

The IF limiter follows the main amplifier and will provide 30 db suppression of amplitude variations for modulating frequencies up to 6 mc. The phase shift introduced must be less than 0.20 degrees per db of amplitude variation to limit the amount of AM to FM conversion.

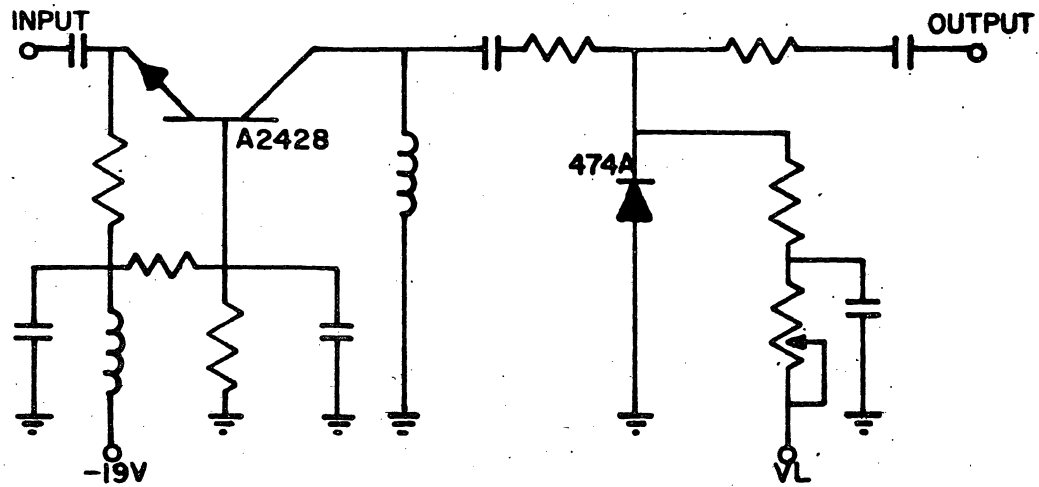

18.27

Fig. 18-17 Typical I. F. Stage

CHAPTER 18 TD - RADIO SYSTEMS

The IF driver amplifier is incorporated with the transmitting modulator and mounted the same as the IF preamplifier. The driver amplifier has a response requirement of ± 0.01 db over a band of ± 6 mc and ± 0.03 db over a band of ± 10 mc.

Traveling Wave Tube Amplifier

Final amplification is accomplished with a new design traveling wave tube. This tube (461A) is a 6.5 watt TWT amplifier operating from 3.7 to 4.2 Gc, periodic permanent magnet focused with waveguide coupling. The magnetic circuit commonly referred to as a PPM package is reusable. The reconditioning to be done at the factory. In order to get the waveguide input and output circuits between the magnets it was necessary to reduce the waveguide "B" dimension to 0.100 inches and 0.328 inches respectively for the TWT input and output. The 21A (input) and 32A (output) transducers were designed to transform from these heights to standard WR229 waveguide. The amplifier is about 3 inches x 4 inches square and about 16 inches long and mounts on top of its power supply. A heat sink is incorporated for cooling the collector of the traveling wave tube, thereby eliminating the need for forced air cooling.

The amplifier assembly has a gain of 32 db with an output level of + 37 dbm and a noise figure of about 30 db. The power supply operates from - 24 volt battery and contains a solid state inverter which operates at about 5,000 cps. The output of the inverter is stepped up by a transformer and rectified by solid state diodes to provide the high voltage necessary for the traveling wave tube.

Carrier Resupply

If the IF carrier is lost in a TD-3 channel the AGC voltage drops and the IF main and limiter amplifiers go to maximum gain. Under this condition circuit noise is amplified and is equal in amplitude across the band. This noise is fed through the modulator to the TWT. Within two repeater sections the TWT amplifiers are saturated at full power with noise spread over a wide band. This noise power, being fed through channel combining and channel separation networks, becomes greater than information in adjacent channel sidebands. Therefore, the loss of the IF carrier in one channel may destroy the information in the adjacent channels. To prevent this from occurring, a carrier resupply panel has been incorporated. The carrier resupply replaces the lost carrier with an IF carrier modulated with either 7 mc or 9 mc within less than 0.1 milisecond and prevents subsequent repeaters from being saturated with noise. This fast reaction time is necessary to prevent a burst of noise from getting into adjacent channels with enough duration to initiate automatic switch actions.

CHAPTER 18 TD - RADIO SYSTEMS

Microwave Generator

The TD-3 microwave generator, (Fig. 18-18), differs from the G-3 model used on TD-2 primarily in its solid state design and closer noise requirements. Basically, the generator consists of a crystal controlled oscillator in the 125 mc region, frequency multiplication to achieve 4 kmc, output amplification and the necessary tuners, filters and waveguide apparatus. Some of the basic objectives are that noise not be greater than 14 db above theoretical at 3 to 4 mc and no greater than 60 db above theoretical near the carrier (4 kmc) at 0.5 watts output.

TD-3 Advantages

A look at the advantages of the TD-3 radio repeater will now show:

1. Better gain-frequency response and greater band width to provide improved capacity.
2. Reduced system noise providing for extended routes to 8,000 miles.
3. Improved reliability due to solid state and improved design.
4. Reduced DC power requirements providing for more economical operation with no forced air cooling required.

The above factors will all contribute to reduce the cost per message mile for a loaded system. The present TD-2 cost is about \$2.46 while the latest estimate for TD-3 is \$1.76.

Trial Installation

There will be two trial installations for the TD-3 system. The first will be in the Memphis to Little Rock route (Figure 12) with main stations at Alexander, Arkansas and Arkabutla, Mississippi. The repeater stations will be at Tucker, Stuttgart, Palmer, and Helena, Arkansas. This trial installation will be TD-3 only and the equipment will be shipped during the last quarter of 1965 and early 1966.

The second trial installation will be an intermix of TD-2 and TD-3 and will run from Sequin to Ennis in Texas. Equipment for this installation will also be shipped early in 1966. Normal production will begin in the fourth quarter of 1966.

MICROWAVE GENERATOR

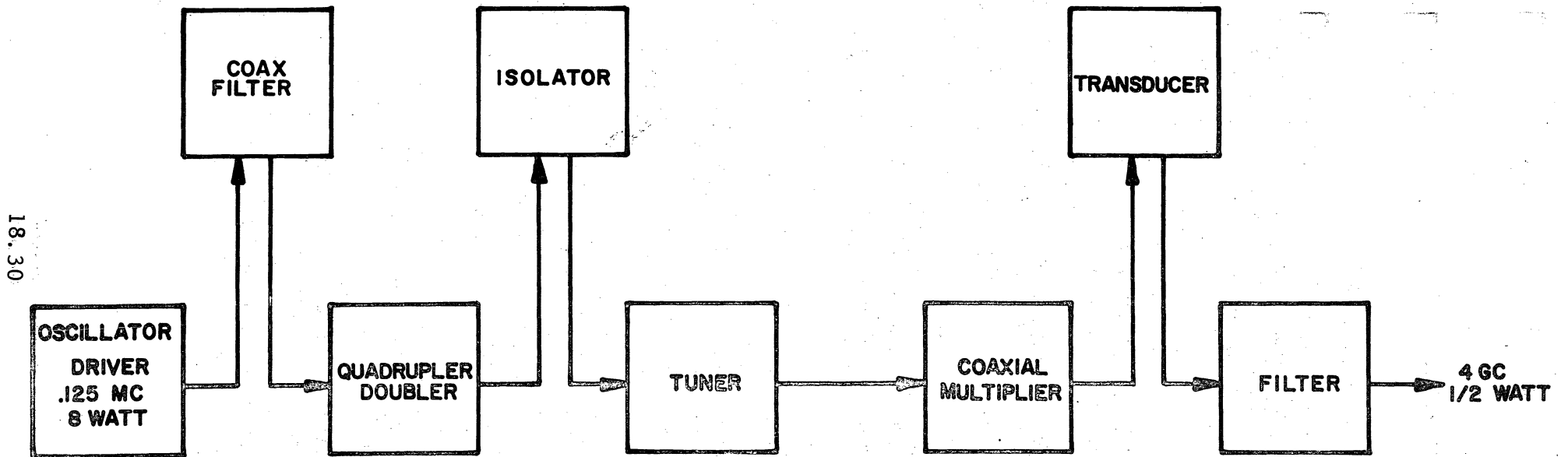

18.30

Fig. 18-18

CHAPTER 19

TH RADIO SYSTEM

19.1 INTRODUCTION

TH radio is a microwave system designed to provide long-haul facilities suitable for handling television, multiplex telephone, or any other wide-band communication signals. The system operates in a common carrier band between 5925 and 6425 mc. Radio waves at these frequencies have propagation characteristics similar to those of light, therefore, for systems such as TH, line-of-sight parts between stations is essential.

The system is set up to provide a maximum of eight broadband radio communication channels and two narrow-band auxiliary channels in each direction of transmission. At a normal repeater point, this will mean a 2-way system with a maximum of eight broadband channels in each direction, six of which are available for regular use, and two reserved for protection.

Each broadband channel accommodates a baseband signal of approximately 10 mc which may comprise 1,860 or more message channels (Potentially 2,220) or a standard 4.5 mc TV signal and 420 or more message channels (potentially 780) in combination. The present capacity of a fully developed TH route would be 11,160 message channels, or 2,520 message channels plus six two-way television channels. (Based on 6 regular and 2 protection channels).

The TH system will use the KS-15676 horn-reflector antenna and circular wave-guide as shown in Fig. 19-7. The horn-reflector antenna is capable of handling a very wide range of frequencies, including the 4,000, 6,000 and 11,000 mc common carrier bands. Consequently, a TH system may be added to an existing TD-2 route if all the stations on this route are equipped with horn-reflector antennas. There are obvious economies in being able to add a new system of large cross-section to an existing route instead of having to construct an entirely new route.

Transmission performance characteristics of the TH system will meet objectives which have been established for 4,000-mile systems. Considerable thought was given into making the TH equipment more time-stable than TD-2 equipment. An automatic protection switching system was developed for use in conjunction with the TH system to assure that transmission performance will be maintained at the desired level despite fading and equipment troubles.

CHAPTER 19 TH RADIO SYSTEM

The TH system differs from the TD-2 system in having an auxiliary channel for automatic switching and radio order, alarm and control purposes as an integral part of the system. On a TD-2 route it is necessary to bring a separate radio system or wire line into each repeater station for order and alarm purposes. The TH auxiliary channel has a capacity of approximately 48 circuits, which is considerably in excess of the number needed for order, alarm and control functions. This additional capacity may be used for short haul toll purposes.

Output power on each TH broad band channel approximates 5 watts and frequency modulation is employed. The narrow band auxiliary radio order channel uses amplitude modulation or possibly single sideband and the output power will be 5 mw. The higher power on the broad band channels is obtained through the use of traveling wave tubes. These tubes require voltages well above 1,000 volts, so that the power supply for the TH system will be quite different from the TD-2 power supply. Batteries are not suitable for such high voltages; instead, rectifiers are employed and rotating machine arrangements similar to those used with coaxial systems are provided to assure continuity of operations.

Preliminary and tentative details of the TH Microwave System are described in the following paragraphs.

19.2 TH FREQUENCY PLAN

Figure 19-1 illustrates the frequency plan for the TH system. This plan provides for a maximum of eight broad band and two narrow band auxiliary channels in each direction. Channels 11 to 18 and 21 to 28, inclusive, are the broad band FM channels for TV, telephone or telegraph services. Channels 10, 19, 20 and 29 are the narrow band AM or SSB auxiliary channels for order, alarm and short haul toll circuits.

Note that all transmitting frequencies are located at one end of the 5925-6425 mc band and the receiving frequencies placed at the other end. The auxiliary channels are situated in the guard band between the broad band transmitting and receiving frequencies as well as in the guard bands between the TH system and other services in adjacent bands. Note also that adjacent broad band channels are alternately polarized to minimize crosstalk. Cross polarization permits overlapping channels slightly so that the effective frequency use is 514 mc in a band only 500 mc wide.

In the TD-2 system it is possible to minimize converging route interference by employing slot frequencies at critical points. With the TH system and its much more intensive frequency utilization, no such alternative is available. It will be necessary, therefore, to lay out TH routes with more care and to choose angles which will not produce excessive interference. The same precautions will henceforth be necessary also in the engineering of new TD-2 routes which may later have TH added.

TH RADIO SYSTEM
FREQUENCY ALLOCATION AND
POLARIZATION PLAN

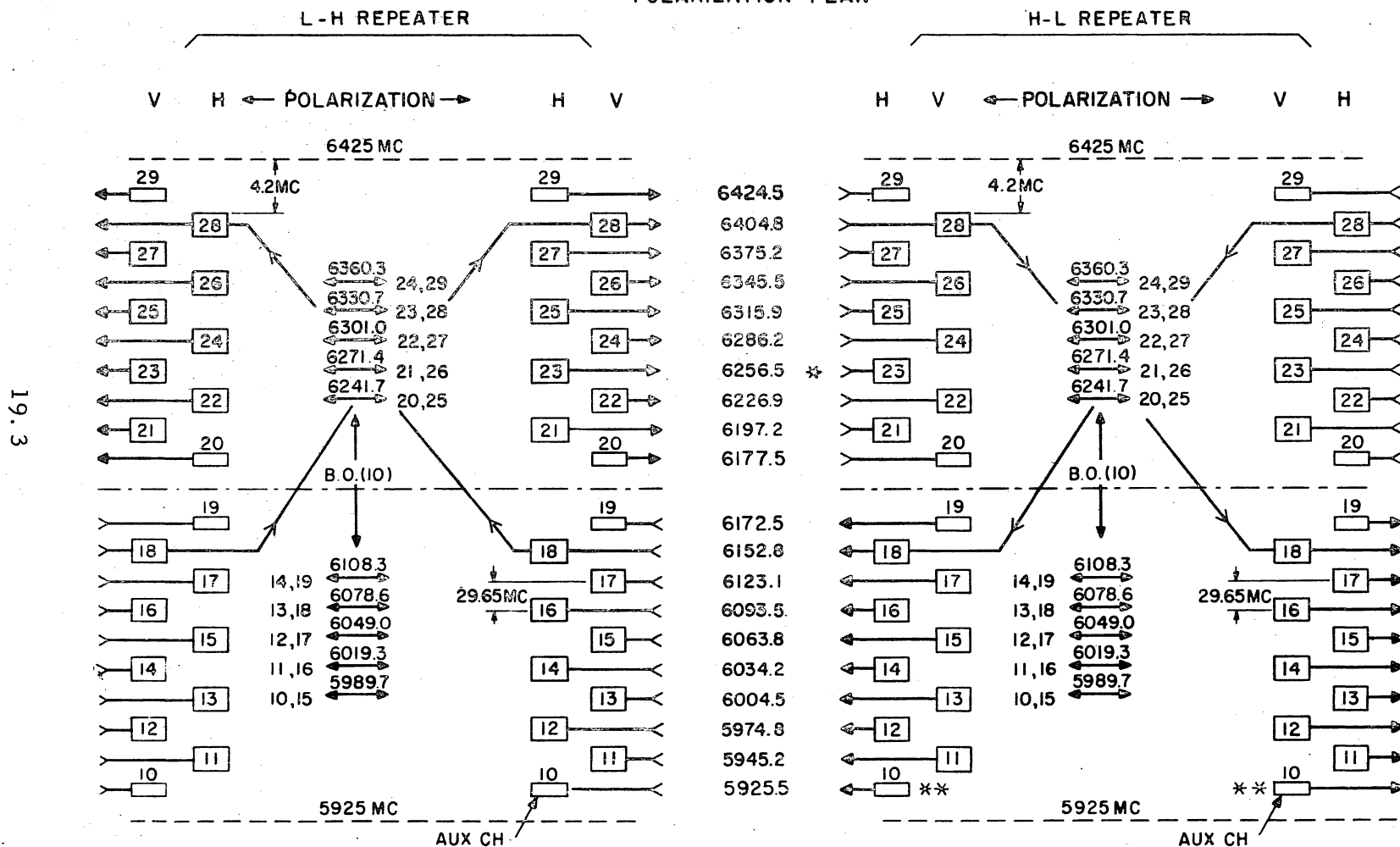

19.3

CHAPTER 19 TH RADIO SYSTEM

* 6266.5 MC WHEN CHANNEL 23 IS USED AS AN AUX CHANNEL

IF = 74.1
AUX IF = 64.2 MC

** IN A TWO ANTENNA SYSTEM, CHANNEL 10 IS THE SAME POLARIZATION AS CHANNEL 19

Fig. 19-1 - TH Radio System, Frequency Allocation and Polarization Plan

TH BASEBAND SIGNALS

TH-TELEVISION ONLY

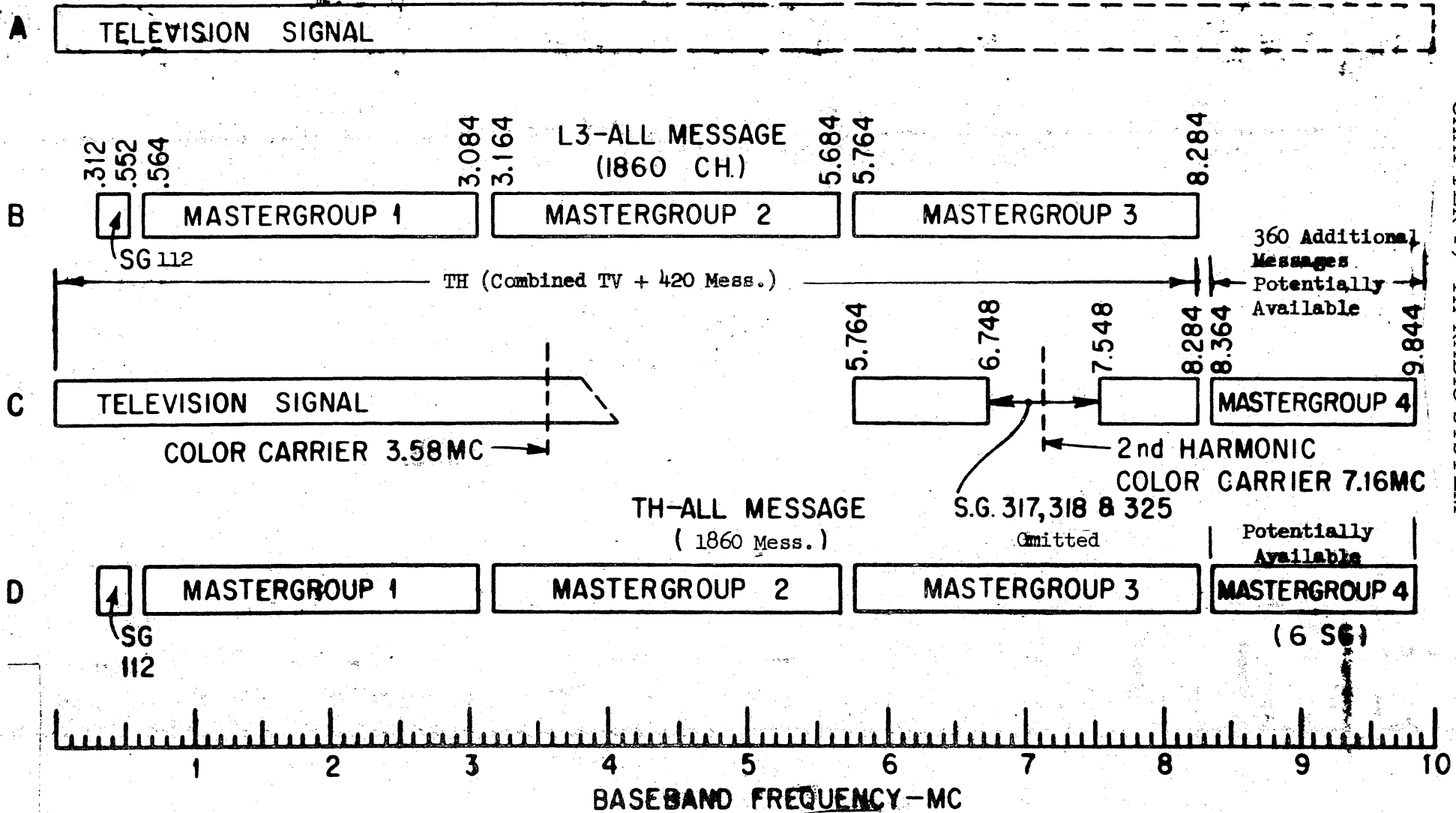

Figure 19-2

19.4

CHAPTER 19 TH RADIO SYSTEM

Channelizing

Figure 19-2 shows the 10 mc TH baseband, designed to accommodate a theater television signal. Figure 19-2 illustrates the normal line frequency assignments for the L3 carrier, indicating that L3 terminals can be employed with the TH system. In actual practice, however, the standard L3 signal would not be applied to a TH line except on an emergency "make-good" basis, owing to pilot, line regulator and interconnection level problems.

It is planned to transmit not only TV or telephone, but also combined TV and telephone signals over the TH system. The combined signal, as portrayed in Figure 19-2 will require a multiplex terminal similar to the L3 terminal except that it will translate master groups to the locations shown. The TV signal is placed at the low end of the band because a microwave system is capable of transmitting such signals without a frequency translation. Also, modulation products are less troublesome with message signals above TV.

For the sake of flexibility and standardization of channelizing equipment, it is proposed to arrange multiplex terminals for TH to be capable of producing the frequency translations shown in Figure 19-2. The user will then have the option of equipping master groups 1 and 2 or providing a TV channel (and omitting supergroups 317, 318 and 325). Note that master groups 1, 2 and 3 and supergroup 112 have exactly the same frequency assignments as in the L3 coaxial system.

In figure 19-2 the 1.5 mc gap between the TV signal and the adjacent master group is required for crossover of the cutoffs of a high-pass - low-pass filter pair which separate the telephone and TV frequencies.

The gap at 7.2 mc in master group 3, obtained by omitting supergroups 317, 318 and 325, is required to avoid interference to message circuits from the second harmonic of the TV color subcarrier.

The existing 10 mc channel bandwidth is of sufficient width to accommodate an additional 360 message channels. However, this potential increase in capacity will not be available until supplementary techniques are devised and incorporated into the TH System to meet noise objectives.

19.3 MEETING TRANSMISSION OBJECTIVES

Intermodulation noise in the TH system is primarily a result of transmission gain and phase distortion. Some intermodulation noise comes from non-linear conversion of amplitude into phase modulation, largely from the traveling wave tube amplifier. In the TH system the spurious phase modulation due to amplitude modulation is minimized by including a limiter in each repeater to reduce amplitude modulation.

CHAPTER 19 TH RADIO SYSTEM

The traveling wave tube used in the RF amplifier is a broad band device. It has very little phase distortion as compared to the TD-2, in which the resonant frequencies of the tube cavities in the RF amplifier vary with ambient temperature and produce systematic changes in delay distortion from repeater to repeater.

The IF amplifier for the TH system is being designed with an emphasis on stability of components in order to minimize the dependence of transmission distortion on tube parameters. Most of the out-of-band frequency shaping will be provided by passive networks.

The carrier/noise ratio at the TH converter is about 13 to 15 db better on the average than TD-2. This margin could be used to improve noise performance or to increase message handling capacity. The latter alternative has been chosen, so that the fading performance of the TD-2 and TH systems will be almost identical.

Filters and Equalization

The TH system is engineered for a maximum of 16 pairs of FM terminals in tandem on a 4,000-mile circuit. Because combined TV and telephone signals will be handled, high-pass - low-pass filter pairs will be required to separate the telephone and TV. There is one filter per FM terminal, or a maximum of 32 filters in tandem for a 4,000-mile circuit. The low-pass filters will be provided with built-in delay equalization. Each TV side leg or terminal leg will be equipped with an additional low-pass filter to cut down ringing.

Through circuits will be equalized at I. F. on a switching link basis. When a protection switch is made, there will be slight variations in the overall 4,000-mile circuit which will not be mopped up. There may be provisions for mop-up at baseband from terminal to terminal.

19.4 MICROWAVE CARRIER SUPPLY

The TH system uses a common carrier supply which will furnish ten transmitting and receiving beat frequencies for 16 broad band receivers, 16 broad band transmitters, 4 narrow band auxiliary transmitters and 4 narrow band auxiliary receivers. Four frequencies, 29.7, 59.3, 6049, and 6301 mc, which are derived from a 14.83 crystal through multipliers, are supplied from this system. The 6049- and 6301-mc microwave supplies are used along or in combination with the 29.7- or 59.3-mc shift frequency supplies to provide the beating oscillator or carrier frequencies required at the transmitter or receiver modulators. Where the desired carrier frequency is a sum or difference of 6049 or 6301 and 29.7 or 59.3, a carrier supply (shift) modulator is provided on the appropriate transmitter or receiver unit wherein the microwave carrier and shift frequency are combined.

CHAPTER 19 TH RADIO SYSTEM

In order to assure the reliability necessary in a common carrier supply system, two carrier supply generators, powered from separate primary sources, are provided, one regular and one standby. Both generators operate continuously, with the regular always in service except in case of a failure when the standby will take over.

Crystal oscillators are provided in duplicate. A frequency comparator monitors the outputs and gives an alarm if either drifts. If one fails, the other will be automatically switched into service by a 223-type switch. Other 223-type switches are used to transfer the shift frequency outputs from regular to standby carrier supply. Switching of microwave frequencies is accomplished with ferrite gyrators. Switching time is in the order of 5 milliseconds. There is also a "slow switch" arrangement which will monitor all the frequency multiplying chains and switch a whole chain whenever the output of one stage gets low. Maintenance switching is designed to complete the maintenance switching operation in 200 to 300 microseconds.

19.5 TH TRANSMITTER

The microwave transmitter used in the TH system will combine an IF signal from a receiver or an FM transmitter with a local carrier supply frequency. The IF and local carrier supply signals are combined in the Transmitter Modulator and amplified by a traveling wave tube. The output at +37 dbm is fed to the antenna system. A block diagram of the transmitter is shown in Figure 19-5. The appropriate carrier supply frequency for a particular transmitter is obtained by combining in the Shift Modulator one of the microwave frequencies and one of the shift frequencies from the station carrier supply.

The TH antenna is capable of radiating 12 kmc, so that a harmonic filter is required after the traveling wave tube to reduce the second harmonic. The isolator is required between the traveling wave tube and the antenna because the tube has a low return loss and might otherwise tend to produce echoes in the waveguide system.

19.6 TH RECEIVER

The TH receiver combines in a Receiver Modulator the incoming microwave signal and a local carrier frequency, and produces an IF signal of 74.1 mc. As in the transmitter, the beat frequency is produced by a Shift Modulator in which one of the two basic microwave frequencies and one of the two basic shift signals from the station's carrier supply are combined. The approximate equalization for the repeater station is included in the receiver. The precise equalization, as mentioned previously, will be done on a mop-up basis. The receiver block diagram is shown in Figure 19-6.

TH MICROWAVE CARRIER SUPPLY

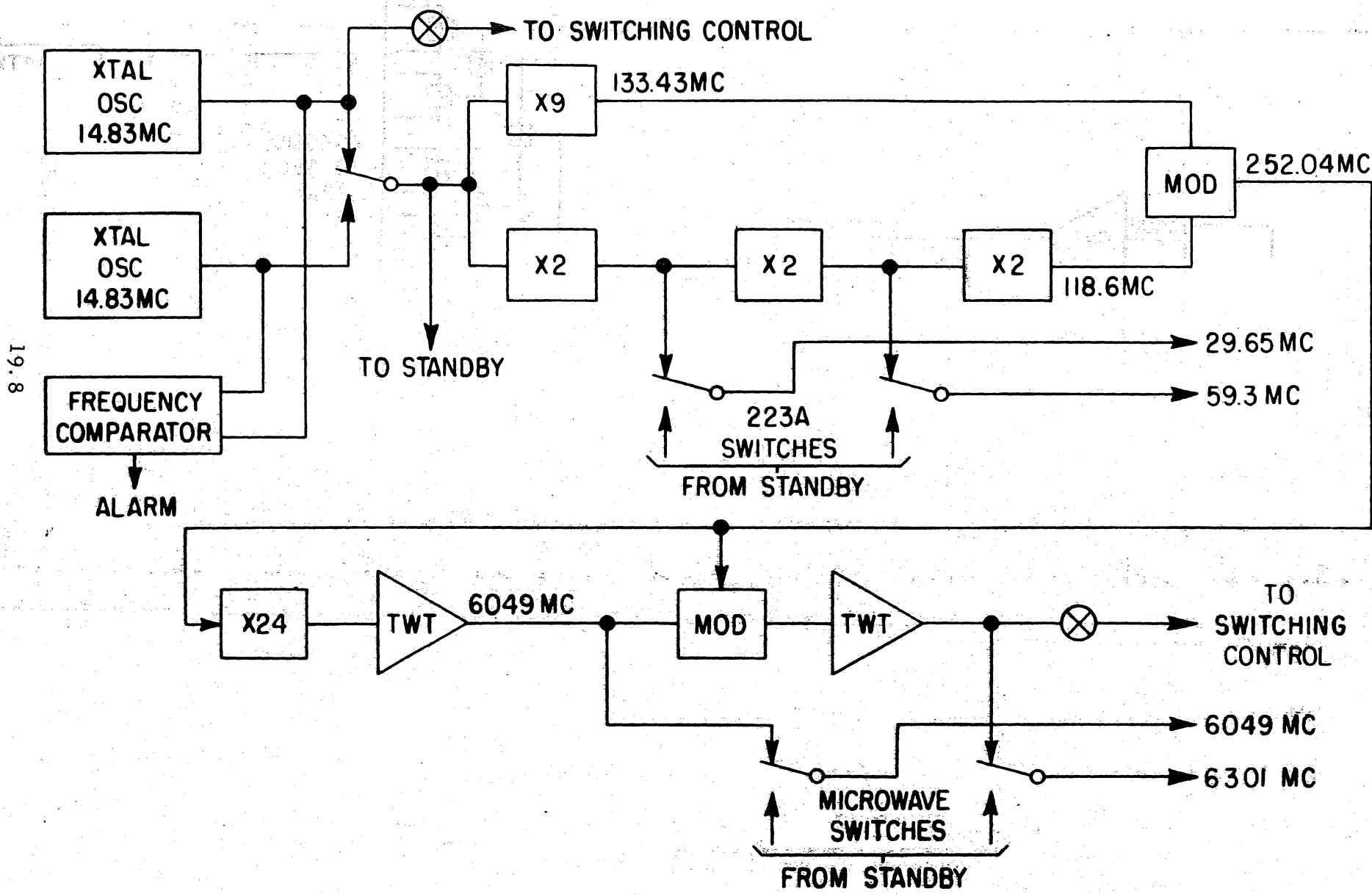

19.8

CHAPTER 19 TH RADIO SYSTEM

Figure 19-3

19 TH COMMON MICROWAVE CARRIER SUPPLY

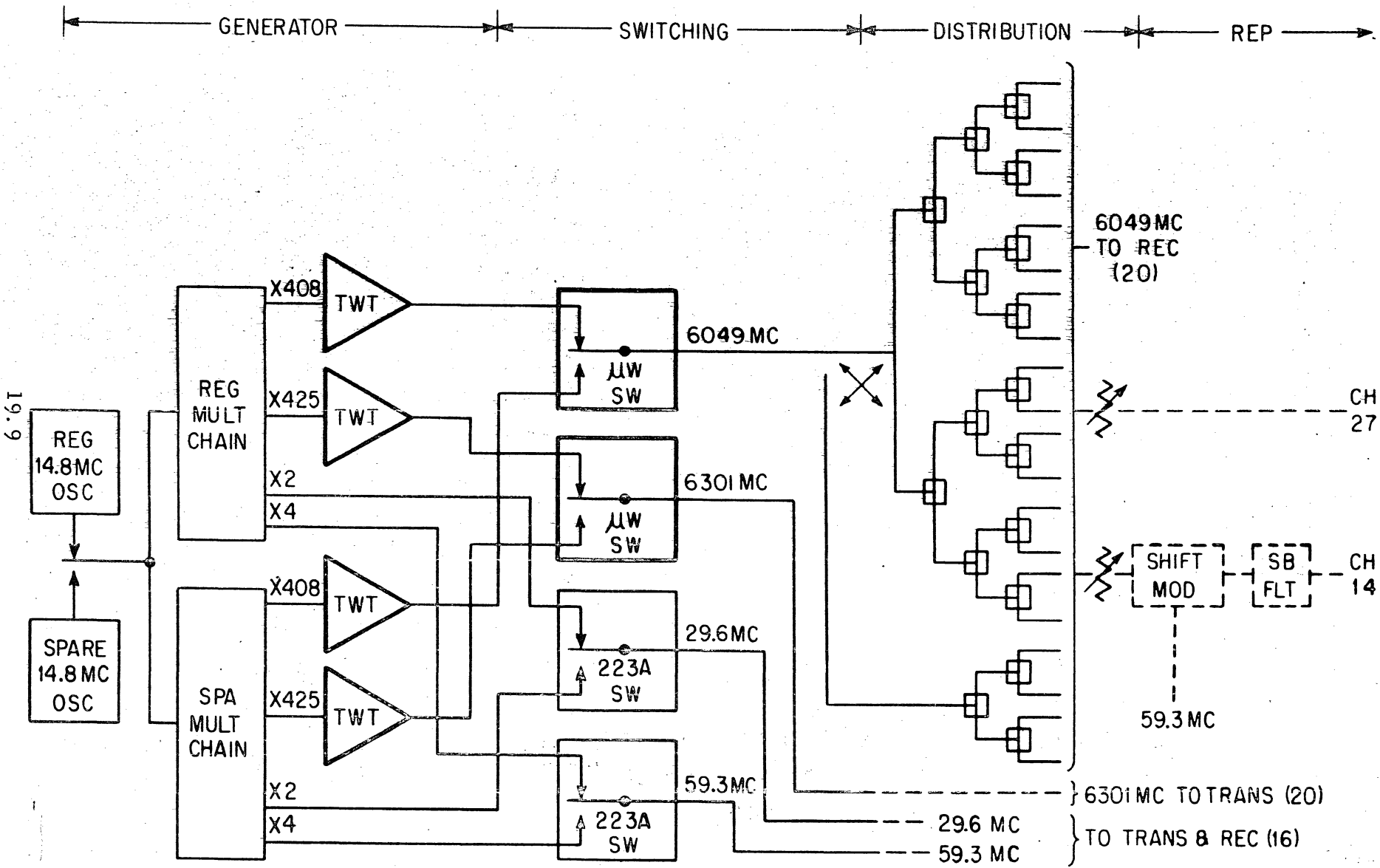

CHAPTER 19 19 TH RADIO SYSTEM

Figure 19-4

TH TRANSMITTER

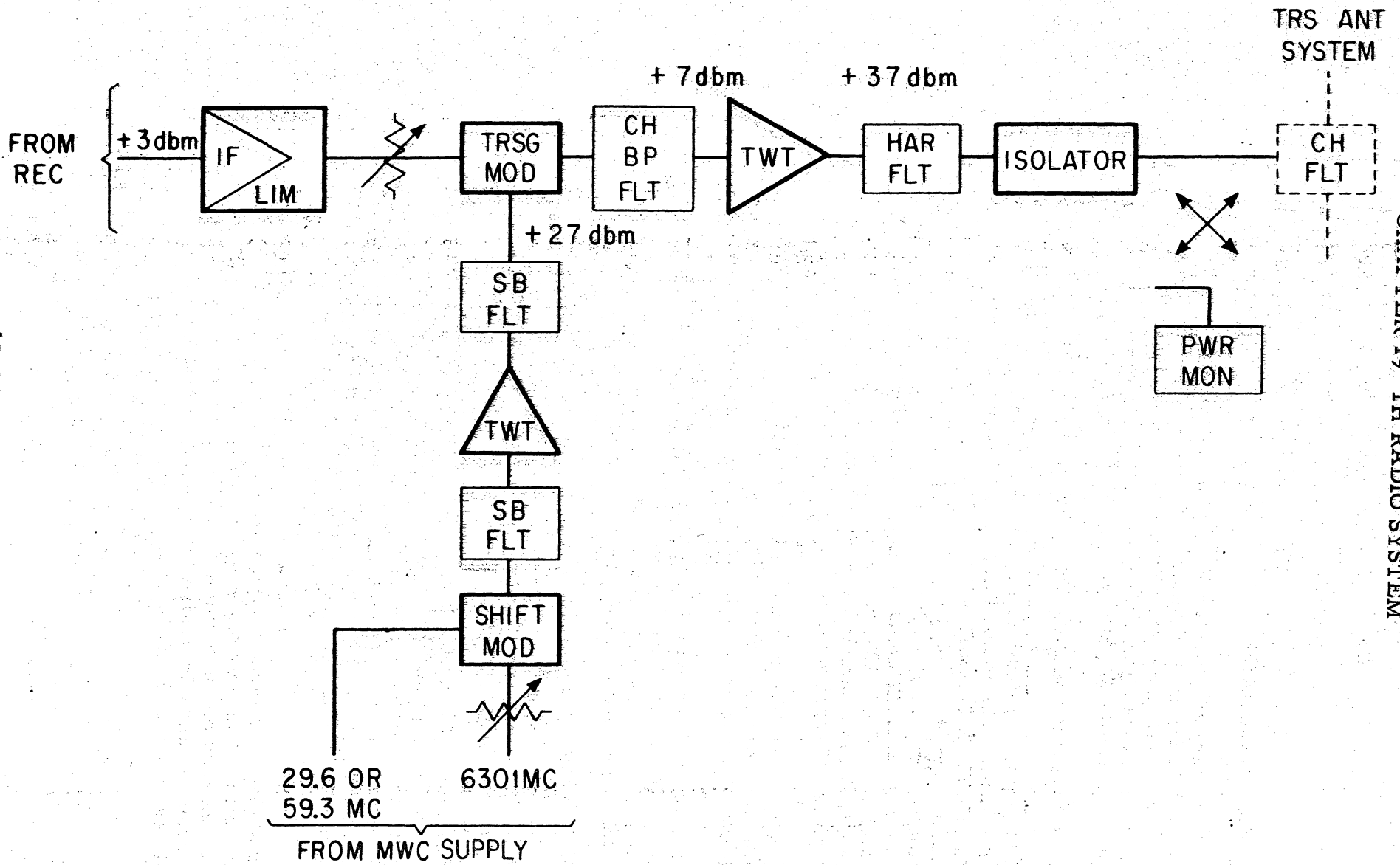

19.10

CHAPTER 19 TH RADIO SYSTEM

Figure 19-5

CHAPTER 19 TH RADIO SYSTEM

19.7 FM TERMINALS

The TH system employs an FM terminal transmitter and an FM terminal receiver similar in design and function to those used with the TD-2 system. It is, of course, necessary to meet more stringent performance requirements with the new terminals in order to handle the larger number of telephone circuits and the wide band TV signal.

19.8 AUXILIARY RADIO CHANNEL

The TH auxiliary radio channel is a low powered (5 mw) AM or SSB microwave system. Operation at 5 mw is possible because the number of circuits to be handled is small and the maximum circuit length is short. The principal function of the auxiliary channel is to provide circuits for automatic switching, order, alarm and control purposes for the TH system. The circuit requirements for these purposes are small, however, so that the majority of the 48 circuits will be available for short haul toll use. Type ON channelizing is employed and maximum circuit length approximates 200 miles. Circuits can be dropped or added at any repeater.

In order to make use of as much standard TH equipment as possible, including the microwave carrier supply, a special intermediate frequency of 63.6 mc is being employed. One traveling wave tube is used instead of two.

Referring to Figure 19-1, it will be seen that there are two auxiliary channels in each direction. One is used as a regular and one as a protection channel. The chance of a simultaneous fade on both channels is negligible, as the frequency separation is greater than 240 mc.

19.9 ANTENNA AND WAVEGUIDE

The TH system employs the KS-15676 Horn-Reflector antenna and circular waveguide, shown in Fig. 19-7.

Three types of coupling devices are provided for connecting the TH equipment to the circular waveguide installation. If a two-antenna per direction arrangement is used - one antenna for transmitting and one for receiving - and the number of two-way channels does not exceed four, then a simple rectangular-to-circular waveguide transducer may be employed. This transducer is similar to the ED-59410-90 transducer available for the TD-2 (4 kmc) system.

For a single antenna arrangement or for a two-antenna arrangement handling more than four one-way channels, it is necessary to employ both polarizations on each antenna. A special coupler will be required for this purpose, similar in design to the 11A coupler available for the TD-2 System and described in P. E. L. 5725.

TH RECEIVER

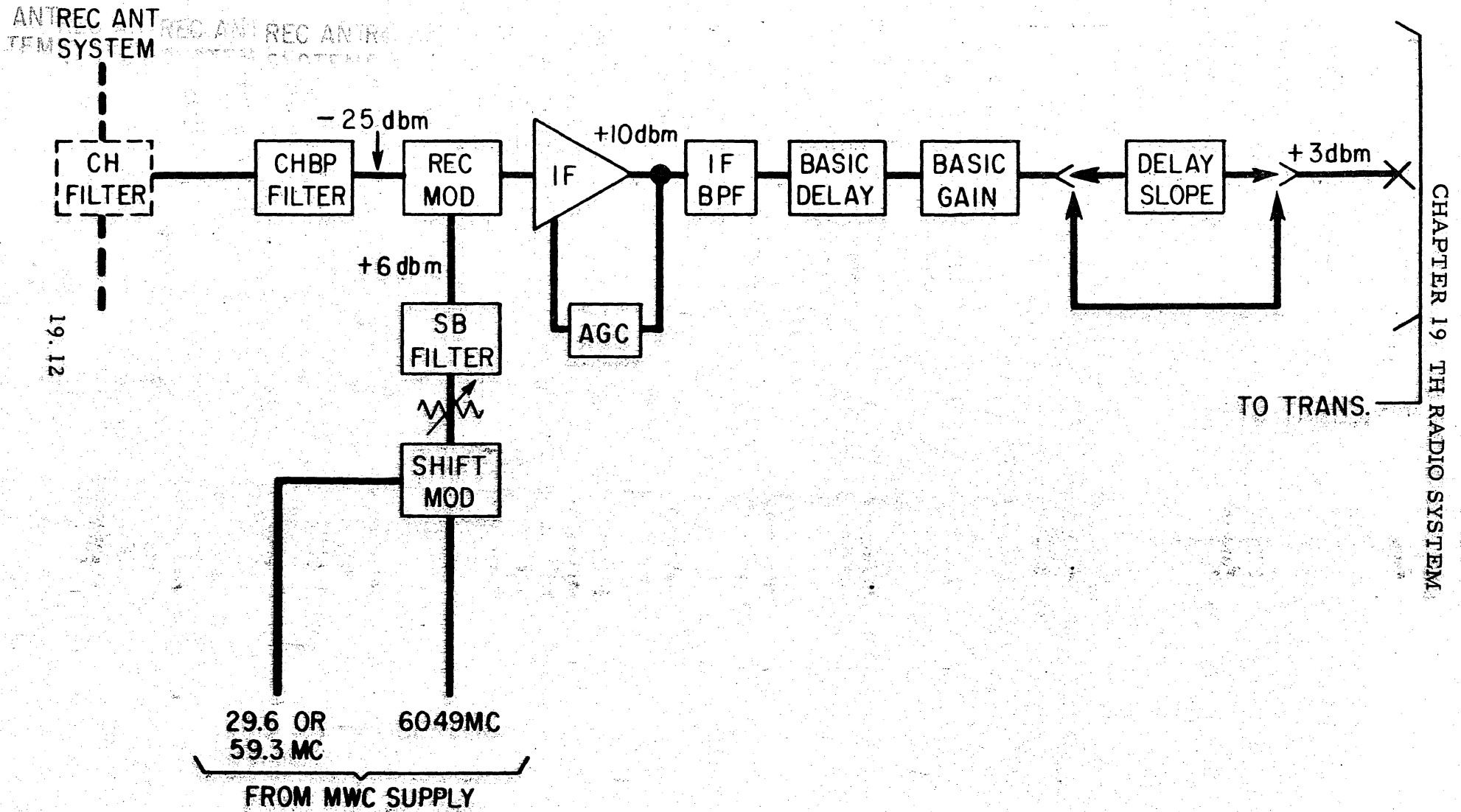

Figure 19-6

CHAPTER 19 TH RADIO SYSTEM

Where it is planned to use a common antenna and circular waveguide installation for both TD-2 and TH systems, a systems combining network will be required. This network, described in P. E. L. 5438, will also make it possible to connect a TJ (11 kmc) system to the circular waveguide run and horn-reflector antenna.

19.10 TH REPEATER

In the foregoing sections the various components of the TH repeater have been described individually. To produce a repeater these components will be combined as illustrated in Figure 19-8. The channel separation networks shown are similar in design to those used in the TD-2 system.

Radio Repeater Stations are stations which provide transmission gain or maintain line-of-sight paths, or do both. They comprise the majority of the stations in any large system and are normally unattended. When any facility beyond fixed equalizers or pads is added at a repeater station, such as a television drop, it will then be classified as a main station.

The spacing of main stations along the radio relay route depends partly on traffic, maintenance, or other considerations. On an average, however, a main station occurs every fifth or sixth station. This is a maintenance requirement since sections of the radio system between main stations will normally be operated as a unit. In the arrangements of the TH system, it is expected that not more than ten radio links will be permitted without a protection switching station.

Normally end and intermediate main stations will have similar facilities for switching, testing, and branching. At end main stations, all of the regular channels terminate in baseband facilities, whereas in intermediate main stations the channels may terminate or be connected through the station at intermediate frequency.

19.11 COORDINATION AND INTERCONNECTION OF TH AND TD-2

The intermediate frequency band of the TD-2 system extends from about 60 to 80 mc. The TH intermediate frequency band is approximately 58 to 90 mc. Both systems use a maximum deviation of + 4 mc. It is possible, therefore, to transmit from a TD-2 system into a TH system and make the interconnection at intermediate frequency. Obviously, however, a connection from a TH system into a TD-2 system cannot be made at IF on account of the narrower band width of the TD-2 system.

As discussed or implied in preceding sections, TD-2 and TH systems can be installed on the same route, using common sites, common buildings, towers, antennas and waveguides. Power supplies, alarm and control equipment and automatic switching for the two systems would be separate, although some of the spare circuits on the TH auxiliary channel could be used to provide order, alarm and control circuits for the TD-2.

CHAPTER 19 TH RADIO SYSTEM

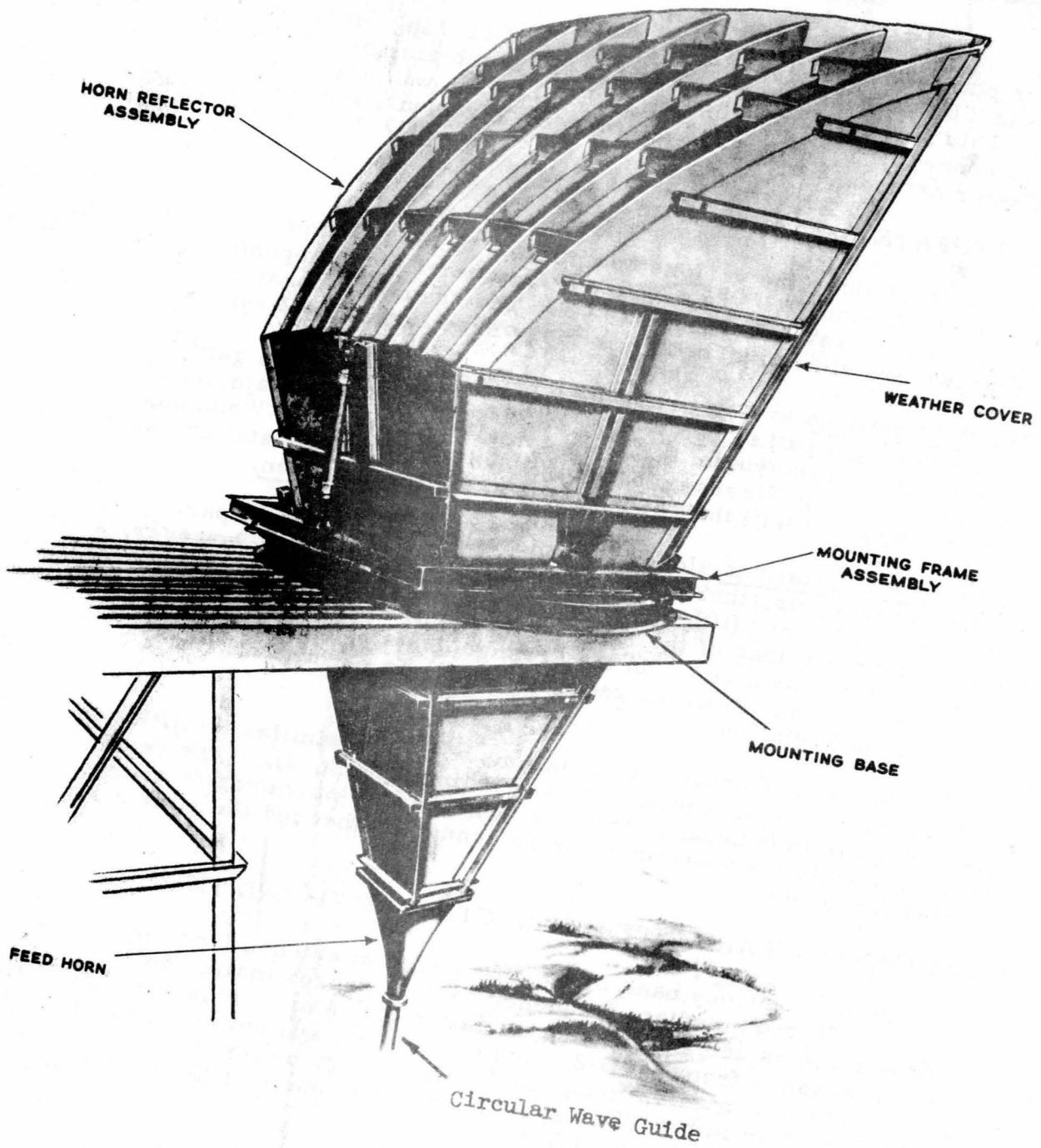
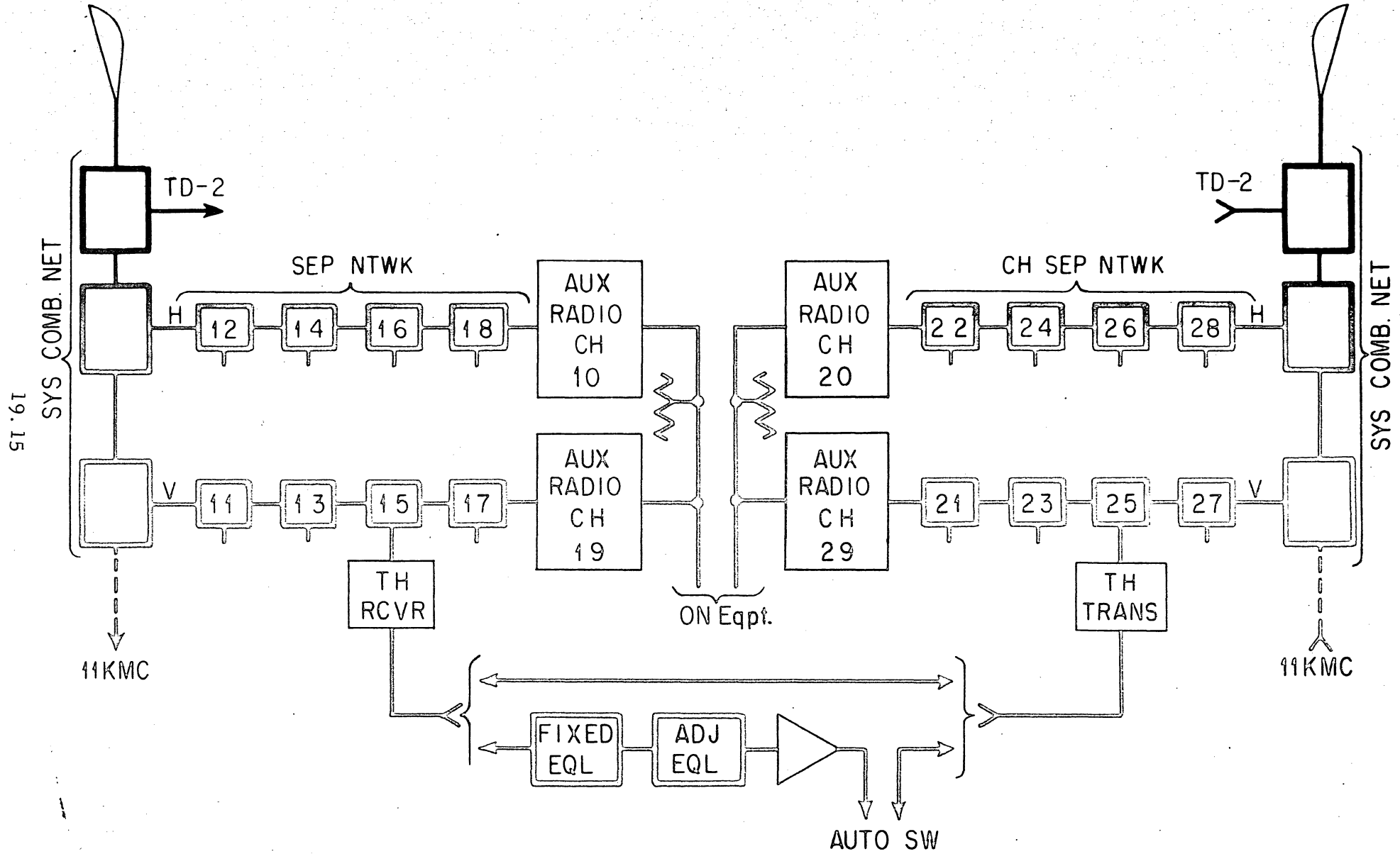

Fig. 19-7 - KS-15676 Horn-Reflector Antenna

TH REPEATER STATION



19.15

CHAPTER 19 TH RADIO SYSTEM

Figure 19-8

CHAPTER 20

TJ RADIO SYSTEM

20.1 INTRODUCTION

The TJ Microwave system provides short-haul line-of-sight facilities for frequency modulated microwave transmission of monochrome or color television signals, multiplex telephony, or other broadband communication signals. The system operates in the common-carrier frequency band between 10,700 and 11,700 megacycles, and provides as many as six broadband 2-way communication channels. The number of message circuits obtainable in a single broadband channel of TJ radio is a function of many variables. The length of the system, its signal-to-noise ratio, fading margin, intermodulation products, the delay equalization, and the permissible degradation of transmission are some of the more important factors.

In TJ radio, each 2-way broadband channel is designed to transmit 96 ON2 type message circuits, or 240 message circuits (lower super groups) of L carrier over ten hops for a total distance of about 200 miles. Suitable outside supplier message carrier equipment may also be used. In television service each radio channel is designed to transmit one standard monochrome or NTSC color television signal over six hops for a distance of about 100 miles. The repeater spacings for either message or television application will average between 15 and 25 miles, depending upon the terrain, over-all economies, fading, the expected rate of rainfall, and other microwave considerations.

For maximum reliability and protection against multipath fading and equipment failure the TJ radio system can be operated as a one-for-one frequency diversity system. In this system two channels are used in pairs and a diversity switch and transmission unit provides facilities for comparing the signals from both channels and through a logic or control circuit determines which channel should be used. When operated in this manner, as it will for general Bell System use, a fully loaded system provides three working and three protection channels in each direction of transmission.

The basic element of the TJ system is the transmitter-receiver bay which includes a transmitter, receiver, and associated power supply operating from 117 volts ac. All equipment and adjustments are accessible from the front. Plug-in equipment units are used to reduce down-time and facilitate maintenance. Equipment components are derated for extended life and reliability. Waveguide connections to the bay are made with flexible waveguide to facilitate installation. The D1 alarm system and the required number of diversity switch units, plus the associated 117 volt ac operated power supplies are contained in a separate order wire, alarm, and control bay.

CHAPTER 20 TJ RADIO SYSTEM

A single antenna with dual polarization is used in each direction of transmission for simultaneous transmission and reception. As many as six transmitters and six receivers may be connected to a single antenna through channel dropping and combining networks. The antenna system of TJ radio must be engineered to obtain line-of-sight transmission with adequate clearance. There are several methods of arranging the antenna systems, depending on terrain, building, and other considerations:

- (a) If the radio equipment is located on a hill or in a tall building, where there is adequate clearance, the parabolic antenna may be located on the building roof, or affixed to a side wall and directed horizontally to the distant station.
- (b) If there is inadequate clearance, a tower will be necessary, in which case there are two methods which can be used:
 - (1) The antenna can be mounted on the radio station roof just above the radio equipment, and directed vertically to a reflector on the tower which mounts at approximately 45 degrees. This reflector redirects the beam horizontally to the next station. It is expected that this method will cover the majority of installations requiring towers.
 - (2) The parabolic antenna may be located on the tower and pointed directly toward the distant station. This arrangement requires long waveguide runs with accompanying greater attenuation. However, there will be applications where reflectors are not practical where this method should be used.

Material covered in later paragraphs will discuss in greater detail the tower and antenna considerations.

The beam width of TJ radio is comparatively narrow and must be directed within closely held margins. Rigidity of construction is a requirement which has been designed into the antenna and towers, and must be considered in the design of any supporting structures not controlled by this or supplementary specifications.

20.2 TJ FREQUENCY PLAN

Figure 20-1 illustrates the frequency plan for the TJ system.

In order to prevent interference from other TJ stations on a particular route, and to insure that a given receiver will demodulate radio energy from only one radio transmitter the TJ system uses 24 radio channel frequencies and two polarizations.

CHAPTER 20 TJ RADIO SYSTEM

The 1,000-megacycle frequency band between 10,700 mc and 11,700 mc is divided into 24 channels with 40 mc separation between midchannel frequencies. (See Table A.)

On any one system hop alternate channels (12 total) having 80 mc separation are used. These channels are alternately polarized giving 160 mc separation between adjacent channels of the same polarization. The adjacent radio paths use the alternate 12 channels resulting in 40 mc separation between channels on opposite sides of a repeater station. To provide adequate frequency separation between transmission and receiving at any one station, the upper half of the frequency band is allocated to transmitting when the lower half is receiving. Since transmitters work into receivers of the same frequencies, alternate stations will necessarily be inverted, with receiving in the upper half and transmitting in the lower half of the frequency band. In addition, reference to Table A will show that the separation between the two channels adjacent to midband is 90 mc rather than 40 mc. This fulfills the requirement for a minimum separation of 130 mc ($90 + 40$) between any transmitting and receiving channel combined at one antenna.

20.3 MEETING TRANSMISSION OBJECTIVES - MULTIPATH FADING

Multipath fading for the 11 KMC frequency band (TJ) is expected to be essentially the same as path fading in the 4 KMC (TD-2) and 6 KMC (TH) frequency bands. The number of fades per given period is expected to be greater for the 11 KMC band. Multipath fading is basically an atmospheric problem where the theoretical path loss for a microwave signal varies from the line of sight path calculation due to changes in air temperature and humidity. Since the fading pattern varies with frequency it has been found that two microwave signals in the 11 KMC band will have fade at different times if displaced by 240 MC. This makes it possible to obtain a good toll quality circuit for a long period of time using the frequency diversity system with a signal comparator switching unit on the receiving end of a radio link.

Diversity Switching is used with the TJ radio system to provide a one for one spare radio path. This affords protection against equipment failure and fades. The transmitting portion of the diversity switch allows two TJ radio transmitters to be fed with the same baseband information and it also adds a 3,700 cycle pilot tone to the transmitted signal. The receiving side of the diversity switch may be divided into two sections. In one the 3,700 cycle pilot tone is sensed from each receiver. If the pilot tone is lost, the channel is assumed to have failed and will be locked out to prevent the drop side from being connected to a bad channel. In addition an appropriate alarm is transmitted. The second section of the diversity switch panel consists of a logic circuit which determines the signal strength at each receiver. This circuit will cause the drop side to be connected to the best radio path at all times. It is this portion of the diversity circuit which removes one of the large objections to 11 KMC operation, namely the effects of fades.

CHAPTER 20 TJ RADIO SYSTEM

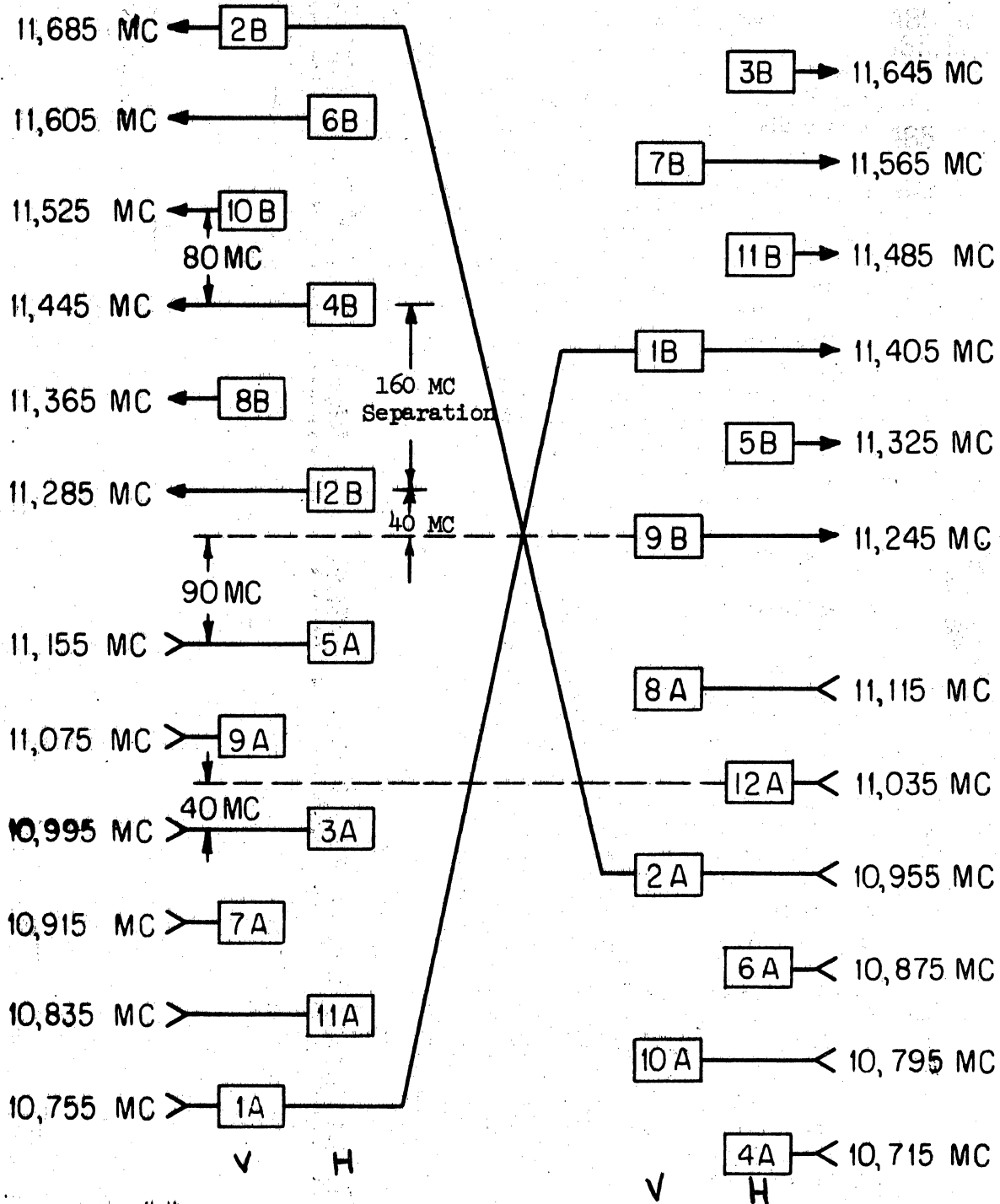

NOTE: "A" designated channels are interconnected to correspondingly numbered "B" channels as illustrated.

Usual channel growth on a route will be in advancing numerical order.

Figure 20-1 TJ Frequency Plan

CHAPTER 20 TJ RADIO SYSTEM

TABLE A

Channel Center Frequency in KMC KMC = 1,000 mc	Channel	
	Number	Letter
10.715	4	
10.755	1	
10.795	10	
10.835	11	
10.875	6	
10.915	7	A
10.955	2	
10.995	3	
11.035	12	
11.075	9	
11.115	8	
11.155	5	
11.245	9	
11.285	12	
11.325	5	
11.365	8	
11.405	1	
11.445	4	B
11.485	11	
11.525	10	
11.565	7	
11.605	6	
11.645	3	
11.685	2	

The "TJ" terminal station frequency arrangement is derived from the following data:

- A-1) - All channels transmitting North or East have odd numbers.
- 2) - All channels transmitting South or West have even numbers.
- B - All channels transmitting in one direction on a specific hop are designed A; in the opposition direction B.
- C - Two channels within a diversity group are oppositely polarized.

CHAPTER 20 TJ RADIO SYSTEM

Meeting Transmission Objectives - Polarization

With the exception of a short length of circular waveguide at the antenna and the antenna feed itself, rectangular waveguide is used exclusively by the TJ radio system. In such waveguide at wave lengths less than cutoff value, the electric field representing the dominant mode is transverse to the guide axis and extends between the two walls that are closest together.

In circular waveguide the dominant circular mode is introduced into the guide will run across the tubing.

It is possible by the use of a special piece of waveguide plumbing to introduce two polarizations into a section of circular waveguide. This unit for the 11 KMC band is designated as a 1405A dual polarizer. When applied to free air transmission the two types of polarizations are known as horizontal where the electric field will be propagated parallel to the earth's surface and vertical where it will be perpendicular to the earth's surface. Hence in any given TJ transmission path as mentioned above, the signal from one diversity pair will be cross polarized.

20.4 "TJ" TRANSMISSION

The Western Electric type 445A Reflex Klystron oscillator is the heart of the TJ transmitter. This klystron has a normal operating frequency range of 10.7 to 11.7 KMC (KMC = 1,000 MC) with a power output of 1/2 watt. The klystron assembly as applied to TJ radio is air cooled by a self contained blower. The 445A is essentially a single cavity klystron which produces an F.M. signal by application of an amplified base band signal to its repeller.

It might be well to mention at this point the ferrite isolator, a radio check valve, - since these units are used throughout the TJ system.

In brief the ferrite isolator (Western Electric IA) is a special section of waveguide containing a section of ferrite material. The entire unit is then placed with the field of a strong permanent magnet. The resulting device will pass microwave frequencies quite freely in one direction but will show a return loss approximately 30 DB. These units are placed in the waveguide configuration just after every transmitting klystron to prevent reflected energy from causing klystron pulling (i. e., change in normal operating frequency due to the insertion of a delayed wave or new frequency into a klystron cavity.) These units are also placed in the waveguide connecting the transmitter and receivers of a TJ system in a common antenna system when any receiver from the 7 to 12 group. This is required to eliminate beat frequencies produced by the combination of several receiver local oscillators.

CHAPTER 20 TJ RADIO SYSTEM

The TJ radio transmitter - receiver bay, Figure 20-2 provides the equipment for a single one way channel at a repeater station, or the transmitting and receiving equipment for separate channels at a repeater or at a terminal point. The equipment consists of a single frame which has two fundamental divisions:

- (a) Receiver
- (b) Transmitter

The equipment is so arranged that either a transmitter, receiver, or both may be furnished. A common power supply is provided on the bay, having a strapping arrangement to keep the load relatively constant regardless of the equipment arrangement.

20.5 TRANSMITTER OPERATION

Transmission of a baseband signal begins at some V.F. frequency device - telephone, telegraph, or pulse system such as SAGE. These V.F. signals are passed through a multiplexing device which combines up to 240 channels into one broad band spectrum. The signal then enters the 124 ohm baseband amplifier and is amplified sufficiently to deviate the transmitting klystron to a maximum of 8 MC peak to peak. A portion of the transmitted signal then enters the transmitter automatic frequency control circuit which serves to keep the transmitter on frequency by means of an electromechanical servo system and an Invar cavity tuned to the operating frequency. This portion of the transmitter also contains a directional coupler for sampling a small amount of power to provide an indication of output power and to energize alarms in the event of output failure.

Next, the transmitted signal enters the isolator which transmits freely in the forward direction while absorbing reflections arising in the waveguide and antenna system which would otherwise distort the FM microwave signal. At the output of the isolator, a waveguide switch is provided to permit testing and adjusting the transmitter without inadvertently emitting an interfering signal. The transmitted signal then reaches the channel combining network, where it is combined with the other transmitted frequencies from the associated transmitter bays. The combined signals are fed into the polarization combining network which combines the horizontally and vertically polarized signals. The composite signal is transmitted by means of circular waveguide to the antenna system. See figure 20-3.

20.6 RECEIVER OPERATION

At an antenna the incoming microwave signal from a distant station may consist of from one to six radio channels. This complex signal is received by either a paraboloidal antenna directed toward the next station or a combination of an elevated microwave reflector and its associated paraboloidal antenna. The signal is then carried through circular waveguide to a

CHAPTER 20 TJ RADIO SYSTEM

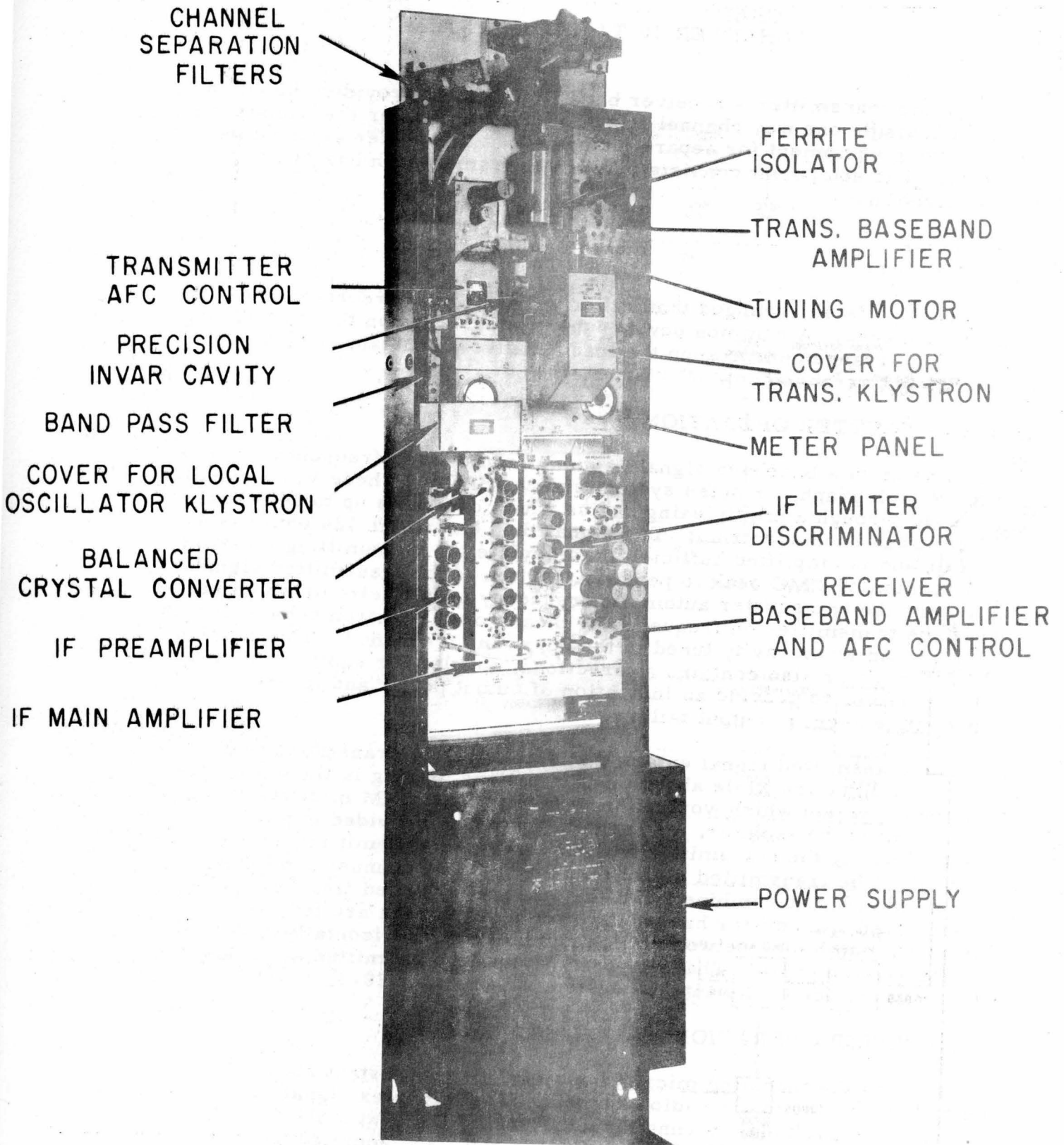

Figure 20-2 TJ Radio Transmitter-Receiver Bay

CHAPTER 20 TJ RADIO SYSTEM

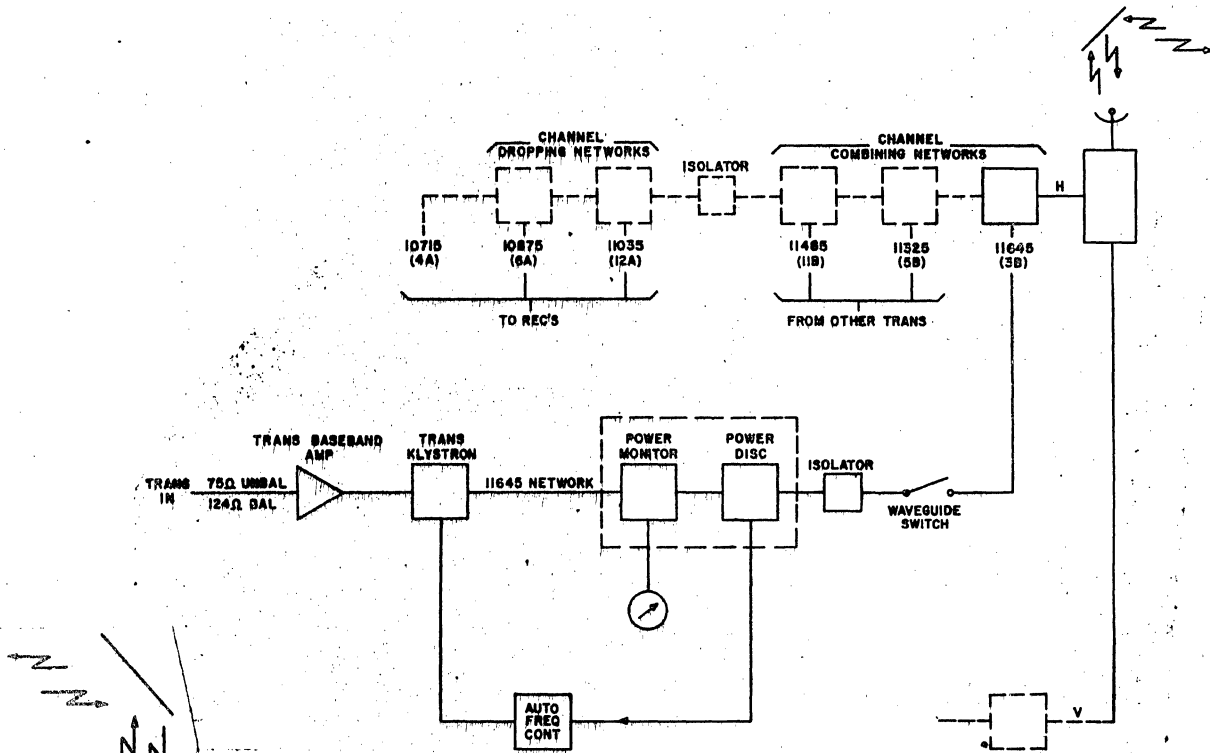

Fig. 20-3 - Transmitter Block Diagram

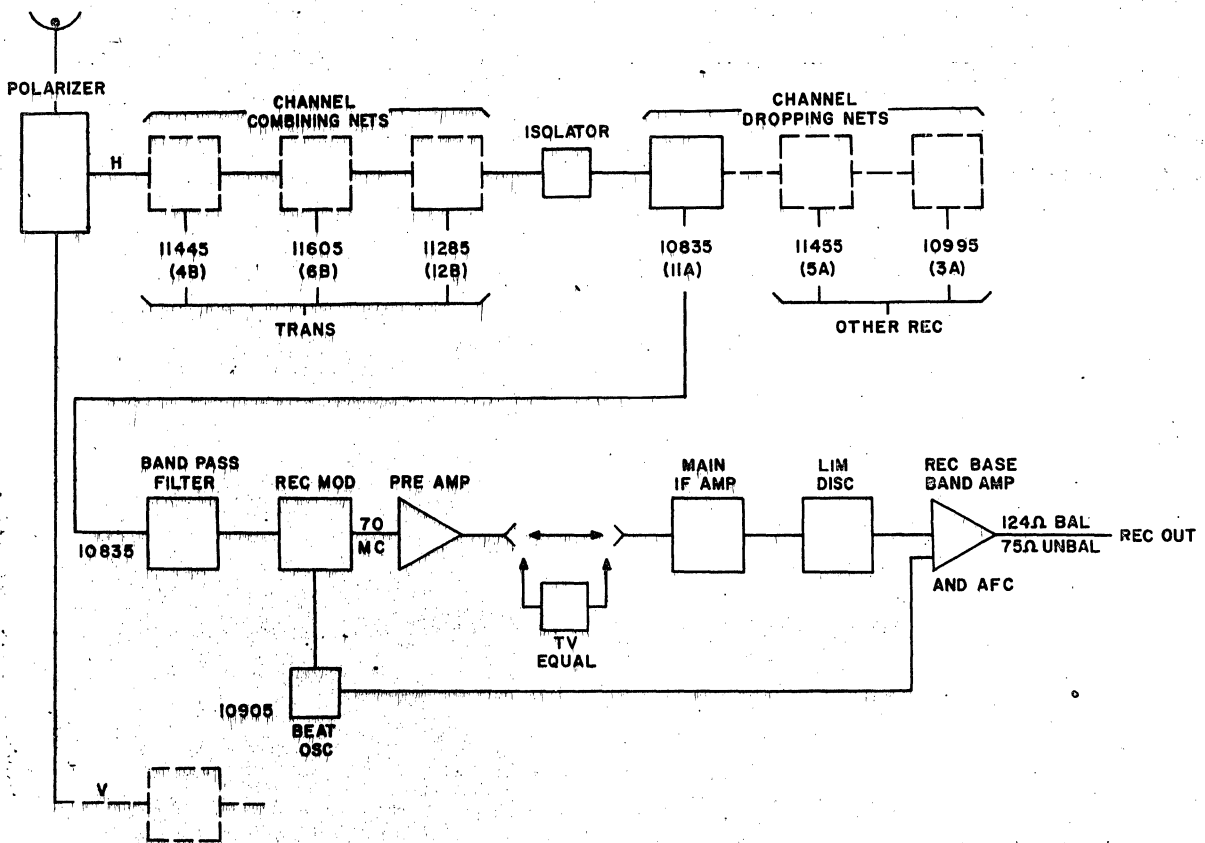

Fig. 20-4 - Receiver Block Diagram

CHAPTER 20 TJ RADIO SYSTEM

polarization separation network which separates the horizontally and vertically polarized frequencies. The separately polarized channels are transmitted through rectangular waveguide to the radio transmitter-receiver bays. In a particular bay, the received signal enters a channel separation network which selects the particular signal required for that receiving channel. The desired signal then enters the receiver through a waveguide spacer, a band-pass filter, a 403A tuner, and finally through a second waveguide spacer to the balanced silicon diode modulator. Although the sum of the spacer lengths is held constant to provide a constant over-all length of the waveguide connecting the channel separation network to the receiver modulator, the lengths of the individual spacers are determined by the received frequency. The spacer lengths are selected to minimize the over-all receiver noise figure by insuring that the image frequency developed in the mixer is reflected back into the mixer in the optimum phase.

In the balanced modulator, the incoming signal is combined with the output of the receiver local oscillator, a reflex klystron, and the resulting 70-mc IF signal is amplified in a low-noise IF preamplifier. For message service, the signal from the preamplifier is connected directly to the IF main amplifier by means of coaxial cable; however, for television applications a delay equalizer is required between the preamplifier and the IF main amplifier.

20.8 ALARMS

The D-2 alarm system has been designed for use with TJ radio. This alarm system is basically a single tone 2,600 cycle device using step switching. It is combined with an orderwire circuit and transmitted over the baseband of the initial TJ diversity pair installed on a given system. By means of loop testing it is possible with this device to locate trouble on a TJ route from one central maintenance center on the route.

CHAPTER 21

TL-2 RADIO SYSTEM

21.1 INTRODUCTION

The TL-2 system is designed to meet the expanding requirements for an economical short-haul light route microwave system. The system provides broadband radio channels in the 11,000 megacycle common carrier range for telephone, data, facsimile, teletypewriter and other services. The present system design does not provide for television transmission. Significant savings of power and space, high equipment reliability, and reduction of testing and maintenance time are achieved by the extensive use of solid state devices. The only "electron tube" devices in the TL system are two Klystrons used as microwave oscillators. The system is intended to have application in at least three areas of need; namely, short very light toll or tributary trunk routes, supplementary circuits along somewhat heavier routes and private line telephone service routes.

21.2 TL-2 FREQUENCY PLAN

The system operates on any of 24 channel assignments standardized in the common carrier band between 10,700 and 11,700 megacycles as shown in figure 21-1. Fully loaded, the TL system is capable of handling six two-way broadband microwave channels when used as a non-diversity system, or three channels with one-for-one frequency diversity. Although the system design provides for short-haul service over distances in the order of 20 to 75 miles, the maximum system length in dry regions topographically suited for optimum microwave transmission may approximate 200 miles. TL transmission in the 11,000 megacycle band eliminates the problem of interference with long-haul systems like TH and TD-2 in lower common carrier bands. Transmission in this band also allows TL microwave to be integrated with existing TJ routes where expansion or diversification of TJ routes is desired. In addition, order wire and alarm systems or light route spurs for existing or new microwave systems in lower bands can be provided in many cases by using 11,000 MC. TL microwave equipment,

21.3 CHANNELIZING ARRANGEMENTS

<u>Carrier System</u>	<u>Minimum Circuit Capacity (10 hops)</u>
ON	96
N	48
T	48
L	600

CHAPTER 21 TL-2 RADIO SYSTEM

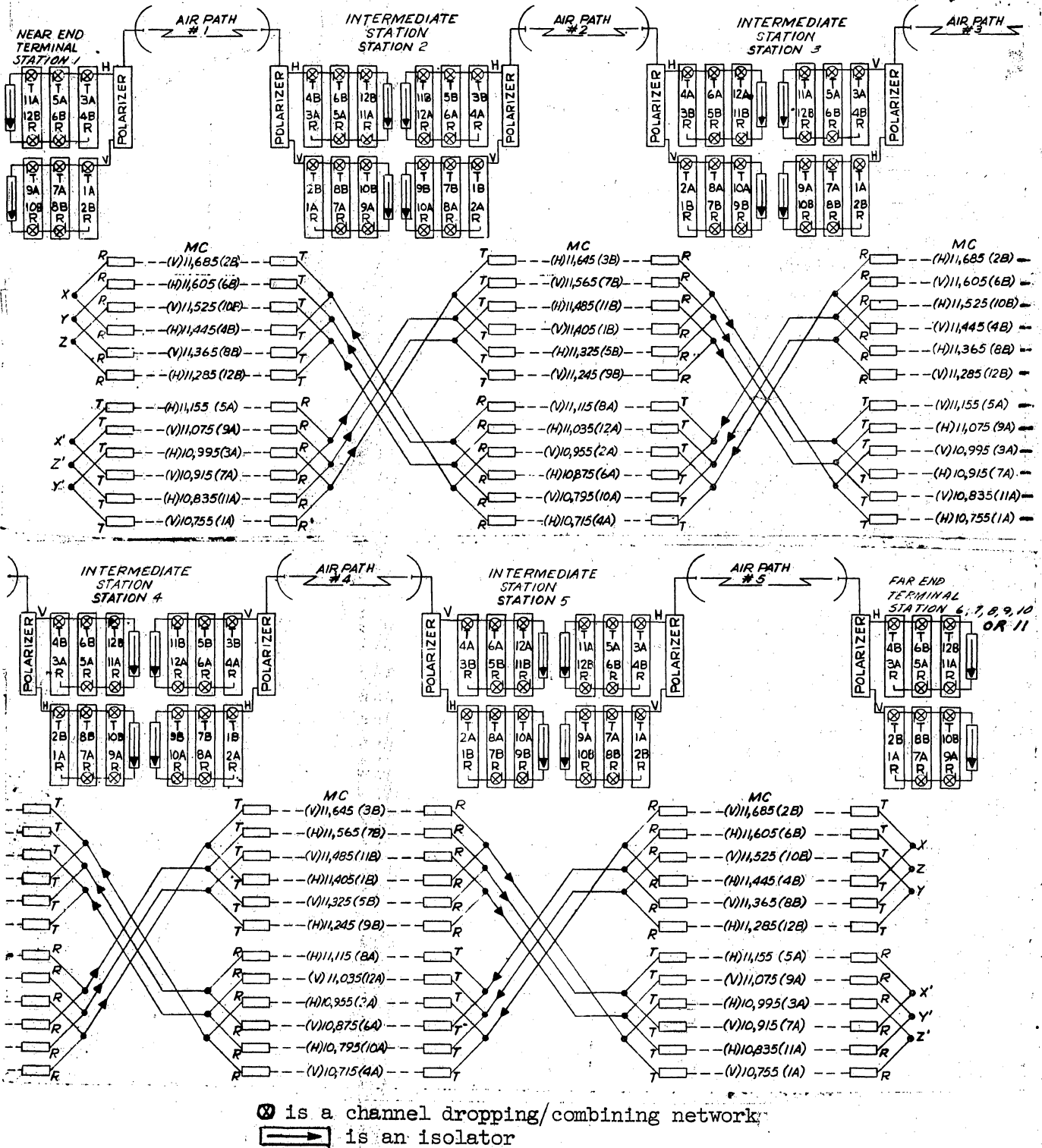

Figure 21-1 T/R Bay Arrangement and Frequency Plan

CHAPTER 21 TL-2 RADIO SYSTEM

Although designed primarily for use as a light-route facility, carrying a relatively small section of message circuits, the TL radio system is extremely flexible and will accommodate many different types of channelizing equipment as shown above. Among these are the present ON, N and L multiplexing arrangements, as well as the new transistorized versions of these systems under development. Also developed for use with TL radio is T-1 Carrier combining equipment. This will permit the use of the solid state pulse code modulation (PCM) multiplex. Since the FM radio frequency signal is reduced to baseband at each repeater and terminal, dropping and inserting of message circuits is simplified.

ON, N, and L Multiplex Equipment

An 8 to 48 channel ON carrier package will be available for use with the TL system. Also available is the existing L-type multiplex equipment using the A-5 channel bank. Both the N and L carrier multiplex equipment which is currently being redesigned to make full use of solid state devices will be arranged for use with TL microwave. In addition, proposed 60, 120 and 240 channel L packaged bays will also be suitable for use.

T-1 Carrier System

The stacking of two 24-channel groups of T-1 carrier will provide 48 message circuits on TL radio. T-1 carrier with its 1.5 MC pulse rate is expected to be attractive for providing a high speed data transmission facility over TL microwave. At present, it is planned to center the second T Carrier group of 24 channels at about 4.5 MC in the TL baseband.

21.4 BASIC BUILDING BLOCK

The basic building block for the TL System will be a cabinet containing a radio transmitter, a radio receiver, alarm and order wire equipment, power conversion equipment, multiplex dropping equipment and storage batteries as shown in figure 21-2. This basic unit would be completely equipped at the factory with the exception of the storage batteries. At the radio site it should only be necessary to mount the housing, install the batteries and connect the antenna, multiplex and AC power. This unit would be a radio terminal. At a repeater there would be two such units, interconnected at baseband to form a terminal type of repeater. Diversity, if applicable, would involve four such units at a repeater or two at a terminal. The equipment is designed for outdoor ambient temperatures of - 40°F. to 120°F.

The transmitter-receiver and associated power conversion unit uses solid state circuitry throughout except for the transmitting and receiving klystrons. Plug-in equipment includes the Receiver Unit and Control Panel. The Receiver Unit (figure 21-3) includes the IF preamplifier, IF main amplifier, limiter discriminator, receiver baseband amplifier, and the receiver AFC

CHAPTER 21 TL-2 RADIO SYSTEM

and AGC amplifiers and squelch circuit. The Control Unit includes meters and control circuitry. The transmitter baseband amplifier is a separate unit mounted inside the Control Unit housing. (figure 21-4)

21.5 KLYSTRONS AND FREQUENCY STABILITY

The TL System will use a nominal power output of 100 milliwatts. This power will provide adequate system performance over path lengths up to the order of 7.5 to 20 miles depending on locality and geographical considerations. The Western Klystron (457A) is used for both the transmitter and receiver local oscillator. The klystron when operated at the 100 milliwatt level will be operating considerably below its full power capability. This results in extended life, increased reliability, and much less battery drain.

A new vapor phase cooling technique is used with the klystrons to obtain the necessary frequency stability. The vapor phase cooler is a closed condensing system consisting of a boiler, a condenser, and an expansion chamber. Heat from the klystron transfers to the boiler, which has intimate contact with the klystron, and boils an inert fluorochemical liquid. Since the liquid boils at nearly a constant temperature the klystron is held at essentially a constant temperature and frequency stability of the klystron is achieved. Use of the vapor phase cooler eliminates the need for transmitter automatic frequency control. Figure 21-5 shows a photo of the transmitter-receiver panel equipment with the klystron cooling arrangement.

21.6 TRANSMITTER-RECEIVER BAY

A transmitter-receiver bay mounting is provided for central office or radio hut applications. (figure 21-6) The equipment is mounted in a single 19" relay rack with space provided in the bottom of the bay for batteries. Any multiplexing equipment required will be mounted in a separate bay.

21.7 DIVERSITY SWITCH

Where service reliability permits, diversity protection will normally not be provided for the TL system. In much of the country, paths are not expected to be of such length as to require protection from selective fading. However, in dry mountainous regions, where natural elevations and light rainfall make the use of longer paths possible, selective fading may make diversity necessary. (figures 21-7 and 21-8) In these situations, fading will be positive at times. Conditions that produce deep fades can also enhance the signal as much as 6 db over its free space value. In addition, equipment protection could be provided by frequency diversity, which might be needed in situations where access for repair is difficult or where complete service protection is essential.

21.5

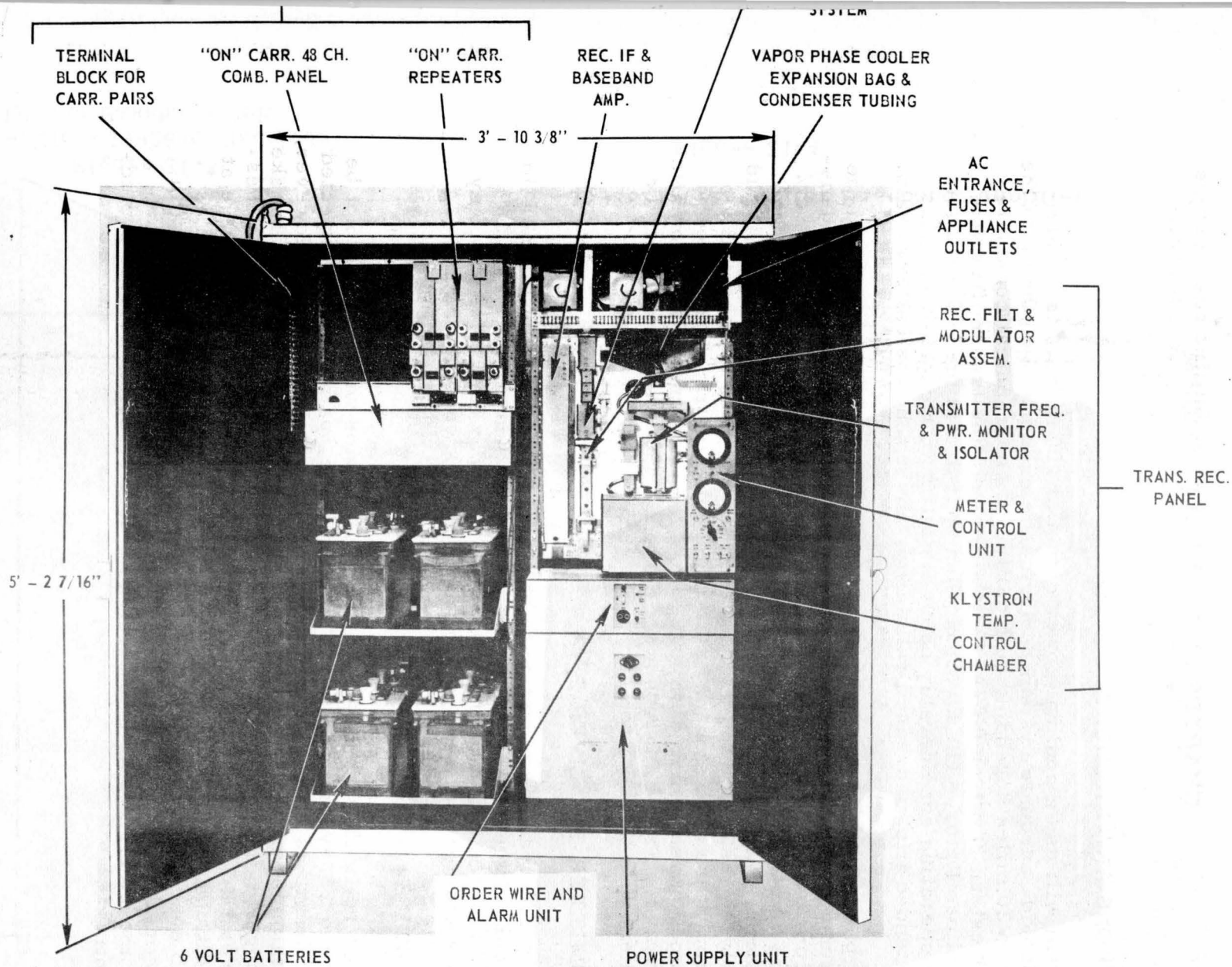

Fig. 21-2 TL Radio Transmitter-Receiver Outdoor Cabinet

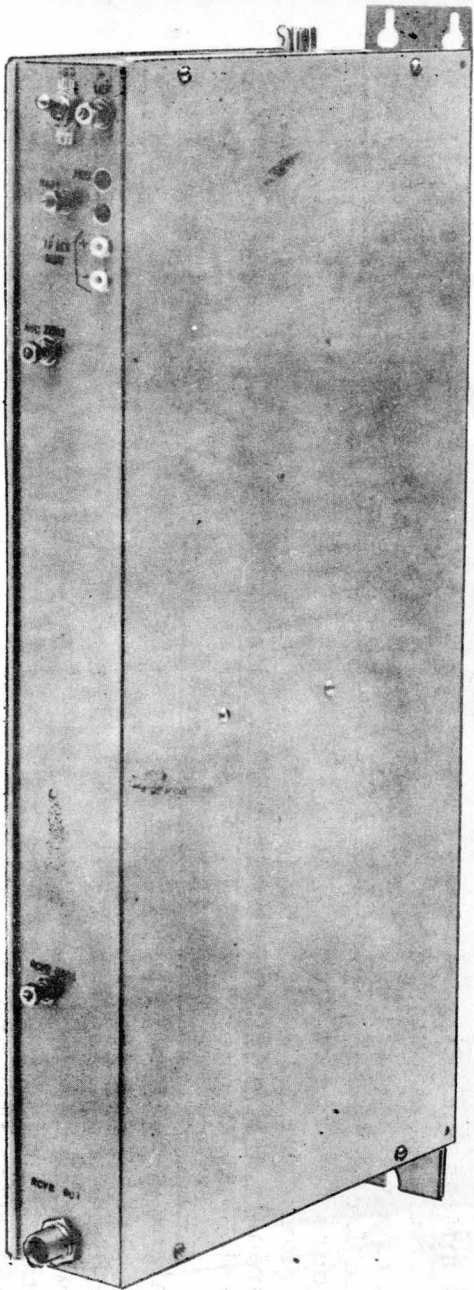
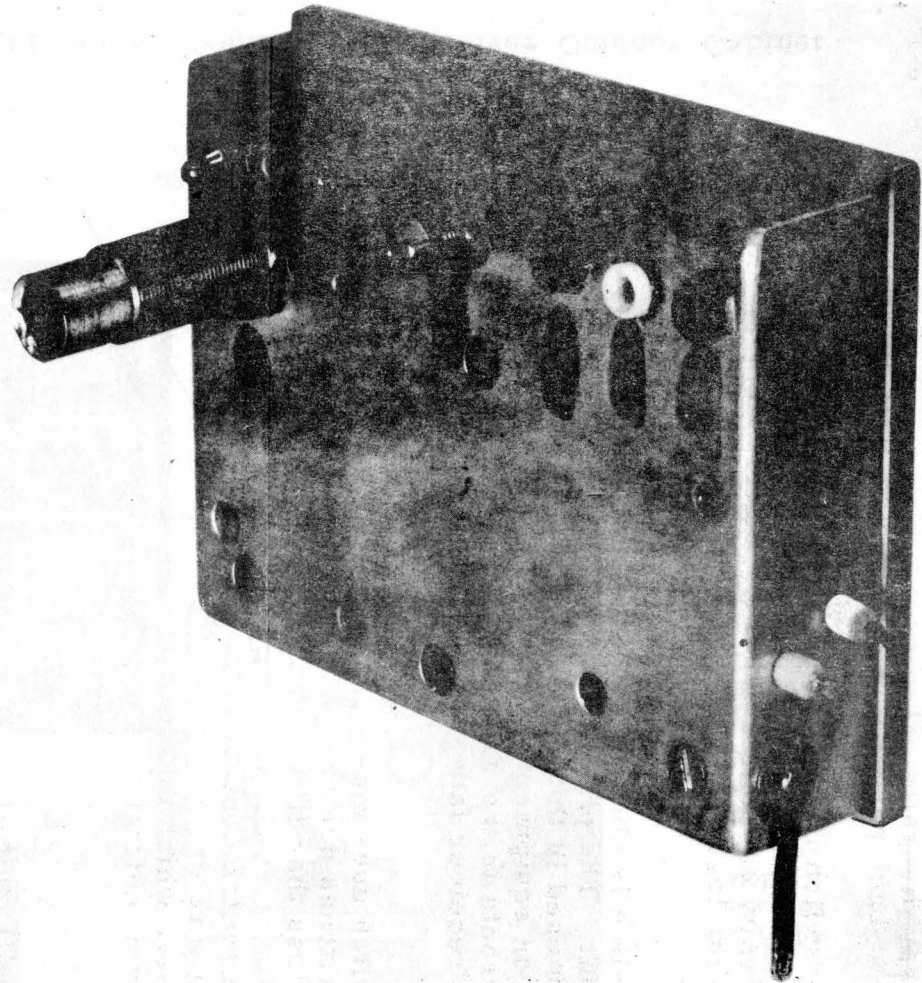

Figure 21-3
TL Radio - J99262G Receiver
IF And Baseband Unit



TL Radio - J99262J Transmitter Baseband Amplifier

Figure 21-4

CHAPTER 21 TL-2 RADIO SYSTEM

Two TL cabinets operated back-to-back make up a two-way non-diversity repeater; a two-way diversity repeater can be provided by installing four cabinets in back-to-back pairs as in figure 21-9.

The TL diversity switch is located within the diversity channel radio cabinet and occupies the space which is normally used for the order wire and alarm panel in non-diversity cabinets. The diversity switch uses solid state circuitry except for the logic and signal switching functions performed by wire spring relays.

Basically, the switch is controlled by 2,600 cps pilot monitors and a fade comparator circuit. The pilot monitors sense the presence of the same 2,600 cps tone as used in the alarm system and provides the logic circuit with information on equipment failures. The comparator circuit monitors vario-losser currents in the receiver IF amplifiers and notifies the logic circuit when one receiver fades relative to the other by a pre-determined amount.

The diversity switch uses make-before-break contacts with hitless switching on fades. Switches due to equipment failures will result in transmission interruptions of less than fifty milliseconds.

In addition to the switch control function, the logic circuit notifies the alarm system when a failure occurs on one of the received pilots. If both pilots fail simultaneously, which might occur when the pilot tone is temporarily removed, no alarm indication is provided.

21.8 POWER

The TL System will operate from storage batteries through transistorized DC to DC converters. The batteries will be continuously charged from commercial 117 volt 60 cycle AC power and upon AC power failure the equipment will continue to operate on battery reserve until the voltages are reduced to some predetermined level. This system has the advantage of providing hitless operating when the commercial power fails and eliminates the need for costly standby power sets. Four 6-volt 100 ampere-hour high specific gravity lead-acid batteries are provided. At 0°F. they will sustain the system for about 18 hours. At temperatures below 0°F. somewhat less than 10 hours reserve can be expected. In emergencies, 6 or 12-volt commercial automobile batteries can be used. In the outdoor cabinet arrangement terminals are provided for connecting a portable engine-alternator during prolonged commercial ac power failures.

In general, it is expected that central office installations of TL radio will utilize TL batteries rather than the regular central office power supply. In offices with 24-volts available the cost of running feeders and of using up office power capacity could easily exceed the battery cost. In 48-volt offices, there would be an additional cost for a dc voltage reducer. Therefore, standard options are not provided to omit TL batteries. If the use of an existing central office battery supply is desired special engineering is required.

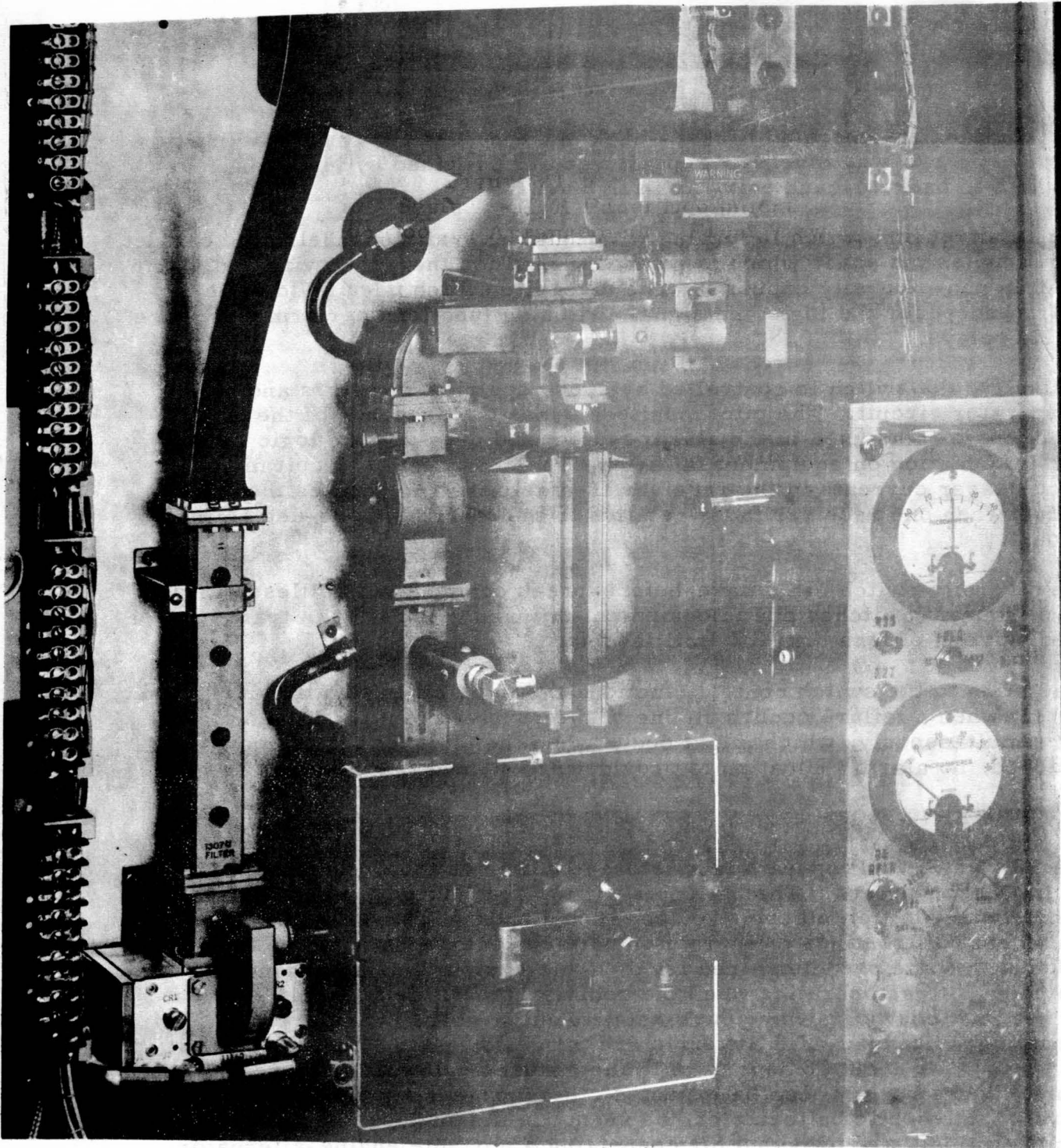

Figure 21-5
TL Radio - System - T/R Panel Equipment
With Klystron Cooling Arrangement - Front View

CHAPTER 21 TL-2 RADIO SYSTEM

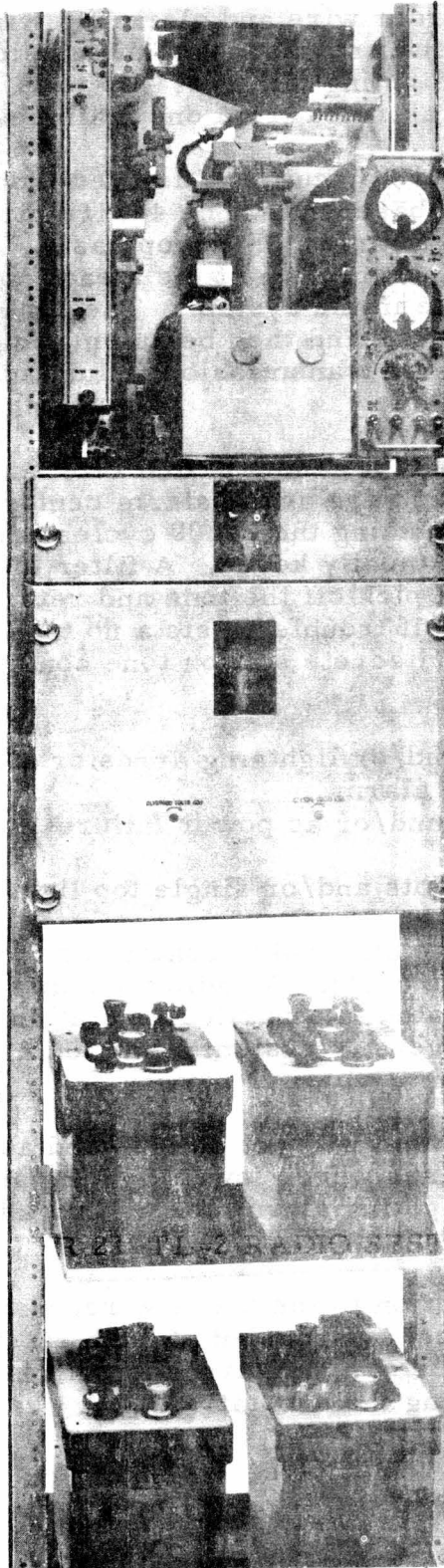

Figure 21-6 Transmitter - Receiver Bay

CHAPTER 21 TL-2 RADIO SYSTEM

21.9 ORDER WIRE AND ALARM SYSTEMS

A simple and inexpensive order wire and alarm system is provided. Basically, the conditions alarmed are channel transmission, ac power, low battery voltage, and tower lighting failures. Up to 11 radio stations in the same radio system may be alarmed from one main station alarm center.

Both the alarm and order wire circuit are derived from the same 4-wire circuit in the low end of the baseband. The 4-wire circuit will carry a 2,600 cycle continuity tone arranged on a loop basis. A detector at the alarm center will indicate interruption of the steady tone to provide an alarm alert telling of trouble in the system. The 2,600 cycle tone will be interrupted for a timed interval and then be automatically restored under all alarm conditions except for transmission failure of a non-diversity system.

After receiving an alarm alert a series of discrete station tones must be manually applied to the order wire at the alarm center for station trouble identification. All tones including the 2,600 cycles are generated from a single oscillator which is manually keyed. A filter tuned to the discrete frequency of the station will pick off the tone and return it to the alarm center if no trouble exists. If trouble exists a no tone or continuous coded tone will be returned. The discrete station tone conditions are:

- a. Full tone - station OK
- b. No tone - radio failure and/or lightning arrestor failure
- c. Code A - battery voltage alarm
- d. Code B - both top lights and/or ac power failure
- e. Code C - flasher failure
- f. Code D - side light or lights and/or single top light failure

The alarm system will locate all trouble conditions to the precise station except for radio equipment trouble. A radio transmission failure of a non-diversity system can be located to a particular station or preceding station in trouble where as for a diversity system a particular station or one of the adjacent stations could be in trouble.

Tower lighting alarm equipment will not be included as part of the basic TL Alarm Panel. For those cases where tower lighting alarms are required a separately mounted tower lighting alarm box will be added to provide additional coding and alerting equipment.

A permanently wired connection to the order wire, with a jack appearance and plug-in telephone head set is provided at each radio station. Operation of a "signaling in" key will create an alarm for calling the main station. No feature is provided for calling the substation.

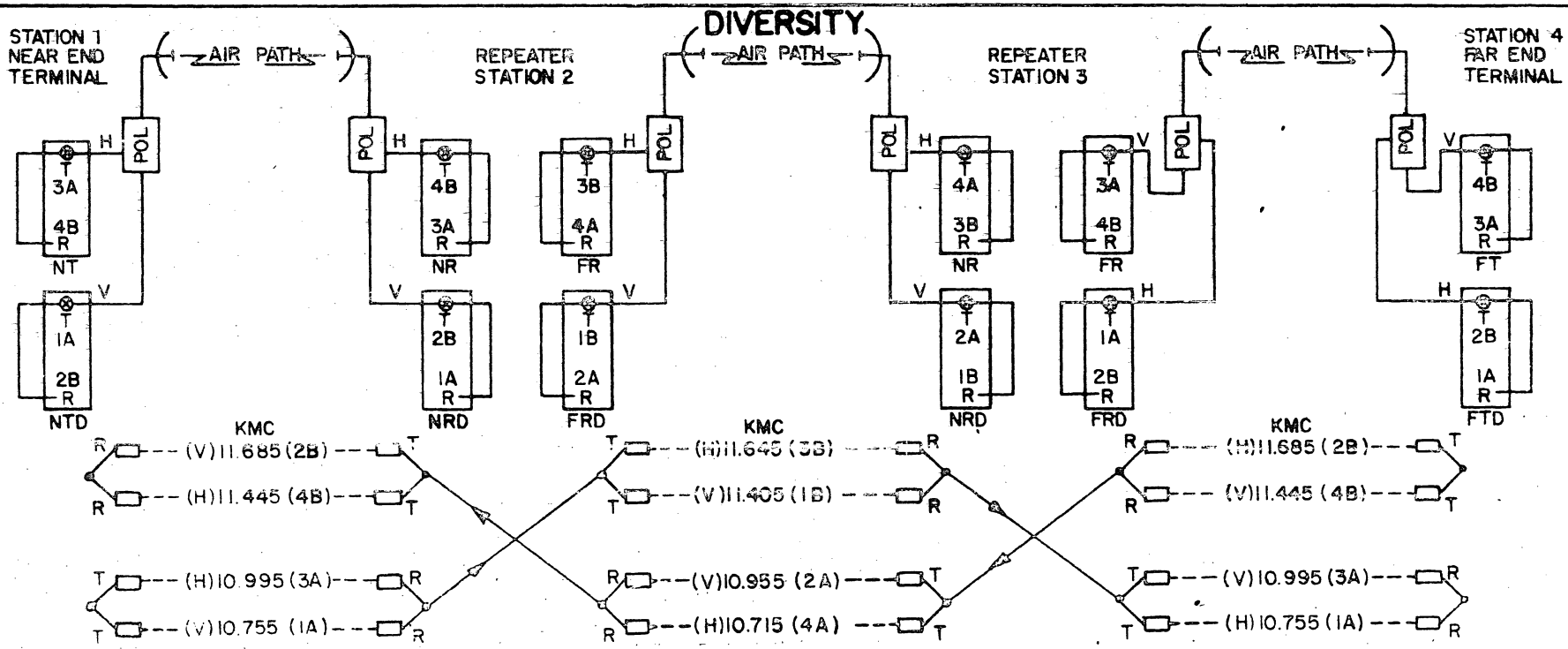
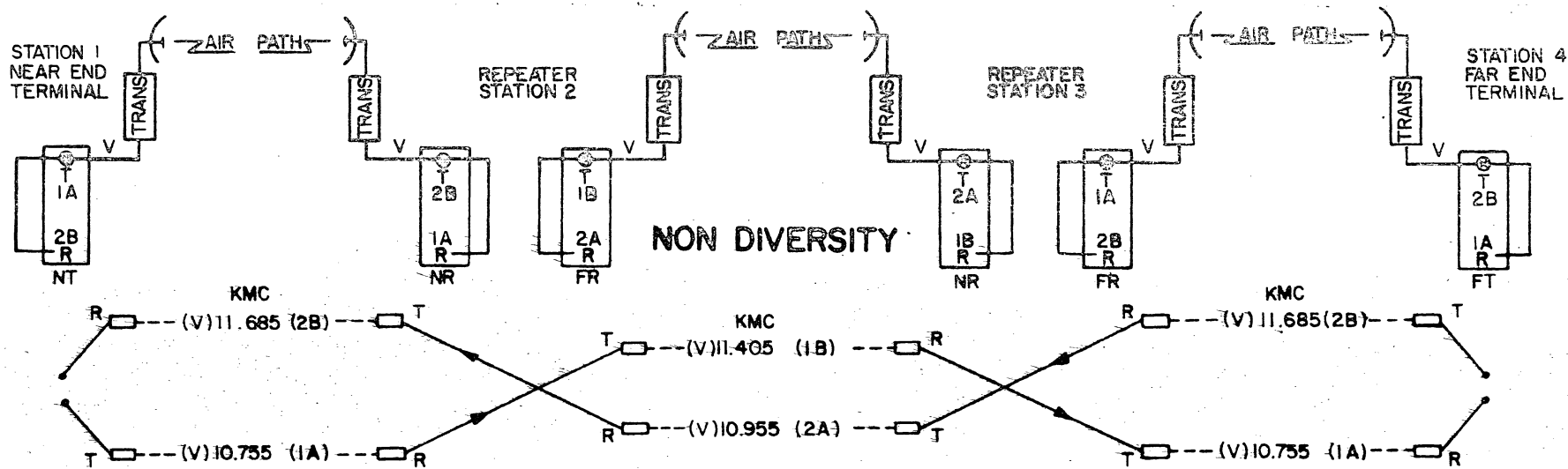

Figure 21-7 TL Radio System

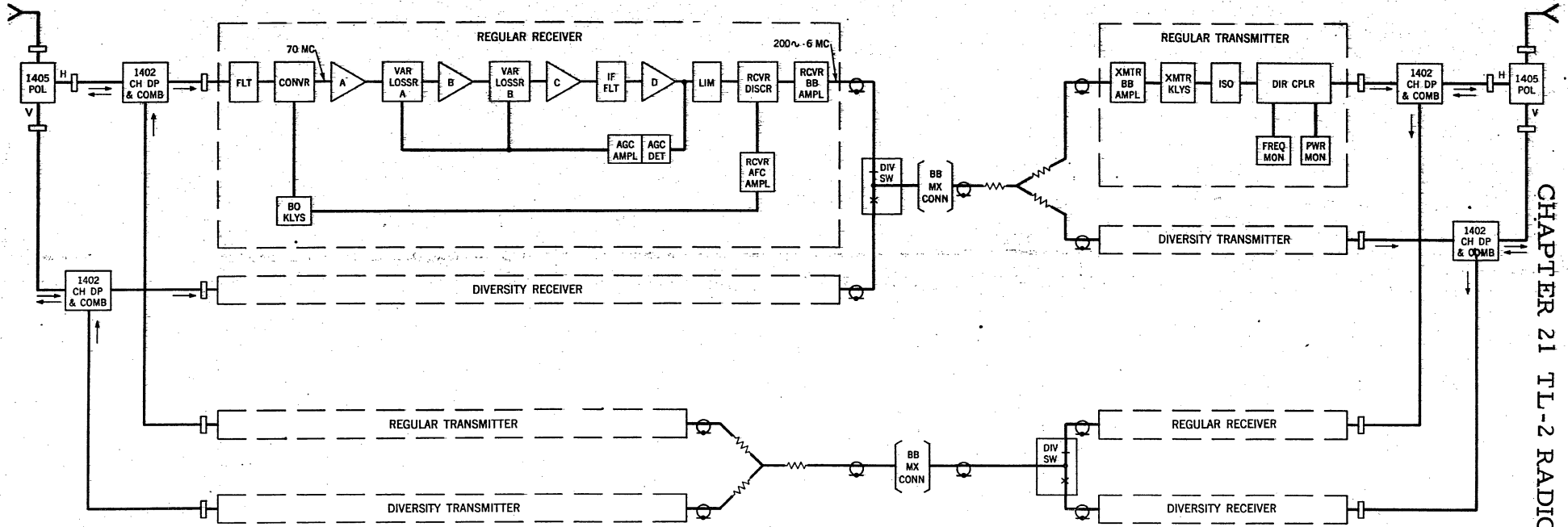

Figure 21-8 Typical TL Radio Diversity Repeater Circuit

CHAPTER 21 TL-2 RADIO SYSTEM

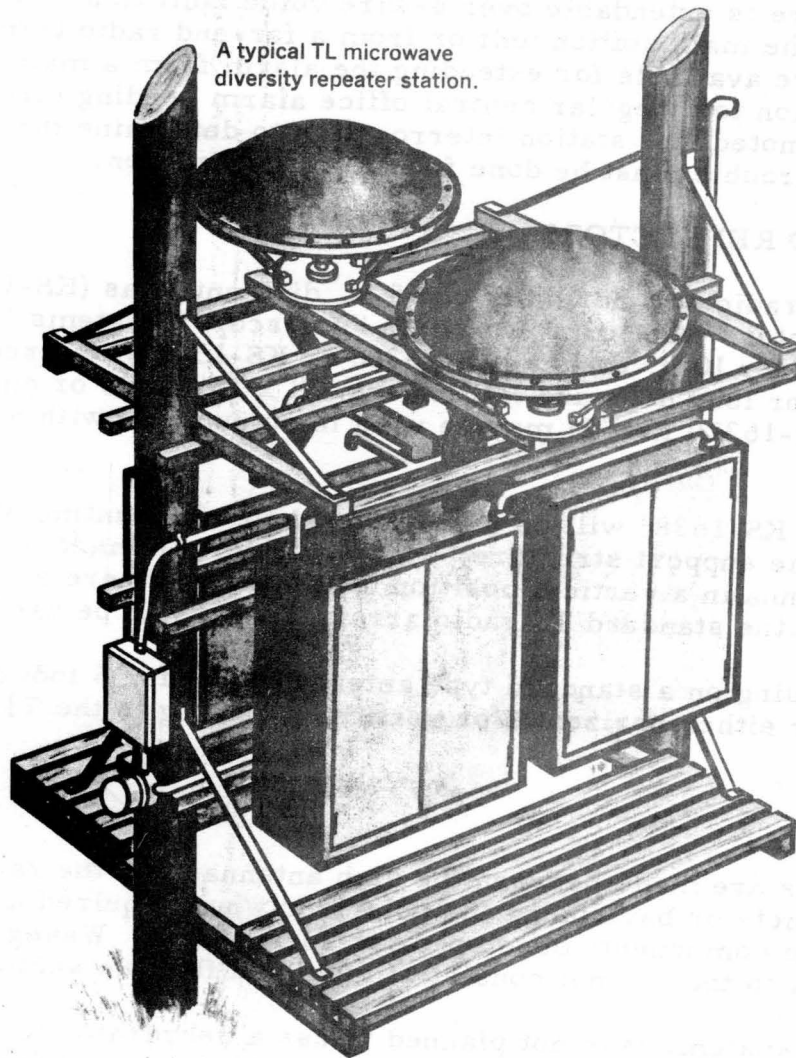

Figure 21-9 Four Cabinets back-to-back

CHAPTER 21 TL-2 RADIO SYSTEM

The order wire and alarm main station unit can be located anywhere provided 4-wire voice facilities are used back to the near-end radio terminal station. The order wire is extendable over 4-wire voice facilities to a remote location from the main station unit or from a far-end radio terminal. Also, arrangements are available for extending the alarm from a main station unit by connection to a regular central office alarm sending circuit. However, it should be noted that station interrogation to determine the location and nature of the trouble must be done from the main station.

21.10 ANTENNAS AND REFLECTORS

It is expected that TL radio will normally use 5 ft. dish antennas (KS-16386) and 6' x 8' plane reflectors (KS-16320 List 1) in "periscope" systems (figure 21-10) and 5 ft. or 10 ft. dishes (KS-16386 or KS-15852) in direct radiating systems. For long hops and tall towers, 8' x 12' plane or curved passive reflectors (KS-16320 List 2) may be used in conjunction with 5' dishes.

Initially, the standard KS-16386 will be used for horizontal mounting of a 5 foot dish on an H-frame support structure. Hardware will be made available for mounting this antenna in a vertical position on a tower. Where roof mounting is required, the standard TJ radio arrangements will be used.

Development is preceding on a standard type antenna mount for 5 foot dishes, which may be used for either horizontal or vertical mounting in the TL system.

21.11 WAVEGUIDE

Waveguide connections are made between the dish antennas and the radio equipment in the cabinets or bays using the polarizer when required and rectangular waveguide components developed for TJ systems. Waveguide runs from the antenna to the cabinet consist of rigid and flexible sections.

Generally, in the TL system, it is not planned to use a dehydrator for pressurizing the waveguide with dry air to prevent condensation of moisture. However, to care for vertical runs of waveguide on towers, standard arrangements will be provided for an opening at the bottom of the waveguide run to permit drainage of any condensation.

21.12 TOWERS

Three types of antenna supporting structures have been developed specifically for TL Radio as follows:

	<u>Heights (ft.)</u>
1. Steel - Guyed Tower	75, 90, and 105

CHAPTER 21 TL-2 RADIO SYSTEM

CHAPTER 21 TL-2 RADIO SYSTEM

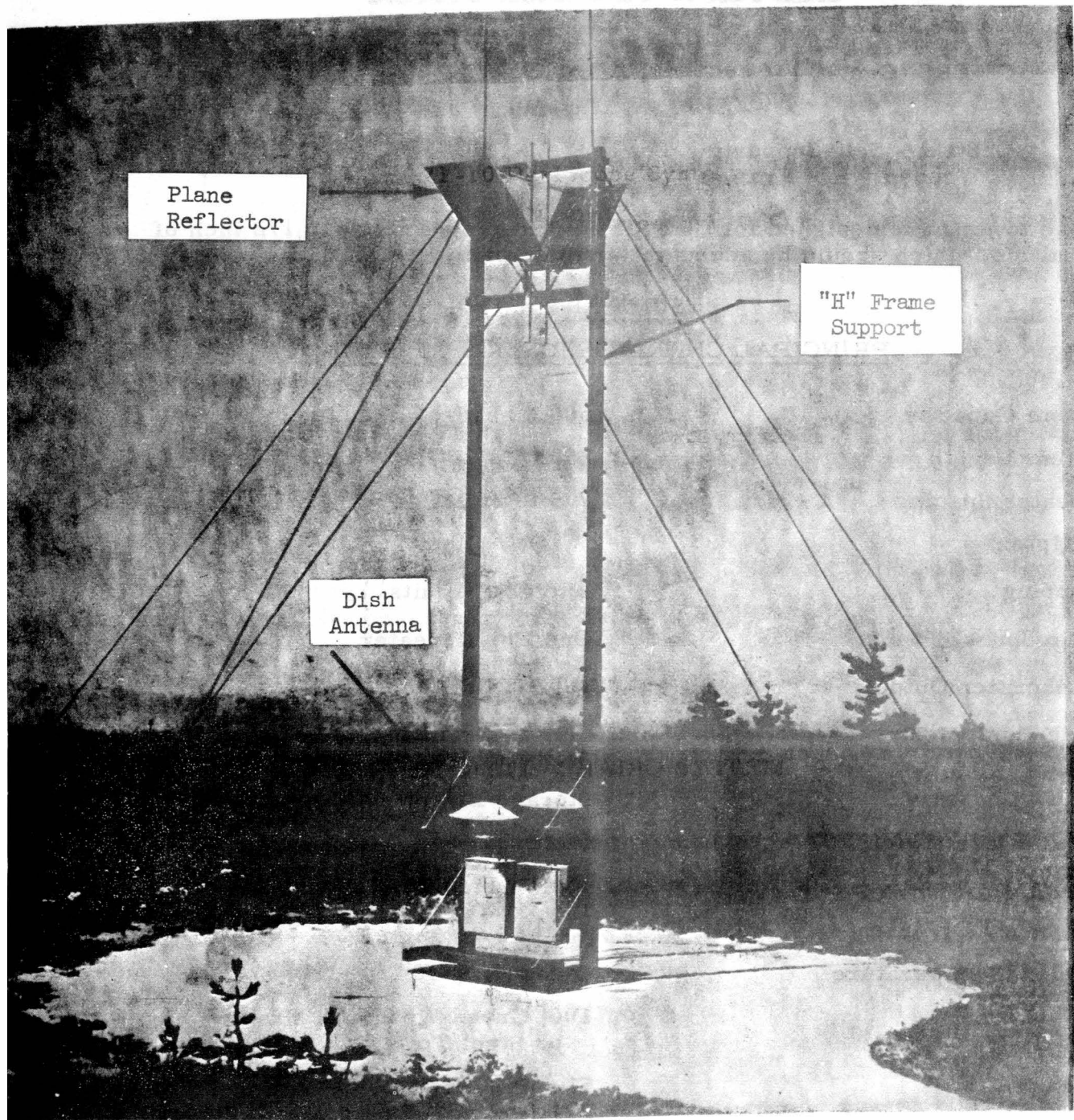

Figure 21-10 Periscope System

CHAPTER 21 TL-2 RADIO SYSTEM

21.12 TOWERS (Cont'd.)

	<u>Heights (ft.)</u>
2. Steel - Self-Supporting Tower	30, 45, 60, 75, 90 & 105
3. Wooden - H - Frame	Up to 60

These towers are designed for 30 PSF wind loading, including 1/2 inch of radial ice, which should be adequate for the typical areas of TL application.

SUMMARY

PRINCIPAL CHARACTERISTICS OF TL-2

System Capacity	600 Message Circuits
System Length	250 Mi./10 Hops (Short-haul)
Repeater Spacing	7.5 to 20 Miles
Multiplex	T, ON, Other
Dropping	2 to 48 Circuits
Radio Spurs	One Per Repeater
Transmitter Output	100 Milliwatts
Basic Equipment	Simple Transmitter-Receiver Box
Power: Primary Reserve	117 V. 60 Cycle AC Storage Batteries
Baseband Bandwidth	6 Mc
Frequency Assignment	10.7 - 11.7 kmc
Frequency Diversity	Available
Ambient Temperature	Outdoors (-40° to +120°F)
Towers	100' Guyed Wooden H Frame or Steel Tower
Antenna	5' and 10' parabolas + 6' x 8' and 8' x 12' reflectors
Alarms	Simple Loop System
Order Wire	Built-in
Housing	Outdoor Cabinet

CHAPTER 22

TM-1 RADIO SYSTEM

22.1 GENERAL

In common with TL-2, TM-1 will feature compact design, high reliability, battery operation, simplified maintenance, low cost, and will be completely transistorized except for the transmitter and receiver klystrons. The basic TM-1 radio equipment units will be applicable to either message or television transmission.

Since the 6 gc frequency band offers freedom from rain propagation outage experienced on 11 gc systems, common carriers have made extensive use of 6 gc frequencies for short haul and long haul systems. However, there has been mounting concern that the widespread usage of 6 gc frequencies will exhaust the 6 gc band prematurely. Application of 6 gc frequencies on one-for-one frequency diversity systems is of particular concern, and considerable attention has been focussed on alternatives which would better conserve 6 gc frequencies.

Crossband diversity utilizing one 6 gc channel in diversity with an 11 gc channel minimizes usage of 6 gc frequencies at substantially no sacrifice in reliability or economy over 6 gc diversity operation. TM-1, therefore, is designed to be applied in crossband diversity with a channel of 11 gc TJ, TL, or TL-2 and has been presented to the FCC Staff on the basis of crossband diversity application. TM-1 in combination with TJ, TL, or TL-2 is being designed to meet a 10 hop yearly outage objective of .02% for all causes in any area of the country when applied on the basis of the TM-1 hop capability.

22.2 TRANSMISSION

The TM-1 design capacity is shown in Table A. These figures assume hop lengths which will yield a minimum received signal of -45 dbm and 35 dbrn (C weighting) at the OTLP (29 dbaO) maximum noise in the worst message circuit. The -45 input signal includes a 3 db maintenance margin to allow for minor imperfections in system lineup, degradation of the system with time and such matters. It will be noted that TM-1 is being designed to meet an objective of 35 dbrnO which represents a 2 db reduction in allowable noise over the previous objective of 37 dbrnO. The capacities indicated in Table A are design objectives subject to verification on working equipment. For network television service, color standards and spur route operation are assumed. In the case of monochrome ETV service, it is expected that the maximum allowable number of hops will exceed 10; however, tests on working equipment are required to determine a more final figure.

CHAPTER 22 TM-1 RADIO SYSTEM

Table A

TM-1 Radio Channel Design Capacity

<u>Type of Load</u>	<u>Message Circuits</u>	<u>Number of Hops</u>
L Carrier	600	10
ON "	96	10
N "	48	10
Network TV	*	6
ETV	*	10

* 1 TV channel per radio channel.

Table B shows the principal transmission characteristics of TM-1 and TL-2 as designed for application in a crossband diversity system.

Table B

TM-1 and TL-2 Characteristics

	<u>TL-2</u>	<u>TM-1</u>
RF Frequency Range	10.7 gc - 11.7 gc	5.925 gc - 6.425 gc
Frequency Plan	TJ Plan	Split Channel TH (see Figure 1)
Number of Available RF Channels	24	32
Transmitter Power (Minimum)	+20 dbm	+20 dbm
Transmitter Frequency Stability	±0.05%	±0.02%
Rated Peak Deviation	±5 mc	±5 mc
Nominal Receiver Input	-45 dbm	-45 dbm
Receiver Noise Figure (Receiver Inputs of -45 dbm or lower)	11 db	11 db
Fading Margin	30 db (min.)	30 db (min.)
IF Center Frequency	70 mc	70 mc
IF Bandwidth	20 mc	16 mc
Baseband Width	10 cps - 6 mc	10 cps - 6 mc
Amount of Pre-emphasis (600 channels)	9 db	9 db
Maximum Hops Per Alarm Section	10	10

For television services, both TM-1 and TL-2 will be arranged to accept and deliver a 0 dbv video signal. The video output signal will be unclamped and input and output impedances will be 75 ohms unbalanced.

CHAPTER 22 TM-1 RADIO SYSTEM

22.3 FREQUENCY PLAN

Figure 22-1 shows the TM-1 frequency plan together with the TH frequency plan. Since TM-1 can carry 600 voice channels, as contrasted to 1860 voice channels for TH, less RF bandwidth is required for TM-1 than for TH. It will be noted in Figure 1 that the TM-1 frequency plan places 2 RF channels in each TH channel assignment. The TM-1 carriers are spaced approximately 15 megacycles apart, and are displaced about 7.5 megacycles from each TH broadband carrier. A total of 32 RF channels are therefore provided in the TM-1 frequency plan which is referred to as the Split Channel TH Frequency Plan.

The Split Channel TH Plan as applied at a repeater is shown in Figure 22-1. It will be noted that this is a high-low frequency plan. At the station shown, all transmitters are assigned to the 16 high channel frequencies, and the receivers are assigned to the 16 low channel frequencies. At the next repeater, all transmitters would be assigned to the 16 low channel frequencies and the receivers would be assigned to the 16 high channel frequencies. Figure 1 also shows that adjacent channel frequencies are assigned to opposite directions of transmission. Each direction of transmission is further subdivided into horizontal and vertical polarization. In a given direction of transmission the Split Channel TH Plan, as applied to TM-1, provides for a total of 8 two-way channels; 4 polarized vertically and 4 polarized horizontally.

22.4 DIVERSITY TECHNIQUES

It is planned to make the following three diversity techniques available for application of TM-1 with 11 gc systems.

1. Revertive Switch - where the switch prefers closure on one diversity channel over the other channel. Switch transfer and closure on the non-preferred channel takes place only during periods of non-correlated failure or deep fading on the preferred channel and reverts to the preferred channel when the trouble on it disappears. Revertive switching is desirable on hops where there is a significant difference in the noise performance of the diversity channels.
2. Linear Combiner - where both channels of the diversity pair are combined to give one output. When the two channels which are to be combined yield exactly the same noise performance, a noise improvement of 3 db will result. If the noise performance of the two channels differ by 2 db, an improvement of about 2 db over the better channel will result. There will be no combiner improvement over the better channel if the noise performance of the two channels differ by more than 4.8 db. Any noise improvement through application of combiners on a system could be translated into increased capacity;

CHAPTER 22 TM-1 RADIO SYSTEM

however, at this early stage in development, it is recommended that combiner advantage be omitted from system design estimates since an evaluation of the specific design must be made to determine realizable gains under various operating conditions. The linear combiner is expected to be applicable on TM-1/TL-2 systems where noise performance versus received signal power for a given load is expected to be practically the same. Present plans are to provide linear combiner arrangements only for TM-1/TL-2 application.

3. Bistable Switch - where the switch closes on one channel of the diversity pair until that channel fails, or fades a predetermined amount relative to the other channel, whereupon the switch transfers and closes on the better channel. This is the present diversity technique employed on TJ, TL and TL-2 and it is expected to have limited application when these systems are used with TM.

22.5 ANTENNAS

There will be two antenna types initially available for 6/11 gc crossband operation; the horn reflector and a dual-frequency antenna manufactured by the Gabriel Company.

The horn reflector will accommodate dual polarization at both the 6 gc and 11 gc frequencies and, therefore, can accommodate 8 two-way channels of 6 gc TM-1 plus 6 two-way 11 gc channels or up to 6 two-way crossband diversity channels plus 2 two-way 6 gc channels.

The Gabriel dual-frequency antenna, shown in Figure 22-2, provides for dual polarization in the 11 gc band and plane polarization in the 6 gc band on 3 separate rectangular waveguide feed lines. Although the Gabriel antenna is offered in sizes from 4 to 16 feet in diameter, it is planned to provide standard mounting arrangements and KS specifications for the 6 and 10 foot sizes only. This antenna design will accommodate up to 4 two-way channels of 6 gc TM-1 plus 6 two-way 11 gc channels or up to 4 two-way crossband diversity channels plus 2 two-way 11 gc channels.

CHAPTER 22 TM-1 RADIO SYSTEM

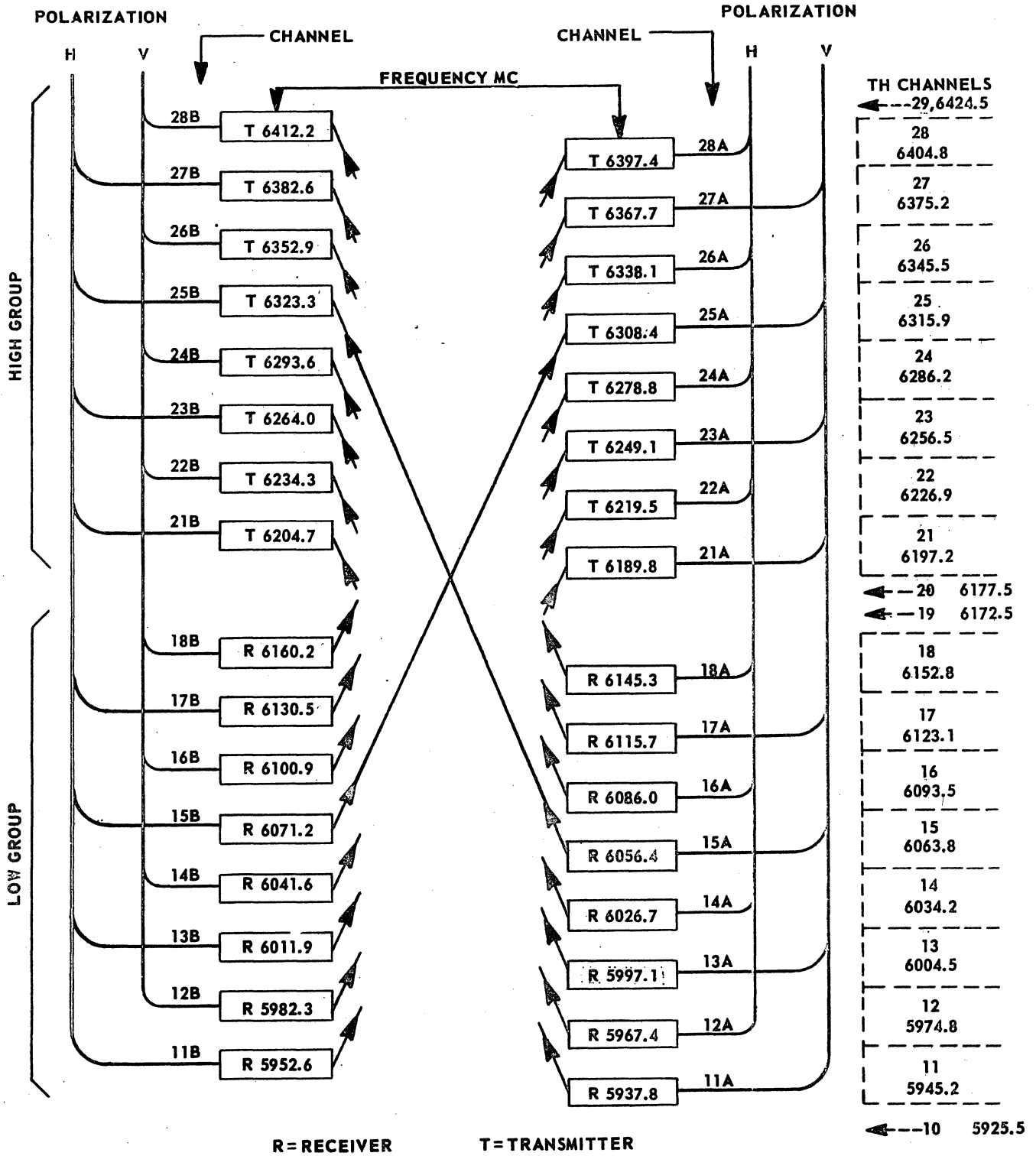

Fig. 22-1 TM Frequency Plan (Showing High-Group - Transmitting Repeater)

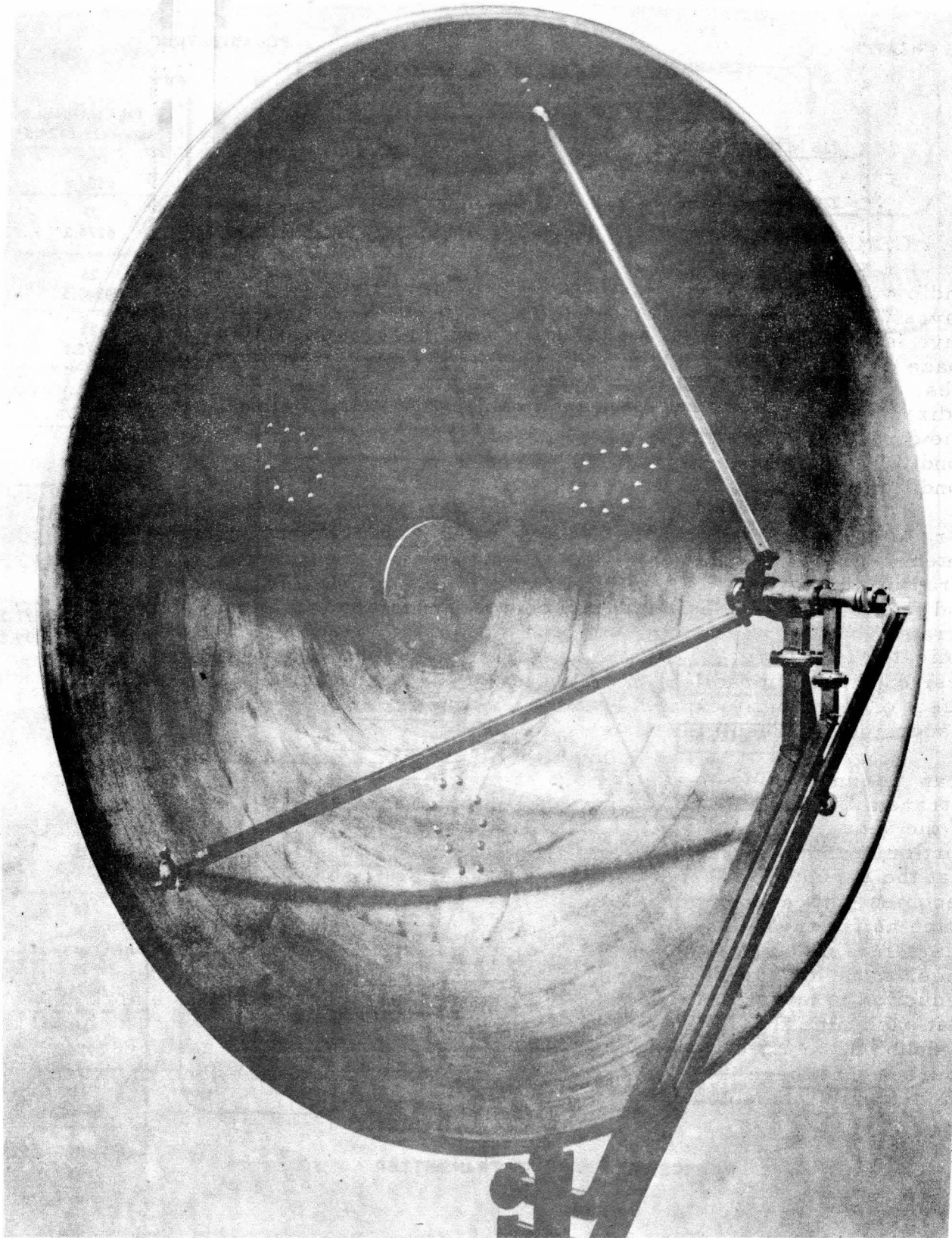

Fig. 22-2 Gabriel Dual Frequency Antenna

CHAPTER 23

MICROWAVE TRANSMISSION CONSIDERATIONS

23.1 GENERAL

Radio wave propagation is by means of sky waves, ground waves or space waves. Since the ground wave has very high attenuation, and since the sky wave is reflected at such an angle that it misses the earth's surface, the space wave is the only useful method of propagation at microwave frequencies. As previously mentioned, the space wave consists of two components, a direct component and a reflected component as indicated in Figure 23-1a. The direct component is subject to bending or refraction by atmospheric conditions as is also the reflected wave, however, as discussed later, these conditions occur at infrequent intervals.

If radio energy is considered to be radiated from a point source or isotropic antenna, the wave front will be in the form of the surface of a sphere having a radius which is expanding at the speed of light. A reflector or reflector and lens system would concentrate the radiation into a narrow cone or pyramid but the wave front would still be spherical. These conditions are indicated in Figures 23-1b and 23-1c. Although a plane wave front is desired, it is impractical to obtain with present radiating systems. This effect of the rapidly expanding sphere or section of a sphere is known as dispersion and results in dispersion losses.

If an antenna having an area of one square foot is placed at a distance from a transmitting antenna such that it will correspond to 1/100 of the surface of the spherical wave front at that distance, it is apparent that only a small portion of the total radiated energy will be intercepted. Bearing in mind that the surface of a sphere is proportional to the square of the radius, it becomes evident that when the one square foot receiving antenna is moved twice as far from the transmitting antenna, it will then cover only one-quarter as much of the area of the spherical wave front and will therefore receive one-quarter as much power as it did originally. A four to one reduction in power corresponds to a loss of 6 db. It thus becomes apparent that each time the distance between the transmitting and receiving antennas is doubled the effective loss is increased by only 6 db. This assumes, of course, that there is no change in antenna configuration at either end when the distance is doubled.

CHAPTER 23 MICROWAVE TRANSMISSION CONSIDERATIONS

23.2 LINE OF SIGHT CONSIDERATIONS

It was pointed out earlier that microwave propagation follows optical principles and that if an electrically opaque object is placed in the path, a shadow results which would increase the path loss. It was also pointed out that the shadow could be produced by intervening objects such as buildings, a water tower or the surface of the earth due to the earth's curvature. To provide the minimum path loss between two antennas, it is therefore apparent that there must be the equivalent of an optical line of sight between the two antennas. It has been determined that at 4 kmc a receiving antenna located behind a steep hill 500 feet high and ten miles distant from a transmitter would experience a loss of approximately 30 db as compared to a receiving antenna located at the top of the hill with a clear line of sight. It is also possible to experience a loss from an intervening object which produces a knife edge effect such as the edge of a sharp cliff. If the radio beam just grazes an edge of this type, diffraction or bending of the beam occurs just as in the case of light. This type of obstruction in the line of sight path may introduce losses of as much as 20 db or more.

23.3 CLEARANCE

In addition to clear optical line-of-sight, there must be further height of the beam above intervening obstacles to obtain minimum loss between the transmitting and receiving antennas. By referring to Figure 23-1a it will be seen that the receiving antenna is energized by radio waves arriving from two different directions; one the direct path, and another the reflected path. If the reflecting surface is near the line-of-sight, the reflected wave will have traveled over a longer path than the direct wave and will have been shifted by 180° in phase at the reflection point. Consequently, the direct and reflected waves will not combine in phase and the useful energy at the receiving antenna will have been reduced due to cancellation.

As the line-of-sight is raised above, or away from, the interfering object or the point of reflection, a condition will be reached where the reflected path will be one-half wave length longer than the direct path. Under this condition, the reflected energy will add to the direct energy in phase, resulting in a gain of about 6 db over the energy that would be received over the direct path alone. This condition is known as the first Fresnel zone of clearance. At the second Fresnel zone of clearance the reflected path will be a full wave length longer than the direct path and cancellation results. With third zone clearance, addition once more results. This again is a situation which follows optical laws.

The loss in the clearance range up to the first Fresnel zone can reach values as high as 60 db, with loss values in the order of 35 db at the second, fourth, sixth, eighth, etc., Fresnel zones. The gain over the free space loss in the first, third, fifth, seventh, etc., Fresnel zones is the order of 6 db. It therefore becomes apparent that a line-of-sight

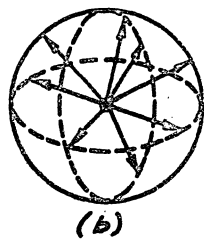
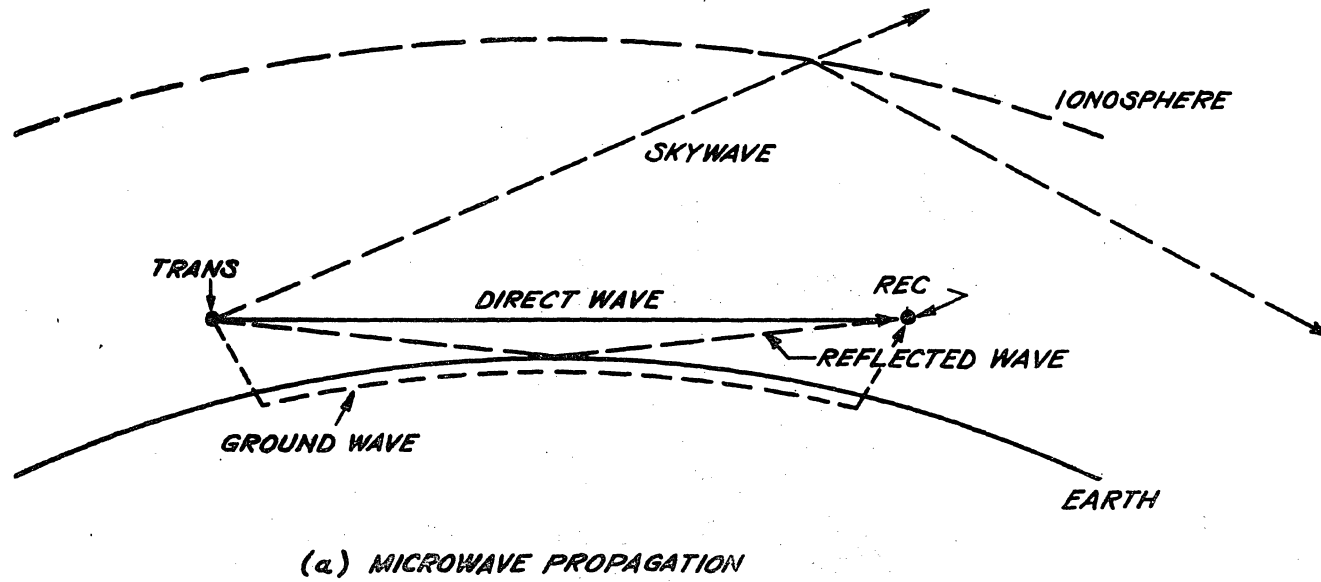

DISPERSION

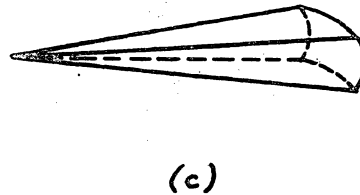

Figure 23-1 Propagation

CHAPTER 23 MICROWAVE TRANSMISSION CONSIDERATIONS

clearance equal to the first Fresnel zone is desirable from an economic standpoint. Clearances in excess of the first Fresnel zone would require impractical antenna heights, whereas clearances substantially less than the first Fresnel zone results in excessive loss. The loss gain pattern is indicated in Figure 23-2a.

An equation may be derived which will indicate first Fresnel zone clearance. The direct path TR shown in Figure 23-2b is one-half wave length shorter than the reflected path TPR. The dotted line is the locus for the point P under which first Fresnel zone clearance exists. The distances D1 and D2 are expressed in miles from the ends of the path to the point under consideration. The equation for the clearance C in Figure 20-2b then is:

$$C = 131.5 \sqrt{\frac{D1 \times D2}{D1 + D2} \lambda}$$

If the wave length λ is in meters, the clearance obtained by this equation will be in feet.

23.4 FADING

If transmission were stable, it would be possible to select antenna heights so as to work on the peak of the characteristic where the widest maximum occurs at first Fresnel zone clearance as shown in Figure 23-2a. Atmospheric refraction or bending of the radio waves will change the effective clearance and will become more serious as the reflection coefficient becomes higher. Some experimental facts have been observed with respect to fading, as follows:

- a. Fading is greater at night than during the day; is greater in warm and humid seasons than in cool and dry seasons; is greater over water or smooth terrain than over rough ground; and is different in different parts of the country.
- b. Ground reflections are usually negligible in rough country; in smooth terrain with numerous trees; and in urban areas with numerous buildings of varying heights.
- c. On paths having strong ground reflections fading can be minimized by using one high and one low antenna. This could be accomplished either with a mountain to valley path or from a high tower to a very low tower. As a result of the above facts, empirical relationships have been worked out which can be applied to modify the clearance factor obtained in the above expression for paths that are predominantly over water or smooth barren country; or for paths that include

CHAPTER 23 MICROWAVE TRANSMISSION CONSIDERATIONS

irregular or wooded terrain; or urban areas with numerous buildings of varying height, and also for regions where dense ground fogs are common. These relationships are based upon experience and must be applied with engineering background and engineering judgment. The actual modifying factors can be obtained from texts which are devoted to the engineering of microwave paths.

23.5 DUCTING

At times, in the spectrum region above 30 megacycles, transmission beyond the horizon has taken place as the result of a phenomenon known as ducts. Ducts appear to be a sort of atmospheric waveguide which may be caused by moisture content and temperature variations that result in energy being conducted along the surface of the earth beyond the horizon. They provide a channel of high level energy beyond the earth's shadow area. This phenomenon has been used in several instances over moderate water path distances to provide temporary circuits during times when the elevation obtainable was not sufficient to overcome the effect of water reflections. The microwave antennas in these instances were found to function best at elevations of only a few feet above the surface of the water. It is not anticipated that this phenomenon would be utilized for normal transmission paths.

23.6 OVER THE HORIZON TRANSMISSION

It has long been known that ultra-high frequencies travel over the horizon under certain conditions, but they were thought to be too weak and undependable for practical use. In the course of investigating occasional interference attributed to these waves, however, both the Bell Telephone Laboratories and the Massachusetts Institute of Technology discovered that many actually overshoot the relay towers they were aimed at and arrived at points farther along the radio path with remarkable consistency.

By erecting larger antennas such as shown in Figure 23-3, and by using higher power than is employed in the conventional microwave system, transmission has been accomplished over distances as great as 600 miles without intermediate relay. The effect of this system is very much like that of a powerful searchlight which casts a beam in a straight line. A searchlight aimed at the sky can be seen from the ground miles away, even when the searchlight is behind a hill. This is possible because some of the light is reflected to the ground by the atmosphere.

In order to make use of over the horizon transmission, 100 kilowatt transmitters and 120 foot diameter antennas have been used. This is 20,000 times the power and 30 times the antenna area used in the present continental microwave system. It was found necessary to employ the lower frequencies (in the UHF band) to develop, with available equipment, sufficient power to attain a satisfactory degree of reliability.

23.6

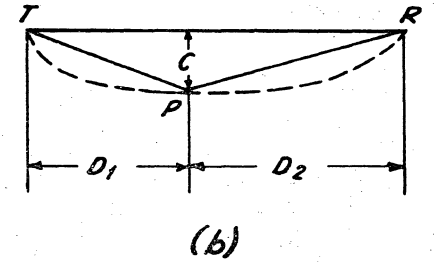
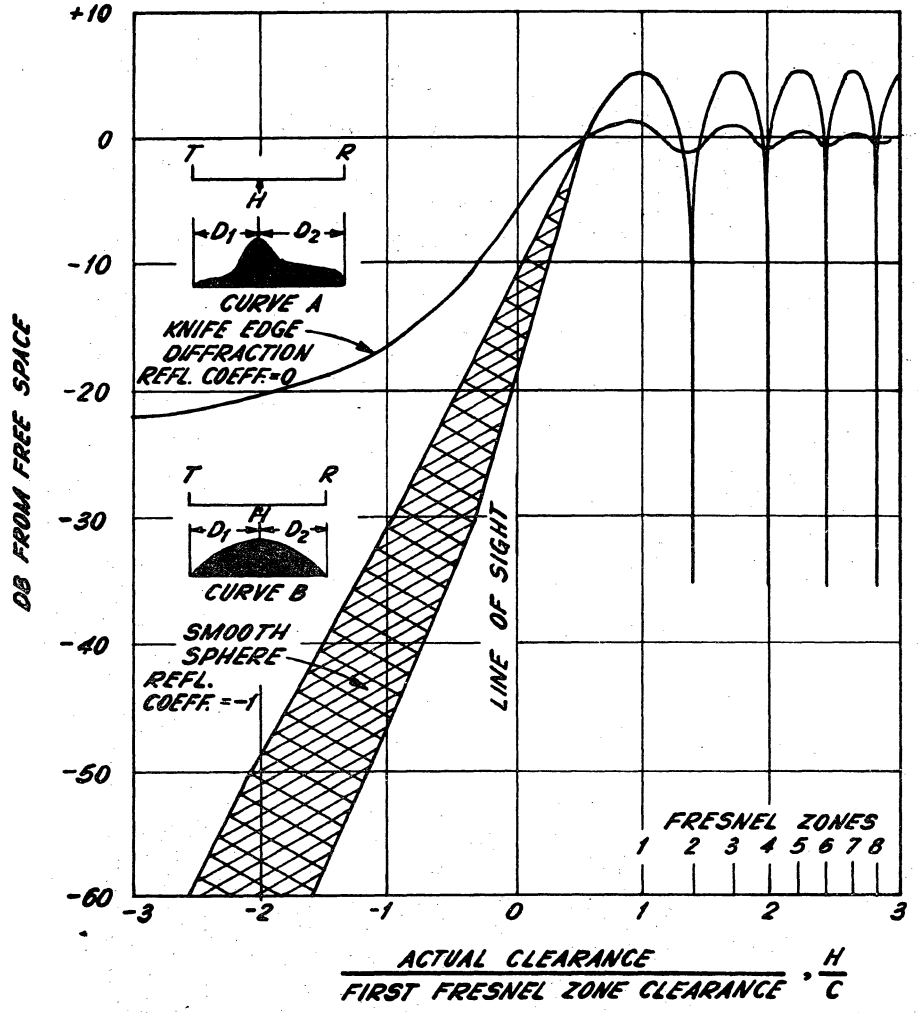

(a)

Figure 23-2 Fresnel Zone Clearance

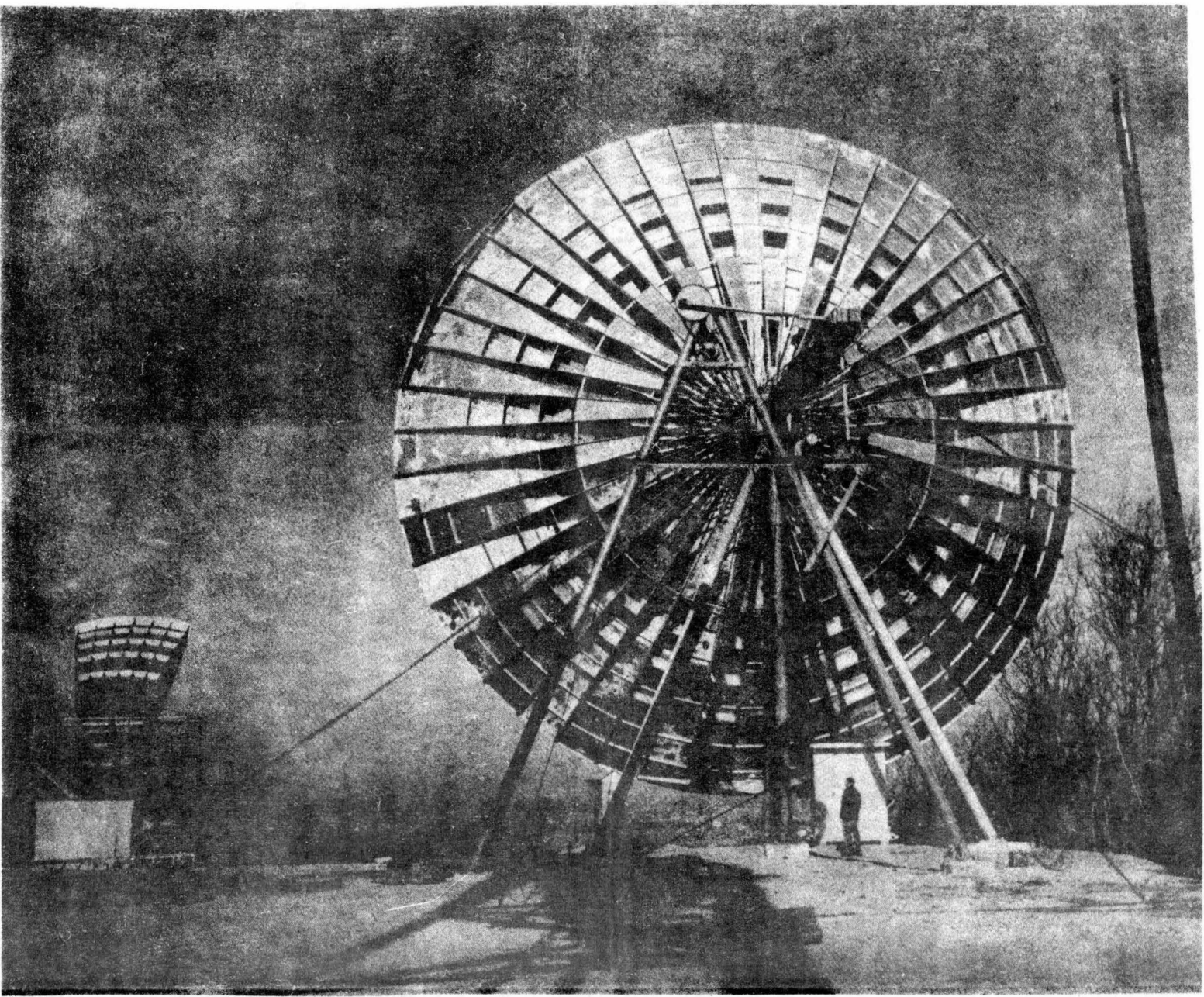

Figure 23-3 Experimental Over-The-Horizon
60' Antenna

CHAPTER 23 MICROWAVE TRANSMISSION CONSIDERATIONS

Over the horizon signals are not to be confused with a similar type of transmission known as "ionospheric scatter" which is useful in long distance transmission of telegraph signals at relatively low frequencies. Unlike ionospheric signals, the over the horizon technique provides signals that are useful for the wide-band widths required for as many as 240 telephone channels.

23.7 NOISE

As shown in Figure 23-4 noise of the static type, either natural or man-made, becomes less objectionable as the frequency is raised and is non-existent above about 1,000 megacycles. In the microwave region the thermal or resistance noise which originates in the front end or low level stages of the receiver is the controlling factor.

The interference to good transmission produced by noise is not so much dependent upon the absolute level of the noise as it is upon the relationship between the signal level and the noise level. Obviously, a given amount of noise would be much more disturbing when superimposed upon a received signal of 1 microvolt than would the same amount of noise when superimposed upon a received signal having a level of 2,000 microvolts. Accordingly, although a noise may be rated in terms of power related to 1 milliwatt, it is more frequently expressed in terms of a ratio of signal to noise. It has been determined by subjective tests that a minimum television video signal-to-noise ratio of 40 db is required on an overall basis. This noise ratio of 40 db is expressed in terms of a peak-to-peak signal and rms noise.

To achieve an overall signal-to-noise ratio of 40 db, the individual radio links must have a much better signal to noise ratio. For example, in a three link system, to allow for radio fading and the individual contribution of each link, a signal-to-noise ratio of at least 52 db is required per link. To accomplish this with normal receiver signal levels, the receiver inherent noise output must be in the order of 85 to 90 db below 1 milliwatt. This places very stringent requirements on receiver design and maintenance.

23.8 PATH LOSS

The free space path loss between isotropic antennas may be computed, in db, from the following expression:

$$\text{Loss (db)} = 10 \log \left(\frac{4\pi d}{\lambda} \right)^2$$

In this expression the wave length (λ) and the path length (d) are given in the same units of length. Curves have been plotted for this relationship in terms of path length and transmission frequency, and are to be found in many of the texts associated with microwave transmission engineering. A typical curve is indicated in Figure 23-5.

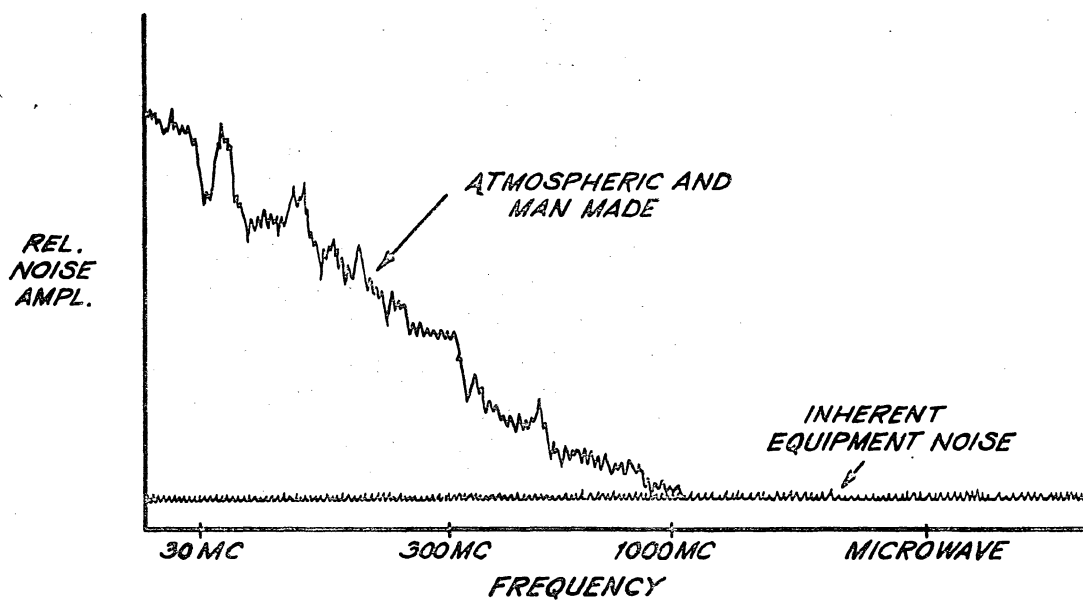

23.9

Figure 23-4 Radio Noise

PATH LENGTH D, IN MILES. USE DB SCALE ON RIGHT.

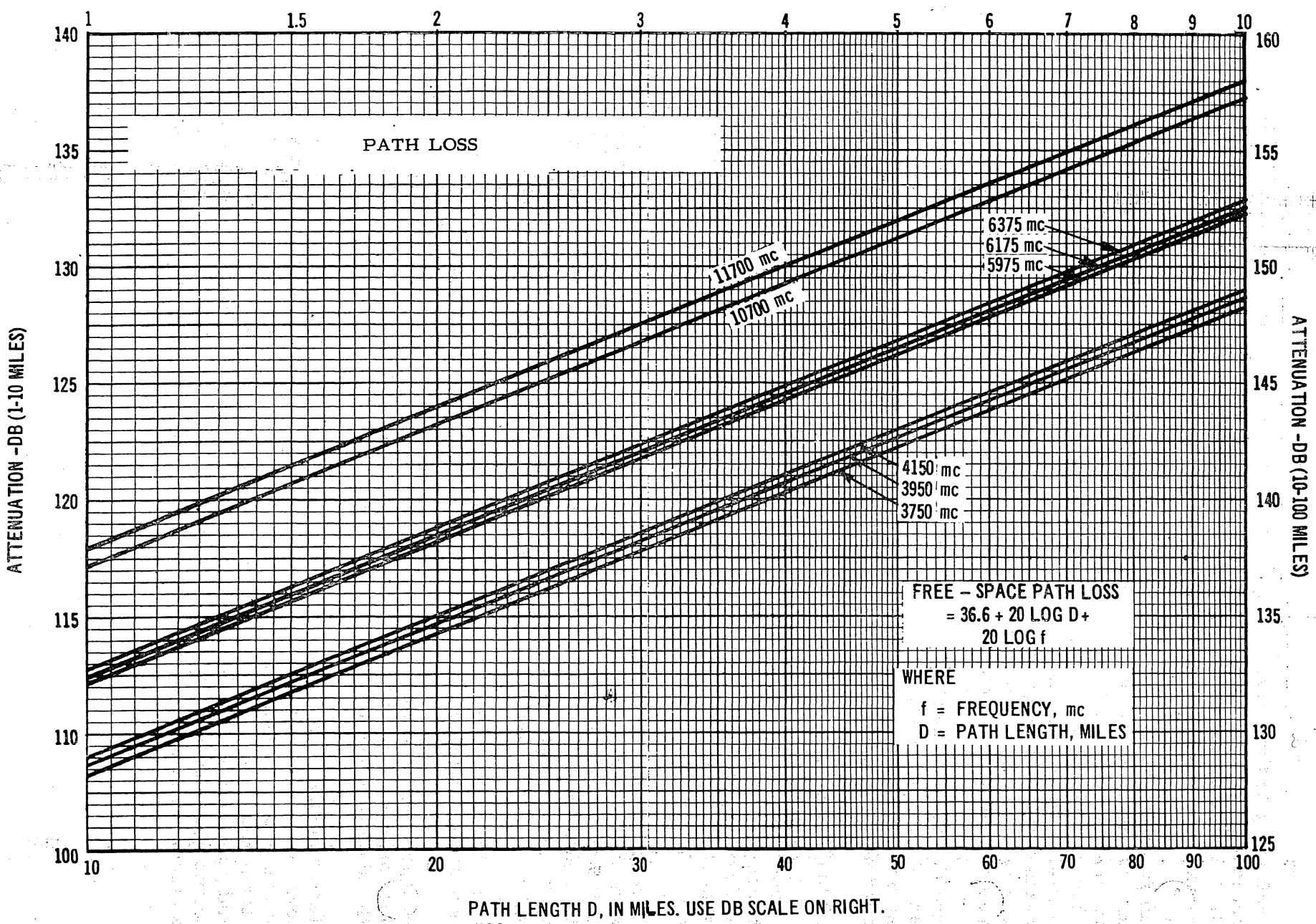

Figure 23-5 Path Loss Curve

CHAPTER 23 MICROWAVE TRANSMISSION CONSIDERATIONS

By referring to the curve in Figure 23-5 (or by using the formula) it will be found that a 30 mile path at 4,000 megacycles has a loss of 138 db. If horn reflector type antennas are used at each end of the path a gain, of 43 db per antenna can be expected. This reduces the path loss to 138 - 86 or 52 db.

In an actual measurement of such a path loss, the attenuation of the waveguide, waveguide filters and any other components included in the measuring path must be added to the 52 db to arrive at the correct overall loss. This is also true when estimating the received power at the receiver input in terms of the power delivered by the transmitting tube. In practice, it is also customary to include additional loss to care for moderate fades and this may be in the order of 10 or 12 db, which must be compensated for by the automatic gain control in the receiver.

From the above it can be seen that the gain of an average microwave receiver need not exceed 75 db. Where longer paths are to be utilized or where greater fading margins are desired, the receiver gain must be increased accordingly or antennas having a higher gain must be used.

23.9 SITE LOCATING

As previously pointed out, it is desirable to have a clear line of sight path between the transmitting and receiving antennas at microwave frequencies. The first requirement of any prospective radio relay station site, therefore, is that it be capable of providing an unobstructed view of other stations in the system with which it must work.

The requirement of line-of-sight transmission paths immediately puts a restriction on the repeater spacings that can be used. It has been found that the depth of fading of the microwave signals increases rapidly with the path length and this factor tends to limit the repeater spacings even though longer optical paths might be available. Practical paths of about 35 miles are common although spacings as great as 50 miles have been used.

As previously mentioned, first Fresnel zone clearance is desirable and this also is a determining factor in the location of microwave antennas.

The type of terrain likewise is of importance, since fading is apt to be objectionable over large bodies of water or through river valleys and such paths should be avoided wherever possible.

A further consideration in laying out a microwave route is that of over-reach interference. For example, if four consecutive repeater stations on a route are considered: transmitter No. 1 would be operating at the same frequency as transmitter No. 3 and thus could produce interference if receiver No. 4 could copy both transmitters. It is, therefore, desirable to stagger the intermediate stations slightly when directive antennas are used, increasing the amount of stagger as the directivity of the antenna is decreased, and

CHAPTER 23 MICROWAVE TRANSMISSION CONSIDERATIONS

to change the polarization of transmission each time a frequency is re-used. To select sites in accordance with the above requirements, as much information as possible is first collected on the topography of the route over which the transmissions will occur. Aerial surveys may be made or maps may be secured from various federal agencies, state and county governments, U.S. geological surveys, or even the road maps distributed by oil companies. Tentative sites are selected and their elevations plotted on a profile sheet.

The profile is normally plotted above a $4/3$ earth radius curve drawn on the paper to take into account the bending or refraction of the radio waves around the curvature of the earth. The vertical scale of the profile is in feet of elevation and is plotted accurately to ten or twenty feet. The horizontal scale is usually in miles.

Having established tentative site locations, by means of the topographical maps and the profile sheets, which will give suitable path loss and suitable clearance, it becomes necessary to determine whether the locations will meet other requirements. Among these are interference due to over-reach; interference due to buildings or large objects, such as water tanks, which might appear on the maps; interference from other services operating in the microwave region; right-of-way problems, especially access to the location for personnel and vehicles; availability of power supply; access to other telephone plant facilities for order wires; line connections, etc., and whether the tower heights required for adequate clearance are sufficiently remote from air fields to receive concurrence by the Civil Aeronautics Administration. It has been found that even though a particular site may meet all requirements for satisfactory transmission, it still cannot be used because of excessive price or regulations. It is therefore necessary to make preliminary field inspections and wherever possible select alternate sites for each of the preferred sites along a route.

As a final check, it is desirable to make actual tests of the line-of-sight, which may be done either optically or electrically. For a rapid check, a sealed beam type of spotlight, which is prefocused to provide nearly parallel light, is available. This is rated at 40 watts and operates from 6 to 8 volts.

A spotlight may be equipped with a flashing device to permit easier identification and can be used up to distances of 30 miles. This technique is suitable for many of the shorter paths, but may not be adequate for establishing first zone clearance on longer paths. In such cases, a path loss testing set, which consists of a portable transmitter and portable receiver, is available. These may be set up at the respective site locations and an actual measurement made to accurately check the location of reflection points.

CHAPTER 23 MICROWAVE TRANSMISSION CONSIDERATIONS

23.10 STRUCTURES

Many types of physical arrangement of building, antennas and towers have been used, depending upon the location and degree of permanence of the service. On main routes using TD type of service, permanent buildings are usually provided of concrete or concrete block and provision made for adequate emergency power installation such as engine driven alternators. On side-leg routes or routes involving temporary service, prefabricated metal or wood buildings may be used. Wood is not recommended, however, if gasoline engines are to be used for emergency power. At the terminals of radio routes, where possible, the equipment is mounted at the top of telephone buildings or other high buildings, using existing space or adding penthouse structures.

Antennas may be mounted on heavy four leg towers, structurally designed to handle four to eight of the horn type radiators. In other cases, it may be desirable to use an A frame type of tower, with a reflector suspended at the top, and the antenna mounted at ground level. This is frequently done on side-leg routes where the parabolic or dish type antennas are used. In such cases, consideration must be given the antenna location. It may be placed inside, close to the transmitter and an electrically transparent window placed above it.

Several window materials are available and include both plain window glass and plexiglass. A composite material utilizing two facing sheets of fibre-glass, separated by a core, is manufactured by the U. S. Plywood Corporation and has been found to be quite satisfactory. Flat glass or flat plexiglass has introduced difficulty due to reflections and, therefore, is usually made up in the form of corrugated sheets. When window materials are used, they should normally be placed at an angle of at least 15° to the radio path to avoid undesirable reflections back into the transmitter.

When a dish type antenna is placed horizontally outdoors, provision must be made for drainage and for the melting of snow and ice that may collect in it. Provision must also be made for avoiding a collection of leaves and debris. In some instances, the antenna has been mounted to radiate horizontally into a reflector which redirects the energy upward to a second reflector at the top of a tower. This in turn directs the energy horizontally in the desired line-of-sight. Whether transmission is directly from antenna to antenna, such as in the lens type radiators, or whether it is from antenna to antenna through one or more reflectors, provision must be made for properly orienting the transmitting antenna, the receiving antenna and the reflectors, so that maximum energy is received for a given power output. This orientation becomes quite complex as additional reflectors are included in the transmission path. In addition to proper directivity, the receiving antenna must also be checked for polarization, since under some conditions there may be a shift in polarization of the transmitted signal.

CHAPTER 23 MICROWAVE TRANSMISSION CONSIDERATIONS

A further complication appears in the form of antenna lobes. A directive antenna is assumed to radiate its energy in a narrow angle which gives a transmission pattern resembling an elongated tear-drop, called a lobe. Unfortunately, with practical designs, additional pairs of lobes of much less intensity are usually to be found at an angle to the main or major lobe. It is, therefore, possible to orient antennas so that the energy is being transmitted and received on minor radiation lobes. A check of measured path loss versus computed path loss will quickly determine whether or not this is the case.

23.11 ORDER WIRE AND ALARM CIRCUITS

Although order wire and alarm circuits are not generally made up of microwave components, a microwave system is incomplete without them. Microwave repeater stations are normally unattended and there must be a means of communication between stations and between stations and control offices for the use of maintenance men on routine and trouble locating trips. Alarm circuits are essential to keep the terminal offices informed of the operation of the intermediate points. Such alarm systems run the gamut from very simple to very complex arrangements. A more complex alarm system will indicate loss of received RF signal, loss of transmitter power output, loss of commercial power, starting of the auxiliary power plant, open doors or windows, fire, fuse alarms, and many other types of information. These alarm circuits may also be used for control functions and permit the remote turning on or turning off of equipment, starting of gas engines for test runs, remote switching of side-legs from one channel to another as well as many other special functions.

Where wire facilities are not available, it is possible, with permission of the Federal Communications Commission, to use a paralleling microwave system to furnish the order wire and alarm circuit facilities.

CHAPTER 24

GENERAL CONSIDERATIONS INVOLVING CARRIER SYSTEMS

24.1 INTRODUCTION

It is well known that any one of the 50 million telephone subscribers in the Bell System can talk to any other, and further, that he can expect the connection to be established quickly and that the charge will be reasonable for the service rendered. When one realizes the many out-of-way places in which telephones are located, and the devious routes by which the connection may be established, this performance looms large as a technical achievement. Thirty years ago there were only 36 long distance circuits whose length exceeded 1,000 miles. Today that number has increased more than one hundred fold.

For many years, the medium used to connect two remotely situated subscribers has been divided into two parts, the exchange area system and the toll or long distance system. Just as faster and faster airplanes have removed the seeming impediment of distance, so do improved mechanical means of switching tend to make artificial the distinction between local and long distance service. Rather, the distinction is one of the toll or charge to be billed against the customer for the extended range of the service. Even this point of view may be brushed aside as we gaze hopefully into the crystal ball and see future transmission systems carrying thousands of messages from coast to coast at such a low cost that they will perhaps necessitate a charge of only a few additional message units.

Needless to say, this bright vision of essentially local service on a nationwide basis will not be had merely by wishing for it. The present state of the art has been reached through continuous efforts to bring about improvements and economies and by planning to take advantage of each new advance as it materialized. The over-all telephone system is today divided into exchange and toll categories.

The transmission afforded by the toll plant must always be considered in combination with that provided by the local plant. While this must always be so, the philosophy of working each intertoll trunk at the maximum of its capability tends to divorce toll circuit design from the exchange area design.

The great increase in the number of long toll circuits was made possible by the advent of high velocity carrier circuits. By virtue of careful design, noise and crosstalk have been relegated to secondary importance so that echo tends to be the controlling factor in circuit design.

CHAPTER 24 GENERAL CONSIDERATIONS INVOLVING CARRIER SYSTEMS

24.2 CHARACTERISTICS AFFECTING USE OF INTERTOLL FACILITIES

There is no simple formula sharply defining the fields of use of various types of intertoll facilities. Over-all economy should determine the instrumentality selected for each installation. Intangible factors may well take precedence over simple dollar calculations. For example, the use of a radio system to parallel an existing landline, rather than to provide a less costly relief of like type, may be justified in some cases purely from the standpoint of continuity of service. Such a decision would be based on the fact that the likelihood of simultaneous failures involving both types of systems is very remote.

Figure 24-1 lists the principal toll systems in the order of their velocities of propagation. Echo becomes more critical as the velocity is decreased. Echo is the primary consideration today in determining minimum allowable circuit loss. Other conditions being equal, the nearer the top of the Table, the lower the permissible net loss of the facility.

PREFERRED ORDER OF CHOICE OF INTERTOLL FACILITIES FROM THE STANDPOINT OF ECHO	
<u>Choice</u>	<u>- Facility -</u>
Best (High Velocity)	Radio System Channels (All Types)
"	Type L Cable Carrier
"	Open Wire Carrier Systems
"	Type K, N or ON Cable Carrier
"	VF Open Wire or 4-Wire Light Loaded Cable
"	VF 4-Wire Medium Loaded Cable
Poorest (Low Velocity)	VF 2-Wire Loaded Cable

Figure 24-1

Since all types of voice-frequency facilities are gradually being superseded by carrier circuits for intertoll usage, we will confine the following discussion to carrier systems.

In practice, system lengths are subject to considerable variation. The minimum length is determined by the relative costs of line facilities and terminal equipment. Maximum length is determined by fundamental system design and the noise and crosstalk performance of the line facility. Development of systems to work over long distances requires particular attention to regulation, distortion, and system noise problems. Components of the terminal equipment must be manufactured to finer tolerances as the intended length of the system is increased.

CHAPTER 24 GENERAL CONSIDERATIONS INVOLVING CARRIER SYSTEMS

The number of systems that can be operated in parallel on a given route is determined principally by the refinement of design and care in construction of the outside plant. This is particularly true of open wire systems. By sacrificing channels and limiting system length, use is frequently made of open wire that is of a grade materially lower than that contemplated when the system was developed.

Systems Listed in Approximate Order of				
	Ultimate Route Capacity	Line and Repeater Costs per Circuit	Terminal Costs per Circuit	Flexibility
Least	O1	L3	N1	L3
	N1	L1	O1	L1
	K	ON	ON	K
To	ON	N1	K	N1
	L1	K	L1	ON
Most	L3	O1 ⁽¹⁾	L3	O1

NOTE:

(1) The line costs for O1 vary over a very wide range, depending on circumstances, and on some routes may be less than for ON or N1 and on others more than for K.

Figure 24-2 Summary of Characteristics Affecting Field of Use of Carrier Systems

Figure 24-2 lists some of the more common systems in relative order with respect to characteristics which determine their selection for a specific application. (Flexibility indicates the smallest block of channels that can be conveniently dropped off at intermediate offices along the route.) Other pertinent considerations not shown in the Table are:

- a. The system must be capable of providing an acceptable quality of transmission over the distance to be spanned.
- b. If existing outside plant is to be employed, it must be made suitable for the proposed system. This work may be an important factor in the cost of a project. Voice-frequency loaded cable must be deloaded for carrier operation. Cable pairs to be used for K carrier require special treatment to minimize crosstalk. K, N or ON routes may need protection against the influence of noise from external sources. Realizing the ultimate higher frequency carrier capacity of an open wire lead usually entails extensive transposition rearrangements. L3 cannot be substituted for L1 without substantial expenditures for new repeater stations.

CHAPTER 24 GENERAL CONSIDERATIONS INVOLVING CARRIER SYSTEMS

- c. The proposed system must be compatible with those already in operation on the route. Type J and higher frequency O systems usually cannot be operated on the same lead. Only under the most favorable conditions can N or ON systems be added to a K carrier route without sacrificing several channels per system.
- d. If the system does not have suitable built-in signalling features, the cost of the necessary auxiliary equipment must be considered.
- e. The type and capacity of available power plants may be an important consideration.

As with the choice between the several types of carrier systems, there is no unique field of use that may be said to be assignable to radio in preference to the construction of land line facilities. Each case must be studied on its own merits, and considerations other than the purely economic ones may be controlling. Generally carrier is most economical around 15 to 25 miles.

Any system for giving a particular type of service is under constant pressure from a variety of forces. These may result from natural growth, competition based on new discoveries or improved arts, need for increased revenue, or greater efficiency. Generally, all these forces are acting at all times, though one will usually be more significant than the others. An effort to maintain the status quo in a system tends to make it outmoded because of the very considerable effort toward improvements in present-day industrial research. On the other hand, a coordinated effort to apply new devices to existing systems tends to improve the economics of operation and at the same time to give better service.

24.3 THE INCEPTION OF A NEW SYSTEM

Growth, expansion, and change are stimuli which are within the experience of each one of us. They appear in plant, animal, social, and economic life and they also appear in industrial life. In the telephone business, these forces are constantly at work and it is the operating telephone people who feel them at the customer level and interpret them into telephone needs. Frequently these needs cannot be met by existing arts, and further study will indicate the need for a new system. Needs are not the only factor. Sometimes research and invention indicate that a task can be performed by new methods which are faster, better, and more economical. Depending on the degree of improvement, the new system may be installed where plant extensions are required or it may actually be used to replace existing plant. It is the purpose of this section to touch briefly on some of the factors which individually or in combination may lead to the inception of a new system.

CHAPTER 24 GENERAL CONSIDERATIONS INVOLVING CARRIER SYSTEMS

Functionally there are three main organizations involved in recognizing the need for a new system. First, there is the operating telephone company which is the consumer of a new system, and which is in best position to know the needs of the customers. Then there is the American Telephone and Telegraph Company which acts as a co-ordinator among the various operating companies, analyzes transmission problems, advises on policy and problems too complex for an individual company, and confers with the Bell Telephone Laboratories regarding the needs for new development. Finally there is the Bell Telephone Laboratories which is primarily concerned with research and its application and the improvement of existing systems. There is also some contact at the higher organizational level of the Laboratories with the operating telephone people, generally in company with representatives of the American Telephone and Telegraph Company.

The operating telephone companies are directly concerned with the collection of revenues and the payment of operating expense. They are therefore acutely aware of situations which tend to increase expenses and they are likewise cognizant of the need for any service which would increase revenues. To keep abreast of the situation, they make provisional estimates which include the best guesses concerning plant requirements for the future, sometimes projecting as much as 3 to 5 years ahead. These studies include estimates concerning the direction and amount of population growth and the most economical means of handling the traffic. As an example, it may be shown that the traffic between two moderately sized cities forty miles apart will double in 5 years due to an increasing community of business interest. Since the present traffic utilizes practically the ultimate development of the existing plant, it will be necessary to increase the capacity by the same type of plant or to find some new medium.

The American Telephone and Telegraph Company will be informed of the expected expansion and need. It may receive similar information from other companies and may then poll those remaining as to whether or not they expect such situations to arise. If there are sufficient affirmative answers, the American Telephone and Telegraph Company will transmit to the Bell Telephone Laboratories, through suitable channels, a statement that a new transmission system is needed which can operate over existing facilities and prove in economically over additions similar to the present facilities which might be 19-H-88 loaded cable with or without repeaters. The solution might indicate development of a new carrier system which would be radically cheaper than any heretofore produced. This period of discussion leading up to the decision to go ahead would be called the inception of the new system.

Similarly, provisional estimates might be expected to indicate the need for improved telephone sets, negative impedance repeaters, community dial offices, or rural radio.

CHAPTER 24 GENERAL CONSIDERATIONS INVOLVING CARRIER SYSTEMS

High-level management must at times indicate the need for new systems because of its recognition of social trends. This source of inception may be a deciding factor in cases that would otherwise tend to be indeterminate. In this category might be placed such systems as transoceanic radio, vehicular radio, and the rapid advance of a coaxial network which can be used for television if the demand arises.

Members of the Laboratories are also in a favorable position to bring about the birth of a new system. Because of their familiarity with existing systems, they are in a particularly good situation to recognize the applicability of new devices resulting from research and development.

When new systems originate within the Laboratories, the focusing is in the reverse direction. This takes place by sending a development letter, generally called a DL, through lines of organization to the American Telephone and Telegraph Company, calling attention to the new development, stating its important transmission characteristics, cost, and field of application. The American Telephone and Telegraph Company in turn transmit this information to each telephone company, requesting data concerning the possible number of applications and inviting further inquiries.

The foregoing discussion has indicated the means by which information concerning the need for a new system or the availability of a new system is focused into the proper channels for action. It will now be of interest to investigate in somewhat more detail the procedures within the Laboratories by which the general requirements are set up, which in turn lead to the still more detailed design of circuit components.

System Requirements

Having decided that there is need for a new transmission system, it next becomes necessary to specify more completely the conditions under which it will work so that the transmission engineer can set up some general transmission requirements. In any such development, it is always necessary to do a certain amount of looking ahead at the transmission aspects in order to reach more general conclusions. This tends to make the distinction between inception and planning a rather artificial one which is mainly useful for purposes of discussion. In many developments, progress is in the nature of ever-widening circles, based on a central core or idea.

As a starting point, the broad objectives are restated with boundaries which fix the scope of the system under consideration and indicate the probably direction of detailed investigation. This review is made at a conference or series of conferences attended by representatives of those departments who, because of prior experience or present aptitudes, are in a position to contribute most to the ultimate development. Among the matters resolved about the new system will be such questions as: How will it fit in with existing

CHAPTER 24 GENERAL CONSIDERATIONS INVOLVING CARRIER SYSTEMS

plant? Will it require new and unfamiliar types of maintenance? In what sort of traffic will it be used - tandem trunk, interoffice trunk, single or multilink toll connection? Is it amenable to growth? Does it possess flexibility with regard to transmission losses and traffic handling capacity?

The result is a broad statement indicating such decisions as

1. Transmission must be satisfactory over a particular gauge in aerial cable, under certain extremes of temperature.
2. A carrier system will be used.
3. Each carrier system should have not less than a certain number of channels, four, for example, and need not have more than eight channels.
4. The cost must be as low as possible and must not exceed a specified limit.
5. The system will be used as a terminating circuit; that is, it will not be used in tandem with other circuits on each side.
6. Voice-frequency signaling will be used.

These conclusions are tentative and some may be based on information provided by certain of the conferees who are familiar with current technical developments.

At this stage it becomes possible to draw a schematic in box form, indicating the basic circuit functions such as filtering, modulating, amplifying, mixing, and demodulating.

The early planning is an extremely important part of the work and requires considerable knowledge and familiarity with the existing telephone plant. A carefully considered plan will take into account such things as the possibility of additions, changes in transmission or operating requirements, and the possibility that the initial requirements are not complete. On the other hand, a plan which adheres strictly to a stated requirement may necessitate later changes which are expensive, particularly if they must be made in the field. Obviously the cost is a factor and it is not reasonable to spend money unnecessarily, but if on the other hand it is possible to devise an arrangement of greater potential at very little or no extra cost, it is a wise plan to adopt.

Formulation of Transmission Requirements

Having decided upon a rough schematic of the new system, it becomes necessary to specify in quantitative transmission terms exactly what function each block shall perform and under what condition it shall work. As in most

CHAPTER 24 GENERAL CONSIDERATIONS INVOLVING CARRIER SYSTEMS

phases of development work, there is a considerable amount of discussion back and forth, consideration from all viewpoints, evaluation of one type of element relative to another or one method versus another. This progress is generally not continuous in a single direction, proceeding from the original objective to a completed circuit element. It is more like a drift containing the Brownian movement of physics in which progress is in discrete steps, frequently moving sideways or even backwards when it bumps into the impedance of another related component. This represents compromise and it results from weighing the relative importances in the best interest of the ultimate objective.

Each of the various schematic boxes must be separately considered so that its performance is satisfactory and integrates with the other boxes to provide an over-all assembly which possesses the economic advantage that is desired. The importance of the cost angle must be constantly in the forefront of consideration.

The result of these analyses, which do contain a certain amount of forward looking, backward looking, and assumption, is a tabulation of significant quantities which will enable the circuit and apparatus designers to specify existing circuit elements or design new ones. These points are extremely important as they bear directly on the future activities of a good many people, and an error in decision which costs manpower is a grave matter, particularly at times when a shortage of manpower is incident. It is not to be expected that perfection will be achieved immediately but it is a worthy objective in any and all problems. Some of the quantities derived and their significances are discussed below.

Noise is a determining factor in all design problems. Basically, telephone transmission is satisfactory when the customer receives his message at a loudness which is such that the noise present is not a disturbing factor. This relationship is described by the signal-to-noise ratio, frequently written, S/N , and is well known from long experience with the problem. The required value of S/N depends on the type of service and the point in the circuit being considered. It is important throughout the system, regardless of the frequency or nature of the signal. Noise is important to the new system from two points of view: first, that which is introduced into the system by its own components. Needless to say, components must be so designed that they do not act as noise sources to other systems. This last point is one of the "broad system" aspects which arises when it is proposed to introduce a "new" system were to be the only system of any sort in operation. A very acute example of this systems aspect arises when a radio link intended for point-to-point service is integrated into an existing system.

CHAPTER 24 GENERAL CONSIDERATIONS INVOLVING CARRIER SYSTEMS

Knowledge may be lacking when a new system is proposed for operation in an area which has heretofore been unexplored. In such a case, it may be necessary to make assumptions regarding the noise, based of course on computations, extrapolations, and best guesses. These should be justified as soon as possible by measurements in the proposed field of application of the new system.

Level of the signal is closely related to noise and is a very important parameter in determining the choice of such components as modulators, tubes, magnetic elements, or nonlinear elements. There are two important aspects to level. The first is given by the ratio of signal level to noise and the second is the variation in the level of the signal from its average value. The necessity for knowing the S/N ratio gives rise to the level diagram which plots the level of the average signal (or a test tone) and the noise at various points in the over-all system. By means of this chart it is possible to fix the relation between gain and spacing of repeaters. The distribution of signal powers in an amplitude system determines the maximum power handling capacity of an element at a given level point. This interrelationship in a wire transmission system of repeater gain, spacing, and size of tubes is an important one which must be worked out on a cost basis, taking into account such imponderables as accessibility of repeater locations and maintenance.

The crosstalk problem involves unwanted transmission into or from the circuit under consideration. Its importance depends on the magnitude of the coupling between the two circuits and is generally expressed as a decibel loss. The amount of crosstalk power delivered into the disturbed channel is related to the levels; hence, these two factors, coupling loss and level, must be properly co-ordinated. Crosstalk coupling may exist by virtue of direct capacity coupling, as between two adjacent pairs in a wiring plan or cable. In this case, the loss decreases with increasing frequency because of the nature of capacity reactance. It also depends on the construction of the cable with regard to the length of a twist in the pair, the arrangement of color groups, the nature of the insulation, and other factors. In open-wire lines, the crosstalk is by inductive means and depends on such factors as spacing of pairs, position on the crossarms, and transpositions which are analogous to the twist of cable pairs. Crosstalk may also occur indirectly through an intermediate coupling path. It is sometimes denoted by the position in the circuit at which it occurs, such as near end or far end. When crosstalk does occur, its effect is generally to place a penalty on some other factor such as repeater spacing. The art of ameliorating crosstalk effects is important and highly developed and is of course co-ordinated through the medium of cost studies to determine the most economical system. The resultant figure is adopted as the allowable crosstalk, subject always to later revision if developments indicate that such action is advisable.

CHAPTER 24 GENERAL CONSIDERATIONS INVOLVING CARRIER SYSTEMS

The permissible level of cross modulation relative to the signal is stated for multichannel systems. This factor will have a bearing on the linearity of amplifiers, the types of modulators and demodulators, and the discrimination of filters. It is generally more severe for higher signal powers; hence it enters into consideration of the number of channels and the power handling capacity of circuit elements such as magnetic cores and vacuum tubes. A figure is chosen which represents the best compromise among these several factors.

The frequency band in which the signal is to be transmitted must be fixed as the result of a rather critical review of a set of somewhat complicated interrelated factors. In a typical cable, an increase of frequency makes the crosstalk problem more acute. It also increases the attenuation, but tends to have compensating effects because the difference in attenuation at the two ends of the band decreases for a given bandwidth and the effects of temperature variation are more conveniently handled. In open-wire lines, an increase of frequency tends to increase difficulties, due to noise of an impulsive type, such as static; to make the crosstalk problem more severe; to make the matter of bridging circuits more difficult because of quarter wave length phenomena; and possibly to interfere with or be interfered by low-frequency radio propagation. The number of channels to be transmitted determines the bandwidth and thereby affects its location because as already pointed out there are advantages to keeping the band as narrow as possible on an octave (or per cent) basis. The location and width of the working band is chosen as a result of these considerations.

Signaling is a necessary operation to prepare any telephone connection for the talking condition. Bearing in mind what has been said about good planning, it is desirable to consider the best means for including signaling in the new system. This must resolve the question of whether it is cheaper to apply existing techniques or to develop entirely new methods; whether each channel should signal over its own transmission channel or all signaling should be over a separate channel restricted for that purpose only.

Protection of the new system from foreign potentials must be accounted for. Likewise, the system must be restricted to maximum voltages which are not hazardous to operating personnel or possible sources of fire in case of failure. Underwriter laboratory rules must be carefully considered in this connection.

Power supply is always an important factor in the cost of a new system, especially if it must be supplied at remote points. The need for a reserve power supply in order to insure continuity of service is sometimes an expensive item which weighs heavily in the ultimate choice of both power supply and routing of the new system. Power is sometimes supplied over the channel conductors or added conductors where maximum economy is essential, but it must be counterbalanced by the significance of voltage drop in the lead wires and regulation at the point of consumption. These

CHAPTER 24 GENERAL CONSIDERATIONS INVOLVING CARRIER SYSTEMS

matters also bear on the type of tube which is to be used and vice versa so that ultimately power supply, tube type, tube gain, tube power handling capacity, and repeater spacing are all interrelated in typical systems fashion. A choice is reached after proper consideration of the various angles.

Maintenance is a continuing expense; hence, it also is a factor in formulation of a new transmission system. Circuit elements which have long life, uniformity, ease of manufacture, and low cost must be chosen or designed. Maintenance also affects the arrangement and accessibility of parts.

The final formulation for the new system results when the various factors indicated above have been thoroughly co-ordinated by all the groups interested in the problem. This formulation enables filling in the characteristics of the boxes in the block schematic and represents the best way of laying out the new system, in the judgment of those who have participated. At this stage, the plan must be reviewed at the top executive level where approval is given for the general arrangement, and authorization is granted to proceed with the detailed design of the components which will go into the manufacture of the system.

The executive authorization to proceed with the development brings about a considerable change in the character of the effort expended. Up to this point the work has been on a broad basis with some of it being on an exploratory and speculative basis. This planning stage is therefore charged to the telephone companies in accordance with the contractual obligation to assist them in realizing the benefits of scientific research and development. In the detailed design stage, which follows thereafter, there is a need for injecting specialized knowledge, experience, and skill into the project. Accordingly the over-all plan is broken into its various parts, with the result that the number of people engaged in the work is greatly increased. Since the design effort in this next stage is directed toward the production of physical components, the work is charged to the Western Electric Company which will manufacture the parts and assemble and install the system for sale to the telephone companies.

Design Stages

Having acquired full approval and general agreement up and down the line of organization for the general formulations of the new system, it next becomes necessary to convert the ideas expressed into a working reality. The work is parceled out as agreed and the designers begin to assemble tubes, resistances, condensers, and other components into a circuit arrangement which it is believed will perform the desired function in the most satisfactory manner.

CHAPTER 24 GENERAL CONSIDERATIONS INVOLVING CARRIER SYSTEMS

All that has been said concerning the advantage of planning of good system applied with equal force to planning a good design to perform one of the necessary functions within the system. A few of the attributes which might be mentioned are the following: The design must be economical to build and operate; it must be rugged in construction; it must have long life and low maintenance with easy replacement of parts; it must be uniform in performance with a minimum effect from circuit variables; and it must be easy to manufacture and install with the adjustments made noncritical, not interdependent, and few in number. These attributes are not easy to meet, and so once again design planning of the highest type is the order of the day.

To carry out the design, it is desirable to analyze the formulations in critical fashion to be sure that none has been omitted and to be certain that those stated are correct. It will be recognized that a number of different groups are designing at the same time, all aiming at the same objective of producing a good circuit function element at a specified future time. This time element is important, for if 10 per cent of the work is unfinished, the whole system is unfinished. To reach completion sometimes requires a pragmatic compromise with perfection. As each design group progresses, a very close co-ordination is necessary to insure that changes deemed necessary by one group are known by all so that any adverse effects may be compromised and any unforeseen advantages evaluated and utilized.

The result of the design work in a group is to produce a "breadboard" model which is the physical embodiment of the working principles, but which lacks the physical arrangement and wiring of parts that go into a final model. The term had its origin in the fact that designers working in the laboratory found it convenient to fasten their circuit elements to a breadboard of the type used for rolling out pastries in the home. In the successive stages of design, it is quite common to transfer the model to a metal plate, particularly if the circuit operates at relatively high frequencies. Although the term "brass board" has sometimes been applied to this step, it is commonly understood to be included in the general process of breadboarding. The development of a breadboard model is a continuous process of adjustment and measurement, aimed at evaluating such factors as variability of precision in manufactured circuit components, aging effects, changes in operating voltages, and changes in temperature. At the same time it is necessary to be on the lookout for second-order effects such as unwanted mutual impedances between circuit meshes or between one panel and another (possibly that of another designer), excessive levels, unexpected noise sources, modulation products, or longitudinal effects.

Inevitably, breadboarding leads to some changes in design and sometimes to a revision of the initial requirements. These may result due to some new outside developments reaching fruition after the start of the design or from failure of an element to perform its intended function satisfactorily. Within a given breadboard there may be one or more pieces of new apparatus each of which represents a design project to which all the usual criteria have been

CHAPTER 24 GENERAL CONSIDERATIONS INVOLVING CARRIER SYSTEMS

applied. Thus, within a MODulator-DEMulator unit there may be new amplifiers, new filters, and new varistors contributed by specialist designers who turn them over to the circuit designer of the modem unit who is doing the breadboarding.

Equipment designers will be working somewhat in parallel with the circuit man to provide a permanent mounting and wiring arrangement of the breadboard model. These two groups will prepare manufacturing information from which the final product is turned out. Standardization is an important aspect at this stage and a critical review is made to be sure that the maximum number of standard coded elements has been used, and that the number of new codes has been minimized. The importance of this point will be appreciated when it is realized that drawings must be on file, machinery designed and stored, and raw materials stocked for each and every coded item. This requires a large investment in space and material and is a very expensive proposition, especially for items of small demand.

After a lapse of time during which there has been much co-ordination, compromise, advance, and retreat, each design group will arrive at its breadboard model and manufacturing and testing information will be prepared. The Western Electric Company then manufactures and assembles a small number of tool-made models according to the specifications, and if the future production is expected to be large, the samples may actually represent trial production from a pilot plant set up to gain manufacturing experience. These models will then be used for a limited scale trial installation, the location of which will be arranged by the American Telephone and Telegraph Company in co-operation with the operating telephone companies. In turning out the tool-made sample, there is likely to be considerable collaboration with the designers to iron out kinks which show up in the specifications and testing routines. The extent of this collaboration might involve sending a Bell Laboratories man to assist the Western or, conversely, the Western might send a man to learn more about circuit functioning.

Design of testing equipment for the operating field people must proceed in parallel with the design of the system. This is particularly true when the system operates by virtue of a new or unfamiliar technique. The designer may have such tools as part of his stock in trade but frequently they are not in suitable form for field use. He must therefore modify the form or design new test equipment, bearing in mind all the foregoing discussion and adding to it the cardinal principle that test equipment must be an order of magnitude more precise than the quantity it is intended to fix.

Before full-scale production is started, it is customary to subject the new system to a period of field testing. At this point it will suffice to say that field conditions can never be fully duplicated in the laboratory and therefore they may show up weak points in the new system. When such is the

CHAPTER 24 GENERAL CONSIDERATIONS INVOLVING CARRIER SYSTEMS

case, ways must be found for correcting the deficiency, and appropriate changes made. The proper co-ordination must be effected all through the design organization to be sure that changes which are made cure the ill and do not transfer it to another member. Manufacturing specifications and testing routines must also be modified, as needed.

Part of the objective of field trials is to obtain information and experience which will assist the transmission engineer to write the necessary material for Bell System Practices, which are a body of instruction and information written for the help of the telephone company engineers. Since they are to be delivered to the operating companies, they are released by the American Telephone and Telegraph Company, which also writes certain ones. However, the more technical aspects are drafted by the Laboratories and submitted to the American Telephone and Telegraph Company for its comments. This division of work is somewhat fluid and is fixed by mutual agreement, hinging on such factors as man power and complexity of the transmission system.