

COMPUTERS

a n d A U T O M A T I O N

D A T A P R O C E S S I N G • C Y B E R N E T I C S • R O B O T S

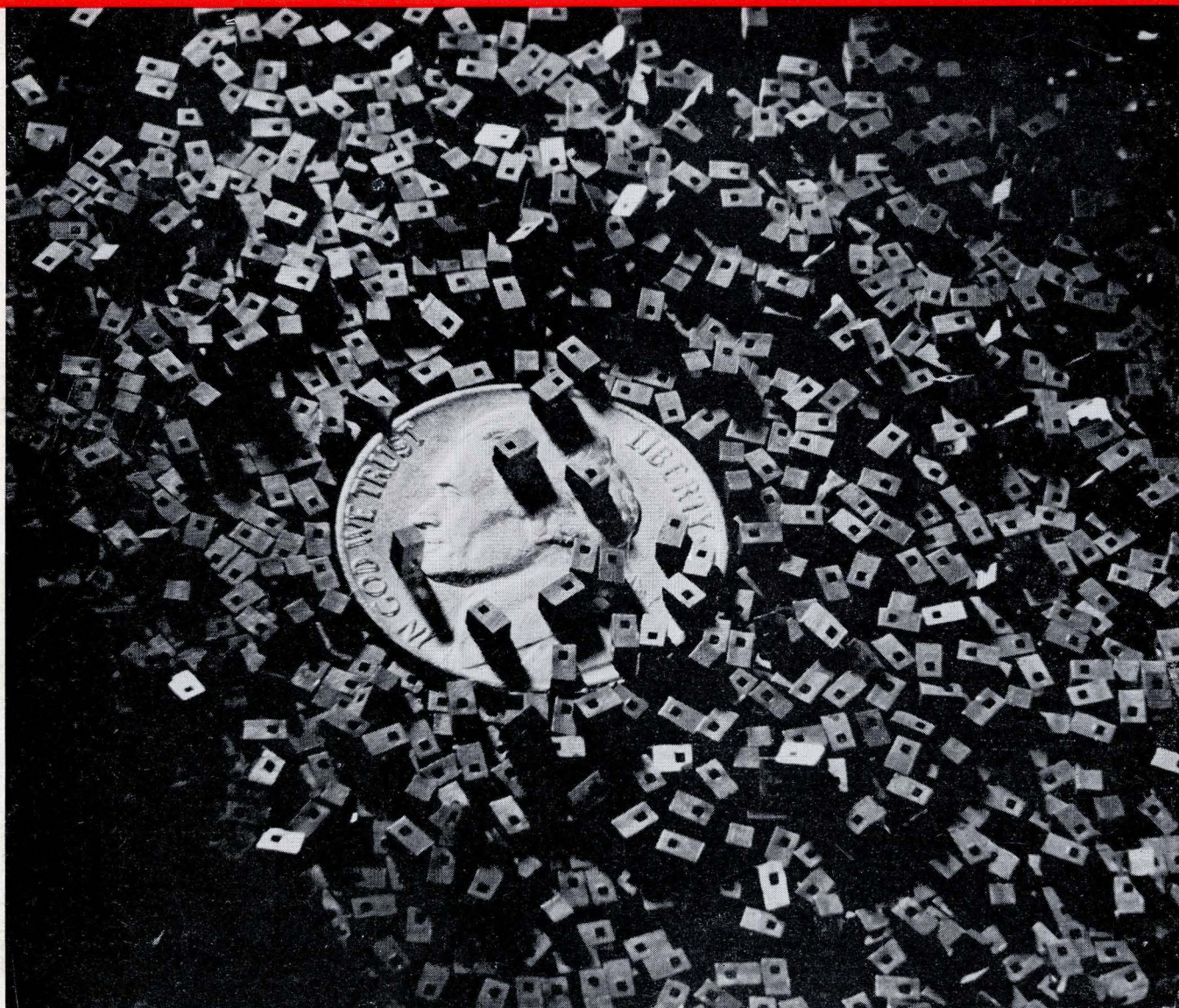

**A New Magnetic Device for Memory and Logic
The Demand for College Training in Digital Computing
Automatic Searching of Chemical Literature**

NOVEMBER

1959

•

VOL. 8 - NO. 11

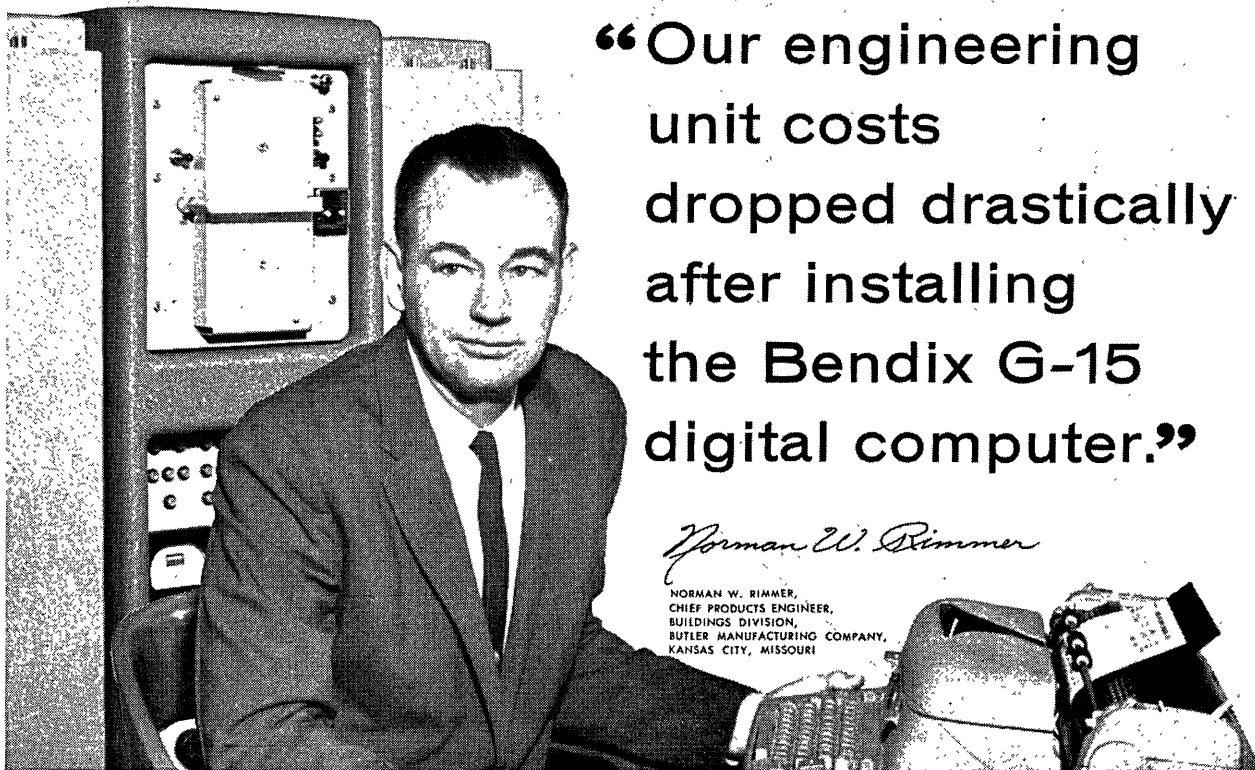

“Our engineering unit costs dropped drastically after installing the Bendix G-15 digital computer.”

Norman W. Rimmer

NORMAN W. RIMMER,
CHIEF PRODUCTS ENGINEER,
BUILDINGS DIVISION,
BUTLER MANUFACTURING COMPANY,
KANSAS CITY, MISSOURI

Butler's progressive engineering program requires a fast, versatile, and low-cost computer. It must handle complex structural problems and still be simple enough to be used by engineers with no programming experience. The computer's mission: cut engineering unit costs. *“Our own survey proved that the Bendix G-15 digital computer could best do this job,”* says Mr. Rimmer, *“and it does.”*

For Butler, part of the cost-cutting versatility of the G-15 stems from the variety of programming methods they can use. For the solution of repetitive problems at highest speeds, they use the machine language system. With the simplified Intercom 1000 system, the entire staff uses the computer for structural design problems. This versatility also means the G-15 can be used for business data processing as well as scientific and design calculations.

Butler is also pleased with the expandability of the G-15. They know that as their computing requirements grow, they can add

magnetic tape units, punched card equipment, digital differential analyzers, plotters, and other accessories. Remember, however, that the basic G-15, which includes a unique photo-electric tape reader-punch and alphanumeric typewriter, is more than adequate for most problems.

Find out more about this computer — the *only* medium-scale computer in the low-price field. Inquiries regarding specific applications are welcomed.

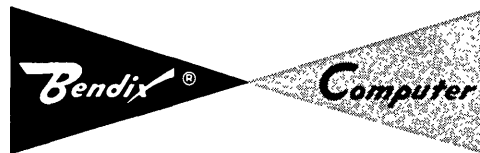
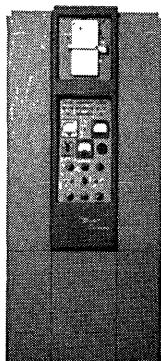

DIVISION OF BENDIX AVIATION CORPORATION

Dept. D-16
Los Angeles 45, California

PHILCO BRINGS YOU THE WORLD OF TOMORROW TODAY

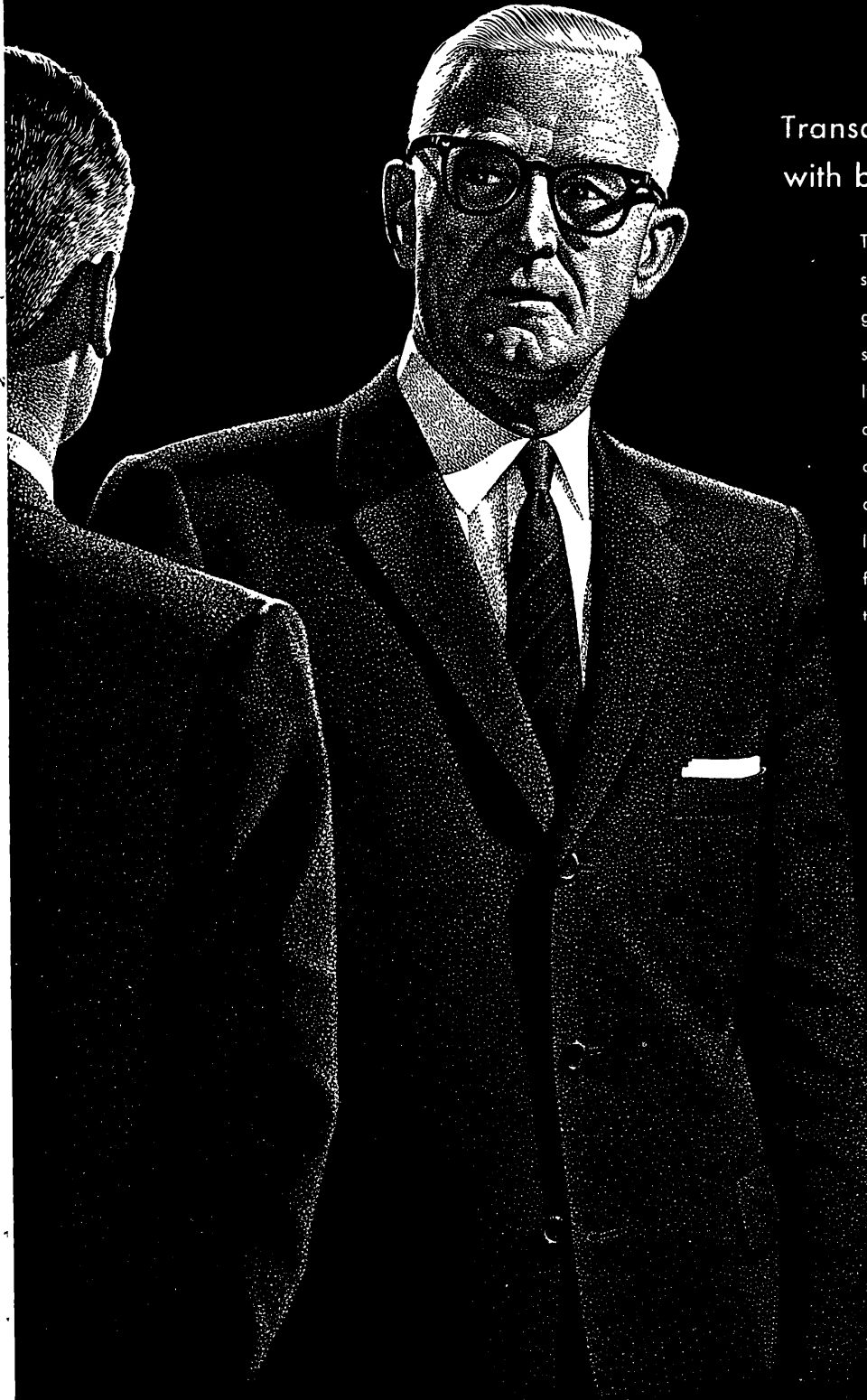

Transac S-2000 ... the system with built-in longevity

The Philco Transac S-2000 all-transistor data processing system will keep pace with your business today... and for generations to come. True asynchronous operation permits system updating and expansion without reprogramming. It performs with incredible speed, delivering 213,000 arithmetic calculations per second. Transac S-2000 also offers major savings in space, installation, operation and maintenance. If your company is ready for large scale data processing, look ahead to Transac... first in fully transistorized data processing... the computer that brings you the world of tomorrow today!



transac s-2000 by **PHILCO**

First in Transistorized Data Processing

GOVERNMENT AND INDUSTRIAL DIVISION • 4700 WISSAHICKON AVENUE PHILADELPHIA 44, PENNSYLVANIA

COMPUTERS

and AUTOMATION

DATA PROCESSING • CYBERNETICS • ROBOTS

Volume 8
Number 11

NOVEMBER, 1959

Established
September 1951

EDMUND C. BERKELEY *Editor*
H. JEFFERSON MILLS, JR. *Assistant Editor*
NEIL D. MACDONALD *Assistant Editor*

SERVICE AND SALES DIRECTOR

MILTON L. KAYE MURRAY Hill 2-4194
535 Fifth Ave. New York 17, N.Y.

CONTRIBUTING EDITORS

ANDREW D. BOOTH NED CHAPIN
JOHN W. CARR, III ALSTON S. HOUSEHOLDER

ADVISORY COMMITTEE

MORTON M. ASTRAHAN HOWARD T. ENGSTROM
GEORGE E. FORSYTHE RICHARD W. HAMMING
ALSTON S. HOUSEHOLDER HERBERT F. MITCHELL, JR.
SAMUEL B. WILLIAMS

ADVERTISING REPRESENTATIVES

Middle Atlantic States MILTON L. KAYE
535 Fifth Ave. New York 17, N.Y.
MURRAY Hill 2-4194

Washington 6, D.C. ROBERT CADEL
1519 Connecticut Ave. Columbia 5-9727

San Francisco 5 A. S. BABCOCK
605 Market St. YUkon 2-3954

Los Angeles 5 W. F. GREEN
439 S. Western Ave. DUnkirk 7-8135

Elsewhere THE PUBLISHER
Berkeley Enterprises, Inc.
815 Washington St., Newtonville 60, Mass.
DEcatur 2-5453 or 2-3928

FRONT COVER

A New Magnetic Device for Memory and Logic . . . 1, 9

ARTICLES

The Demand for College Training in Digital Computing, F. R. HARTMAN . . . 11
Research, Instrumentation, Automatic Analysis, and Response, A. V. ASTIN . . . 15
Some Computer Developments in Sweden, MORTIMER DATZ . . . 16
Automatic Searching of Chemical Literature . . . 24
Computers and Automation in the U.S.S.R., E. J. HAGA 26

READERS' AND EDITOR'S FORUM

"Operation Will be Controlled" from a Distance of About 230,000 Miles by a "Coordination and Computing Center on Earth" . . . 6
Call for Algorithms for an International Handbook for Automatic Computation, A. S. HOUSEHOLDER . . . 6
Calendar of Coming Events . . . 22

REFERENCE INFORMATION

Computer Applications: Missile Tracking, Full-Time Use 14
Survey of Recent Articles, M. M. BERLIN . . . 29
Who's Who in the Computer Field (Supplement) . . . 32
New Patents, R. R. SKOLNICK . . . 34

INDEX OF NOTICES

Advertising Index . . . 34
Back Copies . . . see Oct., page 39
Bulk Subscriptions . . . see Oct., page 39
Computer Directory and Buyers' Guide, 1959 . . . 31
Manuscripts . . . see August, page 28
Reference and Survey Information . . . see August, page 29
Statement of Ownership and Management . . . 22
Who's Who Entry Form . . . see August, page 32

COMPUTERS and AUTOMATION is published monthly at 815 Washington St., Newtonville 60, Mass., by Berkeley Enterprises, Inc. Printed in U.S.A.

SUBSCRIPTION RATES: (United States) \$5.50 for 1 year, \$10.50 for 2 years; (Canada) \$6.00 for 1 year, \$11.50 for 2 years; (Foreign) \$6.50 for 1 year, \$12.50 for 2 years.

Address all Editorial and Subscription Mail to Berkeley Enterprises, Inc., 815 Washington St., Newtonville 60, Mass.

ENTERED AS SECOND CLASS MATTER at the Post Office at Boston, Mass.

POSTMASTER: Please send all Forms 3579 to Berkeley Enterprises, Inc., 815 Washington St., Newtonville 60, Mass.

Copyright © 1959, by Berkeley Enterprises, Inc.

CHANGE OF ADDRESS: If your address changes, please send us both your new address and your old address (as it appears on the magazine address imprint), and allow three weeks for the change to be made.



Computer Programmers:

*Seen any new horizons
lately?*

Do you sometimes feel that you're adrift in a sea of sameness... that beyond your present horizon is another just like it? If so, it's important that you know what's going on in computer programming at System Development Corporation.

In addition to developing large computerized control systems for SAGE, SAC, and other important operations—SDC is engaged in a number of long-range research projects. They include: automatic coding and problem-oriented languages; development of a language to automate transition from one computer to another; study of the organization of large systems; investigation of computer design from a standpoint of programability rather than engineering; information retrieval and medical data processing.

POSITIONS NOW OPEN AT ALL LEVELS
(at Santa Monica, California and Lodi, New Jersey)

The extension of SDC's programming activities into new areas has created openings for Programmers at various levels of experience, including senior status. Please send your inquiry to Mr. E. A. Shaw, SDC, 2406 Colorado Avenue, Santa Monica, California.

.....
"Project CLIP—The Design of a Compiler and Language for Information Processing," a paper by Harvey Bratman of SDC's Data Processing Research staff, is available upon request. Send request to Mr. Bratman at SDC.
.....



**SYSTEM DEVELOPMENT
CORPORATION**

Santa Monica, California • Lodi, New Jersey

Readers' and Editor's Forum

"OPERATION WILL BE CONTROLLED" FROM A DISTANCE OF ABOUT 230,000 MILES BY A "COORDINATION AND COMPUTING CENTER ON EARTH"

Following is the text of the Soviet News Agency's announcement of the circum-lunar satellite launched on October 4, 1959:

Under the program of outer space exploration and preparation for interplanetary flights, a third cosmic rocket has been successfully launched in the Soviet Union on Oct. 4, 1959. The rocket carries on board an automatic interplanetary station.

The launching was effected by means of a multistage rocket. The last stage of the rocket after it attained the necessary speed put the automatic interplanetary station into the required orbit.

The orbit for the automatic interplanetary station will ensure the passage of the station near the moon and its flight around the moon.

The automatic interplanetary station will pass at a distance of about 10,000 kilometers from the moon and after flying around the moon will continue its movement to the area of the earth. The chosen orbit makes it possible to observe the station from the earth's northern hemisphere.

The last stage of the third Soviet cosmic rocket weighs 1,553 kilograms without fuel [3,323 pounds].

The automatic interplanetary station was installed on the last stage of the rocket. After orbiting the station was disengaged from the rocket. The last stage of the rocket is moving over an orbit closely approximating the orbit of the station. The automatic interplanetary station is designed for a broad range of scientific studies in outer space. The station carries scientific and radio equipment, also a system for automatic temperature control. The scientific and radio equipment is powered by solar batteries and chemical sources of electricity.

The station weighs a total of 278.5 kilograms [601 pounds].

Moreover, the last stage of the rocket carries measuring equipment with power sources weighing 156.5 kilograms [343 pounds]. Thus the aggregate payload amounts to 435 kilograms [958 pounds].

The scientific information and the results of the measurement of the parameters of the movement of the automatic interplanetary station will be transmitted by means of two radio transmitters operating on frequencies of 39.986 megacycles and 183.6 megacycles.

At the same time the 183.6 megacycles radioline will be used to control the elements of the orbit of the interplanetary station.

The signals of the transmitter operating on the frequency of 39.986 megacycles represent pulses of a duration varying from 0.28 of a second.

Information from the board of the automatic interplane-

tary station will be transmitted at definite intervals for two to four hours a day in conformity with the program of observations.

The operation of the equipment of the automatic interplanetary station will be controlled from a coordination and computing center on the earth.

The measurement of the rocket parameters is effected automatically by a measuring complex whose monitoring stations are situated at various points of the Soviet Union.

All radio stations of the Soviet Union will broadcast reports on the movement of the third cosmic rocket.

On Oct. 4 the radio technical equipment will start operating at 1 P.M. Moscow Time.

At that time the rocket will be over a point in the Indian Ocean 80 degrees Eastern longitude and 5 degrees Southern latitude at a distance of 108,000 kilometers from the earth.

The radio-technical equipment will operate for two hours.

Radio observations of the rocket can be conducted from the territory of Europe, Asia, Africa and Australia.

The launching of the third Soviet cosmic rocket and the development of an automatic interplanetary station will supply new data on outer space and represent another contribution of the Soviet people to international cooperation in outer space exploration.

CALL FOR ALGORITHMS FOR AN INTERNATIONAL HANDBOOK FOR AUTOMATIC COMPUTATION

Alston S. Householder

Oak Ridge National Laboratory
Oak Ridge, Tenn.

Preparation of a handbook for automatic computation, in five or more volumes, is now under way for publication by Springer-Verlag, Germany. It will appear in F. K. Schmidt's series, "Grundlehren der Mathematischen Wissenschaften." Editors are: F. L. Bauer, Mainz; A. S. Householder, Oak Ridge; F. W. J. Olver, Teddington; H. Rutishauser, Zurich; K. Samelson, Mainz; R. Sauer, Munich; and E. Stiefel, Zurich.

The purpose of the handbook is to provide a collection of tested algorithms for mathematical computations of all sorts. These include the solution of finite and of functional equations, methods of approximating functions, the evaluation of special functions, etc. These algorithms are to be written in the programming language Algol, and hence will be usable on any machine for which a suitable translator is available, and even without a translator can be used as a model for programming.

It is evident that such a collection could have no general utility unless written in some common descriptive language. The descriptive language will be English.

[Please turn to page 10]

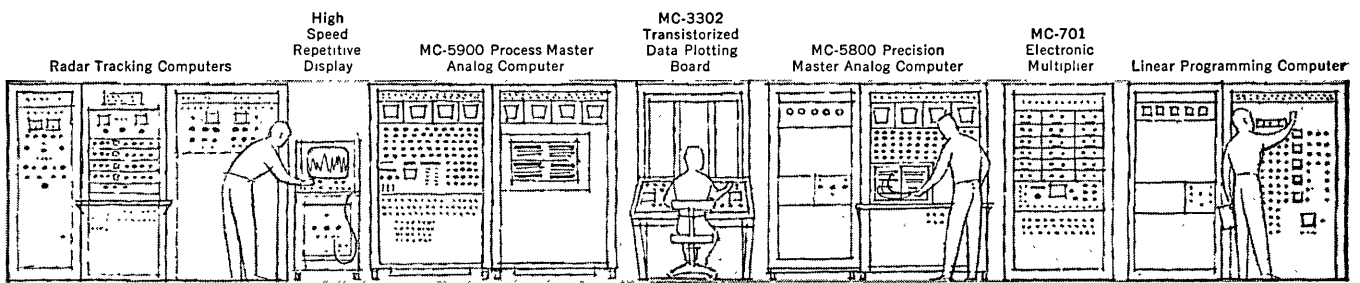

Some people can prove man and mouse are identical

It's all according to the points of similarity you choose. Differences are what really *prove* the superiority of man over mouse. Computers have differences, too. In fact, it's in these differences that the CSI-designed MC-5800 obsoletes every other Analog Computer. The best proof lies in

cold
hard
Specifications

- Exclusive dynamic memory makes automatic iterative solution of statistical or optimization problems a reality.
- Stable amplifier operation over the entire feed-back range from zero to infinity.
- Lowest amplifier grid-current $<10^{-9}$ ampere.
- Amplifiers provide lowest noise level output—less than one millivolt at unity gain.
- Amplifier frequency response—flat to 10,000 cps and only 3 db down at 28 kc.
- Real-time precision @ speeds to 60 solutions/sec.
- Exclusive electronic generators of the function of two-or-more variables may be programmed at patch-board in same time required for setup of single-variable generators.
- Will program 134 amplifiers, 30 electronic multipliers, 18 diode function generators, 2 time-delay generators, 8 relay amplifiers, and 6 servos from one 2128-hole patchboard.
- Highest performance electronic multiplier—flat to 10,000 cps and only 3 db down at 20 kc.
- Dynamic memory + high-speed quick-reset rep-op provide practical approach to solution of simultaneous partial differential equations.
- Dynamic memory with time-base accuracy of $\pm 10 \mu\text{sec}$ provides automatic parameter searching by iteration—an exclusive capability.
- Solution of problems with up to 15 amplifiers in closed loops.
- Plug-in dynamic components ease maintenance.
- Lowest computer cross-talk—rejection greater than 2,000 to 1.
- Selection of real-time, expanded-time or high-speed compressed-time without reprogramming.
- Passive networks stabilized at $< 1^\circ\text{C}$ above room ambient—no oven required.
- EVERY SPECIFICATION IS GUARANTEED TO BE TRUE PERFORMANCE STANDARD—IN SUSTAINED OPERATION.
- Only diode function generators utilizing resistors, potentiometers, and diodes of equal quality to those in computing networks.
- Only diode function generators with individual hi-lo gain positions for *each* segment.
- Lowest function generator drift $< 5 \text{ mv}/8 \text{ hrs}$.
- Lowest servo step-function overshoot—less than 1%.
- DC tachometer feedback on all servos.
- Complete control of all amplifiers, multipliers, dividers, and non-linear equipment at patchboard.
- Exclusive equipment-door packaging for free access and quick maintenance *without* shutdown.
- Insulated patchboard prevents costly shorting accidents.
- Power supplies eliminated from console—lowest, most stable operating temperatures—rise $< 3^\circ\text{C}$.
- Field expandable without mechanical rework or rewiring.

MAN IS A MOUSE



There are many more differences (over a hundred, in fact). Before you buy or lease your next analog computer, compare them all... and we think you'll agree with us when we say: The MC-5800 obsoletes every other analog computer made.

Computer Systems, Inc.—designers and manufacturers of the *highest* precision analog computers and computer accessories.



COMPUTER SYSTEMS, INC., 611 BROADWAY, NEW YORK 12, N. Y. • SP 7-4016
A Schlumberger Subsidiary • formerly Mid-Century Instrumatic Corp.

ROYAL PRECISION

LGP-30

**Your
greatest
computer
value
on
the
market...**

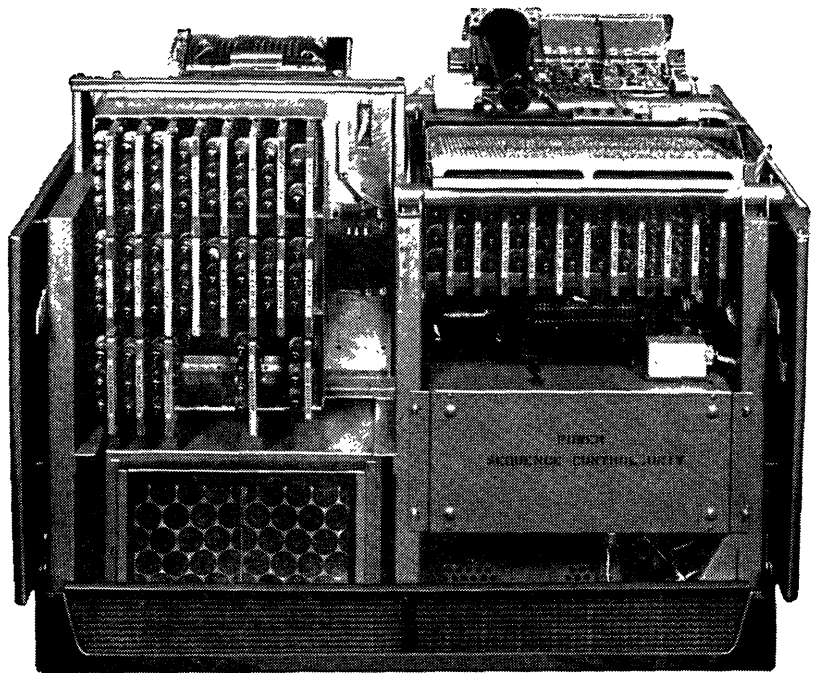

inside . . . The world's largest-selling engineering and scientific computer, the compact, mobile LGP-30 is also the lowest-priced complete computing system you can buy or lease. It gives you the largest memory (4096 words) and capacity in its class. Internal components have been greatly reduced to insure highest operating reliability. The logic circuit and few etched circuit cards are easily removed for checkout and maintenance. **and** . . . The LGP-30 operates from any wall outlet, requires no site preparation. With its simplified command structure, the LGP-30 is the easiest computer to program and operate. It is delivered complete with tape typewriter for alpha-numeric input-output. An extensive library of programs and sub-routines is available. Sold and serviced coast-to-coast, in Canada and abroad by Royal McBee, it's your greatest computer value inside and **out.**

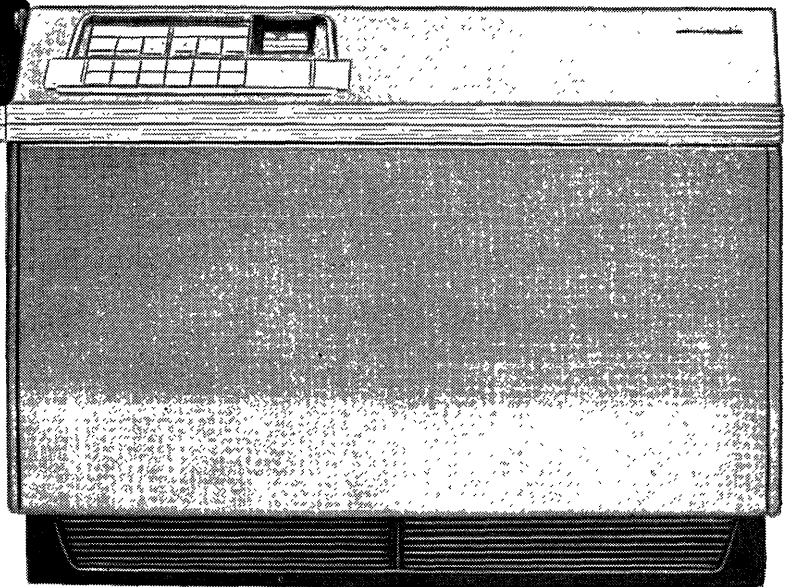
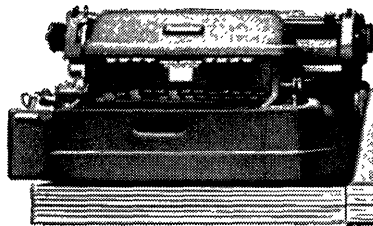

Royal Precision Corporation

Royal Precision is jointly owned by the Royal McBee and General Precision Equipment Corporations. LGP-30 sales and service are available coast-to-coast, in Canada and abroad through Royal McBee Data Processing offices. For complete information write **ROYAL MCBEE CORPORATION**, data processing division, Port Chester, New York



A New Magnetic Device for Memory and Logic

Aeronutronic
Newport Beach, Calif.

The front cover shows several hundred of tiny, ferrite, computer elements called Biax, compared for size with an ordinary nickel. The element can be used for both memory and logic circuits. It was developed by Aeronutronic, a Division of Ford Motor Co., Newport Beach, Calif., and is now in mass production. Complete memory systems and computers using the Biax element are currently being marketed for special commercial and military applications.

The Biax element is a small rectangular bar of ferrite magnetic material measuring 50 x 50 x 85 mils. The elements are so small that 310,000 will fit into a quart milk carton.

The basic concept employed by Biax is that of flux interference between orthogonal magnetic fields. This is accomplished by means of two 20-mil orthogonal holes through the element. The flux interference takes place in the magnetic material between the holes. Because of the orthogonality, no normal magnetic coupling occurs between conductors associated with the two holes in the materials.

By controlling the spacing between the holes, the flux interference techniques can be made either destructive or non-destructive. Memory applications employ the

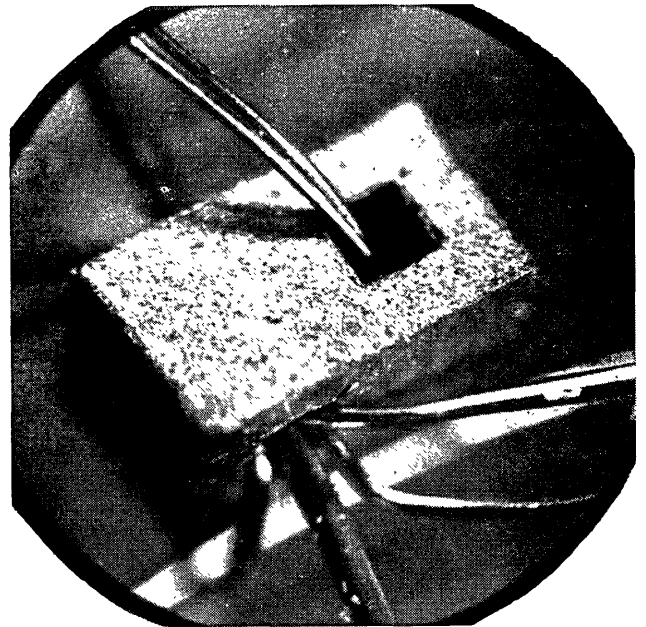

This enlarged microscopic photograph of a Biax memory element shows details of wiring in the tiny, new computer component developed by Aeronutronic.

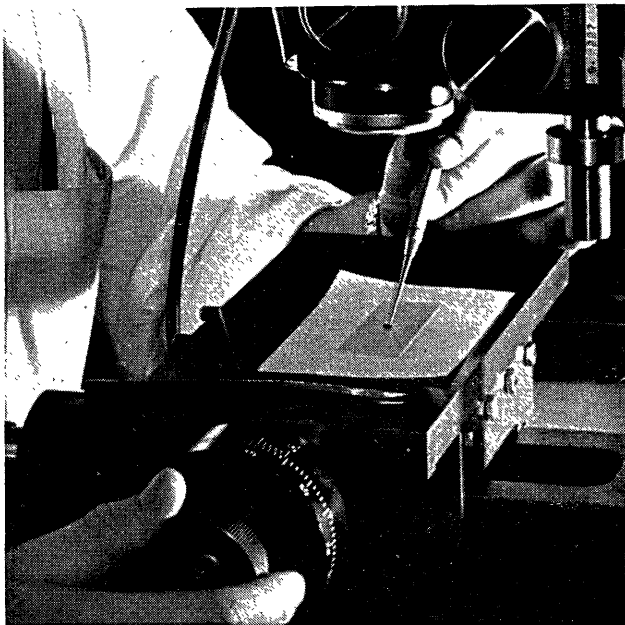

The relative size of a Biax element is shown here.

non-destructive element whereas logical circuitry makes use of the destructive element.

In the memory element, one of the orthogonal holes acts as the storage axis while the other hole acts as the nondestructive interrogate axis. In the logical element, the orthogonal holes are placed extremely close together.

The elements have been interrogated over one hundred billion times at a ten megacycle rate with no loss in output signal, indicating reliable non-destructive readout and low heating.

The memory element may also be operated under extreme environmental conditions. A memory array has been successfully operated for a number of hours at 260° F. and also at 0° F. Tests indicate that arrays can be fabricated which will operate in the vicinity of the Curie temperature of the ferrite used in their manufacture.

Typical logical elements for computers involve both gating elements and storage elements (flip-flops). Both types of logical elements have been successfully built and tested using Biax elements.

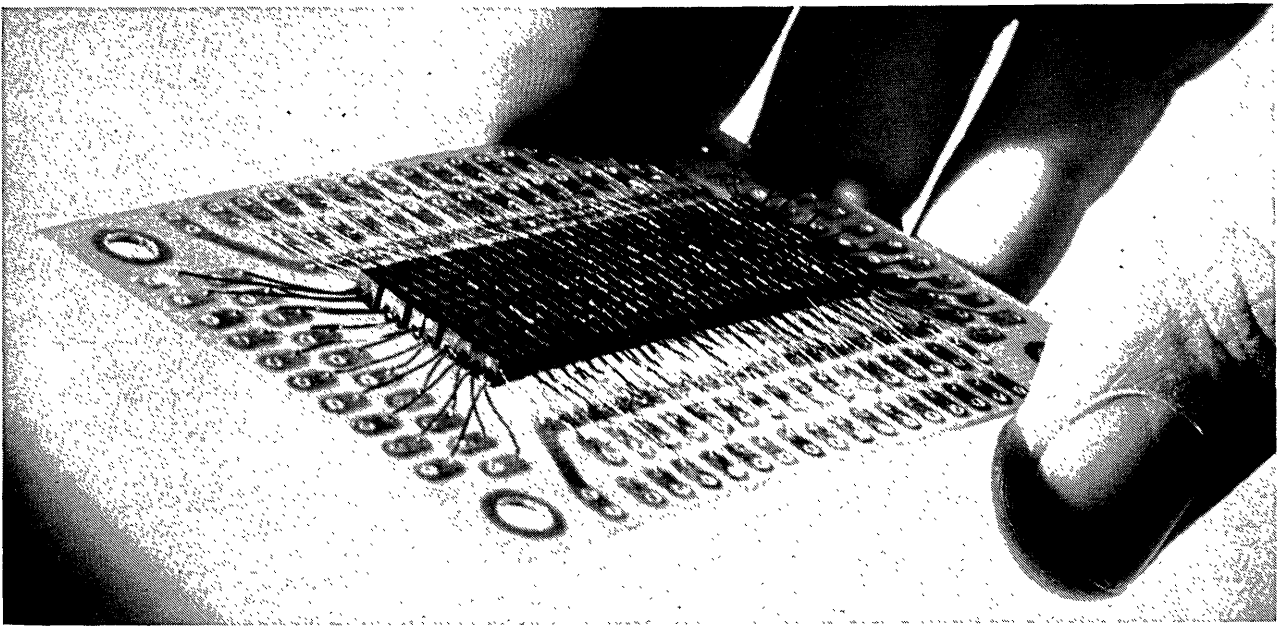

This is a typical Biax array for an electronic digital computer memory unit. The printed circuit card contains more than 300 Biax elements. Multiples of such printed circuit cards, containing Biax, are mounted adjacent to one another in a computer to provide large memory capacity.

High speed operation up to 20 megacycles of isolated elements has been achieved. Operational memory circuitry and logical circuitry have been operated at 2 megacycles.

When mass-produced, Biax computing equipment is considerably cheaper than much other current equipment. Present estimates indicate the cost saving in logical devices will be at least a factor of 10.

The new elements may be densely packed: 200 flip-flops and 3000 gates—the equivalent of 15,000 to 20,000 semiconductors—can be packed in 1/10 of a cubic foot.

The application of Biax techniques will reduce the number of solder connections in a typical computer by a

factor of 10 to 100, because many Biax elements may be linked by a single wire, thus avoiding the large number of solder joints necessary when semiconductor devices are used. The number of connectors will also be reduced by a factor ten or more.

Because of the smaller currents required to operate this type of memory, the total power required to achieve a given computational speed is materially reduced.

Biax techniques are currently being applied to a number of airborne and ground-based military projects where multi-megacycle data processing is required.

Readers' and Editor's Forum

[Continued from page 6]

As plans now stand, the organization of the series will be as follows: Volume 1a will contain a description of the use of Algol, and Volume 1b a description of the structure of translators. These introductory volumes are the only ones that will not be made up primarily of actual algorithms. Volume 2 will be devoted to the solution of finite equations, linear and nonlinear, including the determination of characteristic values and vectors of matrices. Volume 3 will be on functional equations, especially differential equations, ordinary and partial, and integral equations. Volume 4 is concerned with methods of approximation, and Volume 5 the evaluation of particular functions. It is possible that certain algorithms, such as those for solving inequalities, for mathematical programming, for statistical computations, and the like, that do not seem to fall naturally in any of these areas, may be reserved for a sixth volume. Each algorithm is to be accompanied by enough explanatory information to make it understandable, along with whatever information is available on speed, accuracy, range, or, more generally, for judging the effectiveness of the algorithm for a given type of problem. In any event, only pretested algorithms will be published.

Before the appearance of the volumes themselves, the al-

gorithms will be republished in a series of supplements to the journal, "Numerische Mathematik." This is partly to make each algorithm generally available at the earliest possible time. But in addition to this, such pre-publication makes it possible to include in the handbook itself additional information, and even corrections, that might come in from users.

Contributions are earnestly solicited. For the present, at least, these must necessarily be in the form of actual algorithms, along with information as to the extent and mode of testing the algorithm, estimates of accuracy, and experience in using it. Untested algorithms will not necessarily be rejected ipso facto, but their inclusion must necessarily await actual test. As algorithms are published, information relating to published algorithms also will be welcomed. Contributions may be sent to any of the editors named above.

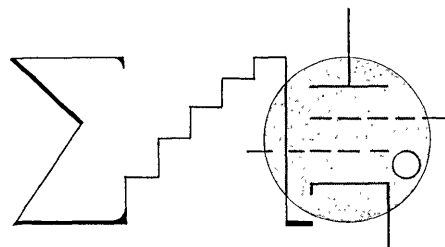

THE DEMAND FOR COLLEGE TRAINING IN DIGITAL COMPUTING

Frank R. Hartman
Pennsylvania State University
University Park, Pa.

The history of electronic digital computing is so recent that it can hardly be called history. Digital computing was born barely yesterday, and the picture resulting from its flourishing and phenomenal growth is of an infant of giant proportions. We need to make some plans for the child's future education, but the present major problem is an army of teachers.

To get some measurements on its own computer teaching problem, the Pennsylvania State University recently undertook to determine the extent to which computing facilities had become a necessity to (1) its research-minded faculty and (2) a stable part of the commercial and industrial environment into which the University could expect to send its graduates. The information reported here deals exclusively with the second portion of the Penn State study. The study seeks to ascertain how computing facilities are distributed in industry and to assess the resulting need for computer training of college graduates. The method of obtaining the information was a mail survey, based on the assumption that business, itself, could make the most accurate estimate of its own needs.

The Survey Method

The survey population was established as the group of commercial and industrial recruiters who regularly visit Pennsylvania State University to interview prospective graduates and who are listed with the University Placement Division. This population includes most of the nationally known firms that are of sufficient size to make use of a college-recruiting team, and also a selection of smaller firms that contact Penn State because of their nearness.

The questionnaire asked a commercial concern essentially three questions: (1) What is the nature of your present or contemplated computing facilities if any? (2) What is your present demand for graduates in a specific curriculum possessing various levels of computer knowledge and experience? (3) By what factor would you multiply your figures to estimate your computer usage and demand for computer-trained employees in 1970?

The questionnaire was sent to 640 industrial and commercial concerns, which can be reduced to an effective 600 because of overlap among the corporations. 325 replies were received, 54% of the number polled. An es-

timate for the remaining 46% was made by an arbitrary increase of the obtained figures by 25%.

It should be remarked that random sampling, whether of the original population or of the non-responding firms, would have constituted a more adequate sampling design. Unfortunately time and resources were not available to insure the close approximation to 100% return which such designs require. To make some estimate for the non-responding firms which constitute almost half of the original population it was argued that firms possessing a computing facility were much more likely to respond to the questionnaire than those which did not. The addition of 25% to extrapolate to the total population therefore seemed conservative and reasonable. Both the original and extrapolated results of the survey will be presented and the reader may choose for himself whether or not to accept the extrapolation.

The Survey Results

The distribution of computers by models in the 325 companies that responded is given in Table 1. 388 machines have been installed and 101 are contemplated or on order. 35 respondents indicated that their companies had computer facilities, several very extensive, but gave no details. Another 17 are seriously considering the installation of a computing facility, and 3 respondents report access to service bureaus. These additional categories are not included in Table 1.

Of the 325 firms replying to the questionnaire, 229 or 70% have computing facilities. If these figures are augmented by the 17 firms seriously considering new computing facilities, a total of 246 or 76% will be utilizing computer-oriented personnel. Adding 25% to this last figure and divided by 600 rather than 325, the estimated proportion of the total population of Penn State recruiters using computers is 51%.

The next part of the information derived from the survey relates to the demand by the Penn State recruiters for graduates with collegiate training in computers or computing. This information is predominantly supplied by the recruiters who had experience with a computing facility, although a number of firms who had considered the feasibility of such a facility also expressed their opinions.

In regard to college training there are several questions which are of interest: (1) In which curricula has

TABLE 1

FREQUENCY DISTRIBUTION OF COMPUTERS IN USE, CONTEMPLATED, OR ON ORDER,
AS REPORTED BY 325 RESPONDENTS AND EXTRAPOLATED

Type of Computer	No. in Use On the Basis of Received Replies (From 325 Respondents)	Estimated No. in Use in Total Population (600) Of Penn State Recruiters	No. Contemplated or On Order on The Basis of Received Replies	Estimated No. Con- templated or on Order In Total Population of Penn State Recruiters
IBM 602, 604 or 608	77	96	4	5
IBM 610	2	2	3	4
IBM 650	118	148	22	28
IBM 701	4	5	0	0
IBM 704	34	42	3	4
IBM 705	25	31	11	14
IBM 709	3	4	5	6
IBM 7070	1	1	25	31
IBM 7090	0	0	5	6
Univac 60	5	6	0	0
Univac 120	9	11	0	0
Univac I	10	13	0	0
Univac II	1	1	3	4
Univac 1102	3	4	0	0
Univac 1103	2	3	1	1
Univac 1105	0	0	1	1
Rem. Rand File Computer	8	10	1	1
Datatron 202	1	1	0	0
Datatron 205	15	19	1	1
Datatron 220	0	0	1	1
Datamatic 1000	1	1	1	1
Bendix G-15	14	17	6	8
Royal-McBee LGP-30	18	23	3	4
Burroughs E-101	32	40	1	1
RCA 501	0	0	3	4
Alwac III	2	3	0	0
LARC	0	0	1	1
Miscellaneous	3	4	0	1
Totals	388	485	101	126

a knowledge of computing become a critical factor in training? (2) What level of knowledge about computers is required? (3) What increase in the demand for computer training is likely in the next decade?

To obtain answers to these questions the respondents were asked to examine a list of approximately 30 curricula in which Penn State seniors are graduated and to consider what kind of computing training was desirable for a graduate in a particular curriculum. It was further requested that for each curriculum the number of persons previously hired who possessed a particular level of proficiency be specified and estimates be made of the probable number of vacancies in the following year.

Table 2 lists those Penn State curricula which received at least one mention as needing computer training for their graduates. For each curriculum, the following information is given: (1) the number of times the curriculum has been mentioned as requiring computer training of its graduates; (2) the number of times a particu-

lar proficiency level of training was mentioned for graduates of the curriculum; (3) the number of graduates in a curriculum of a particular proficiency level hired in 1958; the number of unfilled or inadequately filled positions for the coming year (1958-1959).

The proficiency levels for computer training (A, B, C, D and E) were defined, as follows:

- A. General acquaintance with electronic computers; their principles of operation, problems applicable, cost, general types of programs, etc.
- B. Knowledge of capabilities of computers relative to specific problems; preparation of these problems for programming; interpreting output directly with computers.
- C. Preparation of internally stored programs for scientific and data processing problems and experience in computer operation using these programs.
- D. Knowledge of mathematics (numerical methods, symbolic logic, etc.) necessary for advancing com-

puter applications, planning and development.

E. Background in the engineering problems associated with computers (maintenance, modification, design, etc.).

The most useful information concerning any given curriculum is the number of times it has been mentioned by the respondents as requiring computer training of its graduates and at what levels. The outstanding curricula are accounting and mathematics. Next in importance are physics, business administration, electrical, industrial and chemical engineering. In part, these figures reflect the relative number of graduates of a particular curriculum in the business and industrial world, but in general this is a reflection of the use to which business computing installations are currently being put. The most common application is bookkeeping and accounting; engineering design problems are a large but secondary common application. Mathematicians are a special case. They are a necessary intermediary between the problem and the machine and are in such short supply that some plan which will allocate many of their responsibilities to other personnel seems necessary if the application of computing to industrial and commercial problems is to proceed at reasonable speed.

It should be noted that the predominant level of proficiency specified is quite variable among the different curricula. In accounting and business administration the need seems to be for personnel who are familiar with computers and what they can do and perhaps formulate their problems in a logical order amenable to the skills of a programmer. Engineers with all levels of computing training are useful, although chemical engineering at present seems to require training of the same level as business and accounting. Mathematicians are, again, an exception. Their necessary training consists of those spe-

cial branches of mathematics that are particularly applicable to computing although, a thorough grounding in machine logic is an obviously necessary adjunct to their training. The desired proficiency level for the physics graduate is apparently either very high or very low; that is, he needs, either a nodding acquaintanceship or one that is comparable to that of the mathematician. This latter level of specification may simply reflect the prevailing close relation between physics and mathematics. Training in computer design is at present deemed to be almost entirely the prerogative of the electrical engineers.

Considering the totals over all curricula, the heavy demand is for training at a level of easy familiarity with computers but not of specialized sophistication.

The figures dealing with the vacancies to be filled by computer-trained college graduates and the number previously hired must be taken lightly. Graduates with proper training have not been available because of the recency of the entrance of the colleges into instruction in the computing field so that industry has not concentrated on their recruitment for the simple reason that there were none to be had. Secondly, the respondents themselves, were extremely loath to make such estimates, and in many cases refused to do so.

Thus, although it would be very desirable that we could estimate the demand for computer-trained personnel in solid figures representing vacant positions, the field has not yet reached such stable patterns of growth and planning as to make this possible.

However, this does not mean that no estimate can be made. The responding firms were asked to estimate the factor by which their figures could be multiplied to obtain estimates for 1970. The average of the estimates of this factor is 3.6.

TABLE 2

CURRICULAR BREAKDOWN OF FREQUENCIES OF POSITIONS REQUIRING COMPUTER TRAINING

Curriculum	No. of Times Curriculum Mentioned	No. of Times Specific Level of Computer Training Mentioned						No. Hired in 1958 by Levels of Computer Training					No. Unfilled or Filled Inadequately (1958-1959) by Levels of Computer Training						
		A	B	C	D	E	Total	A	B	C	D	E	Total	A	B	C	D	E	Total
Accounting	89	49	38	27	12	1	127	6	2	1	1		10	60	63	26	19		168
Aero. Engineering	15	7	4	2	6		19	3	1	3		7	33	3	2	2		40	
Agri. Economics	1		1				1												
Agri. Engineering	2		1			1	2										1		1
Bus. Administration	58	32	17	14	10		73	40	1	1	1	43	46	23	16	7		92	
Ceramic Technology	2		1	1	1		3												
Chem. Engineering	41	26	20	9	7	1	63	6	4		1	11	15	22	1	4		42	
Chemistry	22	14	6	4	2		26	8			1	9	21	1		2		24	
Civil Engineering	15	9	8	4	2		23		4			4	2	14	5	1		22	
Commerce	13	10	5	1			16	1				1	5	2				7	
Dairy Science	1																		
Economics	19	11	6	4	3		24						1	2		1		4	
Elec. Engineering	65	29	23	19	20	20	111	6	6	7	5	155	115	62	11	30	43	261	
Food Nutrition	1	1					1						3					3	
Fuel Technology	4	1	1	1	2		5												
Geology	3	3					3						2					2	
Geo. & Geo. Chemistry	7	3	2				5												
Ind. Engineering	39	20	15	17	7	1	60	6	1	1		8	4	21	13	5		43	
Mathematics	90	30	20	34	72	3	159	8	1	8	68	85	38	13	60	95		206	
Mech. Engineering	49	27	17	13	8	7	72	1	8	2	1	34	19	20	8	2		49	
Metallurgy	6	4	2	2			8						3		1			4	
Meteorology	5	1	3	3	1		8	4				4		9	3			12	
Pet.-Nat. Gas	10	9	4	1	2		16	1				1	8	1		2		11	
Physics	40	20	10	8	17	5	60		1	33	1	35	15	8	3	14		40	
Psych (Industrial)	8	6	3	2	1		12	3		1		4							
Liberal Arts	1	1					1												
Total	606	313	207	166	173	39	898	90	30	23	113	191	447	390	264	149	184	44	1031

A Look at the Future

For the year of 1970 it is estimated that there will be 4,641 vacancies or approximately 8 positions in each of the 600 companies. 2 of these positions will be for electrical engineers. It must be stressed that while precision can not be claimed for the extrapolations presented, the sources of error are predominantly distortions in the direction of underestimating.

It has been pointed out that many business concerns did not make estimates because of the size of their organization or because of a felt lack of experience with their computer facility, and that others indicated their preference for in-service computer training either at the computing facility or on the premises of the manufacturer.

The preference for in-service computer training is probably based on the nonexistence of adequate numbers of computer-trained college graduates, and the general success of open-shop policies at the computing facilities. However, there are several objections to the assumption of the adequacy of in-service training for 1970.

First, the colleges are probably now in position to assume a responsibility for computer education for which they were previously not ready.

Second, in regard to research applications, there has

been an immense and continuing adaptation of quantitative data-handling techniques to all of the basic and applied fields of knowledge since the end of World War II. These quantitative methods have not as yet nearly reached the saturation possible in these various fields of knowledge. Therefore, there may be expected to provide a continually expanding impetus to data processing in the next decade. At the same time, digital computing has only touched a fraction of the data processing areas to which it is applicable, and the natural expansion of these applications should accelerate the use of computers at least over the next ten years. This expansion will have an effect which is two fold, a demand for the computation specialist and the creation of a generation of students for whom computing facilities are as familiar as slide rules. Under such conditions it is not probable that in-service training will prove adequate as the primary source of computer instruction.

One fact seems certain. The colleges and universities are going to require many of their students to take considerable computer training in the future. It is the responsibility of commerce and industry, as the most interested parties among the public served by these educational institutions, to make known their considered opinions as to the form which this training should take.

COMPUTER APPLICATIONS

MISSILE TRACKING

During every rocket launching at Cape Canaveral an ultra-high speed IBM 709 electronic digital computer — fed by radar sightings or radio measurements — begins to monitor, compute and predict the flight of the rocket. With pin point accuracy the 709 begins pouring out predictions *in real time* at the rate of 10 per second forecasting for the Air Force Range Safety Officer the point where the rocket will fall either at burnout or from some malfunction.

At Canaveral's central control the RSO has a plotting board with a map overlay on which he can view the 709's predictions and watch the rocket's flight at all times from take-off to point of impact.

If the RSO watching the computer's predictions from central control sees that the vehicle is heading out of pre-determined safety boundaries, he can destroy the rocket in the air before any harm can be done. The IBM 709 is able to digest in a fraction of a second all the forces acting on a newly launched rocket and from them predict its trajectory; and this ability gives United States rocketry a much desired margin of safety.

In the case of the Vanguard rocket, for example, the 709 performs an additional important function. While the rocket is coasting up to the altitude where it will fire its last stage driving its satellite to a horizontal speed sufficient to put it into orbit, the Cape Canaveral IBM 709 transmits preliminary data on the rocket's position and velocity to the IBM 704 at the Vanguard Computing Center in Washington, D.C. There the Van-

guard Center's IBM 704 combines the coasting information with data on the expected performance of the rocket's last stage. From these it produces the first computations of whether the satellite has a chance of orbiting, and if so, what the orbit will look like. These calculations are coming from the IBM 704 within minutes after launching the satellite — just after the rocket's third stage has burned itself out high over the Atlantic Ocean.

FULL-TIME USE

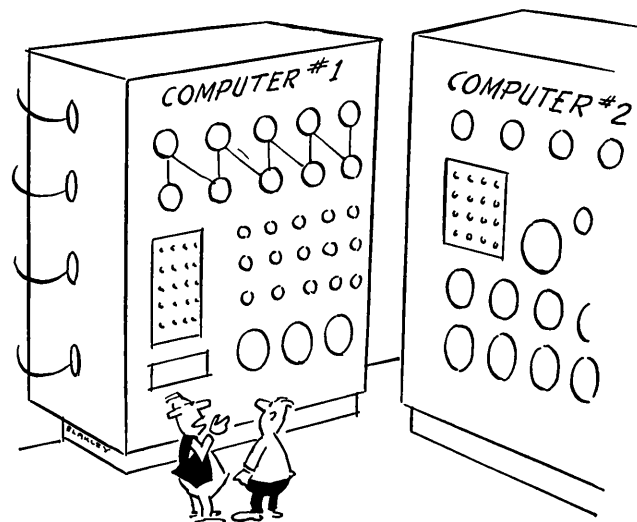

"This one thinks up the questions for the other to answer."

Research, Instrumentation, Automatic Analysis, and Response

Allen V. Astin
National Bureau of Standards
Washington, D.C.

(Based on a talk Sept. 18, 1959, at the Research and Development Center of
Leeds & Northrup Co., Pennsylvania)

Scientific instrumentation has a profound effect upon technical advancement and discovery. It is sometimes not fully appreciated that each advance or refinement in instrument manufacture brings with it important benefits to industry and thereby to society. Similarly, we often underestimate the role of instrumentation as a part of the general process of scientific research.

Instrumentation has become a recognized branch of science and technology. This is not merely because of the vastly increased number of instruments and their multiplied applications in science, industry and military technology, but because of underlying and unifying relationships. In other words, instrumentation is more than just a totality of measuring instruments. It involves: systems and methods of use; the theory of response characteristics of physical systems; the theoretical and practical study of the generation and handling of signals; the concept of feedback; automatic analysis and control; automatic data processing; and other functions. In broad and general terms, instrumentation is the science and art of providing devices and techniques for physical measurements and for processing the results thereof.

Instrumentation, Observation, and Experiment

Instrumentation is clearly fundamental to the process of physical measurement, and hence to observation and experimentation. But observation and experimentation in science often start a cycle of further observation and experimentation. Dr. James B. Conant has pointed out that science differs from other progressive activities of man "to the extent that new concepts arise from experiments and observations, and the new concepts in turn lead to further experiments and observations." This regenerative nature of scientific research revolves around continual refinement and extension of the methods and devices for experimenting and observing. An instrument possessing increased accuracy, or a new method of using an instrument so as to reduce systematic errors, can give rise to new concepts. Likewise, completely new instruments or instrument techniques can generate revolutionary concepts. In turn, the new concepts continually create demands for new or improved instruments and techniques. The process is reciprocal and energizing. Thus scientific advancement and instrument progress are linked.

Still another way of appreciating the underlying force of instrumentation is to consider that instruments generate the information which is ultimately communicated from one laboratory to another, from one scientist to another,

and from research and development to production. Carefully calibrated instruments, compared through well-defined chains to national and international standards, make it possible for all scientists to express their results with common meaning in the universal language of measurement and numbers.

Communication

To pursue this communicative aspect a little further, I believe that many of us pass over the critical role which instrumentation carries in bridging the so-called gaps between research and technology. Devices for measurement have a persevering way about them of serving many disciplines and of disregarding sophisticated distinctions created between research and technology. Instrumentation is the common denominator.

Consider, for example, the current emphasis on electronic instrumentation. Because of the great versatility and increased sensitivity of electronic recording and control instruments, they have been applied to a variety of experimental problems, process testing, and control of production. Electronic instruments have come to be of service both in experimental laboratories where careful observation and adjustment are necessary and also in industrial plants where continuous observation and control are important. Electronic instrumentation clearly demonstrates the closeness of research and technology.

For another example, one which demonstrates how technology may turn about and have a significant effect on research, the demands of the radio and television industry have resulted in the making available of a variety of components which are indispensable to the instrument industry and to research. Radar developments made possible the scientific field of microwave spectroscopy. Telemetry is the basic instrumentation technique around which space and satellite research is built.

Automation

This brings us to the modern importance and application of electronic instrumentation, to automation. I believe the bright prospects for automating various industrial processes are a direct result of the phenomenal advances in the field of electronics which have been made in the past thirty years. Improved and simple sensing devices have now come into being which make it most practical to incorporate them into factory production. These electronic instruments also bring the exciting possibility of

the full use of "feedback" as a practical principle in automatic control. Feedback, as now conceived, is a modern extension of the notion of communication — communication between man and machine, and, as some might say, between machine and machine. Electronic devices are becoming message centers, analytic centers, and control centers of production. Through these devices, a physical measurement can be made, communicated, analyzed, computed, compared to standards, and then transmitted to alter or control an operation at another stage in the production process.

Two examples will partially describe how feedback can serve the cause of automating industry. The first example may be found in petroleum production where measurement, refinement, and processing control and modification are accomplished automatically with electronic instruments. Think of crude oil flowing through the cracking plant with instruments gauging and controlling the refining process. This is truly a technological advance. Similarly, in the milling of flour we find one of the oldest examples of automatic controls used to measure and modify a product while in process. Today's version of milling makes extensive use of electronic instruments.

Delegation of Decisions

Automation is more than the substitution of machine power for muscle power. It carries with it the profound notion that man may delegate to machines certain limited types of decisions, including the technique of continuous sampling by sensing devices. This promises to provide the flexibility to change any or all phases of a process as a result of machine analysis and control. Eventually we will find that automatic electronic devices will link production and marketing. There are today a number of examples

in which automatic electronic data-processing equipment ties plant production to the problems of marketing and management. Unfortunately these examples are as much characteristic of small and halting advances as they are of substantial progress. The road to automation is not automatic. It will take considerable scientific effort.

Automatic devices in industry are apparently coming into increasing use. To the extent that this is true this is good for technology. But automation, it must be remembered, is still in its infancy. There is still a great deal of instrumentation research, development, and application which has to be done. We still have a long way to go before we will have completely integrated and automated industry. We still need considerable understanding of the communication systems between devices. There is still a large philosophical problem to be worked out. We must come to a better understanding of how the high-speed arbitrary world of machines can logically deal with the real world of production and marketing. We must link technology to communications theory through advanced control instruments.

Summary

Instrumentation is a really important factor in technological research. First, instrumentation is the key to all experimental research. Second, it provides a cardinal important link between research and technology. Third, it can be the basis for business and technological growth. Fourth, it can be important to the future of both big and little business. And fifth, quality instrument manufacturers in the United States have a record of doing much to strengthen this nation's instrumentation capability and to advance our technical potential.

Some Computer Developments In Sweden

Mortimer Datz

International Institute of Meteorology
Stockholm, Sweden

Swedish Board for Computing Machinery

THE major impetus in the fields of computer design and application both here in Sweden as well as throughout the rest of Scandinavia has come from the Swedish Board for Computing Machinery (Matematikmaskinnämnden or MMN). The organization dates back to the early part of 1949. Industry and government had found the increase in business and scientific problems associated with a growing economy becoming burdensome when handled in the time honored way. The need for more efficient methods was recognized. An intensive survey was made and automation appeared to be the most promising solution to the vexing problem.

The Swedish State thereupon appointed a panel of experts, i.e. the MMN, to conduct a feasibility study into the matter of design and construction of a general purpose digital computer. A thorough investigation indicated the need to implement their findings and it was through this that the Board's Working Group was established (Matematikmaskinnämnden Arbetsgrupp or MNA).

Binary Automatic Relay Calculator

The experience gained through the pioneer work done in England (e.g. EDSAC, MUDCM) and the United States (e.g. EDVAC, BINAC, MARK III) served the group well. This together with the Board's own pro-

new improved "Memo-Scope"[®] oscilloscope

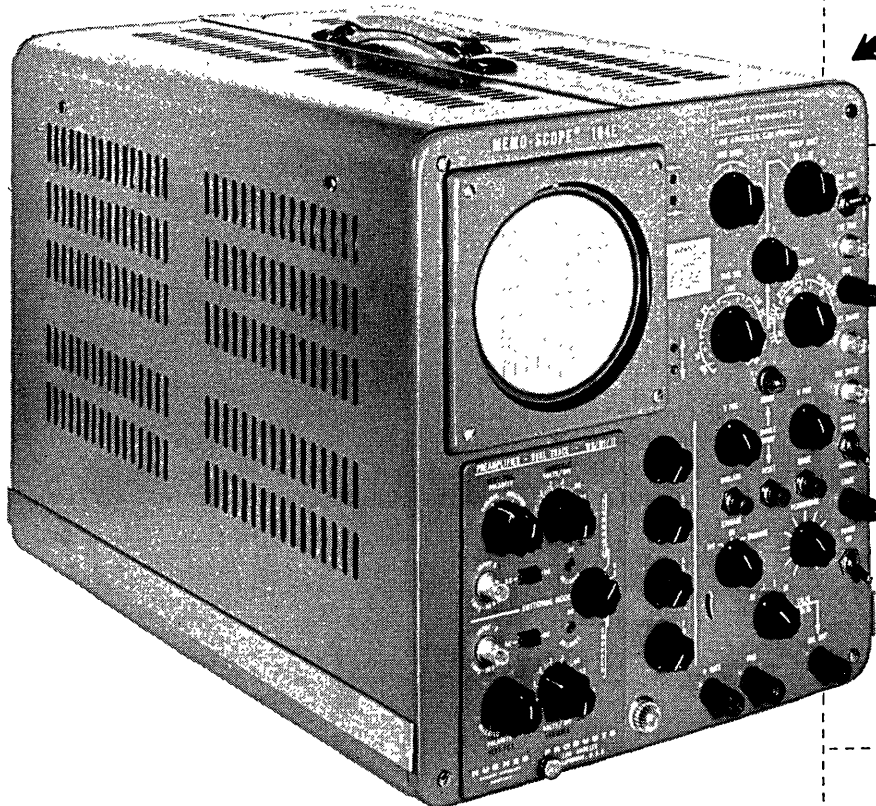

Still using "old-fashioned" methods for measuring non-recurring transients? If so, now is the time to investigate the easy way to solve your most difficult transient measurement problems with the latest model Hughes "Memo-Scope" oscilloscope.

Why? Because *new* features, *new* advanced circuitry, *new* panel layout and *new* mechanical design now assure maximum accuracy in all your transient measurements—*plus* higher performance, greater dependability and easier operation!



The Hughes "Memo-Scope" oscilloscope (Model 104E) stores nonrepetitive events for an indefinite period—hours, or days—keeping them available for thorough study until intentionally erased.

new improved features

- Simplified panel layout, redesigned trigger circuit...assure easier operation,
- Advanced mechanical design gives:
 - Better cooling for longer component life,
 - Far greater accessibility for maintenance,
 - Increased ruggedness; resistance to vibration,
- Built-in single-sweep circuit ("1-shot" trigger) at no extra cost,
- Available for either 110 v. or 220 v. operation.

applications

- Data reduction equipment troubleshooting
- Physical testing; shock, stress, strain
- Ultrasonic flaw detection
- Semiconductor testing
- Ballistics and explosives research ...and many others.

INDUSTRIAL SYSTEMS DIVISION

HUGHES PRODUCTS

*For complete information on the new improved Hughes "Memo-Scope" oscilloscope (Model 104E), detailed data sheets and application analysis of your transient measurement problems, write or wire: HUGHES PRODUCTS
Industrial Systems Division, International Airport Station, Los Angeles 45, California*

© 1959, HUGHES AIRCRAFT COMPANY

gram of research culminated in the machine known as BARK (Binar Automatisk Relä-Kalkylator). The actual construction was handled by the Board's technical staff in its own machine shop and electronics laboratory. The BARK was installed on February 1, 1950. The preliminary checkout extended through March 31 and served not only to train the operating personnel but also to disclose several points at which improvements could profitably be applied. These were successfully incorporated prior to the start of its operational schedule.

This machine had a total of some 5200 relays with an electrostatic memory of 90 data words (32 bits/word = 7 decimal digits and an exponent) together with 8 registers of 6 binary digits each. Summarizing some average speeds for complete (i.e., with access times included) arithmetic operations, one had an addition or subtraction in 120 ms, a multiplication in 160 ms, and a transfer in 80 ms.

Input-output was accomplished through use of a five channel perforated paper tape. The tape could move in but a single direction. It was, however, possible to punch the tape in one place and read simultaneously somewhat farther on using an input-output buffer storage. Punching of a single data word in the binary notation took approximately 1.3 seconds with the corresponding inreading of somewhat shorter duration. Output could be in either octal, binary, and/or decimal, though input was confined to binary and/or decimal words. Translation from the binary to its decimal equivalent or vice versa was not a built in feature of the BARK and thereby required use of subroutines. A single data word could be put into the specified form in about 2 or 3 seconds including reading or punching.

In general, a computation required wiring a plug board prior to its actual running. If the job was to be rerun at some later date, the board had to be wired anew. Though this was an obvious drawback the extensive list of 1200 instructions, permitted the simultaneous set up of three or four different problems. Efficient operation was based on this and in practice very little time was actually lost.

The display panel with its indicator lights, switches, and meters of one sort and another provided a means whereby the operator could follow the progress of the computation. The console's keyboard gave access to any cell within the electrostatic memory. Corrections and/or changes could therefore be keyed in so that one could, at least temporarily, avoid a rewiring job.

Problems Handled

During the following years the BARK most certainly justified the Board's optimistic expectations. The machine's normal operating efficiency stood above the 65% mark. At this time such reliability was noteworthy.

The MNA programming group has handled problems of wide diversity for governmental agencies, research institutions, and private concerns. In addition, they provide trained personnel to all who are interested in obtaining information on the possible application of computer techniques to their own particular needs. This service has illustrated in a most forceful manner what a computer can do and how its proper utilization results in a more efficient operation. A fuller

understanding of these potentialities has led to ever-widening acceptance in business and scientific circles.

Binary Electronic Calculator

Developments within the field of computer technology both here and abroad continued at an accelerated pace. By the fall of 1950 so many important advances had been made that the Board felt it imperative to consider design of a machine embodying these latest principles. Just prior to the close of 1950 a research and development project was set up to work out the plan in detail. It was decided that the fast memory would be of the Williams' type supplemented by a slower magnetic drum storage. The advantages of parallel operation had become clear and so was to be exploited to its fullest. The machine was to be known as BESK (Binar Elektronisk Siffer-Kalkylator). Like BARK its design and construction were handled directly by the Board's technical facilities. BESK was put into operation in December of 1953. At that time it was prophesied that a machine so fast as BESK would solve all the numerical work in Sweden in a matter of two weeks. This has been proven quite incorrect due primarily to the fact that the balance between experimental and intuitive methods on the one hand and numerical calculations on the other did entirely change when it became possible to execute large computations both rapidly and economically. The advent of the digital computer soon necessitated organizational changes in some fields, e.g., the aircraft industry and the meteorological services, though in others interest has fallen below expectations due mainly to difficulty in introducing new methods in some quarters. By 1955 the superiority of BESK over the BARK was so firmly established that few of the customers found it worthwhile to put their jobs on the latter. BESK'S already crowded work schedule was made even more so. This together with the urgent need of space led the Board to dismantle the BARK in October, 1955.

Initially, BESK was equipped with a 512 word (40 bits/word) CRT memory and a magnetic drum unit having but a single drum with a 4096 word capacity. However, during August and September of 1956 a number of important modifications and improvements were incorporated into its design. The electrostatic storage was replaced by a ferrite core having a 1024 word capacity. Though this promoted greater efficiency the machine speed was not increased. An addition, subtraction, or transfer took 56 us, a multiplication 364 us, and a division 700 us. Later, however, the microorder scheme for the whole of the instruction list was revised so that 14 us were cut from the basic operations. An addition, subtraction, or transfer now take 42 us, a multiplication 273 us, and a division 525 us. A further increase has been planned through raising the basic clock pulse frequency which as it stands is rated at 143 kilocycles. The magnetic drum unit was doubled; there are now two physical drums each of which has 128 32 word (40 bits/word) data bands. Corresponding to each of these channels is a ferrite-core reading head arranged in such a manner as to permit transfer of a block of information between the drum and the core, or vice versa via the arithmetic unit, in twenty to forty milliseconds. The block is normally the whole track, i.e. 32 words, though



Invites

COMPUTER PROGRAMMERS

*To Join Its Expanding
Scientific Community*

MITRE is a non-profit organization formed under the sponsorship of the Massachusetts Institute of Technology. Its nucleus is a Technical Staff of scientists and engineers with established reputations in the design and development of computer-based systems.

The organization's task is to provide the technical solutions to problems in the design, development and integration of large-scale, real-time control air defense systems. Ranging in scope from the practical problems of improving present systems through the design of future systems, MITRE assignments provide a unique multi-discipline environment in which significant contributions can be made.

System-oriented programmers with experience on large-scale computers will find opportunities to define problems and formulate solutions in:

- REAL TIME SIMULATION
- SYSTEM PROGRAMMING
- MATHEMATICAL MODEL MANIPULATION
- COMPUTER APPLICATIONS
- MACHINE DESIGN
- INFORMATION STORAGE and RETRIEVAL
- CODING TECHNIQUES
- SUBSYSTEM SIMULATION
- AUTOMATIC PROGRAMMING RESEARCH

These positions are available at MITRE's modern facilities in suburban Boston, Massachusetts, Fort Walton Beach, Florida, and Montgomery, Alabama.

To arrange an immediate confidential interview,
please direct your inquiry to:
Dana N. Burdette, Personnel Director

THE MITRE CORPORATION
244 WOOD STREET — LEXINGTON 73, MASSACHUSETTS

A brochure more fully describing MITRE and its activities is available on request.

it is possible, through manual adjustment prior to running the computation, to use blocks of 16 or even 8 words. However, such a procedure reduces the capacity of the entire drum by one half or one quarter, respectively, since it is not possible to store more than a single block on a track.

The drums rotate at about 3000 rpm. They, like the tape reader and the electric typewriter, operate asynchronously with respect to the remainder of the machine; the clock pulse generator is disconnected by means of an electronic switch, and the corresponding unit in the external device is connected. Upon completion of this type operation the unit in question sends a clearing signal to the control unit, after which the internal clock pulse generator is reconnected.

Though a BESK word is of 40 binary digits an instruction has but 20 bits, i.e. 8 for the operation and 12 for the address. The half cells are hexidically addressed from 0 through 7FF where counting according to the hexadecimal system runs in the following manner: 0,1,2, . . . ,9,A,B,C,D,E,F,10, . . . , 19,1A,1B, . . . , 1F,20, It is to be noted that a left half cell has an even address and the complementary right half cell the succeeding odd address. The 256 tracks of drum storage are hexidically addressed 0,2,4, . . . , 1FE.

The operation list in which there are some 75 instructions has been prepared in such a way as to distinguish between half cell and whole cell data words. This allows the programmer to adjust the accuracy of the computation to the needs of the customer and the size of the problem.

Library of Programs

During these years an extensive library of subroutines and standard programs has been developed for the BESK user. These may be broken down into the following categories.

1. Complete programs solving well defined standard problems. These include such jobs as curve fitting, solution of linear systems, extraction of roots from algebraic equations, time series analysis, eigen-value and eigen-vector problems, geodetic programs that make an almost complete data processing from measured values to final results, calculation of optimal forest road nets, adaptation of trees to logs and pulp wood, etc.: OVER 20 PROGRAMS

2. Automatic coding systems by which the coding may be simplified at the expense of efficient utilization of the machine's speed and capacity. There are a wide variety of interpretive procedures involving combinations of floating arithmetic, double precision, complex numbers, matrix calculations, etc. In addition, there is a compiler routine that allows one to program in terms of symbolic addresses and a pseudo code more nearly related to the mathematical language of the problems themselves. — 8 SYSTEMS

3. Routines for input of code. It is to be remembered that the program is written in hexadecimal terms. — 3 MAJOR ROUTINES

4. Input of decimal data: — 4 MAJOR ROUTINES

5. Printing (punching) of numbers in decimal form: — 9 MAJOR ROUTINES

6. Elementary functions: — OVER 15 ROUTINES

7. Special programs. This category includes such

diversities as debugging routines, various methods of integration and interpolation, solution of non-linear systems, eigen-values and eigen-vectors of symmetric matrices, calculations involving high order matrices, etc.: — OVER 24 ROUTINES

Data and instructions are fed in via the arithmetic unit to the core by means of a transistorized dielectric tape reader. The perforated paper tape is read at a maximum speed of 400 five position symbols per second. Four of these positions are relaying computational or typographical information while the fifth indicates whether or not this information is to be read into storage. It is to be noted that typographic data relates only to the input tape format, e.g., carriage return or space, and as such is not stored in the machine.

The control desk was connected to BESK in January of 1955. It has various switches whose settings determine where and when the machine starts and stops, the mode of operation (e.g., code check, computation rate), and the manner of output (e.g., punch, printer). In addition, there are indicator lights which permit examination of the accumulator, multiplier-quotient, instruction counter, storage register, and the operation register. Panel keys allow the operator to modify and/or display information from any specified location within the core.

Spotting Errors by the Sound Rhythm

There is also an interesting audio hookup to one of the registers in the arithmetic circuit. It allows one to hear the rhythm of the computation. The experienced programmer may oftentimes spot an error by ear. This feature serves as a useful adjunct to the checkout procedure.

The console is also provided with an output device known as a function writer. In this unit, special short words of 9 binary digits are converted to their analog counterpart and displayed in the form of spots on the face of a cathode ray tube. A camera using Polaroid film may be attached so that a permanent record of the graphical information is available. The stored program controls the operation of the function writer.

The off-line equipment, insofar as the outside programmer is concerned, consists of 4 punching-copying devices and a card-to-paper-tape converter. The punching-copying apparatus has two major components, the paper tape punch & reperforating unit and a modified IBM electric typewriter. Though cards are rarely used, the MNA does have a card-to-tape apparatus. An IBM printing card punch, type 26, has been rebuilt so as to include a tape punch. This then may be connected to an electric typewriter so that an outprint is also obtained.

Remote Use of the Machine

For the convenience of more distant customers the Board has joined the Telex network. This enables a programmer at some remote point to punch up a program, its input, and appropriate running instructions in the special Telex code. One then dials the BESK number (NOTE: the Telex system permits transmissions to any of the network members through a dialing procedure directly analogous to the type employed by the telephone system), and puts the alphanumeric paper tape

$$\mathbf{v} = \dot{u}\mathbf{u}_1 + \dot{v}\mathbf{v}_1 + \dot{w}\mathbf{w}_1$$

$$\delta = \frac{2\pi\lambda}{\omega_1}$$

$$m\ddot{x} + f\dot{x} + kx = Fe^{i\omega t}$$

$$m_t = K_2 m_q$$

$$r = \frac{T_{aw} - T_b}{u_b^2 / 2g_c J c_p} = \text{Pr}^{1/2}$$

$$v_c = \sqrt{\frac{2g_c \gamma P_c}{\gamma - 1 \rho_{t0}}}$$

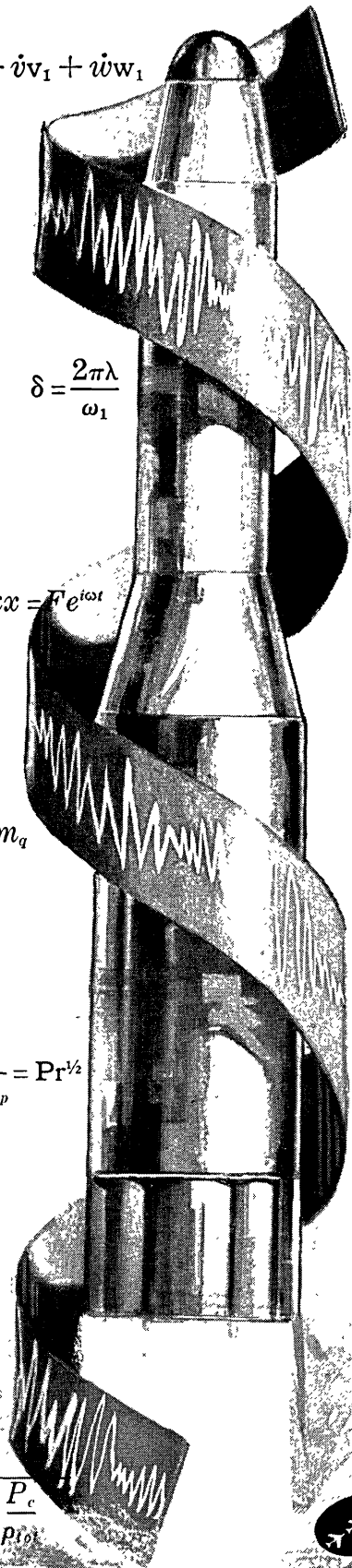

*Applied Mathematicians
Engineering Programmer Analysts
Programming Techniques Specialists
Data Processing Programmer Analysts*

Republic Aviation's newly organized Computer Division, centralizes in one group all company-wide computer activities related both to diversified Aero-Space R & D programs and Management Data Processing Applications. It provides unusual opportunities to...

ADVANCE COMPUTER APPLICATIONS TECHNIQUES CONCEPTUALLY AND IN PRACTICE

The outputs of the largest, fastest, most advanced computers are no "wiser" than the inputs devised by creative analysts and scientists. This fact is never lost sight of by the technical leaders of Republic's new Computer Division. Sustained effort is directed toward the goal of developing new mathematical and programming techniques to extend the state of the art in large scale computer applications.

Programs in which the Division participates include:

Research & Development

- Interplanetary Trajectory Studies
- Computer Simulation Investigation
- Plasma Propulsion Studies
- Space Environment Investigations
- Nuclear Studies

Management Projects

- Inventory Control
- Payroll Applications
- Drawing Control
- Operations Analysis

To implement these programs, an IBM 704 is now in operation and a 7090 is scheduled for installation in the near future. Other sophisticated data processing tools are available.

Immediate openings in:

APPLIED MATHEMATICS • PROGRAMMING TECHNIQUES
ENGINEERING-SCIENTIFIC PROGRAMMING ANALYSIS
DATA PROCESSING PROGRAMMING ANALYSIS

QUALIFICATIONS: BS, MS or PhD in Engineering, Physics, Mathematics, Statistics or Business Administration. 2 years experience in computer field desired.

Send resume in confidence to: Mr. George R. Hickman
Technical Employment Manager Dept. 26L



REPUBLIC AVIATION

Farmingdale, Long Island, New York

on the telesender for transmission to the machine. Upon receipt a telex program and input tape is punched. Special translation facilities are available which convert the material to machine code. The program itself has among its routines an output procedure to convert machine results to telecode. This then is retransmitted to the station of origin. The setup has proved to be highly successful.

Operation Schedule

The BESK is now being run about 129 hours per week, i.e. beginning at 0800 Monday through 1700 on Saturday. The classification of time generally includes 30 hours of scheduled preventive maintenance and technical experiments while 14 hours are on the average lost due to computational errors on uncertainties (including reruns).

Classification of Problems

I have in front of me a detailed statistical summary for the period March 1, 1954 through September 30, 1955. This reveals that of the 3796 hours effective computing time, meteorology (including numerical weather forecasts) accounted for 525 hours, military problems 1203, public institutions 19, misc. scientific institutions 307, the aircraft industry 1120, misc. industries 275, insurance companies 80, MNA internal work 267. In addition, the data shows that from a mathematical standpoint matrix calculations (mostly inversions of large matrices) accounted for 50% of the time, differential equations (both ordinary and partial) 29%, function evaluation 12%, statistics 4%, determination of extremum values 2%, number theory 2%, misc. types 1%.

COMPUTER ENGINEERS

Engineers at the Masters and Ph.D. level with three to five years experience in advanced digital computer systems, digital techniques or control systems design are required to fill vacancies in the Automated Data Systems Development Department.

The work will consist of system studies and advanced apparatus systems development for the automated acquisition, transmission, storage, processing and display of variables data generated in the development, design and production of atomic ordnance. The systems and applications being relatively new in concept offer unlimited horizons for highly creative and imaginative individuals.

Sandia Corporation, located in Albuquerque, N.M., is engaged in research and development of nuclear weapons and other projects for the AEC. Albuquerque is a modern city of about 225,000; has an excellent climate and many cultural and recreational attractions. Winters are mild, summer nights are cool, and there's plenty of year-around sunshine. Sandia's liberal employee benefits include generous vacations, retirement and insurance plans, and a graduate education assistance program. Paid relocation allowance. Send resume to Staff Employment Section 520.



Industrial Production

Great interest has been shown in the BESK; as a result, SAAB (Svenska Aeroplan AB) has been commissioned to handle their industrial production. Facit Enterprises has undertaken the design of an improved model and is in fact selling one to the Board. Delivery is set for sometime in 1959 or 1960. An ambitious program of modernization and expansion has been planned. The present BESK shall, in the near future, be modified so as to include built-in floating point arithmetic. The new machine, on the other hand, shall have an enlarged memory and a revised operation list though lacking the floating point feature. An extensive use of punch cards and magnetic tapes is also contemplated.

As knowledge regarding the potentialities of the electronic digital computer diffuses through the various segments of Swedish industry the need for larger and faster machines will grow. I am sure the Board's research and development program will continue at an unabated pace, contributing not only to the particular need of this society but also to the general state of the art.

CALENDAR OF COMING EVENTS

- Nov. 4-6, 1959: National Automatic Control Conference, Sheraton Hotel, Dallas, Texas.
- Nov. 11-13, 1959: 16th National Meeting, Operations Research Society of America, Huntington Sheraton Hotel, Pasadena, Calif.
- Nov. 17-19, 1959: Northeast Electronics Research and Engineering Meeting, Commonwealth Armory, Boston, Mass.
- Dec. 1-2, 1959: 4th Midwest Symposium on Circuit Theory, Marquette Univ., Milwaukee, Wisc.
- Dec. 1-3, 1959: Eastern Joint Computer Conference, Statler Hotel, Boston, Mass.
- March 21-24, 1960: IRE National Convention, Coliseum and Waldorf Astoria Hotel, New York, N.Y.
- Apr. 18-19, 1960: Third Annual Conference on Automatic Techniques, Cleveland-Sheraton Hotel, Cleveland, Ohio.
- May 2-6, 1960: Western Joint Computer Conference, San Francisco, Calif.
- Aug. 23-25, 1960: National ACM Convention, Marquette University, Milwaukee, Wisc.

STATEMENT OF OWNERSHIP AND MANAGEMENT OF COMPUTERS AND AUTOMATION

Computers and Automation is published monthly at Boston, Mass.

1. The names and addresses of the publisher, editor, managing editor, and business manager are:

Publisher, Berkeley Enterprises, Inc., 815 Washington St., Newtonville 60, Mass.

Editor, managing editor, and business manager, Edmund C. Berkeley, 34 Otis St., Newtonville 60, Mass.

2. The owner is: Berkeley Enterprises, Inc., 815 Washington St., Newtonville 60, Mass.

Stockholders holding one percent or more of the stock are: Edmund C. Berkeley, 34 Otis St., Newtonville 60, Mass.

William L. Mandel, P.O. Box 8002, Jersey City 8, N.J.

Max S. Weinstein, 25 Highland Drive, Albany 3, N.Y.

3. The known bondholders, mortgagees, and other security holders owning or holding one percent or more of the total amount of bonds, mortgages, or other securities are: None.

Edmund C. Berkeley, Editor

SWORN TO and subscribed before me, a notary public in the Commonwealth of Massachusetts, on October 14, 1959.

Esther W. McHugh, Notary Public

My commission expires October 31, 1964.

COMPUTERS and AUTOMATION for November, 1959

Make over 200 Small
Computing and Reasoning
Machines with . . .

BRAINIAC

NEW 1959-60 ELECTRIC BRAIN CONSTRUCTION KIT

WHAT COMES WITH YOUR BRAINIAC® KIT? All 33 experiments from our original Geniac® kit (1955), with exact wiring templates for each one. All 13 experiments from the former Tyniac kit, with exact wiring templates. 156 entirely new experiments (Brainiacs) with their solutions. Over 600 parts, as follows: 6 Multiple Switch Discs; Mounting Panel; 10 Flashlight Bulbs; 2 Multiple Socket Parts, each holding 5 bulbs; 116 Wipers, for making good electrical contact (novel design, patented); 70 Jumpers, for transfer contacts; 50 feet of Insulated Wire; Flashlight Battery; Battery Box; nuts, bolts, sponge rubber washers, hard washers, screwdriver, spintite blade, etc. ALSO: an introduction to Boolean Algebra for designing circuits; booklet "How to go from Brainiacs and Geniacs to Automatic Computers"; complete descriptions of 201 experiments and machines; over 170 circuit diagrams; list of references to computer literature.

This kit is an up-to-the-minute introduction to the design of arithmetical, logical, reasoning, computing, puzzle-solving, and game-playing circuits — for boys, students, schools, colleges, designers. It is simple enough for intelligent boys to assemble, and yet it is instructive even to engineers, because it shows how many kinds of computing and reasoning circuits can be made from simple components. This kit is the outcome of 10 years of design and development work with Geniacs and small robots by Berkeley Enterprises, Inc. With this kit and manual you can easily make over 200 small electric brain machines that display intelligent behavior and teach understanding first-hand. Each one runs on one flashlight battery; all connections with nuts and bolts; no soldering required. (Returnable for full refund if not satisfactory.) . . . Price \$18.95

WHAT CAN YOU MAKE WITH A BRAINIAC KIT?

LOGIC MACHINES

Syllogism Prover
James McCarty's Logic Machine
AND, OR, NOT, OR ELSE, IF . . . THEN, IF AND ONLY
IF, NEITHER . . . NOR Machines
A Simple Kalin-Burkhart Logical Truth Calculator
The Magazine Editor's Argument
The Rule About Semicolons and Commas
The Farnsworth Car Pool

GAME-PLAYING MACHINES

Tit-Tat-Toe
Black Match
Nim
Sundorra 21
Frank McChesney's Wheeled Bandit

COMPUTERS — to add, subtract, multiply, divide, ,
using decimal or binary numbers.
— to convert from decimal to other scales of notation and
vice versa, etc.

Operating with Infinity
Adding Indefinite Quantities
Factoring Any Number from 45 to 60
Prime Number Indicator for Numbers 1 to 100
Thirty Days Hath September
Three Day Weekend for Christmas
Calendar Good for Forty Years 1950 to 1989
Money Changing Machine
Four by Four Magic Square
Character of Roots of a Quadratic
Ten Basic Formulas of Integration

PUZZLE-SOLVING MACHINES

The Missionaries and the Cannibals
The Daisy Petal Machine
Calvin's Eenie Meenie Minie Moe Machine
The Cider Pouring Problem
The Mysterious Multiples of 76923, of 369, etc.
Bruce Campbell's Will
The Fox, Hen, Corn, and Hired Man
The Uranium Shipment and the Space Pirates
General Alarm at the Fortress of Dredaeerie

The Two Suspicious Husbands at Great North Bay
The Submarine Rescue Chamber Squalux
The Three Monkeys Who Spurned Evil
Signals on the Mango Blossom Special
The Automatic Elevator in Hoboken
Timothy's Mink Traps
Josephine's Man Trap
Douglas Macdonald's Will
Word Puzzle with TRICK

QUIZ MACHINES

The Waxing and the Waning Moon
Intelligence Test
Guessing Helen's Age
Geography Quiz
Mr. Hardstone's Grammar Test
Solving Right Triangles

SIGNALING MACHINES

The Jiminy Soap Advertising Sign
The Sign that Spells Alice
Tom, Dick, and Harry's Private Signaling Channels
Jim's and Ed's Intercom

CRYPTOGRAPHIC MACHINES

Secret Coder
Secret Decoder
Lock with 65,000 Combinations
Lock with 15,000,000 Combinations
The General Combination Lock
Leonard's Two-Way Coding Machine

. . . AND MANY MORE

----- MAIL THIS REQUEST or a copy of it -----

Berkeley Enterprises, Inc.
815 Washington Street, R144, Newtonville 60, Mass.

Please send me BRAINIAC KIT K18, including manual, instructions, over 600 parts, templates, circuit diagrams, etc. I enclose \$18.95 for the kit plus.....for handling and shipping (30c, east of Mississippi; 80c, west of Mississippi; \$1.80, outside U.S.). I understand the kit is returnable in seven days for full refund if not satisfactory (if in good condition).

My name and address are attached.

AUTOMATIC SEARCHING OF CHEMICAL LITERATURE

National Bureau of Standards
Washington 25, D.C.

The National Bureau of Standards and the Patent Office have been cooperatively studying the technical aspects of patent searching to find methods for mechanizing the search process as much as possible.

One of the major tasks in the cooperation effort has been to develop a program for automatic searching of patents by making use of an electronic computer. This program, known as HAYSTAQ, has resulted in an experimental system designed for the storage, search, and retrieval of technical literature, particularly in the field of chemistry. The studies are being carried out by Mrs. E. Marden of the Bureau's data processing systems laboratory and H. R. Koller and H. Pfeffer of the Patent Office.

Although systems of this type will not eliminate completely the manual literature search required of a patent examiner, they may be expected to reduce such search to relatively few documents.

Simulation of Manual Search

The HAYSTAQ system simulates on an electronic computer certain features of the manual search which a patent examiner now makes; this system has been programmed for SEAC, the Bureau's high-speed computer. Although the investigation so far has been concerned with the literature of chemistry, an attempt has been made to develop principles broad enough to include other scientific categories. The system consists essentially of four parts: (1) A data-assembly and data-checking routine for the complete disclosure file of information to be searched, (2) a data preparation routine for the question to be asked of the file, (3) the search routine itself, with all of its included sub-routines, and (4) the "checkout" routine, which evaluates the apparent answers found to questions.

At the present time, the system requires that a technically trained person read and analyze each document, and that he designate the portions to be coded for the automatic search.

Ordering of Information in a Disclosure

Before a patent application is coded for searching, it must be inspected closely to determine how much and what kinds of information it contains, and to evaluate the relative importance of the various pieces of information. The information in a disclosure on chemistry is arranged in a hierarchy of relationships. The largest segment treated is a complete chemical process with all of its disclosed steps. The next largest segment is a composition or admixture. Each composition is subdivided into groups of ingredients, with groups represented by numerical codes. The individual units within such a group are called descriptors, and may represent such items as individual atoms or bonds or substructures containing a number of different kinds of atoms. Superimposed upon this hierarchy is provision for recognizing such other relationships as alternativeness, equivalence, absence, and negativeness.

The search procedure is essentially a "matching" process on all levels to find like components. Provision is also made for recognition of a smaller configuration included in a larger one. The inclusion of such concepts results in a multiplicity of mutually exclusive search paths, and permits a great variation in the kinds of searches to be made. At all levels of the hierarchy, there is an effort to screen out as soon as possible those documents that will not provide an answer. The screens used are themselves ordered as to their probable effectiveness. In all of the data, for both question and disclosure, the descriptors are arranged in an ordered sequence to make it easier to terminate unprofitable searches.

Typical of the questions which were asked in the first generalized pilot program was the following:

$$H = - \sum_{i=1}^n P_i \log P_i$$

TI's *Central Research Laboratory* has an immediate opening for a PhD in Applied Mathematics. Will be responsible for identifying as well as solving problems and should be an individual capable of organizing his own program of activity. This opening requires a person who has performed extensive work in the fields of probability and statistics. Other qualifications include experience in numerical analysis and an intimate knowledge of the basic theorems and principles of information theory. If interested in joining this research group...working in this new 87,000 sq ft research center, please write:

Leigh Watson, Dept. 9614

CENTRAL RESEARCH LABORATORY

TEXAS INSTRUMENTS
INCORPORATED
P. O. Box 1079 • Dallas, Texas

"Find a disclosure of a non-aqueous composition, for use against fever and ague, comprising boneset; an alkylated cyclohexenyl hydrocarbon containing at least 7 carbon atoms and one double bond; an acyclic ketone consisting of 11 carbon atoms, one oxygen atom and one double bond; a member of the group consisting of quinine and cinchonidine; and as a flavoring agent, an extract of the family pinaceae containing an alkylated cyclohexenyl alcohol containing at least one hydrogen atom, one oxygen atom, 10 carbon atoms, and one double bond."

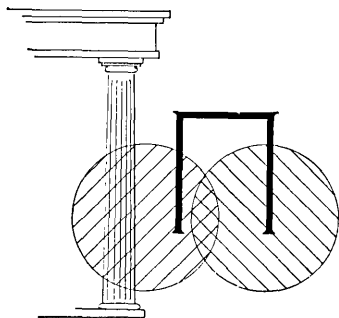

Search Routine

The search routine is in one sense a monitor of supervisory routine, which selects a search path after looking into the nature of the question being asked and the characteristics of the document being searched. This routine is a kind of assembly program for the required subroutines, where some of the subroutines are longer than the entire routine itself.

Test runs of the general program revealed certain inadequacies in the description of chemical compounds; therefore a very large detailed program for tracing the topology of functional groupings of structures within the compound was planned and executed. This subroutine takes into account many of the difficulties presented by the peculiar technical aspects of patent searching.

Included in this topological tracing subroutine are several relatively sophisticated concepts. Of great concern to a patent examiner is the need to ask a search question generically. Two provisions for doing this are incorporated in the topological tracing subroutine: one makes it possible to ask for a genus and to accept as an answer any specific member of the genus; the other takes into account the problem of the structural "Markush group." By "Markush group" is meant a synthetic genus whose scope is determined by listing all of its members. That is, a single structural entity may define an entire class of compounds by showing a fixed nucleus with various alternate constituents listed at particular points in its topological diagram. It is possible to specify for a Markush group that in addition to acceptance of any one of the listed members of the group, the program will be satisfied with "no substituent" for that connection.

To carry out the tracing, a basic vocabulary was devised of functional groups within the whole chemical structure. The data to be handled consist of a listing of all such groups, together with their connective relationships to each other, including the bond types. Several screens are employed to eliminate in certain cases the topological tracing. In the data making up one screen, all terms are listed that represent combinations of chemical significance found in the structure. These terms are made up of at least two functional groups in the topo-

logical section, and their definitions are fixed and constant. In another screen, generic concepts found in the structure are listed and, where required, defined in terms of the specific functional groups pertinent to the structures under consideration. By referring to these two listings, the program bypasses many unrewarding searches.

In the topological tracing, as like groups are found, or matched, a table of equivalents is set up of the question groups and of the matching groups actually answering the question. Normally, merely the document number is given by the program as a reference, but in certain complex cases, this "Equivalence Table," which lists all successful matches, can be printed out in its entirety. As it is possible to follow a false trail for a short distance, the program provides for backing up and looking for a re-match.

Recent Work

The most recent work in the HAYSTAQ system has been concerned with the programming of an automatic data-assembly and data-checking routine for the topological tracing program, and the compilation of a large experimental test file. By trying a variety of test questions against the file, it will be possible to gather some meaningful statistics pointing toward the most profitable directions for future research in information retrieval.

For further technical information see *The HAYSTAQ system: past, present and future*, by H. R. Koller, E. Marden, and H. Pfeffer. Preprints of papers for the International Conference on Scientific Information, Washington, D.C., Nov. 16-21, 1958; *Organization of chemical disclosures for mechanized retrieval*, Patent Office Research and Development Report No. 5, U.S. Patent Office, Washington 25, D.C.

RESEARCH ASSIGNMENTS FOR SENIOR MEMBERS OF THE TECHNICAL STAFF AT CENTRAL RESEARCH LABORATORY



TEXAS INSTRUMENTS INCORPORATED

Permanent openings in the Central Research Laboratory—Texas Instruments research center—present challenging opportunities for Scientists and Engineers to expand their professional potential in stimulating growth assignments. Here, in Central Research Laboratory, you will enjoy freedom of scientific and professional expression while working for a company noted for unusually generous personnel benefits, including profit sharing (in 1958, 15% of base salary).

COMPUTING SYSTEMS DESIGN—Responsible for systems and logic design of special purpose real-time computing systems. Should be capable of deriving an optimum computing system configuration, given a class of problems to be solved. Educational requirements: MS or PhD in EE or Physics.

DIGITAL CIRCUITS—Responsible for circuit analysis, design and the development of special purpose real-time computing systems. A considerable portion of the circuit work will involve the application of new computer devices. Educational requirements: MS or PhD in EE or Physics.

DATA TRANSMISSION SYSTEMS—Responsible for the design and development of long-range, high capacity digital data transmission systems. A familiarity with information theory, including optimal encoding and decoding schemes for reliable transmission in the presence of noise is desirable. Educational requirements: MS or PhD in EE or Physics.

To learn more about how you can join this fast-growing company in one of these exceptional career opportunities, please write:

LEIGH WATSON, Dept. 9614
CENTRAL RESEARCH LABORATORY
TEXAS INSTRUMENTS
INCORPORATED
BOX 1079 • DALLAS, TEXAS

Computers And Automation In The U.S.S.R.

Enoch J. Haga
Vacaville, California

This article reports gleanings on computers and automation taken from the first thirty-two issues of the *USSR Illustrated Monthly*. While computers and automation are frequently mentioned in this publication, especially when speaking in terms of the future, this report is confined to repeating what the Soviet editors say has already been achieved.

Electronic Computers

The Institute of Precision Mechanics and Computing Techniques, located in a three-story building on Kaluzhskoye Avenue in Moscow, contains a laboratory for the development of computers. Here the Lebedev computer, a machine designed and built by a group headed by Academician Sergei Lebedev, is located. Operated by one technician and two engineers, this machine works around the clock on schedule.

Components

The machine contains some 5,000 electronic tubes, each with a life of some 10,000 hours. In later models the tubes

have been replaced by transistors. The arithmetic device uses electronic counting circuits. Output is by magnetic tape. The major memory devices are cathode ray tubes that store numbers in the form of charges on the screens; capacity is 1,023 numbers. Twelve millionths of a second is the time required to select a number and record the result. Speed of the machine is, on the average, 7,000 to 8,000 additions per second. Multiplication time is 192 millionths of a second. Supplementary but slower memory is available in either a magnetic drum storing 5,120 numbers, or magnetic tape, storing 120,000 numbers.

Applications

This machine computed for the International Astronomical Calendar, in a few days, "the orbital movements of about 700 asteroids . . . with allowances for the influence exerted on them by Jupiter and Saturn." Also "their coordinates were determined for the next ten years, their locations at the end of every 40 days being calculated exactly." Solutions to systems of algebraic equations with many unknowns were computed for map-making based on geodetic surveys. The machine solved, in less than 20 hours, problems of 800 equations requiring some 250 million calculations.

A French scientific text is being translated into Russian on the machine. Alexander Nesmeyanov, President of the USSR Academy of Sciences, said that the machine "made the translation from English into Russian faster and more competently than any of the three translators who were working simultaneously for the sake of comparison."

Other Computers

A machine called the *Ural Machine*, has been produced in quantity, and is used for university research and to solve engineering problems. Another computer, the *M-2 Machine*, is also in operation.

Computing Centers

Besides Moscow, functioning computing centers are located at Yerevan, Tashkent, Alma-Ata, and at other places. The USSR Academy of Sciences also has a general purpose electronic computer.

Computer Production

In the year 1955, 24 per cent more computing machines were made than in 1954. The Sixth Five-Year Plan (1955-1960) called for a 450 per cent increase in computer production. [Unfortunately, no base figures were given, and percentage figures are largely meaningless without them.] Mention is made that electronic computers are manufactured in Riga.



computer designers: career progress stopped up?

Data Systems can pull the stopper. Computer design and development engineers are needed to work on a variety of commercial projects. These include automatic industrial controls, special purpose digital data processing equipment, and advanced mark sensing systems involving high speed paper handling devices. Expansion of the department to twice its present size in the next six months is creating plenty of room for fast advancement. Pay schedules are excellent. Working conditions are ideal. A new facility is planned for the Newport Beach (Southern California) area.

If your present position has lost its challenge, or if you feel you're ready for the next step up, contact John Flynn, Area 21.

Data Systems Dept.
NORDEN DIVISION
UNITED AIRCRAFT CORPORATION
13210 Crenshaw Boulevard • Gardena, California

Industrial Automation

The Soviets recognize the prime importance of mechanization and automation in increasing industrial output. The Sixth Five-Year Plan (1955-1960) called for a 500 per cent increase in production of semi-automatic and automatic production lines and equipment; control instrument production was to increase by 400 per cent; at least some 32 instrument-making plants were to be built. There are now 1,840,000 machine tools in the metal-working industry, as compared with 710,000 prewar; the number of semi-automatic and automatic machines has increased to nearly three times the prewar level.

In the machine-tool industry the Soviets have in mind the following sequence in their program of planned automation:

- 1—Use of manual universal machine tools.
- 2—Semi-automatic and automatic universal machine tools.
- 3—Semi-automatic and automatic *specialized* machine tools.
- 4—Machine tool trains.
- 5—Machine tool trains with program control operating in automatic production lines.

Program-controlled universal machine tools are said to operate with tolerances as close as .0039 of an inch. In 1956 alone, some 1,500 automatic and conveyORIZED lines were added to Soviet industry.

Automated Industries

Automation has been most swift in the following industries: power, iron and steel, chemicals (especially conversion of wood pulp into silk fiber, and petroleum gas into alcohol), oil refining, and food production. A slower rate of automation is found in the areas of electrical and radio engineering, machine building (especially founding, pressing, forging, heating, watch production, and ball bearings), transport, and light industries. Automation has been introduced more or less, in: mining, production of building materials, footwear manufacture, communications, steamships, dredging and related work. Automation is also proceeding in coal, ores, timber, agriculture, and construction. Following are some examples of what is being done.

Automatic Production Lines

Three thousand wax milk cartons are turned out per hour in an automatic installation made by the Leningrad Krasnaya Vagranka plant; in Latvia an automatic line makes relay springs; in the Altai area cans are turned out at a meat-packing plant by automatic machines; in Asbest, in the Urals, a building materials plant has been automated; continuous steel casting is fully automated in many steel works; the First Moscow Ball-Bearing Plant has an automated line; in Tallinn, Estonia, the Volta Electrical Engineering Factory turns out precision-tooled shafts for electric motors on an automatic line; the Sverdlovsk Bearing Works is in process of automating many of its shops; most shoe factories, like the Leningrad Skorokhod Shoe Factory, are being automated; in the Urals, at the Magnitogorsk Iron and Steel Works, a group of workers is automating the entire steel-making process; an automatic stamping machine increased output fifteen times in the VEF, Riga, electrical engineering plant; a Lenin Prize has been awarded for designing and producing a set of efficient automated

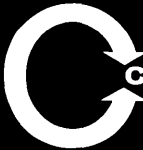

CLARE ANNOUNCES
THE Type 211
Stepping Switch

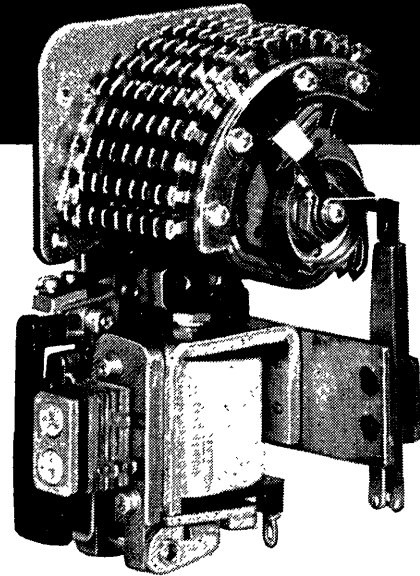

Eleven-point stepping switch has 12-level capacity, 100,000,000-step* life

Many new, improved features give this Clare Type 211 springdriven stepping switch longer service life, greater capacity and a freedom from maintenance hitherto unknown in an 11-point switch. Rugged, compactly built, the 211 is available with a variety of enclosures and mounting assemblies to meet a wide range of design applications.

***LONGER LIFE EXPECTANCY**—This new switch has a life expectancy of from 100 million steps at twelve levels to 300 million steps at three levels with proper relubrication and readjustment.

GREATER STEP CAPACITY—Up to twelve 11-point levels or four 33-point levels enable it to handle complex switching, counting, totalizing, selecting, and sequence control operations.

SIMPLIFIED MAINTENANCE—Fewer moving parts, due to the elimination of pawl bearings, and a more rigid armature arm simplify maintenance and increase service life.

VARIETY OF ENCLOSURES—Hermetically sealed enclosures, filled with nitrogen or oil, are available with hook-type solder terminals. Dust cover enclosures are available with miniature or standard Amphenol Blue Ribbon connectors.

Write for bulletin CPC-3 to C. P. Clare & Co., 3101 Pratt Blvd., Chicago 45, Illinois. In Canada: C. P. Clare Canada Ltd., P. O. Box 134, Downsview, Ontario. Cable Address: CLARELAY.

CLARE RELAYS
FIRST in the industrial field

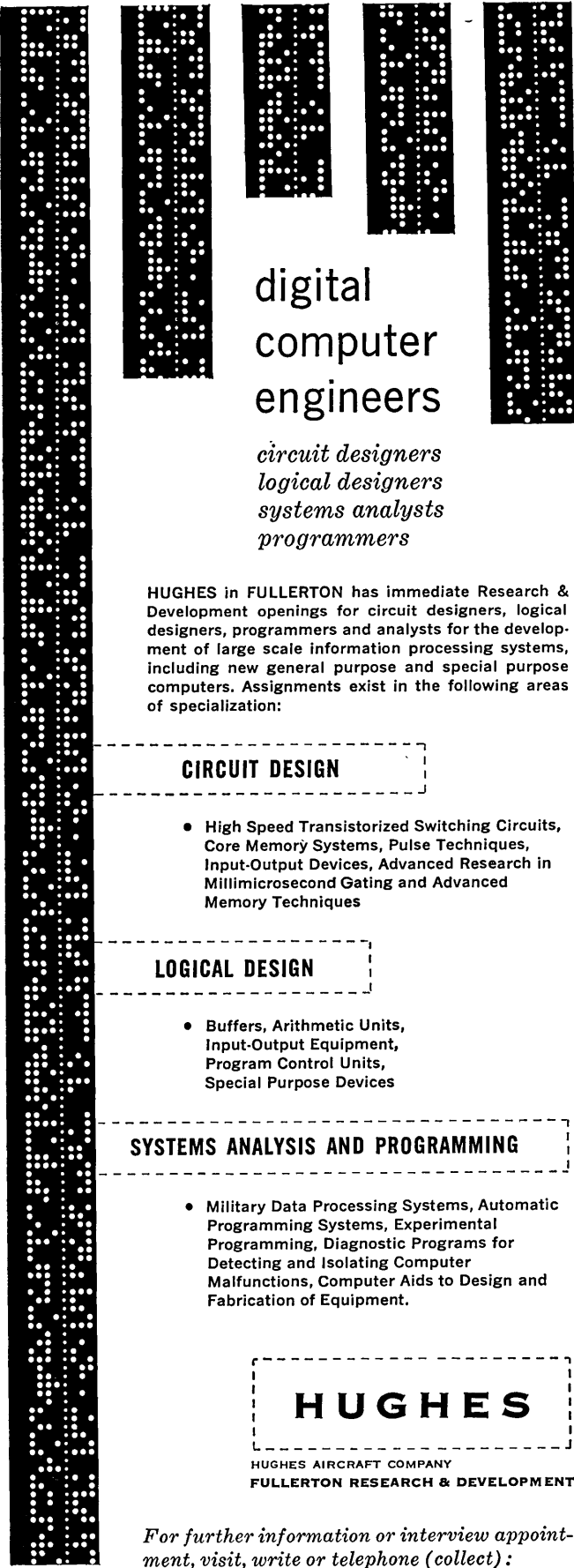

digital computer engineers

*circuit designers
logical designers
systems analysts
programmers*

HUGHES in FULLERTON has immediate Research & Development openings for circuit designers, logical designers, programmers and analysts for the development of large scale information processing systems, including new general purpose and special purpose computers. Assignments exist in the following areas of specialization:

CIRCUIT DESIGN

- High Speed Transistorized Switching Circuits, Core Memory Systems, Pulse Techniques, Input-Output Devices, Advanced Research in Millimicrosecond Gating and Advanced Memory Techniques

LOGICAL DESIGN

- Buffers, Arithmetic Units, Input-Output Equipment, Program Control Units, Special Purpose Devices

SYSTEMS ANALYSIS AND PROGRAMMING

- Military Data Processing Systems, Automatic Programming Systems, Experimental Programming, Diagnostic Programs for Detecting and Isolating Computer Malfunctions, Computer Aids to Design and Fabrication of Equipment.

HUGHES

HUGHES AIRCRAFT COMPANY
FULLERTON RESEARCH & DEVELOPMENT

For further information or interview appointment, visit, write or telephone (collect):

Mr. B. P. RAMSTACK

*Hughes Aircraft Company
Fullerton, Orange County, So. California
Telephone: MADison 9-5211, Los Angeles*

machine tools for cutting bevel gears; many fully automatic hydroelectric stations now need no personnel on permanent duty.

Automation at Work

At the Moscow First Bearing Plant, a machine tool design team headed by Serafim Vlasov, developer of a fully automated shop for the mass production of bearings, worked out completely automated processes for mechanical and thermal treatment of bearing races, assembly and packing of bearings; the number of operators was cut in half, and production increased by 90 per cent.

At the USSR Industrial Exhibition in Moscow, some of the displays were: a tool that will form six crank shafts of different configuration; automatic lathes, that once set up by a human operator, can center, cut, then polish and clean thirteen different parts; an automatic knitting machine that runs one hundred twelve bobbins with each thread controlled by an independent electric self-stopper.

Soviet satellite tracking stations utilize automated radar installations. A coordination center using electronic computers analyzes trajectory measurements, determines the elements of the orbit, and issues instructions to the tracking installations.

Automatic control has been applied to operating a unified power system hundreds of miles long. A control for the system has been developed by the Power Systems Laboratory of the Academy of Sciences.

An automatic control system drove a three-car train on a test run starting from Kuntsevo station near Moscow. The system computer does 2,000 mathematical operations in a second and solves differential equations of the train's movements, allowing for weight of the train and load, the force of the brakes, the grade, and the timetable. Data such as the grade of track and length of line are carried coded in a "memory block."

Automated Farms

On a state farm near Moscow two men, by button-pushing, prepare feed for 1,000 pigs; only one truck driver is needed to unload the fodder; one swineherd can care for 1,000 pigs.

Using the principle of the industrial conveyor, an all-inclusive system of farm mechanization has been worked out covering over 1,000 different kinds of machines suited to varied zones.

Training for Automation

The highly skilled jobs of regulating automatic and semi-automatic equipment require, in the engineering industries, four years of vocational training.

SOURCES

USSR Illustrated Monthly, first 32 issues; see especially: Frolov, Ivan, "Robot Locomotive Engineer," No. 2 (29), p. 44.

Mokletsov, Alexander, "Home Made Robots and Helicopters," No. 11 (26), pp. 60-61.

Pekelis, Victor, "Thinking Machines," No. 3, pp. 44-45.

Shaumyan, Grigori, "Men and Machines, Automation in the Soviet Union," No. 10, pp. 38-41.

_____, "Tomorrow's Machine Will Do Man's Physical Labor," No. 4 (19), p. 13.

SURVEY OF RECENT ARTICLES

Moses M. Berlin

Cambridge, Mass.

We publish here a survey of articles related to computers and data processors, and their applications and implications, occurring in certain magazines. We seek to cover at least the following magazines:

Automatic Control
Automation
Automation and Automatic
Equipment News (British)
Business Week
Control Engineering
Datamation
Electronic Design
Electronics
Harvard Business Review
Industrial Research
Instruments and Control
Systems
ISA Journal
Proceedings of the IRE
Management Science
The Office
Scientific American

The purpose of this type of reference information is to help anybody interested in computers find articles of particular relation to this field in these magazines.

For each article, we shall publish: the title of the article / the name of the author(s) / the magazine and issue where it appears / the publisher's name and address / two or three sentences telling what the article is about.

Self-Reproducing Machines / L.S. Penrose / Scientific American, vol. 200, no 6, June '59, p 105 / Scientific American, Inc., 415 Madison Ave., New York 17, N.Y.

Experiments have been made building simple machines which assemble themselves through shaking, etc. into larger units. These lead to self-reproducing multiple copies from simple units. The process sheds light on the self-reproduction of biological molecules.

The Cryosar — A New Low-Temperature Computer Component / A. L. McWhorter and R. H. Rediker, Lincoln Lab., M.I.T., Lexington, Mass. / Proceedings of the IRE, vol. 47, no. 7, July, 1959, p 1207 / IRE, Inc., 1 East 79 St., New York 21, N.Y.

The cryosar is a high-speed two-term-

inal computer component whose operation is based on "impact ionization of impurities in germanium." This article discusses two types of cryosars, fabricated using uncompensated germanium, and fabricated using compensated germanium. The discussion covers the functioning of the cryosars.

Stored Program Computation with Pitfalls and Booby Traps / W. B. Lewis, Director, Theoretical Physics and Applied Mathematics Section, Atomic Energy Div., Phillips Petroleum Co. / Computing News, vol. 7, no. 15, Aug. 1, 1959, p 154 — 11 / C. N., P.O. Box 90424, Airport Station, Los Angeles 45, Calif.

Two of the many problems that require the use of a computer are discussed: (1) problems whose dependent variables are not readily expressed as explicit functions of the independent variables, or, more generally, problems whose solutions require an iterative procedure; (2) problems characterized by sheer tedium. A specific example is given, combining the situations that occur in both problem types.

Computer "Clerks" Help to Control Air Traffic / Management and Business Automation, vol. 2, no. 1, July, 1959, p 6 / The Office Appliance Co., 600 W. Jackson Blvd., Chicago 6, Ill.

A file computer plays an important role in solving traffic problems at New York's Idlewild International Airport. The computer performs all the paper work involved in controlling landings and take-offs. Plans are being formulated to link the New York airport's computer with the one at the Washington, D.C. airport.

Mechanical Translation and its Implications in Data Processing / A. D. Booth / Automatic Data Processing, vol. 1, no. 6, July, 1959, p 18 / Business Publications Ltd., 180 Fleet St., London, EC 4.

This article traces the development of language translation by computer. Some of the techniques are discussed, followed by brief notes on the effect of automatic translation on dictionary making and a listing of some commercial uses of automatic translation.

Process Computer Control Concepts / A. Freilich, Burroughs Corp., Res. Center, Paoli, Pa. / ISA Journal, vol. 6, no. 7, July, 1959, p 47 / Instrument Society of America, 313 Sixth Ave., Pittsburgh 22, Pa.

A discussion of automatic optimization by mathematical model and direct ex-

perimentation, including "off-line" operating guides, "on-line" operating guides, sampling in digital control loops, and a conclusion about the computer as an experimental controller.

Indexing and Control-Word Techniques / G. A. Blaauw / IBM Journal of Research and Development, vol. 3, no. 3, July, 1959, p 288 / IBM Corp., 590 Madison Ave., New York 22, N.Y.

Large-scale computers usually provide for the handling of certain details such as indexing, data transmission, and ordering by the programmer or by built-in machine operations. This article points out that allowing the computer to handle these details leads to greater accuracy and speed. The article then describes a computer being developed, which is designed to perform more of the frequently needed functions automatically.

Instrumentation and Computation in Process Development and Plant Design / Automation and Automatic Equipment News, vol. 4, no. 11, July, 1959, p 1248 / A. & A. E. N., 9 Gough Sq., Fleet St., London E. C. 4

A three-day symposium on the above listed topic was held in England, in May, 1959. The various papers which were presented discussed the computer as an essential tool in a number of processes. Particularly, computer applications in chemical problems were discussed.

Automation Again on Political Agendas? / J. W. Murray / Automation and Automatic Equipment News, vol. 4, no. 11, July, 1959, p 1246 / A. & A. E. N., 9 Gough Sq., Fleet St., London, E. C. 4

Three autumn conferences in Great Britain will propose suggestions on further uses of automation. Viewing automation as the necessary means of meeting overseas competition, British industry will implement automatic procedures to make greater use of manpower, particularly, older employees.

Computers in the Iron & Steel Industry / D. Whipp / Automation and Automatic Equipment News, vol. 4, no. 11, July, 1959, p 1264 / A. & A. E. N., 9 Gough Sq., Fleet St., London, E. C. 4

This article includes topics discussed at a conference held by the Steel Industry, on computers. Among the main papers are, "Experience in Using a Computer for Payroll," "A Simulation of Melting Shop Operations by Means of a Computer." "The Use of a Computer in a Rolling Mill Office," and "Training for Computers."

Annals of the International Association for Analog Computation, vol. 1, no. 4, March, 1959, pp 123-217 / Presses Academiques Europeennes, 98 Chaussée de Charleroi, Bruxelles 6B, Belgium / printed, 1959, 90 Belgian francs
With occasional summaries in English and/or German this publication contains 2 articles on analog computer problems, in French. The publication also includes a bibliography and résumés of articles on analog computers and applications.

Mapping System Uses Digital Printer / P. Kintner, Airborne Instruments Lab., Div. of Cutler-Hammer, Inc. / Instruments and Control Systems, vol. 32, no. 6, June, 1959, p 890 / Instruments Publishing Co., Inc., 845 Ridge Ave., Pittsburgh 12, Pa.

A system for accurately measuring elevations, and for determining coordinates of points in mapping processes, uses a computer in the following ways: Data taken from the mapping machine will be prepared for entry into the computer, a Bendix G-15; digital output values will be displayed visually; the input and output will be recorded; and the output will be stored to allow for comparison with other data.

Tape Systems / Instruments & Control Systems, vol. 32, no. 5, June, 1959, p 892 / Instruments Publishing Co., 845 Ridge Ave., Pittsburgh 12, Pa.

This brief article describes some systems used by the military and industry, which make use of magnetic tape equipments. Basic equipments and applications are shown.

DIGITAL ANALYST

To logically design, evaluate and select digital computers for inertial guidance and surveillance systems programs. Experience desired in digital systems analysis, logical systems design, Z transform analysis of digital servo loops and digital computer error analysis.

To arrange interview call collect, Niagara Falls
BUtler 5-7851, or send resume to:

**Supervisor Engineering
Employment**

**BELL AIRCRAFT
CORPORATION**

BUFFALO 5, NEW YORK

Analog-Digital Converters — Part 2 / Elechtromechanical Design, vol. 3, no. 7, July, 1959, pp 47-60 / Benwill Pub. Corp., 1357 Washington St., West Newton 65, Mass.

This article, in the Components Digest no. 7, has been compiled from "Notes on Analog-Digital Conversion Techniques," edited by A. K. Susskind, and from information furnished by engineers at Epsco, Inc. It includes comparisons of brush and optical type shaft encoders, optical reading systems, voltage encoders, accuracy considerations, and speed requirements.

Thin Magnetic Films for Digital Computer Memories / D. O. Smith, Lincoln Lab., M. I. T., Lexington, Mass. / Electronics, vol. 32, no. 26, June 26, 1959, p 44 / McGraw-Hill, 330 West 42 St., New York 36, N.Y.

Tiny dots consisting of magnetic alloys can be deposited on planes and cylinders in the hardware of the computer, providing for high speed memories with large capacities. The tiny magnetic films can also be manufactured economically. Two tables are given, the first showing present and probable properties of ferrite cores and planar magnetic films, the second, a comparison of planar and cylindrical magnetic films.

Soviet Exhibition Provides Close Look at Control Element / Automatic Control, vol. 11, no. 2, August, 1959, p 18 / Reinhold Pub. Corp., 430 Park Ave., New York 22, N.Y.

Automatic control technology was a dominant theme at the USSR exhibition, held at the Coliseum, New York City. This brief report includes photos of two of the analog computers that were displayed, both of which are being put into production to serve as teaching and design tools for the dynamic analysis of automatic control.

Computers in Process Control / Control Engineering, vol. 6, no. 7, July, 1959, p 40 / McGraw-Hill Pub. Co. Inc., 330 West 42 St., New York 36, N.Y.

A variety of uses for analog and digital computers in process control were discussed at a symposium on "Instrumentation and Computation in Process Development and Plant Design." One of the conclusions reached by those in attendance was that theoretical applications far exceed actual applications.

Where to Look for Trouble in a New EDP Installation / B. Conway and D. E. Watts, Price Waterhouse & Co. / Control Engineering, vol. 6, no. 7, July, 1959, p 104 / McGraw-Hill Pub. Co. Inc., 330 West 42 St., New York 36, N.Y.

This article offers advice to companies planning the installation of computer systems. A number of pitfalls are mentioned, with methods of avoiding them. Preliminary planning, proper staffing, and system design, are discussed.

Structural Diagrams — A Short-cut to Analog Computer Circuits / O. Follinger and W. Seifert, AEG—Institute fuer Automation, Frankfurt—Main,

Germany / Control Engineering, vol. 6, no. 7, July, 1959, p 81 / McGraw-Hill Pub. Co. Inc., 330 West 42 St., New York 36, N.Y.

A structural diagram of a system can be obtained which is immediately translatable to an analog computer circuit. Hence, it is not necessary to solve for the characteristic differential equation of the system. The "short-cut" technique is demonstrated in two examples, and a chart of the seven basic operations encountered, is given.

The Army's Newest Weapon: ADP / Control Engineering, vol. 6, no. 7, July, 1959, p 25 / McGraw-Hill Pub. Co. Inc., 330 West 42 St., New York 36, N.Y.

This article asserts that computers may become "regular issue" for tactical units of the U.S. Army. Some of the new computers which the army will use, are described, and their functions are enumerated.

Optimizing Control by Model Methods / I. Lefkowitz and D. P. Eckman, Case Institute of Technology, Cleveland, Ohio / ISA Journal, vol. 6, no. 7, July, 1959, p 74 / Instrument Society of America, 313 Sixth Ave., Pittsburgh 22, Pa.

Optimum performance by a computer may be achieved by one of two methods: (1) a direct approach in which output performance is compared with input manipulation, to determine the system behaviour; or, (2) a model method, in which the model provides the basis for analytical definition of optimizing control conditions for the system. This article discusses how the methods are used.

Available Computers and What They Do / A. Freilich, Burroughs Corp., Res. Center, Paoli, Pa. / ISA Journal, vol. 6, no. 7, July, 1959, p 54 / Instrument Society of America, 313 Sixth Ave., Pittsburgh 22, Pa.

A detailed discussion of the three general classes of computers, general purpose, analog, and incremental digital. The discussion points out that many more computers are now available in all three categories. Some of the systems are listed in tables accompanying the article.

Computer Control Installations / ISA Journal, vol. 6, no. 7, July, 1959, p 66 / Instrument Society of America, 313 Sixth Ave., Pittsburgh 22, Pa.

A list and description of computer installations, including complex installations with multiple loop control and numerous input facilities. Although the smaller installations aren't listed, wind tunnel control, weather forecasting, and traffic control centers, are given.

Alarm Circuit Warns of Faults in Digital Systems / S. Fierston, Sylvania Electronic Systems Div., Needham, Mass. / Electronics, vol. 32, no. 27, July 3, 1959, p 48 / McGraw-Hill Pub. Co. Inc., 330 West 42 St., New York 36, N.Y.

THE COMPUTER DIRECTORY AND BUYERS' GUIDE 1959

5th Annual Issue,

the only directory in the
computer field,

the June 1959 issue of
Computers and Automation

CONTENTS:

Part 1, ROSTER OF ORGANIZATIONS. Each entry gives:

Name of organization / Address / Telephone number / Types of computers, data processors, accessories, components, services, etc., produced or offered / Approximate number of employees / Year organization was established

(740 organization entries)

Part 2, BUYERS' GUIDE: ROSTER OF PRODUCTS AND SERVICES. Each expanded bold-face entry gives:

Name or identification of product or service / Brief description (20 to 50 words) / Uses / Price range, between . . . and . . .

Other entries are cross-references.

(Over 2700 product and service entries in total)

This is your indispensable guide to organizations, products, and services in the computer field — useful to you the whole year.

Send for your own copy now —

MAIL THIS COUPON
(or a copy of it)

To: Computers and Automation
815 Washington St., R144
Newtonville 60, Mass.

Please send us a copy of the 1959
Computer Directory. We enclose
\$6.00.

Name.....

Title.....

Organization.....

Address.....

Data processing systems with numerous units require flexible monitoring equipment. An audible alarm system provides the computer with distinctive indication of fault location. The alarm system consists of simple, flexible circuits which simulate horn, collision, and battle station sounds.

UNIVAC Review / Management Services Dept., Remington Rand Univac, Div., of Sperry Rand Corp., 315 Park Ave. South, New York 10, N.Y. / Summer, 1959, vol. 2, no. 2, 30 pp, cost ?

This quarterly is designed to provide a medium for the exchange of technical information covering the Univac "family" of computers. This edition contains six articles, including information on the UNIVAC Solid-State 80, and the article, "From Flight Variables to Heart Beats," which discusses practical problems to be solved by data processing.

Testing Systems by Combined Analog and Digital Simulation / R. D. Horowitz, Convair Astronautics / Control Engineering, vol. 6, no. 9, Sept., 1959, p 160 / McGraw-Hill Pub. Co., Inc., 330 West 42 St., New York 36, N.Y.

Interconnection of digital and analog computers often provides the best means of testing a simulated system. It gives rise, however, to a number of problems, which are discussed.

Criteria to Evaluate Data Processing / R. H. Johnson / Punched Card Data Processing, vol. 1, no. 5, July-Aug., 1959, p 9 / Gille Associates, Inc., 956 Maccabees Bldg., Detroit 2, Mich.

Eighteen factors of importance to management, regarding punched card or electronic data processing, are listed, with brief notes on each. Among the factors: dollar savings, ability to absorb more work, morale, reduction in training costs, and precise accuracy.

Simplify the Program and Save / H. J. Johnson, Jr. / Punched Card Data Processing, vol. 1, no. 5, July-Aug., 1959, p 25 / Gille Associates, Inc., 956 Maccabees Bldg., Detroit 2, Mich.

Less involved programs for computer applications ensure a saving in the overall cost of the data processing system. This article discusses some ideas which may lead to the simplification of programs for business applications. One of the suggestions involves writing programs which include simple tests for the accuracy of the routine.

The Forms Specialist's Place in Data Processing / R. Marien / Punched Card Data Processing, vol. 1, no. 5, July-Aug., 1959, p 15 / Gille Associates, Inc., 956 Maccabees Bldg., Detroit 2, Mich.

Data processing systems offer a challenge to the forms specialist: to design appropriate data processing forms. This article discusses some new developments in high-speed printers and punched card forms, and offers suggestions on approaches to be taken by the forms specialist.

SENIOR COMPUTER PROGRAMMERS

PROGRAMMING SYSTEM ANALYSTS

■ A major firm with operations in the vicinity of New York and Los Angeles has several positions open for those able to qualify as technical assistants to a department head—or perform advanced research in programming and computer application. The positions require a high degree of ability.

\$13M
TO
\$16M

■ In addition to its basic contractual work, the firm is engaged in a number of long-range research projects. They include investigation of: (1) computer design from a standpoint of programability rather than engineering, and (2) information retrieval.

■ Inquiries will be considered in confidence. You are invited to send your resume to
Box 15

Computers and Automation
815 Washington Street
Newtonville 60, Mass.

WHO'S WHO IN THE COMPUTER FIELD

(Supplement)



wanted: WAR GAME PLAYERS

Very large-scale air-battle digital computer simulations are now going on at the Washington Research Office of *tech/ops*. Present operations call for *top-flight mathematicians, mathematical statisticians, senior programmers, operations research analysts.*

These computer air battles are stochastic models which involve design and evaluation, and development of unusual techniques for studying sensitivity of these models to input changes. Associated activity involves design of advanced programming systems and of common language carriers which are expected to be independent of the first computer used—the computer itself augmenting and improving the language for use on later and more sophisticated computers.

If challenging work, stimulating atmosphere, and an opportunity to participate in an unusual company/employee investment program interest you . . . write or wire collect:

tech/ops

Kingsley S. Andersson

Technical Operations, Incorporated

3520 PROSPECT STREET, NORTHWEST • WASHINGTON, 7, D. C.

*Final position in the famed simultaneous exhibition at Pernau, 1910: Nimzovich (white) vs Ryckhoff (black).

A full entry in the "Who's Who in the Computer Field" consists of: name / title, organization, address / interests (the capital letters of the abbreviations are the initial letters of Applications, Business, Construction, Design, Electronics, Logic, Mathematics, Programming, Sales) / year of birth, college or last school (background), year of entering the computer field, occupation / other information such as distinctions, publications, etc. An absence of information is indicated by - (hyphen). Other abbreviations are used which may be easily guessed like those in the telephone book.

Every now and then a group of completed Who's Who entry forms come in to us together from a single organization. This is a considerable help to a compiler, and we thank the people who are kind enough to arrange this. In such cases, the organization and the address are represented by . . . (three dots).

Following are several sets of such Who's Who entries.

- General Electric Co., Computer Dept., P. O. Box 442, Tempe, Arizona.
- Andre, Milo J. / Meteorologist, . . . / A / '22, Univ. of Chicago, '59, meteorologist
- Baer, Dwane O / USAF, . . . / AP / '15, Univ of Wash, '59, U.S. Air Force
- Beck, C George / Compr Analyst, . . . / ADLMP, engg (apl to) / '17, Univ of Minn, '58, compr analyst
- Bishop, Jack D / Operns, . . . / operations / '31, —, '56, operns
- Blumke, James A / Coder, . . . / MP / '35, Ariz State Univ, '58, coder
- Brewer, Susan / prgmg analyst, . . . / A, info retrieval, language translation / '22, Notre Dame De Sion, '57, prgmg analyst
- Brown, Donald / prgmg anal, . . . / ABMP / '34, St. Josephs Col, '57, prgmg anal
- Brown, Raymond N / res mathn, . . . / AM / '29, Penn State Univ, '53, res mathn
- Casillas, Frank P / Eng Sys Modeller, . . . / ABCMP, large real time sys / '26, Purdue U, '53, eng sys modeller
- Chonolei, Morton A / Compr Anal, . . . / ABMP / '32, UCLA, ASU, '55, compr anal
- Coberly, Jr, Neal D / Prgmg Anal, . . . / ABPS / '32, Univ. of Penna, '58, prgmg anal

- Cochran, Robert B / Compr Anal, . . . / ADLP / '34, Ariz State Univ, '56, compr anal
- Dodds, Jr, W T / Compr Anal, . . . / ABP, sys studies / '33, Ariz State U, '56, compr anal
- Emrick, J. E. / Compr Oper, . . . / operations / '25, Denver Univ, '58, compr oper
- Emrick, Thomas L / Compr Sys Anal, . . . / AMP, meteorology / '27, UCLA, '54, compr sys anal
- Erickson, Donald L / Num Anal, . . . / PS / '19, S. D. State Sch of Mines, ASU, '59, num anal
- Erickson, R G / Mathn, . . . / MP / '29, Purdue Univ, '57, mathn
- Finnegan, J. W / Prgmg Anal, . . . / AMP / '28,—, '57, prgmg anal
- Harrison, Jr, Robert D / Mgr, Compr Techniques Unit, . . . / AMP / '29, Univ of Ark, '55, compr techniques / B.A. and M.A.
- Horne, John B / Prgmg Anal, . . . / ABLPS, sys anal / '23, Univ of Tex, Univ of Kans City, '55, prgmg anal / Illingworth, Jr, Henry S / Compr Program Librn, . . . / — / '22, Ariz State Col, B.S., '57, compr program librn
- Illner, Joseph E / Compr Anal, . . . / ABLPS / '27, Fenn Coll, '57, compr anal
- Jennings, Paul H / Unit Mgr, . . . / P / '26, Ariz St Coll, '55, mgm
- Johnson, Elbert J / Math Anal & Prgmr, . . . / ALMP / '23, Univ of Utah, '55, math anal & prgmr
- Johnson, Lucian D / Electl Engr, . . . / AE / '28, Univ of Ark, '59, elec engr
- Lahey, Thomas M / Prgmg Anal, . . . / ALMP / '31, Univ of Ill, '57, prgmg anal
- Lehr, Donald / Prgmg Anal, . . . / AEMP / '29, Univ of Ill, '57, prgmg anal
- Lemas, Manuel R / Compr Anal, . . . / ALP / '35, New Mex A & MA, '55, compr anal
- Lemons, Richard C / Compr Engr, . . . / ADLPS / '32, M.S.E. (Ariz State Univ), '54, compr engr
- Litka, Donald F / Compr Anal, . . . / AP / '32, Tufts Univ, '59, compr anal
- McMillan, Roderick E / Compr Anal, . . . / AP / '33, Maryville Coll, '57, compr anal
- Moore, Richard E / Compr Anal, . . . / ABLP / '30, Ariz State Univ, '56, compr anal
- Nelson, Douglas M / Coder, . . . / ABP, integrated data prog / '33, Ariz State Univ, '58, coder
- Nicoll, Robert C / Prgmg Techniques Anal, . . . / ALMP / '25, K.C. Univ, '53, prgmg techniques anal
- Ogle, John J / Mathn, . . . / AMP / '28, Columbia Univ, '55, mathn (specialist; mil sys)
- Perkinson, William L / Compr Anal, . . . / MP / '31, Nwn Univ, '59, compr anal
- Roberts, Penelope / Num Anal, . . . / AP / '37, Univ of Houston, '59, num anal
- Rogalski, Chester / Prgmr, . . . / AMP, systems / '24, Eureka Coll, '57, prgmr
- Rollins, Larry L / Prgmg Anal, . . . / MP / '34, Wm Jewell Coll, '59, prgmg anal
- Shervem, Robert M / Chem Engr, . . . / AS, chem engr applns / '20, Univ of Wash, '58, chem engr
- Smith, Jr, Claude M / Compr Anal & Design Engr, . . . / ADP / '22, Ariz State Univ, '57, compr anal & design engr
- Snow, James L / Prgmg Anal, . . . / AP / '37, Auburn, '58, prgmg anal
- Spooner, C B / Num Anal, . . . / P / '29, Ariz State Univ, '56, num anal
- Stanton, Leroy K / Num Anal, . . . / AMP / '34, Univ of Colo, '57, num anal
- Till, Frank L / Prgmr, . . . / P / '22, ASU, '58, prgmr
- White, Hubert Dale / Mgr, Engrg Sys Applns, . . . / AMP / '30, U of Iowa, '55, engrg sys aplns
- Widenor, Robert D / Compr Anal, . . . / AP / '30, Calif Maritime Acad, '59, compr anal
- Zilliox, Royal Q / Num Anal, . . . / MP / '26, So Methodist U, '58, num anal
- U. S. Department of Health, Education, and Welfare, Public Health Service, Washington 25, D.C.
- Bromer, Louis / Chief, Statl & Reports Br, . . . / AM / '17, Geo Wash Univ, '56, statn
- Bryant, J. Howard / Research Psychologist, . . . / AP / '31, La. State Univ, '57, psychologist
- Evans, Jr, Stanley J / Staff Coordinator of EDP Plans, . . . / AB, aplns in fields of medl res & hospl admin / '25, Univ of Minn, '55, mngt analysis
- Garro, N. Edward / prgm analyst (trainee), . . . / AP / '25, H.S., '58, prgmg
- Joyce, George R / Digital Compr Prgmr, . . . / ALP / '26, American U, '58, prgmr
- Lieberman, Leslie G / Analytical Statn, . . . / AP / '27, Univ of Md, '57, statn
- Little, Robert T / Supervisory Statn, . . . / AP / '09, Miss Southern Coll, '56, electronic systems
- Livingstone, Evelyn C / Digital Compr Prgmr, . . . / P / '18, H.S., '59, prgmr
- Madigan, Eleanor L / Data Procg Specialist, . . . / P / '17, H.S., '57, data prog
- Meyer, Burton / Analytical Statn, . . . / A / '24, Syracuse Univ, '57, psychologist
- Rikli, Dr. Arthur E / Chf, Heart Disease Contr Progr, . . . / A / '17, Johns Hopkins, '55, physician
- Rothenbuhler, Ervin F / Mgm Analysis Ofcr, . . . / AB / '17, Bowling Green Univ, '58, mgm analysis
- Sartwell, Wilbur M / Digital Compr Prgmr, . . . / P / '21, American Univ, '57, digital compr prgmr
- Electronic Business Services, 3266 Hunts Point Rd., Bellevue, Wash.
- Galloway, Adelbert K / Engr, . . . / ABCDELMPS / '15, Metropolitan Bus Coll, '59, engr
- Lewis, Dorsey S / Owner, . . . / ABCDELMPS / '13, Univ of Wash, '47, EDPM Aplns Consultant



and at tech/ops' Monterey

Research Office, in California, equally interesting and challenging work developing computer applications for planning, feasibility testing, and real time control of operational and logistical problems (for the Navy and industry) . . .

Here, too, *tech/ops* needs scientists who habitually seek original thought patterns, and who respond to challenge.

The over-all Company policies in the areas of fringe benefits and profit-sharing plans are unique.

If challenge and reward appeal to you . . . write or wire collect:

**Harold E. Kren
Technical
Operations,
Incorporated**



305 WEBSTER STREET
MONTEREY, CALIFORNIA

NEW PATENTS

RAYMOND R. SKOLNICK

Reg. Patent Agent

Ford Inst. Co., Div. of Sperry Rand Corp.
Long Island City 1, New York

THE following is a compilation of patents pertaining to computers and associated equipment from the "Official Gazette of the United States Patent Office," dates of issue as indicated. Each entry consists of: patent number / inventor(s) / assignee / invention. Printed copies of patents may be obtained from the U.S. Commissioner of Patents, Washington 25, D.C., at a cost of 25 cents each.

May 5, 1959: 2,885,148 / Edgar A. Brown, Vestal, and Eugene A. Sands, Mount Kisco, N.Y. / Burroughs Corp., a corp. of Mich. / A multitude order binary accumulator.
2,885,149 / Genung L. Clapper, Vestal, N.Y. / International Business Machines Corp., New York, N.Y. / A transistor full adder.
2,885,662 / Siegfried Hansen, Los Angeles, Calif. / Litton Industries, Inc., Beverly Hills, Calif. / An analog-to-difunction converter.
2,885,663 / Daniel L. Curtis, Manhattan Beach, Calif. / Litton Industries, Inc., Beverly Hills, Calif. / An apparatus for analog-to-difunction conversion.
May 12, 1959: 2,886,241 / Spencer W. Spaulding, Wynnewood, and Ralph Pressman, Philadelphia, Pa. / R.C.A.,

a corp. of Del. / A code converter using a plurality of serially connected binary channels.
2,886,242 / Edward J. Petherick, Rowledge, near Farnham, and Geoffrey Charles Rowley, Sutton, Eng. / I.B.M. Corp., New York, N.Y. / An electrical digital parallel decimal accumulator.
2,886,243 / Richard E. Sprague, Redondo Beach, and Donald E. Eckdahl, Manhattan Beach, Calif. / Northrop Aircraft, Inc., Hawthorne, Calif. / An incremental slope function generator.
2,886,753 / Wilton R. Abbott, Los Gatos, Calif. / North American Aviation, Inc., California / A digital positioning servo.
May 19, 1959: 2,887,269 / Siegfried Reisch, Ivrea, Italy / Ing. C. Olivetti & C., S.p.A., Ivrea, Italy / An electric pulse counting and calculating apparatus.
2,887,270 / Rolf Edmund Spencer, West Ealing, London, Eng. / Electric and Musical Ind. Lim., Hayes, Middlesex, Eng. / An anlog computing apparatus to evaluate the rate of change of one variable with respect to another.
2,887,552 / Howard E. Lustig, Flushing, and William F. Weber, Huntington, N.Y. / Sperry Rand Corporation, Ford Inst. Co. Div., L.I.C., N.Y. / A punched card resistance matrix function generator.
2,887,653 / George H. Myers, Fanwood, N.J. / Bell Telephone Lab., Inc., New York, N.Y. / A time interval encoder.
2,887,674 / George B. Greene, Berkeley, Calif. / Marchant Research, Inc., a corp. of Calif. / A pulse width memory unit.
2,887,676 / Eugene P. Hamilton, Rich-

mond, Calif. / Marchant Research, Inc., a corp. of Calif. / A pulse interpreter.
May 26, 1959: 2,888,200 / Eric Weiss, Los Angeles, Calif. / National Cash Register Co., a corp. of Maryland / A computer circuit for generation of the square root of a binary number.
2,888,202 / John V. Blanenbaker, Albany, Oreg., and Robert Royce Johnson, Pasadena, Calif. / Hughes Aircraft Co., a corp. of Del. / A multiple input binary-adder-subtractor.
2,888,560 / Robert P. Talambiras, Cambridge, Mass. / Sperry Rand Corp., New York, N.Y. / A modulator binary counter circuit.
2,888,667 / William F. Schmitt, Wayne, Pa., Sperry Rand Corp., New York, N.Y. / A shifting register with passive intermediate storage.
June 2, 1959: 2,889,189 / Samuel G. Cohen, Ossining, N.Y. / General Precision Lab., Inc., a corp. of N.Y. / A digital-to-analog converter and plotter.
2,889,534 / Samuel Lubkin, Brooklyn, N.Y. / Underwood Corp., New York, N.Y. / A binary serial comparator.
2,889,539 / Robert J. Roth, Mount Pleasant, N.Y. / International Business Machines Corp., New York, N.Y. / A data storage device.
2,889,540 / Edwin W. Bauer and Munroe K. Haynes, Poughkeepsie, N.Y. / International Business Machines Corp., New York, N.Y. / A magnetic memory system with disturbance cancellation.
2,889,542 / Ronald B. Goldner, Cambridge, Mass. and Jerome J. Suran, Syracuse, N.Y. / General Electric Co., a corp. of N.Y. / A magnetic coincidence gating register.

ADVERTISING INDEX

Following is the index of advertisements. Each item contains: Name and address of the advertiser / page number where the advertisement appears / name of agency if any.

- Bell Aircraft Corp., Buffalo, N.Y. / Page 30 / The Rumrill Co., Inc.
Bendix Aviation Corp., Computer Div., 5630 Arbor Vitae St., Los Angeles, Calif. / Page 2 / Shaw Advertising Inc.
Bendix Aviation Corp., Eclipse-Pioneer Div., Route 46 at 17, Teterboro, N.J. / Page 35 / Deutsch & Shea, Inc.
Berkeley Enterprises, Inc., 815 Washington St., Newtonville 60, Mass. / Page 23 / —
C. P. Clare & Co., 3101 Pratt Blvd., Chicago 45, Ill. / Page 27 / Reincke, Meyer, and Finn
Computer Systems, Inc., 611 Broadway, New York 12, N.Y. / Page 7 / Smith, Winters, Mabuchi, Inc.
Computers and Automation, 815 Washington St., Newtonville 60, Mass. / Page 31 / —
Hughes Aircraft Co., Fullerton Research and Development, Fullerton, Orange County, So. California / Page 28 / Foote, Cone & Belding
Hughes Products, Industrial Systems Div., International Airport Station, Los Angeles 45, Calif. / Page 17 / Foote, Cone & Belding
The Mitre Corp., 244 Wood St., Lexington 73, Mass. / Page 19 / Deutsch & Shea, Inc.
National Cash Register Co., Dayton 9, Ohio / Page 36 / McCann-Erickson, Inc.
Norden Div., United Aircraft Corp., Data Systems Dept., 13210 Crenshaw Blvd., Gardena, Calif. / Page 26 / Clyde D. Graham, Advertising
Philco Corp., Government & Industrial Div., 4700 Wisahickon Ave., Philadelphia 44, Pa. / Page 3 / Maxwell Associates, Inc.
Republic Aviation, Farmingdale, L.I., N.Y. / Page 21 / Deutsch & Shea, Inc.
Royal McBee Corp., Data Processing Div., Port Chester, N.Y. / Page 8 / C. J. LaRoche & Co.
Sandia Corp., Sandia Base, Albuquerque, N.M. / Page 22 / Ward Hicks Advertising
System Development Corp., 2406 Colorado Ave., Santa Monica, Calif. / Page 5 / Stromberger, LaVene, McKenzie
Technical Operations, Inc., 3520 Prospect St., N.W., Washington 7, D.C. / Page 32 / Dawson MacLeod & Stivers
Technical Operations, Inc., 305 Webster St., Monterey, Calif. / Page 33 / Dawson MacLeod & Stivers
Texas Instruments Incorporated, Box 1079, Dallas Tex. / Pages 24, 25 / Don L. Baxter, Inc.

COMPUTER ENGINEERS

Bendix Aviation Corporation's Eclipse-Pioneer Division

Invites You
to Participate in a Newly-Expanded Program in

TRANSISTORIZED AIRBORNE DIGITAL COMPUTING SYSTEMS

The expansion of our Advanced Research and Development program in solid state airborne digital computation and control has created a number of outstanding opportunities for qualified computer engineers. If you are interested in working on new digital concepts with a leader in the airborne computing and control system fields, and if you are currently qualified in one of the following areas...

Digital Systems Synthesis
Logical Design
High Speed Switching
Logical Implementations
Magnetic Memory

Input-Output Devices
Transistorized Circuitry
Pulse Techniques
Miniaturization
Micro-Miniaturization

... we suggest that you send a brief resume of your experience and educational background to Dr. Arthur S. Robinson, or telephone Engineering Personnel at ATlas 8-2000 in New Jersey, or BRyant 9-8541 in New York.

ECLIPSE-PIONEER DIVISION

The Bendix logo is a stylized, italicized script font with a horizontal line through the middle of the letters.

AVIATION CORPORATION

Route 46 at 17, Teterboro, New Jersey

(Located in suburban New Jersey, 10 minutes from New York City)

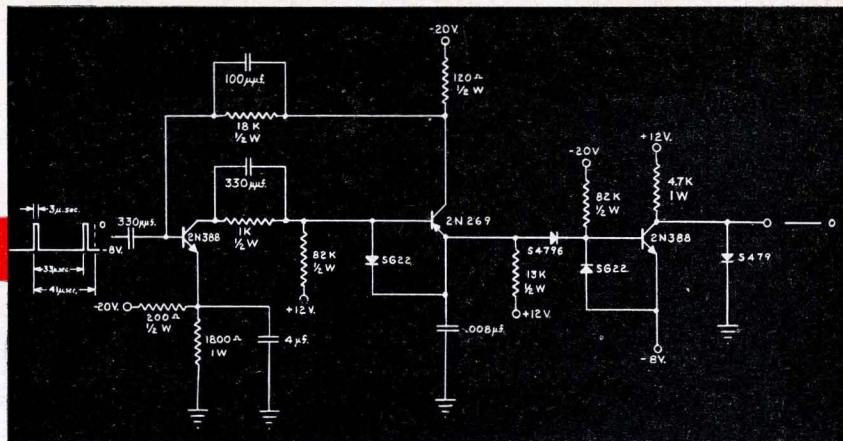

ELECTRONIC ENGINEERS . . . PHYSICISTS . . . CHEMISTS:
NATIONAL OFFERS
CHALLENGING OPPORTUNITIES
IN YOUR FIELD

The National Cash Register Company—a leader in the application of automation to business machines—has organized its Research and Development Division to provide ideal working environments for technically trained men and women of the highest calibre. Proj-

ects in progress are of an exciting, stimulating nature . . . for instance, considerable work is being done on Encapsulation and thin film memory and switching components. Your training and experience may qualify you for a position in one of these areas:

**DATA
PROCESSING
RESEARCH AND
DEVELOPMENT**

Computer Theory
 Computer Component
 Development
 Machine Organization
 Studies
 High-Speed
 Non-Mechanical Printing
 and Multi-Copy Methods
 Direct Character
 Recognition
 Systems Design

**ELECTRONIC
ENGINEERING
DEVELOPMENT**

High-Speed Switching
 Circuit Techniques
 Random Access Memory
 Systems
 Circuit and Logical
 Design
 Advanced Storage
 Concepts Utilizing
 Electron Beams
 Microminiaturization
 of Components and
 Circuitry

**SOLID STATE
PHYSICS**

Electrodeposited
 Magnetic Films
 Vacuum Deposited Thin
 Magnetic Films
 Ferrites and
 Ferromagnetics
 Electroluminescence-
 Photoconductor
 Investigations
 Advanced Magnetic
 Tape Studies

CHEMISTRY

Plastics and Polymers
 Encapsulation
 (A process for producing
 microscopic capsules
 containing liquids or
 reactive solids)
 Photochromic Materials
 (Studies of National-
 developed compounds
 which are photosensitive
 to specific wave lengths
 of light, for application
 to memory, printing and
 photocopy devices)
 Magnetic Coatings

NATIONAL'S NEW RESEARCH AND DEVELOPMENT Center is located in Dayton, Ohio, one of the midwest's most progressive cities.

FOR COMPLETE INFORMATION, simply send your resume to Mr. T. F. Wade, Technical Placement, F-3, The National Cash Register Company, Dayton 9, Ohio. All correspondence will be kept strictly confidential.

THE NATIONAL CASH REGISTER COMPANY, Dayton 9, Ohio

ONE OF THE WORLD'S MOST SUCCESSFUL CORPORATIONS

1039 OFFICES IN 121 COUNTRIES • 75 YEARS OF HELPING BUSINESS SAVE MONEY

*TRADEMARK REG. U. S. PAT. OFF.

*National**

VERSATILE DATA PROCESSING
 ADDING MACHINES • CASH REGISTERS
 ACCOUNTING MACHINES • NCR PAPER
 DIVERSIFIED CHEMICAL PRODUCTS